

Exhibit_A Pricing Page

CRFQ 0803 DOT1800000097

60,000 GVWR Truck with 23-Ton Crane

Item No.	Description:	Make/Model & Year	Estimated Unit Quantity	Unit Price	Item Total Cost
1	Complete Unit: 60,000 GVWR Truck w/ 23-Ton Crane	Make: International Model: HV507 Year: 2019	15	\$ 335,760.56 -	\$5,036,408.40 -
Total Bid Cost					\$ 5,036,408.40 -

Bid will be awarded to the lowest overall bid total.

Vendor: Worldwide Equipment

Contact Name: Matt Cochran

Email: matt.cochran@thetruckpeople.com

RECEIVED
2018 JUN 14 AM 11:18
WV PURCHASING
DIVISION



JOHN A. MYERS
CABINET SECRETARY

STATE OF WEST VIRGINIA
DEPARTMENT OF ADMINISTRATION
PURCHASING DIVISION
2019 WASHINGTON STREET, EAST
CHARLESTON, WEST VIRGINIA 25305-0130

W. MICHAEL SHEETS
DIRECTOR

State of West Virginia Bid Opportunity

Solicitation Type	CRFQ
Solicitation No.	DOT1800000097
Description:	60,000 GVWR Tandem Axle Truck W/ 23-Ton Crane
Deadline for Q&A:	05/22/18
Mandatory Bid Conference:	05/17/18 10:00 AM EST
Bid Closing Date and Time:	05/31/18 1:30 PM EST

Dear Potential Bidder:

Your business has been identified as a potential vendor by the requesting agency for the solicitation noted above.

Should your business be interested in this bid opportunity, please visit www.wvOASIS.gov, and click on the Vendor Self Service (VSS) Portal. At the welcome screen, please review any announcements and log into your account or click on the "Public Access" button in the bottom left of the page in order to view the *West Virginia Purchasing Bulletin*. At the *West Virginia Purchasing Bulletin* page, you may view all bid opportunities or you may search for the solicitation noted above by typing the solicitation number in the "keyword search" box. All modifications to solicitations prior to award will be noted as an "addendum" and also available at this same location.

The *West Virginia Purchasing Bulletin* lists all bid opportunities more than \$5,000 for the state of West Virginia. Solicitations prefaced with an "A" are agency-delegated bid opportunities expected to be \$25,000 or less; those prefaced with an "C" are central Purchasing Division solicitations expected to exceed \$25,000.

Additional information may be accessed by clicking on the summary or details of the solicitation.

Should you decide to bid on this opportunity, you may submit a bid through the acceptable delivery methods including electronic submission via *wvOASIS* system, hand delivery, delivery by courier, or by facsimile; however, the Purchasing Division cannot accept bids via electronic mail.

Thank you for your interest in doing business with the State of West Virginia. Should you have any questions regarding becoming a registered vendor with the Purchasing Division, please visit our vendor registration webpage at <http://www.state.wv.us/admin/purchase/VendorReg.html>.

West Virginia Purchasing Division
WVPurchasing.gov



Purchasing Division
 2019 Washington Street East
 Post Office Box 50130
 Charleston, WV 25305-0130

State of West Virginia
 Request for Quotation
 13 - Equipment

Proc Folder: 445837

Doc Description: (Class 332) 60,000 GVWR TANDEM AXLE TRUCK W/ 23-TON CRANE

Proc Type: Central Master Agreement

Date Issued	Solicitation Closes	Solicitation No	Version
2018-05-04	2018-05-31 13:30:00	CRFQ 0803 DOT1800000097	1

BID RECEIVING LOCATION

BID CLERK
 DEPARTMENT OF ADMINISTRATION
 PURCHASING DIVISION
 2019 WASHINGTON ST E
 CHARLESTON WV 25305
 US

VENDOR

Vendor Name, Address and Telephone Number:

Worldwide Equipment
 408 New Goff Mountain Rd
 Cross Lanes, WV 25313
 304-345-2490

FOR INFORMATION CONTACT THE BUYER

Mark A Atkins
 (304) 558-2307
 mark.a.atkins@wv.gov

Signature X

FEIN # 45-1024981

DATE

6-14-18

All offers subject to all terms and conditions contained in this solicitation

ADDITIONAL INFORMATION:

The West Virginia Purchasing Division is soliciting bids on behalf of the West Virginia Division of Highways, Department of Transportation to establish an open-end contract for a 60,000 GVWR Tandem Axle Straight Truck with 23-ton behind cab Crane with Outriggers per attached documents.

MANDATORY PRE-BID MEETING:

WV Division of Highways
 Equipment Division
 83 Brushy Fork Rd Crossing
 Buckhannon, WV 26201

Time: 10:00am EDT
 Date: May 17, 2018

INVOICE TO	SHIP TO
DIVISION OF HIGHWAYS EQUIPMENT DIVISION RT 33 83 BRUSHY ROAD CROSSING, PO BOX 610 BUCKHANNON WV26201 US	DIVISION OF HIGHWAYS EQUIPMENT DIVISION 83 BRUSHY FORK RD CROSSING BUCKHANNON WV 26201 US

Line	Comm Ln Desc	Qty	Unit Issue	Unit Price	Total Price
1	60,000 GVWR TRUCK WITH 23-TON TRUCK CRANE	15.00000	EA		

Comm Code	Manufacturer	Specification	Model #
25101933			

Extended Description :

60,000 GVWR TRUCK WITH 23-TON TRUCK CRANE:

Year:

Make:

Model:

SCHEDULE OF EVENTS

Line	Event	Event Date
1	Mandatory PreBid Meeting @ 10:00am EDT:	2018-05-17
2	Technical Questions due by 2:00pm EDT:	2018-05-22

DOT1800000097	Document Phase Final	Document Description (Class 332) 60,000 GVWR TANDEM AXLE TRUCK W/ 23-TON CRANE	Page 3 of 3
----------------------	--------------------------------	---	------------------------------

ADDITIONAL TERMS AND CONDITIONS

See attached document(s) for additional Terms and Conditions

INSTRUCTIONS TO VENDORS SUBMITTING BIDS

1. REVIEW DOCUMENTS THOROUGHLY: The attached documents contain a solicitation for bids. Please read these instructions and all documents attached in their entirety. These instructions provide critical information about requirements that if overlooked could lead to disqualification of a Vendor's bid. All bids must be submitted in accordance with the provisions contained in these instructions and the Solicitation. Failure to do so may result in disqualification of Vendor's bid.

2. MANDATORY TERMS: The Solicitation may contain mandatory provisions identified by the use of the words "must," "will," and "shall." Failure to comply with a mandatory term in the Solicitation will result in bid disqualification.

3. PREBID MEETING: The item identified below shall apply to this Solicitation.

A pre-bid meeting will not be held prior to bid opening

A **NON-MANDATORY PRE-BID** meeting will be held at the following place and time:

A **MANDATORY PRE-BID** meeting will be held at the following place and time:

WV Division of Highways
Equipment Division
83 Brushy Fork Rd Crossing
Buckhannon, WV 26201

Time: 10:00am EDT

Date: May 17, 2018

All Vendors submitting a bid must attend the mandatory pre-bid meeting. Failure to attend the mandatory pre-bid meeting shall result in disqualification of the Vendor's bid. No one person attending the pre-bid meeting may represent more than one Vendor.

An attendance sheet provided at the pre-bid meeting shall serve as the official document verifying attendance. The State will not accept any other form of proof or documentation to verify attendance. Any person attending the pre-bid meeting on behalf of a Vendor must list on the attendance sheet his or her name and the name of the Vendor he or she is representing.

Additionally, the person attending the pre-bid meeting should include the Vendor's E-Mail address, phone number, and Fax number on the attendance sheet. It is the Vendor's responsibility to locate the attendance sheet and provide the required information. Failure to complete the attendance sheet as required may result in disqualification of Vendor's bid.

All Vendors should arrive prior to the starting time for the pre-bid. Vendors who arrive after the starting time but prior to the end of the pre-bid will be permitted to sign in, but are charged with knowing all matters discussed at the pre-bid.

Questions submitted at least five business days prior to a scheduled pre-bid will be discussed at the pre-bid meeting if possible. Any discussions or answers to questions at the pre-bid meeting are preliminary in nature and are non-binding. Official and binding answers to questions will be published in a written addendum to the Solicitation prior to bid opening.

4. VENDOR QUESTION DEADLINE: Vendors may submit questions relating to this Solicitation to the Purchasing Division. Questions must be submitted in writing. All questions must be submitted on or before the date listed below and to the address listed below in order to be considered. A written response will be published in a Solicitation addendum if a response is possible and appropriate. Non-written discussions, conversations, or questions and answers regarding this Solicitation are preliminary in nature and are nonbinding.

Submitted e-mails should have solicitation number in the subject line.

Question Submission Deadline: May 22, 2018 due by 2:00pm EDT

Submit Questions to: Mark Atkins, Senior Buyer
2019 Washington Street, East
Charleston, WV 25305
Fax: (304) 558-4115 (Vendors should not use this fax number for bid submission)
Email: Mark.A.Atkins@wv.gov

5. VERBAL COMMUNICATION: Any verbal communication between the Vendor and any State personnel is not binding, including verbal communication at the mandatory pre-bid conference. Only information issued in writing and added to the Solicitation by an official written addendum by the Purchasing Division is binding.

6. BID SUBMISSION: All bids must be submitted electronically through wvOASIS or signed and delivered by the Vendor to the Purchasing Division at the address listed below on or before the date and time of the bid opening. Any bid received by the Purchasing Division staff is considered to be in the possession of the Purchasing Division and will not be returned for any reason. The Purchasing Division will not accept bids, modification of bids, or addendum acknowledgment forms via e-mail. Acceptable delivery methods include electronic submission via wvOASIS, hand delivery, delivery by courier, or facsimile.

The bid delivery address is:
Department of Administration, Purchasing Division
2019 Washington Street East
Charleston, WV 25305-0130

A bid that is not submitted electronically through wvOASIS should contain the information listed below on the face of the envelope or the bid may be rejected by the Purchasing Division.:

SEALED BID: Truck with Crane
BUYER: Mark Atkins, File#33
SOLICITATION NO.: CRFQ 0803 DOT1800000097
BID OPENING DATE: 05/31/2018
BID OPENING TIME: 1:30pm EDT
FAX NUMBER: 304-558-3970

The Purchasing Division may prohibit the submission of bids electronically through wvOASIS at its sole discretion. Such a prohibition will be contained and communicated in the wvOASIS system resulting in the Vendor's inability to submit bids through wvOASIS. Submission of a response to an Expression or Interest or Request for Proposal is not permitted in wvOASIS.

For Request For Proposal ("RFP") Responses Only: In the event that Vendor is responding to a request for proposal, the Vendor shall submit one original technical and one original cost proposal plus N/A convenience copies of each to the Purchasing Division at the address shown above. Additionally, the Vendor should identify the bid type as either a technical or cost proposal on the face of each bid envelope submitted in response to a request for proposal as follows:

BID TYPE: (This only applies to CRFP)

- Technical
 Cost

7. BID OPENING: Bids submitted in response to this Solicitation will be opened at the location identified below on the date and time listed below. Delivery of a bid after the bid opening date and time will result in bid disqualification. For purposes of this Solicitation, a bid is considered delivered when confirmation of delivery is provided by wvOASIS (in the case of electronic submission) or when the bid is time stamped by the official Purchasing Division time clock (in the case of hand delivery).

Bid Opening Date and Time: May 31, 2018 at 1:30pm EDT

Bid Opening Location: Department of Administration, Purchasing Division
2019 Washington Street East
Charleston, WV 25305-0130

8. ADDENDUM ACKNOWLEDGEMENT: Changes or revisions to this Solicitation will be made by an official written addendum issued by the Purchasing Division. Vendor should acknowledge receipt of all addenda issued with this Solicitation by completing an Addendum Acknowledgment Form, a copy of which is included herewith. Failure to acknowledge addenda may result in bid disqualification. The addendum acknowledgement should be submitted with the bid to expedite document processing.

9. BID FORMATTING: Vendor should type or electronically enter the information onto its bid to prevent errors in the evaluation. Failure to type or electronically enter the information may result in bid disqualification.

10. ALTERNATES: Any model, brand, or specification listed in this Solicitation establishes the acceptable level of quality only and is not intended to reflect a preference for, or in any way favor, a particular brand or vendor. Vendors may bid alternates to a listed model or brand provided that the alternate is at least equal to the model or brand and complies with the required specifications. The equality of any alternate being bid shall be determined by the State at its sole discretion. Any Vendor bidding an alternate model or brand should clearly identify the alternate items in its bid and should include manufacturer's specifications, industry literature, and/or any other relevant documentation demonstrating the equality of the alternate items. Failure to provide information for alternate items may be grounds for rejection of a Vendor's bid.

11. EXCEPTIONS AND CLARIFICATIONS: The Solicitation contains the specifications that shall form the basis of a contractual agreement. Vendor shall clearly mark any exceptions, clarifications, or other proposed modifications in its bid. Exceptions to, clarifications of, or modifications of a requirement or term and condition of the Solicitation may result in bid disqualification.

12. COMMUNICATION LIMITATIONS: In accordance with West Virginia Code of State Rules §148-1-6.6, communication with the State of West Virginia or any of its employees regarding this Solicitation during the solicitation, bid, evaluation or award periods, except through the Purchasing Division, is strictly prohibited without prior Purchasing Division approval. Purchasing Division approval for such communication is implied for all agency delegated and exempt purchases.

13. REGISTRATION: Prior to Contract award, the apparent successful Vendor must be properly registered with the West Virginia Purchasing Division and must have paid the \$125 fee, if applicable.

14. UNIT PRICE: Unit prices shall prevail in cases of a discrepancy in the Vendor's bid.

15. PREFERENCE: Vendor Preference may only be granted upon written request and only in accordance with the West Virginia Code § 5A-3-37 and the West Virginia Code of State Rules. A Vendor Preference Certificate form has been attached hereto to allow Vendor to apply for the preference. Vendor's failure to submit the Vendor Preference Certificate form with its bid will result in denial of Vendor Preference. Vendor Preference does not apply to construction projects.

16. SMALL, WOMEN-OWNED, OR MINORITY-OWNED BUSINESSES: For any solicitations publicly advertised for bid, in accordance with West Virginia Code §5A-3-37(a)(7) and W. Va. CSR § 148-22-9, any non-resident vendor certified as a small, women-owned, or minority-owned business under W. Va. CSR § 148-22-9 shall be provided the same preference made available to any resident vendor. Any non-resident small, women-owned, or minority-owned business must identify itself as such in writing, must submit that writing to the Purchasing Division with its bid, and must be properly certified under W. Va. CSR § 148-22-9 prior to contract award to receive the preferences made available to resident vendors. Preference for a non-resident small, women-owned, or minority owned business shall be applied in accordance with W. Va. CSR § 148-22-9.

17. WAIVER OF MINOR IRREGULARITIES: The Director reserves the right to waive minor irregularities in bids or specifications in accordance with West Virginia Code of State Rules § 148-1-4.6.

18. ELECTRONIC FILE ACCESS RESTRICTIONS: Vendor must ensure that its submission in wvOASIS can be accessed and viewed by the Purchasing Division staff immediately upon bid opening. The Purchasing Division will consider any file that cannot be immediately accessed and viewed at the time of the bid opening (such as, encrypted files, password protected files, or incompatible files) to be blank or incomplete as context requires, and are therefore unacceptable. A vendor will not be permitted to unencrypt files, remove password protections, or resubmit documents after bid opening to make a file viewable if those documents are required with the bid. A Vendor may be required to provide document passwords or remove access restrictions to allow the Purchasing Division to print or electronically save documents provided that those documents are viewable by the Purchasing Division prior to obtaining the password or removing the access restriction.

19. NON-RESPONSIBLE: The Purchasing Division Director reserves the right to reject the bid of any vendor as Non-Responsible in accordance with W. Va. Code of State Rules § 148-1-5.3, when the Director determines that the vendor submitting the bid does not have the capability to fully perform, or lacks the integrity and reliability to assure good-faith performance.”

20. ACCEPTANCE/REJECTION: The State may accept or reject any bid in whole, or in part in accordance with W. Va. Code of State Rules § 148-1-4.5. and § 148-1-6.4.b.”

21. YOUR SUBMISSION IS A PUBLIC DOCUMENT: Vendor’s entire response to the Solicitation and the resulting Contract are public documents. As public documents, they will be disclosed to the public following the bid/proposal opening or award of the contract, as required by the competitive bidding laws of West Virginia Code §§ 5A-3-1 et seq., 5-22-1 et seq., and 5G-1-1 et seq. and the Freedom of Information Act West Virginia Code §§ 29B-1-1 et seq.

DO NOT SUBMIT MATERIAL YOU CONSIDER TO BE CONFIDENTIAL, A TRADE SECRET, OR OTHERWISE NOT SUBJECT TO PUBLIC DISCLOSURE.

Submission of any bid, proposal, or other document to the Purchasing Division constitutes your explicit consent to the subsequent public disclosure of the bid, proposal, or document. The Purchasing Division will disclose any document labeled “confidential,” “proprietary,” “trade secret,” “private,” or labeled with any other claim against public disclosure of the documents, to include any “trade secrets” as defined by West Virginia Code § 47-22-1 et seq. All submissions are subject to public disclosure without notice.

22. INTERESTED PARTY DISCLOSURE: W. Va. Code § 6D-1-2 requires that for contracts with an actual or estimated value of at least \$100,000, the vendor must submit to the Purchasing Division a disclosure of interested parties to the contract, prior to contract award. That disclosure must occur on the form prescribed and approved by the WV Ethics Commission. A copy of that form is included with this solicitation or can be obtained from the WV Ethics Commission. "Interested parties" means: (1) A business entity performing work or service pursuant to, or in furtherance of, the applicable contract, including specifically sub-contractors; (2) the person(s) who have an ownership interest equal to or greater than 25% in the business entity performing work or service pursuant to, or in furtherance of, the applicable contract; and (3) the person or business entity, if any, that served as a compensated broker or intermediary to actively facilitate the applicable contract or negotiated the terms of the applicable contract with the state agency: Provided, That subdivision (2) shall be inapplicable if a business entity is a publicly traded company: Provided, however, That subdivision (3) shall not include persons or business entities performing legal services related to the negotiation or drafting of the applicable contract.

23. WITH THE BID REQUIREMENTS: In instances where these specifications require documentation or other information with the bid, and a vendor fails to provide it with the bid, the Director of the Purchasing Division reserves the right to request those items after bid opening and prior to contract award pursuant to the authority to waive minor irregularities in bids or specifications under W. Va. CSR § 148-1-4.6. This authority does not apply to instances where state law mandates receipt with the bid.

GENERAL TERMS AND CONDITIONS:

1. CONTRACTUAL AGREEMENT: Issuance of a Award Document signed by the Purchasing Division Director, or his designee, and approved as to form by the Attorney General's office constitutes acceptance of this Contract made by and between the State of West Virginia and the Vendor. Vendor's signature on its bid signifies Vendor's agreement to be bound by and accept the terms and conditions contained in this Contract.

2. DEFINITIONS: As used in this Solicitation/Contract, the following terms shall have the meanings attributed to them below. Additional definitions may be found in the specifications included with this Solicitation/Contract.

2.1. "Agency" or "Agencies" means the agency, board, commission, or other entity of the State of West Virginia that is identified on the first page of the Solicitation or any other public entity seeking to procure goods or services under this Contract.

2.2. "Bid" or "Proposal" means the vendors submitted response to this solicitation.

2.3. "Contract" means the binding agreement that is entered into between the State and the Vendor to provide the goods or services requested in the Solicitation.

2.4. "Director" means the Director of the West Virginia Department of Administration, Purchasing Division.

2.5. "Purchasing Division" means the West Virginia Department of Administration, Purchasing Division.

2.6. "Award Document" means the document signed by the Agency and the Purchasing Division, and approved as to form by the Attorney General, that identifies the Vendor as the contract holder.

2.7. "Solicitation" means the official notice of an opportunity to supply the State with goods or services that is published by the Purchasing Division.

2.8. "State" means the State of West Virginia and/or any of its agencies, commissions, boards, etc. as context requires.

2.9. "Vendor" or "Vendors" means any entity submitting a bid in response to the Solicitation, the entity that has been selected as the lowest responsible bidder, or the entity that has been awarded the Contract as context requires.

3. CONTRACT TERM; RENEWAL; EXTENSION: The term of this Contract shall be determined in accordance with the category that has been identified as applicable to this Contract below:

Term Contract

Initial Contract Term: **Initial Contract Term:** This Contract becomes effective on _____ upon award _____ and extends for a period of One year(s).

Renewal Term: This Contract may be renewed upon the mutual written consent of the Agency, and the Vendor, with approval of the Purchasing Division and the Attorney General's office (Attorney General approval is as to form only). Any request for renewal should be delivered to the Agency and then submitted to the Purchasing Division thirty (30) days prior to the expiration date of the initial contract term or appropriate renewal term. A Contract renewal shall be in accordance with the terms and conditions of the original contract. Unless otherwise specified below, renewal of this Contract is limited to (3) three successive one (1) year periods or multiple renewal periods of less than one year, provided that the multiple renewal periods do not exceed the total number of months available in all renewal years combined. Automatic renewal of this Contract is prohibited. Renewals must be approved by the Vendor, Agency, Purchasing Division and Attorney General's office (Attorney General approval is as to form only)

Alternate Renewal Term – This contract may be renewed for _____ successive _____ year periods or shorter periods provided that they do not exceed the total number of months contained in all available renewals. Automatic renewal of this Contract is prohibited. Renewals must be approved by the Vendor, Agency, Purchasing Division and Attorney General's office (Attorney General approval is as to form only)

Delivery Order Limitations: In the event that this contract permits delivery orders, a delivery order may only be issued during the time this Contract is in effect. Any delivery order issued within one year of the expiration of this Contract shall be effective for one year from the date the delivery order is issued. No delivery order may be extended beyond one year after this Contract has expired.

Fixed Period Contract: This Contract becomes effective upon Vendor's receipt of the notice to proceed and must be completed within _____ days.

Fixed Period Contract with Renewals: This Contract becomes effective upon Vendor's receipt of the notice to proceed and part of the Contract more fully described in the attached specifications must be completed within _____ days. Upon completion of the work covered by the preceding sentence, the vendor agrees that maintenance, monitoring, or warranty services will be provided for _____ year(s) thereafter.

One Time Purchase: The term of this Contract shall run from the issuance of the Award Document until all of the goods contracted for have been delivered, but in no event will this Contract extend for more than one fiscal year.

Other: See attached.

4. NOTICE TO PROCEED: Vendor shall begin performance of this Contract immediately upon receiving notice to proceed unless otherwise instructed by the Agency. Unless otherwise specified, the fully executed Award Document will be considered notice to proceed.

5. QUANTITIES: The quantities required under this Contract shall be determined in accordance with the category that has been identified as applicable to this Contract below.

Open End Contract: Quantities listed in this Solicitation are approximations only, based on estimates supplied by the Agency. It is understood and agreed that the Contract shall cover the quantities actually ordered for delivery during the term of the Contract, whether more or less than the quantities shown.

Service: The scope of the service to be provided will be more clearly defined in the specifications included herewith.

Combined Service and Goods: The scope of the service and deliverable goods to be provided will be more clearly defined in the specifications included herewith.

One Time Purchase: This Contract is for the purchase of a set quantity of goods that are identified in the specifications included herewith. Once those items have been delivered, no additional goods may be procured under this Contract without an appropriate change order approved by the Vendor, Agency, Purchasing Division, and Attorney General's office.

6. EMERGENCY PURCHASES: The Purchasing Division Director may authorize the Agency to purchase goods or services in the open market that Vendor would otherwise provide under this Contract if those goods or services are for immediate or expedited delivery in an emergency. Emergencies shall include, but are not limited to, delays in transportation or an unanticipated increase in the volume of work. An emergency purchase in the open market, approved by the Purchasing Division Director, shall not constitute a breach of this Contract and shall not entitle the Vendor to any form of compensation or damages. This provision does not excuse the State from fulfilling its obligations under a One Time Purchase contract.

7. REQUIRED DOCUMENTS: All of the items checked below must be provided to the Purchasing Division by the Vendor as specified below.

BID BOND (Construction Only): Pursuant to the requirements contained in W. Va. Code § 5-22-1(c), All Vendors submitting a bid on a construction project shall furnish a valid bid bond in the amount of five percent (5%) of the total amount of the bid protecting the State of West Virginia. The bid bond must be submitted with the bid.

PERFORMANCE BOND: The apparent successful Vendor shall provide a performance bond in the amount of _____. The performance bond must be received by the Purchasing Division prior to Contract award. On construction contracts, the performance bond must be 100% of the Contract value.

LABOR/MATERIAL PAYMENT BOND: The apparent successful Vendor shall provide a labor/material payment bond in the amount of 100% of the Contract value. The labor/material payment bond must be delivered to the Purchasing Division prior to Contract award.

In lieu of the Bid Bond, Performance Bond, and Labor/Material Payment Bond, the Vendor may provide certified checks, cashier's checks, or irrevocable letters of credit. Any certified check, cashier's check, or irrevocable letter of credit provided in lieu of a bond must be of the same amount and delivered on the same schedule as the bond it replaces. A letter of credit submitted in lieu of a performance and labor/material payment bond will only be allowed for projects under \$100,000. Personal or business checks are not acceptable. Notwithstanding the foregoing, West Virginia Code § 5-22-1 (d) mandates that a vendor provide a performance and labor/material payment bond for construction projects. Accordingly, substitutions for the performance and labor/material payment bonds for construction projects is not permitted.

MAINTENANCE BOND: The apparent successful Vendor shall provide a two (2) year maintenance bond covering the roofing system. The maintenance bond must be issued and delivered to the Purchasing Division prior to Contract award.

LICENSE(S) / CERTIFICATIONS / PERMITS: In addition to anything required under the Section entitled Licensing, of the General Terms and Conditions, the apparent successful Vendor shall furnish proof of the following licenses, certifications, and/or permits prior to Contract award, in a form acceptable to the Purchasing Division.

The apparent successful Vendor shall also furnish proof of any additional licenses or certifications contained in the specifications prior to Contract award regardless of whether or not that requirement is listed above.

8. INSURANCE: The apparent successful Vendor shall furnish proof of the insurance identified by a checkmark below prior to Contract award. Subsequent to contract award, and prior to the insurance expiration date, Vendor shall provide the Agency with proof that the insurance mandated herein has been continued. Vendor must also provide Agency with immediate notice of any changes in its insurance policies mandated herein, including but not limited to, policy cancelation, policy reduction, or change in insurers. The insurance coverages identified below must be maintained throughout the life of this contract. The apparent successful Vendor shall also furnish proof of any additional insurance requirements contained in the specifications prior to Contract award regardless of whether or not that insurance requirement is listed in this section.

Vendor must maintain:

Commercial General Liability Insurance in at least an amount of:

1,000,000.00

State of WV must be listed as Certificate Holder on Insurance

Automobile Liability Insurance in at least an amount of: _____

Professional/Malpractice/Errors and Omission Insurance in at least an amount of:

Commercial Crime and Third Party Fidelity Insurance in an amount of:

Cyber Liability Insurance in an amount of: _____

Builders Risk Insurance in an amount equal to 100% of the amount of the Contract.

9. WORKERS' COMPENSATION INSURANCE: The apparent successful Vendor shall comply with laws relating to workers compensation, shall maintain workers' compensation insurance when required, and shall furnish proof of workers' compensation insurance upon request.

10. [Reserved]

11. LIQUIDATED DAMAGES: This clause shall in no way be considered exclusive and shall not limit the State or Agency's right to pursue any other available remedy. Vendor shall pay liquidated damages in the amount specified below or as described in the specifications:

_____ for _____

Liquidated Damages Contained in the Specifications

12. ACCEPTANCE: Vendor's signature on its bid, or on the certification and signature page, constitutes an offer to the State that cannot be unilaterally withdrawn, signifies that the product or service proposed by vendor meets the mandatory requirements contained in the Solicitation for that product or service, unless otherwise indicated, and signifies acceptance of the terms and conditions contained in the Solicitation unless otherwise indicated.

13. PRICING: The pricing set forth herein is firm for the life of the Contract, unless specified elsewhere within this Solicitation/Contract by the State. A Vendor's inclusion of price adjustment provisions in its bid, without an express authorization from the State in the Solicitation to do so, may result in bid disqualification.

14. PAYMENT: Payment in advance is prohibited under this Contract. Payment may only be made after the delivery and acceptance of goods or services. The Vendor shall submit invoices, in arrears.

15. PURCHASING CARD ACCEPTANCE: The State of West Virginia currently utilizes a Purchasing Card program, administered under contract by a banking institution, to process payment for goods and services. The Vendor must accept the State of West Virginia's Purchasing Card for payment of all orders under this Contract unless the box below is checked.

Vendor is not required to accept the State of West Virginia's Purchasing Card as payment for all goods and services.

16. TAXES: The Vendor shall pay any applicable sales, use, personal property or any other taxes arising out of this Contract and the transactions contemplated thereby. The State of West Virginia is exempt from federal and state taxes and will not pay or reimburse such taxes.

17. ADDITIONAL FEES: Vendor is not permitted to charge additional fees or assess additional charges that were not either expressly provided for in the solicitation published by the State of West Virginia or included in the unit price or lump sum bid amount that Vendor is required by the solicitation to provide. Including such fees or charges as notes to the solicitation may result in rejection of vendor's bid. Requesting such fees or charges be paid after the contract has been awarded may result in cancellation of the contract.

18. FUNDING: This Contract shall continue for the term stated herein, contingent upon funds being appropriated by the Legislature or otherwise being made available. In the event funds are not appropriated or otherwise made available, this Contract becomes void and of no effect beginning on July 1 of the fiscal year for which funding has not been appropriated or otherwise made available.

19. CANCELLATION: The Purchasing Division Director reserves the right to cancel this Contract immediately upon written notice to the vendor if the materials or workmanship supplied do not conform to the specifications contained in the Contract. The Purchasing Division Director may also cancel any purchase or Contract upon 30 days written notice to the Vendor in accordance with West Virginia Code of State Rules § 148-1-5.2.b.

20. TIME: Time is of the essence with regard to all matters of time and performance in this Contract.

21. APPLICABLE LAW: This Contract is governed by and interpreted under West Virginia law without giving effect to its choice of law principles. Any information provided in specification manuals, or any other source, verbal or written, which contradicts or violates the West Virginia Constitution, West Virginia Code or West Virginia Code of State Rules is void and of no effect.

22. COMPLIANCE WITH LAWS: Vendor shall comply with all applicable federal, state, and local laws, regulations and ordinances. By submitting a bid, Vendor acknowledges that it has reviewed, understands, and will comply with all applicable laws, regulations, and ordinances.

SUBCONTRACTOR COMPLIANCE: Vendor shall notify all subcontractors providing commodities or services related to this Contract that as subcontractors, they too are required to comply with all applicable laws, regulations, and ordinances. Notification under this provision must occur prior to the performance of any work under the contract by the subcontractor.

23. ARBITRATION: Any references made to arbitration contained in this Contract, Vendor's bid, or in any American Institute of Architects documents pertaining to this Contract are hereby deleted, void, and of no effect.

24. MODIFICATIONS: This writing is the parties' final expression of intent. Notwithstanding anything contained in this Contract to the contrary no modification of this Contract shall be binding without mutual written consent of the Agency, and the Vendor, with approval of the Purchasing Division and the Attorney General's office (Attorney General approval is as to form only). Any change to existing contracts that adds work or changes contract cost, and were not included in the original contract, must be approved by the Purchasing Division and the Attorney General's Office (as to form) prior to the implementation of the change or commencement of work affected by the change.

25. WAIVER: The failure of either party to insist upon a strict performance of any of the terms or provision of this Contract, or to exercise any option, right, or remedy herein contained, shall not be construed as a waiver or a relinquishment for the future of such term, provision, option, right, or remedy, but the same shall continue in full force and effect. Any waiver must be expressly stated in writing and signed by the waiving party.

26. SUBSEQUENT FORMS: The terms and conditions contained in this Contract shall supersede any and all subsequent terms and conditions which may appear on any form documents submitted by Vendor to the Agency or Purchasing Division such as price lists, order forms, invoices, sales agreements, or maintenance agreements, and includes internet websites or other electronic documents. Acceptance or use of Vendor's forms does not constitute acceptance of the terms and conditions contained thereon.

27. ASSIGNMENT: Neither this Contract nor any monies due, or to become due hereunder, may be assigned by the Vendor without the express written consent of the Agency, the Purchasing Division, the Attorney General's office (as to form only), and any other government agency or office that may be required to approve such assignments. Notwithstanding the foregoing, Purchasing Division approval may or may not be required on certain agency delegated or exempt purchases.

28. WARRANTY: The Vendor expressly warrants that the goods and/or services covered by this Contract will: (a) conform to the specifications, drawings, samples, or other description furnished or specified by the Agency; (b) be merchantable and fit for the purpose intended; and (c) be free from defect in material and workmanship.

29. STATE EMPLOYEES: State employees are not permitted to utilize this Contract for personal use and the Vendor is prohibited from permitting or facilitating the same.

30. BANKRUPTCY: In the event the Vendor files for bankruptcy protection, the State of West Virginia may deem this Contract null and void, and terminate this Contract without notice.

31. PRIVACY, SECURITY, AND CONFIDENTIALITY: The Vendor agrees that it will not disclose to anyone, directly or indirectly, any such personally identifiable information or other confidential information gained from the Agency, unless the individual who is the subject of the information consents to the disclosure in writing or the disclosure is made pursuant to the Agency's policies, procedures, and rules. Vendor further agrees to comply with the Confidentiality Policies and Information Security Accountability Requirements, set forth in <http://www.state.wv.us/admin/purchase/privacy/default.html>.

32. YOUR SUBMISSION IS A PUBLIC DOCUMENT: Vendor's entire response to the Solicitation and the resulting Contract are public documents. As public documents, they will be disclosed to the public following the bid/proposal opening or award of the contract, as required by the competitive bidding laws of West Virginia Code §§ 5A-3-1 et seq., 5-22-1 et seq., and 5G-1-1 et seq. and the Freedom of Information Act West Virginia Code §§ 29B-1-1 et seq.

DO NOT SUBMIT MATERIAL YOU CONSIDER TO BE CONFIDENTIAL, A TRADE SECRET, OR OTHERWISE NOT SUBJECT TO PUBLIC DISCLOSURE.

Submission of any bid, proposal, or other document to the Purchasing Division constitutes your explicit consent to the subsequent public disclosure of the bid, proposal, or document. The Purchasing Division will disclose any document labeled "confidential," "proprietary," "trade secret," "private," or labeled with any other claim against public disclosure of the documents, to include any "trade secrets" as defined by West Virginia Code § 47-22-1 et seq. All submissions are subject to public disclosure without notice.

33. LICENSING: In accordance with West Virginia Code of State Rules § 148-1-6.1 e, Vendor must be licensed and in good standing in accordance with any and all state and local laws and requirements by any state or local agency of West Virginia, including, but not limited to, the West Virginia Secretary of State's Office, the West Virginia Tax Department, West Virginia Insurance Commission, or any other state agency or political subdivision. Obligations related to political subdivisions may include, but are not limited to, business licensing, business and occupation taxes, inspection compliance, permitting, etc. Upon request, the Vendor must provide all necessary releases to obtain information to enable the Purchasing Division Director or the Agency to verify that the Vendor is licensed and in good standing with the above entities.

SUBCONTRACTOR COMPLIANCE: Vendor shall notify all subcontractors providing commodities or services related to this Contract that as subcontractors, they too are required to be licensed, in good standing, and up-to-date on all state and local obligations as described in this section. Obligations related to political subdivisions may include, but are not limited to, business licensing, business and occupation taxes, inspection compliance, permitting, etc. Notification under this provision must occur prior to the performance of any work under the contract by the subcontractor.

34. ANTITRUST: In submitting a bid to, signing a contract with, or accepting a Award Document from any agency of the State of West Virginia, the Vendor agrees to convey, sell, assign, or transfer to the State of West Virginia all rights, title, and interest in and to all causes of action it may now or hereafter acquire under the antitrust laws of the United States and the State of West Virginia for price fixing and/or unreasonable restraints of trade relating to the particular commodities or services purchased or acquired by the State of West Virginia. Such assignment shall be made and become effective at the time the purchasing agency tenders the initial payment to Vendor.

35. VENDOR CERTIFICATIONS: By signing its bid or entering into this Contract, Vendor certifies (1) that its bid or offer was made without prior understanding, agreement, or connection with any corporation, firm, limited liability company, partnership, person or entity submitting a bid or offer for the same material, supplies, equipment or services; (2) that its bid or offer is in all respects fair and without collusion or fraud; (3) that this Contract is accepted or entered into without any prior understanding, agreement, or connection to any other entity that could be considered a violation of law; and (4) that it has reviewed this Solicitation in its entirety; understands the requirements, terms and conditions, and other information contained herein.

Vendor's signature on its bid or offer also affirms that neither it nor its representatives have any interest, nor shall acquire any interest, direct or indirect, which would compromise the performance of its services hereunder. Any such interests shall be promptly presented in detail to the Agency. The individual signing this bid or offer on behalf of Vendor certifies that he or she is authorized by the Vendor to execute this bid or offer or any documents related thereto on Vendor's behalf; that he or she is authorized to bind the Vendor in a contractual relationship; and that, to the best of his or her knowledge, the Vendor has properly registered with any State agency that may require registration.

36. VENDOR RELATIONSHIP: The relationship of the Vendor to the State shall be that of an independent contractor and no principal-agent relationship or employer-employee relationship is contemplated or created by this Contract. The Vendor as an independent contractor is solely liable for the acts and omissions of its employees and agents. Vendor shall be responsible for selecting, supervising, and compensating any and all individuals employed pursuant to the terms of this Solicitation and resulting contract. Neither the Vendor, nor any employees or subcontractors of the Vendor, shall be deemed to be employees of the State for any purpose whatsoever. Vendor shall be exclusively responsible for payment of employees and contractors for all wages and salaries, taxes, withholding payments, penalties, fees, fringe benefits, professional liability insurance premiums, contributions to insurance and pension, or other deferred compensation plans, including but not limited to, Workers' Compensation and Social Security obligations, licensing fees, etc. and the filing of all necessary documents, forms, and returns pertinent to all of the foregoing.

Vendor shall hold harmless the State, and shall provide the State and Agency with a defense against any and all claims including, but not limited to, the foregoing payments, withholdings, contributions, taxes, Social Security taxes, and employer income tax returns.

37. INDEMNIFICATION: The Vendor agrees to indemnify, defend, and hold harmless the State and the Agency, their officers, and employees from and against: (1) Any claims or losses for services rendered by any subcontractor, person, or firm performing or supplying services, materials, or supplies in connection with the performance of the Contract; (2) Any claims or losses resulting to any person or entity injured or damaged by the Vendor, its officers, employees, or subcontractors by the publication, translation, reproduction, delivery, performance, use, or disposition of any data used under the Contract in a manner not authorized by the Contract, or by Federal or State statutes or regulations; and (3) Any failure of the Vendor, its officers, employees, or subcontractors to observe State and Federal laws including, but not limited to, labor and wage and hour laws.

38. PURCHASING AFFIDAVIT: In accordance with West Virginia Code § 5-22-1(i), the contracting public entity shall not award a contract for a construction project to any bidder that is known to be in default on any monetary obligation owed to the state or a political subdivision of the state, including, but not limited to, obligations related to payroll taxes, property taxes, sales and use taxes, fire service fees, or other fines or fees. Accordingly, prior to contract award, Vendors are required to sign, notarize, and submit the Purchasing Affidavit to the Purchasing Division affirming under oath that it is not in default on any monetary obligation owed to the state or a political subdivision of the state.

39. ADDITIONAL AGENCY AND LOCAL GOVERNMENT USE: This Contract may be utilized by other agencies, spending units, and political subdivisions of the State of West Virginia; county, municipal, and other local government bodies; and school districts (“Other Government Entities”). Any extension of this Contract to the aforementioned Other Government Entities must be on the same prices, terms, and conditions as those offered and agreed to in this Contract, provided that such extension is in compliance with the applicable laws, rules, and ordinances of the Other Government Entity. If the Vendor does not wish to extend the prices, terms, and conditions of its bid and subsequent contract to the Other Government Entities, the Vendor must clearly indicate such refusal in its bid. A refusal to extend this Contract to the Other Government Entities shall not impact or influence the award of this Contract in any manner.

40. CONFLICT OF INTEREST: Vendor, its officers or members or employees, shall not presently have or acquire an interest, direct or indirect, which would conflict with or compromise the performance of its obligations hereunder. Vendor shall periodically inquire of its officers, members and employees to ensure that a conflict of interest does not arise. Any conflict of interest discovered shall be promptly presented in detail to the Agency.

41. REPORTS: Vendor shall provide the Agency and/or the Purchasing Division with the following reports identified by a checked box below:

Such reports as the Agency and/or the Purchasing Division may request. Requested reports may include, but are not limited to, quantities purchased, agencies utilizing the contract, total contract expenditures by agency, etc.

Quarterly reports detailing the total quantity of purchases in units and dollars, along with a listing of purchases by agency. Quarterly reports should be delivered to the Purchasing Division via email at purchasing.requisitions@wv.gov.

42. BACKGROUND CHECK: In accordance with W. Va. Code § 15-2D-3, the Director of the Division of Protective Services shall require any service provider whose employees are regularly employed on the grounds or in the buildings of the Capitol complex or who have access to sensitive or critical information to submit to a fingerprint-based state and federal background inquiry through the state repository. The service provider is responsible for any costs associated with the fingerprint-based state and federal background inquiry.

After the contract for such services has been approved, but before any such employees are permitted to be on the grounds or in the buildings of the Capitol complex or have access to sensitive or critical information, the service provider shall submit a list of all persons who will be physically present and working at the Capitol complex to the Director of the Division of

Protective Services for purposes of verifying compliance with this provision. The State reserves the right to prohibit a service provider's employees from accessing sensitive or critical information or to be present at the Capitol complex based upon results addressed from a criminal background check.

Service providers should contact the West Virginia Division of Protective Services by phone at (304) 558-9911 for more information.

43. PREFERENCE FOR USE OF DOMESTIC STEEL PRODUCTS: Except when authorized by the Director of the Purchasing Division pursuant to W. Va. Code § 5A-3-56, no contractor may use or supply steel products for a State Contract Project other than those steel products made in the United States. A contractor who uses steel products in violation of this section may be subject to civil penalties pursuant to W. Va. Code § 5A-3-56. As used in this section:

- a. "State Contract Project" means any erection or construction of, or any addition to, alteration of or other improvement to any building or structure, including, but not limited to, roads or highways, or the installation of any heating or cooling or ventilating plants or other equipment, or the supply of and materials for such projects, pursuant to a contract with the State of West Virginia for which bids were solicited on or after June 6, 2001.
- b. "Steel Products" means products rolled, formed, shaped, drawn, extruded, forged, cast, fabricated or otherwise similarly processed, or processed by a combination of two or more or such operations, from steel made by the open heath, basic oxygen, electric furnace, Bessemer or other steel making process. The Purchasing Division Director may, in writing, authorize the use of foreign steel products if:
- c. The cost for each contract item used does not exceed one tenth of one percent (.1%) of the total contract cost or two thousand five hundred dollars (\$2,500.00), whichever is greater. For the purposes of this section, the cost is the value of the steel product as delivered to the project; or
- d. The Director of the Purchasing Division determines that specified steel materials are not produced in the United States in sufficient quantity or otherwise are not reasonably available to meet contract requirements.

44. PREFERENCE FOR USE OF DOMESTIC ALUMINUM, GLASS, AND STEEL: In Accordance with W. Va. Code § 5-19-1 et seq., and W. Va. CSR § 148-10-1 et seq., for every contract or subcontract, subject to the limitations contained herein, for the construction, reconstruction, alteration, repair, improvement or maintenance of public works or for the purchase of any item of machinery or equipment to be used at sites of public works, only domestic aluminum, glass or steel products shall be supplied unless the spending officer determines, in writing, after the receipt of offers or bids, (1) that the cost of domestic aluminum, glass or steel products is unreasonable or inconsistent with the public interest of the State of West Virginia, (2) that domestic aluminum, glass or steel products are not produced in sufficient quantities to meet the contract requirements, or (3) the available domestic aluminum, glass, or steel do not meet the contract specifications. This provision only applies to public works contracts awarded in an amount more than fifty thousand dollars (\$50,000) or public works contracts that require more than ten thousand pounds of steel products.

The cost of domestic aluminum, glass, or steel products may be unreasonable if the cost is more than twenty percent (20%) of the bid or offered price for foreign made aluminum, glass, or steel products. If the domestic aluminum, glass or steel products to be supplied or produced in a "substantial labor surplus area", as defined by the United States Department of Labor, the cost of domestic aluminum, glass, or steel products may be unreasonable if the cost is more than thirty percent (30%) of the bid or offered price for foreign made aluminum, glass, or steel products. This preference shall be applied to an item of machinery or equipment, as indicated above, when the item is a single unit of equipment or machinery manufactured primarily of aluminum, glass or steel, is part of a public works contract and has the sole purpose or of being a permanent part of a single public works project. This provision does not apply to equipment or machinery purchased by a spending unit for use by that spending unit and not as part of a single public works project.

All bids and offers including domestic aluminum, glass or steel products that exceed bid or offer prices including foreign aluminum, glass or steel products after application of the preferences provided in this provision may be reduced to a price equal to or lower than the lowest bid or offer price for foreign aluminum, glass or steel products plus the applicable preference. If the reduced bid or offer prices are made in writing and supersede the prior bid or offer prices, all bids or offers, including the reduced bid or offer prices, will be reevaluated in accordance with this rule.

45. INTERESTED PARTY SUPPLEMENTAL DISCLOSURE: W. Va. Code § 6D-1-2 requires that for contracts with an actual or estimated value of at least \$100,000, the vendor must submit to the Agency a supplemental disclosure of interested parties reflecting any new or differing interested parties to the contract, which were not included in the original pre-award interested party disclosure, within 30 days following the completion or termination of the contract. A copy of that form is included with this solicitation or can be obtained from the WV Ethics Commission. "Interested parties" means: (1) A business entity performing work or service pursuant to, or in furtherance of, the applicable contract, including specifically sub-contractors; (2) the person(s) who have an ownership interest equal to or greater than 25% in the business entity performing work or service pursuant to, or in furtherance of, the applicable contract; and (3) the person or business entity, if any, that served as a compensated broker or intermediary to actively facilitate the applicable contract or negotiated the terms of the applicable contract with the state agency: Provided, That subdivision (2) shall be inapplicable if a business entity is a publicly traded company: Provided, however, That subdivision (3) shall not include persons or business entities performing legal services related to the negotiation or drafting of the applicable contract. The Agency shall submit a copy of the disclosure to the Ethics Commission within 15 days after receiving the supplemental disclosure of interested parties.

DESIGNATED CONTACT: Vendor appoints the individual identified in this Section as the Contract Administrator and the initial point of contact for matters relating to this Contract.

(Name, Title)

Matt Cochran, Regional Sales Manager

(Printed Name and Title)

408 New Goff Mountain Rd, Cross Lanes, WV 25313

(Address)

304-345-2490 office, 304-208-2542 cell, 304-776-9319 fax

(Phone Number) / (Fax Number)

matt.cochran@thetruckpeople.com

(email address)

CERTIFICATION AND SIGNATURE: By signing below, or submitting documentation through wvOASIS, I certify that I have reviewed this Solicitation in its entirety; that I understand the requirements, terms and conditions, and other information contained herein; that this bid, offer or proposal constitutes an offer to the State that cannot be unilaterally withdrawn; that the product or service proposed meets the mandatory requirements contained in the Solicitation for that product or service, unless otherwise stated herein; that the Vendor accepts the terms and conditions contained in the Solicitation, unless otherwise stated herein; that I am submitting this bid, offer or proposal for review and consideration; that I am authorized by the vendor to execute and submit this bid, offer, or proposal, or any documents related thereto on vendor's behalf; that I am authorized to bind the vendor in a contractual relationship; and that to the best of my knowledge, the vendor has properly registered with any State agency that may require registration.

Worldwide Equipment

(Company)

 Reg. Sales Mgr.

(Authorized Signature) (Representative Name, Title)

Matt Cochran, Regional Sales Manager

(Printed Name and Title of Authorized Representative)

6-14-18

(Date)

304-345-2490 office, 304-208-2542 cell, 304-776-9319 fax

(Phone Number) (Fax Number)

REQUEST FOR QUOTATION
CRFQ 0803 DOT1800000097
(332 Class) 60,000 GVWR Tandem Axle Truck with 23-ton Crane

SPECIFICATIONS

1. **PURPOSE AND SCOPE:** The West Virginia Purchasing Division is soliciting bids on behalf of the West Virginia Division of Highways, Department of Transportation to establish an open-end contract for a 60,000 GVWR Tandem Axle Straight Truck with 23-ton behind cab Crane with Outriggers.

2. **DEFINITIONS:** The terms listed below shall have the meanings assigned to them below. Additional definitions can be found in section 2 of the General Terms and Conditions.
 - 2.1 **“Contract Item” or “Contract Items”** means the list of items identified in Section 3.1, below and on the Pricing Pages.
 - 2.2 **“Pricing Pages”** means the schedule of prices, estimated order quantity, and totals contained in wvOASIS or attached hereto as Exhibit A, and used to evaluate the Solicitation response.
 - 2.3 **“Solicitation”** means the official notice of an opportunity to supply the State with goods or services that is published by the Purchasing Division.
 - 2.4 **“G.V.W.”** means gross vehicle weight.
 - 2.5 **“G.V.W.R”** means gross vehicle weight rating.
 - 2.6 **“Lbs.”** means pounds.
 - 2.7 **“PSI”** means pounds per square inch.
 - 2.8 **“WVDOH”** means West Virginia Division of Highways.
 - 2.9 **“R.B.M.”** means Resisting Bending Moment.
 - 2.10 **“PTO”** means power take off.
 - 2.11 **“RPM”** means revolutions per minute.
 - 2.12 **“HP”** means horse power.
 - 2.13 **“F”** means Fahrenheit.
 - 2.14 **“FMVSS”** means Federal Motor Vehicle Safety Standards.
 - 2.15 **“CCA”** means cold cranking amps.
 - 2.16 **“SAE”** means Society of Automotive Engineers.

**REQUEST FOR QUOTATION
CRFQ 0803 DOT1800000097
(332 Class) 60,000 GVWR Tandem Axle Truck with 23-ton Crane**

- 2.17 “ABS” means Antilock Braking System.
- 2.18 “MPH” means miles per hour.
- 2.19 “cu. ft.” means cubic feet.
- 2.20 “mm” means millimeter.
- 2.21 “cu. yd.” means cubic yard.
- 2.22 “OSHA” means Occupational Safety and Health Act.
- 2.23 “I.D.” means inner diameter.
- 2.24 “GPM” means gallons per minute.
- 2.25 “LED” means light emitting diode.
- 2.26 “C” means Celsius.
- 2.28 “SS” means Stainless Steel
- 2.29 “OD” means Outside Diameter
- 2.30 “CA” means cab to axle.
- 2.31 “CT” means cab to trunnion.
- 2.32 “12 VDC” means 12-volt direct current.
- 2.33 “OEM” means Original Equipment Manufacturer.
- 2.34 “BTU” means British Thermal Unit.
- 2.35 “USB” means Universal Serial Bus.
- 2.36 “Class 332” is an internal classification used by the WVDOH only.

3. GENERAL REQUIREMENTS:

- 3.1 **Contract Items and Mandatory Requirements:** Vendor shall provide Agency with the Contract Items listed below on an open-end and continuing basis. Contract Items must meet or exceed the mandatory requirements as shown below.

**REQUEST FOR QUOTATION
CRFQ 0803 DOT1800000097
(332 Class) 60,000 GVWR Tandem Axle Truck with 23-ton Crane**

3.1.1 Cab and Chassis

3.1.1.1 The GVWR rating shall be 60,000 Lbs., minimum rating.

3.1.1.2 Wheelbase and CT shall be determined by Crane body manufacturer.

3.1.1.3 Wheelbase and CT dimension shall be adjusted to provide the best legal weight distribution. Chassis OEM and body company are responsible for coordinating the correct CT calculations.

3.1.1.4 The unit specified herein and offered shall be manufactured on or after January 1, 2019 and will be clearly identified and marked with date of manufacturer.

3.1.2 Frame and Front Bumper:

3.1.2.1 The manufacturer shall provide a frame that meets or exceeds all Federal requirements for G.V.W.R.

3.1.2.2 Frame material shall be single frame minimum 120,000 PSI yield strength.

3.1.2.3 R.B.M: Minimum 2,820,000 Ins./Lb. per rail. An integral frame and frame extension is mandatory.

3.1.2.4 Frame shall have two (2) front frame mounted tow hooks.

3.1.2.5 Shall have manufacturers front bumper with cutouts to access front tow hooks.

3.1.2.6 Front Frame and Bumper shall accept front mounted outrigger for crane.

3.1.3 Cab

3.1.3.1 The cab shall be manufacturers' galvanized steel, galvanneal steel or aluminum.

3.1.3.2 Hood shall be fiberglass one piece tilting hood. Fenders shall be part of tilting hood.

**REQUEST FOR QUOTATION
CRFQ 0803 DOT1800000097
(332 Class) 60,000 GVWR Tandem Axle Truck with 23-ton Crane**

- 3.1.3.3** Mud flaps and/or fender extensions shall be provided and installed on the cab behind the left and right front tires.
- 3.1.3.4** Cab shall have rear air bag suspension, factory installed.
- 3.1.3.5** Cab shall have air ride high back seats with folding armrest, black cloth, with lumbar, with integrated cushion extensions, with forward and rear cushion tilt – Driver and Passenger side.
- 3.1.3.6** Cab Interior Floor Mat shall have rubber floor mat throughout cab area with non-absorbent backing under the mat.
- 3.1.3.7** Cab shall have highest output available by manufacturers, Air Conditioning with/integral heater and defroster and minimum of one replaceable fresh air filter.
- 3.1.3.8** Windshield Wipers shall be winter blade type with heaviest arms, linkages and motor available by manufacture.
- 3.1.3.9** Wipers shall be minimum of 2-speeds, electric with intermittent feature.
- 3.1.3.10** Washer system shall be electric with largest capacity reservoir available by manufacturer.

3.1.4 Instruments: The following instruments shall be contained in the truck cab.

- 3.1.4.1** Coolant gauge and oil pressure gauge shall have both dial type readout and either an audible or visual alarm to warn operator when safe operating conditions are exceeded.
- 3.1.4.2** Voltmeter or Ammeter gauge
- 3.1.4.3** Engine RPM Tachometer
- 3.1.4.4** Speedometer with odometer.
- 3.1.4.5** Primary Air Pressure Gauge/Auxiliary Air Pressure Gauge.

REQUEST FOR QUOTATION
CRFQ 0803 DOT1800000097
(332 Class) 60,000 GVWR Tandem Axle Truck with 23-ton Crane

3.1.4.6 Air filter restriction indicator gauge dash or air cleaner mounted.

3.1.4.7 Engine hour meter and PTO hour meter (Controlled by engine operation, not by key switch).

3.1.4.8 Must have Fuel level gauge and diesel exhaust fluid gauge.

3.1.4.9 Manufacturers best sound/weather insulation package for proposed cab.

3.1.4.10 Cab shall have transmission temperature gauge.

3.1.5 Accessories: The following accessories must be included with the truck cab & chassis:

3.1.5.1 Cab shall have minimum of one air horn cab mounted.

3.1.5.2 Right side and left side cab mirrors: Cab mirrors shall be west coast type 7 inches wide minimum x 16 inches high minimum, power adjustable with fore and after breakaway arms. 8 inches minimum convex spot mirror. Both mirrors must be heated type with all arms, hardware and fasteners corrosion resistant.

3.1.5.3 Shall have down view mirror, right hand side only.

3.1.5.4 Grab handles shall be supplied on all cab entry locations. Three points of contact shall be achievable at all cab entry locations.

3.1.5.5 The cab shall have the manufacturer's standard tinted safety glass installed throughout the front, sides and rear.

3.1.5.6 The front windshield shall be heated.

3.1.5.7 The cab shall have dual power windows.

3.1.5.8 The cab shall have manufacturer's standard AM/FM/Weather Band/Clock with wireless connectivity.

3.1.5.9 CB mounting provisions on top of dash and/or overhead console with power and ground.

**REQUEST FOR QUOTATION
CRFQ 0803 DOT1800000097
(332 Class) 60,000 GVWR Tandem Axle Truck with 23-ton Crane**

- 3.1.5.10** CB antenna mounted and wired.
- 3.1.5.11** Radio antenna shall be separate from CB antenna.
- 3.1.5.12** Cab shall contain a DOT approved emergency triangle warning kit.
- 3.1.5.13** The cab shall have a mounted 5 lbs. maximum fire extinguisher with A, B and C rating.
- 3.1.5.14** Cab shall have a minimum of four (4) additional switches.
- 3.1.5.15** Cab shall have OEM PTO switch.
- 3.1.5.16** Accessories not indicated above but are included in the manufacturer's standard model bid must be provided.

3.1.6 Engine:

- 3.1.6.1** The engine shall be a diesel powered.
- 3.1.6.2** 8.9 liter minimum
- 3.1.6.3** Minimum of 6 cylinders
- 3.1.6.4** Minimum HP370
- 3.1.6.5** Minimum torque 1250 LB/FT
- 3.1.6.6** Engine Compression Brake: Must be full engine compression brake minimum 2 stages with selector switch and on/off power switch and shall be dash mounted.
- 3.1.6.7** Air filter shall be largest volume available offered by manufacturer for severe duty conditions.
- 3.1.6.8** Engine shall have a Phillips-Temro or equal 1000 watt/120-volt block heater with corrosion resistant weather proof receptacle housing located on left side of cab. The engine block heater and the fuel water separator overnight heater shall be powered via the same electrical connection.

REQUEST FOR QUOTATION
CRFQ 0803 DOT1800000097
(332 Class) 60,000 GVWR Tandem Axle Truck with 23-ton Crane

3.1.6.9 Engine shall have a Davco Fuel Pro or Equal water separator with 120-volt overnight heater and 12-volt DC pre-heater. The engine fuel water overnight heater and the engine block heater shall be powered via the same electrical connection.

3.1.7 Exhaust System:

3.1.7.1 Manufacturers vertical side of cab exhaust for model bid. Exhaust system shall not interfere with the crane body or equipment.

3.1.7.2 Exhaust shall be stainless steel or aluminized pipe with all clamps and fasteners being stainless steel.

3.1.8 Cooling System:

3.1.8.1 The largest available engine cooling capacity, factory compatible with engine and transmission referenced for continuous high engine output under extreme temperatures and/or operating conditions.

3.1.8.1.1 It shall be fitted with provisions for visually monitoring coolant without necessitating removal of the cap from the radiator or expansion tank.

3.1.8.2 Antifreeze shall be extended life with a minimum of -34 degrees and shall meet all applicable Environmental Protection Agency (EPA) requirements.

3.1.8.3 A non-charged spin-on coolant filter shall be installed if required by engine manufacturer.

3.1.8.4 Radiator corrosion resistant screen guard or equal shall protect radiator from foreign objects.

3.1.8.5 All coolant hoses shall be Gates blue stripe or equal.

3.1.8.6 All hose clamps shall be corrosion resistant.

3.1.9 Fuel Tank:

3.1.9.1 Fuel Tank must comply with FMVSS.

REQUEST FOR QUOTATION
CRFQ 0803 DOT180000097
(332 Class) 60,000 GVWR Tandem Axle Truck with 23-ton Crane

3.1.9.2 Single aluminum 110-gallon minimum fuel tank, shall be mounted left side, under cab, frame-mounted with stainless steel mounting straps.

3.1.9.3 Must have driver and passenger entrance steps, stainless steel or aluminum grated self-cleaning safety steps.

3.1.10 Transmission Allison 3000 RDS or equal:

3.1.10.1 Transmission shall be fully automatic with torque converter.

3.1.10.2 Transmission shall have provision for PTO.

3.1.10.3 Shall have a transmission shift pad/shift selector, with oil life monitor; filter life monitor and transmission health monitor, lighted and dash or console mounted in cab.

3.1.10.4 Transmission shall have largest available approved transmission cooler for transmission provided.

3.1.10.4.1 All cooler hard lines must be corrosion resistant.

3.1.10.5 Transmission (TCM) Transmission control module shall be located in cab.

3.1.11 Driveline:

3.1.11.1 Driveline must be compatible to engine, drivetrain and transmission torque. If required by manufacturer, driveline shall have center carrier bearing.

3.1.12 Tandem Rear Axle:

3.1.12.1 Shall be single reduction with a power divider lockout, dash controlled, minimum rating of 40,000 lbs.

3.1.12.2 Axle ratio and top MPH parameters to be determined at pre-build meeting.

REQUEST FOR QUOTATION
CRFQ 0803 DOT1800000097
(332 Class) 60,000 GVWR Tandem Axle Truck with 23-ton Crane

3.1.13 Rear Suspension:

3.1.13.1 Shall have multi-leaf spring type rated for 40,000 lb. minimum capacity.

3.1.14 Front Axle:

3.1.14.1 Shall have minimum capacity of 20,000 lb.

3.1.14.2 Shall have right and left shock absorbers rated for 20,000 lb. minimum axle.

3.1.15 Front Suspension:

3.1.15.1 Shall have 10,000 lb. minimum capacity at ground on each front spring, total spring capacity 20,000 lb. minimum.

3.1.15.2 Spring hangers shall be heaviest available by manufacturer.

3.1.16 Steering:

3.1.16.1 Shall have right and left steering gear dual power which meets or exceeds a 20,000-lb. front axle.

3.1.17 Brakes and Air System:

3.1.17.1 Brakes shall be full air, with manufacturer's ABS.

3.1.17.2 Compressor shall be manufacturer's largest available for model bid. Shall have air dryer compatible with heater and spin on cartridge filter.

3.1.17.3 Rear parking brakes shall be spring loaded.

3.1.17.4 Rear service brake chambers and spring brake chambers shall be mounted to provide clearance for tire chains.

3.1.17.5 Air tanks shall be frame mounted, aluminum or stainless steel with drain valve.

REQUEST FOR QUOTATION
CRFQ 0803 DOT1800000097
(332 Class) 60,000 GVWR Tandem Axle Truck with 23-ton Crane

3.1.17.6 Unit shall be equipped with hand control valve, tractor protection valve, with swivel glad hands at rear of truck to enable unit to pull air operated equipment trailer.

3.1.17.7 Shall have low warning air pressure warning light and buzzer.

3.1.17.8 Front brakes: shall be full air powered disc or drum brakes.

3.1.17.9 Rear brakes shoes shall be full air powered disc or drum.

3.1.17.10 All brakes shall have automatic slack adjuster with stainless steel yokes and pins.

3.1.18 Trailer Tow Package shall include the following:

3.1.18.1 The truck shall be equipped with a full trailer air brake package. The glad hand connections shall be located at the rear of truck and located with red (emergency) on driver's side and blue (service) on passenger side. Glad hands shall be swivel design.

3.1.18.2 Truck shall be equipped with air actuated electric trailer brake controller, mounted in cab.

3.1.18.3 There shall be two 7-pole female trailer connectors with round brass inserts mounted in a corrosion resistant housing. One shall be for trailer lighting with electric brakes and one for trailer lighting with air brakes. Both connectors shall be color coded or labeled.

3.1.19 Tires and Wheels:

3.1.19.1 The truck shall be equipped with front and rear hub piloted aluminum wheels, preferably Alcoa or equal, with corrosion coating.

3.1.19.2 Wheels front and rear shall have correct rating for the GVWR of truck.

3.1.19.3 Front steer tires shall be 315/80/R22.5 with correct load range and ply rating for the GVWR of truck, preferably Goodyear brand or equal.

REQUEST FOR QUOTATION
CRFQ 0803 DOT1800000097
(332 Class) 60,000 GVWR Tandem Axle Truck with 23-ton Crane

3.1.19.4 Rear drive tires shall be a mud and snow tread 11R/22.5 with correct load range and ply rating for the GVWR of truck, preferably Goodyear brand or equal.

3.1.19.5 All tires shall be radial.

3.1.19.6 The dual rear wheel/tire assembly shall have clearance between the tires, which permits the use of dual tire chain.

3.1.19.7 Wheel guard separators shall be installed between wheels and wheel hub front and rear.

3.1.20 Electrical System & Lighting:

3.1.20.1 Shall have manufacturer's 12-volt negative ground system with manufacturer's radio interference suppression.

3.1.20.2 Shall have minimum of three (3) group 31 12- volt maintenance free Batteries total CCA of 3375 with threaded studs.

3.1.20.3 Alternator capacity shall be 160 AMPS minimum with internal regulator.

3.1.20.4 Cab and chassis must have best available wiring shield available by manufacturer.

3.1.20.5 The cab and chassis shall have:

3.1.20.5.1 Day time running lights

3.1.20.5.2 LED cab marker lights.

3.1.20.5.3 Halogen head lamps

3.1.20.5.4 Park and turn signals

REQUEST FOR QUOTATION
CRFQ 0803 DOT1800000097
(332 Class) 60,000 GVWR Tandem Axle Truck with 23-ton Crane

3.1.21 Paint, Decals and Logos:

3.1.21.1 The cab exterior and interior paint shall be base coat clear coat urethane paint yellow/gold, DuPont F9885, Sherwin Williams 73266, Sikkens 4017, PPG 85246 or Napa 73266.

3.1.21.2 The cab grill shall be manufacturer's standard stainless steel or impact resistant composite plastic.

3.1.21.3 The cab shall not be painted over top another finished color.

3.1.21.4 Chassis paint shall be urethane base, chassis color black.

3.1.22 Power Take Off and Hydraulics

3.1.22.1 Power take off shall be made of cast iron.

3.1.22.2 Unit shall be capable of mounting to fully automatic style transmission.

3.1.22.3 PTO shall be of the Hot Shift design and have a rotatable direct mount cast iron flange for the hydraulic pump to mate to. Shall be of the Wet Spline design, PTO/pump shafts are bathed in oil.

3.1.22.4 PTO to engine speed shall be in the maximum range of 116% to 120%.

3.1.22.5 Unit shall have in internal solenoid shifting coil no external shifting is acceptable.

3.1.22.6 PTO must have automatic shutdown with override switch for low oil and hot oil conditions.

3.1.22.7 PTO must have a minimum continuous torque rating of 390lb.ft.

3.1.23 Hydraulic Pump:

3.1.23.1 The hydraulic pump shall have a minimum displacement of 75cc.

REQUEST FOR QUOTATION
CRFQ 0803 DOT1800000097
(332 Class) 60,000 GVWR Tandem Axle Truck with 23-ton Crane

- 3.1.23.2** The hydraulic pump shall be direct flange mount to PTO.
- 3.1.23.3** The piston pump (load sensing type) must be capable of 48 GPM and a minimum of 3000 PSI at 2500 RPM.
- 3.1.23.4** Pump must have rear ports to avoid multiple 90-degree bends in suction line.
- 3.1.23.5** The case drain must be positioned as high as possible and directed back to the reservoir without passing through the return line filter.
- 3.1.23.6** Pump must have #24 minimum size O-ring port with 2" minimum barb fitting, for suction port and 1" minimum O-ring pressure port.
- 3.1.23.7** Pump must be all cast iron design.
- 3.1.23.8** The pump must have internal bleed down compensator option.
- 3.1.23.9** Compensator shall have 2 ports to choose from for the load sense line for ease of installation.
- 3.1.23.10** Shall have a minimum of 90-gallon reservoir.
- 3.1.23.11** Hydraulics shall have a single 90,000 BTU cooler minimum.

3.1.25 Behind Cab Crane ALTEC AC23-95 or Equal:

- 3.1.25.1** Crane shall have minimum lift capacity of 23 tons
- 3.1.25.2** Boom length shall be a minimum of 94 foot, 4-section boom
- 3.1.25.3** Boom shall have load protection system that includes Rated Capacity Limiter and working area audible alarm set points. includes boom angle, length and rotational position.
- 3.1.25.4** Boom shall have a minimum rotation of 370 degree with a mechanical stop.
- 3.1.25.5** Winch shall be single speed with burst of speed, 12000lb minimum line pull on bare drum, mounted at base of boom.

**REQUEST FOR QUOTATION
CRFQ 0803 DOT1800000097
(332 Class) 60,000 GVWR Tandem Axle Truck with 23-ton Crane**

- 3.1.25.6** Winch Shall have rotation resistant wire rope minimum of 350 feet 9/16" minimum diameter with load ball for 9/16-inch rope.
- 3.1.25.7** Shall have lower winch controls located at hook stowage point.
- 3.1.25.8** Winch drum shall have winch drum rotation indicator.
- 3.1.25.9** Shall have anti-Two block device.
- 3.1.25.10** Hydraulic system shall be pilot operated control valves at the control station.
- 3.1.25.11** Control Station shall have Curbside and StreetSide walk through control stations.
- 3.1.25.12** Operator controls shall include the following: Emergency Stop, engine Start/stop and crane outrigger mode switches
- 3.1.25.13** Outriggers shall have an Interlock system to prevent usage of boom without all outriggers deployed.
- 3.1.25.14** Outrigger shall have motion alarm while outriggers are being deployed.
- 3.1.25.15** Shall have primary and auxiliary outriggers with out and down and minimum of one front mount.
- 3.1.25.16** Outrigger controls shall be electric over hydraulic located at each rear corner of tail-shelf.
- 3.1.25.17** Shall have foot throttle at stand-up control stations.
- 3.1.25.18** Shall have a team wireless system to include 3-apex 3-series wireless headsets with com-hub and 2-way radio Sonetics Model# SONPWS-DECT7 or equal with cab mounted battery charger.
- 3.1.25.19** Shall have PTO hour meter installed in cab.
- 3.1.25.20** Unit shall have diagnostic pressure test ports with quick disconnect couplings for checking pressures of unit.

REQUEST FOR QUOTATION
CRFQ 0803 DOT1800000097
(332 Class) 60,000 GVWR Tandem Axle Truck with 23-ton Crane

3.1.25.21 Unit shall have two minimum radio remote controls with charging stations.

3.1.25.22 Shall have load block rated for capacity of crane.

3.1.26 Bed Body and Chassis Accessories:

3.1.26.1 Bed body shall be a minimum of 22-foot extruded aluminum alloy 6063 T-6 with tensile strength rating of 35,000 PSI minimum flatbed with non-skid Coating to all walking surfaces with rub rail and standards built in rail.

3.1.26.1.1 I-Beam Floor Support shall be Aluminum Extrusion Alloy 6005A T61 with tensile strength rating of 38,000psi minimum.

3.1.26.1.2 Rub Rail /Outer Perimeter Aluminum extrusion shall be alloy 6005a T61 with tensile strength rating of 38,000 psi minimum.

3.1.26.2 Shall have Underride Protection Bumper installed at rear painted with spray liner.

3.1.26.3 Shall have Buyers PH20 or equal style pintle hitch (minimum 40,000lb.)

3.1.26.4 Shall have minimum one-inch D-rings installed on each side of towing Device mount for safety chains.

3.1.26.5 Shall have removable Boom rest.

3.1.26.6 Shall have 7-way round corrosion resistant trailer receptacle mounted rear of truck.

3.1.26.7 Shall have minimum of 2-pair of wheel chocks with holders.

3.1.26.8 Shall have composite or board matting pads with the proper size and rating for the crane with storage holders.

3.1.26.9 Shall be two right and two left side stainless steel mounted toolboxes for storage minimum size of 36 inches wide x 16 inches tall x 16 inches deep or equal.

3.1.26.9.1 Locations to be determined at pre-build meeting.

**REQUEST FOR QUOTATION
CRFQ 0803 DOT1800000097
(332 Class) 60,000 GVWR Tandem Axle Truck with 23-ton Crane**

3.1.26.10 Shall have a 2-man fixed steel platform option 750lbs. minimum capacity.

3.1.26.11 Shall be plumbed for hydraulic tool circuit at tail shelf.

3.1.26.12 Body shall have lights and reflectors in accordance with FMVSS#108 light package (complete LED including reverse lights).

3.1.26.13 Shall have 6 oval LED strobe lights: 2-on rear of truck, 2-on sides and 2-on front of truck minimum size 1-5/8-inch-high X 5-inches wide Whelen 500 series or equal.

3.1.26.14 Shall have minimum of 4-LED rear floodlights Hella Brand# H71030401 or equal.

3.1.27 Hydraulic Test and Inspection:

3.1.27.1 Any items not specifically stated herein, but necessary for proper system operation, shall comply with recommended hydraulic industry standards. The vendor shall be responsible for pre-testing of hydraulic system which shall include the following: A startup and initial high pressure run of all hydraulic system components shall be done to check for leaks, heat buildup, system efficiency, pressure settings, etc.

3.1.28 Miscellaneous Information:

3.1.28.1 The vendor is responsible to furnish a truck that is properly engineered and that conforms to all and any laws governing such equipment.

3.1.29 Unspecified Accessories & Features:

3.1.29.1 All parts, equipment, accessories, materials, design and performance characteristics not specified herein, but which are necessary to provide a complete unit, must be furnished with each unit and required to conform to strength, quality of material, and quality of workmanship to those which are advertised and provided to the market in general by the unit Industry. All parts and accessories advertised and regularly supplied as standard shall be included, except those which would represent duplication of these specified and except those which, by specification, are not to be furnished. All standard

REQUEST FOR QUOTATION
CRFQ 0803 DOT1800000097
(332 Class) 60,000 GVWR Tandem Axle Truck with 23-ton Crane

safety features, required by Federal and State Law, shall be included.

3.1.30 Pre-Build Meeting:

3.1.30.1 After award of contract there will be a mandatory pre-build meeting with successful vendor, manufacturers and up fitters at the WVDOT/Equipment Division, 83 Brushy Fork Rd. Crossing, Buckhannon WV or successful vendors location.

4. CONTRACT AWARD:

4.1 Contract Award: The Contract is intended to provide Agencies with a purchase price on all Contract Items. The Contract shall be awarded to the Vendor that provides the Contract Items meeting the required specifications for the lowest overall total cost as shown on the Pricing Pages.

4.2 Pricing Pages: Vendor should complete the Pricing Pages in wvOasis by completing the Year, Make, Model and inserting quoted Unit Price. If submitting on paper, Vendor should complete the Exhibit_A Pricing Page by completing the Year, Make, Model and inserting quoted Unit Price. The Exhibit_A Pricing Page is provided in Excel and formatted to automatically calculate the Grand Total Cost. However, it is the vendors responsibility to ensure the calculations for their bid is correct before submitting. In the event of an error, the Unit Price shall prevail. Vendor should complete the Pricing Pages in their entirety as failure to do so may result in Vendor's bids being disqualified.

The Pricing Pages contain a list of the Contract Items and estimated purchase volume. The estimated purchase volume for each item represents the approximate volume of anticipated purchases only. No future use of the Contract or any individual item is guaranteed or implied.

Vendor should electronically enter the information into the Pricing Pages through wvOASIS, if available, or as an electronic document.

5. ORDERING AND PAYMENT:

5.1 Ordering: Vendor shall accept orders through wvOASIS, regular mail, facsimile, e-mail, or any other written form of communication. Vendor may, but is not required to, accept on-line orders through a secure internet ordering portal/website. If Vendor

REQUEST FOR QUOTATION
CRFQ 0803 DOT1800000097
(332 Class) 60,000 GVWR Tandem Axle Truck with 23-ton Crane

has the ability to accept on-line orders, it should include in its response a brief description of how Agencies may utilize the on-line ordering system. Vendor shall ensure that its on-line ordering system is properly secured prior to processing Agency orders on-line.

- 5.2 Payment:** Vendor shall accept payment in accordance with the payment procedures of the State of West Virginia.

6. DELIVERY AND RETURN:

- 6.1 Delivery Time:** Vendor shall deliver standard orders within **270 calendar days** after orders are received. Vendor shall ship all orders in accordance with the above schedule and shall not hold orders until a minimum delivery quantity is met. A completed pilot model for inspection must be provided within **175 calendar days** after receipt of the purchase agreement by the successful vendor.

- 6.2 Late Delivery:** The Agency placing the order under this Contract must be notified in writing if orders will be delayed for any reason. Any delay in delivery that could cause harm to an Agency will be grounds for cancellation of the delayed order, and/or obtaining the items ordered from a third party.

Any Agency seeking to obtain items from a third party under this provision must first obtain approval of the Purchasing Division.

- 6.3 Delivery Payment/Risk of Loss:** Standard order delivery shall be F.O.B. destination to the Agency's location. Vendor shall include the cost of standard order delivery charges in its bid pricing/discount and is not permitted to charge the Agency separately for such delivery.

- 6.4 Representative Unit for Test:** The successful vendor must (if specified) provide the DOH one (1) completed represented unit to be observed and evaluated on each order to insure compliance with specification. If requested, the time for testing and evaluation shall be seven (7) working days following receipt of the unit. DOH will incur no obligation for deterioration of surfaces, finishes, seals, and mechanical or electrical parts on the unit resulting from operation and testing within the limits of these specifications; nor will DOH incur obligation for damage to the unit resulting from failure to meet specifications when due care and attention is given by DOH and testing is done within the limits of these specifications. Failure of the pilot unit to satisfactorily meet specifications as bid may be cause for cancellation of the purchase order, and return of the delivered unit along with all associated equipment to the vendor at the vendor's expense.

**REQUEST FOR QUOTATION
CRFQ 0803 DOT1800000097
(332 Class) 60,000 GVWR Tandem Axle Truck with 23-ton Crane**

6.5 Condition of Unit(s) Upon Delivery: All units must arrive at the prescribed delivery point having been completely pre-serviced with oil, lubricants, and coolant. All prescribed precautions pertaining to first operations and break-in of the unit are to be posted conspicuously on the unit for ready observance by the operator.

6.6 Delivery Point: Delivery point of the completed representative unit will be the WVDOH, Equipment Division, 83 Brushy Fork Crossing, Buckhannon, WV 26201.

7. VENDOR DEFAULT:

7.1The following shall be considered a vendor default under this Contract.

7.1.1 Failure to provide Contract Items in accordance with the requirements contained herein.

7.1.2 Failure to comply with other specifications and requirements contained herein.

7.1.3 Failure to comply with any laws, rules, and ordinances applicable to the Contract Services provided under this Contract.

7.1.4 Failure to remedy deficient performance upon request.

7.2 The following remedies shall be available to Agency upon default.

7.2.1 Immediate cancellation of the Contract.

7.2.2 Immediate cancellation of one or more release orders issued under this Contract.

7.2.3 Any other remedies available in law or equity.

8. MISCELLANEOUS:

8.1 No Substitutions: Vendor shall supply only Contract Items submitted in response to RFQ unless a contract modification is approved in accordance with the provisions contained in this contract.

REQUEST FOR QUOTATION
CRFQ 0803 DOT1800000097
(332 Class) 60,000 GVWR Tandem Axle Truck with 23-ton Crane

8.2 Reports: Vendor shall provide quarterly reports and annual summaries to the Agency showing the Agency's items purchased, quantities of items purchased, and total dollar value of the items purchased. Vendor shall also provide reports, upon request, showing the items purchased during the term of this Contract, the quantity purchased for each of those items, and the total value of purchases for each of those items. Failure to supply such reports may be grounds for cancellation of this Contract.

8.3 Contract Manager: During its performance of this Contract, Vendor must designate and maintain a primary contract manager responsible for overseeing Vendor's responsibilities under this Contract. The Contract manager must be available during normal business hours to address any customer service or other issues related to this Contract. Vendor should list its Contract manager and his or her contact information below.

Contract Manager: Matt Cochran
Telephone Number: 304-208-2542
Fax Number: 304-759-9807
Email Address: matt.cochran@thetruckpeople.com

8.4 Operating and Service Manuals and Parts Lists: An operator's manual must be included with each unit upon delivery. A "line sheet" (if applicable) and the "Equipment Preventative Maintenance Questionnaire", (**Exhibit "B"**) must be with pilot unit upon delivery. Attn: Marcia Lee. There must be 12 service/shop/maintenance manuals and 14 parts manuals; CD-ROM is preferred in lieu of parts manuals. Manuals shall be delivered upon completion of delivery of total units. Failure to do so will delay payment.

8.5 Training: Manufacturers and/or dealers will be required to stage a thorough seminar on the subjects of Preventative Maintenance, Operator, and Mechanic Training. In order to keep operators and mechanics updated, the successful vendor shall conduct training sessions covering the operation, maintenance, trouble-shooting with each purchase order against this open end contract. Manufacturers and/or dealers shall be required to furnish the Training Academy with one (1) Operator's Manual to be shipped direct to:

WVDOH
Training Academy
P.O. Box 610
Buckhannon, West Virginia 26201

A training seminar to be held at the WVDOT, Equipment Division, Buckhannon, WV, after receiving the pilot unit.

REQUEST FOR QUOTATION
CRFQ 0803 DOT180000097
(332 Class) 60,000 GVWR Tandem Axle Truck with 23-ton Crane

8.6 Preventative Maintenance & Operator Procedures: Manufacturers and/or dealers will be required to submit to the Equipment Division, in addition to the operating and service manuals, booklets and pamphlets explaining the Preventative Maintenance and Operator Procedures to be used by the operators of this equipment, and must include such things as daily prestart inspection procedure, service schedule, and routine maintenance required, safety precautions, etc. The successful vendor shall furnish all training aids; i.e. videos, projectors as required in conducting the training.

8.7 Warranty:

8.7.1 Bumper to Bumper:

1-year warranty shall start on the final date of acceptance for the entire order.

8.7.2 Engine Warranty:

100% Parts and Labor for 60 months 150,000 Mile Engine Warranty, 5500 hours. Engine block shall be warranted against external perforation from corrosion for 60 months 100% parts and labor.

8.7.2.1 Oil pan and hardware shall have 100% parts and labor, full replacement warranty for 60 months on any type rust/corrosion regardless of atmospheric conditions. Failure of oil pan from rust thru that causes catastrophic Engine Failure Engine shall be covered 100% parts and labor.

8.7.2.2 All engine coolant piping/tubing shall be warranty for 60 months 100% parts and labor full replacement on rust/corrosion. Failure of any coolant piping causing catastrophic engine failure, Engine shall be covered 100% parts and labor.

8.7.3 Emissions Warranty:

100% Parts and Labor for all emission related components to include the DPF for 60 Months 150,000 miles or 5500 engine hours. Shall be warranted against corrosion, rust, rust thru etc. regardless of atmospheric conditions.

REQUEST FOR QUOTATION
CRFQ 0803 DOT1800000097
(332 Class) 60,000 GVWR Tandem Axle Truck with 23-ton Crane

8.7.4 Transmission Warranty:

100% Parts and Labor for 2 years unlimited mileage and hours. The transmission shall include all internal and external components related to the automatic transmission. This warranty shall also include, but not limited to, the transmission cooler, cooler hoses or lines, and all electrical transmission controls, harnesses, connections and modules regardless of atmospheric conditions.

8.7.5 Radiator Warranty:

100% for parts and labor for 2 years, regardless of atmospheric conditions.

8.7.6 Differential/Axle Warranty:

Shall be 36 months/350,000 miles, Parts and Labor.

8.7.7 Hydraulic System Warranty:

Complete Central Hydraulic System and components shall be warranted for 2 years 100% parts and labor. All wiring on system shall be warranted for 5 years 100% parts and labor. Hydraulic pump shall be 3 years 100% parts and labor.

8.7.9 Cab, Cab Structure, Frame Rails and Crossmembers Warranty:

Cab, Cab Structure, Frame Rails and Crossmembers shall be warranty for corrosion for 5 years unlimited mileage 100% parts and labor.

8.7.10 Rear Crane and Bed Body Warranty:

A. 1-year minimum Parts and Labor.

B. 5-year Structural warranty.

State of West Virginia

VENDOR PREFERENCE CERTIFICATE

Certification and application is hereby made for Preference in accordance with *West Virginia Code*, §5A-3-37. (Does not apply to construction contracts). *West Virginia Code*, §5A-3-37, provides an opportunity for qualifying vendors to request (at the time of bid) preference for their residency status. Such preference is an evaluation method only and will be applied only to the cost bid in accordance with the *West Virginia Code*. This certificate for application is to be used to request such preference. The Purchasing Division will make the determination of the Vendor Preference, if applicable.

1. Application is made for 2.5% vendor preference for the reason checked:

Bidder is an individual resident vendor and has resided continuously in West Virginia, or bidder is a partnership, association or corporation resident vendor and has maintained its headquarters or principal place of business continuously in West Virginia, for four (4) years immediately preceding the date of this certification; or,

Bidder is a resident vendor partnership, association, or corporation with at least eighty percent of ownership interest of bidder held by another entity that meets the applicable four year residency requirement; or,

Bidder is a nonresident vendor which has an affiliate or subsidiary which employs a minimum of one hundred state residents and which has maintained its headquarters or principal place of business within West Virginia continuously for the four (4) years immediately preceding the date of this certification; or,

2. Application is made for 2.5% vendor preference for the reason checked:

Bidder is a resident vendor who certifies that, during the life of the contract, on average at least 75% of the employees working on the project being bid are residents of West Virginia who have resided in the state continuously for the two years immediately preceding submission of this bid; or,

3. Application is made for 2.5% vendor preference for the reason checked:

Bidder is a nonresident vendor that employs a minimum of one hundred state residents, or a nonresident vendor which has an affiliate or subsidiary which maintains its headquarters or principal place of business within West Virginia and employs a minimum of one hundred state residents, and for purposes of producing or distributing the commodities or completing the project which is the subject of the bidder's bid and continuously over the entire term of the project, on average at least seventy-five percent of the bidder's employees or the bidder's affiliate's or subsidiary's employees are residents of West Virginia who have resided in the state continuously for the two immediately preceding years and the vendor's bid; or,

4. Application is made for 5% vendor preference for the reason checked:

Bidder meets either the requirement of both subdivisions (1) and (2) or subdivision (1) and (3) as stated above; or,

5. Application is made for 3.5% vendor preference who is a veteran for the reason checked:

Bidder is an individual resident vendor who is a veteran of the United States armed forces, the reserves or the National Guard and has resided in West Virginia continuously for the four years immediately preceding the date on which the bid is submitted; or,

6. Application is made for 3.5% vendor preference who is a veteran for the reason checked:

Bidder is a resident vendor who is a veteran of the United States armed forces, the reserves or the National Guard, if, for purposes of producing or distributing the commodities or completing the project which is the subject of the vendor's bid and continuously over the entire term of the project, on average at least seventy-five percent of the vendor's employees are residents of West Virginia who have resided in the state continuously for the two immediately preceding years.

7. Application is made for preference as a non-resident small, women- and minority-owned business, in accordance with *West Virginia Code* §5A-3-59 and *West Virginia Code of State Rules*.

Bidder has been or expects to be approved prior to contract award by the Purchasing Division as a certified small, women- and minority-owned business.

Bidder understands if the Secretary of Revenue determines that a Bidder receiving preference has failed to continue to meet the requirements for such preference, the Secretary may order the Director of Purchasing to: (a) rescind the contract or purchase order; or (b) assess a penalty against such Bidder in an amount not to exceed 5% of the bid amount and that such penalty will be paid to the contracting agency or deducted from any unpaid balance on the contract or purchase order.

By submission of this certificate, Bidder agrees to disclose any reasonably requested information to the Purchasing Division and authorizes the Department of Revenue to disclose to the Director of Purchasing appropriate information verifying that Bidder has paid the required business taxes, provided that such information does not contain the amounts of taxes paid nor any other information deemed by the Tax Commissioner to be confidential.

Bidder hereby certifies that this certificate is true and accurate in all respects; and that if a contract is issued to Bidder and if anything contained within this certificate changes during the term of the contract, Bidder will notify the Purchasing Division in writing immediately.

Bidder: Worldwide Equipment

Signed: 

Date: 6-14-18

Title: Regional Sales Manager

*Check any combination of preference consideration(s) indicated above, which you are entitled to receive.

STATE OF WEST VIRGINIA
Purchasing Division

PURCHASING AFFIDAVIT

CONSTRUCTION CONTRACTS: Under W. Va. Code § 5-22-1(i), the contracting public entity shall not award a construction contract to any bidder that is known to be in default on any monetary obligation owed to the state or a political subdivision of the state, including, but not limited to, obligations related to payroll taxes, property taxes, sales and use taxes, fire service fees, or other fines or fees.

ALL CONTRACTS: Under W. Va. Code §5A-3-10a, no contract or renewal of any contract may be awarded by the state or any of its political subdivisions to any vendor or prospective vendor when the vendor or prospective vendor or a related party to the vendor or prospective vendor is a debtor and: (1) the debt owed is an amount greater than one thousand dollars in the aggregate; or (2) the debtor is in employer default.

EXCEPTION: The prohibition listed above does not apply where a vendor has contested any tax administered pursuant to chapter eleven of the W. Va. Code, workers' compensation premium, permit fee or environmental fee or assessment and the matter has not become final or where the vendor has entered into a payment plan or agreement and the vendor is not in default of any of the provisions of such plan or agreement.

DEFINITIONS:

"Debt" means any assessment, premium, penalty, fine, tax or other amount of money owed to the state or any of its political subdivisions because of a judgment, fine, permit violation, license assessment, defaulted workers' compensation premium, penalty or other assessment presently delinquent or due and required to be paid to the state or any of its political subdivisions, including any interest or additional penalties accrued thereon.

"Employer default" means having an outstanding balance or liability to the old fund or to the uninsured employers' fund or being in policy default, as defined in W. Va. Code § 23-2c-2, failure to maintain mandatory workers' compensation coverage, or failure to fully meet its obligations as a workers' compensation self-insured employer. An employer is not in employer default if it has entered into a repayment agreement with the Insurance Commissioner and remains in compliance with the obligations under the repayment agreement.

"Related party" means a party, whether an individual, corporation, partnership, association, limited liability company or any other form or business association or other entity whatsoever, related to any vendor by blood, marriage, ownership or contract through which the party has a relationship of ownership or other interest with the vendor so that the party will actually or by effect receive or control a portion of the benefit, profit or other consideration from performance of a vendor contract with the party receiving an amount that meets or exceeds five percent of the total contract amount.

AFFIRMATION: By signing this form, the vendor's authorized signer affirms and acknowledges under penalty of law for false swearing (W. Va. Code §61-5-3) that: (1) for construction contracts, the vendor is not in default on any monetary obligation owed to the state or a political subdivision of the state, and (2) for all other contracts, that neither vendor nor any related party owe a debt as defined above and that neither vendor nor any related party are in employer default as defined above, unless the debt or employer default is permitted under the exception above.

WITNESS THE FOLLOWING SIGNATURE:

Vendor's Name: Worldwide Equipment

Authorized Signature: [Signature] Date: 6-14-18

State of West Virginia

County of Kanawha, to-wit:

Taken, subscribed, and sworn to before me this 14th day of June, 2018

My Commission expires October 23, 2020.

AFFIX SEAL HERE

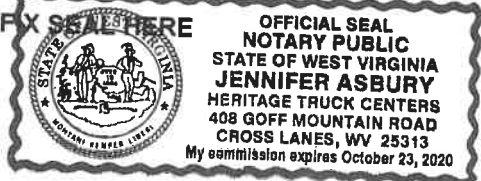

NOTARY PUBLIC

[Signature]

Purchasing Affidavit (Revised 01/19/2018)



Purchasing Division
 2019 Washington Street East
 Post Office Box 50130
 Charleston, WV 25305-0130

State of West Virginia
 Request for Quotation
 13 - Equipment

Proc Folder: 445837

Doc Description: ADDENDUM_1: (Class 332) TANDEM AXLE TRUCK W/ 23-TON CRANE

Proc Type: Central Master Agreement

Date Issued	Solicitation Closes	Solicitation No	Version
2018-05-30	2018-06-07 13:30:00	CRFQ 0803 DOT1800000097	2

BID RECEIVING LOCATION

BID CLERK
 DEPARTMENT OF ADMINISTRATION
 PURCHASING DIVISION
 2019 WASHINGTON ST E
 CHARLESTON WV 25305
 US

VENDOR

Vendor Name, Address and Telephone Number:

Worldwide Equipment
 408 New Goff Mountain Rd
 Cross Lanes, WV 25313
 304-345-2490

FOR INFORMATION CONTACT THE BUYER

Mark A Atkins
 (304) 558-2307
 mark.a.atkins@wv.gov

Signature X

FEIN # 45-1024981

DATE

6-14-18

All offers subject to all terms and conditions contained in this solicitation

ADDITIONAL INFORMATION:

ADDENDUM 1 is issued for the following:

1. To move the bid opening date from 05/31/2018 to 06/07/2018 at 1:30pm EST.
2. To publish the Agency responses to the questions submitted by Vendors during the Technical Questioning period.
3. To publish the mandatory Pre-Bid attendance sheets.

No other changes made.

The West Virginia Purchasing Division is soliciting bids on behalf of the West Virginia Division of Highways, Department of Transportation to establish an open-end contract for a 60,000 GVWR Tandem Axle Straight Truck with 23-ton behind cab Crane with Outriggers per attached documents.

MANDATORY PRE-BID MEETING:

WV Division of Highways
Equipment Division
83 Brushy Fork Rd Crossing
Buckhannon, WV 26201

Time: 10:00am EDT
Date: May 17, 2018

INVOICE TO	SHIP TO
DIVISION OF HIGHWAYS EQUIPMENT DIVISION RT 33 83 BRUSHY ROAD CROSSING, PO BOX 610 BUCKHANNON WV26201 US	DIVISION OF HIGHWAYS EQUIPMENT DIVISION 83 BRUSHY FORK RD CROSSING BUCKHANNON WV 26201 US

Line	Comm Ln Desc	Qty	Unit Issue	Unit Price	Total Price
1	60,000 GVWR TRUCK WITH 23-TON TRUCK CRANE	15.00000	EA		

Comm Code	Manufacturer	Specification	Model #
25101933			

Extended Description :

60,000 GVWR TRUCK WITH 23-TON TRUCK CRANE:

Year:

Make:

Model:

SCHEDULE OF EVENTS

Line	Event	Event Date
1	Mandatory PreBid Meeting @ 10:00am EDT:	2018-05-17
2	Technical Questions due by 2:00pm EDT:	2018-05-22

SOLICITATION NUMBER: CRFQ 0803 DOT1800000097
Addendum Number: 1

The purpose of this addendum is to modify the solicitation identified as CRFQ 0803 DOT1800000097 ("Solicitation") to reflect the change(s) identified and described below.

Applicable Addendum Category:

- Modify bid opening date and time
- Modify specifications of product or service being sought
- Attachment of vendor questions and responses
- Attachment of pre-bid sign-in sheet
- Correction of error
- Other

Description of Modification to Solicitation:

1. To move the bid opening date from 05/31/2018 to 06/07/2018 at 1:30pm EST.
2. To publish the Agency responses to the questions submitted by Vendors during the Technical Questioning period.
3. To publish the mandatory Pre-Bid attendance sheets.

No other changes made.

Additional Documentation: Documentation related to this Addendum (if any) has been included herewith as Attachment A and is specifically incorporated herein by reference.

Terms and Conditions:

1. All provisions of the Solicitation and other addenda not modified herein shall remain in full force and effect.
 2. Vendor should acknowledge receipt of all addenda issued for this Solicitation by completing an Addendum Acknowledgment, a copy of which is included herewith. Failure to acknowledge addenda may result in bid disqualification. The addendum acknowledgement should be submitted with the bid to expedite document processing.
-

ATTACHMENT_A

ADDENDUM_1

CRFQ 0803 DOT1800000097

(332 Class) 60,000 GVWR Tandem Axle Truck W/23-Ton Crane

THE ORIGINAL LANGUAGE IN CONTRACT WILL BE LISTED FIRST WITH QUESTION AND ANSWER TO FOLLOW BELOW.

1. 3.1.1 Cab and Chassis

Question: We suggest the cab and chassis have a set forward axle design and a 264" CT dimension for best legal weight distribution.

Answer: We will accept.

2. 3.1.2.3 R.B.M: Minimum 2,820,000 Ins./Lb. per rail. An integral frame and frame extension is mandatory.

Question # 1: How long does it need to be, the integral frame extension?

Question # 2 Since the hydraulic pump will be powered by a transmission driven PTO, a front frame extension is not required for our crane.

Answer # 1: You need to consult with crane manufacturer to see if frame ext. is needed to accommodate front outrigger (extensions can be deleted if not required)

Answer # 2: Front frame and bumper shall accept front mounted outrigger for crane (extension can be deleted if not required).

3. 3.1.5.2 Right side and left side cab mirrors: Cab mirrors shall be west coast type 7 inches wide minimum x 16 inches high minimum, power adjustable with fore and after breakaway arms. 8 inches minimum convex spot mirror. Both mirrors must be heated type with all arms, hardware and fasteners corrosion resistant.

Question: Will the state allow 7.55 x 14.1 previously approved?

Answer: Yes, will accept.

4. **3.1.9.2** Single aluminum 110-gallon minimum fuel tank, shall be mounted left side, under cab, frame-mounted with stainless steel mounting straps.

Question: Will the state consider 100 gal as minimum?

Answer: Yes, will accept.

5. **3.1.10.3** Shall have a transmission shift pad/shift selector, with oil life monitor; filter life monitor and transmission health monitor, lighted and dash or console mounted in cab.

Question: Will the state accept stalk shifter on steering column still maintaining oil life and transmission health monitor, "previously approved"

Answer: Yes, will accept.

6. **3.1.10.4.1** All cooler hard lines must be corrosion resistant.

Question: "States that all cooler hard lines must be corrosion resistant." The lines on the Freightliner transmission cooler is rubber with zinc coated steel ends. Would this be acceptable?

Answer: Yes, will accept.

7. **3.1.10.5** Transmission (TCM) Transmission control module shall be located in cab.

Question: The Freightliner TCM is located under the cab in a weatherproof housing. Is this acceptable?

Answer: Yes, will accept.

8. **3.1.12.1** Shall be single reduction with a power divider lockout, dash controlled, minimum rating of 40,000 lbs.

Question: Would like to clarify if they are wanting locking differential on both tandem axles-or just the front tandem or the rear tandem.

Answer: Will change to read **3.1.12.1: Shall be single reduction with power divider lockout front tandem only, dash controlled, minimum rating of 40,000 lbs.**

9. **3.1.22 Power Take Off and Hydraulics**

Question: We suggest that the PTO and Hydraulics paragraph be part of the crane description.

Answer: Line Items # 3.1.22.1 thru 3.1.22.7 will delete and add under #3.1.22.1 PTO and Hydraulics with cooler system shall accommodate crane manufacturers standard hydraulic system with all safety functions

10. **3.1.23 Hydraulic Pump**

Question: We suggest that the Hydraulic pump section be part of the crane description and changed as follows:

3.1.23.3 A triple fixed displacement gear pump to provide 32 GPM up to 3000 PSI, for the winch circuit, 24 GPM up to 3300 PSI for the boom circuit, and 16 GPM up to 1500 PSI for the outrigger and swing circuit.

Answer: Will delete 3.1.23 Hydraulic pump section, refer to new line item # 3.1.22.1 PTO and Hydraulics with cooler system shall accommodate crane manufacturers standard hydraulic system with all safety functions.

11. **3.1.23.8** The pump must have internal bleed down compensator option.

Question: A compensation option is not used with a gear pump, and we request this part of the spec be deleted.

Answer: 3.1.23.8 will be deleted.

12. **3.1.23.9** Compensator shall have 2 ports to choose from for the load sense line for ease of installation.

Question: A compensation option is not used with a gear pump, and we request this part of the spec be deleted.

Answer: 3.1.23.9 will be deleted.

13. 3.1.26.9 Shall be two right and two left side stainless steel mounted toolboxes for storage minimum size of 36 inches wide x 16 inches tall x 16 inches deep or equal.

Question: Aluminum tool boxes in lieu of stainless steel will reduce weight and increase payload.

Answer: Will accept Aluminum or Stainless.

14. 6.1 Delivery Time: Vendor shall deliver standard orders within 270 calendar days after orders are received. Vendor shall ship all orders in accordance with the above schedule and shall not hold orders until a minimum delivery quantity is met. A completed pilot model for inspection must be provided within 175 calendar days after receipt of the purchase agreement by the successful vendor.

Question: We suggest delivery time for the pilot unit be increased to 330 days and to 360 days for the standard order.

Answer: Will change to 330 calendar days on pilot, 350 calendar days on standard orders.

**PRE-BID CONFERENCE
SIGN IN SHEET**

Request for Quotation Number: CRFQ 0803 DOT180000097 Date: 5/17/19

Project Description: 60,000 GVWR TANDEM AXLE TRUCK W/23-TON CRANE

PLEASE PRINT LEGIBLY. THIS INFORMATION IS ESSENTIAL TO CONTACT THE ATTENDEES IN A TIMELY MANNER. FAILURE TO DO SO MAY RESULT IN DELAYS IN YOUR COMPANY GETTING IMPORTANT BID INFORMATION.

Firm Name: Worldwide 294.0mest
 Firm Address: 407 New Golf Maintenance Road
Cross Lanes WV 25313
 Representative Attending: Matt Cochran
 Phone Number: 304-208-2542
 Fax Number: 304-759-9807
 Email Address: Matt.cochran@thetruckpeople.com

Firm Name: WEST VIRGINIA TRACTOR CO
 Firm Address: P.O. BOX 473
CHARLESTON, WV 25312
 Representative Attending: GARY GARDY
 Phone Number: 304-346-5301
 Fax Number: 304-346-5305
 Email Address: wvtractor@msn.com

Firm Name: ~~Jack Cochran~~
 Firm Address:
 Representative Attending:
 Phone Number:
 Fax Number:
 Email Address:

Firm Name: Matheny Motor Truck Co
 Firm Address: 50 MATHENY LANE
MINERAL WELLS WV 26150
 Representative Attending: Jack Cummings
 Phone Number: 304-769-5860 x 3601
 Fax Number: 304-769-5866
 Email Address: jcummings@mathenymotors.com

Firm Name: CLARKSBURG MACK
 Firm Address: 1481 SHINNSTON PIKE
CLARKSBURG, WV 26301
JERRY E. CLARKSBURG MACK, COM
 Representative Attending: Jerry ARMEN TROUT
 Phone Number: 304-203-5007
 Fax Number: 304-422-2908
 Email Address: JERRY@CLARKSBURGMACK.COM

Firm Name:
 Firm Address:
 Representative Attending:
 Phone Number:
 Fax Number:
 Email Address:

PRE-BID CONFERENCE
SIGN IN SHEET

Request for Quotation Number: CE FQ 0803 DOT1800000097 Date: 5/17/18

Project Description: 60,000 GVWR TANDEM AXLE TRUCK W/23-TON CRANE

PLEASE PRINT LEGIBLY. THIS INFORMATION IS ESSENTIAL TO CONTACT THE ATTENDEES IN A TIMELY MANNER. FAILURE TO DO SO MAY RESULT IN DELAYS IN YOUR COMPANY GETTING IMPORTANT BID INFORMATION.

Firm Name:
Firm Address: Pam Hall
WV DOT

Representative Attending:
Phone Number:
Fax Number:
Email Address:

Firm Name:
Firm Address: MARCIA Lee
DOH

Representative Attending:
Phone Number:
Fax Number:
Email Address:

Firm Name:
Firm Address: JEFF PIFER
DOH

Representative Attending:
Phone Number:
Fax Number:
Email Address:

Firm Name:
Firm Address: Angie Moorman
DOH

Representative Attending:
Phone Number:
Fax Number:
Email Address:

Firm Name:
Firm Address: Travis Ray
WVDOH

Representative Attending:
Phone Number:
Fax Number:
Email Address:

Firm Name:
Firm Address:

Representative Attending:
Phone Number:
Fax Number:
Email Address:



WORLDWIDE
EQUIPMENT

THE TRUCK PEOPLE

408 New Golf Mountain Road
Cross Lanes WV 25313

P: (304)345-2490
C: (304)208-2542
F: (304)759-9807
matt.cochran@thetruckpeople.com

Matt Cochran
Regional Sales Manager

twitter.com/truckpeople
facebook.com/theTruckPeople

WWW.THETRUCKPEOPLE.COM

MATHENY
TRUCK CENTER

4125 1st Avenue
Nitro, WV 25143

Jack Cummings

Commercial Sales Consultant
jcummings@mathenymotors.com
304.769.5860 x3601 TEX
877.986.4876 TOLL FREE
304.539.3817 CELL
www.mathenymotors.com



Jerry V. Armentrout

Sales Manager
jerry@clarksburgmack.com



Clarksburg Mack Sales & Service, Inc.
1481 Shinnston Pike
Clarksburg, West Virginia 26301
USA

MAIN +800 288 7661
MOBILE +304 203 5007
FAX +304 622 2908

clarksburgmack.com

OFFICE (304) 346-5301
(800) 640-8245



**WEST VIRGINIA
TRACTOR COMPANY**
CONSTRUCTION, MINING, MUNICIPAL & INDUSTRIAL EQUIPMENT

www.wvtractor.com

GARY W. GRADY
PRESIDENT
Cell (304) 548-6068

P. O. BOX 473
214 VIRGINIA ST. W.
CHAS., WV 25322/25302

wvtractor@msn.com



Purchasing Division
 2019 Washington Street East
 Post Office Box 50130
 Charleston, WV 25305-0130

State of West Virginia
 Request for Quotation
 13 - Equipment

Proc Folder: 445837

Doc Description: ADDENDUM_2: (Class 332) TANDEM AXLE TRUCK W/ 23-TON CRANE

Proc Type: Central Master Agreement

Date Issued	Solicitation Closes	Solicitation No	Version
2018-06-06	2018-06-14 13:30:00	CRFQ 0803 DOT1800000097	3

BID RECEIVING LOCATION

BID CLERK
 DEPARTMENT OF ADMINISTRATION
 PURCHASING DIVISION
 2019 WASHINGTON ST E
 CHARLESTON WV 25305
 US

VENDOR

Vendor Name, Address and Telephone Number:

Worldwide Equipment
 408 New Goff Mountain Rd.
 Cross Lanes, WV 25313
 304-345-2490

FOR INFORMATION CONTACT THE BUYER

Mark A Atkins
 (304) 558-2307
 mark.a.atkins@wv.gov

Signature X

FEIN # 45-1024981

DATE

6/14/18

All offers subject to all terms and conditions contained in this solicitation

ADDITIONAL INFORMATION:

ADDENDUM 2 Is issued for the following:

1. To move the bid opening date from 06/07/2018 to 06/14/2018 at 1:30pm EST.

No other changes made.

The West Virginia Purchasing Division is soliciting bids on behalf of the West Virginia Division of Highways, Department of Transportation to establish an open-end contract for a 60,000 GVWR Tandem Axle Straight Truck with 23-ton behind cab Crane with Outriggers per attached documents.

MANDATORY PRE-BID MEETING:

WV Division of Highways
Equipment Division
83 Brushy Fork Rd Crossing
Buckhannon, WV 26201

Time: 10:00am EDT
Date: May 17, 2018

INVOICE TO	SHIP TO
DIVISION OF HIGHWAYS EQUIPMENT DIVISION RT 33 83 BRUSHY ROAD CROSSING, PO BOX 610 BUCKHANNON WV26201 US	DIVISION OF HIGHWAYS EQUIPMENT DIVISION 83 BRUSHY FORK RD CROSSING BUCKHANNON WV 26201 US

Line	Comm Ln Desc	Qty	Unit Issue	Unit Price	Total Price
1	60,000 GVWR TRUCK WITH 23-TON TRUCK CRANE	15.00000	EA		

Comm Code	Manufacturer	Specification	Model #
25101933			

Extended Description :

60,000 GVWR TRUCK WITH 23-TON TRUCK CRANE:

Year:

Make:

Model:

SCHEDULE OF EVENTS

Line	Event	Event Date
1	Mandatory PreBid Meeting @ 10:00am EDT:	2018-05-17
2	Technical Questions due by 2:00pm EDT:	2018-05-22

SOLICITATION NUMBER: CRFQ 0803 DOT1800000097
Addendum Number: 2

The purpose of this addendum is to modify the solicitation identified as CRFQ 0803 DOT1800000097 (“Solicitation”) to reflect the change(s) identified and described below.

Applicable Addendum Category:

- Modify bid opening date and time
- Modify specifications of product or service being sought
- Attachment of vendor questions and responses
- Attachment of pre-bid sign-in sheet
- Correction of error
- Other

Description of Modification to Solicitation:

1. To move the bid opening date from 06/07/2018 to 06/14/2018 at 1:30pm EST.

No other changes made.

Additional Documentation: Documentation related to this Addendum (if any) has been included herewith as Attachment A and is specifically incorporated herein by reference.

Terms and Conditions:

1. All provisions of the Solicitation and other addenda not modified herein shall remain in full force and effect.
2. Vendor should acknowledge receipt of all addenda issued for this Solicitation by completing an Addendum Acknowledgment, a copy of which is included herewith. Failure to acknowledge addenda may result in bid disqualification. The addendum acknowledgement should be submitted with the bid to expedite document processing.

ADDENDUM ACKNOWLEDGEMENT FORM
SOLICITATION NO.: CRFQ 0803 DOT180000097

Instructions: Please acknowledge receipt of all addenda issued with this solicitation by completing this addendum acknowledgment form. Check the box next to each addendum received and sign below. Failure to acknowledge addenda may result in bid disqualification.

Acknowledgment: I hereby acknowledge receipt of the following addenda and have made the necessary revisions to my proposal, plans and/or specification, etc.

Addendum Numbers Received:

(Check the box next to each addendum received)

- | | |
|--|--|
| <input checked="" type="checkbox"/> Addendum No. 1 | <input type="checkbox"/> Addendum No. 6 |
| <input checked="" type="checkbox"/> Addendum No. 2 | <input type="checkbox"/> Addendum No. 7 |
| <input type="checkbox"/> Addendum No. 3 | <input type="checkbox"/> Addendum No. 8 |
| <input type="checkbox"/> Addendum No. 4 | <input type="checkbox"/> Addendum No. 9 |
| <input type="checkbox"/> Addendum No. 5 | <input type="checkbox"/> Addendum No. 10 |

I understand that failure to confirm the receipt of addenda may be cause for rejection of this bid. I further understand that that any verbal representation made or assumed to be made during any oral discussion held between Vendor's representatives and any state personnel is not binding. Only the information issued in writing and added to the specifications by an official addendum is binding.

Worldwide Equipment

Company



Authorized Signature

6-14-18

Date

NOTE: This addendum acknowledgment should be submitted with the bid to expedite document processing.

Prepared For:
 WV Dept. of Highways
 Travis Ray
 P. O. Box 610
 Buckhannon, WV 26201-
 (304)472 - 1750
 Reference ID: N/A

Presented By:
 WORLDWIDE EQ-HERITAGE
 Matt Cochran
 1 JAIN DRIVE
 CROSS LANES WV 25313
 304-776-5600

Thank you for the opportunity to provide you with the following quotation on a new International truck. I am sure the following detailed specification will meet your operational requirements, and I look forward to serving your business needs.

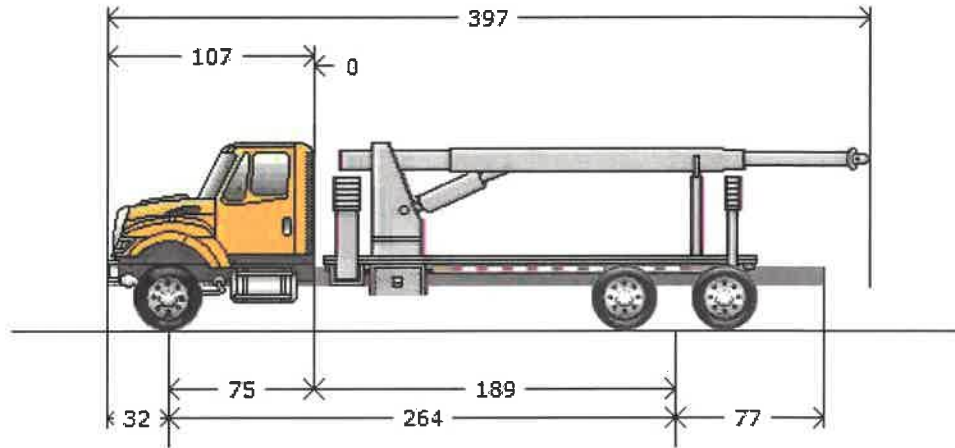

Model Profile
2019 HV507 SFA (HV507)

AXLE CONFIG:	6X4
APPLICATION:	Mobile Aerial Crane
MISSION:	Requested GVWR: 60000. Calc. GVWR: 60000 Calc. Start / Grade Ability: 19.12% / 2.23% @ 55 MPH Calc. Geared Speed: 73.7 MPH
DIMENSION:	Wheelbase: 264.00, CA: 189.00, Axle to Frame: 77.00
ENGINE, DIESEL:	{Cummins L9 370} EPA 2017, 370HP @ 2000 RPM, 1250 lb-ft Torque @ 1400 RPM, 2100 RPM Governed Speed, 370 Peak HP (Max)
TRANSMISSION, AUTOMATIC:	{Allison 3000 RDS} 5th Generation Controls, Close Ratio, 6-Speed with Double Overdrive, with PTO Provision, Less Retarder, Includes Oil Level Sensor, On/Off Highway
CLUTCH:	Omit Item (Clutch & Control)
AXLE, FRONT NON-DRIVING:	{Meritor MFS-20-133A} Wide Track, I-Beam Type, 20,000-lb Capacity
AXLE, REAR, TANDEM:	{Meritor MT-40-14X-4DFR} Single Reduction, 40,000-lb Capacity, w/.433"(11mm) Wall Housing Thickness, R Wheel Ends Gear Ratio: 5.29
CAB:	Conventional
TIRE, FRONT:	(2) 315/80R22.5 Load Range L G289 WHA (GOODYEAR), 484 rev/mile, 68 MPH, All-Position
TIRE, REAR:	(8) 11R22.5 Load Range G G622 RSD (GOODYEAR), 497 rev/mile, 75 MPH, Drive
SUSPENSION, REAR, TANDEM:	{International} 4-Spring Type, Multileaf, 52" Axle Spacing; 40,000-lb Capacity
PAINT:	Cab schematic 100WK Location 1: 4017, Dark Safety Yellow (Prem) Chassis schematic N/A

Description

Base Chassis, Model HV507 SFA with 264.00 Wheelbase, 189.00 CA, and 77.00 Axle to Frame.

TOW HOOK, FRONT (2) Frame Mounted

AXLE CONFIGURATION {Navistar} 6x4

Notes

: Pricing may change if axle configuration is changed.

FRAME RAILS Heat Treated Alloy Steel (125,000 PSI Yield); 11.25" x 4.00" x 0.500" (285.75mm x 101.6mm x 12.7mm); 480.8" (12212mm) Maximum OAL

BUMPER, FRONT Steel, Swept Back

FRAME EXTENSION, FRONT Integral; 27" In Front of Grille

WHEELBASE RANGE 228" (580cm) Through and Including 270" (685cm)

AXLE, FRONT NON-DRIVING {Meritor MFS-20-133A} Wide Track, I-Beam Type, 20,000-lb Capacity

SUSPENSION, FRONT, SPRING Parabolic, Taper Leaf; 20,000-lb Capacity; with Shock Absorbers

BRAKE SYSTEM, AIR Dual System for Straight Truck Applications

BRAKES, FRONT, AIR CAM 16.5" x 6", Includes 24 SqIn Long Stroke Brake Chambers

TRAILER CONNECTIONS Four-Wheel, with Hand Control Valve and Tractor Protection Valve, for Straight Truck

DRAIN VALVE {Berg} with Pull Chain, for Air Tank

AIR BRAKE ABS {Bendix AntiLock Brake System} Full Vehicle Wheel Control System (4-Channel)

AIR DRYER {Wabco System Saver 1200} with Heater

BRAKE CHAMBERS, REAR AXLE {Bendix EverSure} 30/30 Spring Brake

BRAKE CHAMBERS, FRONT AXLE {Bendix} 24 SqIn

SLACK ADJUSTERS, FRONT {Haldex} Automatic

SLACK ADJUSTERS, REAR {Haldex} Automatic

BRAKE ATTACHMENT Stainless Steel Slack Adjuster Pins/Cotter Pins on Front and Rear

BRAKES, REAR, AIR CAM S-Cam; 16.5" x 7.0"; Includes 30/30 Sq.In. Long Stroke Brake Chamber and Spring Actuated Parking Brake

AIR COMPRESSOR {Cummins} 18.7 CFM Capacity

AIR DRYER LOCATION Mounted Inside Right Rail, Approx. 35" Back of Cab

AIR TANK Painted Aluminum, with Straight Thread O-Ring Ports

AIR TANK LOCATION (2) : One Mounted Under Each Frame Rail, Front of Rear Suspension, Parallel to Rail

STEERING COLUMN Stationary

STEERING WHEEL 4-Spoke; 18" Dia., Black

STEERING GEAR (2) {Sheppard M100/M80} Dual Power

AFTERTREATMENT COVER Aluminum

EXHAUST SYSTEM Single Horizontal Aftertreatment Device, Frame Mounted Right Side Under Cab; for Single Vertical Tail Pipe, Frame Mounted Right Side Back of Cab

ENGINE COMPRESSION BRAKE {Jacobs} for Cummins ISL/L9 Engines; with Selector Switch and On/Off Switch

TAIL PIPE (1) Turnback Type, Non-Bright, for Single Exhaust

Description

EXHAUST HEIGHT 8' 10"

MUFFLER/TAIL PIPE GUARD (1) Non-Bright Aluminum

ELECTRICAL SYSTEM 12-Volt, Standard Equipment

ALTERNATOR {Leece-Neville AVI160P2013} Brush Type; 12 Volt 160 Amp. Capacity, Pad Mount, with Remote Sense

BODY BUILDER WIRING Back of Standard or Sleeper Cab at Left Frame or Under Extended or Crew Cab at Left Frame; Includes Sealed Connectors for Tail/Amber Turn/Marker/ Backup/Accessory Power/Ground and Sealed Connector for Stop/Turn

ELECTRIC TRAILER BRAKE/LIGHTS Accommodation Package to Rear of Frame; for Combined Trailer Stop, Tail, Turn, Marker Light Circuits; Includes Electric Trailer Brake Accommodation Package with Cab Connections for Mounting Customer Installed Electric Brake Unit, Less Trailer Socket

BATTERY SYSTEM {International} Maintenance-Free, (3) 12-Volt 1950CCA Total

RADIO AM/FM/WB/Clock/Bluetooth/USB Input/3.5MM Auxiliary Input, MP3, Apple Device Play & Control, Bluetooth for Phone & Music

SPEAKERS (2) 5.25" Dual Cone Mounted in Both B-Pillars

CB RADIO Accommodation Package; Header Mounted; Feeds From Accessory Side of Ignition Switch; Includes Power Source and One (1) Antenna, Antenna Base with Wiring on Left Side Mirror

TRAILER AUXILIARY FEED CIRCUIT for Electric Trailer Brake Accommodation/Air Trailer ABS; with 30 Amp Fuse and Relay, Controlled by Ignition Switch

HORN, ELECTRIC Disc Style

BATTERY BOX Steel, with Fiberglass Cover, Mounted 53" Back of Cab, Left Side Perpendicular to Frame Rail

RUNNING LIGHT (2) Daytime

CLEARANCE/MARKER LIGHTS (5) {Truck Lite} Amber LED Lights, Flush Mounted on Cab or Sunshade

STARTING MOTOR {Delco Remy 38MT Type 300} 12 Volt; less Thermal Over-Crank Protection

INDICATOR, LOW COOLANT LEVEL with Audible Alarm

CIRCUIT BREAKERS Manual-Reset (Main Panel) SAE Type III with Trip Indicators, Replaces All Fuses

TURN SIGNALS, FRONT Includes LED Side Turn Lights Mounted on Fender

HORN, AIR Black, Single Trumpet, with Lanyard Pull Cord

LOGOS EXTERIOR Badges

LOGOS EXTERIOR, ENGINE Badges

GRILLE Stationary, Chrome

BUG SCREEN Mounted Behind Grille

FRONT END Tilting, Fiberglass, with Three Piece Construction; for WorkStar/HV

PAINT SCHEMATIC, PT-1 Single Color, Design 100

Includes

: PAINT SCHEMATIC ID LETTERS "WK"

PAINT TYPE Base Coat/Clear Coat, 1-2 Tone

PAINT CLASS Premium Color

SAFETY TRIANGLES

CLUTCH Omit Item (Clutch & Control)

ANTI-FREEZE Red, Extended Life Coolant; To -40 Degrees F/ -40 Degrees C, Freeze Protection

Description

BLOCK HEATER, ENGINE 120V/1000W, for Cummins ISB/B6.7/ISL/L9 Engines

ENGINE, DIESEL {Cummins L9 370} EPA 2017, 370HP @ 2000 RPM, 1250 lb-ft Torque @ 1400 RPM, 2100 RPM Governed Speed, 370 Peak HP (Max)

FAN DRIVE {Horton Drivemaster} Direct Drive Type, Two Speed with Residual Torque Device for Disengaged Fan Speed

RADIATOR Cross Flow, Series System; 1228 SqIn Aluminum Radiator Core with Internal Water to Oil Transmission Cooler and 1167 In Charge Air Cooler

AIR CLEANER Dual Element, with Integral Pre Cleaner

FEDERAL EMISSIONS {Cummins L9} EPA, OBD and GHG Certified for Calendar Year 2018

THROTTLE, HAND CONTROL Engine Speed Control; Electronic, Stationary, Variable Speed; Mounted on Steering Wheel

EMISSION COMPLIANCE Federal, Does Not Comply with California Clean Air Idle Regulations

ENGINE CONTROL, REMOTE MOUNTED Provision for; Includes Wiring for Body Builder Installation of PTO Controls and Starter Lockout; with Ignition Switch Control for Cummins B6.7 and L9 Engines

TRANSMISSION, AUTOMATIC {Allison 3000 RDS} 5th Generation Controls, Close Ratio, 6-Speed with Double Overdrive, with PTO Provision, Less Retarder, Includes Oil Level Sensor, On/Off Highway

TRANSMISSION SHIFT CONTROL for Column Mounted Stalk Shifter

TRANSMISSION DIPSTICK Relocated to Right Side of Transmission

TRANSMISSION COOLER HOSES Stainless Steel

TRANSMISSION OIL Synthetic; 29 thru 42 Pints

ALLISON SPARE INPUT/OUTPUT for Rugged Duty Series (RDS); General Purpose Trucks, Construction

TRANSMISSION TCM LOCATION Located Inside Cab

SHIFT CONTROL PARAMETERS Allison 3000 or 4000 Series Transmissions, 5th Generation Controls, Performance Programming

PTO LOCATION Dual, Left and Right Side of Transmission

AXLE, REAR, TANDEM {Meritor MT-40-14X-4DFR} Single Reduction, 40,000-lb Capacity, w/.433"(11mm) Wall Housing Thickness, R Wheel Ends . Gear Ratio: 5.29

SUSPENSION, REAR, TANDEM {International} 4-Spring Type, Multileaf, 52" Axle Spacing; 40,000-lb Capacity

DEF TANK 9.5 U.S. Gal. 35.9L Capacity, Frame Mounted Outside Left Rail, Under Cab

LOCATION FUEL/WATER SEPARATOR Mounted Outside Left Rail, 41" Back of Cab

FUEL/WATER SEPARATOR {Racor 400 Series,} with Primer Pump, Includes Water-in-Fuel Sensor

FUEL TANK Top Draw, Non-Polished Aluminum, 26" Dia, 100 US Gal (379L), Mounted Left Side, Under Cab

CAB Conventional

AIR CONDITIONER with Integral Heater & Defroster

GAUGE CLUSTER Premium Level; English with English Speedometer and Tachometer, for Air Brake Chassis, Includes Engine Coolant Temperature, Primary and Secondary Air Pressure, Fuel and DEF Gauges, Oil Pressure Gauge, Includes 5 Inch LCD Color Display

IP CLUSTER DISPLAY On Board Diagnostics Display of Fault Codes in Gauge Cluster

VIRTUAL GA, OIL TEMP, AUTO XMSN for Allison Transmission, Requires Premium Cluster

SEAT, PASSENGER {National} Air-Suspension, High Back with Integral Headrest, Mordura Cloth, Isolated, 1 Chamber Lumbar, 2 Position Front Cushion Adjust, -3 to +14 Degree Back Angle Adjustment

Description

SEAT, DRIVER {National 2000} Air Suspension, High Back with Integral Headrest, Mordura Cloth, Isolated, with 2 Position Front Cushion Adjustment, -3 to +14 Degree Seat Back Adjustment, Single Chamber Air Lumbar Support

MIRRORS (2) Power Adjust, Thermostatically Controlled Heated Heads, LED Clearance Lights, Bright Finish Heads and Arms, Black Brackets, 7.55" x 14.1" Flat Glass, 7.48" x 6.77" Convex Glass Both Sides

MIRROR, CONVEX, LOOK DOWN Right Side, Bright, 6" x 10 1/4"

CAB INTERIOR TRIM Classic, for Day Cab

WINDSHIELD Heated, Single Piece

CAB SOUND INSULATION Includes Dash Insulator and Engine Cover Insulator

WINDOW, POWER (2) and Power Door Locks, Left and Right Doors, Includes Express Down Feature

CAB REAR SUSPENSION Air Bag Type

INSTRUMENT PANEL Flat Panel

CUTOUT, INSTRUMENT PANEL for Customer Installed Auxiliary Switches

WINDSHIELD WIPER BLADES Snow Type

ACCESS, CAB {Bustin} Driver & Passenger Sides, Two Aluminum, Self-Cleaning Steps (Bustin) Per Door, For Use with Regular & Extended Cabs

WHEELS, FRONT {Accuride 41730} DISC; 22.5x9.00 Rims, Standard Polish Aluminum, 10-Stud, 285.75mm BC, Hub-Piloted, Flanged Nut, with Steel Hubs

WHEELS, REAR DUAL DISC; 22.5x8.25 Rims, Non-Polished Aluminum, 10-Stud 285.75mm BC, Hub-Piloted, Flanged Nut, with Steel Hubs

COATING IDENTITY, REAR WHEELS {Accuride Accu-shield} Aluminum Disc Rear Wheels, with Vendor Applied Clear Coat; Not for Super Single Wide Base

COATING IDENTITY, FRONT WHEELS {Accuride Accu-shield} Disc Front Wheels; Aluminum, with Vendor Applied Clear Coat Not for Wide Base

WHEEL GUARDS, FRONT {Accuride} for Metric Hub Piloted Wheels with Flanged Mounting Nuts Mounted Between Hub and Wheel

BDY INTG, REMOTE POWER MODULE Mounted Inside Cab behind Driver Seat; Up to 6 Outputs & 6 Inputs, Max. 20 amp. per Channel, Max. 80 amp Total (Includes 1 Switch Pack with Latched Switches)

(8) TIRE, REAR 11R22.5 Load Range G G622 RSD (GOODYEAR), 497 rev/mile, 75 MPH, Drive

(2) TIRE, FRONT 315/80R22.5 Load Range L G289 WHA (GOODYEAR), 484 rev/mile, 68 MPH, All-Position

Services Section:

WARRANTY Standard for HV507, HV50B, HV607 Models, Effective with Vehicles Built July 1, 2017 or Later, CTS-2025A

SRV CONTRACT, EXT COOLING SYS {Navistar} To 24-Month/100,000 Miles (160,000 km)

SRV CONTRACT, EXT CMMS ENGINE {Cummins} To 60-Month/150,000 Miles (240,000 km), Extended Cummins L9 Engine Coverage, Protection Plan 1

SRV CONTRACT, EXT CMMS AFTR {Cummins} To 60-Month/150,000 Miles (240,000 km), Extended Cummins L9 Aftertreatment Coverage, for Use when Protection Plan 1 of Equal or Greater Duration is Purchased (Truck Application Only)



June 6, 2018

Our 89th Year
Ship To:

WEST VIRGINIA TRACTOR COMPANY
214 VIRGINIA ST W
CHARLESTON, WV 25302
US
Attn:

Bill To:

WEST VIRGINIA TRACTOR COMPANY
214 VIRGINIA ST W
CHARLESTON, WV 25302
United States

Phone: 304-346-5301
Email:

Altec Quotation Number: 436495 - 1

Account Manager: Keaton E Gleason
Technical Sales Rep: Aric Mason King

Item	Description	Qty	Price
------	-------------	-----	-------

1.	Altec's AC23-95 Hydraulic Telescopic Crane built in accordance to Altec's standard	1	
----	--	---	--

specifications and includes the following features:

- A. Maximum Lifting Capacity: 23.5 ton (21.3 metric ton)
- B. Boom: 95 foot (29 m), 4-Section Proportional
- C. Sheave Height: 105 foot (32 m) on base boom
- D. Altec LMAP (Load Moment & Area Protection) System: Hirschmann system that includes Rated Capacity Limiter and Working Area Definition Audible Alarm Set-Points. Includes boom angle, length and rotational position.
- E. Winch: Single speed with burst of speed, 12,000 pound (5,443 kg) line pull on bare drum, mounted at base of boom (unless otherwise stated below in options)
- F. Lower Winch Control: Located at hook stowage point for ease of unit setup
- G. Winch Drum Rotation Indicator: Provides tactile and visual indication to operator of which motion, speed, and direction.
- H. Anti-Two Block Device
- I. Hydraulic System: Hydraulic pilot operated control valves at the control station
- J. Control Station(s): Behind-the-cab and rear-mount models have curbside and street side walk-through control stations with grab handles for bed access. Riding seat models have dual control pods
- K. Operator Controls: Emergency stop, engine start/stop, and crane/outrigger mode switches
- L. Outrigger Boom Interlock System: Helps prevent operator from using unit until all outriggers are deployed
- M. Outrigger Motion Alarm: Provides audible alarm when any of the outriggers are in motion

- N. Outriggers: Primary outriggers and auxiliary outriggers out-and-down. Full-span spread is 18.5 feet (5.6 m), mid-span is 14 feet (4.3 m), and short-span is 9 feet (2.7 m)
- O. Outrigger Controls: Electric over hydraulic controls located at each rear corner of tail shelf providing a line-of-sight from the controls to the outrigger contact zone

We Wish To Thank You For Giving Us The Pleasure
And Opportunity of Serving You

UTILITY EQUIPMENT AND BODIES SINCE 1929

<u>Item</u>	<u>Description</u>	<u>Qty</u>	<u>Price</u>
	P. Paint: Altec 2-Stage Powder Coat Paint Process (Altec white is standard unless otherwise stated in options)		
	Q. Complies with ASME B30.5 Mobile Crane Standard		
	R. Manuals: Two (2) Operator's and two (2) Maintenance/Parts manuals		
	S. Basic Operation Videos: DVDs for Crane and LMAP		
2.	Behind Cab Mount	1	
3.	Non-continuous 370 degrees, front outrigger required	1	
4.	12,000 LB Two Speed Main Winch With Line Tensioner, Grooved Drum, And 3rd Wrap	1	
	Indicator		
5.	Starlift Xtra (Former Flex-X 35) Wire Rope - 350' Of 9/16" Diameter	1	
6.	Additional Sheave At Boom Tip, Jib Side	1	
7.	ATB Switch Cover	1	
8.	LMI Reel Tree Guard	1	
9.	Jib Not Required	1	
10.	Platform, Two-Man, 36 x 72 x 44.5 inch, Front Entry Gate, 800 lb Capacity	1	
11.	Platform Test Lift Package, 800 lb Capacity Platform. Supplied With One 800lbs Weight	1	
	And One 200lbs Weight.		
12.	AC23 Subbase For Out and Down Outriggers	1	
13.	Primary Out And Down Outriggers	1	
14.	Auxiliary Out And Down Outriggers	1	
15.	Front Bumper Outrigger, with electrical switch control on outrigger, required for 360	1	
	degree working capacity		
16.	Dual Walk Through Control Stations Mounted Each Side of Unit Pedestal	1	
17.	Left Hand Joystick Control/Right Hand Lever Controls (Standard for all Models)	1	
18.	Foot Throttles At Stand Up Control Stations	1	
19.	Drum Rotation Indicator, installed	1	
20.	Winch Disable Switch	1	

<u>Item</u>	<u>Description</u>	<u>Qty</u>	<u>Price</u>
21.	Telescope Disable Switch	1	
22.	Radio Remote Control for Crane Functions	1	
23.	Hirschmann LMAP System with Swing Arm Mount - Behind Cab or Rear Mount	1	
24.	Vinyl LMAP Display Cover With Altec Logo	1	
25.	Imperial/US Units of Measure for Capacity Charts and LMAP System	1	
26.	English Language for Capacity Charts, LMAP System, and Placards	1	
27.	AC23-95B-OD-ENG	1	
28.	Spanner Wrench - Crane Swing Drive Adjustment	1	
29.	Manual, Extra	1	
30.	Electric Over Hydraulic Outrigger Controls - Rocker Switches Installed On Tailshelf, Each	1	
31.	Side (Behind Cab/Rear Mount) Outrigger Down Jack Controls on Swing Arm for Stand Up Control Stations	1	
32.	Independent Beam and Down Jack Outrigger Operation	1	
33.	Altec Powder Coat Paint Process	1	
34.	Base Boom and Turntable Painted Altec White (Standard)	1	
35.	Extended Portions of Outriggers Painted Black (Standard)	1	
36.	Front Bumper Outrigger Painted Black (Standard)	1	
37.	Subbase Painted Black (Standard)	1	
38.	Upper Booms Powder Painted Black (Standard)	1	

Item	Description	Qty	Price
39.	Additional Unit Option - Additional radio remote control with charging station Unit & Hydraulic Acc.	1	
40.	Load Ball For 9/16" IWRC or 9/16" Flex-X Winch Rope	1	
41.	Load Ball Strap For Behind Cab Mounted Unit	1	
42.	Boom Winch Stow at Tail shelf	1	
43.	Front Bumper Outrigger Installation Components	1	
44.	Frame Stiffeners for Crane Subbase Installation	1	
45.	Subbase Installation Components	1	
46.	Load block, single sheave 2/3 part	1	
47.	Upright Load Block/Ball Stowage	1	
48.	HVI-22 Hydraulic Oil (Standard).	120	
49.	Single 90,000 BTU Cooler	1	
50.	Standard Pump For PTO	1	
51.	Hot shift PTO for automatic transmission	1	
52.	Standard Altec PTO/Machine Functionality: PTO won't engage until parking brake is set.	1	
	-Once parking (holding) brake is set, PTO and machine functions are enabled. -If parking (holding) brake is disengaged, both PTO and machine functions are disabled.		
53.	Altec recommends any connection made to the tool circuit be done with Non-Conductive hose. If ordering a Hose reel, Altec recommends ordering a hose reel with Non-Conductive hose. The lower tool circuit hoses may be, or become, conductive. Death or serious injury could occur if the unit becomes energized while lower tool circuit is in use.	1	
54.	Hydraulic Tools at Tail shelf	1	
55.	90 Gallon Reservoir On Bed - Behind Cab/Rear Mount	1	

Body

Item	Description	Qty	Price
56.	Altec Body	1	
57.	Aluminum Body	1	
58.	Body Is To Be Built In Accordance With The Following Altec Standard Specifications:	1	
	<ul style="list-style-type: none"> A. Basic Body Fabricated From 3003 Grade Mill finish Aluminum. B. All Doors Are Full, Double Paneled, Self-Sealed With Built-In Drainage For Maximum Weather-Tightness. Aluminum Hinge Rods Extend Full Length Of Door. C. Welded Aluminum Frame Construction With Structural Channel Crossmembers. D. Integrated Door Header Drip Rail At Top For Maximum Weather Protection. E. Fender Panels Are Either Roll Formed Or Have Neoprene Fenderettes Mechanically Fastened. F. Aluminum Treated For Improved Primer Bond And Corrosion Resistance. G. Automotive Type Non-Porous Door Seals Fastened To The Door Facing. 		
59.	Platform/Flatbed	1	
60.	Finish Paint Body Flatbed White (Applies To Steel And Aluminum)	1	
61.	Undercoat Body	1	
62.	264" Estimated Aluminum Flatbed Length (Engineering To Determine Final Length)	1	
63.	1/4" Aluminum Tread plate Floor	1	
64.	96" Body Width	1	
65.	4 High Flatbed (No Cross Storage Available)	1	
66.	Stake Pockets on Sides and Rear of Flatbed, Installed on 24" Centers Outside of Frame	1	
67.	6 Inch High Removable Aluminum Stake Sides	1	
68.	Outrigger Cutout Required	1	
69.	Unit Cutout Required	1	
70.	Light Channels Installed At Rear Of Flatbed	1	
71.	Rub rails on Sides of Flatbed	1	

Body and Chassis Accessories

We Wish To Thank You For Giving Us The Pleasure
And Opportunity of Serving You

UTILITY EQUIPMENT AND BODIES SINCE 1929

Item	Description	Qty	Price
72.	ICC (Underride Protection) Bumper Installed At Rear	1	
73.	Buyers PH20 Style Pintle hitch (40,000 lb.)	1	
74.	Eyebolt For Breakaway Cable, 1/4 Inch	1	
75.	Set Of D-Rings for Trailer Safety Chain, installed one each side of towing device mount.	1	
76.	Standard Boom Rest, removable, installed behind cab	1	
77.	- Removable boom rest Mounting Brackets for Lights, Located on Lower Boom Rest	1	
78.	Plastic Outrigger Pad, 30" x 30" x 2", Black With Rope Handle	4	
79.	Outrigger Pad Holder, 31" x 31" x 4", Steel, For Multiple 30" x 30" x 2" Outrigger Pad And Smaller, Chain and Hasp Retainer, Underbody Box Mounted Only	4	
80.	Mud Flaps With Altec Logo (Pair)	1	
81.	Wheel Chocks, Rubber, 9.75" L x 7.75" W x 5.00" H, with 4" L Metal Hairpin Style Handle	2	
82.	(Pair) Wheel Chock Holders (Pair), For Installation Under Flatbed Or Dump Body	2	
83.	- Aluminum Underbody Storage Box, Aluminum Tread plate, 36" L x 18" W x 18" H, One (1) Drop-Down Door, One (1) T-Handle Latch, Cable Stops (Buyers Products) - Two (2) located on the curb side - Two (2) located on the street side	4	
84.	Safety Harness & 4.5 FT Lanyard (Medium To X-large)	2	
85.	Triangular Reflector Kit, Installed	1	
86.	5 LB Fire Extinguisher With Light Duty Bracket, Shipped Loose	1	
87.	Vinyl manual pouch for storage of all operator and parts manuals	1	
88.	Soft Vinyl Lanyard Pouch	1	
Electrical Accessories			
89.	Lights and reflectors in accordance with FMVSS #108 lighting package. (Complete LED, including LED reverse lights)	1	

Item	Description	Qty	Price
90.	Custom Strobe Light	1	
	<ul style="list-style-type: none"> - Six (6) oval LED strobe lights - Two (2) at the front, two (2) on the sides, and two (2) at the rear - 1-5/8" high x 5" wide Whelen 500 series 		
91.	Strobe Lights Wired Ignition Hot	1	
92.	Flood Light, LED, With Aluminum Housing, 4.25" W x 4.25" H, No Switch on the Light	4	
	<ul style="list-style-type: none"> - One on each control station - One on each side of the boom rest 		
93.	Auxiliary Lighting Wired Ignition Hot	1	
94.	Dual Tone Back-Up With Outrigger Motion Alarm	1	
95.	PTO Hour Meter, Analog, with 10,000 Hour Display	1	
96.	7-Way Trailer Receptacle (Pin Type) Installed At Rear	1	
97.	Electric Trailer Brake Controller (Tekonsha Voyager #9030)	1	
98.	Inverter, 2400 Watt, Pure Sine Wave, 120 VAC (Sensata #12/2400N)	1	
	- Will be used to charge wireless headset and radio equipment		
99.	Inverter Wired Ignition Hot with Dash Mounted Switch	1	
100.	Pdm Module, Installed On Back Wall Of Cab/Chassis	1	
101.	Additional Electrical Accessory	1	
	<ul style="list-style-type: none"> - Team wireless system - Three (3) Apex 3-series wireless headsets with com-hub - 2-Way Radio Sonetics Model #SONPWS-DECT7 - Cab mounted battery charger 		
Installation			
102.	Manual Kit (Includes (2) Operators Manuals, (2) Parts and Maintenance Manuals, (1) Operational and Safety DVD	1	
Finishing Details			
103.	Altec Standard; Components mounted below frame rail shall be coated black by Altec. i.e.	1	
	<p>step bumpers, steps, frame extension, pintle hook mount, dock bumper mounts, D-rings, receiver tubes, accessory mounts, light brackets, under-ride protection, etc. Components mounted to under side of body shall be coated black by Altec. i.e. Wheel chock holders, mud flap brackets, pad carriers, boxes, lighting brackets, steps, and ladders.</p>		

Item	Description	Qty	Price
104.	Apply Non-Skid Coating to all walking surfaces	1	
105.	Custom Cargo Coating - Black Gator Hyde - Entire ICC bumper	1	
106.	English Safety And Instructional Decals	1	
107.	Vehicle Height Placard - Installed In Cab	1	
108.	Placard, HVI-22 Hydraulic Oil	1	
109.	Stability test unit according to ANSI requirements.	1	
110.	Delivery Of Completed Unit	1	
111.	Focus Factory Build	1	
112.	Final Assembly	1	
Miscellaneous			
113.	Standard Altec Crane/HiLine Warranty: One (1) year parts warranty, one (1) year labor warranty, ninety (90) days warranty for travel charges, five (5) year structural warranty	1	
114.	Ext Warranty Labor, Mat., Expense (NO Travel) (Day 366-1095) Cranes AC26/28	1	

Notes:

We Wish To Thank You For Giving Us The Pleasure
And Opportunity of Serving You
UTILITY EQUIPMENT AND BODIES SINCE 1929