



Purchasing Division
 2019 Washington Street East
 Post Office Box 50130
 Charleston, WV 25305-0130

State of West Virginia
 Request for Quotation
 36 - Vehicles

Proc Folder: 363203

Doc Description: 19,000 GVWR 4X4 CREW CAB W/ ALUM CLOSED-TOP SERVICE BODY

Proc Type: Central Master Agreement

Date Issued	Solicitation Closes	Solicitation No	Version
2017-08-15	2017-09-26 13:30:00	CRFQ 0803 DOT1800000013	1

BID RECEIVING LOCATION

BID CLERK
 DEPARTMENT OF ADMINISTRATION
 PURCHASING DIVISION
 2019 WASHINGTON ST E
 CHARLESTON WV 25305
 US

VENDOR

Vendor Name, Address and Telephone Number:

Thornhill Ford
 500 Ford Fairlane
 Chapmanville, WV 25508
 304-855-8300

09/26/17 13:11:05
 WV Purchasing Division

FOR INFORMATION CONTACT THE BUYER

Mark A Atkins
 (304) 558-2307
 mark.a.atkins@wv.gov

Signature X

Charles Ellis

FEIN # 20-3146880

DATE 9/26/17

All offers subject to all terms and conditions contained in this solicitation

ADDITIONAL INFORMATION:

The West Virginia Purchasing Division is soliciting bids on behalf of the West Virginia Division of Highways (WVDOH), West Virginia Department of Transportation (WVDOT), to establish an open-end contract for a 19,000 GVWR 4-Wheel Drive Crew Cab Truck with Aluminum Closed Top Service Body per attached documents.

INVOICE TO	SHIP TO
DIVISION OF HIGHWAYS EQUIPMENT DIVISION RT 33 83 BRUSHY ROAD CROSSING, PO BOX 610 BUCKHANNON WV26201 US	DIVISION OF HIGHWAYS EQUIPMENT DIVISION 83 BRUSHY FORK RD CROSSING BUCKHANNON WV 26201 US

Line	Comm Ln Desc	Qty	Unit Issue	Unit Price	Total Price
1	COMPLETE UNIT -19,000 GVWR 4X4 CREW CAB W/ALUMINUM	80.00000	EA		

Comm Code	Manufacturer	Specification	Model #
25101601			

Extended Description :

19,000 GVWR 4X4 CREW CAB 4-DOOR TRUCK WITH ALUMINUM CLOSED-TOP SERVICE BODY:

Make:

Model:

Year:

SCHEDULE OF EVENTS

Line	Event	Event Date
1	Mandatory Pre-Bid Meeting 11:00am:	2017-09-07
2	Technical Questions due by:	2017-09-13

DOT1800000013	Document Phase Final	Document Description 19,000 GVWR 4X4 CREW CAB W/ ALUM CLOSED-TOP SERVICE BODY	Page 3 of 3
----------------------	--------------------------------	--	------------------------------

ADDITIONAL TERMS AND CONDITIONS

See attached document(s) for additional Terms and Conditions

INSTRUCTIONS TO VENDORS SUBMITTING BIDS

1. REVIEW DOCUMENTS THOROUGHLY: The attached documents contain a solicitation for bids. Please read these instructions and all documents attached in their entirety. These instructions provide critical information about requirements that if overlooked could lead to disqualification of a Vendor's bid. All bids must be submitted in accordance with the provisions contained in these instructions and the Solicitation. Failure to do so may result in disqualification of Vendor's bid.

2. MANDATORY TERMS: The Solicitation may contain mandatory provisions identified by the use of the words "must," "will," and "shall." Failure to comply with a mandatory term in the Solicitation will result in bid disqualification.

3. PREBID MEETING: The item identified below shall apply to this Solicitation.

A pre-bid meeting will not be held prior to bid opening

A **NON-MANDATORY PRE-BID** meeting will be held at the following place and time:

A **MANDATORY PRE-BID** meeting will be held at the following place and time:

Date: 09/07/2017

Time: 11:00 AM

WV Division of Highways
Equipment Division
83 Brushy Fork RD Crossing
Buckhannon, WV 26201

All Vendors submitting a bid must attend the mandatory pre-bid meeting. Failure to attend the mandatory pre-bid meeting shall result in disqualification of the Vendor's bid. No one person attending the pre-bid meeting may represent more than one Vendor.

An attendance sheet provided at the pre-bid meeting shall serve as the official document verifying attendance. The State will not accept any other form of proof or documentation to verify attendance. Any person attending the pre-bid meeting on behalf of a Vendor must list on the attendance sheet his or her name and the name of the Vendor he or she is representing.

Additionally, the person attending the pre-bid meeting should include the Vendor's E-Mail address, phone number, and Fax number on the attendance sheet. It is the Vendor's responsibility to locate the attendance sheet and provide the required information. Failure to complete the attendance sheet as required may result in disqualification of Vendor's bid.

All Vendors should arrive prior to the starting time for the pre-bid. Vendors who arrive after the starting time but prior to the end of the pre-bid will be permitted to sign in, but are charged with knowing all matters discussed at the pre-bid.

Questions submitted at least five business days prior to a scheduled pre-bid will be discussed at the pre-bid meeting if possible. Any discussions or answers to questions at the pre-bid meeting are preliminary in nature and are non-binding. Official and binding answers to questions will be published in a written addendum to the Solicitation prior to bid opening.

4. VENDOR QUESTION DEADLINE: Vendors may submit questions relating to this Solicitation to the Purchasing Division. Questions must be submitted in writing. All questions must be submitted on or before the date listed below and to the address listed below in order to be considered. A written response will be published in a Solicitation addendum if a response is possible and appropriate. Non-written discussions, conversations, or questions and answers regarding this Solicitation are preliminary in nature and are nonbinding.

Submitted e-mails should have solicitation number in the subject line.

Question Submission Deadline: **September 13, 2017**

Submit Questions to: Mark Atkins, Senior Buyer
2019 Washington Street, East
Charleston, WV 25305
Fax: (304) 558-4115 (Vendors should not use this fax number for bid submission)
Email: Mark.A.Atkins@wv.gov

5. VERBAL COMMUNICATION: Any verbal communication between the Vendor and any State personnel is not binding, including verbal communication at the mandatory pre-bid conference. Only information issued in writing and added to the Solicitation by an official written addendum by the Purchasing Division is binding.

6. BID SUBMISSION: All bids must be submitted electronically through wvOASIS or signed and delivered by the Vendor to the Purchasing Division at the address listed below on or before the date and time of the bid opening. Any bid received by the Purchasing Division staff is considered to be in the possession of the Purchasing Division and will not be returned for any reason. The Purchasing Division will not accept bids, modification of bids, or addendum acknowledgment forms via e-mail. Acceptable delivery methods include electronic submission via wvOASIS, hand delivery, delivery by courier, or facsimile.

The bid delivery address is:
Department of Administration, Purchasing Division
2019 Washington Street East
Charleston, WV 25305-0130

A bid that is not submitted electronically through wvOASIS should contain the information listed below on the face of the envelope or the bid may be rejected by the Purchasing Division.:

SEALED BID: 4x4 Truck with Closed Top Service Body
BUYER: Mark Atkins, File#33
SOLICITATION NO.: CRFQ 0803 DOT1800000013
BID OPENING DATE: 09/26/2017
BID OPENING TIME: 1:30pm EST
FAX NUMBER: 304-558-3970

The Purchasing Division may prohibit the submission of bids electronically through wvOASIS at its sole discretion. Such a prohibition will be contained and communicated in the wvOASIS system resulting in the Vendor's inability to submit bids through wvOASIS. Submission of a response to an Expression or Interest or Request for Proposal is not permitted in wvOASIS.

For Request For Proposal ("RFP") Responses Only: In the event that Vendor is responding to a request for proposal, the Vendor shall submit one original technical and one original cost proposal plus N/A convenience copies of each to the Purchasing Division at the address shown above. Additionally, the Vendor should identify the bid type as either a technical or cost proposal on the face of each bid envelope submitted in response to a request for proposal as follows:

BID TYPE: (This only applies to CRFP)

- Technical
 Cost

7. BID OPENING: Bids submitted in response to this Solicitation will be opened at the location identified below on the date and time listed below. Delivery of a bid after the bid opening date and time will result in bid disqualification. For purposes of this Solicitation, a bid is considered delivered when confirmation of delivery is provided by wvOASIS (in the case of electronic submission) or when the bid is time stamped by the official Purchasing Division time clock (in the case of hand delivery).

Bid Opening Date and Time: September 26, 2017 @ 1:30pm EST

Bid Opening Location: Department of Administration, Purchasing Division
2019 Washington Street East
Charleston, WV 25305-0130

- 8. ADDENDUM ACKNOWLEDGEMENT:** Changes or revisions to this Solicitation will be made by an official written addendum issued by the Purchasing Division. Vendor should acknowledge receipt of all addenda issued with this Solicitation by completing an Addendum Acknowledgment Form, a copy of which is included herewith. Failure to acknowledge addenda may result in bid disqualification. The addendum acknowledgement should be submitted with the bid to expedite document processing.
- 9. BID FORMATTING:** Vendor should type or electronically enter the information onto its bid to prevent errors in the evaluation. Failure to type or electronically enter the information may result in bid disqualification.
- 10. ALTERNATES:** Any model, brand, or specification listed in this Solicitation establishes the acceptable level of quality only and is not intended to reflect a preference for, or in any way favor, a particular brand or vendor. Vendors may bid alternates to a listed model or brand provided that the alternate is at least equal to the model or brand and complies with the required specifications. The equality of any alternate being bid shall be determined by the State at its sole discretion. Any Vendor bidding an alternate model or brand should clearly identify the alternate items in its bid and should include manufacturer's specifications, industry literature, and/or any other relevant documentation demonstrating the equality of the alternate items. Failure to provide information for alternate items may be grounds for rejection of a Vendor's bid.
- 11. EXCEPTIONS AND CLARIFICATIONS:** The Solicitation contains the specifications that shall form the basis of a contractual agreement. Vendor shall clearly mark any exceptions, clarifications, or other proposed modifications in its bid. Exceptions to, clarifications of, or modifications of a requirement or term and condition of the Solicitation may result in bid disqualification.
- 12. COMMUNICATION LIMITATIONS:** In accordance with West Virginia Code of State Rules §148-1-6.6, communication with the State of West Virginia or any of its employees regarding this Solicitation during the solicitation, bid, evaluation or award periods, except through the Purchasing Division, is strictly prohibited without prior Purchasing Division approval. Purchasing Division approval for such communication is implied for all agency delegated and exempt purchases.
- 13. REGISTRATION:** Prior to Contract award, the apparent successful Vendor must be properly registered with the West Virginia Purchasing Division and must have paid the \$125 fee, if applicable.
- 14. UNIT PRICE:** Unit prices shall prevail in cases of a discrepancy in the Vendor's bid.
- 15. PREFERENCE:** Vendor Preference may only be granted upon written request and only in accordance with the West Virginia Code § 5A-3-37 and the West Virginia Code of State Rules. A Vendor Preference Certificate form has been attached hereto to allow Vendor to apply for the preference. Vendor's failure to submit the Vendor Preference Certificate form with its bid will result in denial of Vendor Preference. Vendor Preference does not apply to construction projects.

16. SMALL, WOMEN-OWNED, OR MINORITY-OWNED BUSINESSES: For any solicitations publicly advertised for bid, in accordance with West Virginia Code §5A-3-37(a)(7) and W. Va. CSR § 148-22-9, any non-resident vendor certified as a small, women-owned, or minority-owned business under W. Va. CSR § 148-22-9 shall be provided the same preference made available to any resident vendor. Any non-resident small, women-owned, or minority-owned business must identify itself as such in writing, must submit that writing to the Purchasing Division with its bid, and must be properly certified under W. Va. CSR § 148-22-9 prior to contract award to receive the preferences made available to resident vendors. Preference for a non-resident small, women-owned, or minority owned business shall be applied in accordance with W. Va. CSR § 148-22-9.

17. WAIVER OF MINOR IRREGULARITIES: The Director reserves the right to waive minor irregularities in bids or specifications in accordance with West Virginia Code of State Rules § 148-1-4.6.

18. ELECTRONIC FILE ACCESS RESTRICTIONS: Vendor must ensure that its submission in wvOASIS can be accessed and viewed by the Purchasing Division staff immediately upon bid opening. The Purchasing Division will consider any file that cannot be immediately accessed and viewed at the time of the bid opening (such as, encrypted files, password protected files, or incompatible files) to be blank or incomplete as context requires, and are therefore unacceptable. A vendor will not be permitted to unencrypt files, remove password protections, or resubmit documents after bid opening to make a file viewable if those documents are required with the bid. A Vendor may be required to provide document passwords or remove access restrictions to allow the Purchasing Division to print or electronically save documents provided that those documents are viewable by the Purchasing Division prior to obtaining the password or removing the access restriction.

19. NON-RESPONSIBLE: The Purchasing Division Director reserves the right to reject the bid of any vendor as Non-Responsible in accordance with W. Va. Code of State Rules § 148-1-5.3, when the Director determines that the vendor submitting the bid does not have the capability to fully perform, or lacks the integrity and reliability to assure good-faith performance.”

20. ACCEPTANCE/REJECTION: The State may accept or reject any bid in whole, or in part in accordance with W. Va. Code of State Rules § 148-1-4.5. and § 148-1-6.4.b.”

21. YOUR SUBMISSION IS A PUBLIC DOCUMENT: Vendor's entire response to the Solicitation and the resulting Contract are public documents. As public documents, they will be disclosed to the public following the bid/proposal opening or award of the contract, as required by the competitive bidding laws of West Virginia Code §§ 5A-3-1 et seq., 5-22-1 et seq., and 5G-1-1 et seq. and the Freedom of Information Act West Virginia Code §§ 29B-1-1 et seq.

DO NOT SUBMIT MATERIAL YOU CONSIDER TO BE CONFIDENTIAL, A TRADE SECRET, OR OTHERWISE NOT SUBJECT TO PUBLIC DISCLOSURE.

Submission of any bid, proposal, or other document to the Purchasing Division constitutes your explicit consent to the subsequent public disclosure of the bid, proposal, or document. The Purchasing Division will disclose any document labeled "confidential," "proprietary," "trade secret," "private," or labeled with any other claim against public disclosure of the documents, to include any "trade secrets" as defined by West Virginia Code § 47-22-1 et seq. All submissions are subject to public disclosure without notice.

22. INTERESTED PARTY DISCLOSURE: W. Va. Code § 6D-1-2 requires that for contracts with an actual or estimated value of at least \$100,000, the vendor must submit to the Purchasing Division a disclosure of interested parties to the contract, prior to contract award. That disclosure must occur on the form prescribed and approved by the WV Ethics Commission. A copy of that form is included with this solicitation or can be obtained from the WV Ethics Commission. "Interested parties" means: (1) A business entity performing work or service pursuant to, or in furtherance of, the applicable contract, including specifically sub-contractors; (2) the person(s) who have an ownership interest equal to or greater than 25% in the business entity performing work or service pursuant to, or in furtherance of, the applicable contract; and (3) the person or business entity, if any, that served as a compensated broker or intermediary to actively facilitate the applicable contract or negotiated the terms of the applicable contract with the state agency: Provided, That subdivision (2) shall be inapplicable if a business entity is a publicly traded company: Provided, however, That subdivision (3) shall not include persons or business entities performing legal services related to the negotiation or drafting of the applicable contract.

GENERAL TERMS AND CONDITIONS:

1. **CONTRACTUAL AGREEMENT:** Issuance of a Award Document signed by the Purchasing Division Director, or his designee, and approved as to form by the Attorney General's office constitutes acceptance of this Contract made by and between the State of West Virginia and the Vendor. Vendor's signature on its bid signifies Vendor's agreement to be bound by and accept the terms and conditions contained in this Contract.
2. **DEFINITIONS:** As used in this Solicitation/Contract, the following terms shall have the meanings attributed to them below. Additional definitions may be found in the specifications included with this Solicitation/Contract.
 - 2.1. **"Agency" or "Agencies"** means the agency, board, commission, or other entity of the State of West Virginia that is identified on the first page of the Solicitation or any other public entity seeking to procure goods or services under this Contract.
 - 2.2. **"Bid" or "Proposal"** means the vendors submitted response to this solicitation.
 - 2.3. **"Contract"** means the binding agreement that is entered into between the State and the Vendor to provide the goods or services requested in the Solicitation.
 - 2.4. **"Director"** means the Director of the West Virginia Department of Administration, Purchasing Division.
 - 2.5. **"Purchasing Division"** means the West Virginia Department of Administration, Purchasing Division.
 - 2.6. **"Award Document"** means the document signed by the Agency and the Purchasing Division, and approved as to form by the Attorney General, that identifies the Vendor as the contract holder.
 - 2.7. **"Solicitation"** means the official notice of an opportunity to supply the State with goods or services that is published by the Purchasing Division.
 - 2.8. **"State"** means the State of West Virginia and/or any of its agencies, commissions, boards, etc. as context requires.
 - 2.9. **"Vendor" or "Vendors"** means any entity submitting a bid in response to the Solicitation, the entity that has been selected as the lowest responsible bidder, or the entity that has been awarded the Contract as context requires.

3. CONTRACT TERM; RENEWAL; EXTENSION: The term of this Contract shall be determined in accordance with the category that has been identified as applicable to this Contract below:

Term Contract

Initial Contract Term: This Contract becomes effective on upon award and extends for a period of one (1) year(s).

Renewal Term: This Contract may be renewed upon the mutual written consent of the Agency, and the Vendor, with approval of the Purchasing Division and the Attorney General's office (Attorney General approval is as to form only). Any request for renewal should be submitted to the Purchasing Division thirty (30) days prior to the expiration date of the initial contract term or appropriate renewal term. A Contract renewal shall be in accordance with the terms and conditions of the original contract. Renewal of this Contract is limited to three (3) successive one (1) year periods or multiple renewal periods of less than one year, provided that the multiple renewal periods do not exceed thirty-six (36) months in total. Automatic renewal of this Contract is prohibited. Notwithstanding the foregoing, Purchasing Division approval is not required on agency delegated or exempt purchases. Attorney General approval may be required for vendor terms and conditions.

Delivery Order Limitations: In the event that this contract permits delivery orders, a delivery order may only be issued during the time this Contract is in effect. Any delivery order issued within one year of the expiration of this Contract shall be effective for one year from the date the delivery order is issued. No delivery order may be extended beyond one year after this Contract has expired.

Fixed Period Contract: This Contract becomes effective upon Vendor's receipt of the notice to proceed and must be completed within _____ days.

Fixed Period Contract with Renewals: This Contract becomes effective upon Vendor's receipt of the notice to proceed and part of the Contract more fully described in the attached specifications must be completed within _____ days.

Upon completion, the vendor agrees that maintenance, monitoring, or warranty services will be provided for one year thereafter with an additional _____ successive one year renewal periods or multiple renewal periods of less than one year provided that the multiple renewal periods do not exceed _____ months in total. Automatic renewal of this Contract is prohibited.

One Time Purchase: The term of this Contract shall run from the issuance of the Award Document until all of the goods contracted for have been delivered, but in no event will this Contract extend for more than one fiscal year.

Other: See attached.

4. NOTICE TO PROCEED: Vendor shall begin performance of this Contract immediately upon receiving notice to proceed unless otherwise instructed by the Agency. Unless otherwise specified, the fully executed Award Document will be considered notice to proceed.

5. QUANTITIES: The quantities required under this Contract shall be determined in accordance with the category that has been identified as applicable to this Contract below.

Open End Contract: Quantities listed in this Solicitation are approximations only, based on estimates supplied by the Agency. It is understood and agreed that the Contract shall cover the quantities actually ordered for delivery during the term of the Contract, whether more or less than the quantities shown.

Service: The scope of the service to be provided will be more clearly defined in the specifications included herewith.

Combined Service and Goods: The scope of the service and deliverable goods to be provided will be more clearly defined in the specifications included herewith.

One Time Purchase: This Contract is for the purchase of a set quantity of goods that are identified in the specifications included herewith. Once those items have been delivered, no additional goods may be procured under this Contract without an appropriate change order approved by the Vendor, Agency, Purchasing Division, and Attorney General's office.

6. EMERGENCY PURCHASES: The Purchasing Division Director may authorize the Agency to purchase goods or services in the open market that Vendor would otherwise provide under this Contract if those goods or services are for immediate or expedited delivery in an emergency. Emergencies shall include, but are not limited to, delays in transportation or an unanticipated increase in the volume of work. An emergency purchase in the open market, approved by the Purchasing Division Director, shall not constitute a breach of this Contract and shall not entitle the Vendor to any form of compensation or damages. This provision does not excuse the State from fulfilling its obligations under a One Time Purchase contract.

7. REQUIRED DOCUMENTS: All of the items checked below must be provided to the Purchasing Division by the Vendor as specified below.

BID BOND (Construction Only): Pursuant to the requirements contained in W. Va. Code § 5-22-1(c), All Vendors submitting a bid on a construction project shall furnish a valid bid bond in the amount of five percent (5%) of the total amount of the bid protecting the State of West Virginia. The bid bond must be submitted with the bid.

PERFORMANCE BOND: The apparent successful Vendor shall provide a performance bond in the amount of _____. The performance bond must be received by the Purchasing Division prior to Contract award. On construction contracts, the performance bond must be 100% of the Contract value.

LABOR/MATERIAL PAYMENT BOND: The apparent successful Vendor shall provide a labor/material payment bond in the amount of 100% of the Contract value. The labor/material payment bond must be delivered to the Purchasing Division prior to Contract award.

In lieu of the Bid Bond, Performance Bond, and Labor/Material Payment Bond, the Vendor may provide certified checks, cashier's checks, or irrevocable letters of credit. Any certified check, cashier's check, or irrevocable letter of credit provided in lieu of a bond must be of the same amount and delivered on the same schedule as the bond it replaces. A letter of credit submitted in lieu of a performance and labor/material payment bond will only be allowed for projects under \$100,000. Personal or business checks are not acceptable. Notwithstanding the foregoing, West Virginia Code § 5-22-1 (d) mandates that a vendor provide a performance and labor/material payment bond for construction projects. Accordingly, substitutions for the performance and labor/material payment bonds for construction projects is not permitted.

MAINTENANCE BOND: The apparent successful Vendor shall provide a two (2) year maintenance bond covering the roofing system. The maintenance bond must be issued and delivered to the Purchasing Division prior to Contract award.

LICENSE(S) / CERTIFICATIONS / PERMITS: In addition to anything required under the Section entitled Licensing, of the General Terms and Conditions, the apparent successful Vendor shall furnish proof of the following licenses, certifications, and/or permits prior to Contract award, in a form acceptable to the Purchasing Division.

The apparent successful Vendor shall also furnish proof of any additional licenses or certifications contained in the specifications prior to Contract award regardless of whether or not that requirement is listed above.

8. INSURANCE: The apparent successful Vendor shall furnish proof of the insurance identified by a checkmark below prior to Contract award. Subsequent to contract award, and prior to the insurance expiration date, Vendor shall provide the Agency with proof that the insurance mandated herein has been continued. Vendor must also provide Agency with immediate notice of any changes in its insurance policies mandated herein, including but not limited to, policy cancelation, policy reduction, or change in insurers. The insurance coverages identified below must be maintained throughout the life of this contract. The apparent successful Vendor shall also furnish proof of any additional insurance requirements contained in the specifications prior to Contract award regardless of whether or not that insurance requirement is listed in this section.

Vendor must maintain:

Commercial General Liability Insurance in at least an amount of:

Automobile Liability Insurance in at least an amount of: _____

Professional/Malpractice/Errors and Omission Insurance in at least an amount of:

Commercial Crime and Third Party Fidelity Insurance in an amount of:

Cyber Liability Insurance in an amount of: _____

Builders Risk Insurance in an amount equal to 100% of the amount of the Contract.

9. WORKERS' COMPENSATION INSURANCE: The apparent successful Vendor shall comply with laws relating to workers compensation, shall maintain workers' compensation insurance when required, and shall furnish proof of workers' compensation insurance upon request.

10. LITIGATION BOND: The Director reserves the right to require any Vendor that files a protest of an award to submit a litigation bond in the amount equal to one percent of the lowest bid submitted or \$5,000, whichever is greater. The entire amount of the bond shall be forfeited if the hearing officer determines that the protest was filed for frivolous or improper purpose, including but not limited to, the purpose of harassing, causing unnecessary delay, or needless expense for the Agency. All litigation bonds shall be made payable to the Purchasing Division. In lieu of a bond, the protester may submit a cashier's check or certified check payable to the Purchasing Division. Cashier's or certified checks will be deposited with and held by the State Treasurer's office. If it is determined that the protest has not been filed for frivolous or improper purpose, the bond or deposit shall be returned in its entirety.

11. LIQUIDATED DAMAGES: Vendor shall pay liquidated damages in the amount of

n/a

for n/a

This clause shall in no way be considered exclusive and shall not limit the State or Agency's right to pursue any other available remedy.

12. ACCEPTANCE: Vendor's signature on its bid, or on the certification and signature page, constitutes an offer to the State that cannot be unilaterally withdrawn, signifies that the product or service proposed by vendor meets the mandatory requirements contained in the Solicitation for that product or service, unless otherwise indicated, and signifies acceptance of the terms and conditions contained in the Solicitation unless otherwise indicated.

13. PRICING: The pricing set forth herein is firm for the life of the Contract, unless specified elsewhere within this Solicitation/Contract by the State. A Vendor's inclusion of price adjustment provisions in its bid, without an express authorization from the State in the Solicitation to do so, may result in bid disqualification.

14. PAYMENT: Payment in advance is prohibited under this Contract. Payment may only be made after the delivery and acceptance of goods or services. The Vendor shall submit invoices, in arrears.

15. PURCHASING CARD ACCEPTANCE: The State of West Virginia currently utilizes a Purchasing Card program, administered under contract by a banking institution, to process payment for goods and services. The Vendor must accept the State of West Virginia's Purchasing Card for payment of all orders under this Contract unless the box below is checked.

Vendor is not required to accept the State of West Virginia's Purchasing Card as payment for all goods and services.

- 16. TAXES:** The Vendor shall pay any applicable sales, use, personal property or any other taxes arising out of this Contract and the transactions contemplated thereby. The State of West Virginia is exempt from federal and state taxes and will not pay or reimburse such taxes.
- 17. ADDITIONAL FEES:** Vendor is not permitted to charge additional fees or assess additional charges that were not either expressly provided for in the solicitation published by the State of West Virginia or included in the unit price or lump sum bid amount that Vendor is required by the solicitation to provide. Including such fees or charges as notes to the solicitation may result in rejection of vendor's bid. Requesting such fees or charges be paid after the contract has been awarded may result in cancellation of the contract.
- 18. FUNDING:** This Contract shall continue for the term stated herein, contingent upon funds being appropriated by the Legislature or otherwise being made available. In the event funds are not appropriated or otherwise made available, this Contract becomes void and of no effect beginning on July 1 of the fiscal year for which funding has not been appropriated or otherwise made available.
- 19. CANCELLATION:** The Purchasing Division Director reserves the right to cancel this Contract immediately upon written notice to the vendor if the materials or workmanship supplied do not conform to the specifications contained in the Contract. The Purchasing Division Director may also cancel any purchase or Contract upon 30 days written notice to the Vendor in accordance with West Virginia Code of State Rules § 148-1-6.1.e.
- 20. TIME:** Time is of the essence with regard to all matters of time and performance in this Contract.
- 21. APPLICABLE LAW:** This Contract is governed by and interpreted under West Virginia law without giving effect to its choice of law principles. Any information provided in specification manuals, or any other source, verbal or written, which contradicts or violates the West Virginia Constitution, West Virginia Code or West Virginia Code of State Rules is void and of no effect.
- 22. COMPLIANCE WITH LAWS:** Vendor shall comply with all applicable federal, state, and local laws, regulations and ordinances. By submitting a bid, Vendor acknowledges that it has reviewed, understands, and will comply with all applicable laws, regulations, and ordinances.
- 23. ARBITRATION:** Any references made to arbitration contained in this Contract, Vendor's bid, or in any American Institute of Architects documents pertaining to this Contract are hereby deleted, void, and of no effect.

- 24. MODIFICATIONS:** This writing is the parties' final expression of intent. Notwithstanding anything contained in this Contract to the contrary no modification of this Contract shall be binding without mutual written consent of the Agency, and the Vendor, with approval of the Purchasing Division and the Attorney General's office (Attorney General approval is as to form only). Any change to existing contracts that adds work or changes contract cost, and were not included in the original contract, must be approved by the Purchasing Division and the Attorney General's Office (as to form) prior to the implementation of the change or commencement of work affected by the change.
- 25. WAIVER:** The failure of either party to insist upon a strict performance of any of the terms or provision of this Contract, or to exercise any option, right, or remedy herein contained, shall not be construed as a waiver or a relinquishment for the future of such term, provision, option, right, or remedy, but the same shall continue in full force and effect. Any waiver must be expressly stated in writing and signed by the waiving party.
- 26. SUBSEQUENT FORMS:** The terms and conditions contained in this Contract shall supersede any and all subsequent terms and conditions which may appear on any form documents submitted by Vendor to the Agency or Purchasing Division such as price lists, order forms, invoices, sales agreements, or maintenance agreements, and includes internet websites or other electronic documents. Acceptance or use of Vendor's forms does not constitute acceptance of the terms and conditions contained thereon.
- 27. ASSIGNMENT:** Neither this Contract nor any monies due, or to become due hereunder, may be assigned by the Vendor without the express written consent of the Agency, the Purchasing Division, the Attorney General's office (as to form only), and any other government agency or office that may be required to approve such assignments. Notwithstanding the foregoing, Purchasing Division approval may or may not be required on certain agency delegated or exempt purchases.
- 28. WARRANTY:** The Vendor expressly warrants that the goods and/or services covered by this Contract will: (a) conform to the specifications, drawings, samples, or other description furnished or specified by the Agency; (b) be merchantable and fit for the purpose intended; and (c) be free from defect in material and workmanship.
- 29. STATE EMPLOYEES:** State employees are not permitted to utilize this Contract for personal use and the Vendor is prohibited from permitting or facilitating the same.
- 30. BANKRUPTCY:** In the event the Vendor files for bankruptcy protection, the State of West Virginia may deem this Contract null and void, and terminate this Contract without notice.
- 31. PRIVACY, SECURITY, AND CONFIDENTIALITY:** The Vendor agrees that it will not disclose to anyone, directly or indirectly, any such personally identifiable information or other confidential information gained from the Agency, unless the individual who is the subject of the information consents to the disclosure in writing or the disclosure is made pursuant to the Agency's policies, procedures, and rules. Vendor further agrees to comply with the Confidentiality Policies and Information Security Accountability Requirements, set forth in <http://www.state.wv.us/admin/purchase/privacy/default.html>.

32. YOUR SUBMISSION IS A PUBLIC DOCUMENT: Vendor's entire response to the Solicitation and the resulting Contract are public documents. As public documents, they will be disclosed to the public following the bid/proposal opening or award of the contract, as required by the competitive bidding laws of West Virginia Code §§ 5A-3-1 et seq., 5-22-1 et seq., and 5G-1-1 et seq. and the Freedom of Information Act West Virginia Code §§ 29B-1-1 et seq.

DO NOT SUBMIT MATERIAL YOU CONSIDER TO BE CONFIDENTIAL, A TRADE SECRET, OR OTHERWISE NOT SUBJECT TO PUBLIC DISCLOSURE.

Submission of any bid, proposal, or other document to the Purchasing Division constitutes your explicit consent to the subsequent public disclosure of the bid, proposal, or document. The Purchasing Division will disclose any document labeled "confidential," "proprietary," "trade secret," "private," or labeled with any other claim against public disclosure of the documents, to include any "trade secrets" as defined by West Virginia Code § 47-22-1 et seq. All submissions are subject to public disclosure without notice.

33. LICENSING: In accordance with West Virginia Code of State Rules § 148-1-6.1.e, Vendor must be licensed and in good standing in accordance with any and all state and local laws and requirements by any state or local agency of West Virginia, including, but not limited to, the West Virginia Secretary of State's Office, the West Virginia Tax Department, West Virginia Insurance Commission, or any other state agency or political subdivision. Upon request, the Vendor must provide all necessary releases to obtain information to enable the Purchasing Division Director or the Agency to verify that the Vendor is licensed and in good standing with the above entities.

34. ANTITRUST: In submitting a bid to, signing a contract with, or accepting a Award Document from any agency of the State of West Virginia, the Vendor agrees to convey, sell, assign, or transfer to the State of West Virginia all rights, title, and interest in and to all causes of action it may now or hereafter acquire under the antitrust laws of the United States and the State of West Virginia for price fixing and/or unreasonable restraints of trade relating to the particular commodities or services purchased or acquired by the State of West Virginia. Such assignment shall be made and become effective at the time the purchasing agency tenders the initial payment to Vendor.

35. VENDOR CERTIFICATIONS: By signing its bid or entering into this Contract, Vendor certifies (1) that its bid or offer was made without prior understanding, agreement, or connection with any corporation, firm, limited liability company, partnership, person or entity submitting a bid or offer for the same material, supplies, equipment or services; (2) that its bid or offer is in all respects fair and without collusion or fraud; (3) that this Contract is accepted or entered into without any prior understanding, agreement, or connection to any other entity that could be considered a violation of law; and (4) that it has reviewed this Solicitation in its entirety; understands the requirements, terms and conditions, and other information contained herein.

Vendor's signature on its bid or offer also affirms that neither it nor its representatives have any interest, nor shall acquire any interest, direct or indirect, which would compromise the performance of its services hereunder. Any such interests shall be promptly presented in detail to the Agency. The individual signing this bid or offer on behalf of Vendor certifies that he or she is authorized by the Vendor to execute this bid or offer or any documents related thereto on Vendor's behalf; that he or she is authorized to bind the Vendor in a contractual relationship; and that, to the best of his or her knowledge, the Vendor has properly registered with any State agency that may require registration.

36. VENDOR RELATIONSHIP: The relationship of the Vendor to the State shall be that of an independent contractor and no principal-agent relationship or employer-employee relationship is contemplated or created by this Contract. The Vendor as an independent contractor is solely liable for the acts and omissions of its employees and agents. Vendor shall be responsible for selecting, supervising, and compensating any and all individuals employed pursuant to the terms of this Solicitation and resulting contract. Neither the Vendor, nor any employees or subcontractors of the Vendor, shall be deemed to be employees of the State for any purpose whatsoever. Vendor shall be exclusively responsible for payment of employees and contractors for all wages and salaries, taxes, withholding payments, penalties, fees, fringe benefits, professional liability insurance premiums, contributions to insurance and pension, or other deferred compensation plans, including but not limited to, Workers' Compensation and Social Security obligations, licensing fees, etc. and the filing of all necessary documents, forms, and returns pertinent to all of the foregoing.

Vendor shall hold harmless the State, and shall provide the State and Agency with a defense against any and all claims including, but not limited to, the foregoing payments, withholdings, contributions, taxes, Social Security taxes, and employer income tax returns.

37. INDEMNIFICATION: The Vendor agrees to indemnify, defend, and hold harmless the State and the Agency, their officers, and employees from and against: (1) Any claims or losses for services rendered by any subcontractor, person, or firm performing or supplying services, materials, or supplies in connection with the performance of the Contract; (2) Any claims or losses resulting to any person or entity injured or damaged by the Vendor, its officers, employees, or subcontractors by the publication, translation, reproduction, delivery, performance, use, or disposition of any data used under the Contract in a manner not authorized by the Contract, or by Federal or State statutes or regulations; and (3) Any failure of the Vendor, its officers, employees, or subcontractors to observe State and Federal laws including, but not limited to, labor and wage and hour laws.

38. PURCHASING AFFIDAVIT: In accordance with West Virginia Code § 5-22-1(i), the contracting public entity shall not award a contract for a construction project to any bidder that is known to be in default on any monetary obligation owed to the state or a political subdivision of the state, including, but not limited to, obligations related to payroll taxes, property taxes, sales and use taxes, fire service fees, or other fines or fees. Accordingly, prior to contract award, Vendors are required to sign, notarize, and submit the Purchasing Affidavit to the Purchasing Division affirming under oath that it is not in default on any monetary obligation owed to the state or a political subdivision of the state.

39. ADDITIONAL AGENCY AND LOCAL GOVERNMENT USE: This Contract may be utilized by other agencies, spending units, and political subdivisions of the State of West Virginia; county, municipal, and other local government bodies; and school districts ("Other Government Entities"). Any extension of this Contract to the aforementioned Other Government Entities must be on the same prices, terms, and conditions as those offered and agreed to in this Contract, provided that such extension is in compliance with the applicable laws, rules, and ordinances of the Other Government Entity. If the Vendor does not wish to extend the prices, terms, and conditions of its bid and subsequent contract to the Other Government Entities, the Vendor must clearly indicate such refusal in its bid. A refusal to extend this Contract to the Other Government Entities shall not impact or influence the award of this Contract in any manner.

40. CONFLICT OF INTEREST: Vendor, its officers or members or employees, shall not presently have or acquire an interest, direct or indirect, which would conflict with or compromise the performance of its obligations hereunder. Vendor shall periodically inquire of its officers, members and employees to ensure that a conflict of interest does not arise. Any conflict of interest discovered shall be promptly presented in detail to the Agency.

41. REPORTS: Vendor shall provide the Agency and/or the Purchasing Division with the following reports identified by a checked box below:

Such reports as the Agency and/or the Purchasing Division may request. Requested reports may include, but are not limited to, quantities purchased, agencies utilizing the contract, total contract expenditures by agency, etc.

Quarterly reports detailing the total quantity of purchases in units and dollars, along with a listing of purchases by agency. Quarterly reports should be delivered to the Purchasing Division via email at purchasing.requisitions@wv.gov.

42. BACKGROUND CHECK: In accordance with W. Va. Code § 15-2D-3, the Director of the Division of Protective Services shall require any service provider whose employees are regularly employed on the grounds or in the buildings of the Capitol complex or who have access to sensitive or critical information to submit to a fingerprint-based state and federal background inquiry through the state repository. The service provider is responsible for any costs associated with the fingerprint-based state and federal background inquiry.

After the contract for such services has been approved, but before any such employees are permitted to be on the grounds or in the buildings of the Capitol complex or have access to sensitive or critical information, the service provider shall submit a list of all persons who will be physically present and working at the Capitol complex to the Director of the Division of Protective Services for purposes of verifying compliance with this provision. The State reserves the right to prohibit a service provider's employees from accessing sensitive or critical information or to be present at the Capitol complex based upon results addressed from a criminal background check.

Service providers should contact the West Virginia Division of Protective Services by phone at (304) 558-9911 for more information.

43. PREFERENCE FOR USE OF DOMESTIC STEEL PRODUCTS: Except when authorized by the Director of the Purchasing Division pursuant to W. Va. Code § 5A-3-56, no contractor may use or supply steel products for a State Contract Project other than those steel products made in the United States. A contractor who uses steel products in violation of this section may be subject to civil penalties pursuant to W. Va. Code § 5A-3-56. As used in this section:

- a. "State Contract Project" means any erection or construction of, or any addition to, alteration of or other improvement to any building or structure, including, but not limited to, roads or highways, or the installation of any heating or cooling or ventilating plants or other equipment, or the supply of and materials for such projects, pursuant to a contract with the State of West Virginia for which bids were solicited on or after June 6, 2001.
- b. "Steel Products" means products rolled, formed, shaped, drawn, extruded, forged, cast, fabricated or otherwise similarly processed, or processed by a combination of two or more or such operations, from steel made by the open heath, basic oxygen, electric furnace, Bessemer or other steel making process. The Purchasing Division Director may, in writing, authorize the use of foreign steel products if:
- c. The cost for each contract item used does not exceed one tenth of one percent (.1%) of the total contract cost or two thousand five hundred dollars (\$2,500.00), whichever is greater. For the purposes of this section, the cost is the value of the steel product as delivered to the project; or
- d. The Director of the Purchasing Division determines that specified steel materials are not produced in the United States in sufficient quantity or otherwise are not reasonably available to meet contract requirements.

44. PREFERENCE FOR USE OF DOMESTIC ALUMINUM, GLASS, AND STEEL: In Accordance with W. Va. Code § 5-19-1 et seq., and W. Va. CSR § 148-10-1 et seq., for every contract or subcontract, subject to the limitations contained herein, for the construction, reconstruction, alteration, repair, improvement or maintenance of public works or for the purchase of any item of machinery or equipment to be used at sites of public works, only domestic aluminum, glass or steel products shall be supplied unless the spending officer determines, in writing, after the receipt of offers or bids, (1) that the cost of domestic aluminum, glass or steel products is unreasonable or inconsistent with the public interest of the State of West Virginia, (2) that domestic aluminum, glass or steel products are not produced in sufficient quantities to meet the contract requirements, or (3) the available domestic aluminum, glass, or steel do not meet the contract specifications. This provision only applies to public works contracts awarded in an amount more than fifty thousand dollars (\$50,000) or public works contracts that require more than ten thousand pounds of steel products.

The cost of domestic aluminum, glass, or steel products may be unreasonable if the cost is more than twenty percent (20%) of the bid or offered price for foreign made aluminum, glass, or steel products. If the domestic aluminum, glass or steel products to be supplied or produced in a "substantial labor surplus area", as defined by the United States Department of Labor, the cost of domestic aluminum, glass, or steel products may be unreasonable if the cost is more than thirty percent (30%) of the bid or offered price for foreign made aluminum, glass, or steel products. This preference shall be applied to an item of machinery or equipment, as indicated above, when the item is a single unit of equipment or machinery manufactured primarily of aluminum, glass or steel, is part of a public works contract and has the sole purpose or of being a permanent part of a single public works project. This provision does not apply to equipment or machinery purchased by a spending unit for use by that spending unit and not as part of a single public works project.

All bids and offers including domestic aluminum, glass or steel products that exceed bid or offer prices including foreign aluminum, glass or steel products after application of the preferences provided in this provision may be reduced to a price equal to or lower than the lowest bid or offer price for foreign aluminum, glass or steel products plus the applicable preference. If the reduced bid or offer prices are made in writing and supersede the prior bid or offer prices, all bids or offers, including the reduced bid or offer prices, will be reevaluated in accordance with this rule.

45. INTERESTED PARTY SUPPLEMENTAL DISCLOSURE: W. Va. Code § 6D-1-2 requires that for contracts with an actual or estimated value of at least \$100,000, the vendor must submit to the Agency a supplemental disclosure of interested parties reflecting any new or differing interested parties to the contract, which were not included in the original pre-award interested party disclosure, within 30 days following the completion or termination of the contract. A copy of that form is included with this solicitation or can be obtained from the WV Ethics Commission. "Interested parties" means: (1) A business entity performing work or service pursuant to, or in furtherance of, the applicable contract, including specifically sub-contractors; (2) the person(s) who have an ownership interest equal to or greater than 25% in the business entity performing work or service pursuant to, or in furtherance of, the applicable contract; and (3) the person or business entity, if any, that served as a compensated broker or intermediary to actively facilitate the applicable contract or negotiated the terms of the applicable contract with the state agency: Provided, That subdivision (2) shall be inapplicable if a business entity is a publicly traded company: Provided, however, That subdivision (3) shall not include persons or business entities performing legal services related to the negotiation or drafting of the applicable contract. The Agency shall submit a copy of the disclosure to the Ethics Commission within 15 days after receiving the supplemental disclosure of interested parties.

DESIGNATED CONTACT: Vendor appoints the individual identified in this Section as the Contract Administrator and the initial point of contact for matters relating to this Contract.

Charles Ellis Fleet Mgr.
(Name, Title)
CHARLES ELLIS FLEET MGR.
(Printed Name and Title)
500 FORD FAIRLANE CHAPMANVILLE, WV 25508
(Address)
304-855-8300 304-855-1451
(Phone Number) / (Fax Number)
CELLIS@MAIL.COM
(email address)

CERTIFICATION AND SIGNATURE: By signing below, or submitting documentation through wvOASIS, I certify that I have reviewed this Solicitation in its entirety; that I understand the requirements, terms and conditions, and other information contained herein; that this bid, offer or proposal constitutes an offer to the State that cannot be unilaterally withdrawn; that the product or service proposed meets the mandatory requirements contained in the Solicitation for that product or service, unless otherwise stated herein; that the Vendor accepts the terms and conditions contained in the Solicitation, unless otherwise stated herein; that I am submitting this bid, offer or proposal for review and consideration; that I am authorized by the vendor to execute and submit this bid, offer, or proposal, or any documents related thereto on vendor's behalf; that I am authorized to bind the vendor in a contractual relationship; and that to the best of my knowledge, the vendor has properly registered with any State agency that may require registration.

Thornhill FORD
(Company)
Charles Ellis Fleet Mgr.
(Authorized Signature) (Representative Name, Title)
CHARLES ELLIS FLEET MGR.
(Printed Name and Title of Authorized Representative)
9/26/17
(Date)
304-855-8300 304-855-1451
(Phone Number) (Fax Number)

CRFQ 0803 DOT1800000013
REQUEST FOR QUOTATION
19,000 GVWR 4x4 Crew Cab with Aluminum Closed Top Service Body
(WVDOH 269 Class)

SPECIFICATIONS

1. **PURPOSE AND SCOPE:** The West Virginia Purchasing Division is soliciting bids on behalf of the West Virginia Division of Highways, Department of Transportation to establish an open-end contract for a 19,000 GVWR 4-Wheel Drive Crew Cab Truck with Aluminum Closed Top Service Body.
2. **DEFINITIONS:** The terms listed below shall have the meanings assigned to them below. Additional definitions can be found in section 2 of the General Terms and Conditions.
 - 2.1 **“Contract Item” or “Contract Items”** means the list of items identified in Section 3.1, below and on the Pricing Pages.
 - 2.2 **“Pricing Pages”** means the schedule of prices, estimated order quantity, and totals contained in wvOASIS or attached hereto as Exhibit A, and used to evaluate the Solicitation response.
 - 2.3 **“Solicitation”** means the official notice of an opportunity to supply the State with goods or services that is published by the Purchasing Division.
 - 2.4 **“G.V.W.R”** means gross vehicle weight rating.
 - 2.5 **“WVDOH”** means West Virginia Division of Highways.
 - 2.6 **“PTO”** means power take off.
 - 2.7 **“ABS”** means antilock braking system.
 - 2.8 **“CCA”** means cold cranking amps.
 - 2.9 **“LED”** means Light Emitting Diodes
 - 2.10 **“Class 269”** means a WVDOH internal class designation and has no significance to the specifications of the item being requested.
3. **GENERAL REQUIREMENTS:**
 - 3.1 **Contract Items and Mandatory Requirements:** Vendor shall provide Agency with the Contract Items listed below on an open-end and continuing basis. Contract Items must meet or exceed the mandatory requirements as shown below.

CRFQ 0803 DOT1800000013
REQUEST FOR QUOTATION
19,000 GVWR 4x4 Crew Cab with Aluminum Closed Top Service Body
(WVDOH 269 Class)

3.1.1 Truck Cab/Chassis 4-wheel Drive 4-door Crew Cab.

- 3.1.1.1 The GVWR rating shall be 19,000 Lbs. minimum.
- 3.1.1.2 Cab to Axle Dimension: shall be 84" minimum.
- 3.1.1.3 Must have dual rear wheels.
- 3.1.1.4 The unit specified herein and offered shall be manufactured on or after January 1, 2017 and will be clearly identified and marked with date of manufacture.

3.1.2 Engine

- 3.1.2.1 Must be minimum of 6.7 Liter, liquid cooled, Turbo Diesel engine.
- 3.1.2.2 Engine shall have factory installed Exhaust Brake.
- 3.1.2.3 Engine shall have factory installed engine block heater.
- 3.1.2.4 Engine shall have manufacturer's largest cooling system available.
- 3.1.2.5 Shall have minimum of 220 amp alternator.
- 3.1.2.6 Shall have a minimum of two 750 CCA batteries.
- 3.1.2.7 Engine shall have operator command exhaust filter regeneration manual switch.
- 3.1.2.8 Engine shall have stationary idle control system.

3.1.3 Transmission and Transfer Case

- 3.1.3.1 Shall have Automatic Transmission.
- 3.1.3.2 Transmission shall have PTO prep package.
- 3.1.3.3 Transmission shall have manufacturer's largest external transmission cooler available.

CRFQ 0803 DOT1800000013
REQUEST FOR QUOTATION
19,000 GVWR 4x4 Crew Cab with Aluminum Closed Top Service Body
(WVDOH 269 Class)

3.1.3.4 Electric shift on the go or manual 4x4 transfer case.

3.1.3.5 Shall have OSHA approved back up alarm corrosion resistant.

3.1.4 Cab and Interior Features

3.1.4.1 Cab shall be largest (4) four door crew cab offered by manufacturer.

3.1.4.2 Cab shall have power windows and locks.

3.1.4.3 Shall have heating and air conditioning.

3.1.4.4 Shall have tilt steering column.

3.1.4.5 Shall have integrated electric trailer brake controller.

3.1.4.6 Integrated up-fitter switches minimum of (4) four.

3.1.4.7 Shall have 40/20/40 split vinyl bench seat.

3.1.4.8 Shall have black vinyl floor covering.

3.1.4.9 Shall have AM/FM radio with wireless connectivity.

3.1.4.10 Shall have Left and right side heated mirrors.

3.1.4.11 Shall have license plate mounts front and rear.

3.1.4.12 shall have factory installed front mud flaps and running boards.

3.1.4.13 Minimum of one (1) 12 Volt auxiliary power outlet.

3.1.4.14 Minimum of (1) one factory 115V outlet.

3.1.4.15 One (1) DOT approved roadside safety kit, including 3 reflective triangles, and one (1) DOT approved fire extinguisher.

3.1.4.16 Cab shall have outside temperature display.

3.1.4.17 Cab shall include up-fitter interface module.

CRFQ 0803 DOT1800000013
REQUEST FOR QUOTATION
**19,000 GVWR 4x4 Crew Cab with Aluminum Closed Top Service Body
(WVDOH 269 Class)**

3.1.4.18 Cab shall include factory rear view camera prep package.

3.1.4.19 Cab shall have (1) mounted LED bar light, Truck-Lite Model #92867Y or equal minimum length 46 inches, amps 4.6, voltage 10-30V.

3.1.5 Suspension

3.1.5.1 Shall have front and rear stabilizer bars.

3.1.5.2 Shall have snow plow prep package.

3.1.5.3 Shall have conventional tow capacity of 17,000 lbs. minimum.

3.1.5.4 Shall have six (6) All-Terrain radial tires.

3.1.5.5 Shall have Limited slip rear-end.

3.1.5.6 Rear axle ratio shall be 4:88.

3.1.5.7 Shall have manual 4x4 lock in-out or Automatic front hubs.

3.1.5.8 Shall have Four wheel disc brakes with ABS.

3.1.6 Fuel Tank

3.1.6.1 Fuel tank shall be minimum of 38 gallons.

3.1.7 Paint and General Miscellaneous Items must include:

3.1.7.1 Cab exterior shall be painted PPG paint code #913078 or equal school bus yellow base coat with urethane clear. Cab shall not be painted overtop another finish color.

3.1.7.2 Chassis shall be painted black.

3.1.7.3 Shall have minimum of two (2) front mounted tow hooks.

CRFQ 0803 DOT1800000013
REQUEST FOR QUOTATION
**19,000 GVWR 4x4 Crew Cab with Aluminum Closed Top Service Body
(WVDOH 269 Class)**

3.1.7.4 Shall have full size matching spare tire and wheel with jack.

3.1.8 Aluminum Service Body with Enclosed Top Reading Model # ALTPB72-UR132AHHDW or equal.

3.1.8.1 Body Length shall be minimum 132 inches.

3.1.8.2 Body Width shall be maximum 95 inches.

3.1.8.3 Body Inside Height shall be minimum 72 inches.

3.1.8.4 Body Side compartments shall be minimum of 21.5 inches deep.

3.1.9 Body Compartments:

3.1.9.1 Shall have two (2) adjustable divider shelves, street side front vertical compartment.

3.1.9.2 Shall have curb side front vertical compartment that will accommodate (1) oxygen cylinder, minimum size 51 inches high x 9 inches in diameter and (1) acetylene cylinder minimum size 34 inches high x 8 inches in diameter with hold downs and minimum of (1) one vent and (1) oxygen-acetylene twin hose reel mounted with a minimum of 50' of twin hose reel. Reel Craft Model: TWD 8450OLPT or equal.

3.1.9.3 Shall have one (1) adjustable divider shelf, street and curb side rear vertical compartment.

3.1.9.4 Shall have one (1) adjustable divider shelf, curb side horizontal compartment.

3.1.9.5 Shall have (3) full length shelves, each side in interior of body with adjustable dividers.

3.1.9.6 All compartments shall have stainless steel rotary slam latches on all doors with nitrogen strut door holders on vertical compartments.

3.1.9.7 Shall have double panel rear doors with rivetless latch

CRFQ 0803 DOT1800000013
REQUEST FOR QUOTATION
**19,000 GVWR 4x4 Crew Cab with Aluminum Closed Top Service Body
(WVDOH 269 Class)**

with minimum of one (1) glass window in each door,
with guards.

3.1.9.8 Compartments shall have master locks on both sides with padlocks keyed alike.

3.1.9.9 All body compartment shelving to be galvanized steel.

3.1.10 Body Lighting, Safety Features and Accessories.

3.1.10.1 Body lighting shall be flush mount LED light kit with stop/tail/turn and back up lights with sealed wiring harness, with minimum of two interior LED dome lights.

3.1.10.2 Each Body compartments shall have LED lighting.

3.1.10.3 Right and Left rear of body shall have minimum 1per side flush mounted LED yellow oval strobe lights Truck-Lite model # 92873Y or equal.

3.1.10.3.1 LED

3.1.10.3.2 Black Grommet Mount

3.1.10.3.3 2"x6" common size

3.1.10.3.4 12v hard wired

3.1.10.3.5 Minimum 56 high intensity LEDs w/ 15 flash patterns.

3.1.10.4 Body shall have right and left rear mud flaps.

3.1.10.5 Body shall have minimum of (2) Hella #H71030301 optilux 4" minimum LED work lamps with aluminum housing, 9-LED minimum or equal mounted on rear of body.

3.1.10.6 Body shall have minimum of (2) aluminum top mounted extension ladder racks.

3.1.10.7 Body shall have rear mounted corrosion resistant ladder.

3.1.10.8 Body shall have spare tire mount.

3.1.10.9 Body shall have aluminum treadplate protective guards on front of body.

CRFQ 0803 DOT1800000013
REQUEST FOR QUOTATION
**19,000 GVWR 4x4 Crew Cab with Aluminum Closed Top Service Body
(WVDOH 269 Class)**

3.1.11 Rear Bumper and Hitch:

3.1.11.1 Body shall include slip resistant pooched recessed bumper with 2" square hitch receiver attached to chassis. Bumper shall include safety chain connections and a 7-pole corrosion resistant trailer plug factory wired to chassis light circuit and to the factory electric trailer brake controller. All wiring must be sealed.

3.1.12 Body Paint:

3.1.12.1 Body exterior and body components shall be factory powder coated color PPG# 913078 school bus yellow or equal. Body shall not be painted overtop another finish coat. Interior compartment color shall be manufacturers standard.

3.1.12.2 Bed body shall have complete factory undercoating.

3.1.12.3 Body interior floor and bed sides shall have factory sprayed on bed liner.

3.1.13 Pre-Build Meeting

3.1.13.1 After award of contract there will be a mandatory pre-build meeting with successful vendor, manufacturers and upfitters at The WVDOH/Equipment Division, 83 Brushy Fork Rd. Crossing, Buckhannon, WV.

4. CONTRACT AWARD:

4.1 **Contract Award:** The Contract is intended to provide Agencies with a purchase price on all Contract Items. The Contract shall be awarded to the Vendor that provides the Contract Items meeting the required specifications for the lowest overall total cost as shown on the Pricing Pages.

4.2 **Pricing Pages:** Vendor should complete the Pricing Pages (Exhibit A) by completing the Year, Make, Model and inserting quoted unit price. Vendor shall take estimated Quantity and multiply by Unit Price to get a Grand Total for their bid. Vendor should complete the Pricing Pages in their entirety as failure to do so may result in Vendor's bids being disqualified.

CRFQ 0803 DOT1800000013
REQUEST FOR QUOTATION
**19,000 GVWR 4x4 Crew Cab with Aluminum Closed Top Service Body
(WVDOH 269 Class)**

The Pricing Pages contain a list of the Contract Items and estimated purchase volume. The estimated purchase volume for each item represents the approximate volume of anticipated purchases only. No future use of the Contract or any individual item is guaranteed or implied.

Vendor should electronically enter the information into the Pricing Pages through wvOASIS, if available, or as an electronic document. In most cases, the Vendor can request an electronic copy of the Pricing Pages for bid purposes by sending an email request to the following address: Mark.A.Atkins@wv.gov

5. ORDERING AND PAYMENT:

- 5.1 Ordering:** Vendor shall accept orders through wvOASIS, regular mail, facsimile, e-mail, or any other written form of communication. Vendor may, but is not required to, accept on-line orders through a secure internet ordering portal/website. If Vendor has the ability to accept on-line orders, it should include in its response a brief description of how Agencies may utilize the on-line ordering system. Vendor shall ensure that its on-line ordering system is properly secured prior to processing Agency orders on-line.
- 5.2 Payment:** Vendor shall accept payment in accordance with the payment procedures of the State of West Virginia.

6. DELIVERY AND RETURN:

- 6.1 Delivery Time:** Vendor shall deliver standard orders within **180** working days after orders are received. Vendor shall ship all orders in accordance with the above schedule and shall not hold orders until a minimum delivery quantity is met. A completed pilot model for inspection must be provided within 120 working day(s) after receipt of the purchase agreement by the successful vendor. Working day is defined as any week day, Monday thru Friday, excluding Federal and State Holidays.
- 6.2 Late Delivery:** The Agency placing the order under this Contract must be notified in writing if orders will be delayed for any reason. Any delay in delivery that could cause harm to an Agency will be grounds for cancellation of the delayed order, and/or obtaining the items ordered from a third party.

Any Agency seeking to obtain items from a third party under this provision must first obtain approval of the Purchasing Division.

- 6.3 Delivery Payment/Risk of Loss:** Standard order delivery shall be F.O.B. destination

CRFQ 0803 DOT1800000013
REQUEST FOR QUOTATION
**19,000 GVWR 4x4 Crew Cab with Aluminum Closed Top Service Body
(WVDOH 269 Class)**

to the Agency's location. Vendor shall include the cost of standard order delivery charges in its bid pricing/discount and is not permitted to charge the Agency separately for such delivery.

6.4 Representative Unit for Test: The successful vendor must (if specified) provide the DOH one (1) completed represented unit to be observed and evaluated on each order to insure compliance with specification. If requested, the time period for testing and evaluation shall be seven (7) working days following receipt of the unit. DOH will incur no obligation for deterioration of surfaces, finishes, seals, and mechanical or electrical parts on the unit resulting from operation and testing within the limits of these specifications; nor will DOH incur obligation for damage to the unit resulting from failure to meet specifications when due care and attention is given by WVDOH and testing is done within the limits of these specifications. Failure of the pilot unit to satisfactorily meet specifications as bid may be cause for cancellation of the purchase order, and return of the delivered unit along with all associated equipment to the vendor at the vendor's expense.

6.5 Condition of Unit(s) Upon Delivery: All units must arrive at the prescribed delivery point having been completely pre-serviced with oil, lubricants, and coolant. All prescribed precautions pertaining to first operations and break-in of the unit are to be posted conspicuously on the unit for ready observance by the operator.

6.6 Delivery Point: Delivery point of the completed representative unit will be the WVDOH, Equipment Division, 83 Brushy Fork Crossing, Buckhannon, WV 26201.

7. VENDOR DEFAULT:

7.1 The following shall be considered a vendor default under this Contract.

7.1.1 Failure to provide Contract Items in accordance with the requirements contained herein.

7.1.2 Failure to comply with other specifications and requirements contained herein.

7.1.3 Failure to comply with any laws, rules, and ordinances applicable to the Contract Services provided under this Contract.

7.1.4 Failure to remedy deficient performance upon request.

7.2 The following remedies shall be available to Agency upon default.

7.2.1 Immediate cancellation of the Contract.

CRFQ 0803 DOT1800000013
REQUEST FOR QUOTATION
19,000 GVWR 4x4 Crew Cab with Aluminum Closed Top Service Body
(WVDOH 269 Class)

7.2.2 Immediate cancellation of one or more release orders issued under this Contract.

7.2.3 Any other remedies available in law or equity.

8. MISCELLANEOUS:

8.1 No Substitutions: Vendor shall supply only Contract Items submitted in response to RFQ unless a contract modification is approved in accordance with the provisions contained in this contract.

8.2 Reports: Vendor shall provide quarterly reports and annual summaries to the Agency showing the Agency's items purchased, quantities of items purchased, and total dollar value of the items purchased. Vendor shall also provide reports, upon request, showing the items purchased during the term of this Contract, the quantity purchased for each of those items, and the total value of purchases for each of those items. Failure to supply such reports may be grounds for cancellation of this Contract.

8.3 Contract Manager: During its performance of this Contract, Vendor must designate and maintain a primary contract manager responsible for overseeing Vendor's responsibilities under this Contract. The Contract manager must be available during normal business hours to address any customer service or other issues related to this Contract. Vendor should list its Contract manager and his or her contact information below.

Contract Manager: CHARLES ELLIS
Telephone Number: 304-855-8300
Fax Number: 304-855-1451
Email Address: CEEllis@MAIL.COM

8.4 Operating and Service Manuals and Parts Lists: An operator's manual must be included with each unit upon delivery. A "line sheet" (if applicable) and the "Equipment Preventative Maintenance Questionnaire", (Exhibit "B") must be with pilot unit upon delivery, Attn: Marcia Lee. There must be 12 Service/shop/maintenance manuals and 14 parts manuals; CD-ROM is preferred in lieu of parts manuals. Manuals shall be delivered upon completion of delivery of total units. Failure to do so will delay payment.

CRFQ 0803 DOT1800000013
REQUEST FOR QUOTATION
**19,000 GVWR 4x4 Crew Cab with Aluminum Closed Top Service Body
(WVDOH 269 Class)**

8.5 Training: Manufacturers and/or dealers will be required to stage a thorough seminar on the subjects of Preventative Maintenance, Operator, and Mechanic Training. In order to keep operators and mechanics updated, the successful vendor shall conduct training sessions covering the operation, maintenance, troubleshooting with each purchase order against this open end contract. Manufacturers and/or dealers shall be required to furnish the Training Academy with one (1) Operator's Manual to be shipped direct to

WVDOH
Training Academy
P.O. Box 610
Buckhannon, West Virginia 26201

Training seminar to be held at the WVDOT, Equipment Division, Buckhannon, WV, after receiving the pilot unit.

8.6 Preventative Maintenance & Operator Procedures: Manufacturers and/or dealers will be required to submit to the Equipment Division, in addition to the operating and service manuals, booklets and pamphlets explaining the Preventative Maintenance and Operator Procedures to be used by the operators of this equipment, and must include such things as daily prestart inspection procedure, service schedule, and routine maintenance required, safety precautions, etc. The successful vendor shall furnish all training aids; i.e. videos, projectors as required in conducting the training.

8.7 Unspecified Accessories & Features: All parts, equipment, accessories, materials, design and performance characteristics not specified herein, but which are necessary to provide a complete unit, must be furnished with each unit and required to conform to strength, quality of material, and quality of workmanship to those which are advertised and provided to the market in general by the unit Industry. All parts and accessories advertised and regularly supplied as standard shall be included, except those which would represent duplication of these specified and except those which, by specification, are not to be furnished. All standard safety features, required by Federal and State Law, shall be included.

8.8 Warranty:

8.8.1 Bumper to Bumper

8.8.1.1 3years/36,000 miles bumper to bumper.

CRFQ 0803 DOT1800000013
REQUEST FOR QUOTATION
**19,000 GVWR 4x4 Crew Cab with Aluminum Closed Top Service Body
(WVDOH 269 Class)**

8.8.2 Engine Warranty:

8.8.2.1 5-years/100,000 miles

8.8.3 Engine Emissions Warranty:

8.8.3.1 5-year/100,000 miles

8.8.4 Power Train:

8.8.4.1 5-year/60,000 miles

8.8.5 Corrosion Coverage:

8.8.5.1 5-year, unlimited mileage.

8.8.6 Truck Cab:

8.8.6.1 5-years 100% parts and labor

8.8.7 Truck Service Body:

8.8.7.1 (10) years on the Corrosion- Service Body, Hinges, latches and shelves.

EXHIBIT B

EQUIPMENT PREVENTATIVE MAINTENANCE QUESTIONNAIRE

THIS FORM MUST BE COMPLETED IN ITS ENTIRETY BY SUCCESSFUL BIDDER OR MANUFACTURER'S TECHNICAL REPRESENTATIVE PRIOR TO DELIVERY OF PILOT MODEL TO THE WVDOH.

DESCRIPTION: _____ MAKE: _____

MODEL: _____ YEAR: _____ PURCHASE AMOUNT: _____

ENGINE: MAKE: _____ MODEL: _____ FUEL TYPE: _____

HORSEPOWER: _____ CYLINDER: _____ ENGINE SERIAL: _____

COOLING SYSTEM CAPACITY: _____

BELTS: DESCRIPTION: _____ PART NUMBERS: _____

GVW: _____ AXLE CAPACITY: FRONT: _____ REAR: _____

TIRES: FRONT MAKE & SIZE: _____

REAR MAKE & SIZE: _____

DIMENSIONS OF UNIT: LENGTH: _____ WIDTH: _____ LENGTH: _____

VENDOR CONTACT PERSON: _____ PHONE: _____

PARTS:

BATTERY MAKE: _____ MODEL: _____ CCA: _____
TOP OR SIDE POST: _____ DIMENSIONS: LENGTH _____ WIDTH _____ HEIGHT _____

SPARK PLUGS OR FUEL INJECTORS MAKE: _____ PART # _____
FUEL PUMP OR INJECTION PUMP MAKE: _____ MODEL: _____

ALTERNATOR MAKE: _____ PART #: _____
STARTER MAKE: _____ PART #: _____

TURBO CHARGER MAKE: _____ PART #: _____
TRANS. MAKE: _____ MODEL: _____ PART #: _____

HYDRAULIC PUMP MAKE: _____ MODEL: _____ AUTO/MANUAL: _____

FILTERS	MAKE	PART NO.	LUBRICANT	MANUFACTURER TYPE
OIL	_____	_____	ENGINE	_____
AIR INNER	_____	_____	TRANSMISSION	_____
AIR OUTER	_____	_____	POWER STEERING	_____
FUEL PRIMARY	_____	_____	HYDRAULIC	_____
FUEL SECONDARY	_____	_____	DIFFERENTIALS	_____
COOLANT	_____	_____	BRAKE FLUID	_____
HYDRAULIC	_____	_____	COOLANT	_____
OTHER	_____	_____	OTHER	_____

EXHIBIT_A PRICING PAGE

CRFQ 0803 DOT1800000013

19,000 GVWR 4x4 Crew Cab with Aluminum Closed Top Service Body

Item No.	Description:	Make/Model & Year	Estimated Unit Quantity	Unit Price (each)	Item Total Cost
1	Complete Unit: 4x4 Crew Cab w/Aluminum Closed Top Service Body	2018 FORD F550 WSH	80	\$ 77225. ⁰⁰	\$ 6,178,000. ⁰⁰
Total Bid Cost					\$ 6,178,000. ⁰⁰

Bid will be awarded to the lowest overall bid total.

Vendor: Thornhill Ford

Contact Name: Charles Ellis

Email: CEEllis@MAIL.COM

STATE OF WEST VIRGINIA
Purchasing Division

PURCHASING AFFIDAVIT

CONSTRUCTION CONTRACTS: Under W. Va. Code § 5-22-1(i), the contracting public entity shall not award a construction contract to any bidder that is known to be in default on any monetary obligation owed to the state or a political subdivision of the state, including, but not limited to, obligations related to payroll taxes, property taxes, sales and use taxes, fire service fees, or other fines or fees.

ALL OTHER CONTRACTS: Under W. Va. Code §5A-3-10a, no contract or renewal of any contract may be awarded by the state or any of its political subdivisions to any vendor or prospective vendor when the vendor or prospective vendor or a related party to the vendor or prospective vendor is a debtor and: (1) the debt owed is an amount greater than one thousand dollars in the aggregate; or (2) the debtor is in employer default.

EXCEPTION: The prohibition listed above does not apply where a vendor has contested any tax administered pursuant to chapter eleven of the W. Va. Code, workers' compensation premium, permit fee or environmental fee or assessment and the matter has not become final or where the vendor has entered into a payment plan or agreement and the vendor is not in default of any of the provisions of such plan or agreement.

DEFINITIONS:

"Debt" means any assessment, premium, penalty, fine, tax or other amount of money owed to the state or any of its political subdivisions because of a judgment, fine, permit violation, license assessment, defaulted workers' compensation premium, penalty or other assessment presently delinquent or due and required to be paid to the state or any of its political subdivisions, including any interest or additional penalties accrued thereon.

"Employer default" means having an outstanding balance or liability to the old fund or to the uninsured employers' fund or being in policy default, as defined in W. Va. Code § 23-2c-2, failure to maintain mandatory workers' compensation coverage, or failure to fully meet its obligations as a workers' compensation self-insured employer. An employer is not in employer default if it has entered into a repayment agreement with the Insurance Commissioner and remains in compliance with the obligations under the repayment agreement.

"Related party" means a party, whether an individual, corporation, partnership, association, limited liability company or any other form or business association or other entity whatsoever, related to any vendor by blood, marriage, ownership or contract through which the party has a relationship of ownership or other interest with the vendor so that the party will actually or by effect receive or control a portion of the benefit, profit or other consideration from performance of a vendor contract with the party receiving an amount that meets or exceeds five percent of the total contract amount.

AFFIRMATION: By signing this form, the vendor's authorized signer affirms and acknowledges under penalty of law for false swearing (W. Va. Code §61-5-3) that: (1) for construction contracts, the vendor is not in default on any monetary obligation owed to the state or a political subdivision of the state, and (2) for all other contracts, that neither vendor nor any related party owe a debt as defined above and that neither vendor nor any related party are in employer default as defined above, unless the debt or employer default is permitted under the exception above.

WITNESS THE FOLLOWING SIGNATURE:

Vendor's Name: Thornhill Ford

Authorized Signature: Charles Ellis Date: 9/26/17

State of WV

County of Logan, to-wit:

Taken, subscribed, and sworn to before me this 26th day of Sept, 2017.

My Commission expires 5/10, 2021.

AFFIX SEAL HERE



OFFICIAL SEAL
STATE OF WEST VIRGINIA
NOTARY PUBLIC
Judy Smith
202 Beachwood Estates
Scott Depot, WV 25560
My Commission Expires May 10, 2021

NOTARY PUBLIC Judy Smith
Purchasing Affidavit (Revised 07/07/2017)

State of West Virginia
VENDOR PREFERENCE CERTIFICATE

Certification and application is hereby made for Preference in accordance with **West Virginia Code**, §5A-3-37. (Does not apply to construction contracts). **West Virginia Code**, §5A-3-37, provides an opportunity for qualifying vendors to request (at the time of bid) preference for their residency status. Such preference is an evaluation method only and will be applied only to the cost bid in accordance with the **West Virginia Code**. This certificate for application is to be used to request such preference. The Purchasing Division will make the determination of the Vendor Preference, if applicable.

1. **Application is made for 2.5% vendor preference for the reason checked:**
Bidder is an individual resident vendor and has resided continuously in West Virginia for four (4) years immediately preceding the date of this certification; **or**,
 Bidder is a partnership, association or corporation resident vendor and has maintained its headquarters or principal place of business continuously in West Virginia for four (4) years immediately preceding the date of this certification;
 Bidder is a resident vendor partnership, association, or corporation with at least eighty percent of ownership interest of bidder held by another entity that meets the applicable four year residency requirement; **or**,
 Bidder is a nonresident vendor which has an affiliate or subsidiary which employs a minimum of one hundred state residents and which has maintained its headquarters or principal place of business within West Virginia continuously for the four (4) years immediately preceding the date of this certification; **or**,
2. **Application is made for 2.5% vendor preference for the reason checked:**
Bidder is a resident vendor who certifies that, during the life of the contract, on average at least 75% of the employees working on the project being bid are residents of West Virginia who have resided in the state continuously for the two years immediately preceding submission of this bid; **or**,
3. **Application is made for 2.5% vendor preference for the reason checked:**
Bidder is a nonresident vendor that employs a minimum of one hundred state residents, or a nonresident vendor which has an affiliate or subsidiary which maintains its headquarters or principal place of business within West Virginia and employs a minimum of one hundred state residents, and for purposes of producing or distributing the commodities or completing the project which is the subject of the bidder's bid and continuously over the entire term of the project, on average at least seventy-five percent of the bidder's employees or the bidder's affiliate's or subsidiary's employees are residents of West Virginia who have resided in the state continuously for the two immediately preceding years and the vendor's bid; **or**,
4. **Application is made for 5% vendor preference for the reason checked:**
Bidder meets either the requirement of both subdivisions (1) and (2) or subdivision (1) and (3) as stated above; **or**,
5. **Application is made for 3.5% vendor preference who is a veteran for the reason checked:**
Bidder is an individual resident vendor who is a veteran of the United States armed forces, the reserves or the National Guard and has resided in West Virginia continuously for the four years immediately preceding the date on which the bid is submitted; **or**,
6. **Application is made for 3.5% vendor preference who is a veteran for the reason checked:**
Bidder is a resident vendor who is a veteran of the United States armed forces, the reserves or the National Guard, if, for purposes of producing or distributing the commodities or completing the project which is the subject of the vendor's bid and continuously over the entire term of the project, on average at least seventy-five percent of the vendor's employees are residents of West Virginia who have resided in the state continuously for the two immediately preceding years.
7. **Application is made for preference as a non-resident small, women- and minority-owned business, in accordance with West Virginia Code §5A-3-59 and West Virginia Code of State Rules.**
Bidder has been or expects to be approved prior to contract award by the Purchasing Division as a certified small, women- and minority-owned business.

Bidder understands if the Secretary of Revenue determines that a Bidder receiving preference has failed to continue to meet the requirements for such preference, the Secretary may order the Director of Purchasing to: (a) rescind the contract or purchase order; or (b) assess a penalty against such Bidder in an amount not to exceed 5% of the bid amount and that such penalty will be paid to the contracting agency or deducted from any unpaid balance on the contract or purchase order.

By submission of this certificate, Bidder agrees to disclose any reasonably requested information to the Purchasing Division and authorizes the Department of Revenue to disclose to the Director of Purchasing appropriate information verifying that Bidder has paid the required business taxes, provided that such information does not contain the amounts of taxes paid nor any other information deemed by the Tax Commissioner to be confidential.

Bidder hereby certifies that this certificate is true and accurate in all respects; and that if a contract is issued to Bidder and if anything contained within this certificate changes during the term of the contract, Bidder will notify the Purchasing Division in writing immediately.

Bidder: Thoenhill Ford

Signed: Charles Ellis

Date: 9/26/17

Title: Fleet Mgr.

*Check any combination of preference consideration(s) indicated above, which you are entitled to receive.

West Virginia Ethics Commission



Disclosure of Interested Parties to Contracts

Pursuant to W. Va. Code § 6D-1-2, a state agency may not enter into a contract, or a series of related contracts, that has/have an actual or estimated value of \$100,000 or more until the business entity submits to the contracting state agency a Disclosure of Interested Parties to the applicable contract. In addition, the business entity awarded a contract is obligated to submit a supplemental Disclosure of Interested Parties reflecting any new or differing interested parties to the contract within 30 days following the completion or termination of the applicable contract.

For purposes of complying with these requirements, the following definitions apply:

"Business entity" means any entity recognized by law through which business is conducted, including a sole proprietorship, partnership or corporation.

"Interested party" or "Interested parties" means:

- (1) A business entity performing work or service pursuant to, or in furtherance of, the applicable contract, including specifically sub-contractors;
- (2) the person(s) who have an ownership interest equal to or greater than 25% in the business entity performing work or service pursuant to, or in furtherance of, the applicable contract. (This subdivision does not apply to a publicly traded company); and
- (3) the person or business entity, if any, that served as a compensated broker or intermediary to actively facilitate the applicable contract or negotiated the terms of the applicable contract with the state agency. (This subdivision does not apply to persons or business entities performing legal services related to the negotiation or drafting of the applicable contract.)

"State agency" means a board, commission, office, department or other agency in the executive, judicial or legislative branch of state government, including publicly funded institutions of higher education: Provided, that for purposes of W. Va. Code § 6D-1-2, the West Virginia Investment Management Board shall not be deemed a state agency nor subject to the requirements of that provision.

The contracting business entity must complete this form and submit it to the contracting state agency prior to contract award and to complete another form within 30 days of contract completion or termination.

This form was created by the State of West Virginia Ethics Commission, 210 Brooks Street, Suite 300, Charleston, WV 25301-1804. Telephone: (304)558-0664; fax: (304)558-2169; e-mail: ethics@wv.gov; website: www.ethics.wv.gov.

West Virginia Ethics Commission

Disclosure of Interested Parties to Contracts

Contracting business entity: Thorndill Ford

Address: 500 Ford Fairlane, Chapmanville, WV 25508

Contracting business entity's authorized agent: Charles Ellis

Address: 500 Ford Fairlane Chapmanville WV 25508

Number or title of contract: Fleet Mgr.

Type or description of contract: Fleet/Commercial Mgr.

Governmental agency awarding contract: State of WV.

Names of each Interested Party to the contract known or reasonably anticipated by the contracting business entity (attach additional pages if necessary):

Signature: Charles Ellis Date Signed: 9/26/17

Check here if this is a Supplemental Disclosure.

Verification

State of WV, County of Boone:

I, Charles Ellis, the authorized agent of the contracting business entity listed above, being duly sworn, acknowledges that the Disclosure herein is being made under oath and under the penalty of perjury.

Subscribed before me this 26th day of Sept, 2017



STATE OF WEST VIRGINIA
NOTARY PUBLIC
Judy Smith
202 Beachwood Estates
Scott Depot, WV 25560
My Commission Expires May 10, 2021

Judy Smith
Notary Public's Signature

To be completed by State Agency:

Date Received by State Agency: _____

Date submitted to Ethics Commission: _____

Governmental agency submitting Disclosure: _____



Thornhill Ford Lincoln
 U.S. Route 119 North, Chapmanville, West Virginia, 25508
 Office: 304-855-8300

2017 F-550 Chassis, SD Crew Cab
 4x4 SD Crew Cab 203" WB DRW XL(W5H)
 Price Level: 755 Quote ID: DOHCrew550

Major Equipment

(Based on selected options, shown at right)

Powerstroke 6.7L V-8 OHV w/diesel direct injection 330hp

TorqShift 6 speed automatic w/OD

- * 4-wheel ABS
- * Traction control
- * LT 225/70R19.5 G BSW AT S-rated rear tires
- * Firm suspension
- * Tinted glass
- * Bluetooth wireless streaming
- * Dual power remote heated mirrors
- * 19.5 x 6 steel wheels
- * Driver and front passenger seat mounted side airbags
- * Tachometer
- * Underseat ducts
- * 60-40 folding rear split-bench
- * Side steps
- * Front axle capacity: 7000 lbs.
- * Front spring rating: 7000 lbs.
- * Frame section modulus: 17.2 cu.in.
- * Cab to axle: 84"
- * Transmission PTO Provision

Interior:Medium Earth Gray

- * Brake assistance
- * LT 225/70R19.5 G BSW AS S-rated front tires
- * Battery with run down protection
- * Air conditioning
- * Radio grade AM/FM stereo with seek-scan, single in-dash CD player, MP3 decoder, auxiliary audio input, external memory control
- * Daytime running
- * Variable intermittent wipers
- * Dual front airbags
- * SecurILock immobilizer
- * Message Center
- * Reclining front split-bench seats
- * Vinyl seats
- * Audio control on steering wheel
- * Rear axle capacity: 14706 lbs.
- * Rear spring rating: 15000 lbs.
- * Frame Yield Strength 50000 psi
- * Axle to end of frame: 47.2"
- * Engine retarder

Fuel Economy

Selected Options

MSRP

STANDARD VEHICLE PRICE	\$45,495.00
Order Code 660A	N/C
Monotone Paint Application	STD
203" Wheelbase	STD
50-State Emissions System	STD
Engine: 6.7L 4V OHV Power Stroke V8 Turbo Diesel B20	\$8,685.00
Transmission: TorqShift 6-Speed Automatic	N/C
Limited Slip w/4.88 Axle Ratio	\$360.00
GVWR: 19,500 lb Payload Plus Upgrade Package	\$1,155.00
Tires: 225/70Rx19.5G BSW Traction	\$190.00
Power Equipment Group	\$1,125.00
Snow Plow Prep Package	\$85.00
Spare Tire, Wheel & Jack	\$350.00
Engine Block Heater	\$90.00
Transmission Power Take-Off Provision	\$280.00
Operator Commanded Regeneration (OCR)	\$250.00
Upfitter Interface Module	\$295.00
Trailer Brake Controller	\$270.00
Platform Running Boards	\$445.00
Rear View Camera & Prep Kit	\$415.00

Prices and content availability as shown are subject to change and should be treated as estimates only. Actual base vehicle, package and option pricing may vary from this estimate because of special local pricing, availability or pricing adjustments not reflected in the dealer's computer system. See salesperson for the most current information.

Prepared for: STATE OF WV
 By: CHARLES ELLIS Date: 09/28/2017



Thornhill Ford Lincoln
 U.S. Route 119 North, Chapmanville, West Virginia, 25508
 Office: 304-855-8300

2017 F-550 Chassis, SD Crew Cab
 4x4 SD Crew Cab 203 WB DRW XL(W5H)
 Price Level: Quote ID: DOHCrew550

City
N/A



Hwy
N/A

110V/400W Outlet	\$75.00
Exterior Backup Alarm (Pre-Installed)	\$140.00
SYNC Communications & Entertainment System	\$365.00
Radio: AM/FM Stereo/Single-CD/MP3 (LPO) (Fleet)	\$275.00
Priced DORA	N/C
Medium Earth Gray	N/C
Wheels: 19.5" Argent Painted Steel	Included
HD Vinyl 40/20/40 Split Bench Seat	Included
Dual 78-AH 750 CCA Batteries	Included
Accessory Delay	Included
Trailer Tow Mirrors w/Power Heated Glass	Included
MyKey	Included
Perimeter Anti-Theft Alarm	Included
Power Front & Rear Side Windows	Included
Power Locks	Included
Remote Keyless Entry	Included
SecuriLock Passive Anti-Theft System (PATS)	Included
Dual Alternators (Total 332-Amps)	Included
6-Ton Hydraulic Jack	Included
<hr/>	
SUBTOTAL	\$60,345.00
Destination Charge	\$1,295.00

Prices and content availability as shown are subject to change and should be treated as estimates only. Actual base vehicle, package and option pricing may vary from this estimate because of special local pricing, availability or pricing adjustments not reflected in the dealer's computer system. See salesperson for the most current information.

Prepared for: STATE OF WV
 By: CHARLES ELLIS Date: 09/25/2017



Thornhill Ford Lincoln
U.S. Route 119 North, Chapmanville, West Virginia, 25508
Office: 304-855-8300

2017 F-550 Chassis, SD Crew Cab
4x4 SD Crew Cab 203" WB DRW XL(W5H)
Price Level: 755 Quote ID: DOHCrew550

TOTAL	\$61,640.00
--------------	--------------------

Prices and content availability as shown are subject to change and should be treated as estimates only. Actual base vehicle, package and option pricing may vary from this estimate because of special local pricing, availability or pricing adjustments not reflected in the dealer's computer system. See salesperson for the most current information.

Prepared for: STATE OF WV
By: CHARLES ELLIS Date: 09/25/2017



Selected Equipment & Specs

Dimensions

- * Exterior length: 289.2"
- * Exterior width: 80.0"
- * Wheelbase: 203.0"
- * Rear track: 74.0"
- * Min ground clearance: 8.2"
- * Rear legroom: 43.6"
- * Rear headroom: 40.4"
- * Rear hiproom: 64.7"
- * Rear shoulder room: 65.9"
- * Cargo volume: 52.1cu.ft.
- * Cab to axle: 84.0"
- * Exterior height: 81.7"
- * Front track: 74.8"
- * Turning radius: 28.6'
- * Front legroom: 43.9"
- * Front headroom: 40.8"
- * Front hiproom: 62.5"
- * Front shoulder room: 66.7"
- * Passenger volume: 131.7cu.ft.
- * Maximum cargo volume: 52.1cu.ft.

Powertrain

- * Powerstroke 330hp 6.7L OHV 32 valve intercooled turbo V-8 engine with diesel direct injection federal
- * Part-time
- * Fuel Economy Cty: N/A
- * Transmission PTO provision
- * Recommended fuel : diesel
- * TorqShift 6 speed automatic transmission with overdrive
- * Limited slip differential
- * Fuel Economy Highway: N/A

Suspension/Handling

- * Front Mono-beam non-independent suspension with anti-roll bar, HD shocks
- * Firm ride Suspension
- * Front and rear 19.5 x 6 argent steel wheels
- * Dual rear wheels
- * Rear DANA 130 rigid axle leaf spring suspension with anti-roll bar, HD shocks
- * Hydraulic power-assist re-circulating ball Steering
- * Front LT225/70SR19.5 GBSW AS rear LT225/70SR19.5 G BSW AT

Body Exterior

- * 4 doors
- * Conventional right rear passenger
- * Turn signal indicator in mirrors
- * Black bumpers
- * Trailer harness
- * Front and rear 19.5 x 6 wheels
- * Conventional left rear passenger
- * Driver and passenger power remote heated folding door mirrors with turn signal indicator
- * Black door mirrors
- * Side steps
- * Clearcoat paint

Convenience

- * Manual air conditioning with air filter
- * Driver and passenger 1-touch up
- * Remote power door locks with 2 stage unlock and illuminated entry
- * Manual telescopic steering wheel
- * 911 Assist emergency S.O.S
- * AppLink smart device integration
- * Front cupholders
- * Full overhead console
- * Rear door bins
- * Power windows
- * Driver and passenger 1-touch down
- * Manual tilt steering wheel
- * Day-night rearview mirror with auto-dimming
- * Wireless phone connectivity
- * 2 1st row LCD monitors
- * Passenger visor mirror
- * Driver and passenger door bins

Seats and Trim

- * Seating capacity of 6
- * Front 40-20-40 split-bench seat

Prices and content availability as shown are subject to change and should be treated as estimates only. Actual base vehicle, package and option pricing may vary from this estimate because of special local pricing, availability or pricing adjustments not reflected in the dealer's computer system. See salesperson for the most current information.



Selected Equipment & Specs (cont'd)

- * 4-way driver seat adjustment
- * 4-way passenger seat adjustment
- * 60-40 folding rear split-bench seat

- * Manual driver lumbar support
- * Centre front armrest with storage

Entertainment Features

- * AM/FM stereo radio with radio data system
- * MP3 decoder
- * SYNC external memory control
- * 6 speakers
- * Fixed antenna

- * Single CD player
- * Auxiliary audio input
- * Steering wheel mounted radio controls
- * Wireless streaming

Lighting, Visibility and Instrumentation

- * Halogen aero-composite headlights
- * Fully automatic headlights
- * Light tinted windows
- * Tachometer
- * Outside temperature display
- * Trip computer

- * Delay-off headlights
- * Variable intermittent front windshield wipers
- * Front and rear reading lights
- * Compass
- * Camera(s) - rear
- * Trip odometer

Safety and Security

- * 4-wheel ABS brakes
- * 4-wheel disc brakes
- * Dual front impact airbag supplemental restraint system
- * Safety Canopy System curtain 1st and 2nd row overhead airbag supplemental restraint system
- * Power remote door locks with 2 stage unlock and panic alarm
- * MyKey restricted driving mode
- * 3 manually adjustable rear head restraints

- * Brake assist
- * Driveline traction control
- * Dual seat mounted side impact airbag supplemental restraint system
- * Remote activated perimeter/approach lighting
- * Security system with SecuriLock immobilizer
- * Manually adjustable front head restraints

Dimensions

General Weights

Curb	8662 lbs.	GVWR	19500 lbs.
Front GAWR	7000 lbs.	Rear GAWR	14706 lbs.
Payload	11060 lbs.	Front curb weight	5099 lbs.
Rear curb weight	3563 lbs.	Front axle capacity	7000 lbs.
Rear axle capacity	14706 lbs.	Front spring rating	7000 lbs.
Rear spring rating	15000 lbs.	Front tire/wheel capacity	7500 lbs.
Rear tire/wheel capacity	15000 lbs.		

Trailer Type

Harness	Yes	Brake controller	Yes
Trailer sway control	Yes		

General Trailing

5th-wheel towing capacity	21700 lbs.	Towing capacity	18500 lbs.
GCWR	31000 lbs.		

Fuel Tank type

Capacity	40 gal.
----------	---------

Off Road

Min ground clearance	8 "
----------------------	-----

Prices and content availability as shown are subject to change and should be treated as estimates only. Actual base vehicle, package and option pricing may vary from this estimate because of special local pricing, availability or pricing adjustments not reflected in the dealer's computer system. See salesperson for the most current information.



Selected Equipment & Specs (cont'd)

Interior cargo
 Cargo volume 52.1 cu.ft. Maximum cargo volume 52.1 cu.ft.

Rear Frame
 Height loaded 29 " Height unloaded 34 "

Powertrain

Engine Type

Brand	Powerstroke	Block material	Iron
Cylinders	V-8	Head material	Aluminum
Ignition	Compression	Injection	Diesel direct injection
Liters	6.7L	Orientation	Longitudinal
Recommended fuel	Diesel	Valves per cylinder	4
Valvetrain	OHV	Forced induction	Intercooled turbo

Engine Spec

Bore	3.90"	Compression ratio	16.2:1
Displacement	406 cu.in.	Stroke	4.25"

Engine Power

Output	330 HP @ 2,600 RPM	Torque	750 ft.-lb @ 2,000 RPM
--------	--------------------	--------	------------------------

Alternator

Type	Dual	Amps	332
------	------	------	-----

Battery

Amp hours	78	Cold cranking amps	750
Run down protection	Yes	Type	Dual

Engine Extras

Block heater	Yes
--------------	-----

Transmission

Electronic control	Yes	Lock-up	Yes
Overdrive	Yes	Speed	6
Type	Automatic		

Transmission Gear Ratios

1st	3.974	2nd	2.318
3rd	1.516	4th	1.149
5th	0.858	6th	0.674
Reverse Gear ratios	3.128		

Transmission Torque Converter

Stall ratio	1.90
-------------	------

Transmission Extras

Driver selectable mode	Yes	Sequential shift control	SelectShift
PTO provision	Yes		

Drive Type

4wd type	Part-time	Type	Four-wheel
----------	-----------	------	------------

Drive Feature

Limited slip differential	Mechanical	Traction control	Driveline
Power take-off provision	Yes	Locking hub control	Manual

Prices and content availability as shown are subject to change and should be treated as estimates only. Actual base vehicle, package and option pricing may vary from this estimate because of special local pricing, availability or pricing adjustments not reflected in the dealer's computer system. See salesperson for the most current information.



Selected Equipment & Specs (cont'd)

Transfer case shift	Manual		
Drive Axle			
Ratio	4.88		
Exhaust			
Material	Stainless steel	System type	Single
Emissions			
CARB	Federal	EPA	Tier 2 Bin 8
fuel Economy			
Fuel type	Diesel		
Engine Retarder			
Type	Yes		
Driveability			
Brakes			
ABS Type	4-wheel 4-wheel disc	ABS channels Vented discs	3 Front and rear
Brake Assistance			
Brake assist	Yes		
Suspension Control			
Ride	Firm		
Front Suspension			
Independence	Mono-beam non-independent	Anti-roll bar	Regular
Front Spring			
Type	Coil	Grade	HD
Front Shocks			
Type	HD		
Rear Suspension			
Independence	DANA 130 rigid axle	Type	Leaf
Anti-roll bar	Regular		
Rear Spring			
Type	Leaf	Grade	HD
Rear Shocks			
Type	HD		
Steering			
Activation	Hydraulic power-assist	Type	Re-circulating ball
Steering Specs			
# of wheels	2		
Exterior			
Front Wheels			
Diameter	19.5"	Width	6.00"

Prices and content availability as shown are subject to change and should be treated as estimates only. Actual base vehicle, package and option pricing may vary from this estimate because of special local pricing, availability or pricing adjustments not reflected in the dealer's computer system. See salesperson for the most current information.



Selected Equipment & Specs (cont'd)

Rear Wheels

Diameter	19.5"	Width	6.00"
Dual	Yes		

Spare Wheels

Wheel material	Steel
----------------	-------

Front and Rear Wheels

Appearance	Argent	Material	Steel
------------	--------	----------	-------

Front Tires

Aspect	70	Diameter	19.5"
Sidewalls	BSW	Speed	S
Tread	AS	Type	LT
Width	225mm	LT load rating	G
RPM	647		

Rear Tires

Aspect	70	Diameter	19.5"
Sidewalls	BSW	Speed	S
Tread	AT	Type	LT
Width	225mm	LT load rating	G
RPM	645		

Spare Tire

Mount	Frame mounted	Type	Full-size
-------	---------------	------	-----------

Wheels

Front track	74.8"	Rear track	74.0"
Turning radius	28.6'	Wheelbase	203.0"

Body Features

Front license plate bracket	Yes	Front splash guards	Yes
Body material	Aluminum	Side impact beams	Yes
Side steps	Yes		

Body Doors

Door count	4	Left rear passenger	Conventional
Right rear passenger	Conventional		

Exterior Dimensions

Length	289.2"	Body width	80.0"
Body height	81.7"	Cab to axle	84.0"
Axle to end of frame	47.2"	Frame section modulus	17.2cu.in.
Frame yield strength (psi)	50000.0	Frame rail width	34.2"
Front bumper to Front axle	38.3"	Cab to end of frame	131.2"
Front bumper to back of cab	158.1"		

Safety

Airbags

Driver front-impact	Yes	Driver side-impact	Seat mounted
Overhead Safety Canopy System curtain 1st and 2nd row		Passenger front-impact	Yes
Passenger side-impact	Seat mounted		

Prices and content availability as shown are subject to change and should be treated as estimates only. Actual base vehicle, package and option pricing may vary from this estimate because of special local pricing, availability or pricing adjustments not reflected in the dealer's computer system. See salesperson for the most current information.



Selected Equipment & Specs (cont'd)

Seatbelt			
Height adjustable	Front		
Security			
Immobilizer	SecuriLock	Panic alarm	Yes
Restricted driving mode	MyKey		
Seating			
Passenger Capacity			
Capacity	6		
Front Seats			
Split	40-20-40	Type	Split-bench
Driver Seat			
Fore/aft	Manual	Reclining	Manual
Way direction control	4	Lumbar support	Manual
Passenger seat			
Fore/aft	Manual	Reclining	Manual
Way direction control	4		
Front Head Restraint			
Control	Manual	Type	Adjustable
Front Armrest			
Centre	Yes	Storage	Yes
Rear Seats			
Descriptor	Split-bench	Facing	Front
Folding	60-40	Folding position	Fold-up cushion
Type	Fixed		
Rear Head Restraints			
Control	Manual	Type	Adjustable
Number	3		
Front Seat Trim			
Material	Vinyl	Back material	Vinyl
Rear Seat Trim Group			
Material	Vinyl	Back material	Carpet
Convenience			
AC And Heat Type			
Air conditioning	Manual	Air filter	Yes
Underseat ducts	Yes		
Audio System			
CD	Single	CD location	In-dash
MP3 decoder	MP3 decoder	Auxiliary audio input	Yes
Radio	AM/FM stereo	Radio data system	Yes
Radio grade	Premium	Seek-scan	Yes
External memory control	SYNC		

Prices and content availability as shown are subject to change and should be treated as estimates only. Actual base vehicle, package and option pricing may vary from this estimate because of special local pricing, availability or pricing adjustments not reflected in the dealer's computer system. See salesperson for the most current information.



Selected Equipment & Specs (cont'd)

Audio Speakers			
Speaker type	Regular	Speakers	6
Audio Controls			
Speed sensitive volume	Yes	Steering wheel controls	Yes
Voice activation	Yes	Wireless streaming	Bluetooth yes
Audio Antenna			
Type	Fixed		
LCD Monitors			
1st row	2	Primary monitor size (inches)	4.2
Convenience Features			
Retained accessory power	Yes	12V DC power outlet	2
Emergency S.O.S	911 Assist	Wireless phone connectivity	Bluetooth
AC power outlet	1	Back-up alarm	Yes
Smart device integration	App link		
Door Lock Activation			
Type	Power with 2 stage unlock	Remote	Keyfob (all doors)
Integrated key/remote	Yes		
Instrumentation Type			
Display	Analog		
Instrumentation Gauges			
Tachometer	Yes	Engine temperature	Yes
Turbo/supercharger boost	Yes	Transmission fluid temp	Yes
Engine hour meter	Yes		
Instrumentation Warnings			
Oil pressure	Yes	Engine temperature	Yes
Battery	Yes	Lights on	Yes
Key	Yes	Low fuel	Yes
Door ajar	Yes	Service interval	Yes
Brake fluid	Yes		
Instrumentation Displays			
Clock	In-radio display	Compass	Yes
Exterior temp	Yes	Systems monitor	Yes
Camera(s) - rear	Yes		
Instrumentation Feature			
Trip computer	Yes	Trip odometer	Yes
Steering Wheel Type			
Material	Urethane	Tilting	Manual
Telescoping	Manual		
Front Side Windows			
Window 1st row activation	Power		
Windows Rear Side			
2nd row activation	Power		
Window Features			

Prices and content availability as shown are subject to change and should be treated as estimates only. Actual base vehicle, package and option pricing may vary from this estimate because of special local pricing, availability or pricing adjustments not reflected in the dealer's computer system. See salesperson for the most current information.



Selected Equipment & Specs (cont'd)

1-touch down Tinted	Driver and passenger Light	1-touch up	Driver and passenger
<i>Front Windshield</i>			
Wiper	Variable intermittent		
<i>Rear Windshield</i>			
Window	Fixed		
Interior			
<i>Passenger Visor</i>			
Mirror	Yes		
<i>Rear View Mirror</i>			
Day-night	Yes	Auto-dimming	Yes
<i>Headliner</i>			
Coverage	Full	Material	Cloth
<i>Floor Trim</i>			
Coverage	Full	Covering	Vinyl/rubber
<i>Trim Feature</i>			
Gear shift knob	Urethane	Interior accents	Chrome
<i>Lighting</i>			
Dome light type	Fade	Front reading	Yes
Illuminated entry	Yes	Rear reading	Yes
Variable IP lighting	Yes		
<i>Overhead Console Storage</i>			
Storage	Yes	Type	Full
<i>Storage</i>			
Driver door bin	Yes	Front Beverage holder(s)	Yes
Glove box	Locking	Passenger door bin	Yes
Illuminated	Yes	instrument panel	Bin
Dashboard	Covered	Rear door bins	Yes
<i>Legroom</i>			
Front	43.9"	Rear	43.6"
<i>Headroom</i>			
Front	40.8"	Rear	40.4"
<i>Hip Room</i>			
Front	62.5"	Rear	64.7"
<i>Shoulder Room</i>			
Front	66.7"	Rear	65.9"
<i>Interior Volume</i>			
Passenger volume	131.7 cu.ft.		

Prices and content availability as shown are subject to change and should be treated as estimates only. Actual base vehicle, package and option pricing may vary from this estimate because of special local pricing, availability or pricing adjustments not reflected in the dealer's computer system. See salesperson for the most current information.

Prepared for: STATE OF WV
 By: CHARLES ELLIS Date: 09/25/2017



Standard Equipment & Specs

Dimensions

- * Exterior length: 289.2"
- * Exterior width: 80.0"
- * Wheelbase: 203.0"
- * Rear track: 74.0"
- * Min ground clearance: 8.2"
- * Rear legroom: 43.6"
- * Rear headroom: 40.4"
- * Rear hiproom: 64.7"
- * Rear shoulder room: 65.9"
- * Cargo volume: 52.1cu.ft.
- * Cab to axle: 84.0"
- * Exterior height: 81.7"
- * Front track: 74.8"
- * Turning radius: 28.6'
- * Front legroom: 43.9"
- * Front headroom: 40.8"
- * Front hiproom: 62.5"
- * Front shoulder room: 66.7"
- * Passenger volume: 131.7cu.ft.
- * Maximum cargo volume: 52.1cu.ft.

Powertrain

- * 288hp 6.8L SOHC 30 valve V-10 engine with SMPI
- * federal
- * Part-time
- * Fuel Economy Highway: N/A
- * Recommended fuel : regular unleaded
- * TorqShift 6 speed automatic transmission with overdrive
- * Fuel Economy Cty: N/A

Suspension/Handling

- * Front Mono-beam non-independent suspension with anti-roll bar, HD shocks
- * Firm ride Suspension
- * Front and rear 19.5 x 6 argent steel wheels
- * Dual rear wheels
- * Rear DANA M300 rigid axle leaf spring suspension with anti-roll bar, HD shocks
- * Hydraulic power-assist re-circulating ball Steering
- * LT225/70SR19.5 GBSW AS front and rear tires

Body Exterior

- * 4 doors
- * Conventional right rear passenger
- * Black door mirrors
- * Trailer harness
- * Front and rear 19.5 x 6 wheels
- * Conventional left rear passenger
- * Driver and passenger folding door mirrors
- * Black bumpers
- * Clearcoat paint

Convenience

- * Manual air conditioning with air filter
- * Manual door locks
- * Manual telescopic steering wheel
- * 1 1st row LCD monitor
- * Passenger visor mirror
- * Manual windows
- * Manual tilt steering wheel
- * Day-night rearview mirror
- * Front cupholders
- * Full overhead console

Seats and Trim

- * Seating capacity of 6
- * 4-way driver seat adjustment
- * 4-way passenger seat adjustment
- * 60-40 folding rear split-bench seat
- * Front 40-20-40 split-bench seat
- * Manual driver lumbar support
- * Centre front armrest with storage

Entertainment Features

- * AM/FM stereo radio
- * Fixed antenna
- * 6 speakers

Prices and content availability as shown are subject to change and should be treated as estimates only. Actual base vehicle, package and option pricing may vary from this estimate because of special local pricing, availability or pricing adjustments not reflected in the dealer's computer system. See salesperson for the most current information.



Standard Equipment & Specs (cont'd)

Lighting, Visibility and Instrumentation

- * Halogen aero-composite headlights
- * Fully automatic headlights
- * Light tinted windows
- * Tachometer
- * Outside temperature display
- * Trip odometer
- * Delay-off headlights
- * Variable intermittent front windshield wipers
- * Front and rear reading lights
- * Oil pressure gauge
- * Trip computer

Safety and Security

- * 4-wheel ABS brakes
- * 4-wheel disc brakes
- * Dual front impact airbag supplemental restraint system
- * Safety Canopy System curtain 1st and 2nd row overhead airbag supplemental restraint system
- * Manually adjustable front head restraints
- * Brake assist
- * Driveline traction control
- * Dual seat mounted side impact airbag supplemental restraint system
- * Manual door locks
- * 3 manually adjustable rear head restraints

Dimensions

General Weights

Curb	7481 lbs.	GVWR	18000 lbs.
Front GAWR	6000 lbs.	Rear GAWR	13660 lbs.
Payload	10510 lbs.	Front curb weight	4319 lbs.
Rear curb weight	3162 lbs.	Front axle capacity	7000 lbs.
Rear axle capacity	13660 lbs.	Front spring rating	6000 lbs.
Rear spring rating	13660 lbs.	Front tire/wheel capacity	7500 lbs.
Rear tire/wheel capacity	15000 lbs.		

Trailer Type

Harness	Yes	Trailer sway control	Yes
---------	-----	----------------------	-----

General Trailering

5th-wheel towing capacity	19600 lbs.	Towing capacity	18500 lbs.
GCWR	28000 lbs.		

Fuel Tank type

Capacity	40 gal.
----------	---------

Off Road

Min ground clearance	8 "
----------------------	-----

Interior cargo

Cargo volume	52.1 cu.ft.	Maximum cargo volume	52.1 cu.ft.
--------------	-------------	----------------------	-------------

Rear Frame

Height loaded	29 "	Height unloaded	34 "
---------------	------	-----------------	------

Powertrain

Engine Type

Block material	Iron	Cylinders	V-10
Head material	Aluminum	Ignition	Electronic
Injection	Sequential MPI	Liters	6.8L
Orientation	Longitudinal	Recommended fuel	Regular unleaded
Valves per cylinder	3	Valvetrain	SOHC

Prices and content availability as shown are subject to change and should be treated as estimates only. Actual base vehicle, package and option pricing may vary from this estimate because of special local pricing, availability or pricing adjustments not reflected in the dealer's computer system. See salesperson for the most current information.



Standard Equipment & Specs (cont'd)

Engine Spec

Bore	3.55"	Compression ratio	9.2:1
Displacement	415 cu.in.	Stroke	4.16"

Engine Power

Output	288 HP @ 4,000 RPM	Torque	424 ft.-lb @ 3,000 RPM
--------	--------------------	--------	------------------------

Alternator

Type	HD	Amps	240
------	----	------	-----

Battery

Amp hours	78	Cold cranking amps	750
Run down protection	Yes	Type	HD

Transmission

Electronic control	Yes	Lock-up	Yes
Overdrive	Yes	Speed	6
Type	Automatic		

Transmission Gear Ratios

1st	3.974	2nd	2.318
3rd	1.516	4th	1.149
5th	0.858	6th	0.674
Reverse Gear ratios	3.128		

Transmission Torque Converter

Stall ratio	1.90
-------------	------

Transmission Extras

Driver selectable mode	Yes	Sequential shift control	SelectShift
Oil cooler	Regular duty		

Drive Type

4wd type	Part-time	Type	Four-wheel
----------	-----------	------	------------

Drive Feature

Traction control	Driveline	Locking hub control	Manual
Transfer case shift	Manual		

Drive Axle

Ratio	4.88
-------	------

Exhaust

Material	Stainless steel	System type	Single
----------	-----------------	-------------	--------

Emissions

CARB	Federal	EPA	Tier 2 Bin 8
------	---------	-----	--------------

Fuel Economy

Fuel type	Gasoline
-----------	----------

Driveability

Brakes

ABS	4-wheel	ABS channels	3
Type	4-wheel disc	Vented discs	Front and rear

Prices and content availability as shown are subject to change and should be treated as estimates only. Actual base vehicle, package and option pricing may vary from this estimate because of special local pricing, availability or pricing adjustments not reflected in the dealer's computer system. See salesperson for the most current information.



Standard Equipment & Specs (cont'd)

Brake Assistance

Brake assist Yes

Suspension Control

Ride Firm

Front Suspension

Independence Mono-beam non-independent Anti-roll bar Regular

Front Spring

Type Coil Grade Regular

Front Shocks

Type HD

Rear Suspension

Independence DANA M300 rigid axle Type Leaf
 Anti-roll bar Regular

Rear Spring

Type Leaf Grade HD

Rear Shocks

Type HD

Steering

Activation Hydraulic power-assist Type Re-circulating ball

Steering Specs

of wheels 2

Exterior

Front Wheels

Diameter 19.5" Width 6.00"

Rear Wheels

Diameter 19.5" Width 6.00"
 Dual Yes

Front and Rear Wheels

Appearance Argent Material Steel

Front Tires

Aspect 70 Diameter 19.5"
 Sidewalls BSW Speed S
 Tread AS Type LT
 Width 225mm LT load rating G
 RPM 647

Rear Tires

Aspect 70 Diameter 19.5"
 Sidewalls BSW Speed S
 Tread AS Type LT
 Width 225mm LT load rating G
 RPM 647

Prices and content availability as shown are subject to change and should be treated as estimates only. Actual base vehicle, package and option pricing may vary from this estimate because of special local pricing, availability or pricing adjustments not reflected in the dealer's computer system. See salesperson for the most current information.



Standard Equipment & Specs (cont'd)

Wheels

Front track	74.8"	Rear track	74.0"
Turning radius	28.6'	Wheelbase	203.0"

Body Features

Front license plate bracket	Yes	Front splash guards	Yes
Body material	Aluminum	Side impact beams	Yes

Body Doors

Door count	4	Left rear passenger	Conventional
Right rear passenger	Conventional		

Exterior Dimensions

Length	289.2"	Body width	80.0"
Body height	81.7"	Cab to axle	84.0"
Axle to end of frame	47.2"	Frame section modulus	12.7cu.in.
Frame yield strength (psi)	50000.0	Frame rail width	34.2"
Front bumper to Front axle	38.3"	Cab to end of frame	131.2"
Front bumper to back of cab	158.1"		

Safety

Airbags

Driver front-impact	Yes	Driver side-impact	Seat mounted
Overhead Safety Canopy System curtain 1st and 2nd row		Passenger front-impact	Yes
Passenger side-impact	Seat mounted		

Seatbelt

Height adjustable	Front
-------------------	-------

Seating

Passenger Capacity

Capacity	6
----------	---

Front Seats

Split	40-20-40	Type	Split-bench
-------	----------	------	-------------

Driver Seat

Fore/aft	Manual	Reclining	Manual
Way direction control	4	Lumbar support	Manual

Passenger seat

Fore/aft	Manual	Reclining	Manual
Way direction control	4		

Front Head Restraint

Control	Manual	Type	Adjustable
---------	--------	------	------------

Front Armrest

Centre	Yes	Storage	Yes
--------	-----	---------	-----

Rear Seats

Descriptor	Split-bench	Facing	Front
Folding	60-40	Folding position	Fold-up cushion

Prices and content availability as shown are subject to change and should be treated as estimates only. Actual base vehicle, package and option pricing may vary from this estimate because of special local pricing, availability or pricing adjustments not reflected in the dealer's computer system. See salesperson for the most current information.



Standard Equipment & Specs (cont'd)

Type	Fixed		
Rear Head Restraints			
Control Number	Manual 3	Type	Adjustable
Front Seat Trim			
Material	Vinyl	Back material	Vinyl
Rear Seat Trim Group			
Material	Vinyl	Back material	Carpet
Convenience			
AC And Heat Type			
Air conditioning Underseat ducts	Manual Yes	Air filter	Yes
Audio System			
Radio Seek-scan	AM/FM stereo Yes	Radio grade	Regular
Audio Speakers			
Speaker type	Regular	Speakers	6
Audio Antenna			
Type	Fixed		
LCD Monitors			
1st row	1	Primary monitor size (inches)	2.3
Convenience Features			
12V DC power outlet	2		
Door Lock Activation			
Type	Manual		
Instrumentation Type			
Display	Analog		
Instrumentation Gauges			
Tachometer	Yes	Oil pressure	Yes
Engine temperature	Yes	Transmission fluid temp	Yes
Engine hour meter	Yes		
Instrumentation Warnings			
Oil pressure	Yes	Engine temperature	Yes
Battery	Yes	Lights on	Yes
Key	Yes	Low fuel	Yes
Door ajar	Yes	Service interval	Yes
Brake fluid	Yes		
Instrumentation Displays			
Clock	In-radio display	Exterior temp	Yes
Systems monitor	Yes		
Instrumentation Feature			
Trip computer	Yes	Trip odometer	Yes

Prices and content availability as shown are subject to change and should be treated as estimates only. Actual base vehicle, package and option pricing may vary from this estimate because of special local pricing, availability or pricing adjustments not reflected in the dealer's computer system. See salesperson for the most current information.



Standard Equipment & Specs (cont'd)

Steering Wheel Type			
Material	Urethane	Tilting	Manual
Telescoping	Manual		
Front Side Windows			
Window 1st row activation	Manual		
Windows Rear Side			
2nd row activation	Manual		
Window Features			
Tinted	Light		
Front Windshield			
Wiper	Variable intermittent		
Rear Windshield			
Window	Fixed		
Interior			
Passenger Visor			
Mirror	Yes		
Rear View Mirror			
Day-night	Yes		
Headliner			
Coverage	Full	Material	Cloth
Floor Trim			
Coverage	Full	Covering	Vinyl/rubber
Trim Feature			
Gear shift knob	Urethane	Interior accents	Chrome
Lighting			
Dome light type	Fade	Front reading	Yes
Rear reading	Yes	Variable IP lighting	Yes
Overhead Console Storage			
Storage	Yes	Type	Full
Storage			
Front Beverage holder(s)	Yes	Glove box	Locking
Illuminated	Yes	Instrument panel	Bin
Dashboard	Covered		
Legroom			
Front	43.9"	Rear	43.6"
Headroom			
Front	40.8"	Rear	40.4"
Hip Room			
Front	62.5"	Rear	64.7"
Shoulder Room			

Prices and content availability as shown are subject to change and should be treated as estimates only. Actual base vehicle, package and option pricing may vary from this estimate because of special local pricing, availability or pricing adjustments not reflected in the dealer's computer system. See salesperson for the most current information.

Prepared for: STATE OF WV
 By: CHARLES ELLIS Date: 09/25/2017



Thornhill Ford Lincoln
U.S. Route 119 North, Chapmanville, West Virginia,
25508
Office: 304-855-8300

2017 F-550 Chassis, SD Crew Cab
4x4 SD Crew Cab 203" WB DRW XL(W5H)
Price Level: 755 Quote ID: DOHCrew550

Standard Equipment & Specs (cont'd)

Front	66.7"	Rear	65.9"
<i>Interior Volume</i>			
Passenger volume	131.7 cu.ft.		

Prices and content availability as shown are subject to change and should be treated as estimates only. Actual base vehicle, package and option pricing may vary from this estimate because of special local pricing, availability or pricing adjustments not reflected in the dealer's computer system. See salesperson for the most current information.

Prepared for: STATE OF WV
By: CHARLES ELLIS Date: 09/25/2017



Thornhill Ford Lincoln
U.S. Route 119 North, Chapmanville, West Virginia,
25508
Office: 304-855-8300

2017 F-550 Chassis, SD Crew Cab
4x4 SD Crew Cab 203" WB DRW XL(W5H)
Price Level: 755 Quote ID: DOHCrew550

Warranty - Standard Equipment & Specs

Warranty

Basic

Distance	36000 miles	Months	36 months
----------	-------------	--------	-----------

Powertrain

Distance	60000 miles	Months	60 months
----------	-------------	--------	-----------

Corrosion Perforation

Distance	Unlimited miles	Months	60 months
----------	-----------------	--------	-----------

Roadside Assistance

Distance	60000 miles	Months	60 months
----------	-------------	--------	-----------

Prices and content availability as shown are subject to change and should be treated as estimates only. Actual base vehicle, package and option pricing may vary from this estimate because of special local pricing, availability or pricing adjustments not reflected in the dealer's computer system. See salesperson for the most current information.

Prepared for: STATE OF WV
By: CHARLES ELLIS Date: 09/25/2017



Performance

Performance predictions in this report represent an estimate of vehicle performance based on standard operating conditions. Variations in customer equipment, load configuration, ambient conditions, and/or operator driving techniques can cause significant variations in vehicle performance. These values are not representative of results that may be shown in actual dynamometer tests. This report should therefore be used as a guide for comparative vehicle performance.

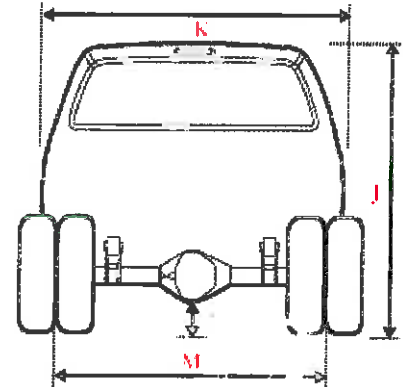
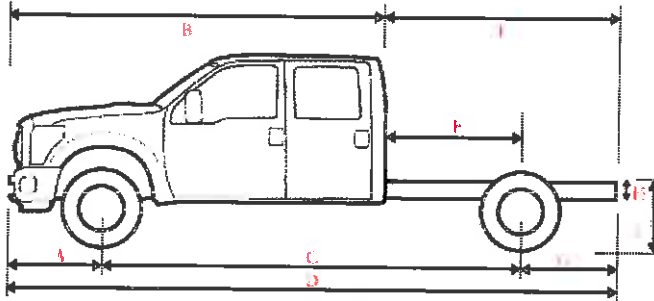

Dimensions

A	Front of Bumper to Front Axle	38.30 in.
B	Front Bumper to Back of Cab (BBC)	158.10 in.
C	Wheelbase (WB)	203.00 in.
D	Overall Length (OAL)	289.20 in.
E	Back of Cab to Rear Axle (CA)	84.00 in.
F	Back of Cab to End of Frame	131.20 in.
G	Rear Axle to End of Frame (AF)	47.20 in.
H	Frame Section Height	N/A
I	Rear Frame Height Unloaded	34.30 in.
I	Rear Frame Height Loaded	28.60 in.
J	Cab Height	81.70 in.
K	Body Width	80.00 in.
L	Maximum Ground Clearance	N/A
L	Minimum Ground Clearance	8.20 in.
M	Front Tread	74.80 in.
M	Rear Tread	74.00 in.

Prices and content availability as shown are subject to change and should be treated as estimates only. Actual base vehicle, package and option pricing may vary from this estimate because of special local pricing, availability or pricing adjustments not reflected in the dealer's computer system. See salesperson for the most current information.

Prepared for: STATE OF WV
 By: CHARLES ELLIS Date: 09/25/2017



Performance (cont'd)

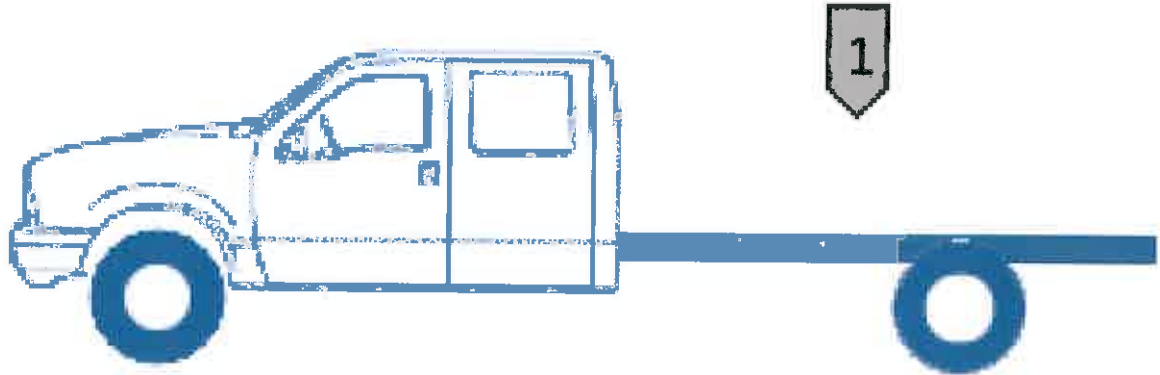

Weight

GVW	Front Axle	Rear Axle	Totals
Chassis	5,099 lbs	3,563 lbs	8,662 lbs
Body	0 lbs	0 lbs	0 lbs
Occupants Weight	600 lbs	300 lbs	900 lbs
1 Max Payload - (Max Payload)	1,301 lbs	8,637 lbs	9,938 lbs
TOTAL	7,000 lbs	12,500 lbs	19,500 lbs

Ratings	Front Axle	Rear Axle	GVWR
GAWR	7,000 lbs	14,706 lbs	19,500 lbs
Wheels/Tires	7,500 lbs	15,000 lbs	
Suspension	7,000 lbs	15,000 lbs	
Axle	7,000 lbs	14,706 lbs	
Legal Axle Limit	0 lbs	0 lbs	

Prices and content availability as shown are subject to change and should be treated as estimates only. Actual base vehicle, package and option pricing may vary from this estimate because of special local pricing, availability or pricing adjustments not reflected in the dealer's computer system. See salesperson for the most current information.

Prepared for: STATE OF WV
 By: CHARLES ELLIS Date: 09/25/2017



Performance (cont'd)

Start, Grade and Speed

Start	Ratio	Desired	Calculated
Start grade capability in 1st gear	3.97	15.00 %	42.71 %
Start grade capability in reverse	3.13	15.00 %	33.62 %
Grade	Ratio	Desired	Calculated
Maximum grade in 4th gear	1.15	3.00 %	13.00 %
Maximum grade in 5th gear	0.86	3.00 %	9.71 %
Maximum grade in 6th gear	0.67	3.00 %	7.63 %
Speed		Desired	Calculated
Top Speed (level grade)		75 mph	88 mph
<i>To meet your requirement you need a maximum axle ratio of 5.74</i>			
Top Speed on 3.0% grade		55 mph	
<i>To meet your requirement you need a maximum of 122 hp</i>			
Cruise Speed		60 mph	65 mph
Engine RPM at desired cruise speed			2,121 rpm

Variables in Use

Rear axle ratio:	4.88/4.88	Governed RPM:	3,120 rpm
Tire size:	225/70R19.5 (645 rev/mile)	Frontal Area:	40.39 Sq.Ft.
Gross Vehicle Weight (GVW):	19,500 lbs	Cruising RPM	2,300 rpm
Clutch engagement torque:	375 ft.lbs.	Worst road surface	Typical Highway
Torque conversion ratio:	1.90	Final Drive Ratio:	0.67
Peak engine torque:	750 ft.lbs.	Drag Coefficient	0.80
Engine Power:	330 hp @ 2,600 rpm		

Prices and content availability as shown are subject to change and should be treated as estimates only. Actual base vehicle, package and option pricing may vary from this estimate because of special local pricing, availability or pricing adjustments not reflected in the dealer's computer system. See salesperson for the most current information.



Performance (cont'd)

Shift Chart

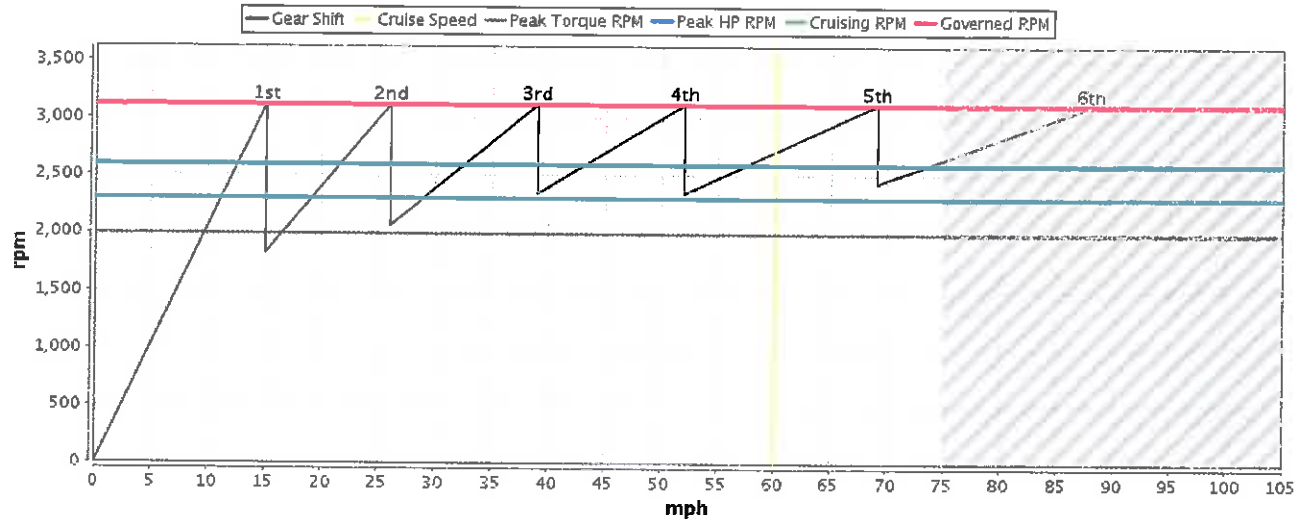

Turning Radius

Turning Radius

28.60 ft

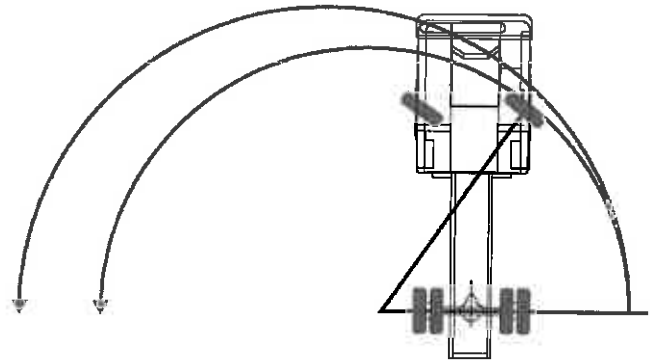

Prices and content availability as shown are subject to change and should be treated as estimates only. Actual base vehicle, package and option pricing may vary from this estimate because of special local pricing, availability or pricing adjustments not reflected in the dealer's computer system. See salesperson for the most current information.

Prepared for: STATE OF WV
 By: CHARLES ELLIS Date: 09/25/2017