



The following documentation is an electronically-submitted vendor response to an advertised solicitation from the *West Virginia Purchasing Bulletin* within the Vendor Self-Service portal at ***wvOASIS.gov***. As part of the State of West Virginia's procurement process, and to maintain the transparency of the bid-opening process, this documentation submitted online is publicly posted by the West Virginia Purchasing Division at ***WVPurchasing.gov*** with any other vendor responses to this solicitation submitted to the Purchasing Division in hard copy format.

## Header @ 8

[List View](#)

## General Information

[Contact](#)[Default Values](#)[Discount](#)[Document Information](#)

Procurement Folder: 314302

Procurement Type: Central Master Agreement

Vendor ID: 000000121592

Legal Name: GVM INC

Alias/DBA:

Total Bid: \$0.00

Response Date: 07/17/2017

Response Time: 10:12

SO Doc Code: CRFQ

SO Dept: 0803

SO Doc ID: DOT1700000097

Published Date: 7/10/17

Close Date: 7/18/17

Close Time: 13:30

Status: Closed

Solicitation Description: ADDENDUM\_1:  
POLYETHYLENE BRINE

Total of Header Attachments: 8

Total of All Attachments: 8



Line	Comm Ln Desc	Qty	Unit Issue	Unit Price	Ln Total Or Contract Amount
1	Vendor shall use Exhibit_A Pricing Page(s) for bid pricing.	0.00000	EA	\$0.000000	\$0.00

Comm Code	Manufacturer	Specification	Model #
25102001			

<b>Extended Description :</b>	<p>POLYETHYLENE BRINE STORAGE TANKS - PER EXHIBIT A PRICING PAGE</p> <p>Note: Vendor shall use Exhibit_A Pricing Page(s) for bid pricing. If vendor is submitting a bid online, Vendor should enter \$0.00 in the Oasis commodity line.</p>
-------------------------------	---

**Comments:** on 3.1.1.3,3.1.1.4,3.1.1.5, 3.1.1.6, bidding Snyder Captor Tanks

Vendor shall complete the Pricing Page by providing a Unit Cost per each Contract Item. Vendor shall complete the Pricing Page in its entirety as failure to do so may result in the Vendor's bid being disqualified. **Vendors must provide pricing for each item.** Pricing shall be considered for delivery, F.O.B., to any location within the state of West Virginia.

Vendor SHALL provide the brand name and model number for each contract item in the space provided after each Contract Item. Failure to provide the brand name and model number for each contract item may result in the Vendor's bid being disqualified.

Contract Item #	Estimated Quantity*	Description	Unit of Measure	Unit Cost	Extended Cost
3.1.1.1	1	2500 Gallon Heavy Weight Primary Tank with Connections	each	#####	\$ 2,100.00
		Brand Name, Primary: Norwesco			
		Model #, Primary: 40052			
3.1.1.2	1	6100 Gallon Heavy Weight Primary Tank with Connections	each	#####	\$ 4,550.00
		Brand Name, Primary: Norwesco			
		Model #, Primary: 40661			
3.1.1.3	1	2500 Gallon Heavy Weight Primary Tank with 6100 Gallon Premium Weight Secondary Containment Tank and Connections	each	#####	\$ 7,950.00
		Brand Name, Primary: Snyder			
		Model #, Primary: 5580000N45			
		Brand Name, Secondary: Snyder			
3.1.1.4	1	6100 Gallon Heavy Weight Primary Tank with 10,000 Gallon Premium Weight Secondary Containment Tank and Connections	each	#####	\$ 20,770.00
		Brand Name, Primary: Snyder			
		Model #, Primary: 56740000N75			
		Brand Name, Secondary: Snyder			
3.1.1.5	1	2500 Gallon Heavy Weight Primary Tank with 6100 Gallon Heavy Weight Secondary Containment Tank and Connections	each	#####	\$ 7,950.00
		Brand Name, Primary: Sntder			
		Model #, Primary: 5580000N45			
		Brand Name, Secondary: Snyder			
3.1.1.6	1	6100 Gallon Heavy Weight Primary Tank with 10,000 Gallon Heavy Weight Secondary Containment Tank and Connections	each	#####	\$ 20,770.00
		Brand Name, Primary: Snyder			
		Model #, Primary: 56740000N45			
		Brand Name, Secondary: Snyder			
		<b>TOTAL OVERALL COST</b>			\$ 64,090.00

\* The Pricing Page contains a list of Contract Items with no guarantee that any Contract Item will be purchased throughout the life of this Contract.

**ADDENDUM ACKNOWLEDGEMENT FORM**  
**SOLICITATION NO.: CRFO 0803 DOT170000097**

**Instructions:** Please acknowledge receipt of all addenda issued with this solicitation by completing this addendum acknowledgment form. Check the box next to each addendum received and sign below. Failure to acknowledge addenda may result in bid disqualification.

**Acknowledgment:** I hereby acknowledge receipt of the following addenda and have made the necessary revisions to my proposal, plans and/or specification, etc.

**Addendum Numbers Received:**

(Check the box next to each addendum received)

- |  |  |
|--|--|
| <input checked="" type="checkbox"/> Addendum No. 1 | <input type="checkbox"/> Addendum No. 6  |
| <input type="checkbox"/> Addendum No. 2            | <input type="checkbox"/> Addendum No. 7  |
| <input type="checkbox"/> Addendum No. 3            | <input type="checkbox"/> Addendum No. 8  |
| <input type="checkbox"/> Addendum No. 4            | <input type="checkbox"/> Addendum No. 9  |
| <input type="checkbox"/> Addendum No. 5            | <input type="checkbox"/> Addendum No. 10 |

I understand that failure to confirm the receipt of addenda may be cause for rejection of this bid. I further understand that that any verbal representation made or assumed to be made during any oral discussion held between Vendor's representatives and any state personnel is not binding. Only the information issued in writing and added to the specifications by an official addendum is binding.

GVM, Inc.  
Company  
Thomas Rain  
Authorized Signature  
7/14/2017  
Date

NOTE: This addendum acknowledgment should be submitted with the bid to expedite document processing.

**DESIGNATED CONTACT:** Vendor appoints the individual identified in this Section as the Contract Administrator and the initial point of contact for matters relating to this Contract.

Thomas Bair Vice President  
(Name, Title)  
Thomas Bair Vice President  
(Printed Name and Title)  
224 East King St. East Berlin, PA, 17316  
(Address)  
717-259-1577 / 717-259-1588  
(Phone Number) / (Fax Number)  
TLB@GVMINC.COM  
(email address)

**CERTIFICATION AND SIGNATURE:** By signing below, or submitting documentation through wvOASIS, I certify that I have reviewed this Solicitation in its entirety; that I understand the requirements, terms and conditions, and other information contained herein; that this bid, offer or proposal constitutes an offer to the State that cannot be unilaterally withdrawn; that the product or service proposed meets the mandatory requirements contained in the Solicitation for that product or service, unless otherwise stated herein; that the Vendor accepts the terms and conditions contained in the Solicitation, unless otherwise stated herein; that I am submitting this bid, offer or proposal for review and consideration; that I am authorized by the vendor to execute and submit this bid, offer, or proposal, or any documents related thereto on vendor's behalf; that I am authorized to bind the vendor in a contractual relationship; and that to the best of my knowledge, the vendor has properly registered with any State agency that may require registration.

GVM, Inc.  
(Company)  
Thomas Bair Vice President  
(Authorized Signature) (Representative Name, Title)  
Thomas Bair Vice President  
(Printed Name and Title of Authorized Representative)  
7/14/2017  
(Date)  
717-259-1577 // 717-259-1588  
(Phone Number) (Fax Number)

STATE OF WEST VIRGINIA  
Purchasing Division

# PURCHASING AFFIDAVIT

**MANDATE:** Under W. Va. Code §5A-3-10a, no contract or renewal of any contract may be awarded by the state or any of its political subdivisions to any vendor or prospective vendor when the vendor or prospective vendor or a related party to the vendor or prospective vendor is a debtor and: (1) the debt owed is an amount greater than one thousand dollars in the aggregate; or (2) the debtor is in employer default.

**EXCEPTION:** The prohibition listed above does not apply where a vendor has contested any tax administered pursuant to chapter eleven of the W. Va. Code, workers' compensation premium, permit fee or environmental fee or assessment and the matter has not become final or where the vendor has entered into a payment plan or agreement and the vendor is not in default of any of the provisions of such plan or agreement.

**DEFINITIONS:**

**"Debt"** means any assessment, premium, penalty, fine, tax or other amount of money owed to the state or any of its political subdivisions because of a judgment, fine, permit violation, license assessment, defaulted workers' compensation premium, penalty or other assessment presently delinquent or due and required to be paid to the state or any of its political subdivisions, including any interest or additional penalties accrued thereon.

**"Employer default"** means having an outstanding balance or liability to the old fund or to the uninsured employers' fund or being in policy default, as defined in W. Va. Code § 23-2c-2, failure to maintain mandatory workers' compensation coverage, or failure to fully meet its obligations as a workers' compensation self-insured employer. An employer is not in employer default if it has entered into a repayment agreement with the Insurance Commissioner and remains in compliance with the obligations under the repayment agreement.

**"Related party"** means a party, whether an individual, corporation, partnership, association, limited liability company or any other form or business association or other entity whatsoever, related to any vendor by blood, marriage, ownership or contract through which the party has a relationship of ownership or other interest with the vendor so that the party will actually or by effect receive or control a portion of the benefit, profit or other consideration from performance of a vendor contract with the party receiving an amount that meets or exceeds five percent of the total contract amount.

**AFFIRMATION:** By signing this form, the vendor's authorized signer affirms and acknowledges under penalty of law for false swearing (W. Va. Code §61-5-3) that neither vendor nor any related party owe a debt as defined above and that neither vendor nor any related party are in employer default as defined above, unless the debt or employer default is permitted under the exception above.

**WITNESS THE FOLLOWING SIGNATURE:**

Vendor's Name: GVM, Inc.

Authorized Signature: Thomas Ban Date: 7/14/2017

State of Pennsylvania

County of Adams, to-wit:

Taken, subscribed, and sworn to before me this 14<sup>th</sup> day of July, 2017.

My Commission expires 10-11, 2020

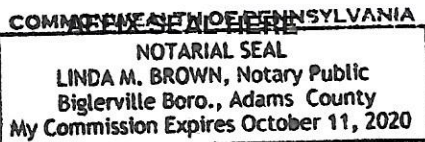

NOTARY PUBLIC Linda M. Brown



State of West Virginia  
**VENDOR PREFERENCE CERTIFICATE**

Certification and application is hereby made for Preference in accordance with **West Virginia Code**, §5A-3-37. (Does not apply to construction contracts). **West Virginia Code**, §5A-3-37, provides an opportunity for qualifying vendors to request (at the time of bid) preference for their residency status. Such preference is an evaluation method only and will be applied only to the cost bid in accordance with the **West Virginia Code**. This certificate for application is to be used to request such preference. The Purchasing Division will make the determination of the Vendor Preference, if applicable.

1.  **Application is made for 2.5% vendor preference for the reason checked:**  
 Bidder is an individual resident vendor and has resided continuously in West Virginia for four (4) years immediately preceding the date of this certification; **or**,  
 Bidder is a partnership, association or corporation resident vendor and has maintained its headquarters or principal place of business continuously in West Virginia for four (4) years immediately preceding the date of this certification;  
 Bidder is a resident vendor partnership, association, or corporation with at least eighty percent of ownership interest of bidder held by another entity that meets the applicable four year residency requirement; **or**,  
 Bidder is a nonresident vendor which has an affiliate or subsidiary which employs a minimum of one hundred state residents and which has maintained its headquarters or principal place of business within West Virginia continuously for the four (4) years immediately preceding the date of this certification; **or**,
2.  **Application is made for 2.5% vendor preference for the reason checked:**  
 Bidder is a resident vendor who certifies that, during the life of the contract, on average at least 75% of the employees working on the project being bid are residents of West Virginia who have resided in the state continuously for the two years immediately preceding submission of this bid; **or**,
3.  **Application is made for 2.5% vendor preference for the reason checked:**  
 Bidder is a nonresident vendor that employs a minimum of one hundred state residents, or a nonresident vendor which has an affiliate or subsidiary which maintains its headquarters or principal place of business within West Virginia and employs a minimum of one hundred state residents, and for purposes of producing or distributing the commodities or completing the project which is the subject of the bidder's bid and continuously over the entire term of the project, on average at least seventy-five percent of the bidder's employees or the bidder's affiliate's or subsidiary's employees are residents of West Virginia who have resided in the state continuously for the two immediately preceding years and the vendor's bid; **or**,
4.  **Application is made for 5% vendor preference for the reason checked:**  
 Bidder meets either the requirement of both subdivisions (1) and (2) or subdivision (1) and (3) as stated above; **or**,
5.  **Application is made for 3.5% vendor preference who is a veteran for the reason checked:**  
 Bidder is an individual resident vendor who is a veteran of the United States armed forces, the reserves or the National Guard and has resided in West Virginia continuously for the four years immediately preceding the date on which the bid is submitted; **or**,
6.  **Application is made for 3.5% vendor preference who is a veteran for the reason checked:**  
 Bidder is a resident vendor who is a veteran of the United States armed forces, the reserves or the National Guard, if, for purposes of producing or distributing the commodities or completing the project which is the subject of the vendor's bid and continuously over the entire term of the project, on average at least seventy-five percent of the vendor's employees are residents of West Virginia who have resided in the state continuously for the two immediately preceding years.
7.  **Application is made for preference as a non-resident small, women- and minority-owned business, in accordance with West Virginia Code §5A-3-59 and West Virginia Code of State Rules.**  
 Bidder has been or expects to be approved prior to contract award by the Purchasing Division as a certified small, women- and minority-owned business.

Bidder understands if the Secretary of Revenue determines that a Bidder receiving preference has failed to continue to meet the requirements for such preference, the Secretary may order the Director of Purchasing to: (a) rescind the contract or purchase order; or (b) assess a penalty against such Bidder in an amount not to exceed 5% of the bid amount and that such penalty will be paid to the contracting agency or deducted from any unpaid balance on the contract or purchase order.

By submission of this certificate, Bidder agrees to disclose any reasonably requested information to the Purchasing Division and authorizes the Department of Revenue to disclose to the Director of Purchasing appropriate information verifying that Bidder has paid the required business taxes, provided that such information does not contain the amounts of taxes paid nor any other information deemed by the Tax Commissioner to be confidential.

**Bidder hereby certifies that this certificate is true and accurate in all respects; and that if a contract is issued to Bidder and if anything contained within this certificate changes during the term of the contract, Bidder will notify the Purchasing Division in writing immediately.**

Bidder: GVM, Inc  
Date: 7/14/2017

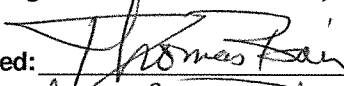
Signed:   
Title: Vice President

\*Check any combination of preference consideration(s) indicated above, which you are entitled to receive.

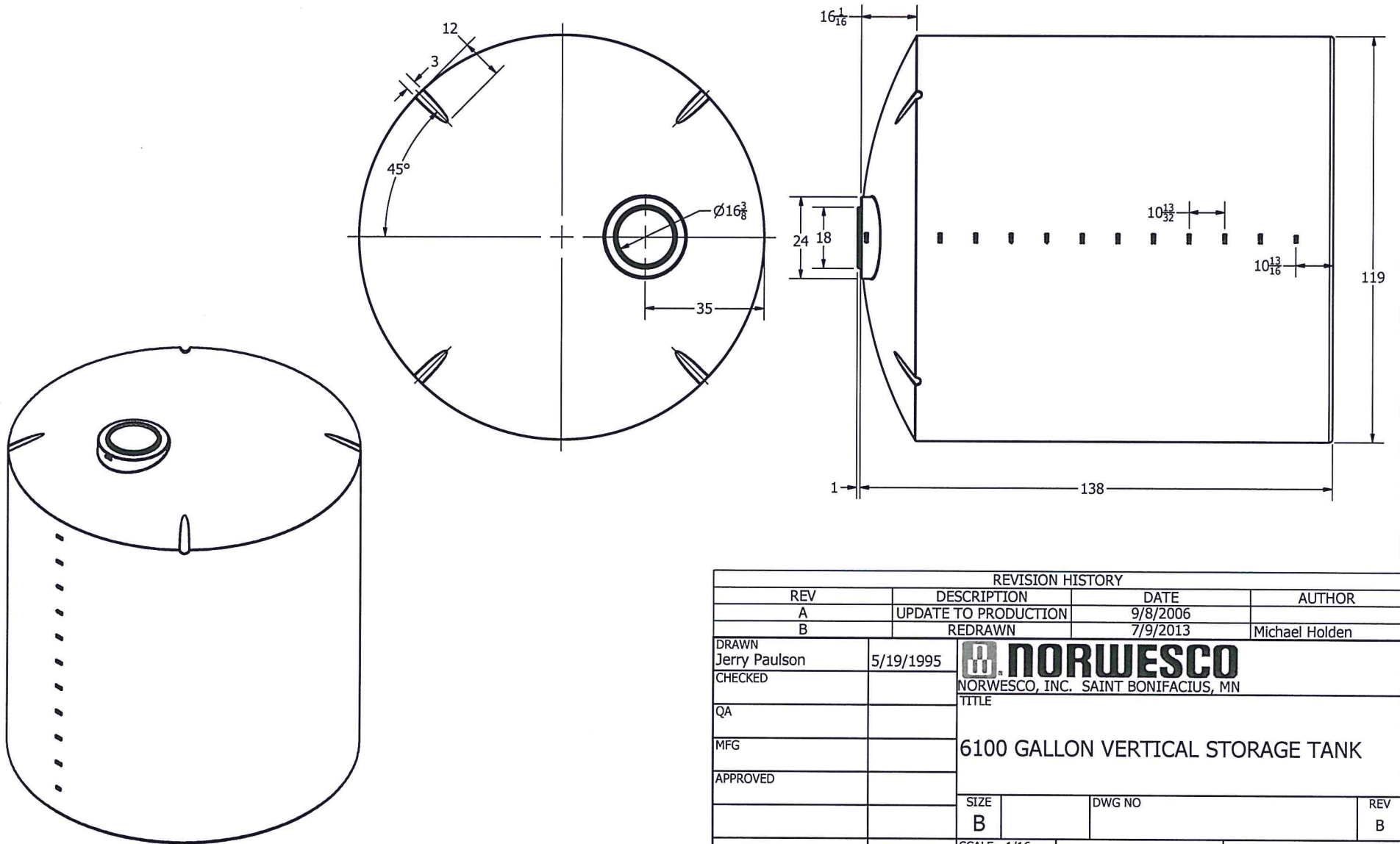

REVISION HISTORY			
REV	DESCRIPTION	DATE	AUTHOR
A	UPDATE TO PRODUCTION	9/8/2006	
B	REDRAWN	7/9/2013	Michael Holden

DRAWN Jerry Paulson	5/19/1995	 <b>NORWESCO</b> NORWESCO, INC. SAINT BONIFACIUS, MN TITLE 6100 GALLON VERTICAL STORAGE TANK	REV B
CHECKED			
QA			
MFG			
APPROVED			
		SIZE B	DWG NO
		SCALE: 1/16	SHEET 1 OF 1

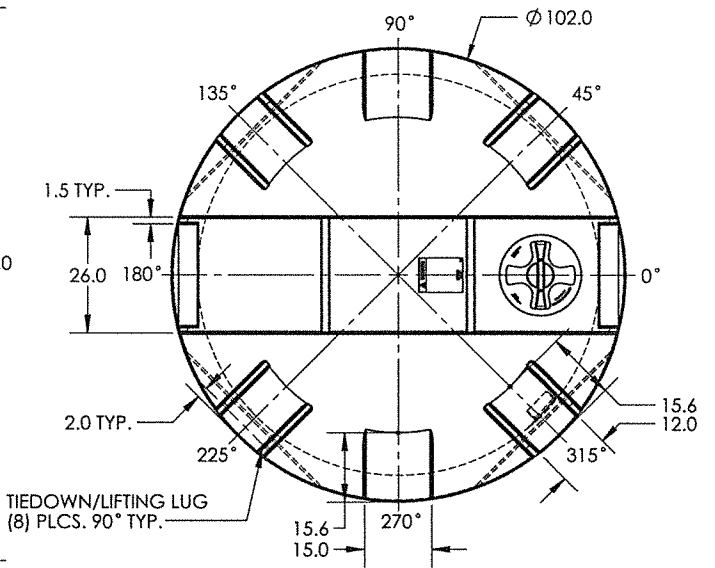
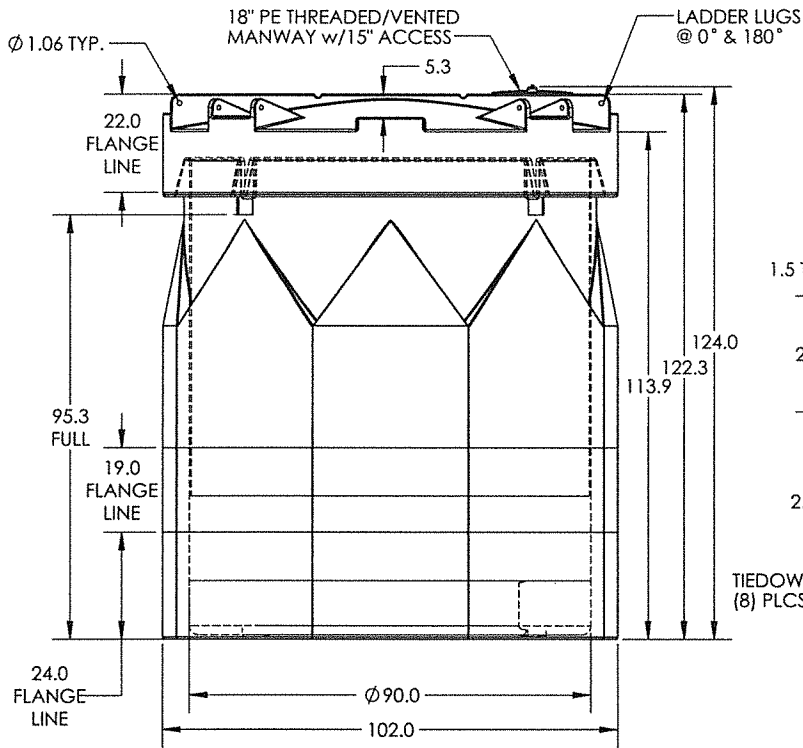

\*ALL EXTERNAL PIPING MUST BE INDEPENDENTLY SUPPORTED.  
 \*ONLY BASE FITTINGS TO BE LEFT INSTALLED AT TIME OF SHIPMENT PER SH PROCEDURE.  
 \*Consult Snyder's Guidelines for Use and Installation prior to delivery.  
 Available on-line at <http://www.snyderindustriestanks.com/Technical>  
 ALL DIMENSIONS ARE IN INCHES, NOMINAL, & SUBJECT TO CHANGE WITHOUT NOTICE.  
 ALL DIMENSIONS ON ROTATIONAL MOLDED PARTS ARE SUBJECT TO A ± 3% TOLERANCE.

DO NOT SCALE		DRAWN BY	TITLE		REVISION
STATUS:	Released	ET3	 <b>ASM TK 2500 CCS</b>		<b>A</b>
© SNYDER INDUSTRIES INC., 2015			PART NO.		SHEET
<small>ALL DIMENSIONS, DESIGN, AND INFORMATION ON THIS PRINT MUST BE CONSIDERED PROPRIETARY TO SNYDER INDUSTRIES, INC. AND MAY NOT BE USED, COPIED, OR DISTRIBUTED WITHOUT WRITTEN PERMISSION OF AN OFFICER (OR HIS AGENT) OF THE FIRM.</small>			<b>5580000N &amp; 5510000N</b>		1 OF 1
			(402) 467-5221 <a href="http://www.snyderinet.com">www.snyderinet.com</a>		ENG. ID. <b>A003552</b>

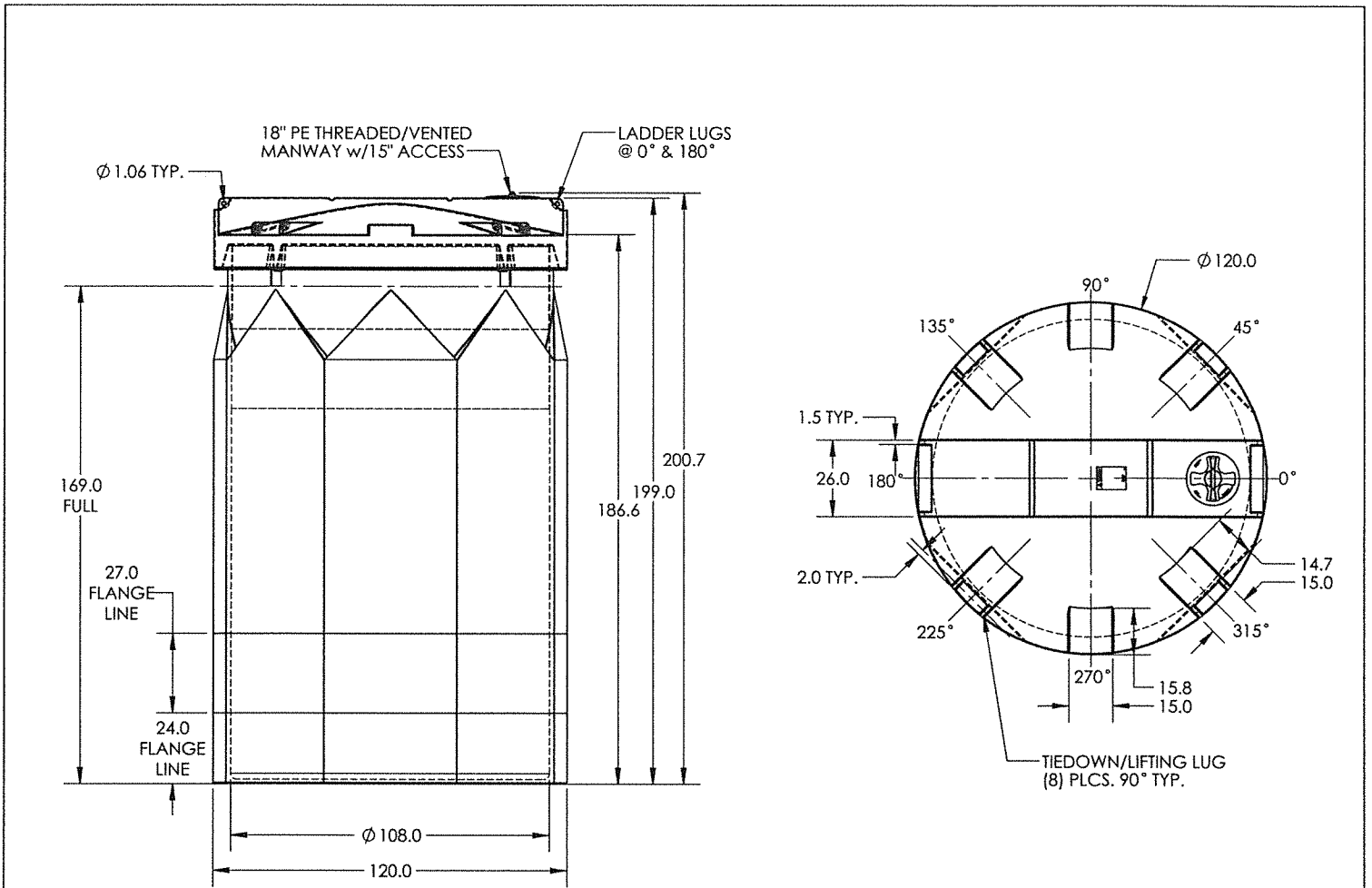

\*ALL EXTERNAL PIPING MUST BE INDEPENDENTLY SUPPORTED.  
 \*ONLY BASE FITTINGS TO BE LEFT INSTALLED AT TIME OF SHIPMENT PER SII PROCEDURE.  
 \*Consult Snyder's Guidelines for Use and Installation prior to delivery.  
 Available on-line at <http://www.snyderindustriestanks.com/Technical>  
 ALL DIMENSIONS ARE IN INCHES, NOMINAL, & SUBJECT TO CHANGE WITHOUT NOTICE.  
 ALL DIMENSIONS ON ROTATIONAL MOLDED PARTS ARE SUBJECT TO A ± 3% TOLERANCE.

DO NOT SCALE		DRAWN BY	TITLE		REVISION
STATUS: Released		ET3	 <b>ASM TK 6500CP X 108</b>		<b>A</b>
© SNYDER INDUSTRIES INC., 2016			FART NO. <b>5670000N &amp; 5650000N</b>		SHEET 1 OF 1
<small>ALL DIMENSIONS, DESIGN, AND INFORMATION ON THIS PRINT MUST BE CONSIDERED PROPRIETARY TO SNYDER INDUSTRIES, INC. AND MAY NOT BE USED, COPIED, OR DISTRIBUTED WITHOUT WRITTEN PERMISSION OF AN OFFICER (OR HIS AGENT) OF THE FIRM.</small>			<small>(402) 467-5221</small> <small>www.snyderintl.com</small>		ENG. ID. <b>A003591</b>



1.888.422.8683 [sales@snydernet.com](mailto:sales@snydernet.com)

[HOME](#) [PRODUCTS](#) [INDUSTRIES SERVED](#) [TECHNICAL](#) [FAQS](#)

[CONTACT US](#) [RESOURCES](#) [CORPORATE](#) [DISTRIBUTOR LOG IN](#)

[FACTORY OUTLET](#) [SHOP DIRECT](#)

## Double Wall Tanks

### Captor Double Wall Containment





Snyder's revolutionary Captor Containment System is designed to alleviate the ever-changing environmental and safety concerns regarding bulk chemical storage and containment for the 21st century.

Captor's unique tank-in-a-tank design enables users and specifiers to incorporate advance performance and safety features on a bulk-handling system, which provides total containment protection. Captor's double wall construction is completely enclosed so that external matter, such as dust, rain and snow is prevented from collecting in the outer containment tank.

Besides delivering unparalleled performance benefits, Captor Containment Systems also contribute to your company's bottom line by significantly reducing installation and procurement cost. Every Captor is shipped fully-assembled on either a standard or wide load flat bed trailers, which reduces comparable costs by an average of 35 percent.

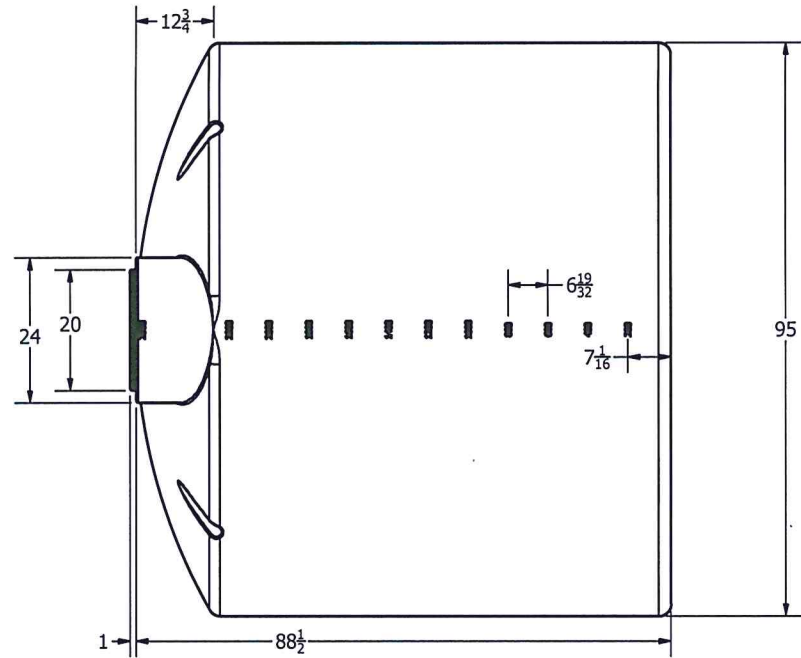
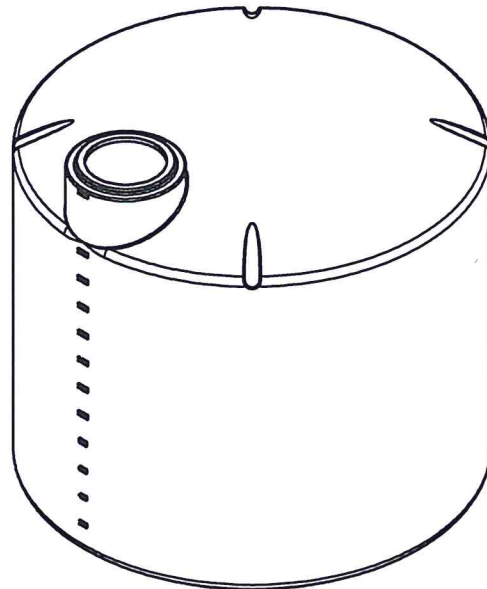
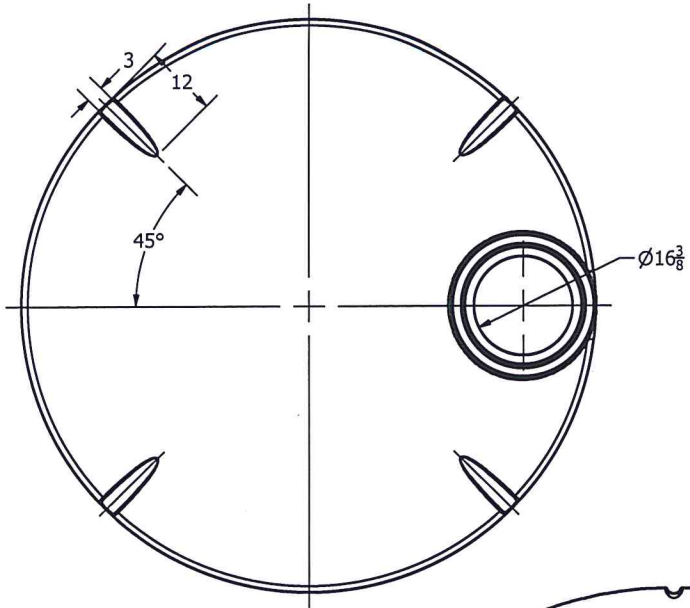
- Industrial (ASTM D1998) design standards.
- Material options for a diverse range of applications.
- High-density linear polyethylene (HDLPE)\* - black and natural white color complies with FDA Regulation 177.1520 and NSF/ANSI 61 standards.
- Cross-linked, high density polyethylene (XLPE) - black and natural white color.
- Opaque white sodium hypochlorite resin #880059.
- Sulfuric acid resin #880046.
- Available with IBC/CBC seismic and 150 mph wind restraint tie-down systems.
- Specific gravity ratings are based on the industry's most severe calculation.
- Standard specific gravity choices are 1.5 and 1.9, other ratings are available upon request.
- All materials are UV stabilized for long-term outdoor service.



REVISION HISTORY			
REV	DESCRIPTION	DATE	AUTHOR
C	REDRAWN	5/1/1996	
D	REDRAWN	7/16/2013	Michael Holden
DRAWN	Jerry Paulson	5/1/1996	 NORWESCO, INC. SAINT BONIFACIUS, MN TITLE 2500 GALLON VERTICAL STORAGE TANK
CHECKED			
QA			
MFG			
APPROVED			
	SIZE	DWG NO	REV
	B		D
SCALE: 1/16		SHEET 1 OF 1	