



The following documentation is an electronically-submitted vendor response to an advertised solicitation from the *West Virginia Purchasing Bulletin* within the Vendor Self-Service portal at ***wvOASIS.gov***. As part of the State of West Virginia's procurement process, and to maintain the transparency of the bid-opening process, this documentation submitted online is publicly posted by the West Virginia Purchasing Division at ***WVPurchasing.gov*** with any other vendor responses to this solicitation submitted to the Purchasing Division in hard copy format.

## Header @ 29

 List View

## General Information

Contact

Default Values

Discount

Document Information

Procurement Folder: 387807

SO Doc Code: CRFQ

Procurement Type: Central Purchase Order

SO Dept: 0608

Vendor ID:  

SO Doc ID: COR1800000008

Legal Name: ADVANTAGE EQUIPMENT INC

Published Date: 11/14/17

Alias/DBA:

Close Date: 11/21/17

Total Bid: \$25,346.00

Close Time: 13:30

Response Date:  

Status: Closed

Response Time: Solicitation Description:  

Total of Header Attachments: 29

Total of All Attachments: 29



Purchasing Division  
 2019 Washington Street East  
 Post Office Box 50130  
 Charleston, WV 25305-0130

**State of West Virginia  
 Solicitation Response**

**Proc Folder :** 387807

**Solicitation Description :** ADDENDUM 3 COMMERCIAL ELECTRIC CLOTHES DRYERS

**Proc Type :** Central Purchase Order

Date issued	Solicitation Closes	Solicitation Response	Version
	2017-11-21 13:30:00	SR 0608 ESR11101700000002084	1

**VENDOR**

000000177139

ADVANTAGE EQUIPMENT INC

**Solicitation Number:** CRFQ 0608 COR1800000008

**Total Bid :** \$25,346.00

**Response Date:** 2017-11-16

**Response Time:** 15:43:32

**Comments:** THE ATTACHED MANUAL IS FOR MULTIPLE MODELS OF THE DRYER. WE ARE MEETING THE SPEC WITH AN ELECTRIC DRYER 240/60/1, REVERSABLE DOOR, PAINTED PANELS.

**FOR INFORMATION CONTACT THE BUYER**

Crystal Rink  
 (304) 558-2402  
 crystal.g.rink@wv.gov

**Signature on File**

**FEIN #**

**DATE**

All offers subject to all terms and conditions contained in this solicitation

Line	Comm Ln Desc	Qty	Unit Issue	Unit Price	Ln Total Or Contract Amount
1	COMMERCIAL ELECTRIC CLOTHES DRYERS	29.00000	EA	\$874.000000	\$25,346.00

Comm Code	Manufacturer	Specification	Model #
47111503			

<b>Extended Description :</b>	COMMERCIAL ELECTRIC CLOTHES DRYERS
-------------------------------	------------------------------------

**Comments:** 1. Delivery 30 Business days ARO 2. 30 DAY LABOR WARRANTY INCLUDING SHIPPING ON WARRANTY PARTS



Purchasing Division  
 2019 Washington Street East  
 Post Office Box 50130  
 Charleston, WV 25305-0130

State of West Virginia  
 Request for Quotation  
 20 - Household Items

Proc Folder: 387807

Doc Description: ADDENDUM 3 COMMERCIAL ELECTRIC CLOTHES DRYERS

Proc Type: Central Purchase Order

Date Issued	Solicitation Closes	Solicitation No	Version
2017-11-14	2017-11-21 13:30:00	CRFQ 0608 COR1800000008	4

**BID RECEIVING LOCATION**

BID CLERK  
 DEPARTMENT OF ADMINISTRATION  
 PURCHASING DIVISION  
 2019 WASHINGTON ST E  
 CHARLESTON WV 25305  
 US

**VENDOR**

Vendor Name, Address and Telephone Number:

*ADVANTAGE EQUIPMENT INC  
 1056 HOME AVE  
 ARRON OHIO 44310*

**FOR INFORMATION CONTACT THE BUYER**

Crystal Rink  
 (304) 558-2402  
 crystal.g.rink@wv.gov

Signature X

*[Handwritten Signature]*

FEIN #

*34-1847794*

DATE

*11/17/17*

All offers subject to all terms and conditions contained in this solicitation

**ADDITIONAL INFORMATION:**

THE STATE OF WEST VIRGINIA PURCHASING DIVISION FOR THE AGENCY, WEST VIRGINIA DIVISION OF CORRECTIONS, IS SOLICITING BIDS TO ESTABLISH A CONTRACT FOR THE ONE-TIME PURCHASE OF ELECTRIC CLOTHES DRYERS FOR VARIOUS LOCATIONS PER THE ATTACHED.

INVOICE TO		SHIP TO	
FISCAL DEPARTMENT DIVISION OF CORRECTIONS - CENTRAL OFFICE 1409 GREENBRIER ST STE 300		FISCAL DEPARTMENT DIVISION OF CORRECTIONS - CENTRAL OFFICE STE 300 1409 GREENBRIER ST	
CHARLESTON	WV25311	CHARLESTON	WV 25311
US		US	

Line	Comm Ln Desc	Qty	Unit Issue	Unit Price	Total Price
1	COMMERCIAL ELECTRIC CLOTHES DRYERS	29.00000	EA		

Comm Code	Manufacturer	Specification	Model #
47111503			

Extended Description :  
COMMERCIAL ELECTRIC CLOTHES DRYERS

**SCHEDULE OF EVENTS**

Line	Event	Event Date
1	VENDOR QUESTION DEADLINE	2017-11-08

**SOLICITATION NUMBER: CRFQ COR1800000008**  
**Addendum Number: 1**

---

The purpose of this addendum is to modify the solicitation identified as ("Solicitation") to reflect the change(s) identified and described below.

**Applicable Addendum Category:**

- | Modify bid opening date and time
- | Modify specifications of product or service being sought
- | Attachment of vendor questions and responses
- | Attachment of pre-bid sign-in sheet
- | Correction of error
- | Other

**Description of Modification to Solicitation:**

1. To provide answers to vendor questions

No other changes at this time

Bid opening remains 11/16/2017 at 1:30 PM EST

**Additional Documentation:** Documentation related to this Addendum (if any) has been included herewith as Attachment A and is specifically incorporated herein by reference.

**Terms and Conditions:**

1. All provisions of the Solicitation and other addenda not modified herein shall remain in full force and effect.
2. Vendor should acknowledge receipt of all addenda issued for this Solicitation by completing an Addendum Acknowledgment, a copy of which is included herewith. Failure to acknowledge addenda may result in bid disqualification. The addendum acknowledgement should be submitted with the bid to expedite document processing.

# ATTACHMENT A



**CRFQ 0608 COR1800000008**

**Addendum 1**

**Answers to Vendor Questions**

**Q1:** Can you please provide us a copy of the bid tabulation or purchase order for the current equipment.

**A1:** Requesting copies of previously awarded contracts, other solicitations, or documents related to previous contracts through the question and answer process included in this solicitation is not appropriate. Requests for documentation of this nature can be obtained by interested parties through a Freedom of Information Act request.

**Clarification to Specifications:**

6 of the dryers need 4 prong power supplies, the remaining need 3 prong

**ADDENDUM ACKNOWLEDGEMENT FORM**  
**SOLICITATION NO.: COR1800000008**

**Instructions:** Please acknowledge receipt of all addenda issued with this solicitation by completing this addendum acknowledgment form. Check the box next to each addendum received and sign below. Failure to acknowledge addenda may result in bid disqualification.

**Acknowledgment:** I hereby acknowledge receipt of the following addenda and have made the necessary revisions to my proposal, plans and/or specification, etc.

**Addendum Numbers Received:**

(Check the box next to each addendum received)

- |  |  |
|--|--|
| <input checked="" type="checkbox"/> Addendum No. 1 | <input type="checkbox"/> Addendum No. 6  |
| <input checked="" type="checkbox"/> Addendum No. 2 | <input type="checkbox"/> Addendum No. 7  |
| <input checked="" type="checkbox"/> Addendum No. 3 | <input type="checkbox"/> Addendum No. 8  |
| <input type="checkbox"/> Addendum No. 4            | <input type="checkbox"/> Addendum No. 9  |
| <input type="checkbox"/> Addendum No. 5            | <input type="checkbox"/> Addendum No. 10 |

I understand that failure to confirm the receipt of addenda may be cause for rejection of this bid. I further understand that any verbal representation made or assumed to be made during any oral discussion held between Vendor's representatives and any state personnel is not binding. Only the information issued in writing and added to the specifications by an official addendum is binding.

ADVANTAGE Equipment INC  
Company  
[Signature]  
Authorized Signature  
11/17/17  
Date

**NOTE:** This addendum acknowledgement should be submitted with the bid to expedite document processing.

Revised 6/8/2012

**SOLICITATION NUMBER:** CRFQ COR1800000008  
**Addendum Number: 2**

---

The purpose of this addendum is to modify the solicitation identified as ("Solicitation") to reflect the change(s) identified and described below.

**Applicable Addendum Category:**

- | Modify bid opening date and time
- | Modify specifications of product or service being sought
- | Attachment of vendor questions and responses
- | Attachment of pre-bid sign-in sheet
- | Correction of error
- | Other

**Description of Modification to Solicitation:**

1. To modify specification 3.1.1.4
2. To extend the bid opening date to November 21, 2017 at 1:30 PM EST

**Additional Documentation:** Documentation related to this Addendum (if any) has been included herewith as Attachment A and is specifically incorporated herein by reference.

**Terms and Conditions:**

1. All provisions of the Solicitation and other addenda not modified herein shall remain in full force and effect.
2. Vendor should acknowledge receipt of all addenda issued for this Solicitation by completing an Addendum Acknowledgment, a copy of which is included herewith. Failure to acknowledge addenda may result in bid disqualification. The addendum acknowledgement should be submitted with the bid to expedite document processing.

**CRFQ 0608 COR1800000008**

**Addendum 2**

**Revised Specifications**

**Specification 3.1.1.4 has been modified to:**

- 3.1.1.4** Vendor must provide manufacturer's specifications, manufacturer's literature, and/or any other relevant verifiable documentation that demonstrates that the model provided meets the desired mandatory specifications. Vendor must submit documentation upon request.

**SOLICITATION NUMBER: CRFQ COR1800000008**

**Addendum Number: 3**

---

The purpose of this addendum is to modify the solicitation identified as ("Solicitation") to reflect the change(s) identified and described below.

**Applicable Addendum Category:**

- | Modify bid opening date and time
- | Modify specifications of product or service being sought
- | Attachment of vendor questions and responses
- | Attachment of pre-bid sign-in sheet
- | Correction of error
- | Other

**Description of Modification to Solicitation:**

1. To provide clarification on three and four prong dryers

No other changes at this time

Bid opening remain November 21, 2017 at 1:30 PM EST

**Additional Documentation:** Documentation related to this Addendum (if any) has been included herewith as Attachment A and is specifically incorporated herein by reference.

**Terms and Conditions:**

1. All provisions of the Solicitation and other addenda not modified herein shall remain in full force and effect.
2. Vendor should acknowledge receipt of all addenda issued for this Solicitation by completing an Addendum Acknowledgment, a copy of which is included herewith. Failure to acknowledge addenda may result in bid disqualification. The addendum acknowledgement should be submitted with the bid to expedite document processing.

CRFQ 0608 COR1800000008

Addendum 3

Clarifications

**Clarification regarding three prong and four prong dryers:**

Beckley Correctional Center will need 5 three prong dryers.

Charleston Correctional Center will need 6 four prong dryers.

Parkersburg Correctional Center will need 18 four prong dryers.

In total, 5 dryers will need to have 3 prong power chords and 24 dryers will need 4 prong power chords.

# Clothes Dryer

Nonmetered and Metered  
Electric and Gas Models

— Installation/Operation —

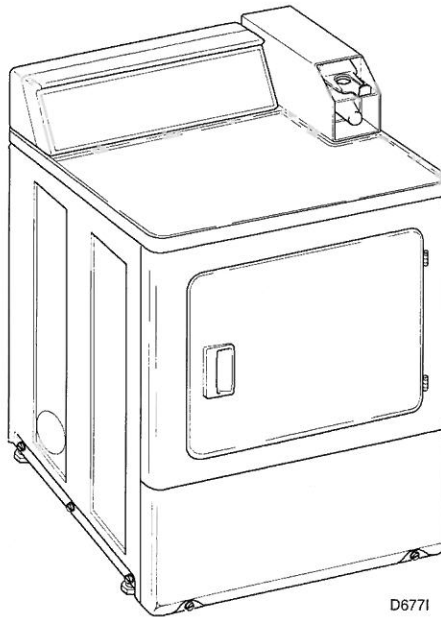

D6771

Para bajar una copia de estas instrucciones en español, visite [www.comlaundry.com](http://www.comlaundry.com).

**Keep These Instructions for Future Reference.**

(If this machine changes ownership, this manual must accompany machine.)



[www.comlaundry.com](http://www.comlaundry.com)

Part No. 512680R2  
July 2007



## WARNING

**FOR YOUR SAFETY**, the information in this manual must be followed to minimize the risk of fire or explosion or to prevent property damage, personal injury or death.

W033

- Do not store or use gasoline or other flammable vapors and liquids in the vicinity of this or any other appliance.
- **WHAT TO DO IF YOU SMELL GAS:**
  - Do not try to light any appliance.
  - Do not touch any electrical switch; do not use any phone in your building.
  - Clear the room, building or area of all occupants.
  - Immediately call your gas supplier from a neighbor's phone. Follow the gas supplier's instructions.
  - If you cannot reach your gas supplier, call the fire department.
- Installation and service must be performed by a qualified installer, service agency or the gas supplier.

W052

**IMPORTANT:** Purchaser must consult the local gas supplier for suggested instructions to be followed if the dryer user smells gas. The gas utility instructions plus the SAFETY and WARNING note directly above must be posted in a prominent location near the dryer for customer use.

## FOR YOUR SAFETY

**Do not store or use gasoline or other flammable vapors and liquids in the vicinity of this or any other appliance.**

W053

The following information applies to the state of Massachusetts, USA.

- This appliance can only be installed by a Massachusetts licensed plumber or gas fitter.
- This appliance must be installed with a 36 inch (91 cm) long flexible gas connector.
- A "T-Handle" type gas shut-off valve must be installed in the gas supply line to this appliance.
- This appliance must not be installed in a bedroom or bathroom.



# Table of Contents

<b>Safety Information</b> .....	4
Explanation of Safety Messages.....	4
Important Safety Instructions .....	4
<b>Installation</b> .....	6
Dimensions .....	6
Nonmetered Models.....	6
Metered Models .....	7
Before You Start.....	8
Tools .....	8
Card Reader Models .....	8
Installing the Dryer.....	9
Step 1: Position and Level the Dryer .....	9
Step 2: Connect Dryer Exhaust System .....	11
Exhaust Direction.....	12
Exhaust System.....	13
Multi-Dryer Installation Exhaust Requirements.....	14
Step 3: (Gas Dryer Only) Connect Gas Supply Pipe .....	16
Step 4: (Electric Dryer Only) Connect Electrical Plug.....	17
Step 5: Reverse Door, if Desired .....	23
Step 6: Wipe Out Inside of Dryer .....	24
Step 7: Plug In the Dryer .....	24
Step 8: Recheck Steps 1-7.....	26
Step 9: Check Heat Source .....	26
<b>Vending</b> .....	27
Meter Case .....	27
Coin Slide Control .....	27
Power-Up Mode.....	27
Ready Mode .....	27
Start Mode.....	27
Run Mode.....	27
Door Open Mode .....	27
End of Cycle Mode .....	27
Topoffs .....	27
Temperature Selector Switch.....	27
Error Display Mode .....	28
Setting Dry Time Dipswitches.....	28
Dipswitch Settings .....	29
Test Setting .....	31
Slide Extension .....	32
Additional Dryer Security.....	34

© Copyright 2007, Alliance Laundry Systems LLC

All rights reserved. No part of the contents of this book may be reproduced or transmitted in any form or by any means without the expressed written consent of the publisher.

<b>Operation</b> .....	35
Operation Instructions for Nonmetered and Coin Slide Dryers .....	35
Step 1: Clean Lint Filter.....	35
Step 2: Load Laundry.....	35
Step 3: Close Loading Door.....	35
Step 4: Set Fabric Selector.....	36
Step 5: Start Dryer .....	36
Operation Instructions for Electronic Display Control Dryers.....	37
Step 1: Clean Lint Filter.....	37
Step 2: Load Laundry.....	37
Step 3: Close Loading Door.....	37
Step 4: Set Fabric Selector.....	37
Step 5: Insert Coin(s) or Card .....	38
Step 6: Start Dryer .....	38
Indicator Lights .....	38
Operation Instructions for MDC Dryers.....	40
Step 1: Clean Lint Filter.....	40
Step 2: Load Laundry.....	40
Step 3: Close Loading Door.....	40
Step 4: Set Fabric Selector.....	41
Step 5: Insert Coin(s) or Card .....	41
Step 6: Start Dryer .....	41
Indicator Lights.....	41
Operation Instructions for NetMaster Dryers .....	42
Step 1: Clean Lint Filter.....	42
Step 2: Load Laundry.....	42
Step 3: Close Loading Door.....	42
Step 4: Set Fabric Selector.....	42
Step 5: Insert Coin(s) or Card .....	43
Step 6: Start Dryer .....	43
Indicator Lights.....	44
<b>Maintenance</b> .....	45
Lubrication.....	45
Care of Your Dryer .....	45
Dryer Interior .....	45
Cabinet .....	45
Control Panel .....	45
Exhaust System.....	45
Lint Filter .....	46
Motor Overload Protector.....	46
For Energy Conservation.....	46
<b>Troubleshooting</b> .....	47
<b>Contact Information</b> .....	48
<b>Installer Checklist</b> .....	Back Cover

# Safety Information

## Explanation of Safety Messages

Throughout this manual and on machine decals, you will find precautionary statements (“DANGER,” “WARNING,” and “CAUTION”) followed by specific instructions. These precautions are intended for the personal safety of the operator, user, servicer, and those maintaining the machine.

	<b>DANGER</b>
<b>Indicates an imminently hazardous situation that, if not avoided, will cause severe personal injury or death.</b>	

	<b>WARNING</b>
<b>Indicates a hazardous situation that, if not avoided, could cause severe personal injury or death.</b>	

	<b>CAUTION</b>
<b>Indicates a hazardous situation that, if not avoided, may cause minor or moderate personal injury or property damage.</b>	

Additional precautionary statements (“IMPORTANT” and “NOTE”) are followed by specific instructions.

**IMPORTANT:** The word “IMPORTANT” is used to inform the reader of specific procedures where minor machine damage will occur if the procedure is not followed.

**NOTE:** The word “NOTE” is used to communicate installation, operation, maintenance or servicing information that is important but not hazard related.

## Important Safety Instructions

### Save These Instructions

	<b>WARNING</b>
<b>To reduce the risk of fire, electric shock, or injury to persons when using your dryer, follow these basic precautions:</b>	
<small>W034</small>	

1. Read all instructions before using the dryer.
2. Refer to the GROUNDING INSTRUCTIONS in the INSTALLATION manual for the proper grounding of the dryer.
3. Do not dry articles that have been previously cleaned in, washed in, soaked in, or spotted with gasoline, dry-cleaning solvents, other flammable or explosive substances as they give off vapors that could ignite or explode.
4. Do not allow children to play on or in the dryer. Close supervision of children is necessary when the dryer is used near children. This is a safety rule for all appliances.
5. Before the dryer is removed from service or discarded, remove the door to the drying compartment.
6. Do not reach into the dryer if the cylinder is revolving.
7. Do not install or store the dryer where it will be exposed to water and/or weather.
8. Do not tamper with the controls.
9. Do not repair or replace any part of the dryer, or attempt any servicing unless specifically recommended in the user-maintenance instructions or in published user-repair instructions that you understand and have the skills to carry out.
10. Do not use fabric softeners or products to eliminate static unless recommended by the manufacturer of the fabric softener or product.
11. To reduce the risk of fire, DO NOT DRY plastics or articles containing foam rubber or similarly textured rubberlike materials.
12. ALWAYS clean the lint filter after every load. A layer of lint in the filter reduces drying efficiency and prolongs drying time.

13. Keep area around the exhaust opening and adjacent surrounding area free from the accumulation of lint, dust and dirt.
14. The interior of the dryer and the exhaust duct should be cleaned periodically by qualified service personnel.
15. If not installed, operated and maintained in accordance with the manufacturer's instructions or if there is damage to or mishandling of this product's components, use of this product could expose you to substances in the fuel or from fuel combustion which can cause death or serious illness and which are known to the State of California to cause cancer, birth defects or other reproductive harm.
16. Dryer will not operate with the loading door open. DO NOT bypass the door safety switch by permitting the dryer to operate with the door open. The dryer will stop tumbling when the door is opened. Do not use the dryer if it does not stop tumbling when the door is opened or starts tumbling without pressing the START mechanism. Remove the dryer from use and call the service person.
17. Do not put articles soiled with vegetable or cooking oil in the dryer, as these oils may not be removed during washing. Due to the remaining oil, the fabric may catch on fire by itself.
18. To reduce the risk of fire, DO NOT put clothes which have traces of any flammable substances such as machine oil, flammable chemicals, thinner, etc., or anything containing wax or chemicals such as in mops and cleaning cloths, or anything dry-cleaned at home with a dry-cleaning solvent in the dryer.
19. Use the dryer only for its intended purpose, drying clothes.
20. Always disconnect the electrical power to the dryer before attempting service. Disconnect the power cord by grasping the plug, not the cord.
21. If supply cord is damaged, it must be replaced by a special cord or assembly available from the manufacturer or its service agent.
22. Install this dryer according to the INSTALLATION INSTRUCTIONS. All connections for electrical power, grounding and gas supply must comply with local codes and be made by licensed personnel when required. Do not do it yourself unless you know how!
23. Remove laundry immediately after the dryer stops.
24. Always read and follow manufacturer's instructions on packages of laundry and cleaning aids. Heed all warnings or precautions. To reduce the risk of poisoning or chemical burns, keep them out of reach of children at all times (preferably in a locked cabinet).
25. Do not tumble fiberglass curtains and draperies unless the label says it can be done. If they are dried, wipe out the cylinder with a damp cloth to remove particles of fiberglass.
26. ALWAYS follow the fabric care instructions supplied by the garment manufacturer.
27. Never operate the dryer with any guards and/or panels removed.
28. DO NOT operate the dryer with missing or broken parts.
29. DO NOT bypass any safety devices.
30. Failure to install, maintain, and/or operate this machine according to the manufacturer's instructions may result in conditions which can produce bodily injury and/or property damage.

**IMPORTANT: Solvent vapors from dry-cleaning machines create acids when drawn through the heater of the drying unit. These acids are corrosive to the dryer as well as to the laundry load being dried. Be sure make-up air is free of solvent vapors.**

**IMPORTANT: Have your dryer installed properly. Don't do it yourself unless you know how!**

**NOTE: The WARNING and IMPORTANT SAFETY INSTRUCTIONS appearing in this manual are not meant to cover all possible conditions and situations that may occur. Common sense, caution and care must be exercised when installing, maintaining, or operating the dryer.**

Always contact your dealer, distributor, service agent or the manufacturer about any problems or conditions you do not understand.

# Installation

## Dimensions

### Nonmetered Models

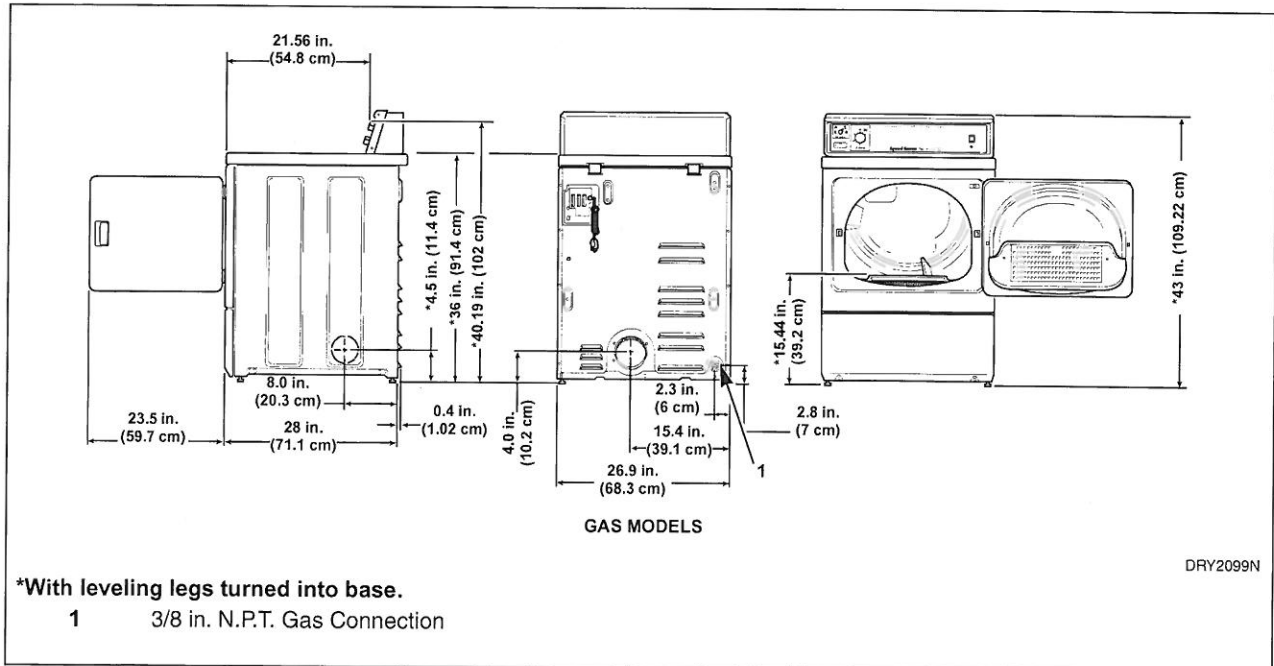
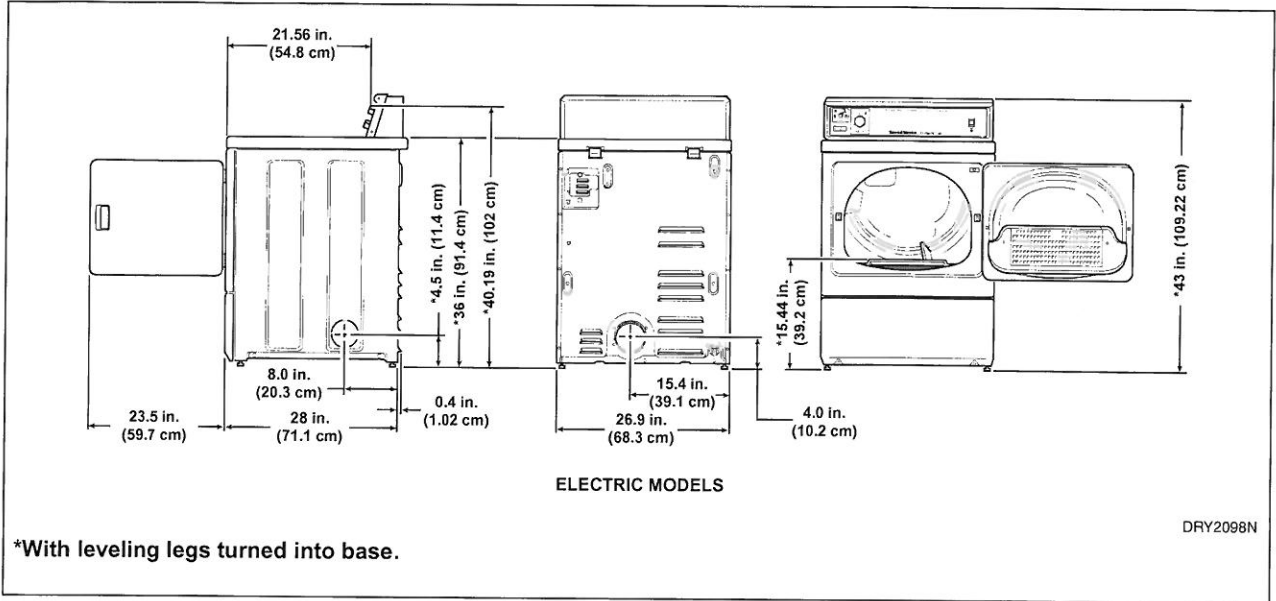

Metered Models

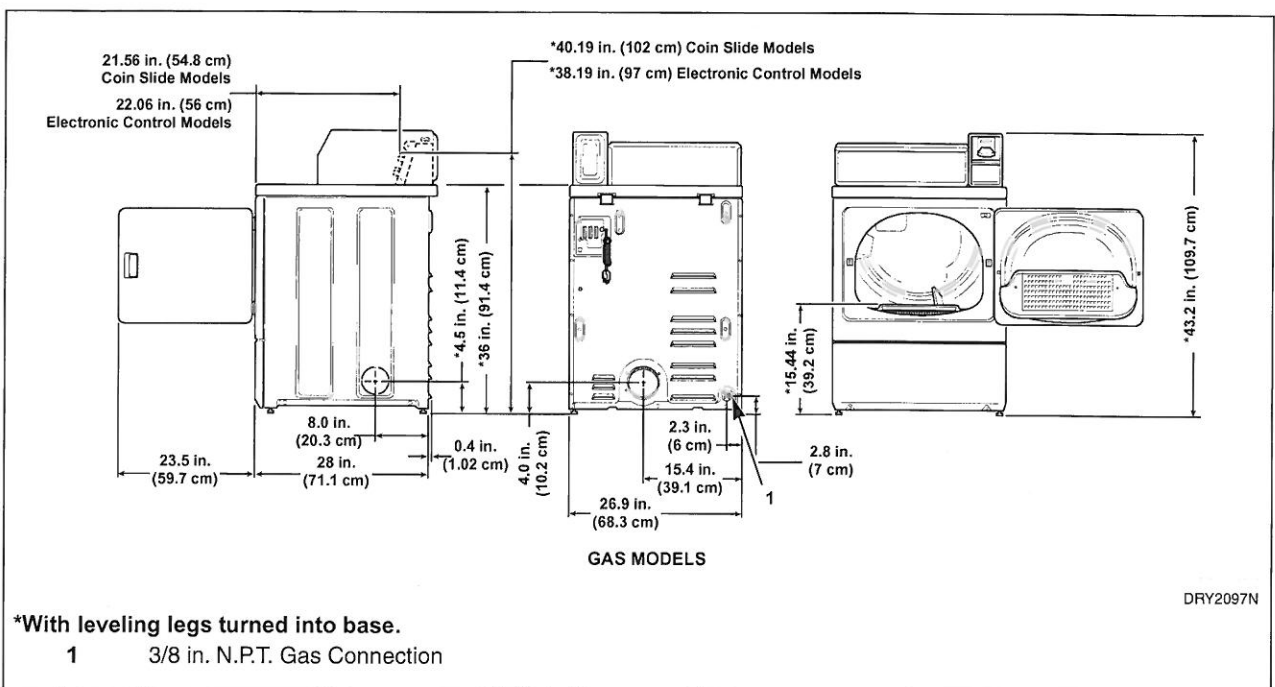
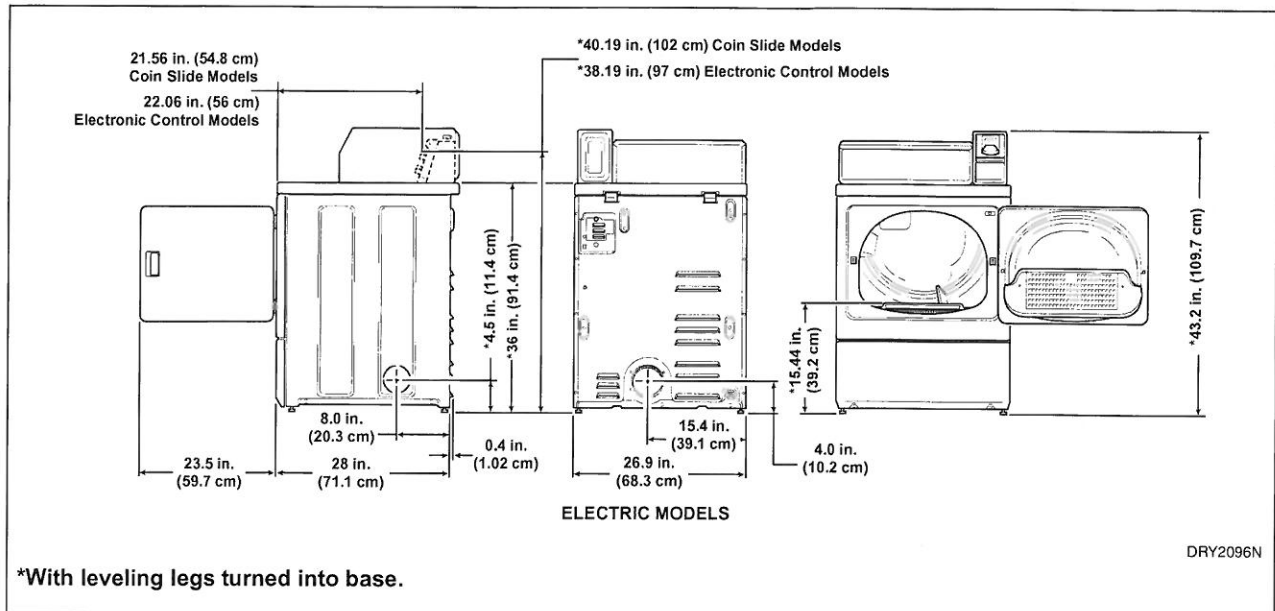

**NOTE:** Side, rear and bottom exhaust openings are 4 inch (10.2 cm) ducting. Gas models cannot be vented out left side of cabinet because of burner housing.

**IMPORTANT:** The dryer should have sufficient clearance around it for needed ventilation and for the ease of installation and servicing. For maximum drying performance, we recommend that more clearance be allowed around the dryer than the clearances that are listed throughout this manual.

## Installation

### Before You Start

#### Tools

For most installations, the basic tools you will need are:

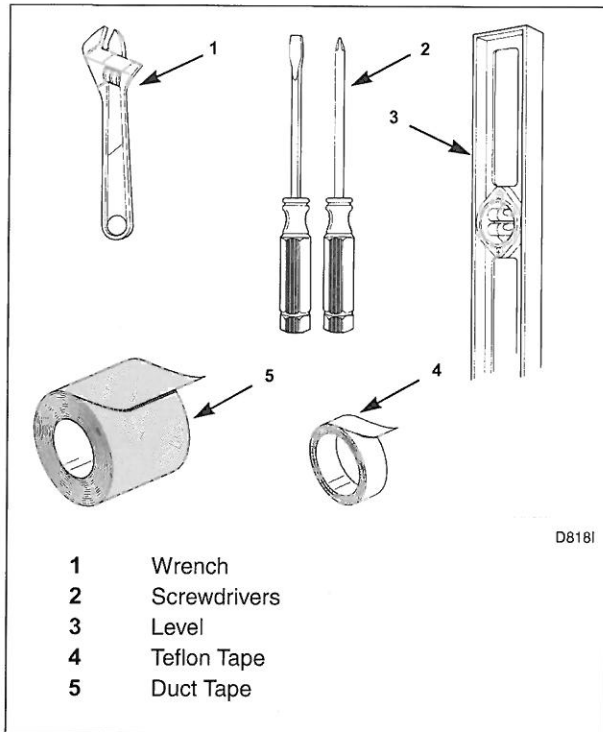

Figure 1

**NOTE:** An 8 in. (20.32 cm) coin drawer is required for coin operated MDC and NetMaster models.

#### Card Reader Models

The machine is shipped from the factory with the Electronic Control Diagnostic Harness Assembly unplugged. To avoid unauthorized manual programming or vending perform the following steps.

1. Open service door. Refer to *Figure 1*.
2. Locate diagnostic harness on electronic control.
3. Plug connectors for “white/black” wire and “red/blue” wire together.

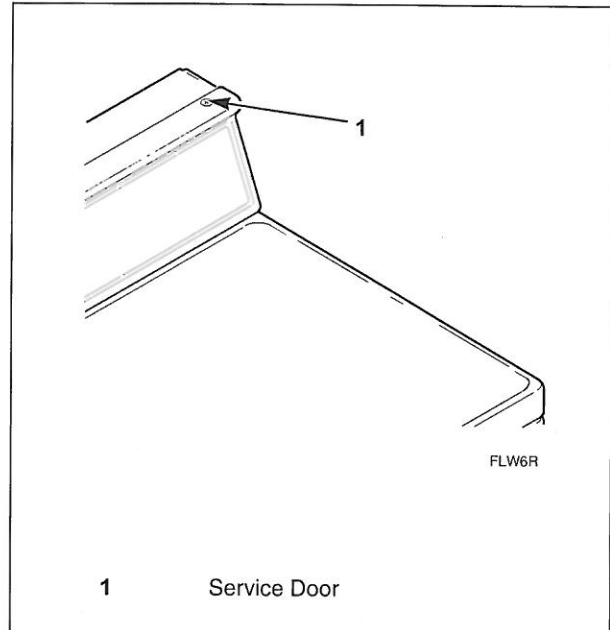

Figure 2



### WARNING

Any disassembly requiring the use of tools must be performed by a suitably qualified service person.

W299

## Installing the Dryer

### Step 1: Position and Level the Dryer

Install dryer before washer. This allows room for attaching exhaust duct.

Install the four rubber feet (in accessories bag).

Select a location with a solid floor. Dryers installed in residential garages must be elevated 18 inches (46 cm) above the floor.

No other fuel burning appliance should be installed in the same closet with the dryer.

The dryer must not be installed or stored in an area where it will be exposed to water and/or weather.

The dryer needs sufficient clearance and an adequate air supply for proper operation and ventilation, and for easier installation and servicing. (Minimum clearances are shown in *Figure 4*).

Place the dryer in position, and adjust the legs until the dryer is level from side to side and front to back. Leveling legs can be adjusted from inside the dryer with a 1/4 in. driver. All four legs must rest firmly on the floor so the weight of the dryer is evenly distributed. The dryer must not rock.

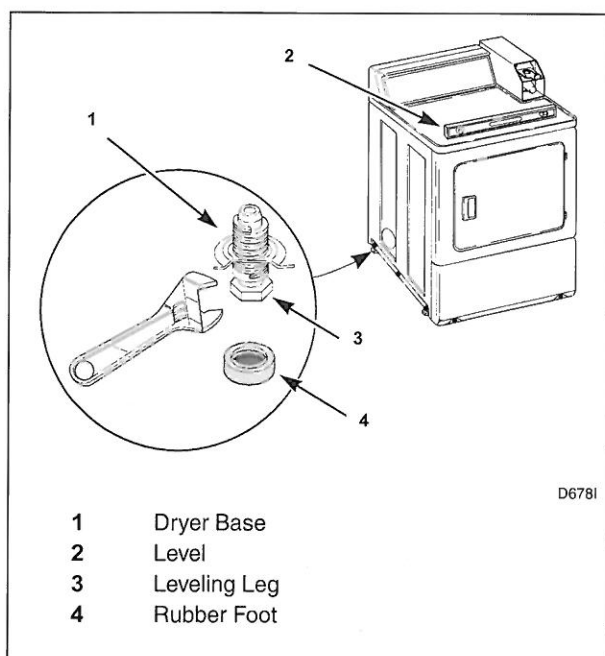

Figure 3

**IMPORTANT:** In mobile home installations, gas dryers **MUST** be permanently attached to the floor at the time of installation. Order No. 526P3 Hold Down Kit (available at extra cost) for a manufactured (mobile) home installation. Follow the instructions supplied with the kit.

Installation of unit must conform to the Manufactured Home Construction and Safety Standards, Title 24 CF4, Part 32-80 or Standard CAN/CSA-Z240 MH.



# Installation

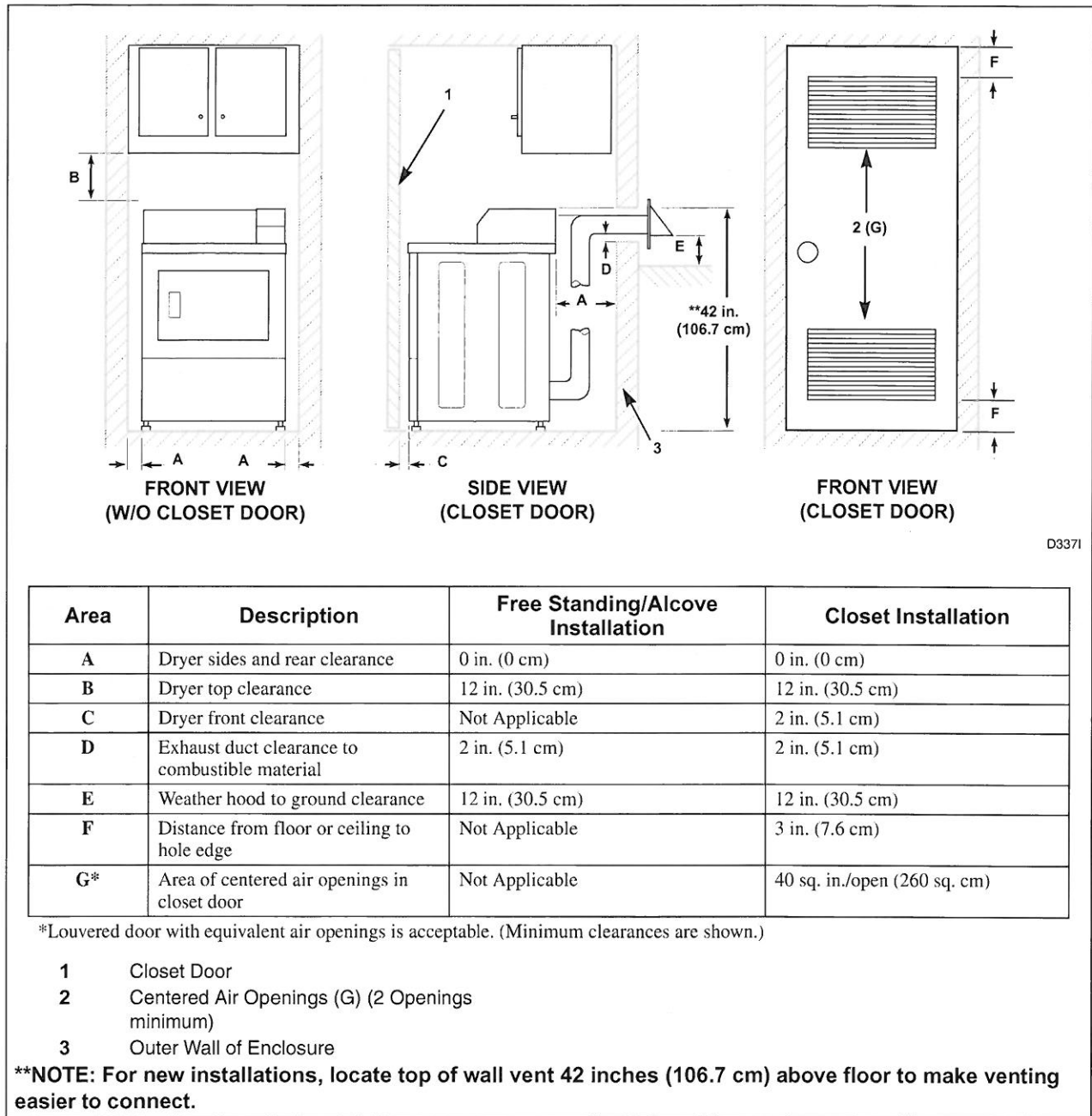



Figure 4

**Step 2: Connect Dryer Exhaust System**

	<b>WARNING</b>
<p>To reduce the risk of fire and combustion gas accumulation the dryer <b>MUST</b> be exhausted to the outdoors.</p> <p style="text-align: right;">W604</p>	
<p>To reduce the risk of fire and the accumulation of combustion gases, <b>DO NOT</b> exhaust dryer air into a window well, gas vent, chimney or enclosed, unventilated area, such as an attic, wall, ceiling, crawl space under a building or concealed space of a building.</p> <p style="text-align: right;">W045</p>	

	<b>WARNING</b>
<p>This gas appliance contains or produces a chemical or chemicals which can cause death or serious illness and which are known to the State of California to cause cancer, birth defects, or other reproductive harm. To reduce the risk from substances in the fuel or from fuel combustion, make sure this appliance is installed, operated, and maintained according to the instructions in this manual.</p> <p style="text-align: right;">W115</p>	
<p>To reduce the risk of fire, <b>DO NOT</b> use plastic or thin foil ducting to exhaust the dryer.</p> <p style="text-align: right;">W354</p>	
<p>To reduce the risk of fire, the exhaust duct and weather hood <b>MUST</b> be fabricated of a material that will not support combustion. Rigid or flexible metal pipe is recommended for a clothes dryer.</p> <p style="text-align: right;">W048</p>	

- **DO NOT** use plastic or thin foil ducting. Rigid metal duct is recommended.

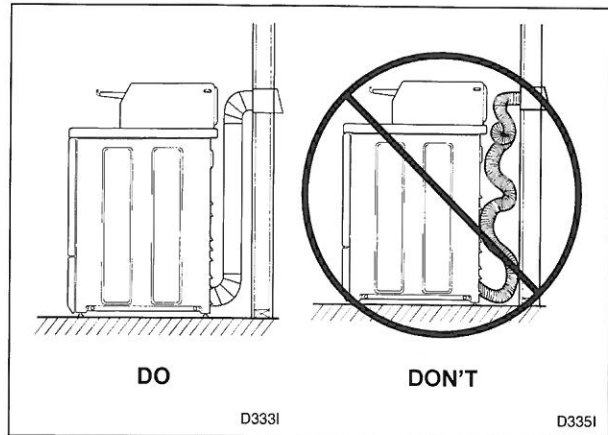

Figure 5

- Locate dryer so exhaust duct is as short as possible.
- Be certain old ducts are cleaned before installing your new dryer.
- Use 4 inch (102 mm) diameter rigid or flexible metal duct.
- The male end of each section of duct must point away from the dryer.
- Use as few elbows as possible.
- Use duct tape or pop-rivets on all duct joints. **DO NOT** use sheet metal screws or fasteners on exhaust pipe joints which extend into the duct.
- Ductwork that runs through unheated areas must be insulated to help reduce condensation and lint build-up on pipe walls.
- Install backdraft dampers in multi-dryer installations.
- In mobile home installations, dryer exhaust duct must be secured to mobile home structure.
- Dryer exhaust duct **MUST NOT** terminate under mobile home.
- Dryer exhausts 220 cfm (measured at back of dryer).
- **DO NOT** install flexible duct in concealed spaces, such as a wall or ceiling.

## Installation

- Static pressure in exhaust duct should not be greater than .6 inches water column (1.5 cm), measured with manometer placed on exhaust duct two feet (61 cm) from dryer (check with dryer running and no load). In multi-dryer installations, all dryers connected to the main collector duct should be operating when pressure is checked.
- Exhausting dryer in hard-to-reach locations can be done by installing 521P3 Flexible Metal Vent Kit (available as optional equipment at extra cost).
- Sufficient make-up air must be supplied to replace the air exhausted by the dryer. The free area of any opening for outside air must be at least 40 in<sup>2</sup> (260 cm<sup>2</sup>).
- Energy efficient buildings with low air infiltration rates should be equipped with an air exchanger that can accommodate on demand make-up air needs in the laundry room. These devices can be obtained through your building contractor or building material suppliers.
- Do not draw make-up air from a room containing a gas fired water heater, a dry cleaner or a hair salon.
- **Failure to exhaust dryer properly will void warranty.**

**NOTE: Venting materials are not supplied with the dryer (obtain locally).**

**IMPORTANT: DO NOT block the airflow at the bottom of the dryer's front panel with laundry, rugs, etc. Blockage will decrease airflow through the dryer, thus reducing the efficiency of the dryer.**

## Exhaust Direction

The dryer can be exhausted to the outdoors through the back, left, right or bottom of the dryer. **EXCEPTION: Gas dryers cannot be vented out the left side because of the burner housing.**

Dryer is shipped from factory ready for rear exhaust.

Exhausting the dryer through sides or bottom can be accomplished by installing a Directional Exhaust Kit, 528P3, available as optional equipment at extra cost.

### Exhaust System

For best drying results, recommended maximum length of exhaust system is shown in *Table 1*.

To prevent backdraft when dryer is not in operation, outer end of exhaust pipe must have a weather hood with hinged dampers (obtain locally).

**NOTE:** Weather hood should be installed at least 12 inches (30.5 cm) above the ground. Larger clearances may be necessary for installations where heavy snowfall can occur.

Number of 90° Elbows	Weather Hood Type	
	Recommended	Use Only for Short Run installations
	 <p>4 in. (10.2 cm)</p> <p>4 in. (10.2 cm)</p> <p>D673I</p>	 <p>2-1/2 in. (6.35 cm)</p> <p>D802I</p>
<b>Maximum length of 4 in. (10.2 cm) diameter rigid metal duct.</b>		
0	65 feet (19.8 m)	55 feet (16.8 m)
1	55 feet (16.8 m)	47 feet (14.3 m)
2	47 feet (14.3 m)	41 feet (12.5 m)
3	36 feet (11.0 m)	30 feet (9.1 m)
4	28 feet (8.5 m)	22 feet (6.7 m)
<b>Maximum length of 4 in. (10.2 cm) diameter flexible metal duct.</b>		
0	45 feet (13.7 m)	35 feet (10.7 m)
1	35 feet (10.7 m)	27 feet (8.2 m)
2	30 feet (9.1 m)	21 feet (6.4 m)
3	25 feet (7.6 m)	17 feet (5.2 m)
4	20 feet (6.1 m)	15 feet (4.5 m)
<b>NOTE: Deduct 6 feet (1.8 m) for each additional elbow.</b>		

Table 1

## Installation

### Multi-Dryer Installation Exhaust Requirements

Figure 6 shows a typical example of a multiple dryer installation. Note how each dryer has its own exhaust system vented to the central exhaust duct.

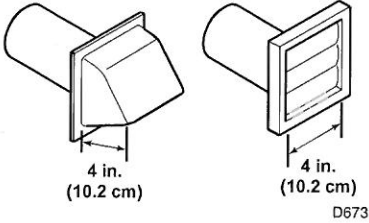
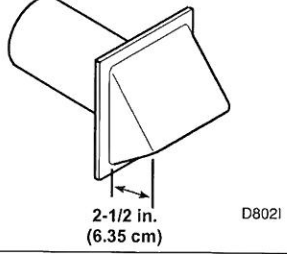
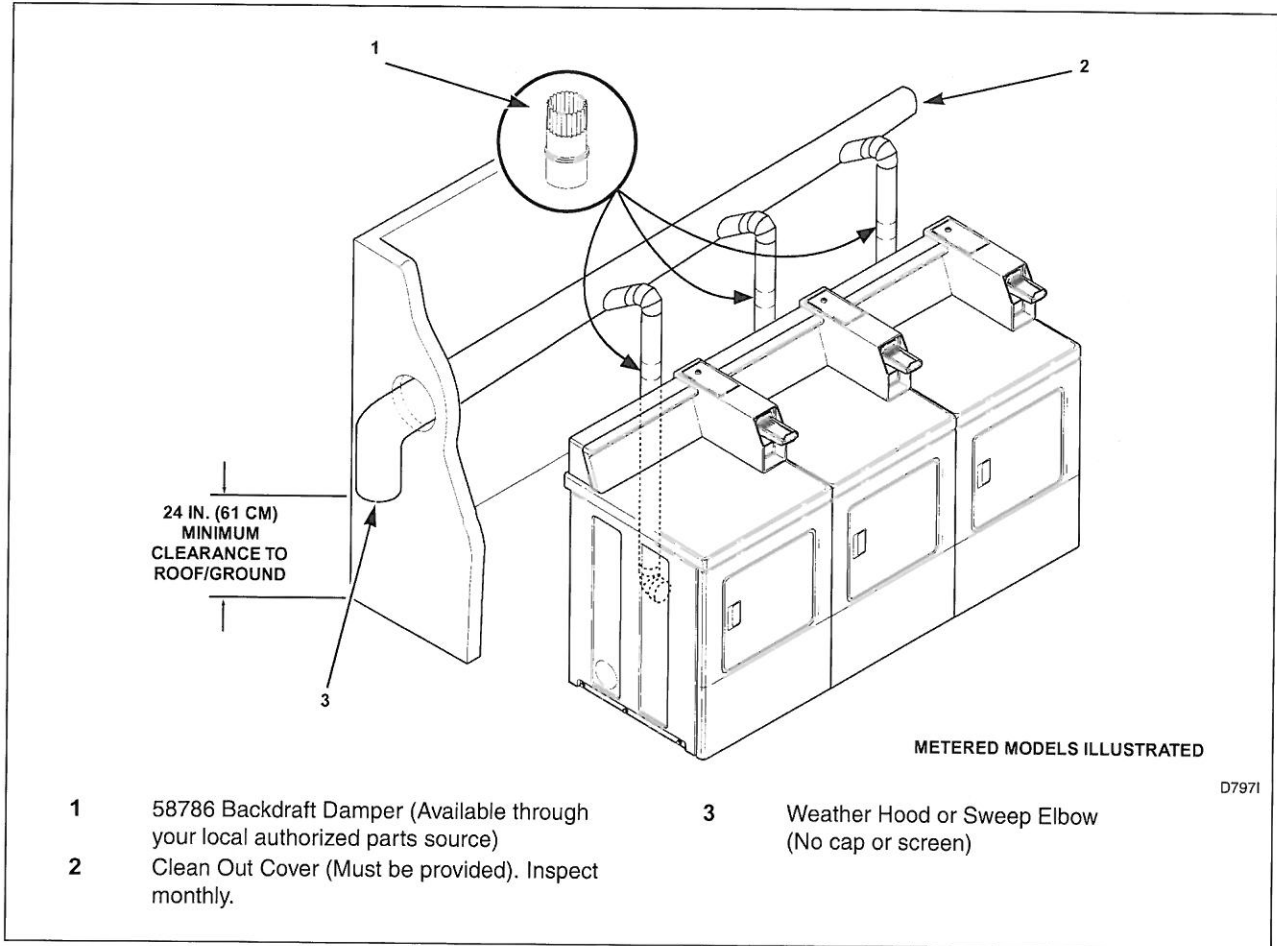

Figure 6

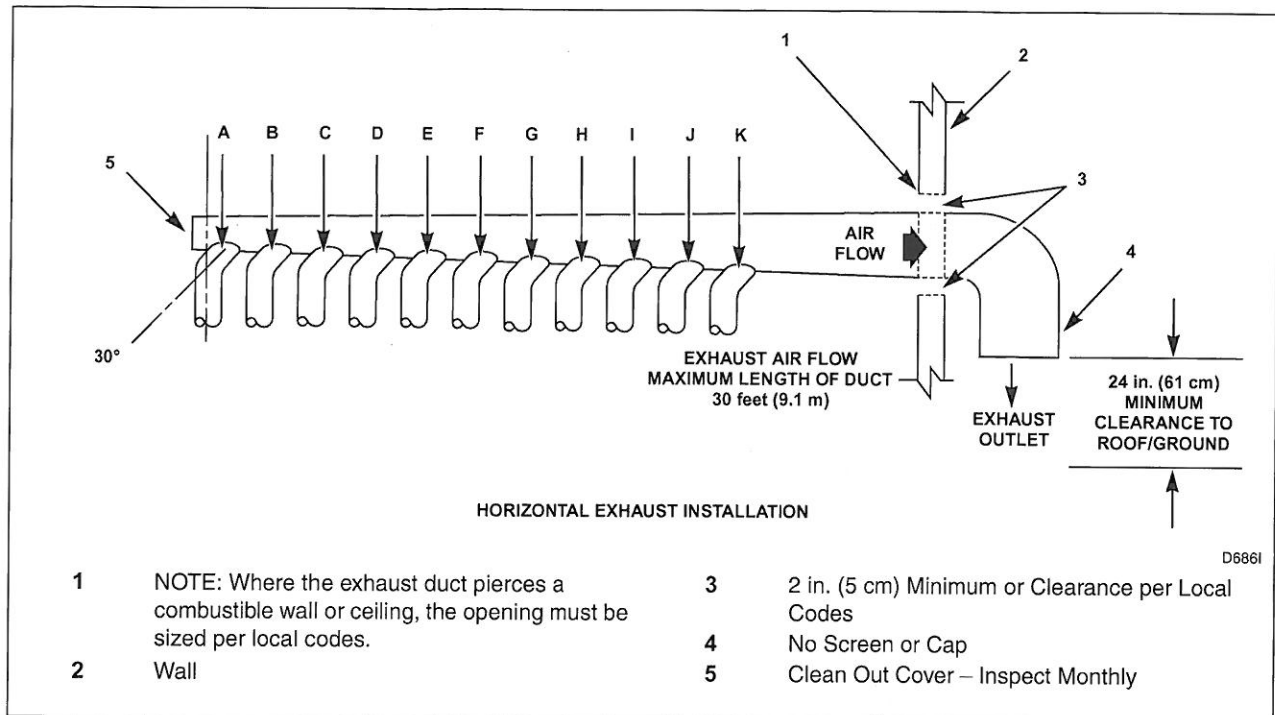

Figure 7

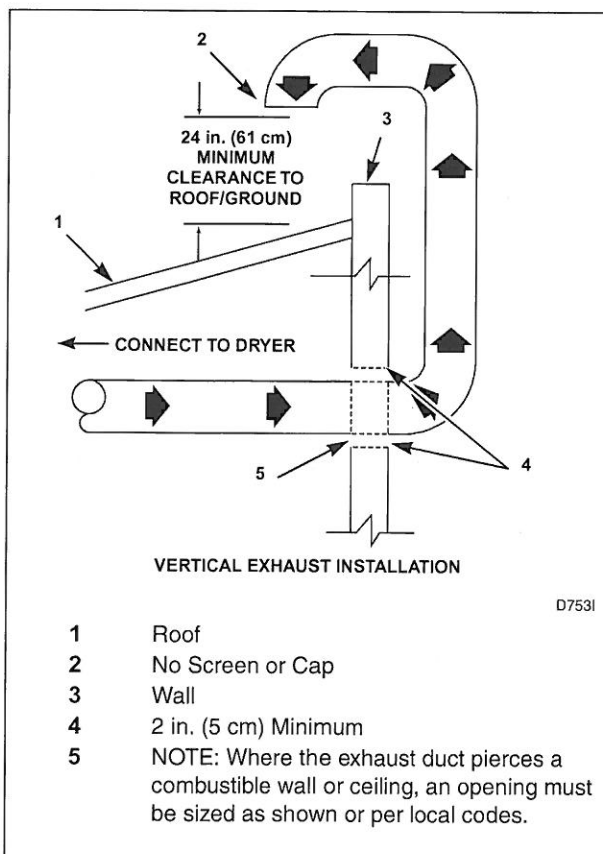

Figure 8

## WARNING

**To reduce the risk of fire and the accumulation of combustion gases, DO NOT exhaust dryer air into a window well, gas vent, chimney or enclosed, unventilated area, such as an attic, wall, ceiling, crawl space under a building or concealed space of a building.**

W045

## Installation

Duct Station	Minimum Diameter of Collector Duct
A	4 inches (10.2 cm)
B	8 inches (20.3 cm)
C	9 inches (22.9 cm)
D	10 inches (25.4 cm)
E	11 inches (27.9 cm)
F	12 inches (30.5 cm)
G	13 inches (32.6 cm)
H	14 inches (35.6 cm)
I	15 inches (38.1 cm)
J	15 inches (38.1 cm)
K	16 inches (40.6 cm)

A Backdraft Damper, Part No. 58786 (obtain locally), should be installed in a 4 inch (10.2 cm) diameter VERTICAL duct system. This will prevent a backdraft when dryer is not in use, and will keep the exhaust air in balance within the central exhaust system.

### Step 3: (Gas Dryer Only) Connect Gas Supply Pipe

	<b>WARNING</b>
<p><b>To reduce the risk of gas leaks, fire or explosion:</b></p> <ul style="list-style-type: none"> <li>• The dryer must be connected to the type of gas as shown on nameplate located in the door recess.</li> <li>• Use a new flexible stainless steel connector.</li> <li>• Use pipe joint compound insoluble in L.P. (Liquefied Petroleum) Gas, or Teflon tape, on all pipe threads.</li> <li>• Purge air and sediment from gas supply line before connecting it to the dryer. Before tightening the connection, purge remaining air from gas line to dryer until odor of gas is detected. This step is required to prevent gas valve contamination.</li> <li>• Do not use an open flame to check for gas leaks. Use a non-corrosive leak detection fluid.</li> <li>• Any disassembly requiring the use of tools must be performed by a suitably qualified service person.</li> </ul>	
W316	

1. Make certain your dryer is equipped for use with the type of gas in your laundry room. Dryer is equipped at the factory for **Natural Gas** with a 3/8 inch NPT gas connection.

**NOTE: The gas service to a gas dryer must conform with the local codes and ordinances, or in the absence of local codes and ordinances, with the latest edition of the National Fuel Gas Code ANSI Z223.1/NFPA 54 or the CAN/CGA-B149, National Gas Installation Code.**

**Natural Gas**, 1000 Btu/ft<sup>3</sup> (37.3 MJ/m<sup>3</sup>) service must be supplied at 6.5 ± 1.5 inch water column pressure.

For proper operation at altitudes above 2000 feet (610 m) the natural gas valve spud orifice size must be reduced to ensure complete combustion. Refer to *Table 2*.

<b>Natural Gas Altitude Adjustments</b>					
<b>Altitude</b>		<b>Orifice Size</b>			<b>Part Number</b>
<b>feet</b>	<b>m</b>	<b>#</b>	<b>inches</b>	<b>mm</b>	
2,000	610	41	0.0960	2.44	503776
3,000	915	42	0.0935	2.37	503777
5,500	1,680	43	0.0890	2.26	503778
7,000	2,135	44	0.0860	2.18	58719
9,000	2,745	45	0.0820	2.08	503779
10,500	3,200	46	0.0810	2.06	503780

Table 2

2. Remove the shipping cap from the gas connection at the rear of the dryer. Make sure you do not damage the pipe threads when removing the cap.

**NOTE:** When connecting to a gas line, an equipment shut-off valve must be installed within 6 feet (1.8 m) of the dryer. An 1/8 in. NPT pipe plug must be installed as shown for checking inlet pressure. Refer to *Figure 9*.

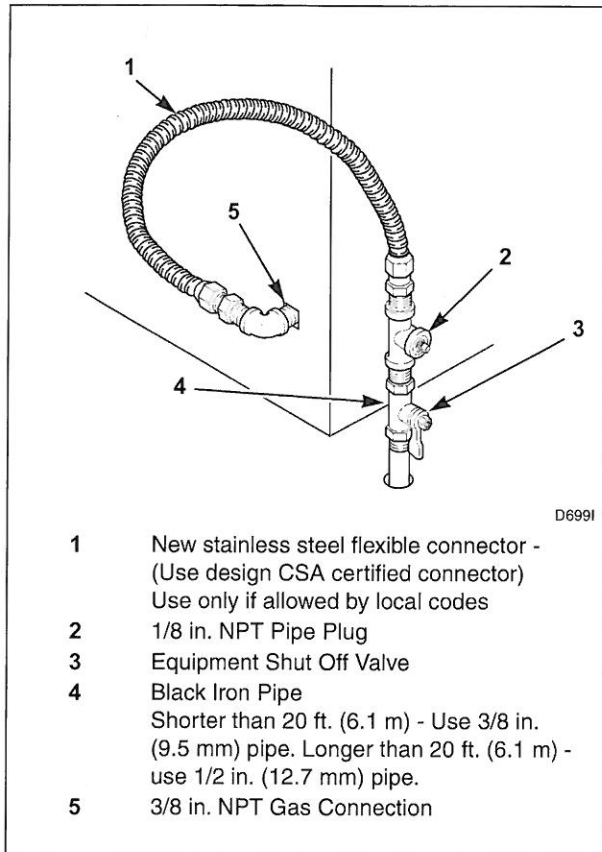

Figure 9

3. Tighten all connections securely. Turn on gas and check all pipe connections (internal & external) for gas leaks with a non-corrosive leak detection fluid.

**NOTE:** The dryer and its appliance main gas valve must be disconnected from the gas supply piping system during any pressure testing of that system at test pressures in excess of 1/2 psi (3.45 kPa). Refer to *Step 9 (Check Heat Source)*.

**L.P. (Liquefied Petroleum) Gas, 2500 Btu/ft<sup>3</sup> (93.1 MJ/m<sup>3</sup>)** service must be supplied at 10 ± 1.5 inch water column pressure.

For proper operation at altitudes above 3500 feet (1070 m) the L.P. gas valve spud orifice size must be reduced to ensure complete combustion. Refer to *Table 3*.

L.P. Altitude Adjustments					
Altitude		Orifice Size			Part No.
feet	m	No.	inches	mm	
3500	1070	54	0.0550	1.40	503785
7500	2290	55	0.0520	1.32	58755
11000	3355	56	0.0465	1.18	503786

Table 3

**NOTE: DO NOT** connect the dryer to L.P. Gas Service without converting the gas valve. Install L.P. Gas Conversion Kit 458P3, available at extra cost.

**Step 4: (Electric Dryer Only) Connect Electrical Plug**

Dryer requires 120/240 Volt or 120/208 Volt, 60 Hertz, 3 or 4 wire electrical supply. Refer to serial plate for specific electrical requirements.

**NOTE:** The wiring diagram is located inside the control hood.

WARNING

**To reduce the risk of fire, electric shock, serious injury or death, all wiring and grounding MUST conform with the latest edition of the National Electrical Code, ANSI/NFPA 70, or the Canadian Electrical Code, CSA C22.1, and such local regulations as might apply. It is the customer's responsibility to have the wiring and fuses installed by a qualified electrician to make sure adequate electrical power is available to the dryer.**

W521



## Installation

### *Grounding Information*

- This dryer must be connected to a grounded metal, permanent wiring system; or an equipment-grounding conductor must be run with the circuit conductors and connected to the equipment-grounding terminal or lead on the dryer.
- The dryer has its own terminal block that must be connected to a separate branch, 60 Hertz, single phase circuit, AC (alternating current) circuit, **fused at 30 Amperes** (the circuit must be fused on both sides of the line). **Electrical service for the dryer should be of maximum rated voltage listed on the nameplate. Do not connect dryer to 110, 115, or 120 volt circuit.**
- Heating elements are available for field installation in dryers which are to be connected to electrical service of different voltage than that listed on nameplate, such as 208 Volt.
- If branch circuit to dryer is 15 feet (4.57 m) or less in length, No. 10 AWG wire (copper wire only), or as required by local codes. If over 15 feet (4.57 m), use No. 8 AWG wire (copper wire only), or as required by local codes. Allow sufficient slack in wiring so dryer can be moved from its normal location when necessary.
- The power cord connection between wall receptacle and dryer terminal block **IS NOT supplied with dryer.** Type of power cord and gauge of wire must conform to local codes.

**IMPORTANT:** Use only a new U.L. listed No. 10 (copper wire only) three conductor power supply cord kit rated 240 Volts (minimum) 30 Amperes and labeled as suitable for use in a clothes dryer.

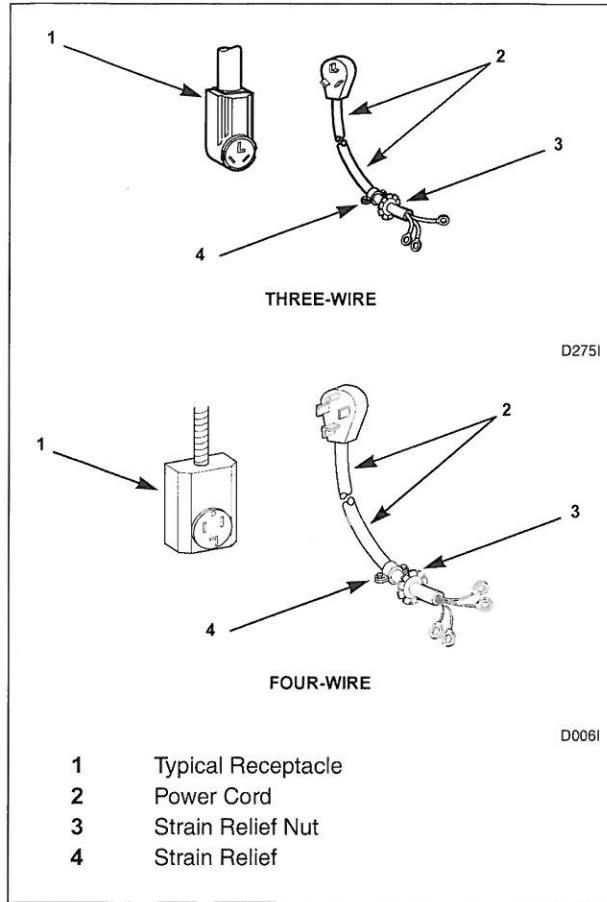

Figure 10

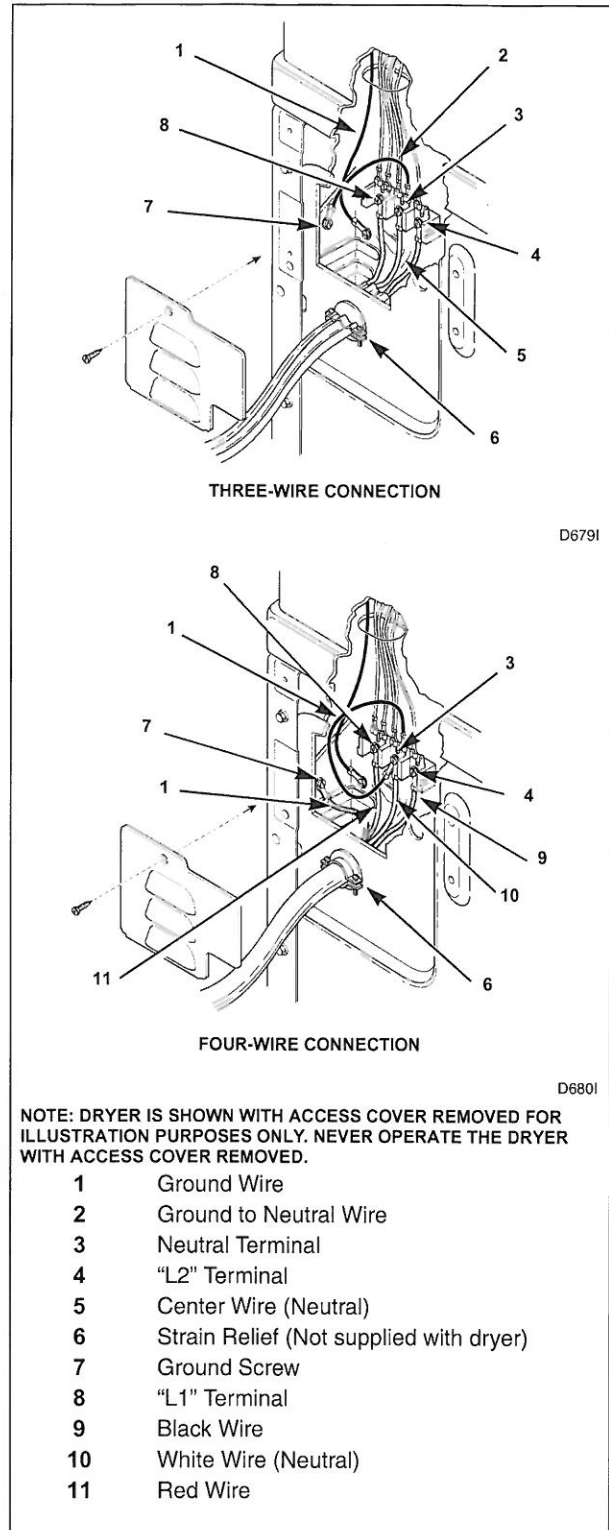

Figure 11

**Installation**

*Connecting Power Cord with Three-Wire Plug*

**NOTE: Four-wire cord is required for mobile homes or where codes do not permit grounding through neutral.**

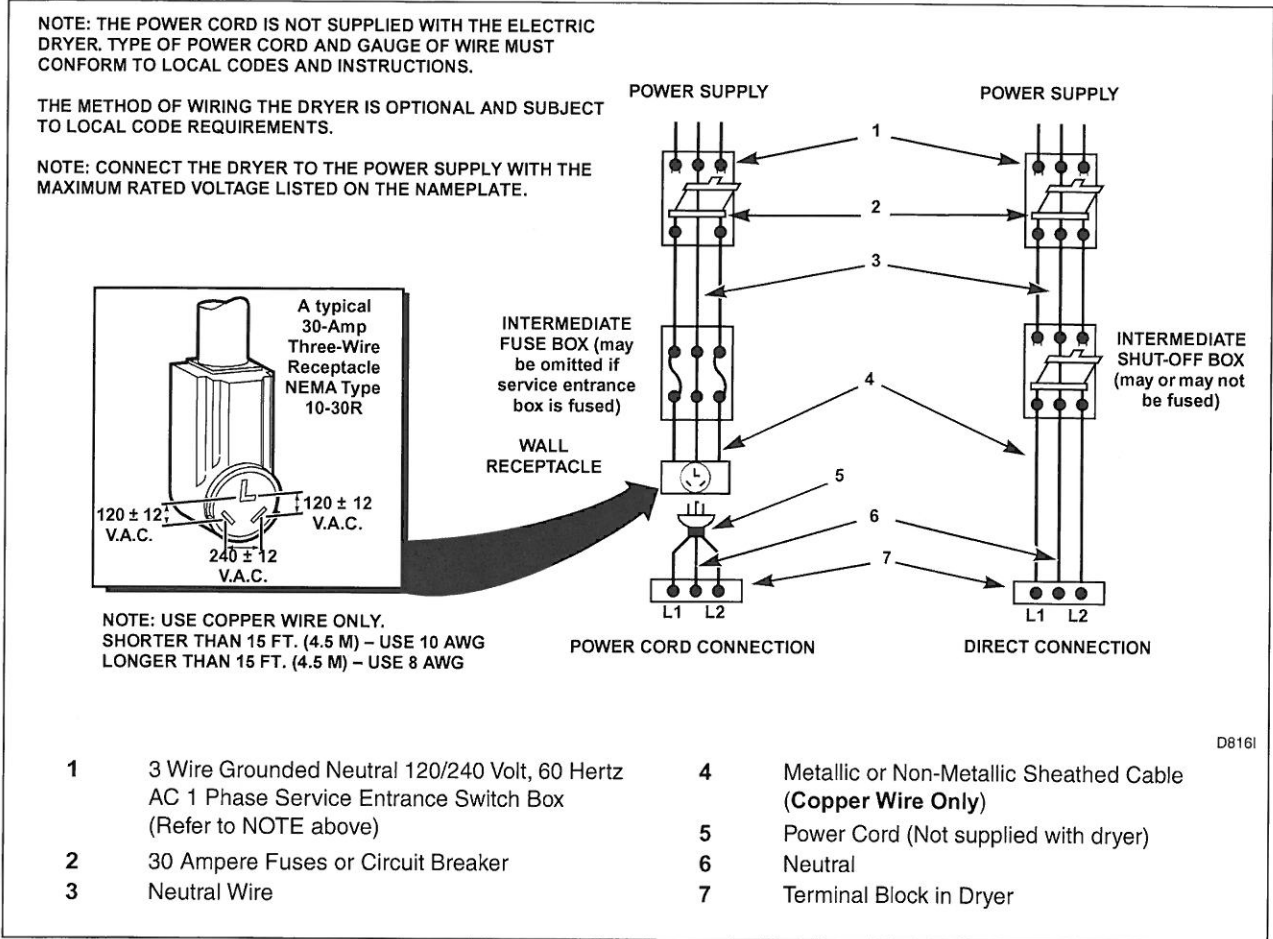

Figure 12

1. Disconnect power to dryer.
2. Remove access cover from rear of dryer.
3. Use a strain relief and insert end of power cord through power supply hole.

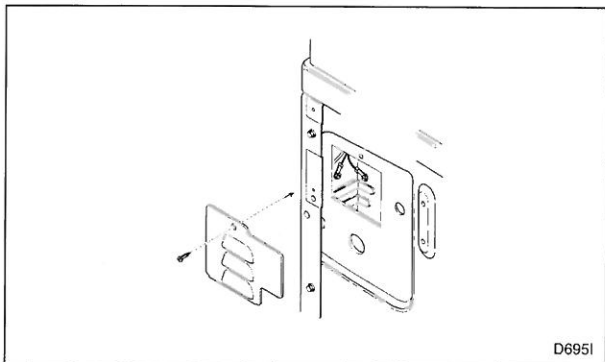

Figure 13

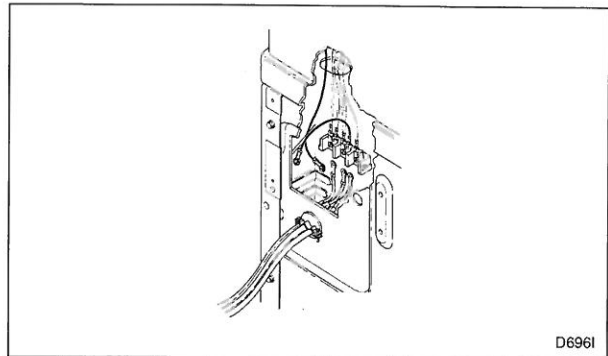

Figure 14

- 4. Use the three screws from the accessories bag to attach the power cord wires to the terminal block. Refer to *Figure 15*.

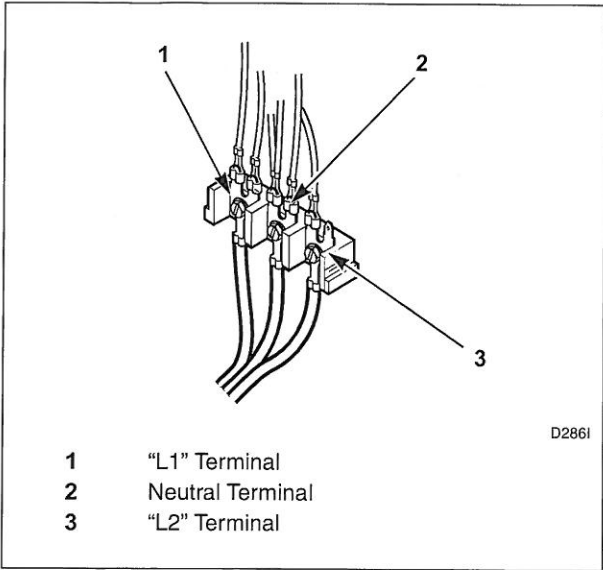

Figure 15

- 5. Tighten all screws firmly.

**IMPORTANT: Failure to tighten these screws firmly may result in wire failure at the terminal block.**

- 6. Secure the strain relief to the power cord, or wires, where they enter the dryer cabinet.
- 7. Check the continuity of the ground connection before plugging the cord into an outlet. Use an acceptable indicating device connected to the center grounding pin of the plug and the green screw on the back of the cabinet.
- 8. Reinstall access cover and screw.

*Connecting Power Cord with Four-Wire Plug*

**NOTE: Four-wire cord is required for mobile homes or where codes do not permit grounding through neutral.**

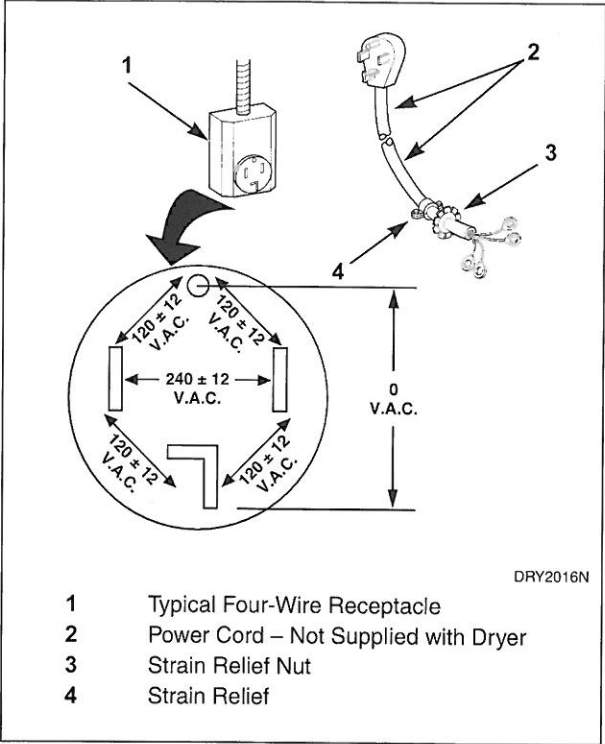

Figure 16

## Installation

1. Disconnect power to dryer.
2. Remove access cover from rear of dryer.

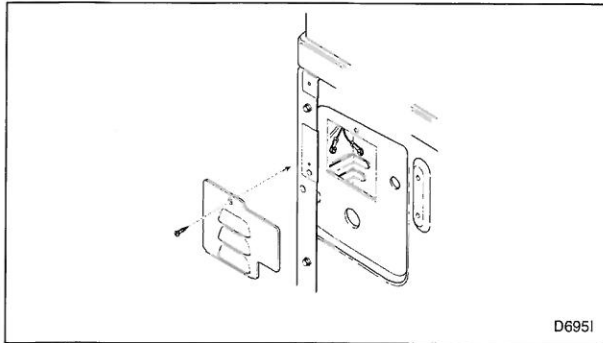

Figure 17

3. Remove ground screw and save for use in Step 5. Remove wire and use in Step 6.

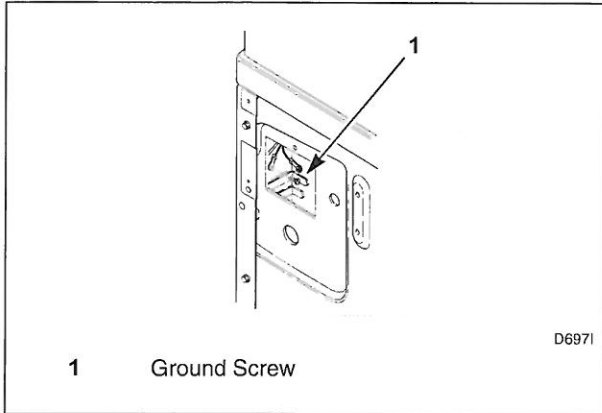

Figure 18

4. Use a strain relief and insert end of power cord through power supply hole.

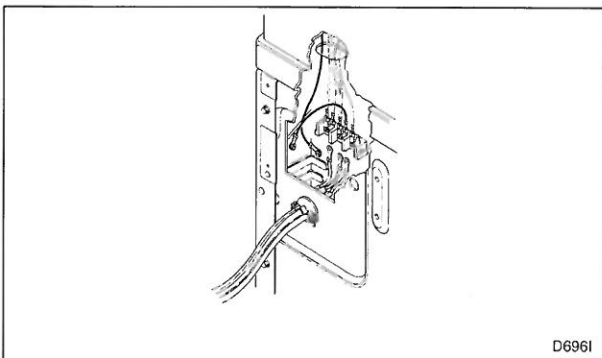

Figure 19

5. Attach power cord ground (green) wire to rear bulkhead using ground screw removed in Step 3.

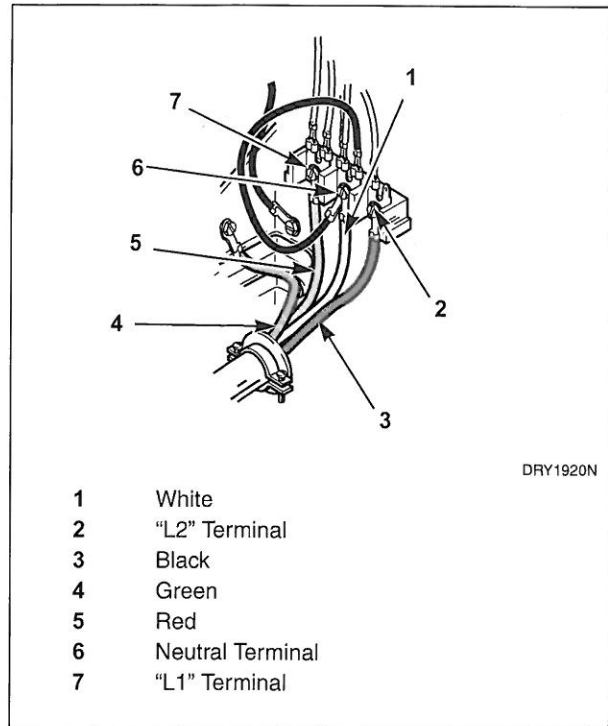

Figure 20

6. Use the three screws from the accessories bag to attach the remaining power cord wires to the terminal block as follows:
  - a. Red wire to "L1" terminal.
  - b. Black wire to "L2" terminal.
  - c. White wire to Neutral terminal.
7. Tighten all screws firmly.

**NOTE:** When installing the white wire, loop the free eyelet end of the ground wire (removed in Step 3) and attach along with the white wire to the neutral (center) terminal on the terminal block.

**IMPORTANT:** Failure to tighten these screws firmly may result in wire failure at the terminal block.

8. Secure the strain relief to the power cord, or wires, where they enter the dryer cabinet.
9. Check the continuity of the ground connection before plugging the cord into an outlet. Use an acceptable indicating device connected to the center grounding pin of the plug and the green screw on the back of the cabinet.
10. Reinstall access cover and screw.

**Step 5: Reverse Door, if Desired**

The door on this dryer is completely reversible. To reverse door proceed as follows:

- 1. Remove four hinge attaching screws.

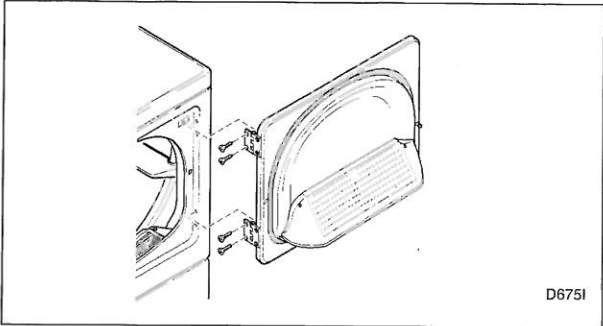

Figure 21

- 2. Remove all nine screws.

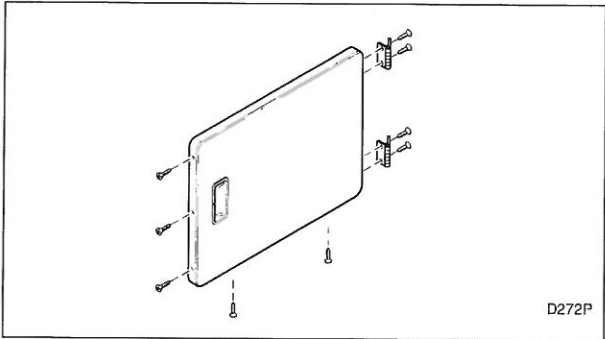

Figure 22

- 3. Pull bottom of door liner out, then pull down, removing door liner from door panel.

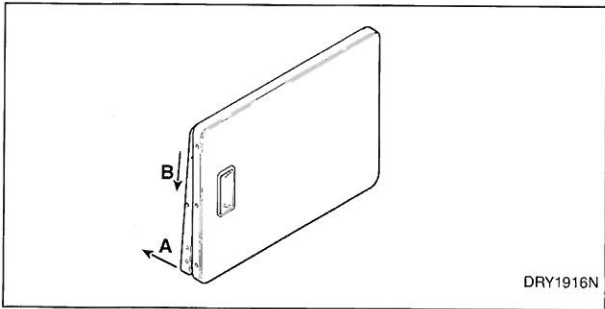

Figure 23

- 4. Rotate door panel 180 degrees as shown.

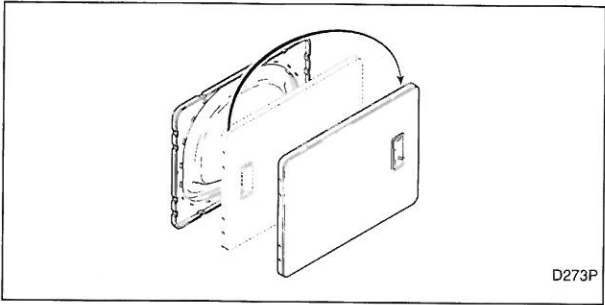

Figure 24

- 5. Remove door strike from door liner and reinstall on opposite side.

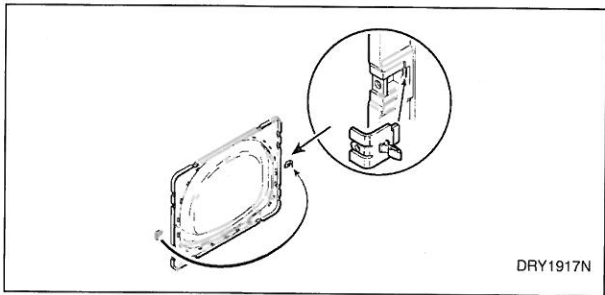

Figure 25

- 6. Insert liner under flange on bottom of door, then push top of door liner into place.

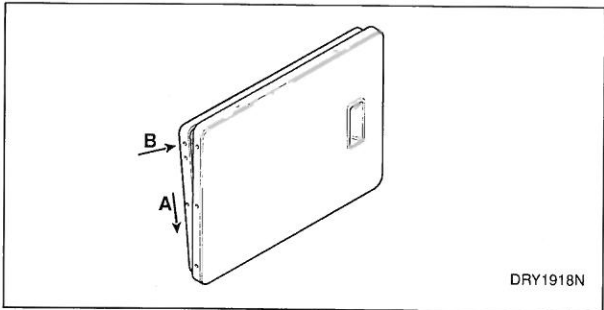

Figure 26

- 7. Reinstall nine screws removed in Step 2.

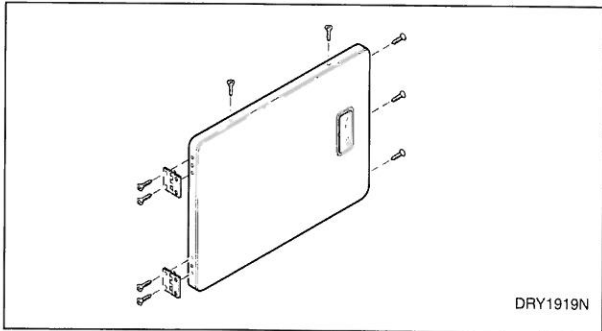

Figure 27

## Installation

- Using screwdriver, remove two door plugs, and reinstall on opposite side of door opening.

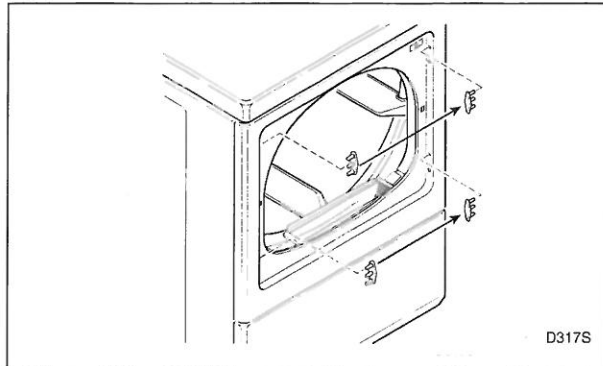

Figure 28

- Reinstall four hinge attaching screws, removed in Step 1.

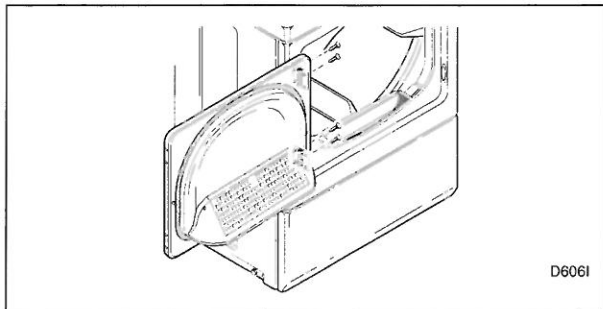

Figure 29

### Step 6: Wipe Out Inside of Dryer

Before using dryer for the first time, use an all-purpose cleaner, or a detergent and water solution, and a damp cloth to remove shipping dust from inside dryer drum.

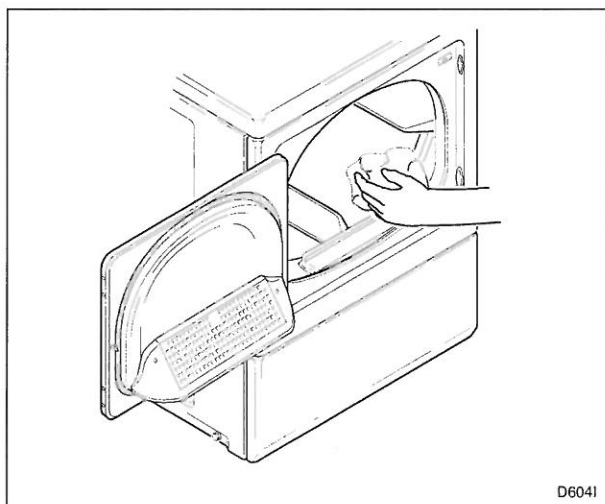

Figure 30

### Step 7: Plug In the Dryer

#### Electric Dryer

Connect the dryer to an electrical power source. Refer to Step 4 for information on connecting power cord.

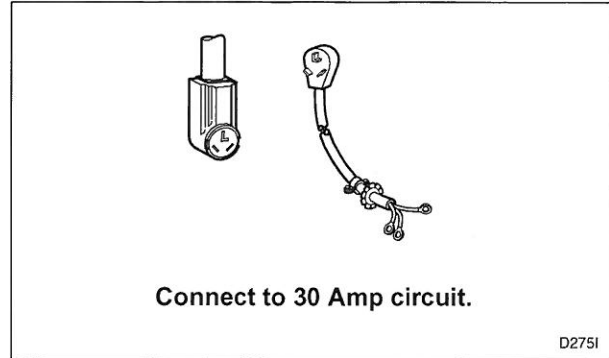

Figure 31

#### Gas Dryer

Dryer requires 120 Volt, 60 Hertz electrical supply and comes equipped with a 3-prong grounding plug. Refer to serial plate for specific electrical requirements.

**NOTE:** The wiring diagram is located inside the control hood.



## WARNING

To reduce the risk of fire, electric shock, serious injury or death, all wiring and grounding **MUST** conform with the latest edition of the National Electrical Code, ANSI/NFPA 70, or the Canadian Electrical Code, CSA C22.1, and such local regulations as might apply. It is the customer's responsibility to have the wiring and fuses installed by a qualified electrician to make sure adequate electrical power is available to the dryer.

W521

When plugging in the dryer:

- Do not overload circuits.
- Do not use an adapter.
- Do not use an extension cord.
- Do not operate both a washer and gas dryer on the same circuit. Use separately fused 15 amp circuits.

The dryer is designed to be operated on a separate branch, polarized, three-wire, effectively grounded, 120 Volt, 60 Hertz, AC (alternating current) circuit protected by a **15 Ampere fuse**, equivalent fuse-tron or circuit breaker.

The three-prong grounding plug on the power cord should be plugged directly into a polarized three-slot effectively grounded receptacle rated 120 Volts AC (alternating current) 15 Amps. Refer to *Figure 32* to determine correct polarity of the wall receptacle.

**Grounding Information**

The dryer must be grounded. In the event of malfunction or breakdown, grounding will reduce the risk of electric shock by providing a path of least resistance for electric current. The dryer is equipped with a cord having an equipment-grounding conductor and a 3 prong grounding plug. The three-prong grounding plug on the power cord should be plugged directly into a polarized three-slot effectively grounded receptacle rated 110/120 Volts AC (alternating current) 15 Amps.

Do not operate other appliances on the same circuit when this appliance is operating.

	<b>WARNING</b>
<p><b>To reduce the risk of an electric shock or fire, DO NOT use an extension cord or an adapter to connect the dryer to the electrical power source.</b></p>	
W037	

	<b>WARNING</b>
<p><b>This dryer is equipped with a three-prong (grounding) plug for your protection against shock hazard and should be plugged directly into a properly grounded three-prong receptacle. Do not cut or remove the grounding prong from this plug.</b></p>	
W036	

	<b>WARNING</b>
<p><b>Improper connection of the equipment-grounding conductor can result in a risk of electric shock. Check with a qualified electrician or service person if you are in doubt as to whether the dryer is properly grounded.</b></p>	
W038	

Do not modify the plug provided with the dryer – if it will not fit the outlet, have a proper outlet installed by a qualified electrician.

**NOTE: Have a qualified electrician check the polarity of the wall receptacle. If a voltage reading is measured other than that illustrated, the qualified electrician should correct the problem.**

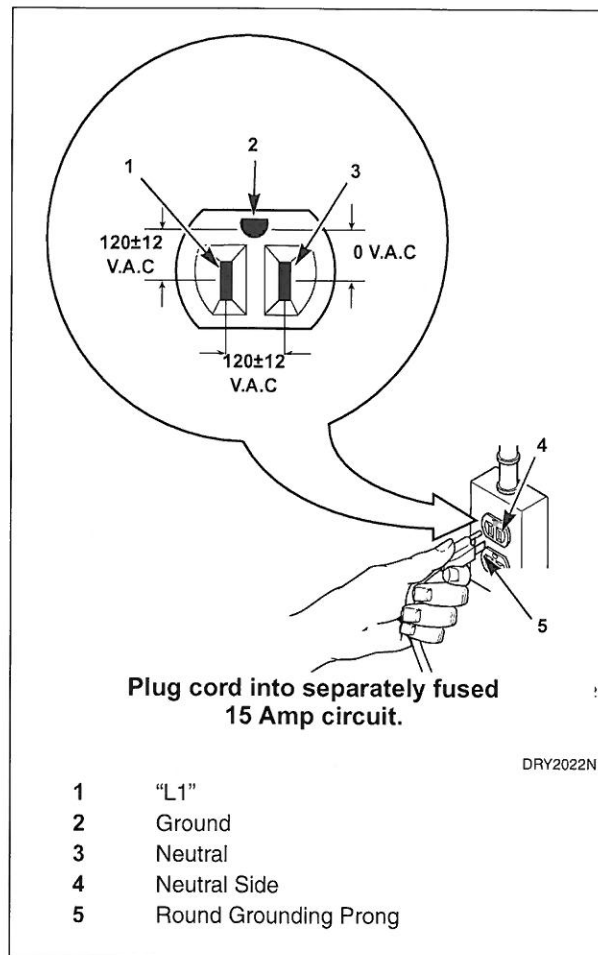

Figure 32

- 1 "L1"
- 2 Ground
- 3 Neutral
- 4 Neutral Side
- 5 Round Grounding Prong



## Installation

### Step 8: Recheck Steps 1-7

Refer to *Installer Checklist* on the back cover of this manual and make sure that dryer is installed correctly.

### Step 9: Check Heat Source

#### Electric Dryers

Close the loading door and start the dryer in a heat setting (refer to the *Operation* section). After the dryer has operated for three minutes, the exhaust air or exhaust pipe should be warm.

#### Gas Dryers

**IMPORTANT: This operation is to be conducted by qualified personnel only.**

To view the burner flame, remove the lower front panel of the dryer.

Close the loading door, start the dryer in a heat setting (refer to the *Operation* section). The dryer will start, the igniter will glow red and the main burner will ignite.

**IMPORTANT: If all air is not purged out of gas line, gas igniter may go off before gas is ignited. If this happens, after approximately two minutes igniter will again attempt gas ignition.**

**IMPORTANT: If igniter does not light, make sure gas is turned on.**

After the dryer has operated for approximately five minutes, observe burner flame through lower front panel. Adjust the air shutter to obtain a soft, uniform blue flame. (A lazy, yellow-tipped flame indicates lack of air. A harsh, roaring, very blue flame indicates too much air.) Adjust the air shutter as follows:

1. Loosen the air shutter lockscrew.
2. Turn the air shutter to the left to get a luminous yellow-tipped flame, then turn it back slowly to the right to obtain a steady, soft blue flame.
3. After the air shutter is adjusted for proper flame, tighten the air shutter lockscrew securely.
4. Reinstall the lower front panel.

	<b>WARNING</b>
<b>For personal safety, lower front panel must be in place during normal operation.</b>	
<small>W046</small>	

After the dryer has operated for approximately three minutes, exhaust air or exhaust pipe should be warm.

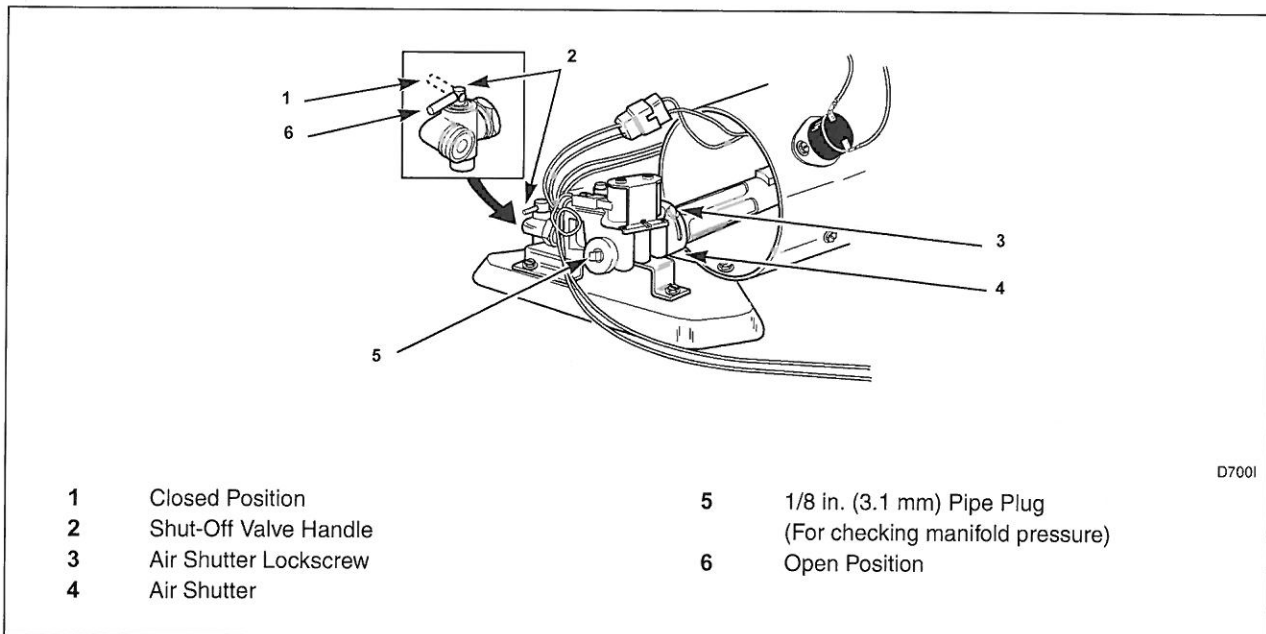

Figure 33

# Vending

## Meter Case

### (Metered Models)

The factory mounted coin meter case does not include the service door lock, coin drawer, coin drawer lock and keys. These parts must be ordered (at extra cost) according to the purchaser's requirements direct from the manufacturer of your choice.

**NOTE: You have the option of using a screw type lock or a 1/4 turn lock on the meter case service door. If you choose to use a screw lock, then the special bracket (located inside the meter case) must be used. DO NOT use the special bracket if a 1/4 turn lock is used.**

**Coin Drawer Security** – for additional security, drill out the two pilot holes on each front side of the meter case to 1/4 or 5/16 inch (6.4 or 8.0 mm) holes and install a bicycle lock through these holes.

## Coin Slide Control

### (Coin Slide Models Only)

#### Power-Up Mode

When power is applied to the dryer, the control will enter the Ready Mode. If the control was powered down during a running a cycle, the *IN USE* LED will flash once and the control will enter Start Mode. If the dry time dipswitch settings have not been changed from factory default, the *IN USE* LED will flash once.

#### Ready Mode

In Ready Mode, the control waits for the vend to be satisfied before entering Start Mode.

#### Start Mode

In Start Mode, the vend has been satisfied, but the Start button has not been pressed. The *IN USE* LED will be lit. The timer will not count down until the Start button is pressed.

#### Run Mode

In Run Mode, the control is running a cycle. The *IN USE* LED is lit.

#### Door Open Mode

In Door Open Mode, the control turns off the heater and motor when the door is opened during a run cycle. The timer will continue to count down time and the *IN USE* LED is lit.

#### End of Cycle Mode

In End of Cycle Mode, a cycle is complete and the *IN USE* LED is off. The control remains in this mode until the door is opened or additional vend has been satisfied.

#### Topoffs

Any time the control receives a coin slide pulse during a cycle it will add the programmed dry time to the time currently remaining in the cycle. The *IN USE* LED will flash briefly to indicate the coin input. The maximum cycle time is 99 minutes. The control will not add time beyond 99 minutes. The cool down time will not change. If the control receives a coin slide pulse during cool down it will exit cool down and start heating with the cycle time equal to the programmed time.

#### Temperature Selector Switch

For five minutes after the control is powered up, there is a diagnostic feature that allows the temperature selector switches to be tested. When the temperature selector is changed, the new setting is displayed by flashing the *IN USE* LED as follows:

High/Normal: 4 flashes

Medium/PP or Casual: 3 flashes

Low/Delicate: 2 flashes

No Heat: 1 flash

## Vending

### Error Display Mode

The control enters Error Display Mode to display thermistor errors. The heater is turned off, the *IN USE* LED flashes to indicate the error (refer to paragraphs below), and the timer will continue to count down time. The control remains in Error Display Mode until the control senses the thermistor has returned to an acceptable heating range, the cycle ends or machine is powered down.

#### *Open Thermistor*

If the control senses a temperature less than 0°F when the heat has been on for at least three minutes it will set an open thermistor error. The control will flash the *IN USE* LED twice separated by a one and a half second pause. This sequence is repeated as long as the Open Thermistor error is sensed.

#### *Shorted Thermistor*

If the control senses a temperature greater than  $210 \pm 4$ °F during an active cycle it will set a Shorted Thermistor error. The control will flash the *IN USE* LED three times separated by a one and a half second pause. This sequence is repeated as long as the Shorted Thermistor error is sensed.

### Setting Dry Time Dipswitches

To change the dry time on the dryer, combinations of dipswitches can be set on the control. Refer to *Figure 34*.

There are eight dipswitches on the dryer control. The first six switches are used to program the amount of additional heat time given for each coin pulse. The additional drying time is added to the factory default minimum heat time of one minute. A value of 1 to 63 minutes of additional drying time is available for each coin slide pulse.

The last two switches are used to program the amount of additional cool down time. The additional cool down time is added to the factory default minimum cool down time of 3 minutes. A value of 1 to 3 additional minutes is available.

The control is shipped from the factory programmed with 1 minute of minimum heat time, preset with 41 additional minutes of drying time (dipswitches 1, 4 and 6 in ON position) and 3 minutes of minimum cool down time for a total time of 45 minutes for a coin pulse. Refer to *Table 4* for dipswitch settings.

The control reads the dipswitch settings at power-up. The control must be powered down to change the dipswitch settings.

To change the heat or cool down time for a coin pulse, the desired dry time dipswitches must be set to ON position. All other dipswitches must be in OFF position.

## Dipswitch Settings

Heat Time Per Coin Pulse (in minutes)	Heat Switch Number					
	1	2	3	4	5	6
1	OFF	OFF	OFF	OFF	OFF	OFF
2	ON	OFF	OFF	OFF	OFF	OFF
3	OFF	ON	OFF	OFF	OFF	OFF
4	ON	ON	OFF	OFF	OFF	OFF
5	OFF	OFF	ON	OFF	OFF	OFF
6	ON	OFF	ON	OFF	OFF	OFF
7	OFF	ON	ON	OFF	OFF	OFF
8	ON	ON	ON	OFF	OFF	OFF
9	OFF	OFF	OFF	ON	OFF	OFF
10	ON	OFF	OFF	ON	OFF	OFF
11	OFF	ON	OFF	ON	OFF	OFF
12	ON	ON	OFF	ON	OFF	OFF
13	OFF	OFF	ON	ON	OFF	OFF
14	ON	OFF	ON	ON	OFF	OFF
15	OFF	ON	ON	ON	OFF	OFF
16	ON	ON	ON	ON	OFF	OFF
17	OFF	OFF	OFF	OFF	ON	OFF
18	ON	OFF	OFF	OFF	ON	OFF
19	OFF	ON	OFF	OFF	ON	OFF
20	ON	ON	OFF	OFF	ON	OFF
21	OFF	OFF	ON	OFF	ON	OFF
22	ON	OFF	ON	OFF	ON	OFF
23	OFF	ON	ON	OFF	ON	OFF
24	ON	ON	ON	OFF	ON	OFF
25	OFF	OFF	OFF	ON	ON	OFF
26	ON	OFF	OFF	ON	ON	OFF
27	OFF	ON	OFF	ON	ON	OFF
28	ON	ON	OFF	ON	ON	OFF
29	OFF	OFF	ON	ON	ON	OFF
30	ON	OFF	ON	ON	ON	OFF
31	OFF	ON	ON	ON	ON	OFF
32	ON	ON	ON	ON	ON	OFF
33	OFF	OFF	OFF	OFF	OFF	ON
34	ON	OFF	OFF	OFF	OFF	ON
35	OFF	ON	OFF	OFF	OFF	ON
36	ON	ON	OFF	OFF	OFF	ON
37	OFF	OFF	ON	OFF	OFF	ON
38	ON	OFF	ON	OFF	OFF	ON

Table 4 (continued)

Vending

Table 4 (continued)

Heat Time Per Coin Pulse (in minutes)	Heat Switch Number					
	1	2	3	4	5	6
39	OFF	ON	ON	OFF	OFF	ON
40	ON	ON	ON	OFF	OFF	ON
41	OFF	OFF	OFF	ON	OFF	ON
42 (preset at factory)	ON	OFF	OFF	ON	OFF	ON
43	OFF	ON	OFF	ON	OFF	ON
44	ON	ON	OFF	ON	OFF	ON
45	OFF	OFF	ON	ON	OFF	ON
46	ON	OFF	ON	ON	OFF	ON
47	OFF	ON	ON	ON	OFF	ON
48	ON	ON	ON	ON	OFF	ON
49	OFF	OFF	OFF	OFF	ON	ON
50	ON	OFF	OFF	OFF	ON	ON
51	OFF	ON	OFF	OFF	ON	ON
52	ON	ON	OFF	OFF	ON	ON
53	OFF	OFF	ON	OFF	ON	ON
54	ON	OFF	ON	OFF	ON	ON
55	OFF	ON	ON	OFF	ON	ON
56	ON	ON	ON	OFF	ON	ON
57	OFF	OFF	OFF	ON	ON	ON
58	ON	OFF	OFF	ON	ON	ON
59	OFF	ON	OFF	ON	ON	ON
60	ON	ON	OFF	ON	ON	ON
61	OFF	OFF	ON	ON	ON	ON
62	ON	OFF	ON	ON	ON	ON
63	OFF	ON	ON	ON	ON	ON
64	ON	ON	ON	ON	ON	ON

Cool Down Per Cycle (in minutes)	Cool Down Switch Number	
	7	8
3 (preset at factory)	OFF	OFF
4	ON	OFF
5	OFF	ON
6	ON	ON

Table 4

Total Cycle Time = Heat Time + Cool Down Time

## Test Setting

When testing coin slide operation or other troubleshooting, set dipswitch with this shorter cycle:

1. Unplug the machine power cord.
2. Record the machine control dipswitch settings. Then set them all to the off position. Refer to *Figure 34*.

3. Plug in the machine and initiate a cycle.

**NOTE: With all the control dipswitches off, the total cycle time will be four minutes long.**

4. Once all the testing is complete, unplug the machine and re-set the dipswitches to their original settings.
5. Plug in the machine.

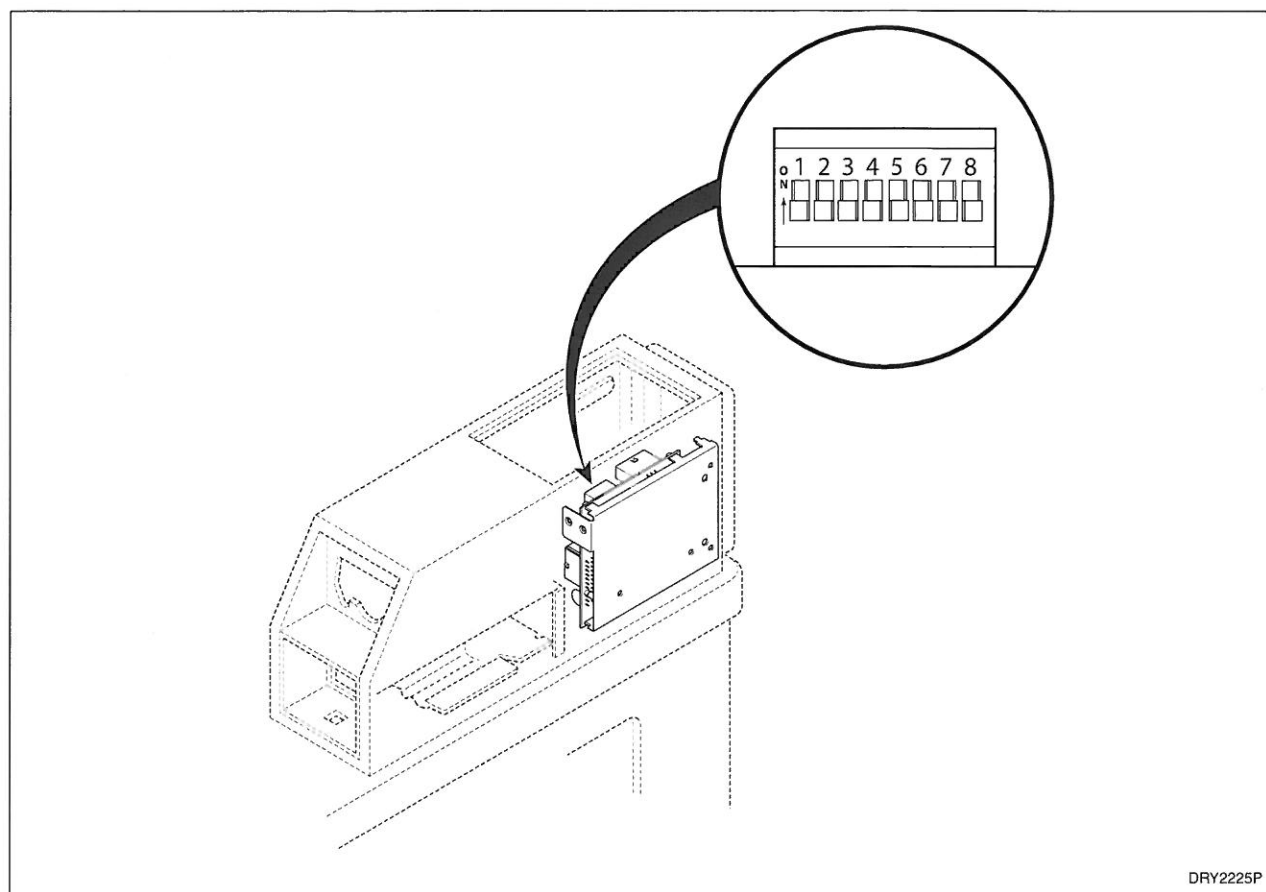

Figure 34

## Vending

### Slide Extension

#### (Coin Slide Models Only)

1. Remove slide extension parts from parts accessories bag included in unit.
2. If installing a Greenwald coin slide, position extension lever (to be installed on extension bracket) with arm that has one star facing down. Refer to *Figure 35*.

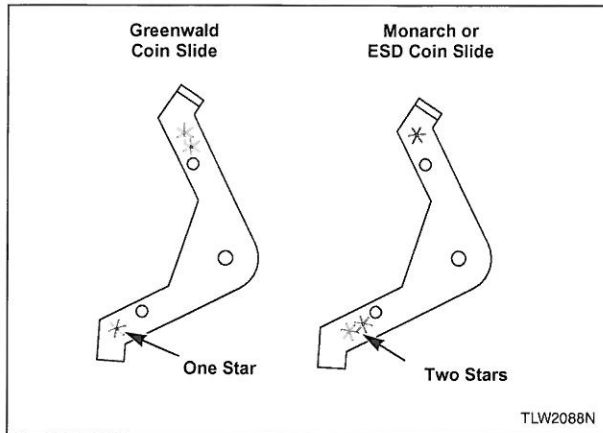

Figure 35

3. If installing a Monarch or ESD coin slide, position lever with arm that has two stars facing down. Refer to *Figure 35*.
4. Install extension lever with rounded corner facing away from extension bracket using bolt, one or two flat washers (shims) (use number of washers included in kit) and nut. Refer to *Figure 36*. Make sure washers are flat against bracket.

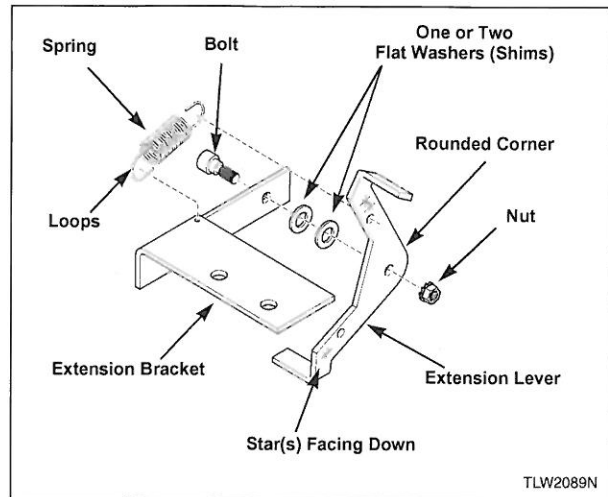

Figure 36

5. Torque nut between 2 and 2.26 Nm (18 and 20 inch-pounds), or tighten nut firmly.
6. Install extension spring in bracket hole and hole in upper arm of lever. Refer to *Figure 36*.
7. Bend loops closed after installation.
8. Check to make sure the lever swings freely.

*Installing Extension Onto Coin Slide:  
Option 1*

1. Install slide extension onto top of coin slide using two remaining screws and lockwashers. Refer to *Figure 37*.

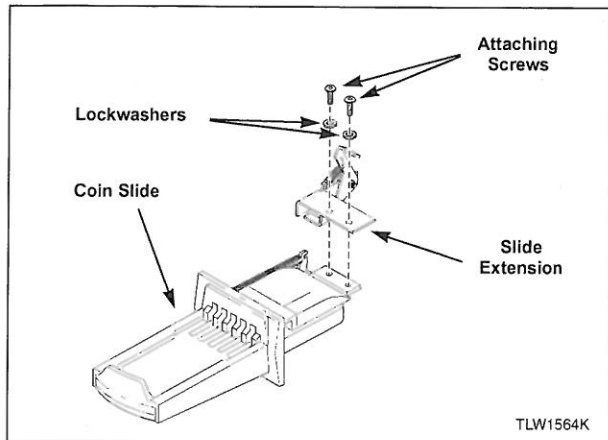

Figure 37

2. Insert coins and partially extend coin slide.
3. Insert coin slide on its side through meter case opening. Then rotate 90 degrees to its proper orientation.
4. Return coin slide and hook slide pins onto meter case.
5. Continue coin slide installation according to manufacturer's instructions.

**NOTE:** During coin slide installation, make sure activation lever is up and off the switch. Refer to *Figure 38*.

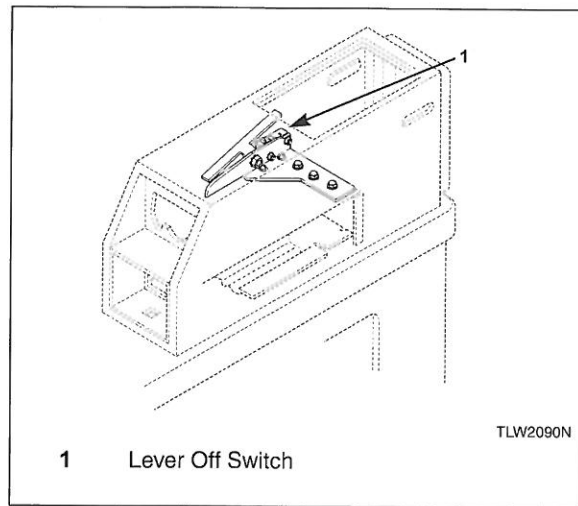

Figure 38

6. Check to make sure coin slide is operating properly by inserting coins and starting a cycle. The IN USE light will turn on, or flash if it is already on, to indicate proper operation.

**NOTE:** To avoid long run-down time (45 minutes factory default) when testing operation, refer to *Test Setting* section.

*Installing Extension Onto Coin Slide:  
Option 2*

1. Install coin slide according to manufacturer's instructions.
2. Insert coins into coin slide and slowly push slide in. Stop before coins fall into coin box. This will allow installing extension through meter case service door opening.
3. Install slide extension onto top of coin slide using two screws and lockwashers. Refer to *Figure 37*.

**NOTE:** Make sure extension lever is above switch activation lever.

4. Check to make sure coin slide is operating properly by inserting coins and starting a cycle. The IN USE light will turn on, or flash if it is already on, to indicate proper operation.

**NOTE:** To avoid long run-down time (45 minutes factory default) when testing operation, refer to *Test Setting* section.



## Vending

### Additional Dryer Security

Located on the service door of the dryer is a flat Phillips head screw. During shipment, this screw is used to attach the service door to the meter case. For additional security, this screw can be reinstalled inside the control hood of your dryer. Following is the procedure for installing this screw:

1. Remove the Phillips head screw from service door. (Refer to *Figure 39*.)
2. Remove two screws holding control panel to control hood.
3. Tilt control panel forward and lay on a protective pad to prevent scratching of cabinet top.
4. Insert Phillips head screw down through double "D" hole in left rear corner of cabinet top (inside control hood) until it engages retainer nut located on left rear corner gusset of cabinet.
5. Finger tighten screw.

**IMPORTANT: Do not use a power driver to tighten screw. Torque of a power driver could over-tighten screw causing damage to cabinet assembly.**

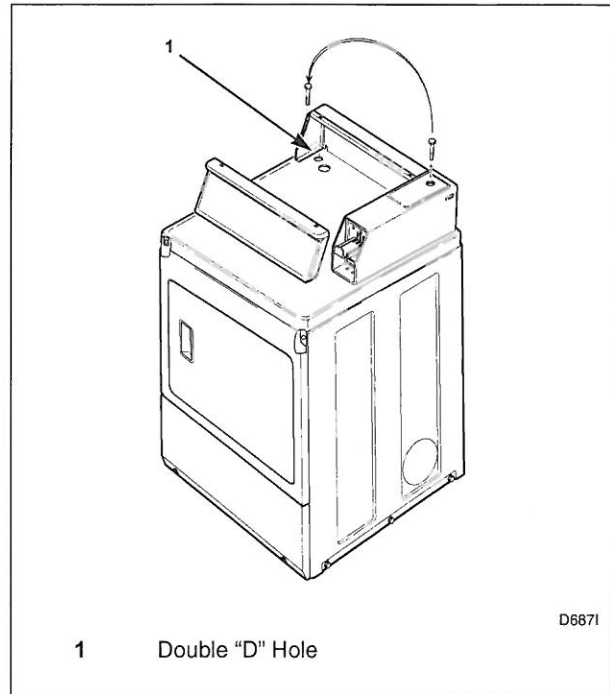

Figure 39

# Operation

## Operation Instructions for Nonmetered and Coin Slide Dryers

**IMPORTANT:** Before using dryer for the first time, use an all-purpose cleaner, or a detergent and water solution, and a damp cloth to remove shipping dust from inside of dryer drum.

**IMPORTANT:** Remove all sharp objects from laundry to avoid tears and rips to items during normal machine operation.

### Step 1: Clean Lint Filter

Clean lint filter before each use.

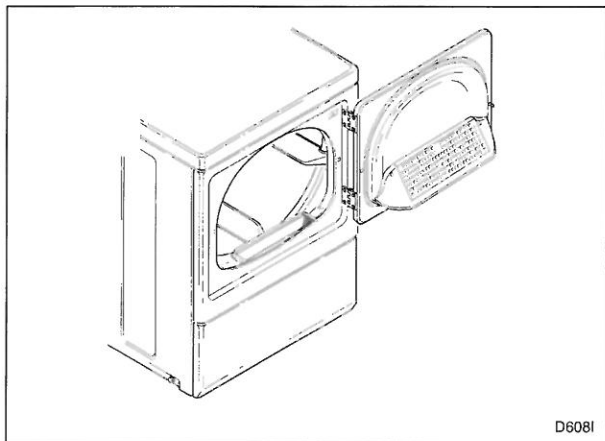

Figure 40

### Step 2: Load Laundry

Load clothes loosely into dryer drum. Add fabric softener sheet if desired.

**IMPORTANT:** To avoid damage to dryer, do not use more than one fabric softener sheet per load.

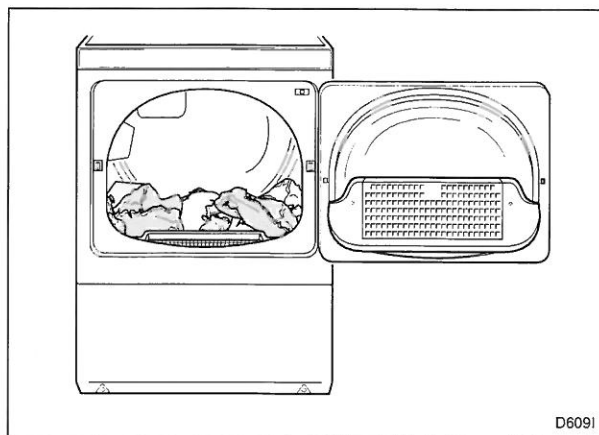

Figure 41

### Step 3: Close Loading Door

Close loading door. Dryer will not operate with the door open.

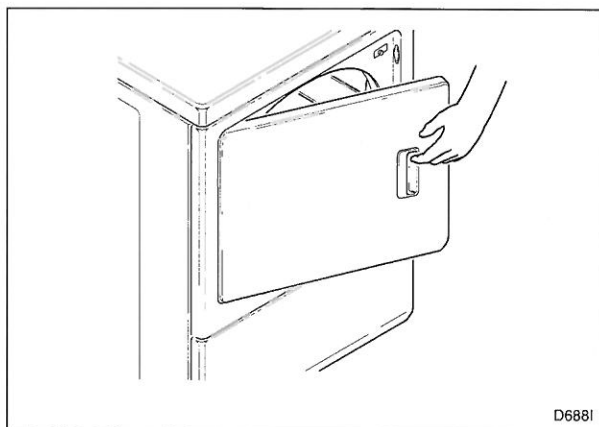

Figure 42

## Operation

### Step 4: Set Fabric Selector

Select **NORMAL** for cottons, **PERM PRESS/CASUAL** for permanent press, **DELICATE** for sensitive items or **FLUFF (NO HEAT)** for items that require no heat.

**NOTE: Always follow manufacturer's care label instructions.**

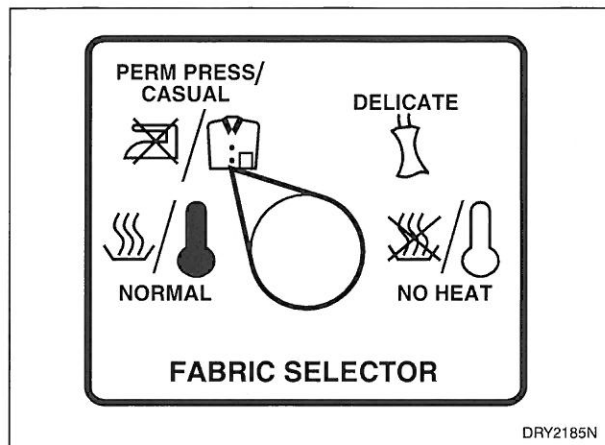

Figure 43

### Step 5: Start Dryer

#### Nonmetered Models

Rotate timer knob to desired time setting (up to 60 minutes). Press the PUSH-TO-START button. *IN USE* light will come on (indicating start of cycle).

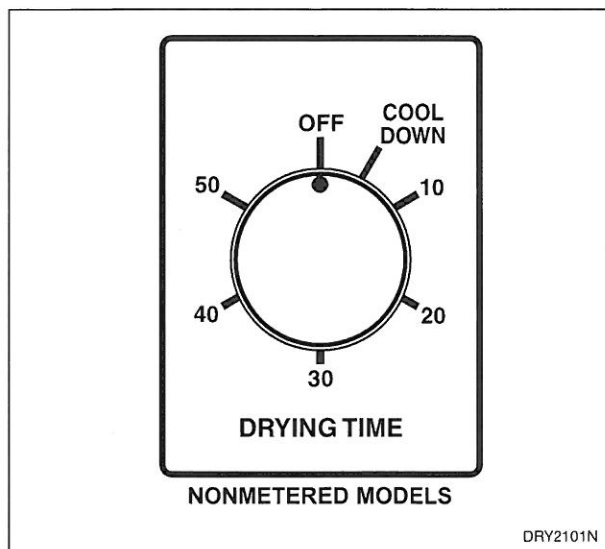

Figure 44

#### Coin Slide Models

Place coin(s) in slide and carefully push in as far as possible and then pull slide out as far as possible. After *IN USE* light comes on (indicating start of cycle), press the PUSH-TO-START button.

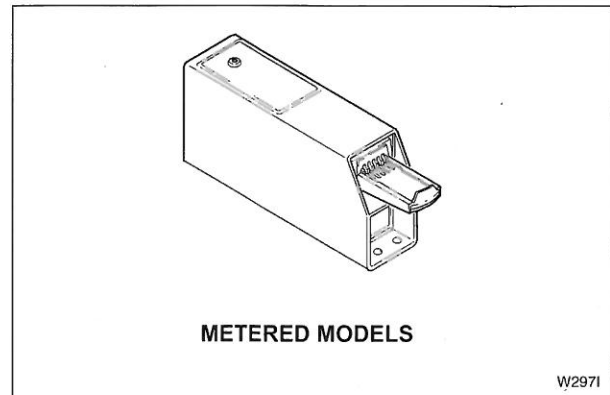

Figure 45

Remove knits when slightly damp because overdrying may cause shrinkage. Do not tumble dry knit woolens.

Should dryer stop before cycle is completed, the motor overload protector may have cycled. Refer to *Maintenance* section.

**NOTE: This machine includes an extended tumble feature. Starting 20 minutes after a cycle ends, the cylinder will tumble for two minutes every hour without heat, up to 18 hours or until door is opened.**

## Operation Instructions for Electronic Display Control Dryers

**IMPORTANT:** Before using dryer for the first time, use an all-purpose cleaner, or a detergent and water solution, and a damp cloth to remove shipping dust from inside of dryer drum.

**IMPORTANT:** Remove all sharp objects from laundry to avoid tears and rips to items during normal machine operation.

### Step 1: Clean Lint Filter

Clean lint filter before each use.

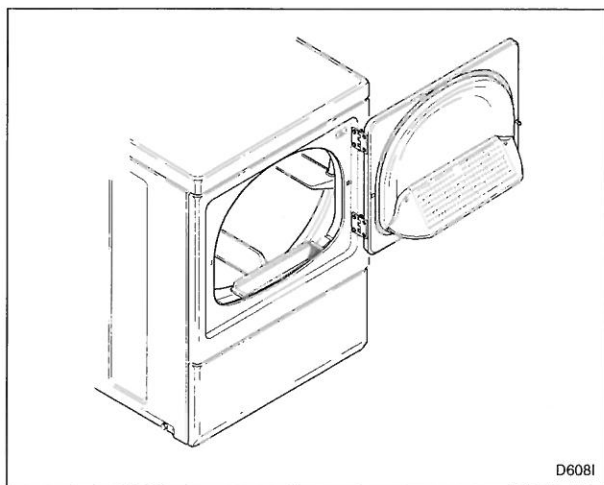

Figure 46

### Step 2: Load Laundry

Load clothes loosely into dryer drum. Add fabric softener sheet if desired.

**IMPORTANT:** To avoid damage to dryer, do not use more than one fabric softener sheet per load.

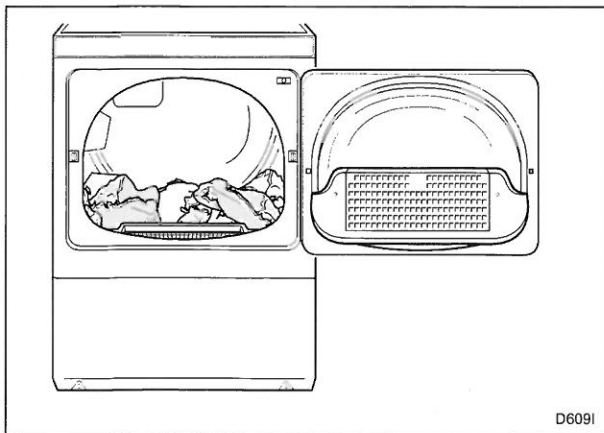

Figure 47

### Step 3: Close Loading Door

Close loading door. Dryer will not operate with the door open.

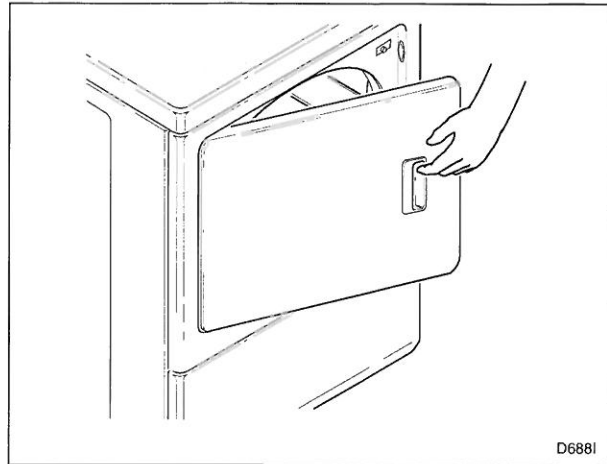

Figure 48

### Step 4: Set Fabric Selector

Select **NORMAL** (High Temp), **PERM PRESS** (Med Temp), **DELICATES** (Low Temp) or **TUMBLE** (No Heat) by pushing touchpad.

**NOTE:** Always follow manufacturer's care label instructions.

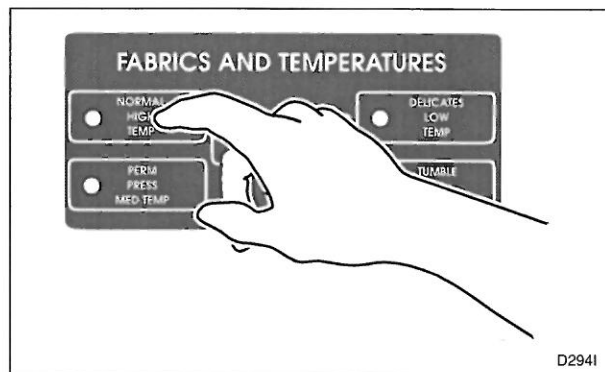

Figure 49

## Operation

### Step 5: Insert Coin(s) or Card

#### To Insert Money

Insert coin(s) in coin slot. Check pricing as seen on digital display.

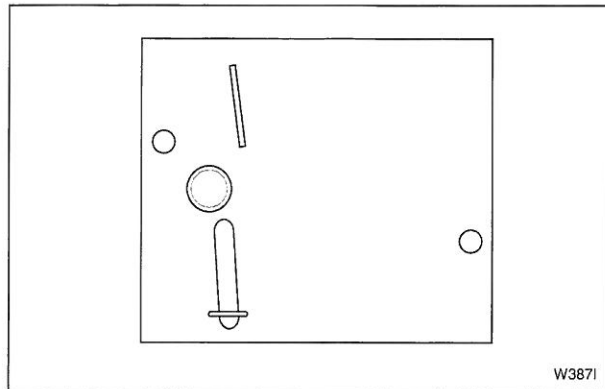

Figure 50

#### To Insert Card

Insert card into opening. Follow directions on display. **DO NOT REMOVE THE CARD UNTIL DISPLAY READS "Remove Card."**

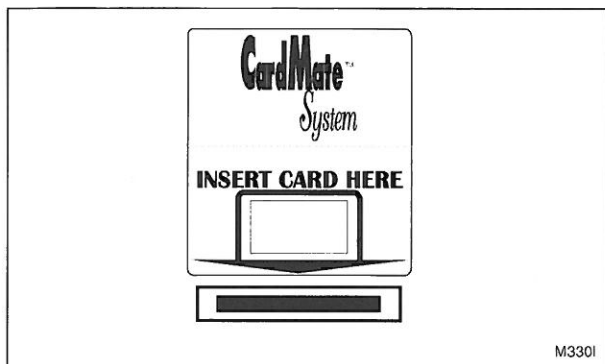

Figure 51

If Additional Time Feature is turned on, additional dryer time may be purchased at cycle start or while dryer is running.

Remove knits when slightly damp because overdrying may cause shrinkage. Do not tumble dry knit woolsens.

### Step 6: Start Dryer

To start dryer, push START pad.

To stop dryer at any time, open the door. To restart the dryer, close door and push START pad.

Cycle is completed when time remaining reaches 00 minutes.

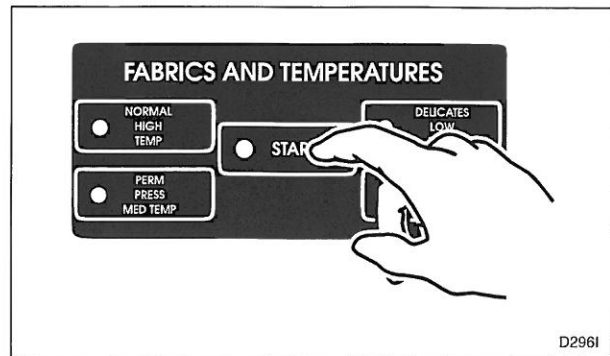

Figure 52

## Indicator Lights

### INSERT COINS

*INSERT COINS* is lit to prompt the user to insert coins or card to satisfy the vend price for the chosen cycle. When *INSERT COINS* is lit, the three digits and decimal point will display the vend price remaining to be satisfied.

### PUSH START

*PUSH START* is lit whenever the dryer is not in a cycle, the full vend price has been satisfied and the dryer door is closed. When the START pad is pressed, the cycle will begin or resume. The *PUSH START* status word flashes at one-second intervals when activated.

**DRYING**

*DRYING* is lit to indicate that one of the heated cycles (HIGH TEMP, MED TEMP, LOW TEMP) is currently in operation. The status word *DRYING* goes off at the end of a heated cycle or when the COOL DOWN cycle begins.

**DOOR OPEN**

*DOOR OPEN* is lit and flashes at one-second intervals whenever the dryer door is open.

**COOL DOWN**

*COOL DOWN* is lit whenever the COOL DOWN portion of a heated cycle is active. It is also lit when the NO HEAT cycle is in operation.

**PRICE**

*PRICE* is lit to indicate that the value displayed is the vend pricing remaining to be satisfied. Once the vend price is satisfied, the word *PRICE* will go off.

**TIME REMAINING**

*TIME REMAINING* is lit to indicate that the time displayed by two digits and the colon is the time remaining (in minutes) in the active cycle. The colon flashes at one-second intervals and time continually counts down in an active cycle.

Should dryer stop before cycle is completed, the motor overload protector may have cycled. Refer to *Maintenance* section.

## Operation

### Operation Instructions for MDC Dryers

**IMPORTANT:** Before using dryer for the first time, use an all-purpose cleaner, or a detergent and water solution, and a damp cloth to remove shipping dust from inside of dryer drum.

**IMPORTANT:** Remove all sharp objects from laundry to avoid tears and rips to items during normal machine operation.

#### Step 1: Clean Lint Filter

Clean lint filter before each use.

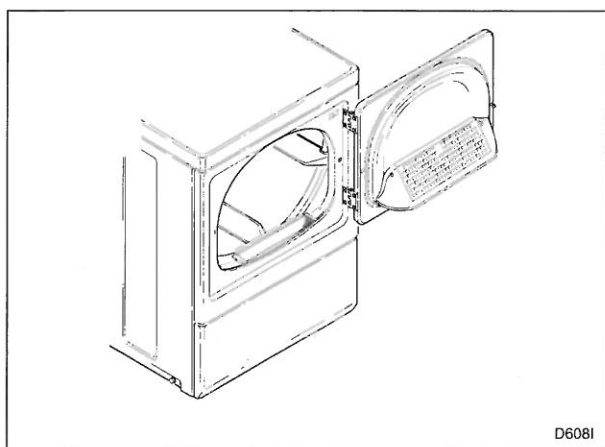

Figure 53

#### Step 2: Load Laundry

Load clothes loosely into dryer drum. Add fabric softener sheet if desired.

**IMPORTANT:** To avoid damage to dryer, do not use more than one fabric softener sheet per load.

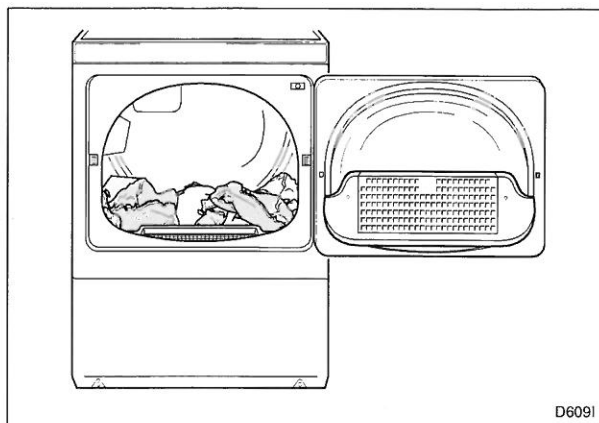

Figure 54

#### Step 3: Close Loading Door

Close loading door. Dryer will not operate with the door open.

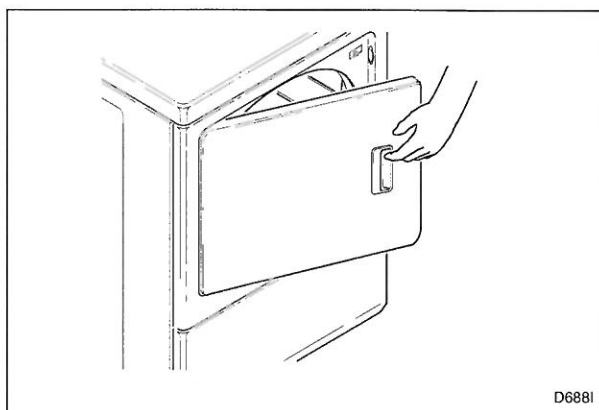

Figure 55

### Step 4: Set Fabric Selector

Select **HIGH TEMP**, **MED TEMP**, **LOW TEMP** or **DELICATES** by pushing touchpad.

**NOTE: Always follow manufacturer's care label instructions.**

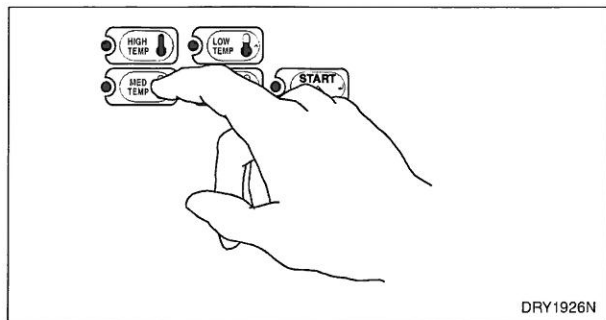

Figure 56

### Step 5: Insert Coin(s) or Card

*To Insert Money*

Insert coin(s) in coin slot. Check pricing as seen on digital display.

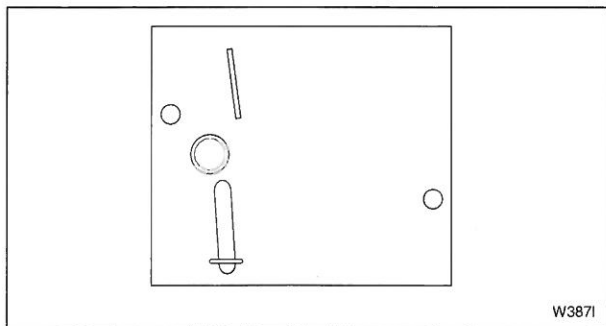

Figure 57

*To Insert Card*

Insert card into opening.

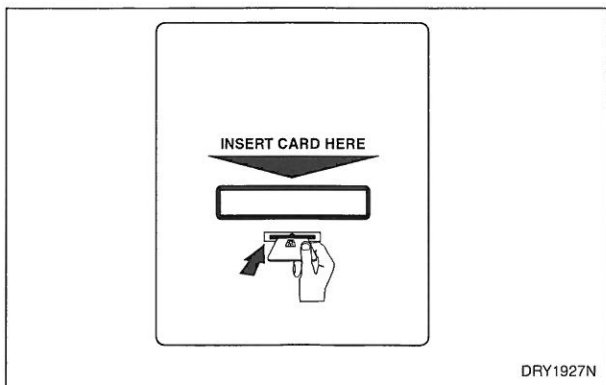

Figure 58

If Additional Time Feature is turned on, additional dryer time may be purchased at cycle start or while dryer is running.

Remove knits when slightly damp because overdrying may cause shrinkage. Do not tumble dry knit woolsens.

### Step 6: Start Dryer

To start dryer, push **START** pad.

To stop dryer at any time, open the door. To restart the dryer, close door and push **START** pad.

Cycle is completed when time remaining reaches 00 minutes.

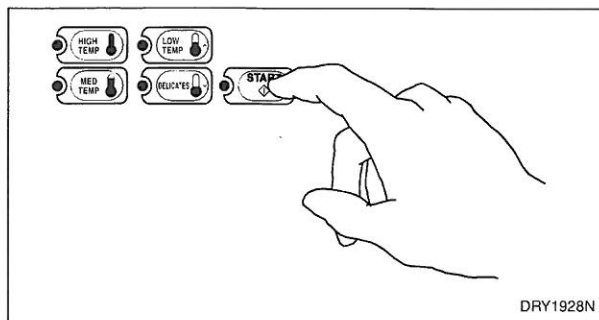

Figure 59

### Indicator Lights

#### START

**START** is lit whenever the dryer is not in a cycle, the full vend price has been satisfied and the dryer door is closed. When the **START** pad is pressed, the cycle will begin or resume.

#### DRYING

**DRYING** is lit to indicate that one of the heated cycles (**HIGH TEMP**, **MED TEMP**, **LOW TEMP** or **DELICATES**) is currently in operation. **DRYING** will turn off at the end of a heated cycle or when the **COOL DOWN** cycle begins.

#### COOL DOWN

**COOL DOWN** is lit whenever the **COOL DOWN** portion of a heated cycle is active. It is also lit when no heat is programmed for a cycle in operation.



## Operation

### Operation Instructions for NetMaster Dryers

**IMPORTANT:** Before using dryer for the first time, use an all-purpose cleaner, or a detergent and water solution, and a damp cloth to remove shipping dust from inside of dryer drum.

**IMPORTANT:** Remove all sharp objects from laundry to avoid tears and rips to items during normal machine operation.

#### Step 1: Clean Lint Filter

Clean lint filter before each use.

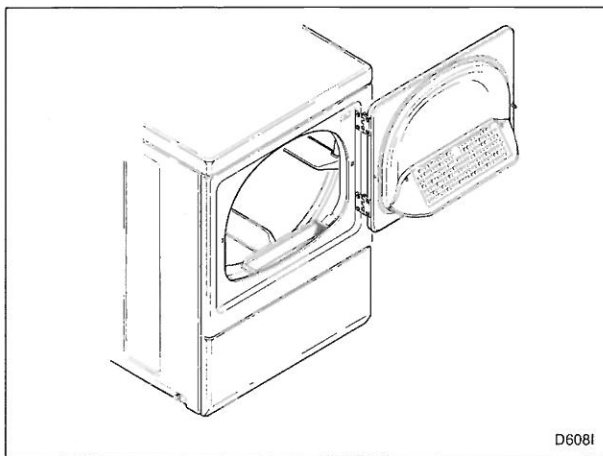

Figure 60

#### Step 2: Load Laundry

Load clothes loosely into dryer drum. Add fabric softener sheet if desired.

**IMPORTANT:** To avoid damage to dryer, do not use more than one fabric softener sheet per load.

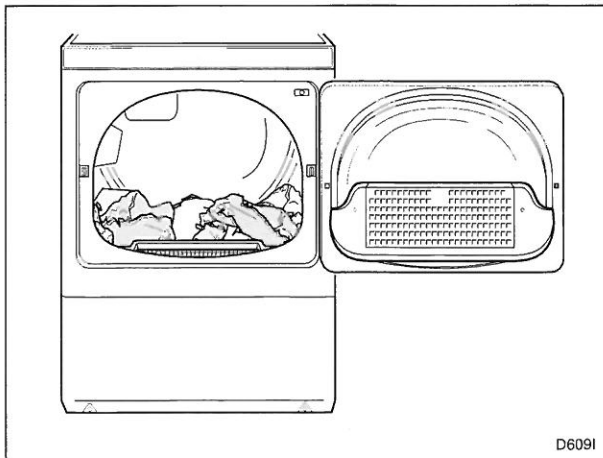

Figure 61

#### Step 3: Close Loading Door

Close loading door. Dryer will not operate with the door open.

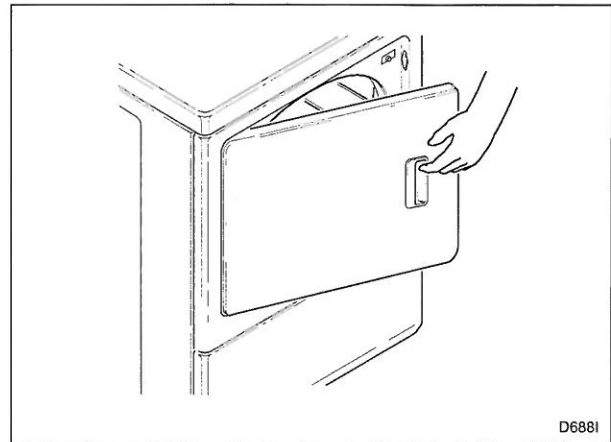

Figure 62

#### Step 4: Set Fabric Selector

Select **HIGH TEMP**, **MED TEMP**, **LOW TEMP** or **NO HEAT** by pushing touchpad.

**NOTE:** Always follow manufacturer's care label instructions.

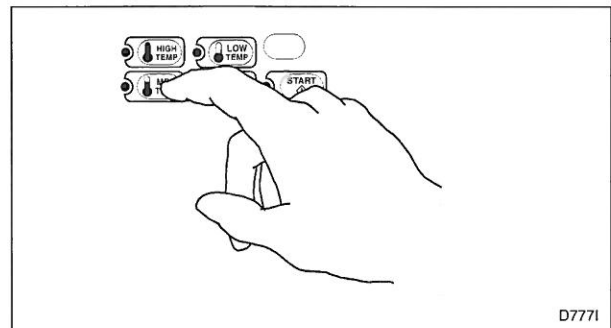

Figure 63

### Step 5: Insert Coin(s) or Card

#### To Insert Money

Insert coin(s) in coin slot. Check pricing as seen on digital display.

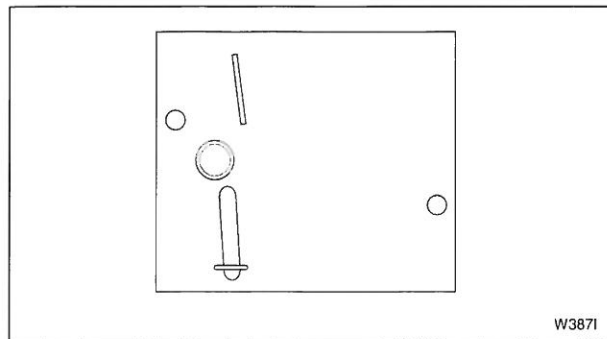

Figure 64

#### To Insert Card

Insert card into opening. Do not remove the card until the *REMOVE CARD* LED is lit.

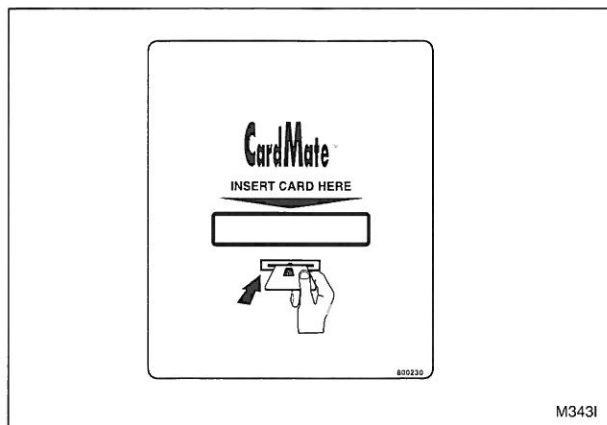

Figure 65

If Additional Time Feature is turned on, additional dryer time may be purchased at cycle start or while dryer is running.

Remove knits when slightly damp because overdrying may cause shrinkage. Do not tumble dry knit woolens.

### Step 6: Start Dryer

To start dryer, push **START** pad.

To stop dryer at any time, open the door. To restart the dryer, close door and push **START** pad.

Cycle is completed when time remaining reaches 00 minutes.

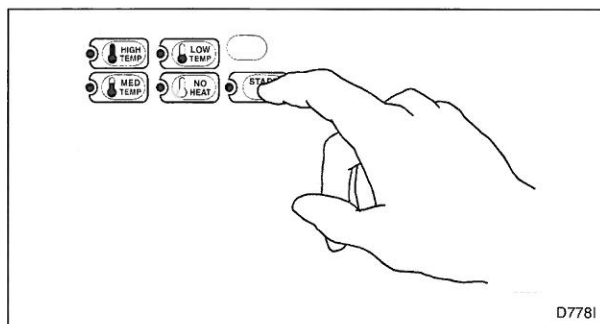

Figure 66

## Operation

### Indicator Lights

#### **INSERT COINS/CARD**

*INSERT COINS/CARD* is lit to prompt the user to insert coins or a card to satisfy the vend price. When *INSERT COINS/CARD* is lit, the three digits and decimal point will display the vend price remaining to be satisfied.

#### **START**

*START* is lit whenever the dryer is not in a cycle, the full vend price has been satisfied and the dryer door is closed. When the **START** pad is pressed, the cycle will begin or resume.

#### **DRYING**

*DRYING* is lit to indicate that one of the heated cycles (HIGH TEMP, MED TEMP, or LOW TEMP) is currently in operation. *DRYING* will turn off at the end of a heated cycle or when the COOL DOWN cycle begins.

#### **COOL DOWN**

*COOL DOWN* is lit whenever the COOL DOWN portion of a heated cycle is active. It is also lit when the NO HEAT cycle is in operation.

#### **ADD TIME (Card Models Only)**

*ADD TIME* flashes when a card is inserted while a cycle is running or when a card is left in the reader for at least five seconds after cycle has started.

#### **REMOVE CARD (Card Models Only)**

*REMOVE CARD* flashes when a card is inserted or left in the reader after a transaction is complete. It will also flash alternately with *ADD TIME* when a card is inserted while a cycle is running or when a card is left in the reader.

# Maintenance

## Lubrication

All moving parts are sealed in a permanent supply of lubricant or are equipped with oilless bearings. Additional lubrication will not be necessary.

## Care of Your Dryer

	<b>WARNING</b>
<b>To reduce the risk of an electric shock, serious injury or death, disconnect the electrical service to the dryer before cleaning the interior.</b>	
W132	

## Dryer Interior

Wipe the surfaces using a soft cloth and household cleaner or a non-abrasive paste of powdered laundry detergent and hot water, followed by a short heat cycle with a load of rags.

To remove crayon or ball point ink off the dryer drum, put the heat on high and use old rags in the dryer to absorb the crayon or ink. If unsuccessful, contact the appliance dealer. **DO NOT** use any chemicals in the dryer.

**IMPORTANT: The use of chlorine bleach for removing any discolorations should be avoided because bleach could damage the finish.**

## Cabinet

Wipe the dryer cabinet as needed. If detergent, bleach or other washing products have been spilled on the dryer, wipe immediately. Some products will cause permanent damage if spilled on the cabinet.

## Control Panel

Use only a damp or sudsy cloth for cleaning the control panel. Some spray pretreat products may harm the finish on the control panel.

**NOTE: The wiring diagram is located inside the control panel.**

	<b>WARNING</b>
<b>Label all wires prior to disconnection when servicing controls. Wiring errors can cause improper and dangerous operation.</b>	
W049	

## Exhaust System

	<b>WARNING</b>
<b>To reduce the risk of electric shock, disconnect the electrical service to the dryer before cleaning.</b>	
W043	

The exhaust duct should be inspected after one year of use and cleaned if necessary by a qualified service person to remove any lint build-up. Inspect and clean exhaust duct every one to two years as required thereafter.

The weather hood should be checked frequently to make sure the dampers move freely, dampers are not pushed in and that nothing has been set against them.

Keep dryer area clear and free from combustible materials, gasoline and other flammable vapors and liquids.

Do not obstruct the flow of combustion and ventilation air.

**NOTE: Verify proper operation after servicing.**

## Maintenance

### Lint Filter

CLEAN THE LINT FILTER BEFORE DRYING EACH LOAD. (Refer to *Figure 67* for lint filter location.) Cleaning the lint filter is important because a layer or pad of lint on the filter will block the flow of air through the dryer, thus reducing the efficiency of the dryer. The clothes will take longer to dry and energy will be wasted.

The lint filter may be washed if needed. Annually remove lint filter and screw to vacuum the duct under it.

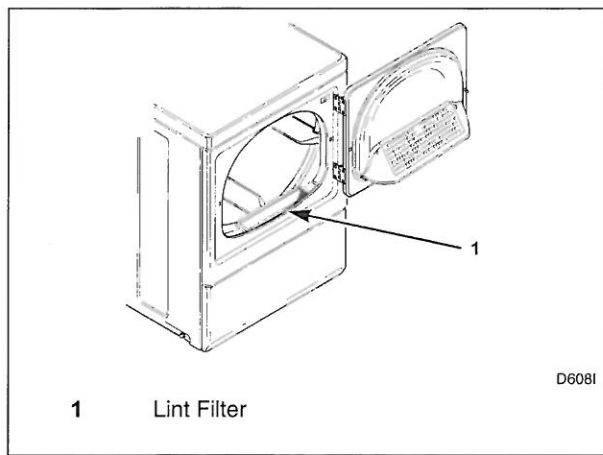

Figure 67

### Motor Overload Protector

The dryer's motor overload protector stops the motor automatically in the event of an overload. After cooling, the overload protector will reset itself. Dryer can be restarted by pressing the PUSH-TO-START button or START pad. If overload protector cycles again, remove the dryer from use and call the service person to correct the problem.

### For Energy Conservation

- Make sure the lint filter is always clean.
- Do not overload dryer.
- Do not overdry clothes.
- Remove items to be ironed while still damp.
- Large loads of similar fabrics dry the most efficiently. However, dry permanent press in smaller loads to prevent wrinkling.
- Use the correct temperature FABRIC SELECTOR setting for the type of fabric being dried.
- Locate your dryer so the exhaust duct is as short and straight as possible.
- Do not open the door during the drying cycle.
- Plan to do your laundry on low humidity days; your clothes will dry faster.
- Should you plan to dry several loads, do them one after another, then you do not have to reheat the dryer unit's interior parts each time.

# Troubleshooting

Try these troubleshooting tips before making a service call. They may save you time and money.

Dryer Symptom	Possible Cause/Solution
<b>Dryer won't start</b>	<ul style="list-style-type: none"> <li>• Nonmetered models - Turn timer knob further into cycle.</li> <li>• Metered models - Insert coin(s) or card.</li> <li>• Metered models - Activate timer. Push coin slide all the way in.</li> <li>• For dryers equipped with a power cord, make sure the power cord is plugged all the way into the electrical outlet.</li> <li>• Make sure loading door is closed.</li> <li>• Press PUSH-TO-START button or START pad.</li> <li>• Make sure the laundry room fuse(s) isn't blown or loose, or circuit breakers aren't open. The dryer itself does not have an electrical fuse. An electric dryer has an electrical circuit with two fuses.</li> <li>• Check if motor overload protector has cycled. Wait 10 minutes and try again.</li> </ul>
<b>Dryer won't heat</b>	<ul style="list-style-type: none"> <li>• Nonmetered models - Turn timer knob further into cycle.</li> <li>• Metered models - Activate timer. Push coin slide all the way in.</li> <li>• Make sure the laundry room fuse(s) isn't blown or loose, or circuit breakers aren't open. The dryer itself does not have an electrical fuse. An electric dryer has an electrical circuit with two fuses.</li> <li>• Make sure controls are in a HEAT setting.</li> <li>• Gas dryer only – Make sure equipment and main gas line valve is turned on.</li> <li>• Check exhaust duct to outside to see if it is kinked, blocked or needs cleaning.</li> <li>• Check weather hood to make sure flapper moves freely, has not been pushed in or has not been blocked.</li> </ul>
<b>Dryer doesn't dry clothes satisfactorily</b>	<ul style="list-style-type: none"> <li>• Check exhaust duct to outside to see if it is kinked, blocked or needs cleaning.</li> <li>• Check weather hood to make sure flapper moves freely, has not been pushed in or has not been blocked.</li> <li>• Clean the lint filter.</li> <li>• Make sure the load isn't too small. Small loads may not tumble properly or dry evenly.</li> <li>• Check load being dried. Heavy items dried with lightweight items will not dry as quickly as the rest of the load.</li> </ul>
<b>Dryer is noisy</b>	<ul style="list-style-type: none"> <li>• Check dryer for foreign objects (nails, coins, bobby pins, metal, plastic toys, etc.). Remove items from dryer.</li> <li>• Make sure dryer is level. Uneven leveling can cause vibration.</li> <li>• Normal operating sounds include the tick of timer advancing, heat source going on and off, and humming of air moving through the dryer and exhaust system.</li> </ul>
<b>Clothes are too wrinkled</b>	<ul style="list-style-type: none"> <li>• Check heat setting. Overdrying can cause wrinkling.</li> <li>• Check load size. Large loads may not tumble properly and may cause wrinkling.</li> </ul>
<b>Clothes have odor</b>	<ul style="list-style-type: none"> <li>• Check room for odors before drying clothes. Any odor (fried foods, paint, varnish, cleaners, burning wood, etc.) will transfer to clothing as the dryer draws air from the room. Ventilate room before drying clothes.</li> </ul>

# Contact Information

If service is required, contact the nearest Factory Authorized Service Center.

If you are unable to locate an authorized service center or are unsatisfied with the service performed on your dryer, contact:

**Alliance Laundry Systems**  
Shepard Street  
P. O. Box 990  
Ripon, WI 54971-0990  
U.S.A.  
[www.comlaundry.com](http://www.comlaundry.com)  
Phone: (920) 748-3121

Date Purchased \_\_\_\_\_

Model Number \_\_\_\_\_

Serial Number \_\_\_\_\_

When calling or writing about your dryer, **PLEASE GIVE THE MODEL AND SERIAL NUMBERS.** The model and serial numbers are located on the nameplate. The nameplate will be in the location shown in the illustration below. Please include a copy of your bill of sale and any service receipts you have.

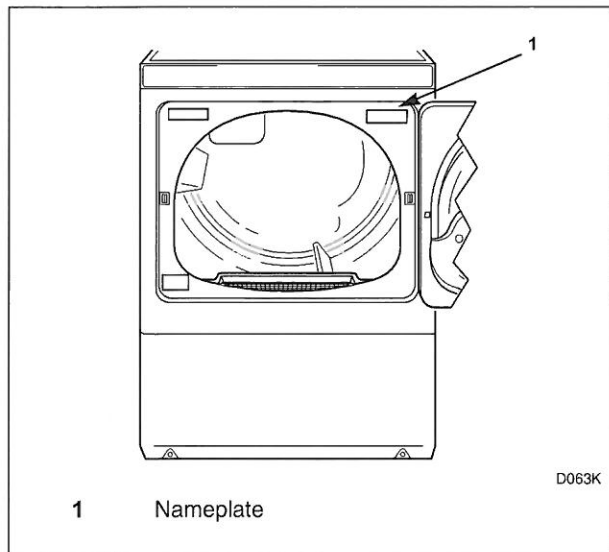

Figure 68

	<b>WARNING</b>
<p><b>To reduce the risk of serious injury or death, DO NOT repair or replace any part of the dryer or attempt any servicing unless specifically recommended in the user-maintenance instructions or in published user-repair instructions that you understand and have the skills to carry out.</b></p>	
<small>W133</small>	

If replacement parts are required, contact the source from which you purchased your dryer or contact us at (920) 748-3950 for the name and address of the nearest authorized parts distributor.

# Installer Checklist

## Fast Track for Installing the Dryer

(Refer to the manual for more detailed information)

**1** • Position and Level the Dryer.

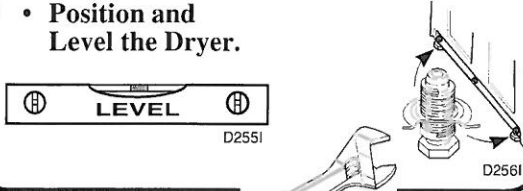

A diagram showing a level (D2551) being used to check the dryer's level. A wrench (D2591) is shown adjusting the leveling legs (D2561).

CHECK

**6** • Wipe Out Inside of Dryer.

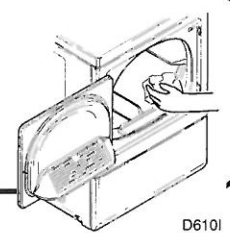

A diagram showing a hand wiping the interior of the dryer drum (D610).

CHECK

**2** • Connect Dryer Exhaust System.

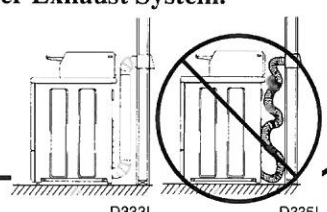

A diagram showing the dryer (D3331) connected to an exhaust duct (D3351). A red 'X' is placed over a section of the duct to indicate it should not be used.

CHECK

**7** • Plug In the Dryer.

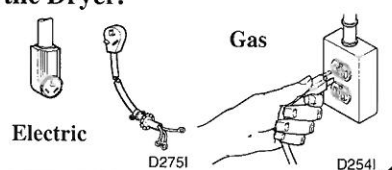

A diagram showing the dryer being plugged into either an electric outlet (D2751) or a gas outlet (D2541).

CHECK

**3** **GAS ONLY**

- Connect Gas Supply Pipe Hoses.
- Check for Gas Leaks.

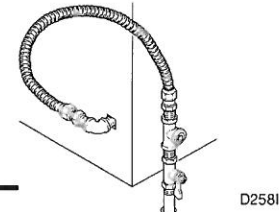

A diagram showing a gas supply pipe (D2581) being connected to the dryer.

CHECK

**8** • Recheck Steps 1-7.

CHECK

**4** **ELECTRIC ONLY**

- Connect Electrical Cord.

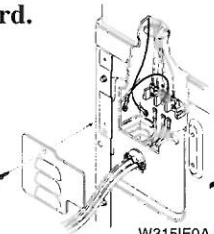

A diagram showing an electrical cord being connected to the dryer (W3151E0A).

CHECK

**9** • Check Heat Source.

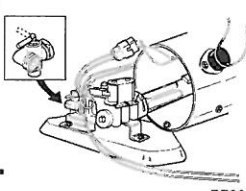

A diagram showing the dryer's heat source being checked (D7001).

CHECK

**5** • Reverse Door, if Desired.

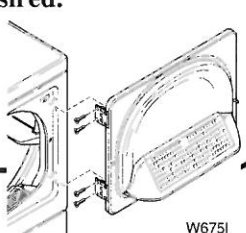

A diagram showing the dryer door (W6751) being reversed.

CHECK



# Clothes Dryer

Nonmetered and Metered  
Electric and Gas Models

— Installation/Operation —

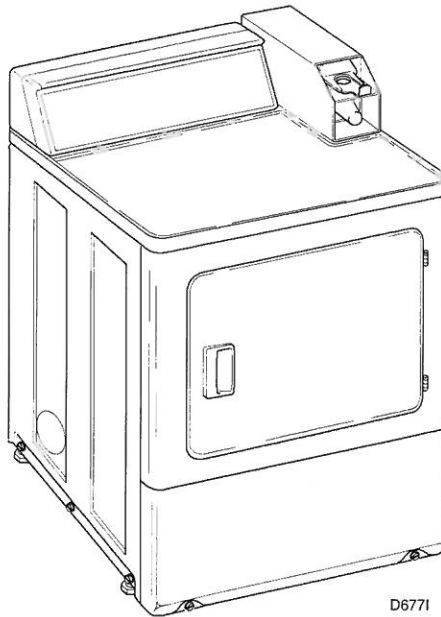

D6771

Para bajar una copia de estas instrucciones en español, visite [www.comlaundry.com](http://www.comlaundry.com).

**Keep These Instructions for Future Reference.**

(If this machine changes ownership, this manual must accompany machine.)



[www.comlaundry.com](http://www.comlaundry.com)

Part No. 512680R2  
July 2007



## WARNING

**FOR YOUR SAFETY**, the information in this manual must be followed to minimize the risk of fire or explosion or to prevent property damage, personal injury or death.

W033

- Do not store or use gasoline or other flammable vapors and liquids in the vicinity of this or any other appliance.
- **WHAT TO DO IF YOU SMELL GAS:**
  - Do not try to light any appliance.
  - Do not touch any electrical switch; do not use any phone in your building.
  - Clear the room, building or area of all occupants.
  - Immediately call your gas supplier from a neighbor's phone. Follow the gas supplier's instructions.
  - If you cannot reach your gas supplier, call the fire department.
- Installation and service must be performed by a qualified installer, service agency or the gas supplier.

W052

**IMPORTANT:** Purchaser must consult the local gas supplier for suggested instructions to be followed if the dryer user smells gas. The gas utility instructions plus the **SAFETY** and **WARNING** note directly above must be posted in a prominent location near the dryer for customer use.

## FOR YOUR SAFETY

**Do not store or use gasoline or other flammable vapors and liquids in the vicinity of this or any other appliance.**

W053

The following information applies to the state of Massachusetts, USA.

- This appliance can only be installed by a Massachusetts licensed plumber or gas fitter.
- This appliance must be installed with a 36 inch (91 cm) long flexible gas connector.
- A "T-Handle" type gas shut-off valve must be installed in the gas supply line to this appliance.
- This appliance must not be installed in a bedroom or bathroom.

# Table of Contents

<b>Safety Information</b> .....	4
Explanation of Safety Messages.....	4
Important Safety Instructions .....	4
<b>Installation</b> .....	6
Dimensions .....	6
Nonmetered Models.....	6
Metered Models .....	7
Before You Start.....	8
Tools .....	8
Card Reader Models .....	8
Installing the Dryer.....	9
Step 1: Position and Level the Dryer .....	9
Step 2: Connect Dryer Exhaust System .....	11
Exhaust Direction.....	12
Exhaust System.....	13
Multi-Dryer Installation Exhaust Requirements.....	14
Step 3: (Gas Dryer Only) Connect Gas Supply Pipe .....	16
Step 4: (Electric Dryer Only) Connect Electrical Plug.....	17
Step 5: Reverse Door, if Desired .....	23
Step 6: Wipe Out Inside of Dryer .....	24
Step 7: Plug In the Dryer .....	24
Step 8: Recheck Steps 1-7.....	26
Step 9: Check Heat Source .....	26
<b>Vending</b> .....	27
Meter Case .....	27
Coin Slide Control .....	27
Power-Up Mode.....	27
Ready Mode .....	27
Start Mode.....	27
Run Mode.....	27
Door Open Mode .....	27
End of Cycle Mode .....	27
Topoffs .....	27
Temperature Selector Switch.....	27
Error Display Mode .....	28
Setting Dry Time Dipswitches.....	28
Dipswitch Settings .....	29
Test Setting .....	31
Slide Extension .....	32
Additional Dryer Security.....	34

© Copyright 2007, Alliance Laundry Systems LLC

All rights reserved. No part of the contents of this book may be reproduced or transmitted in any form or by any means without the expressed written consent of the publisher.

<b>Operation</b> .....	35
Operation Instructions for Nonmetered and Coin Slide Dryers .....	35
Step 1: Clean Lint Filter.....	35
Step 2: Load Laundry.....	35
Step 3: Close Loading Door.....	35
Step 4: Set Fabric Selector.....	36
Step 5: Start Dryer .....	36
Operation Instructions for Electronic Display Control Dryers.....	37
Step 1: Clean Lint Filter.....	37
Step 2: Load Laundry.....	37
Step 3: Close Loading Door.....	37
Step 4: Set Fabric Selector.....	37
Step 5: Insert Coin(s) or Card .....	38
Step 6: Start Dryer .....	38
Indicator Lights .....	38
Operation Instructions for MDC Dryers.....	40
Step 1: Clean Lint Filter.....	40
Step 2: Load Laundry.....	40
Step 3: Close Loading Door.....	40
Step 4: Set Fabric Selector.....	41
Step 5: Insert Coin(s) or Card .....	41
Step 6: Start Dryer .....	41
Indicator Lights.....	41
Operation Instructions for NetMaster Dryers .....	42
Step 1: Clean Lint Filter.....	42
Step 2: Load Laundry.....	42
Step 3: Close Loading Door.....	42
Step 4: Set Fabric Selector.....	42
Step 5: Insert Coin(s) or Card .....	43
Step 6: Start Dryer .....	43
Indicator Lights.....	44
<b>Maintenance</b> .....	45
Lubrication.....	45
Care of Your Dryer .....	45
Dryer Interior .....	45
Cabinet .....	45
Control Panel .....	45
Exhaust System.....	45
Lint Filter .....	46
Motor Overload Protector.....	46
For Energy Conservation.....	46
<b>Troubleshooting</b> .....	47
<b>Contact Information</b> .....	48
<b>Installer Checklist</b> .....	Back Cover

# Safety Information

## Explanation of Safety Messages

Throughout this manual and on machine decals, you will find precautionary statements (“DANGER,” “WARNING,” and “CAUTION”) followed by specific instructions. These precautions are intended for the personal safety of the operator, user, servicer, and those maintaining the machine.

	<b>DANGER</b>
<b>Indicates an imminently hazardous situation that, if not avoided, will cause severe personal injury or death.</b>	

	<b>WARNING</b>
<b>Indicates a hazardous situation that, if not avoided, could cause severe personal injury or death.</b>	

	<b>CAUTION</b>
<b>Indicates a hazardous situation that, if not avoided, may cause minor or moderate personal injury or property damage.</b>	

Additional precautionary statements (“IMPORTANT” and “NOTE”) are followed by specific instructions.

**IMPORTANT:** The word “IMPORTANT” is used to inform the reader of specific procedures where minor machine damage will occur if the procedure is not followed.

**NOTE:** The word “NOTE” is used to communicate installation, operation, maintenance or servicing information that is important but not hazard related.

## Important Safety Instructions

### Save These Instructions

	<b>WARNING</b>
<b>To reduce the risk of fire, electric shock, or injury to persons when using your dryer, follow these basic precautions:</b>	
<small>W034</small>	

1. Read all instructions before using the dryer.
2. Refer to the GROUNDING INSTRUCTIONS in the INSTALLATION manual for the proper grounding of the dryer.
3. Do not dry articles that have been previously cleaned in, washed in, soaked in, or spotted with gasoline, dry-cleaning solvents, other flammable or explosive substances as they give off vapors that could ignite or explode.
4. Do not allow children to play on or in the dryer. Close supervision of children is necessary when the dryer is used near children. This is a safety rule for all appliances.
5. Before the dryer is removed from service or discarded, remove the door to the drying compartment.
6. Do not reach into the dryer if the cylinder is revolving.
7. Do not install or store the dryer where it will be exposed to water and/or weather.
8. Do not tamper with the controls.
9. Do not repair or replace any part of the dryer, or attempt any servicing unless specifically recommended in the user-maintenance instructions or in published user-repair instructions that you understand and have the skills to carry out.
10. Do not use fabric softeners or products to eliminate static unless recommended by the manufacturer of the fabric softener or product.
11. To reduce the risk of fire, DO NOT DRY plastics or articles containing foam rubber or similarly textured rubberlike materials.
12. ALWAYS clean the lint filter after every load. A layer of lint in the filter reduces drying efficiency and prolongs drying time.

13. Keep area around the exhaust opening and adjacent surrounding area free from the accumulation of lint, dust and dirt.
14. The interior of the dryer and the exhaust duct should be cleaned periodically by qualified service personnel.
15. If not installed, operated and maintained in accordance with the manufacturer's instructions or if there is damage to or mishandling of this product's components, use of this product could expose you to substances in the fuel or from fuel combustion which can cause death or serious illness and which are known to the State of California to cause cancer, birth defects or other reproductive harm.
16. Dryer will not operate with the loading door open. DO NOT bypass the door safety switch by permitting the dryer to operate with the door open. The dryer will stop tumbling when the door is opened. Do not use the dryer if it does not stop tumbling when the door is opened or starts tumbling without pressing the START mechanism. Remove the dryer from use and call the service person.
17. Do not put articles soiled with vegetable or cooking oil in the dryer, as these oils may not be removed during washing. Due to the remaining oil, the fabric may catch on fire by itself.
18. To reduce the risk of fire, DO NOT put clothes which have traces of any flammable substances such as machine oil, flammable chemicals, thinner, etc., or anything containing wax or chemicals such as in mops and cleaning cloths, or anything dry-cleaned at home with a dry-cleaning solvent in the dryer.
19. Use the dryer only for its intended purpose, drying clothes.
20. Always disconnect the electrical power to the dryer before attempting service. Disconnect the power cord by grasping the plug, not the cord.
21. If supply cord is damaged, it must be replaced by a special cord or assembly available from the manufacturer or its service agent.
22. Install this dryer according to the INSTALLATION INSTRUCTIONS. All connections for electrical power, grounding and gas supply must comply with local codes and be made by licensed personnel when required. Do not do it yourself unless you know how!
23. Remove laundry immediately after the dryer stops.
24. Always read and follow manufacturer's instructions on packages of laundry and cleaning aids. Heed all warnings or precautions. To reduce the risk of poisoning or chemical burns, keep them out of reach of children at all times (preferably in a locked cabinet).
25. Do not tumble fiberglass curtains and draperies unless the label says it can be done. If they are dried, wipe out the cylinder with a damp cloth to remove particles of fiberglass.
26. ALWAYS follow the fabric care instructions supplied by the garment manufacturer.
27. Never operate the dryer with any guards and/or panels removed.
28. DO NOT operate the dryer with missing or broken parts.
29. DO NOT bypass any safety devices.
30. Failure to install, maintain, and/or operate this machine according to the manufacturer's instructions may result in conditions which can produce bodily injury and/or property damage.

**IMPORTANT: Solvent vapors from dry-cleaning machines create acids when drawn through the heater of the drying unit. These acids are corrosive to the dryer as well as to the laundry load being dried. Be sure make-up air is free of solvent vapors.**

**IMPORTANT: Have your dryer installed properly. Don't do it yourself unless you know how!**

**NOTE: The WARNING and IMPORTANT SAFETY INSTRUCTIONS appearing in this manual are not meant to cover all possible conditions and situations that may occur. Common sense, caution and care must be exercised when installing, maintaining, or operating the dryer.**

Always contact your dealer, distributor, service agent or the manufacturer about any problems or conditions you do not understand.

# Installation

## Dimensions

### Nonmetered Models

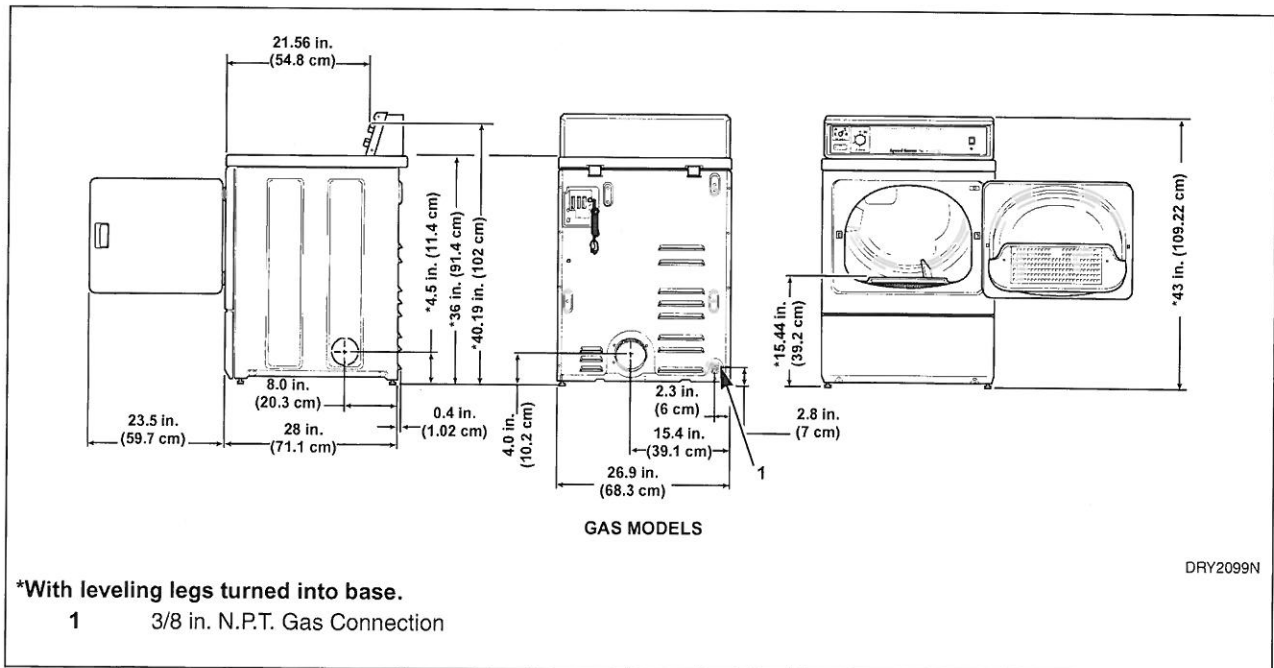
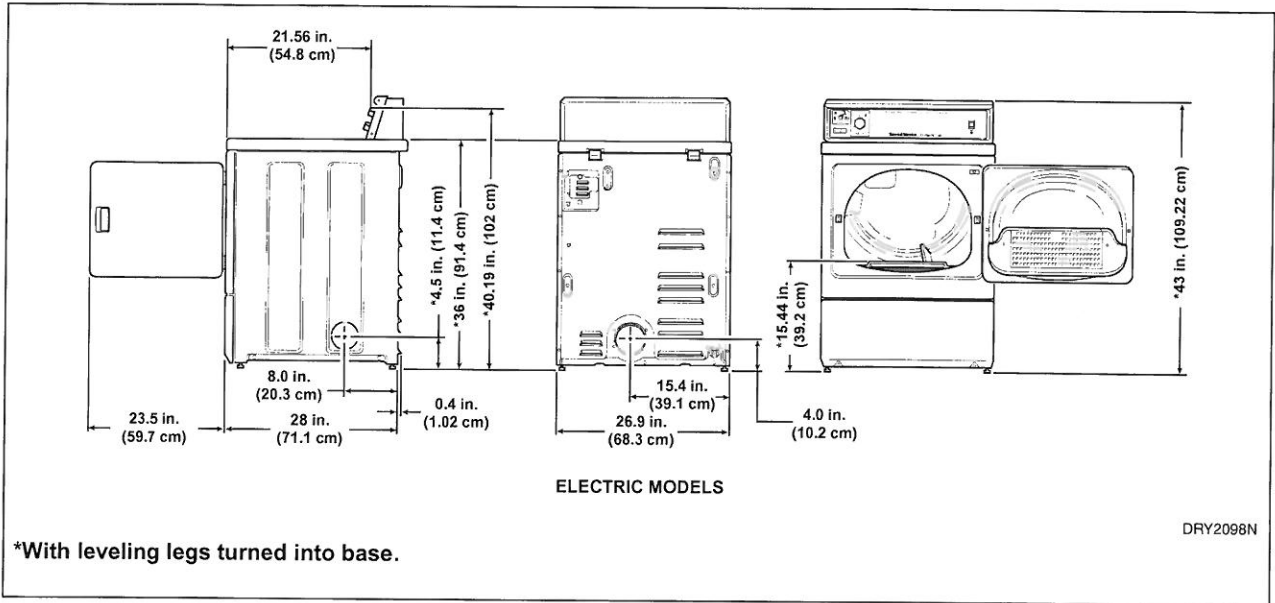

Metered Models

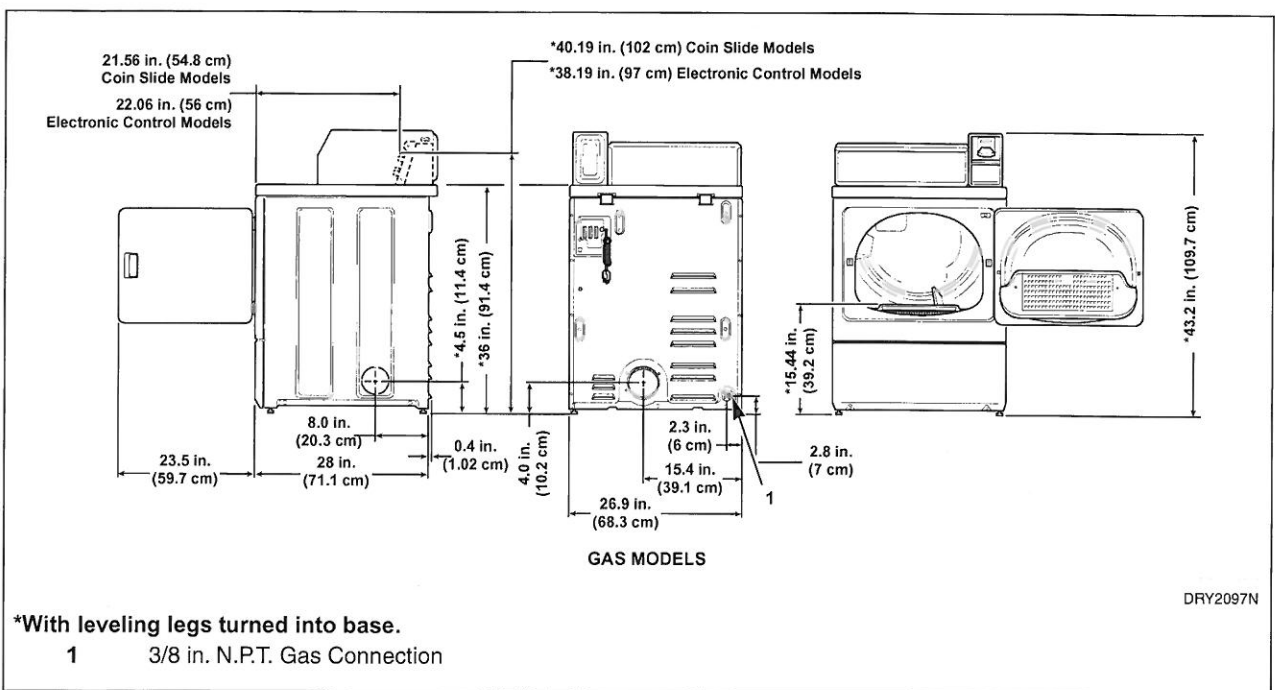
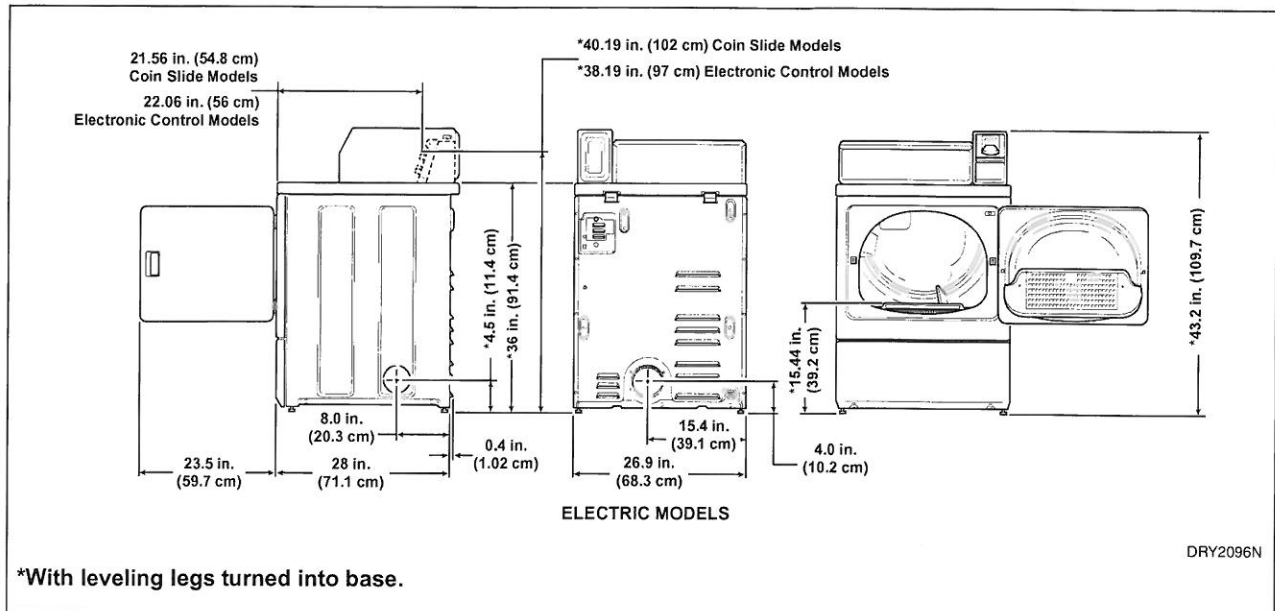

**NOTE:** Side, rear and bottom exhaust openings are 4 inch (10.2 cm) ducting. Gas models cannot be vented out left side of cabinet because of burner housing.

**IMPORTANT:** The dryer should have sufficient clearance around it for needed ventilation and for the ease of installation and servicing. For maximum drying performance, we recommend that more clearance be allowed around the dryer than the clearances that are listed throughout this manual.



## Installation

### Before You Start

#### Tools

For most installations, the basic tools you will need are:

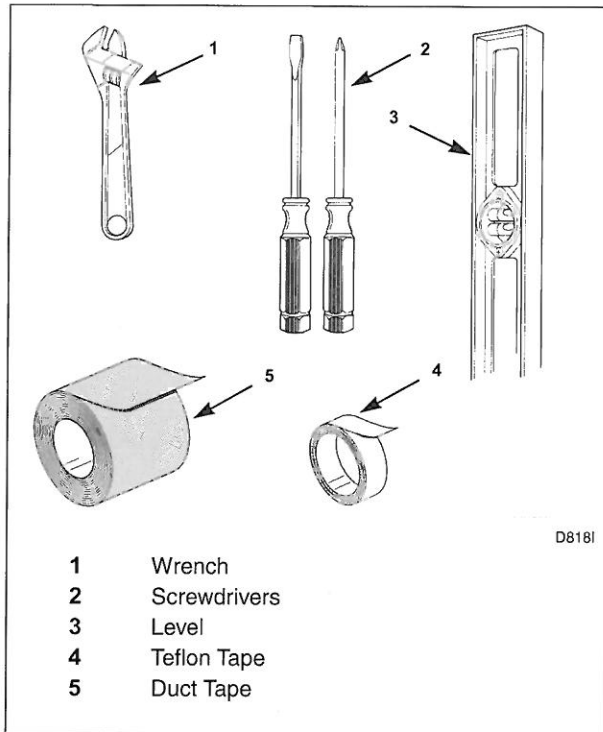

Figure 1

**NOTE:** An 8 in. (20.32 cm) coin drawer is required for coin operated MDC and NetMaster models.

#### Card Reader Models

The machine is shipped from the factory with the Electronic Control Diagnostic Harness Assembly unplugged. To avoid unauthorized manual programming or vending perform the following steps.

1. Open service door. Refer to *Figure 1*.
2. Locate diagnostic harness on electronic control.
3. Plug connectors for “white/black” wire and “red/blue” wire together.

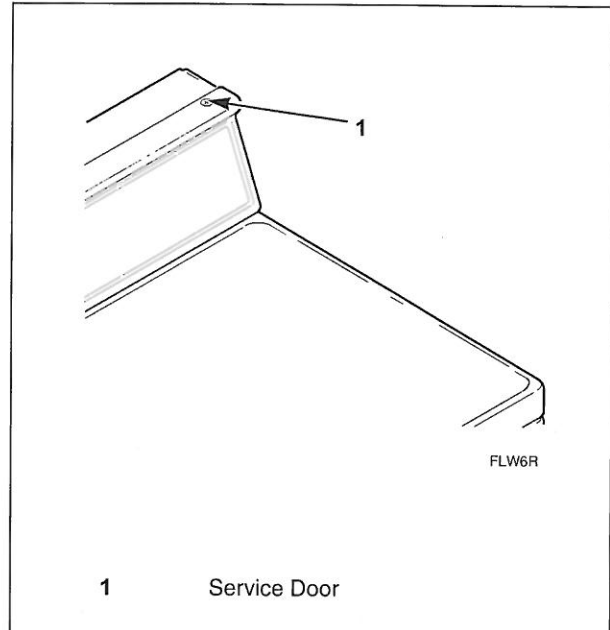

Figure 2



### WARNING

Any disassembly requiring the use of tools must be performed by a suitably qualified service person.

W299

## Installing the Dryer

### Step 1: Position and Level the Dryer

Install dryer before washer. This allows room for attaching exhaust duct.

Install the four rubber feet (in accessories bag).

Select a location with a solid floor. Dryers installed in residential garages must be elevated 18 inches (46 cm) above the floor.

No other fuel burning appliance should be installed in the same closet with the dryer.

The dryer must not be installed or stored in an area where it will be exposed to water and/or weather.

The dryer needs sufficient clearance and an adequate air supply for proper operation and ventilation, and for easier installation and servicing. (Minimum clearances are shown in *Figure 4*).

Place the dryer in position, and adjust the legs until the dryer is level from side to side and front to back. Leveling legs can be adjusted from inside the dryer with a 1/4 in. driver. All four legs must rest firmly on the floor so the weight of the dryer is evenly distributed. The dryer must not rock.

**IMPORTANT:** In mobile home installations, gas dryers **MUST** be permanently attached to the floor at the time of installation. Order No. 526P3 Hold Down Kit (available at extra cost) for a manufactured (mobile) home installation. Follow the instructions supplied with the kit.

Installation of unit must conform to the Manufactured Home Construction and Safety Standards, Title 24 CF4, Part 32-80 or Standard CAN/CSA-Z240 MH.

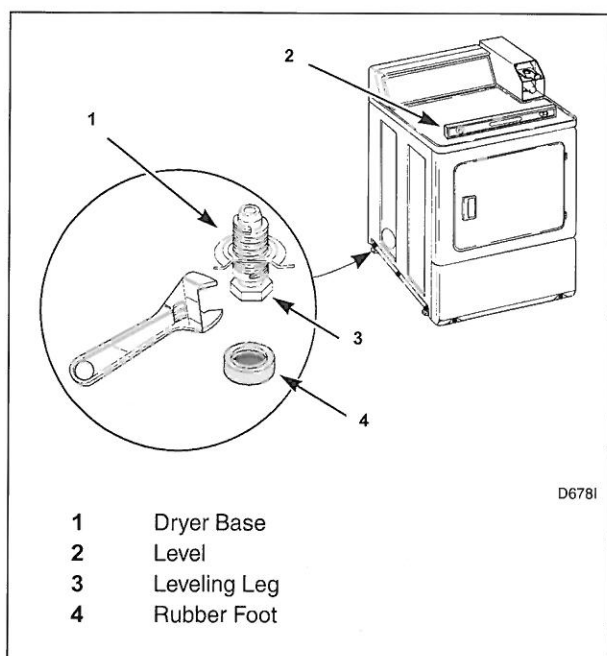

Figure 3

# Installation

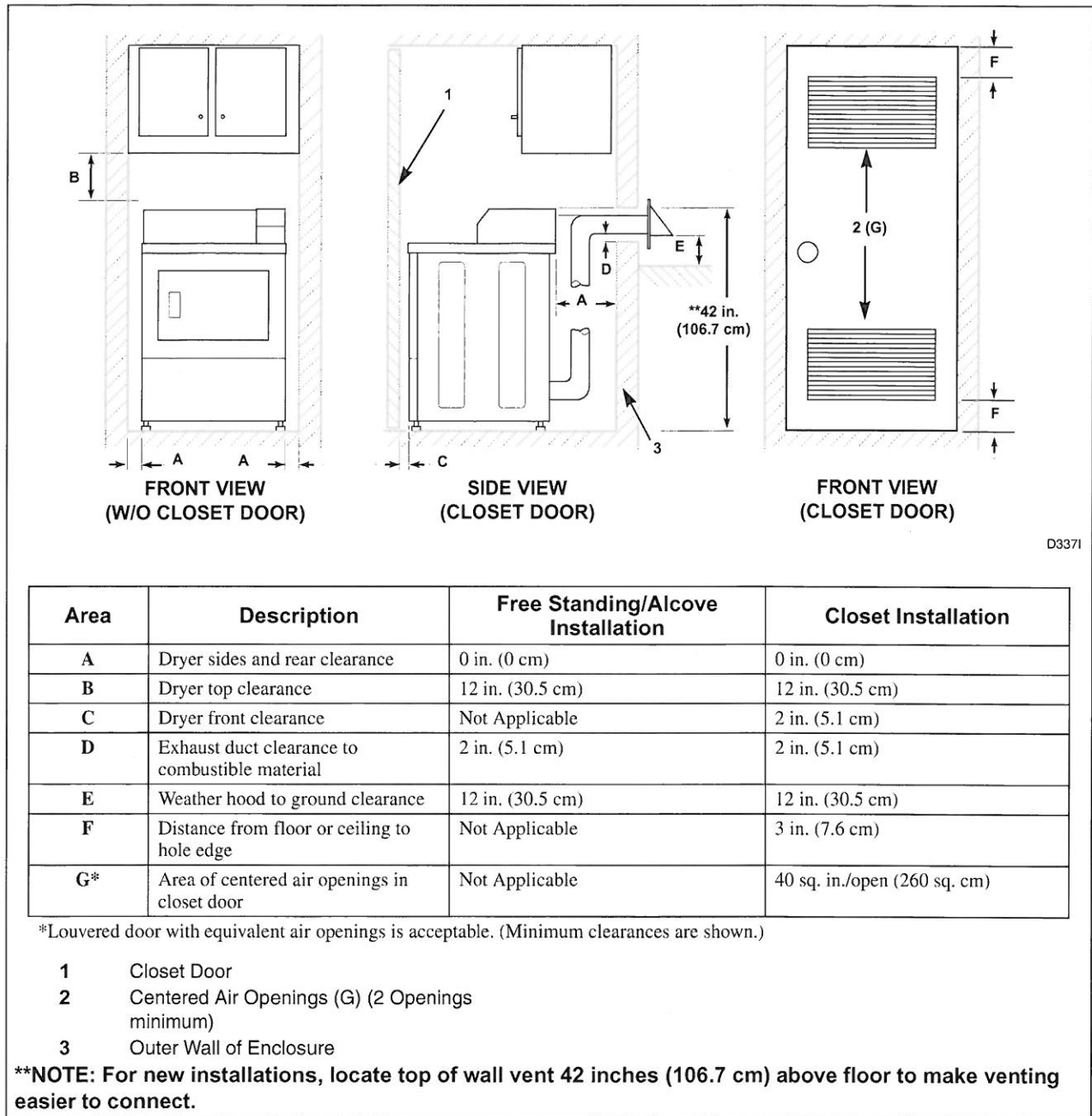

Figure 4

Step 2: Connect Dryer Exhaust System

**WARNING**

To reduce the risk of fire and combustion gas accumulation the dryer **MUST** be exhausted to the outdoors.

W604

To reduce the risk of fire and the accumulation of combustion gases, **DO NOT** exhaust dryer air into a window well, gas vent, chimney or enclosed, unventilated area, such as an attic, wall, ceiling, crawl space under a building or concealed space of a building.

W045

**WARNING**

This gas appliance contains or produces a chemical or chemicals which can cause death or serious illness and which are known to the State of California to cause cancer, birth defects, or other reproductive harm. To reduce the risk from substances in the fuel or from fuel combustion, make sure this appliance is installed, operated, and maintained according to the instructions in this manual.

W115

To reduce the risk of fire, **DO NOT** use plastic or thin foil ducting to exhaust the dryer.

W354

To reduce the risk of fire, the exhaust duct and weather hood **MUST** be fabricated of a material that will not support combustion. Rigid or flexible metal pipe is recommended for a clothes dryer.

W048

- **DO NOT** use plastic or thin foil ducting. Rigid metal duct is recommended.

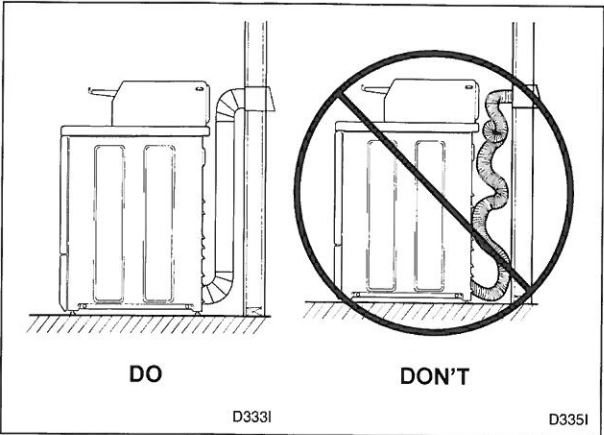

Figure 5

- Locate dryer so exhaust duct is as short as possible.
- Be certain old ducts are cleaned before installing your new dryer.
- Use 4 inch (102 mm) diameter rigid or flexible metal duct.
- The male end of each section of duct must point away from the dryer.
- Use as few elbows as possible.
- Use duct tape or pop-rivets on all duct joints. **DO NOT** use sheet metal screws or fasteners on exhaust pipe joints which extend into the duct.
- Ductwork that runs through unheated areas must be insulated to help reduce condensation and lint build-up on pipe walls.
- Install backdraft dampers in multi-dryer installations.
- In mobile home installations, dryer exhaust duct must be secured to mobile home structure.
- Dryer exhaust duct **MUST NOT** terminate under mobile home.
- Dryer exhausts 220 cfm (measured at back of dryer).
- **DO NOT** install flexible duct in concealed spaces, such as a wall or ceiling.

## Installation

- Static pressure in exhaust duct should not be greater than .6 inches water column (1.5 cm), measured with manometer placed on exhaust duct two feet (61 cm) from dryer (check with dryer running and no load). In multi-dryer installations, all dryers connected to the main collector duct should be operating when pressure is checked.
- Exhausting dryer in hard-to-reach locations can be done by installing 521P3 Flexible Metal Vent Kit (available as optional equipment at extra cost).
- Sufficient make-up air must be supplied to replace the air exhausted by the dryer. The free area of any opening for outside air must be at least 40 in<sup>2</sup> (260 cm<sup>2</sup>).
- Energy efficient buildings with low air infiltration rates should be equipped with an air exchanger that can accommodate on demand make-up air needs in the laundry room. These devices can be obtained through your building contractor or building material suppliers.
- Do not draw make-up air from a room containing a gas fired water heater, a dry cleaner or a hair salon.
- **Failure to exhaust dryer properly will void warranty.**

**NOTE: Venting materials are not supplied with the dryer (obtain locally).**

**IMPORTANT: DO NOT block the airflow at the bottom of the dryer's front panel with laundry, rugs, etc. Blockage will decrease airflow through the dryer, thus reducing the efficiency of the dryer.**

## Exhaust Direction

The dryer can be exhausted to the outdoors through the back, left, right or bottom of the dryer. **EXCEPTION: Gas dryers cannot be vented out the left side because of the burner housing.**

Dryer is shipped from factory ready for rear exhaust.

Exhausting the dryer through sides or bottom can be accomplished by installing a Directional Exhaust Kit, 528P3, available as optional equipment at extra cost.

### Exhaust System

For best drying results, recommended maximum length of exhaust system is shown in *Table 1*.

To prevent backdraft when dryer is not in operation, outer end of exhaust pipe must have a weather hood with hinged dampers (obtain locally).

**NOTE:** Weather hood should be installed at least 12 inches (30.5 cm) above the ground. Larger clearances may be necessary for installations where heavy snowfall can occur.

Number of 90° Elbows	Weather Hood Type	
	Recommended	Use Only for Short Run installations
	 <p>4 in. (10.2 cm)</p> <p>4 in. (10.2 cm)</p> <p>D673I</p>	 <p>2-1/2 in. (6.35 cm)</p> <p>D802I</p>
<b>Maximum length of 4 in. (10.2 cm) diameter rigid metal duct.</b>		
0	65 feet (19.8 m)	55 feet (16.8 m)
1	55 feet (16.8 m)	47 feet (14.3 m)
2	47 feet (14.3 m)	41 feet (12.5 m)
3	36 feet (11.0 m)	30 feet (9.1 m)
4	28 feet (8.5 m)	22 feet (6.7 m)
<b>Maximum length of 4 in. (10.2 cm) diameter flexible metal duct.</b>		
0	45 feet (13.7 m)	35 feet (10.7 m)
1	35 feet (10.7 m)	27 feet (8.2 m)
2	30 feet (9.1 m)	21 feet (6.4 m)
3	25 feet (7.6 m)	17 feet (5.2 m)
4	20 feet (6.1 m)	15 feet (4.5 m)
<b>NOTE: Deduct 6 feet (1.8 m) for each additional elbow.</b>		

Table 1

## Installation

### Multi-Dryer Installation Exhaust Requirements

Figure 6 shows a typical example of a multiple dryer installation. Note how each dryer has its own exhaust system vented to the central exhaust duct.

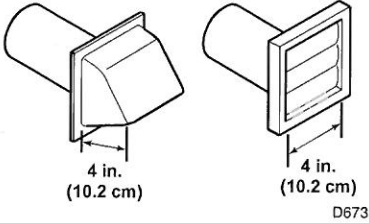
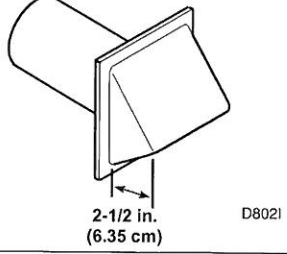
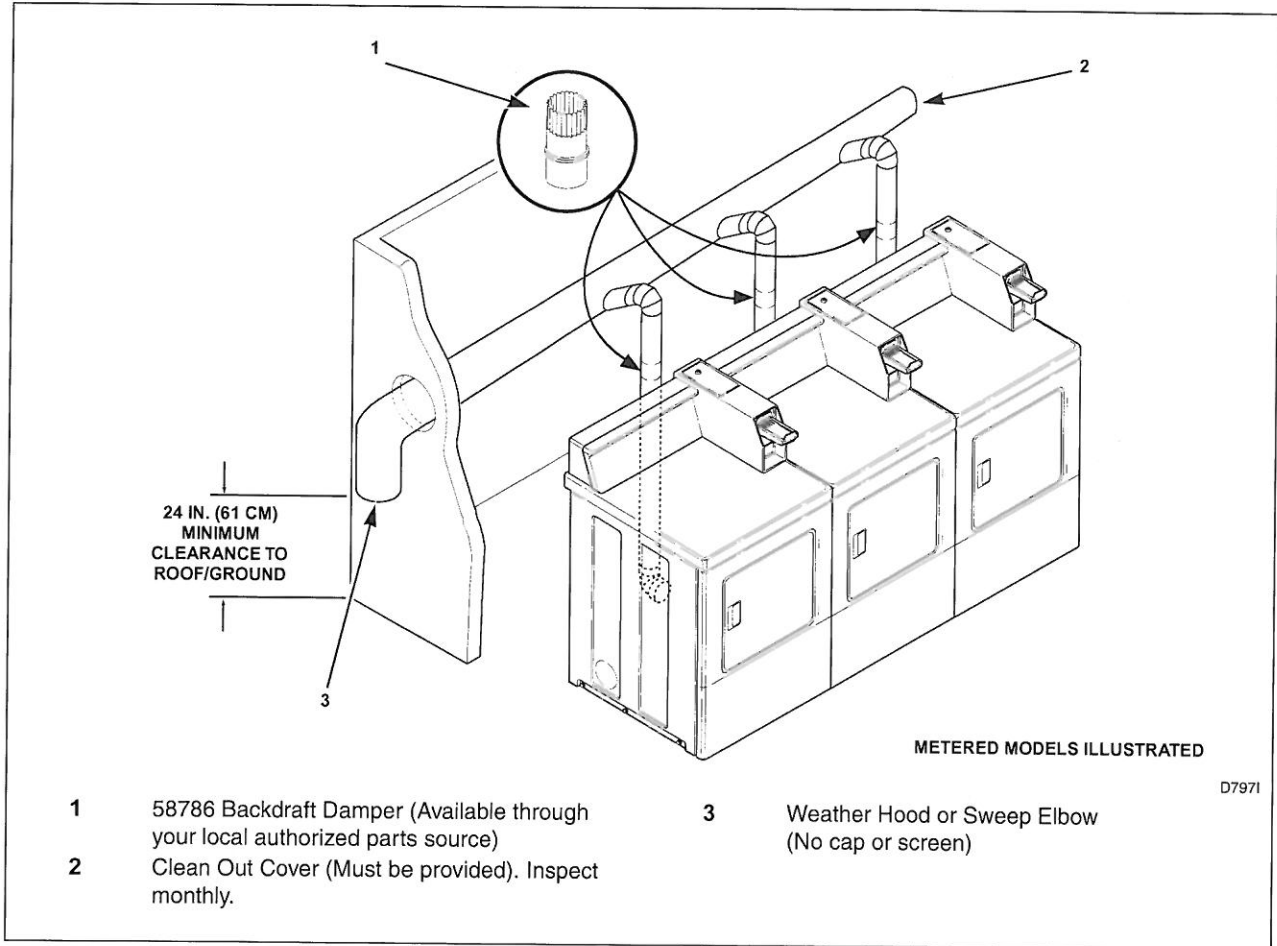

Figure 6

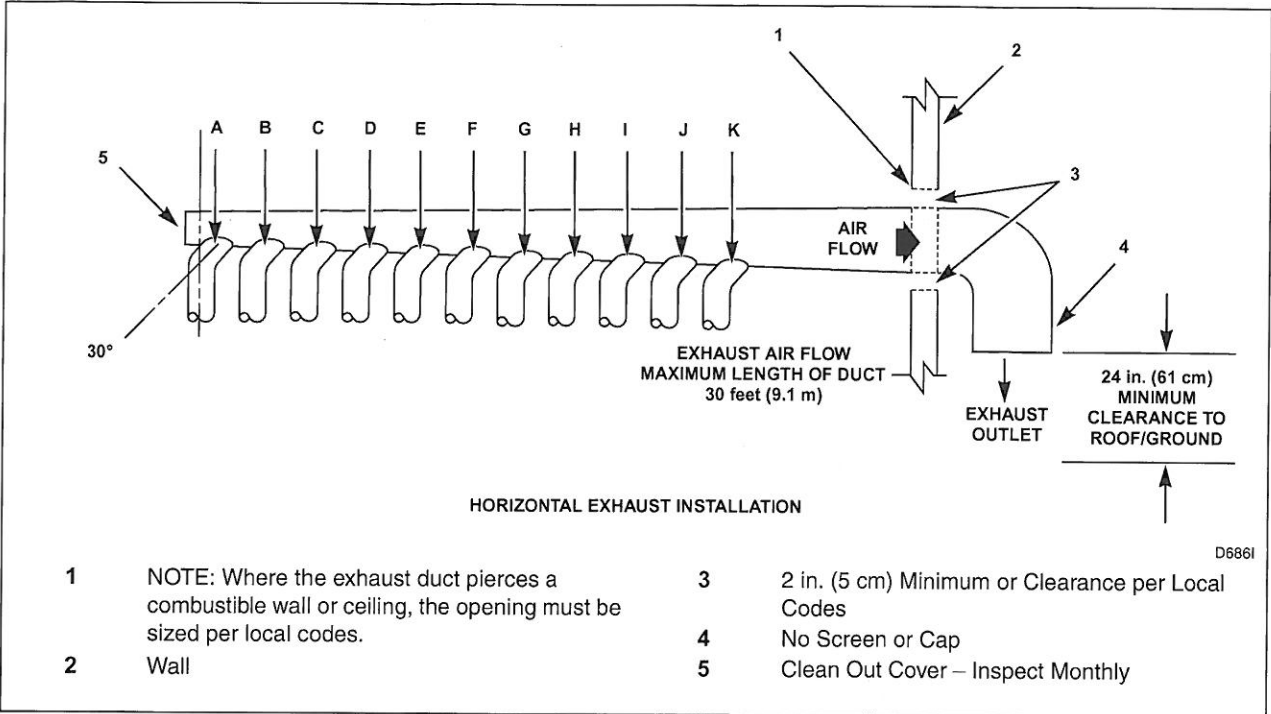

Figure 7

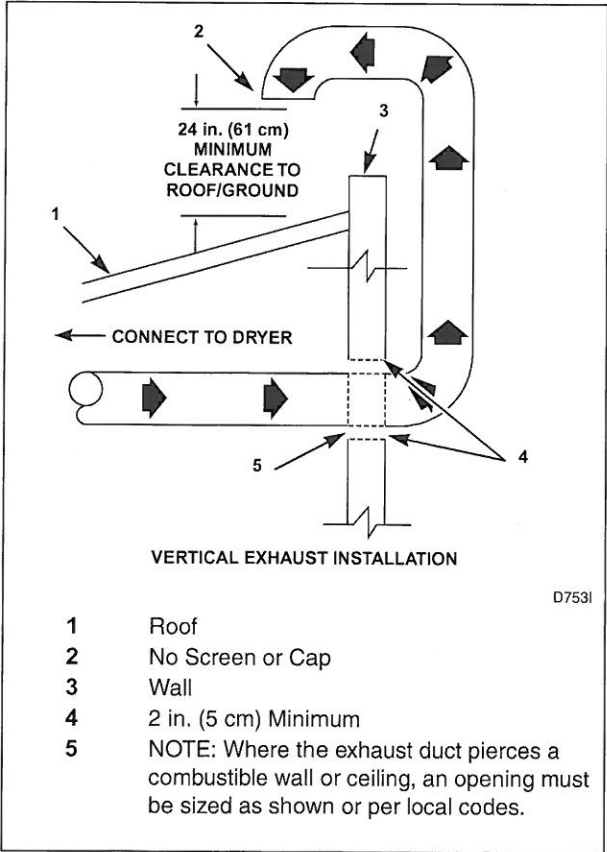

Figure 8

## WARNING

To reduce the risk of fire and the accumulation of combustion gases, **DO NOT** exhaust dryer air into a window well, gas vent, chimney or enclosed, unventilated area, such as an attic, wall, ceiling, crawl space under a building or concealed space of a building.

W045



## Installation

Duct Station	Minimum Diameter of Collector Duct
A	4 inches (10.2 cm)
B	8 inches (20.3 cm)
C	9 inches (22.9 cm)
D	10 inches (25.4 cm)
E	11 inches (27.9 cm)
F	12 inches (30.5 cm)
G	13 inches (32.6 cm)
H	14 inches (35.6 cm)
I	15 inches (38.1 cm)
J	15 inches (38.1 cm)
K	16 inches (40.6 cm)

A Backdraft Damper, Part No. 58786 (obtain locally), should be installed in a 4 inch (10.2 cm) diameter VERTICAL duct system. This will prevent a backdraft when dryer is not in use, and will keep the exhaust air in balance within the central exhaust system.

### Step 3: (Gas Dryer Only) Connect Gas Supply Pipe

	<b>WARNING</b>
<p><b>To reduce the risk of gas leaks, fire or explosion:</b></p> <ul style="list-style-type: none"> <li>• The dryer must be connected to the type of gas as shown on nameplate located in the door recess.</li> <li>• Use a new flexible stainless steel connector.</li> <li>• Use pipe joint compound insoluble in L.P. (Liquefied Petroleum) Gas, or Teflon tape, on all pipe threads.</li> <li>• Purge air and sediment from gas supply line before connecting it to the dryer. Before tightening the connection, purge remaining air from gas line to dryer until odor of gas is detected. This step is required to prevent gas valve contamination.</li> <li>• Do not use an open flame to check for gas leaks. Use a non-corrosive leak detection fluid.</li> <li>• Any disassembly requiring the use of tools must be performed by a suitably qualified service person.</li> </ul>	
W316	

1. Make certain your dryer is equipped for use with the type of gas in your laundry room. Dryer is equipped at the factory for **Natural Gas** with a 3/8 inch NPT gas connection.

**NOTE: The gas service to a gas dryer must conform with the local codes and ordinances, or in the absence of local codes and ordinances, with the latest edition of the National Fuel Gas Code ANSI Z223.1/NFPA 54 or the CAN/CGA-B149, National Gas Installation Code.**

**Natural Gas**, 1000 Btu/ft<sup>3</sup> (37.3 MJ/m<sup>3</sup>) service must be supplied at 6.5 ± 1.5 inch water column pressure.

For proper operation at altitudes above 2000 feet (610 m) the natural gas valve spud orifice size must be reduced to ensure complete combustion. Refer to *Table 2*.

<b>Natural Gas Altitude Adjustments</b>					
<b>Altitude</b>		<b>Orifice Size</b>			<b>Part Number</b>
<b>feet</b>	<b>m</b>	<b>#</b>	<b>inches</b>	<b>mm</b>	
2,000	610	41	0.0960	2.44	503776
3,000	915	42	0.0935	2.37	503777
5,500	1,680	43	0.0890	2.26	503778
7,000	2,135	44	0.0860	2.18	58719
9,000	2,745	45	0.0820	2.08	503779
10,500	3,200	46	0.0810	2.06	503780

Table 2

2. Remove the shipping cap from the gas connection at the rear of the dryer. Make sure you do not damage the pipe threads when removing the cap.

**NOTE:** When connecting to a gas line, an equipment shut-off valve must be installed within 6 feet (1.8 m) of the dryer. An 1/8 in. NPT pipe plug must be installed as shown for checking inlet pressure. Refer to *Figure 9*.

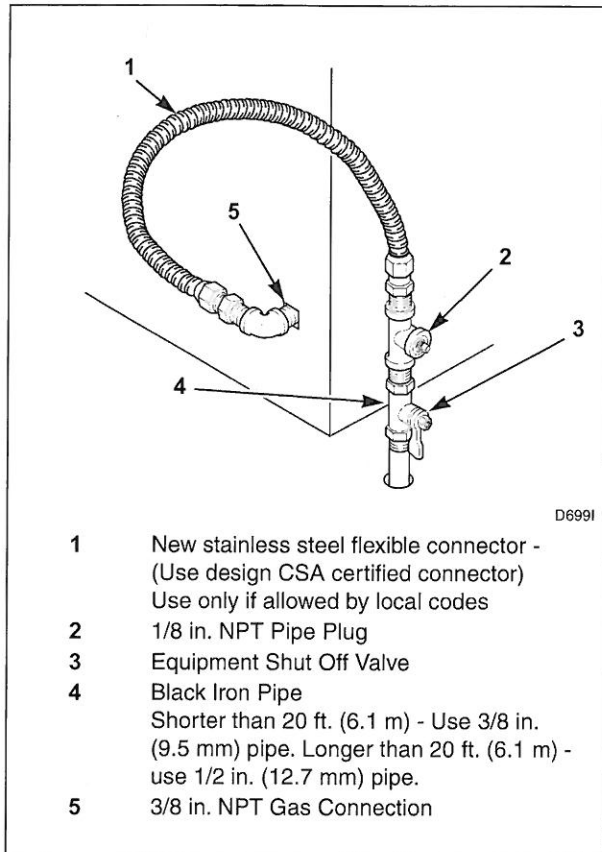

Figure 9

3. Tighten all connections securely. Turn on gas and check all pipe connections (internal & external) for gas leaks with a non-corrosive leak detection fluid.

**NOTE:** The dryer and its appliance main gas valve must be disconnected from the gas supply piping system during any pressure testing of that system at test pressures in excess of 1/2 psi (3.45 kPa). Refer to *Step 9 (Check Heat Source)*.

**L.P. (Liquefied Petroleum) Gas, 2500 Btu/ft<sup>3</sup> (93.1 MJ/m<sup>3</sup>)** service must be supplied at 10 ± 1.5 inch water column pressure.

For proper operation at altitudes above 3500 feet (1070 m) the L.P. gas valve spud orifice size must be reduced to ensure complete combustion. Refer to *Table 3*.

L.P. Altitude Adjustments					
Altitude		Orifice Size			Part No.
feet	m	No.	inches	mm	
3500	1070	54	0.0550	1.40	503785
7500	2290	55	0.0520	1.32	58755
11000	3355	56	0.0465	1.18	503786

Table 3

**NOTE: DO NOT** connect the dryer to L.P. Gas Service without converting the gas valve. Install L.P. Gas Conversion Kit 458P3, available at extra cost.

#### Step 4: (Electric Dryer Only) Connect Electrical Plug

Dryer requires 120/240 Volt or 120/208 Volt, 60 Hertz, 3 or 4 wire electrical supply. Refer to serial plate for specific electrical requirements.

**NOTE:** The wiring diagram is located inside the control hood.

	<b>WARNING</b>
<p>To reduce the risk of fire, electric shock, serious injury or death, all wiring and grounding <b>MUST</b> conform with the latest edition of the National Electrical Code, ANSI/NFPA 70, or the Canadian Electrical Code, CSA C22.1, and such local regulations as might apply. It is the customer's responsibility to have the wiring and fuses installed by a qualified electrician to make sure adequate electrical power is available to the dryer.</p>	
W521	

## Installation

### *Grounding Information*

- This dryer must be connected to a grounded metal, permanent wiring system; or an equipment-grounding conductor must be run with the circuit conductors and connected to the equipment-grounding terminal or lead on the dryer.
- The dryer has its own terminal block that must be connected to a separate branch, 60 Hertz, single phase circuit, AC (alternating current) circuit, **fused at 30 Amperes** (the circuit must be fused on both sides of the line). **Electrical service for the dryer should be of maximum rated voltage listed on the nameplate. Do not connect dryer to 110, 115, or 120 volt circuit.**
- Heating elements are available for field installation in dryers which are to be connected to electrical service of different voltage than that listed on nameplate, such as 208 Volt.
- If branch circuit to dryer is 15 feet (4.57 m) or less in length, No. 10 AWG wire (copper wire only), or as required by local codes. If over 15 feet (4.57 m), use No. 8 AWG wire (copper wire only), or as required by local codes. Allow sufficient slack in wiring so dryer can be moved from its normal location when necessary.
- The power cord connection between wall receptacle and dryer terminal block **IS NOT supplied with dryer.** Type of power cord and gauge of wire must conform to local codes.

**IMPORTANT:** Use only a new U.L. listed No. 10 (copper wire only) three conductor power supply cord kit rated 240 Volts (minimum) 30 Amperes and labeled as suitable for use in a clothes dryer.

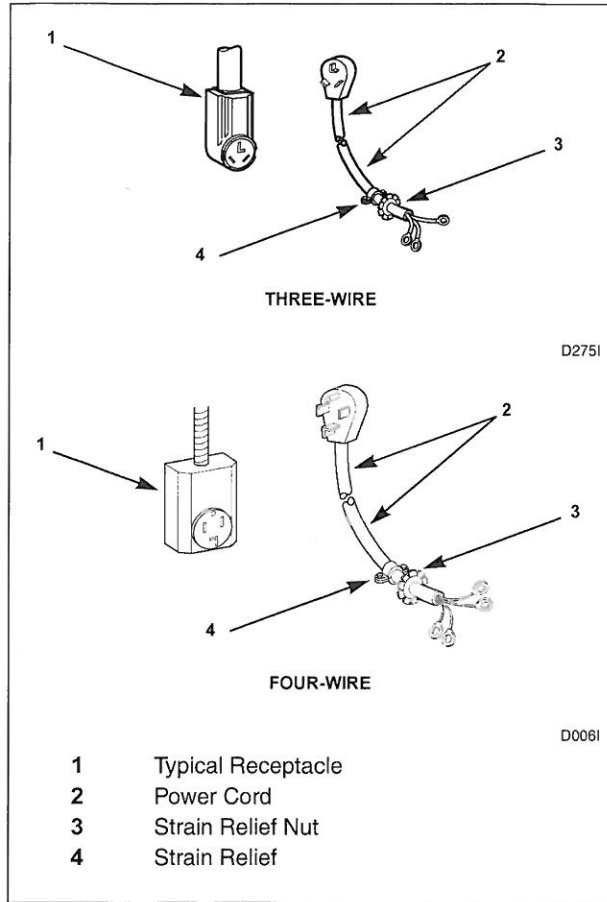

Figure 10

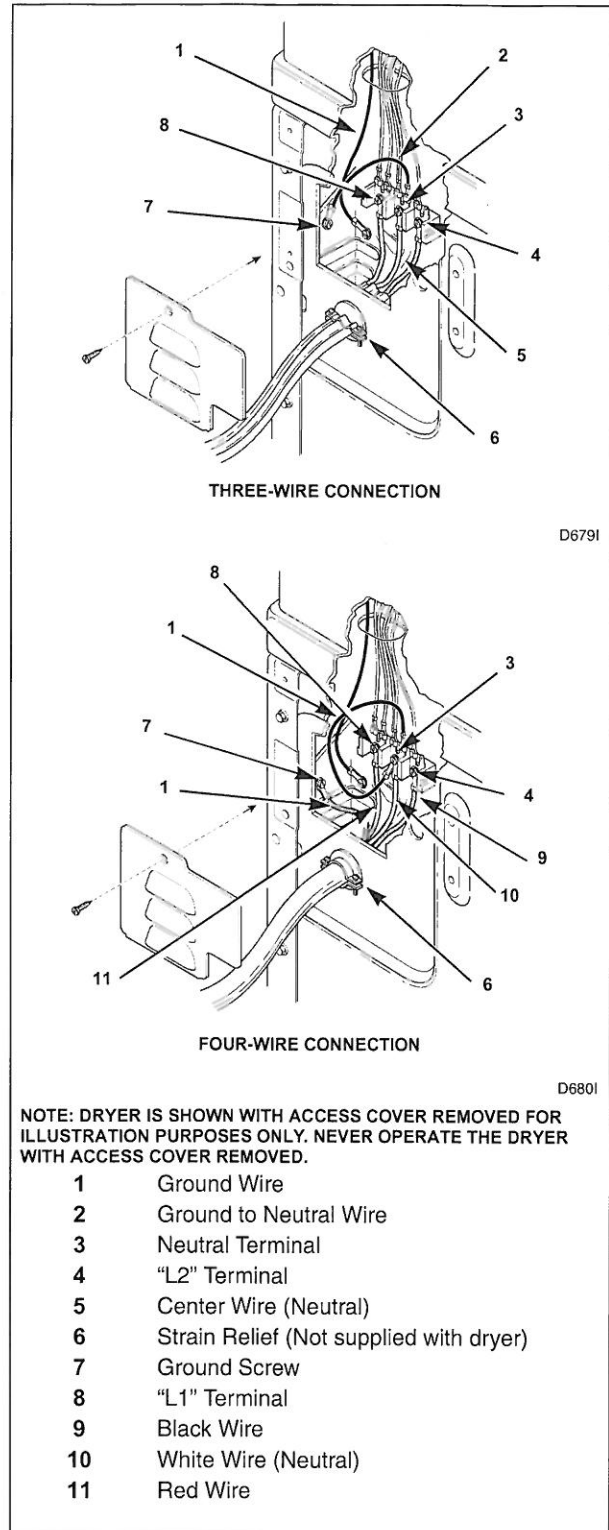

Figure 11

**Installation**

*Connecting Power Cord with Three-Wire Plug*

**NOTE: Four-wire cord is required for mobile homes or where codes do not permit grounding through neutral.**

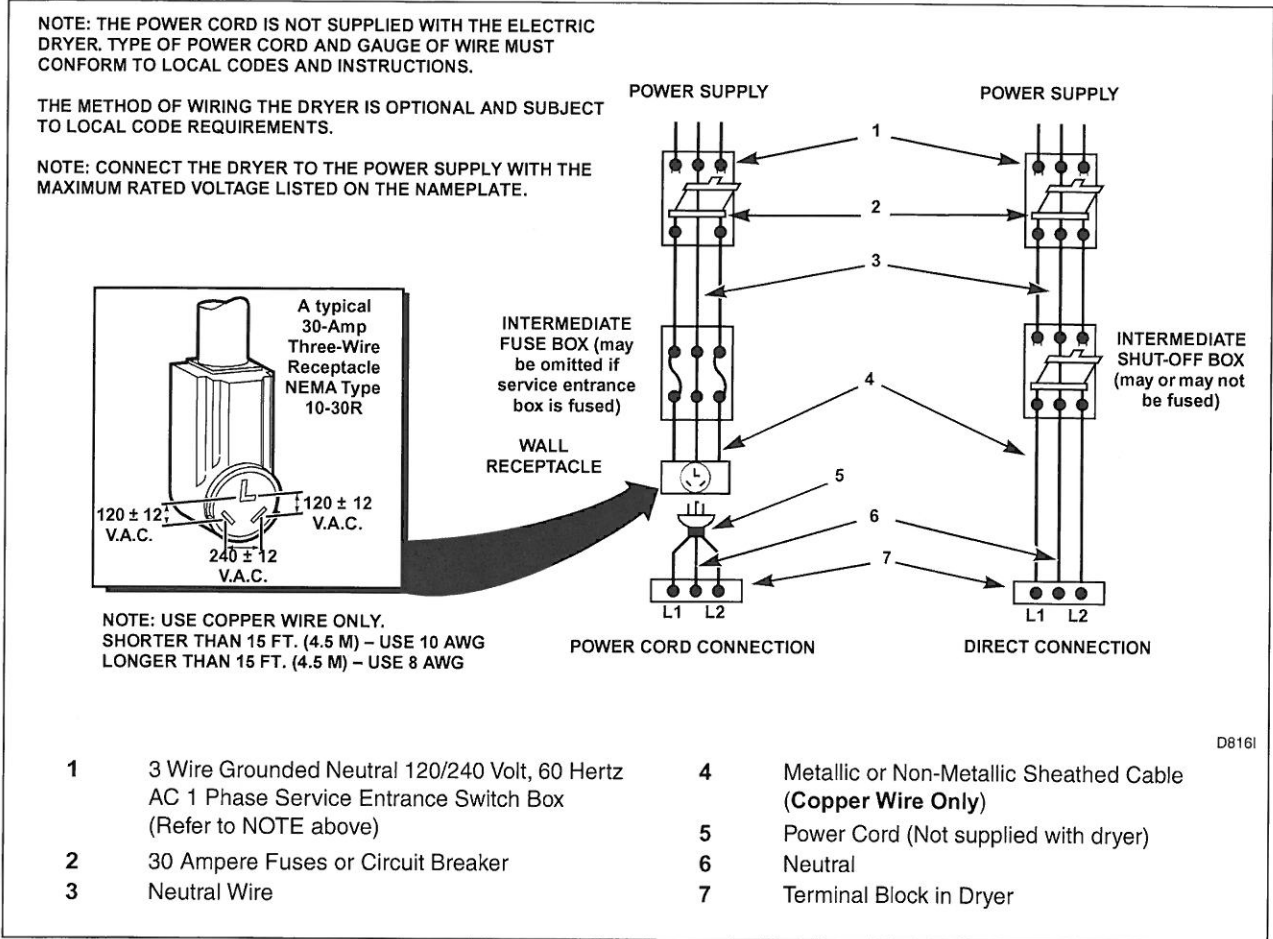

Figure 12

1. Disconnect power to dryer.
2. Remove access cover from rear of dryer.
3. Use a strain relief and insert end of power cord through power supply hole.

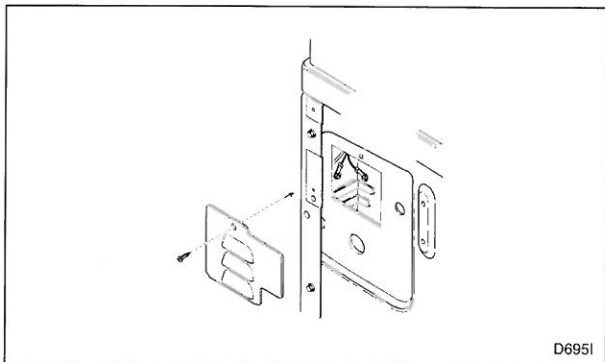

Figure 13

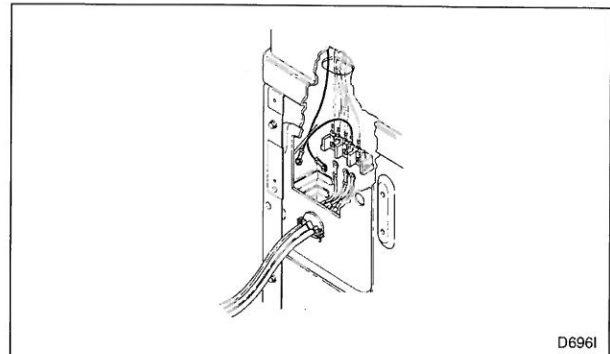

Figure 14

- 4. Use the three screws from the accessories bag to attach the power cord wires to the terminal block. Refer to *Figure 15*.

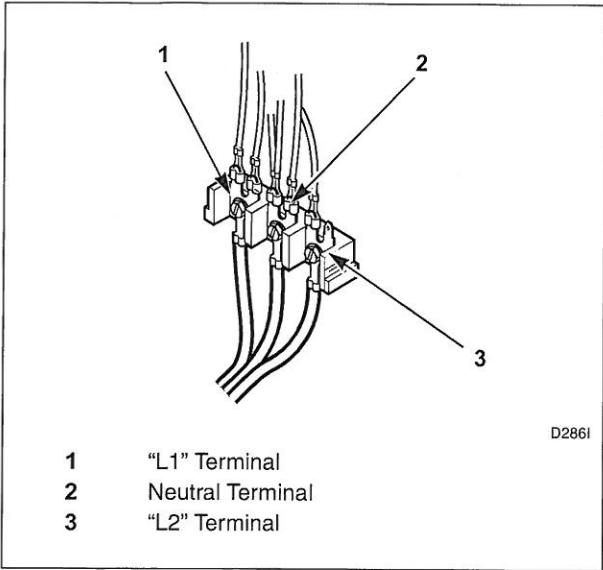

Figure 15

- 5. Tighten all screws firmly.

**IMPORTANT: Failure to tighten these screws firmly may result in wire failure at the terminal block.**

- 6. Secure the strain relief to the power cord, or wires, where they enter the dryer cabinet.
- 7. Check the continuity of the ground connection before plugging the cord into an outlet. Use an acceptable indicating device connected to the center grounding pin of the plug and the green screw on the back of the cabinet.
- 8. Reinstall access cover and screw.

*Connecting Power Cord with Four-Wire Plug*

**NOTE: Four-wire cord is required for mobile homes or where codes do not permit grounding through neutral.**

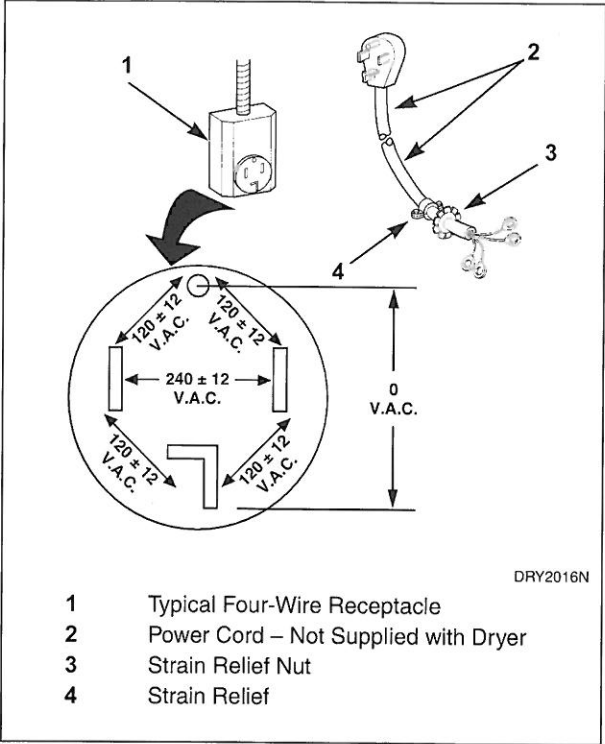

Figure 16

## Installation

1. Disconnect power to dryer.
2. Remove access cover from rear of dryer.

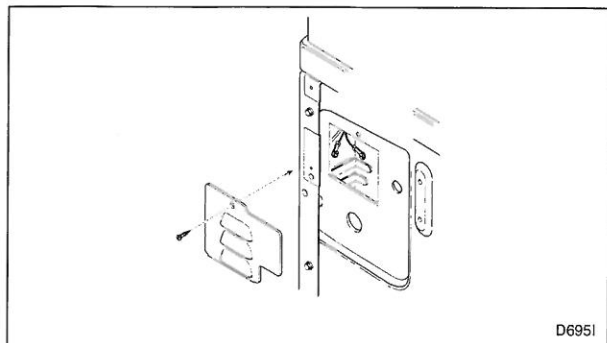

Figure 17

3. Remove ground screw and save for use in Step 5. Remove wire and use in Step 6.

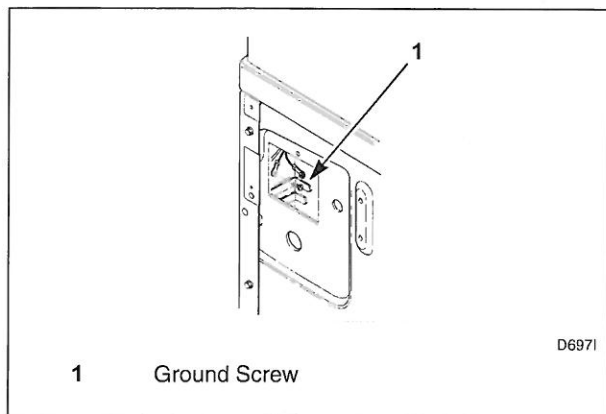

Figure 18

4. Use a strain relief and insert end of power cord through power supply hole.

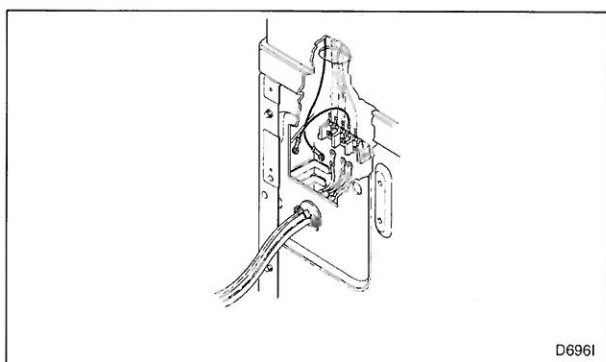

Figure 19

5. Attach power cord ground (green) wire to rear bulkhead using ground screw removed in Step 3.

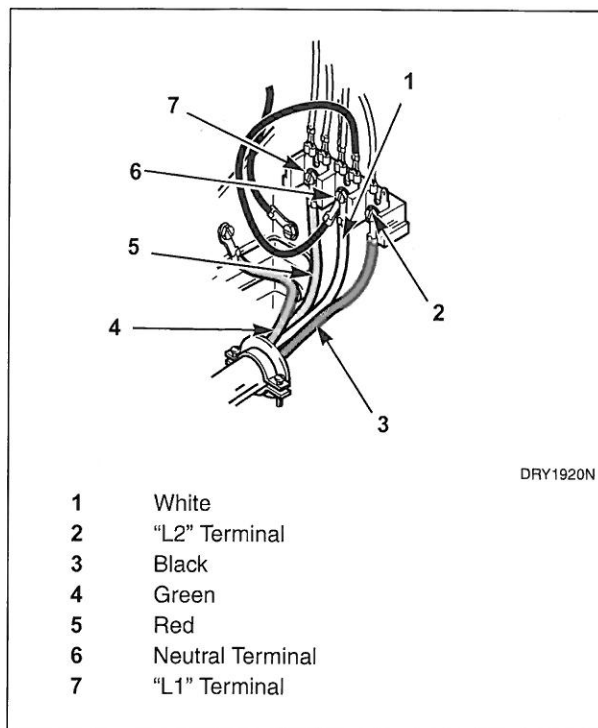

Figure 20

6. Use the three screws from the accessories bag to attach the remaining power cord wires to the terminal block as follows:
  - a. Red wire to "L1" terminal.
  - b. Black wire to "L2" terminal.
  - c. White wire to Neutral terminal.

**NOTE:** When installing the white wire, loop the free eyelet end of the ground wire (removed in Step 3) and attach along with the white wire to the neutral (center) terminal on the terminal block.

7. Tighten all screws firmly.

**IMPORTANT:** Failure to tighten these screws firmly may result in wire failure at the terminal block.

8. Secure the strain relief to the power cord, or wires, where they enter the dryer cabinet.
9. Check the continuity of the ground connection before plugging the cord into an outlet. Use an acceptable indicating device connected to the center grounding pin of the plug and the green screw on the back of the cabinet.
10. Reinstall access cover and screw.

**Step 5: Reverse Door, if Desired**

The door on this dryer is completely reversible. To reverse door proceed as follows:

1. Remove four hinge attaching screws.

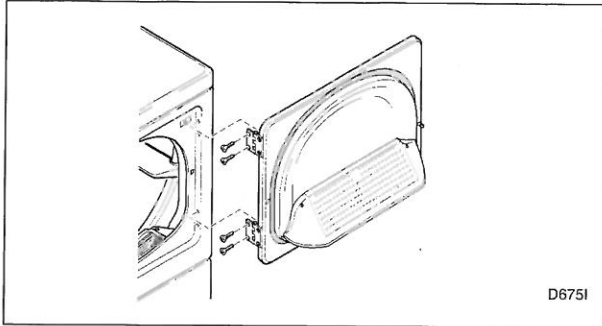

Figure 21

2. Remove all nine screws.

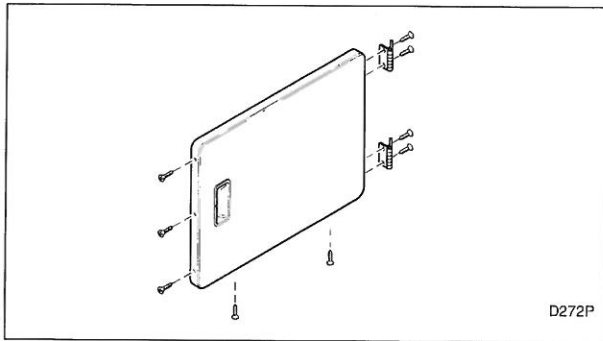

Figure 22

3. Pull bottom of door liner out, then pull down, removing door liner from door panel.

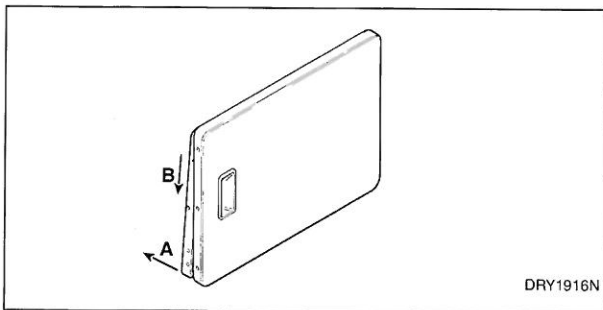

Figure 23

4. Rotate door panel 180 degrees as shown.

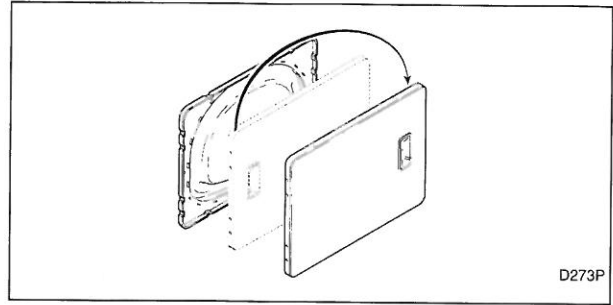

Figure 24

5. Remove door strike from door liner and reinstall on opposite side.

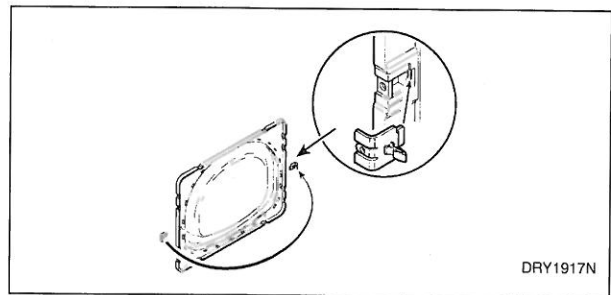

Figure 25

6. Insert liner under flange on bottom of door, then push top of door liner into place.

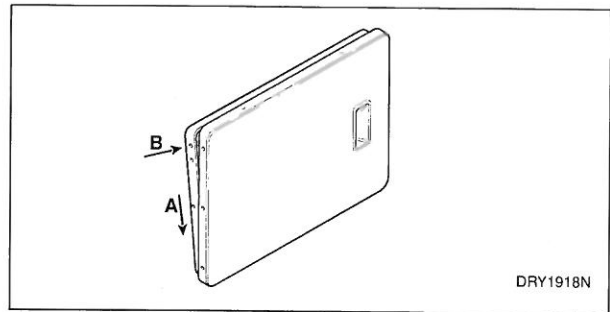

Figure 26

7. Reinstall nine screws removed in Step 2.

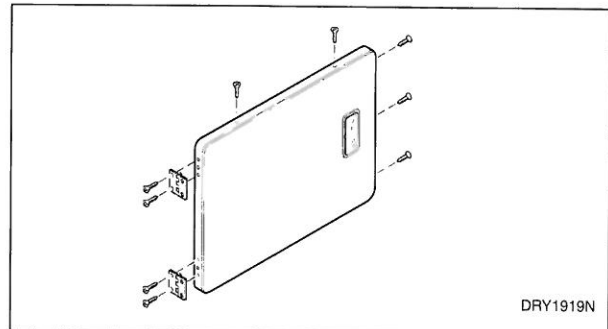

Figure 27



## Installation

- Using screwdriver, remove two door plugs, and reinstall on opposite side of door opening.

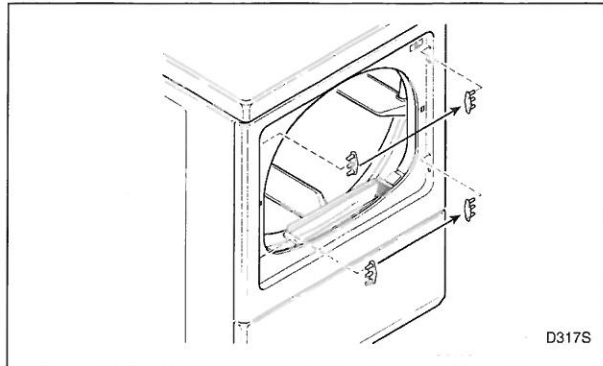

Figure 28

- Reinstall four hinge attaching screws, removed in Step 1.

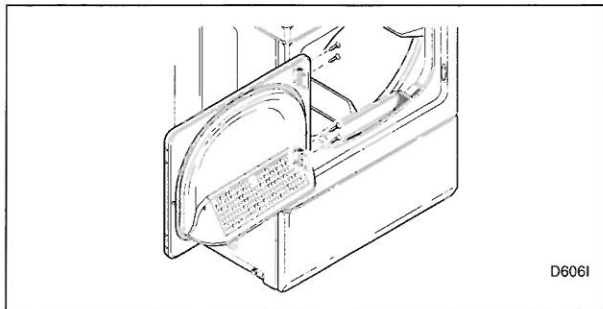

Figure 29

### Step 6: Wipe Out Inside of Dryer

Before using dryer for the first time, use an all-purpose cleaner, or a detergent and water solution, and a damp cloth to remove shipping dust from inside dryer drum.

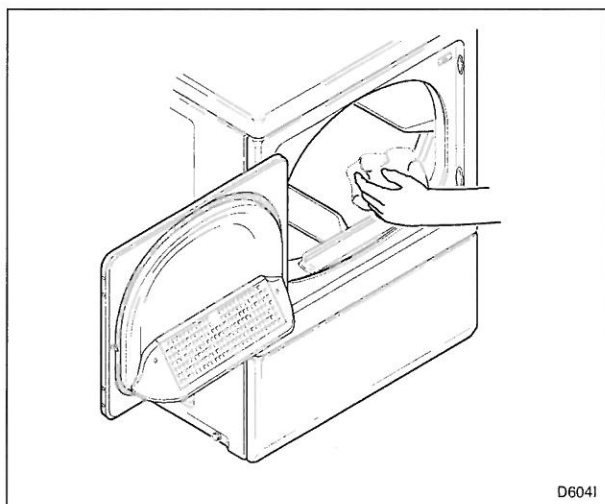

Figure 30

### Step 7: Plug In the Dryer

#### Electric Dryer

Connect the dryer to an electrical power source. Refer to Step 4 for information on connecting power cord.

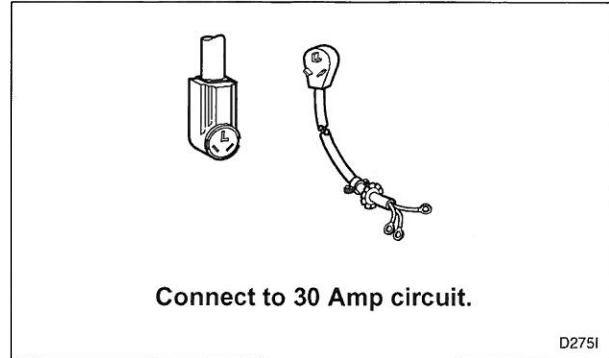

Figure 31

#### Gas Dryer

Dryer requires 120 Volt, 60 Hertz electrical supply and comes equipped with a 3-prong grounding plug. Refer to serial plate for specific electrical requirements.

**NOTE: The wiring diagram is located inside the control hood.**



## WARNING

To reduce the risk of fire, electric shock, serious injury or death, all wiring and grounding **MUST** conform with the latest edition of the National Electrical Code, ANSI/NFPA 70, or the Canadian Electrical Code, CSA C22.1, and such local regulations as might apply. It is the customer's responsibility to have the wiring and fuses installed by a qualified electrician to make sure adequate electrical power is available to the dryer.

W521

When plugging in the dryer:

- Do not overload circuits.
- Do not use an adapter.
- Do not use an extension cord.
- Do not operate both a washer and gas dryer on the same circuit. Use separately fused 15 amp circuits.

The dryer is designed to be operated on a separate branch, polarized, three-wire, effectively grounded, 120 Volt, 60 Hertz, AC (alternating current) circuit protected by a **15 Ampere fuse**, equivalent fuse-tron or circuit breaker.

The three-prong grounding plug on the power cord should be plugged directly into a polarized three-slot effectively grounded receptacle rated 120 Volts AC (alternating current) 15 Amps. Refer to *Figure 32* to determine correct polarity of the wall receptacle.

**Grounding Information**

The dryer must be grounded. In the event of malfunction or breakdown, grounding will reduce the risk of electric shock by providing a path of least resistance for electric current. The dryer is equipped with a cord having an equipment-grounding conductor and a 3 prong grounding plug. The three-prong grounding plug on the power cord should be plugged directly into a polarized three-slot effectively grounded receptacle rated 110/120 Volts AC (alternating current) 15 Amps.

Do not operate other appliances on the same circuit when this appliance is operating.

	<b>WARNING</b>
<p><b>To reduce the risk of an electric shock or fire, DO NOT use an extension cord or an adapter to connect the dryer to the electrical power source.</b></p>	
W037	

	<b>WARNING</b>
<p><b>This dryer is equipped with a three-prong (grounding) plug for your protection against shock hazard and should be plugged directly into a properly grounded three-prong receptacle. Do not cut or remove the grounding prong from this plug.</b></p>	
W036	

	<b>WARNING</b>
<p><b>Improper connection of the equipment-grounding conductor can result in a risk of electric shock. Check with a qualified electrician or service person if you are in doubt as to whether the dryer is properly grounded.</b></p>	
W038	

Do not modify the plug provided with the dryer – if it will not fit the outlet, have a proper outlet installed by a qualified electrician.

**NOTE: Have a qualified electrician check the polarity of the wall receptacle. If a voltage reading is measured other than that illustrated, the qualified electrician should correct the problem.**

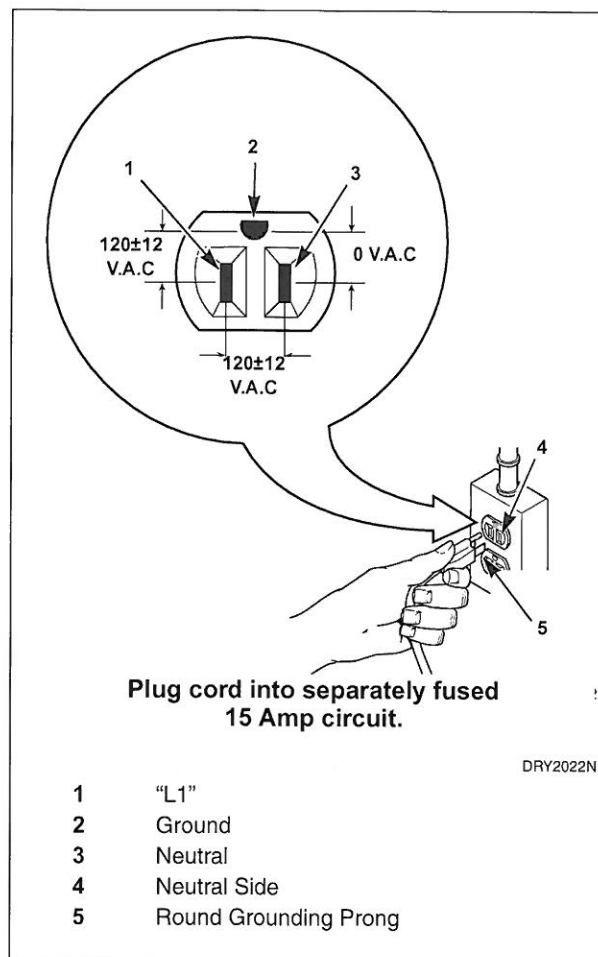

Figure 32

## Installation

### Step 8: Recheck Steps 1-7

Refer to *Installer Checklist* on the back cover of this manual and make sure that dryer is installed correctly.

### Step 9: Check Heat Source

#### Electric Dryers

Close the loading door and start the dryer in a heat setting (refer to the *Operation* section). After the dryer has operated for three minutes, the exhaust air or exhaust pipe should be warm.

#### Gas Dryers

**IMPORTANT: This operation is to be conducted by qualified personnel only.**

To view the burner flame, remove the lower front panel of the dryer.

Close the loading door, start the dryer in a heat setting (refer to the *Operation* section). The dryer will start, the igniter will glow red and the main burner will ignite.

**IMPORTANT: If all air is not purged out of gas line, gas igniter may go off before gas is ignited. If this happens, after approximately two minutes igniter will again attempt gas ignition.**

**IMPORTANT: If igniter does not light, make sure gas is turned on.**

After the dryer has operated for approximately five minutes, observe burner flame through lower front panel. Adjust the air shutter to obtain a soft, uniform blue flame. (A lazy, yellow-tipped flame indicates lack of air. A harsh, roaring, very blue flame indicates too much air.) Adjust the air shutter as follows:

1. Loosen the air shutter lockscrew.
2. Turn the air shutter to the left to get a luminous yellow-tipped flame, then turn it back slowly to the right to obtain a steady, soft blue flame.
3. After the air shutter is adjusted for proper flame, tighten the air shutter lockscrew securely.
4. Reinstall the lower front panel.

	<b>WARNING</b>
<b>For personal safety, lower front panel must be in place during normal operation.</b>	
<small>W046</small>	

After the dryer has operated for approximately three minutes, exhaust air or exhaust pipe should be warm.

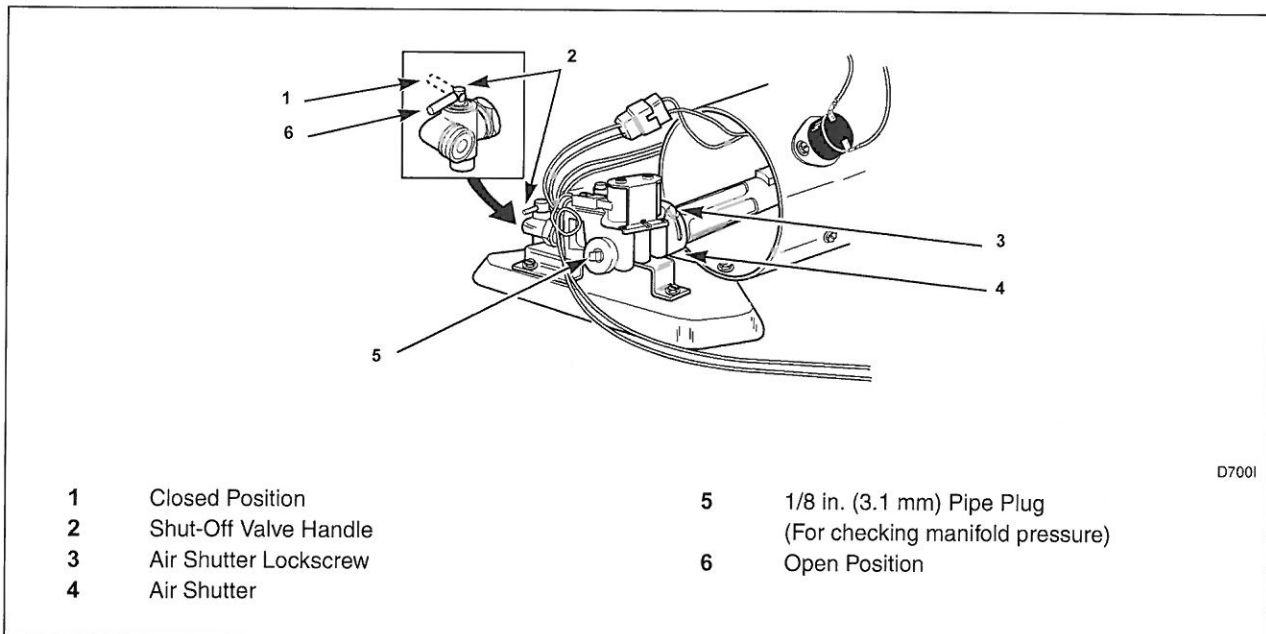

Figure 33

# Vending

## Meter Case

### (Metered Models)

The factory mounted coin meter case does not include the service door lock, coin drawer, coin drawer lock and keys. These parts must be ordered (at extra cost) according to the purchaser's requirements direct from the manufacturer of your choice.

**NOTE: You have the option of using a screw type lock or a 1/4 turn lock on the meter case service door. If you choose to use a screw lock, then the special bracket (located inside the meter case) must be used. DO NOT use the special bracket if a 1/4 turn lock is used.**

**Coin Drawer Security** – for additional security, drill out the two pilot holes on each front side of the meter case to 1/4 or 5/16 inch (6.4 or 8.0 mm) holes and install a bicycle lock through these holes.

## Coin Slide Control

### (Coin Slide Models Only)

#### Power-Up Mode

When power is applied to the dryer, the control will enter the Ready Mode. If the control was powered down during a running a cycle, the *IN USE* LED will flash once and the control will enter Start Mode. If the dry time dipswitch settings have not been changed from factory default, the *IN USE* LED will flash once.

#### Ready Mode

In Ready Mode, the control waits for the vend to be satisfied before entering Start Mode.

#### Start Mode

In Start Mode, the vend has been satisfied, but the Start button has not been pressed. The *IN USE* LED will be lit. The timer will not count down until the Start button is pressed.

#### Run Mode

In Run Mode, the control is running a cycle. The *IN USE* LED is lit.

## Door Open Mode

In Door Open Mode, the control turns off the heater and motor when the door is opened during a run cycle. The timer will continue to count down time and the *IN USE* LED is lit.

## End of Cycle Mode

In End of Cycle Mode, a cycle is complete and the *IN USE* LED is off. The control remains in this mode until the door is opened or additional vend has been satisfied.

## Topoffs

Any time the control receives a coin slide pulse during a cycle it will add the programmed dry time to the time currently remaining in the cycle. The *IN USE* LED will flash briefly to indicate the coin input. The maximum cycle time is 99 minutes. The control will not add time beyond 99 minutes. The cool down time will not change. If the control receives a coin slide pulse during cool down it will exit cool down and start heating with the cycle time equal to the programmed time.

## Temperature Selector Switch

For five minutes after the control is powered up, there is a diagnostic feature that allows the temperature selector switches to be tested. When the temperature selector is changed, the new setting is displayed by flashing the *IN USE* LED as follows:

High/Normal: 4 flashes

Medium/PP or Casual: 3 flashes

Low/Delicate: 2 flashes

No Heat: 1 flash

## Vending

### Error Display Mode

The control enters Error Display Mode to display thermistor errors. The heater is turned off, the *IN USE* LED flashes to indicate the error (refer to paragraphs below), and the timer will continue to count down time. The control remains in Error Display Mode until the control senses the thermistor has returned to an acceptable heating range, the cycle ends or machine is powered down.

#### *Open Thermistor*

If the control senses a temperature less than 0°F when the heat has been on for at least three minutes it will set an open thermistor error. The control will flash the *IN USE* LED twice separated by a one and a half second pause. This sequence is repeated as long as the Open Thermistor error is sensed.

#### *Shorted Thermistor*

If the control senses a temperature greater than  $210 \pm 4$ °F during an active cycle it will set a Shorted Thermistor error. The control will flash the *IN USE* LED three times separated by a one and a half second pause. This sequence is repeated as long as the Shorted Thermistor error is sensed.

### Setting Dry Time Dipswitches

To change the dry time on the dryer, combinations of dipswitches can be set on the control. Refer to *Figure 34*.

There are eight dipswitches on the dryer control. The first six switches are used to program the amount of additional heat time given for each coin pulse. The additional drying time is added to the factory default minimum heat time of one minute. A value of 1 to 63 minutes of additional drying time is available for each coin slide pulse.

The last two switches are used to program the amount of additional cool down time. The additional cool down time is added to the factory default minimum cool down time of 3 minutes. A value of 1 to 3 additional minutes is available.

The control is shipped from the factory programmed with 1 minute of minimum heat time, preset with 41 additional minutes of drying time (dipswitches 1, 4 and 6 in ON position) and 3 minutes of minimum cool down time for a total time of 45 minutes for a coin pulse. Refer to *Table 4* for dipswitch settings.

The control reads the dipswitch settings at power-up. The control must be powered down to change the dipswitch settings.

To change the heat or cool down time for a coin pulse, the desired dry time dipswitches must be set to ON position. All other dipswitches must be in OFF position.

## Dipswitch Settings

Heat Time Per Coin Pulse (in minutes)	Heat Switch Number					
	1	2	3	4	5	6
1	OFF	OFF	OFF	OFF	OFF	OFF
2	ON	OFF	OFF	OFF	OFF	OFF
3	OFF	ON	OFF	OFF	OFF	OFF
4	ON	ON	OFF	OFF	OFF	OFF
5	OFF	OFF	ON	OFF	OFF	OFF
6	ON	OFF	ON	OFF	OFF	OFF
7	OFF	ON	ON	OFF	OFF	OFF
8	ON	ON	ON	OFF	OFF	OFF
9	OFF	OFF	OFF	ON	OFF	OFF
10	ON	OFF	OFF	ON	OFF	OFF
11	OFF	ON	OFF	ON	OFF	OFF
12	ON	ON	OFF	ON	OFF	OFF
13	OFF	OFF	ON	ON	OFF	OFF
14	ON	OFF	ON	ON	OFF	OFF
15	OFF	ON	ON	ON	OFF	OFF
16	ON	ON	ON	ON	OFF	OFF
17	OFF	OFF	OFF	OFF	ON	OFF
18	ON	OFF	OFF	OFF	ON	OFF
19	OFF	ON	OFF	OFF	ON	OFF
20	ON	ON	OFF	OFF	ON	OFF
21	OFF	OFF	ON	OFF	ON	OFF
22	ON	OFF	ON	OFF	ON	OFF
23	OFF	ON	ON	OFF	ON	OFF
24	ON	ON	ON	OFF	ON	OFF
25	OFF	OFF	OFF	ON	ON	OFF
26	ON	OFF	OFF	ON	ON	OFF
27	OFF	ON	OFF	ON	ON	OFF
28	ON	ON	OFF	ON	ON	OFF
29	OFF	OFF	ON	ON	ON	OFF
30	ON	OFF	ON	ON	ON	OFF
31	OFF	ON	ON	ON	ON	OFF
32	ON	ON	ON	ON	ON	OFF
33	OFF	OFF	OFF	OFF	OFF	ON
34	ON	OFF	OFF	OFF	OFF	ON
35	OFF	ON	OFF	OFF	OFF	ON
36	ON	ON	OFF	OFF	OFF	ON
37	OFF	OFF	ON	OFF	OFF	ON
38	ON	OFF	ON	OFF	OFF	ON

Table 4 (continued)

Vending

Table 4 (continued)

Heat Time Per Coin Pulse (in minutes)	Heat Switch Number					
	1	2	3	4	5	6
39	OFF	ON	ON	OFF	OFF	ON
40	ON	ON	ON	OFF	OFF	ON
41	OFF	OFF	OFF	ON	OFF	ON
42 (preset at factory)	ON	OFF	OFF	ON	OFF	ON
43	OFF	ON	OFF	ON	OFF	ON
44	ON	ON	OFF	ON	OFF	ON
45	OFF	OFF	ON	ON	OFF	ON
46	ON	OFF	ON	ON	OFF	ON
47	OFF	ON	ON	ON	OFF	ON
48	ON	ON	ON	ON	OFF	ON
49	OFF	OFF	OFF	OFF	ON	ON
50	ON	OFF	OFF	OFF	ON	ON
51	OFF	ON	OFF	OFF	ON	ON
52	ON	ON	OFF	OFF	ON	ON
53	OFF	OFF	ON	OFF	ON	ON
54	ON	OFF	ON	OFF	ON	ON
55	OFF	ON	ON	OFF	ON	ON
56	ON	ON	ON	OFF	ON	ON
57	OFF	OFF	OFF	ON	ON	ON
58	ON	OFF	OFF	ON	ON	ON
59	OFF	ON	OFF	ON	ON	ON
60	ON	ON	OFF	ON	ON	ON
61	OFF	OFF	ON	ON	ON	ON
62	ON	OFF	ON	ON	ON	ON
63	OFF	ON	ON	ON	ON	ON
64	ON	ON	ON	ON	ON	ON

Cool Down Per Cycle (in minutes)	Cool Down Switch Number	
	7	8
3 (preset at factory)	OFF	OFF
4	ON	OFF
5	OFF	ON
6	ON	ON

Table 4

Total Cycle Time = Heat Time + Cool Down Time

## Test Setting

When testing coin slide operation or other troubleshooting, set dipswitch with this shorter cycle:

1. Unplug the machine power cord.
2. Record the machine control dipswitch settings. Then set them all to the off position. Refer to *Figure 34*.

3. Plug in the machine and initiate a cycle.

**NOTE: With all the control dipswitches off, the total cycle time will be four minutes long.**

4. Once all the testing is complete, unplug the machine and re-set the dipswitches to their original settings.
5. Plug in the machine.

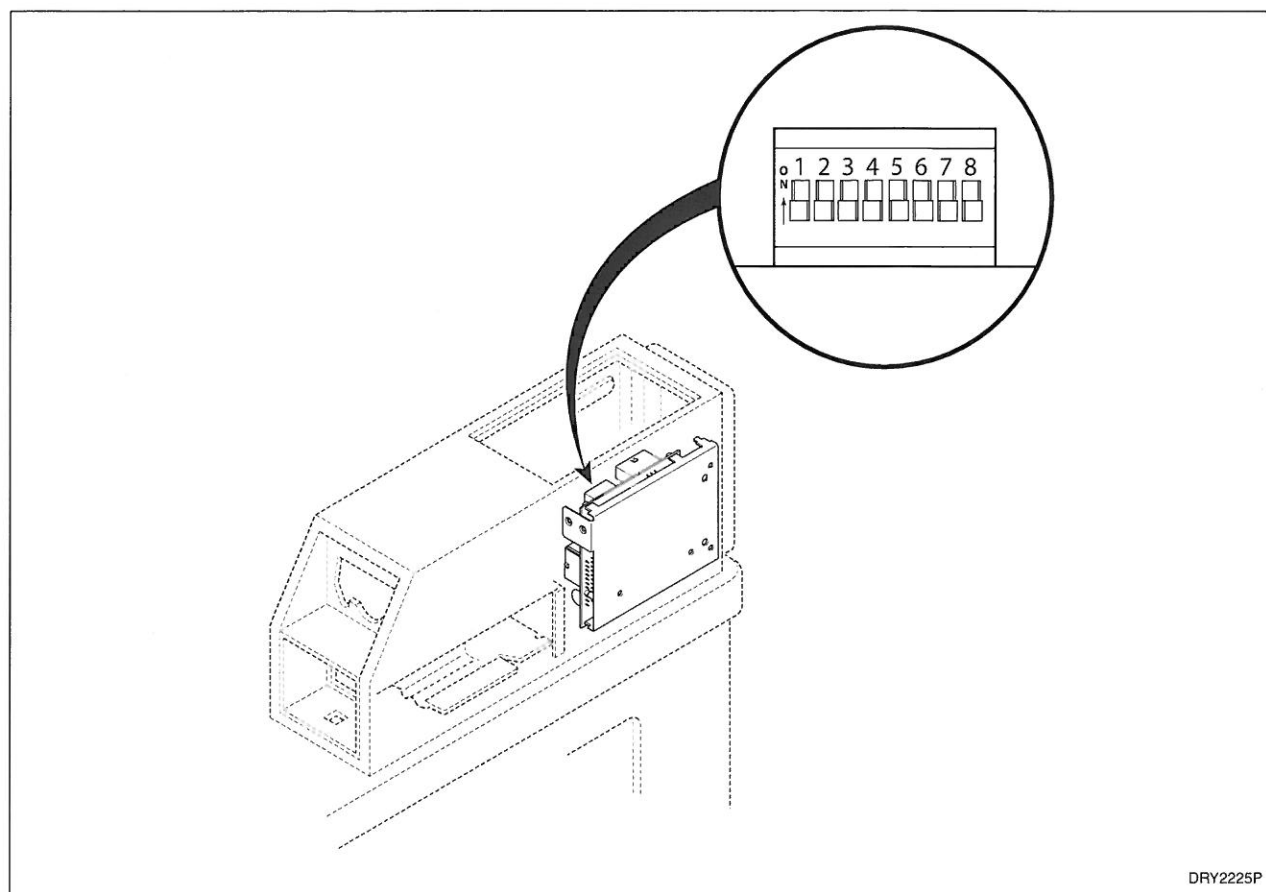

Figure 34



## Vending

### Slide Extension

#### (Coin Slide Models Only)

1. Remove slide extension parts from parts accessories bag included in unit.
2. If installing a Greenwald coin slide, position extension lever (to be installed on extension bracket) with arm that has one star facing down. Refer to *Figure 35*.

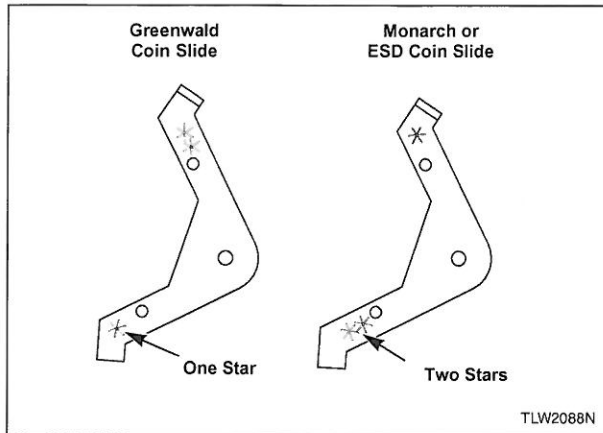

Figure 35

3. If installing a Monarch or ESD coin slide, position lever with arm that has two stars facing down. Refer to *Figure 35*.
4. Install extension lever with rounded corner facing away from extension bracket using bolt, one or two flat washers (shims) (use number of washers included in kit) and nut. Refer to *Figure 36*. Make sure washers are flat against bracket.

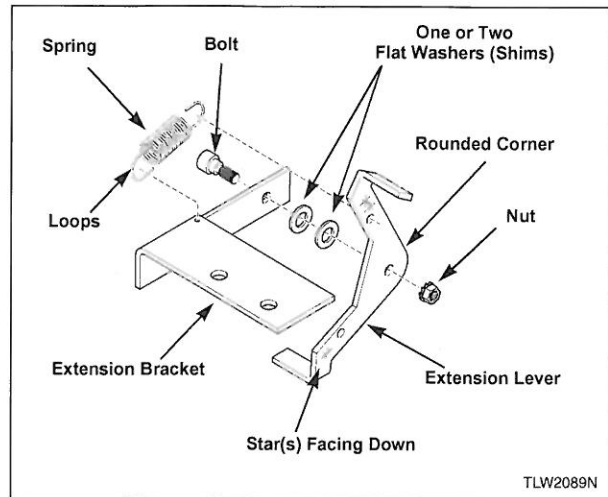

Figure 36

5. Torque nut between 2 and 2.26 Nm (18 and 20 inch-pounds), or tighten nut firmly.
6. Install extension spring in bracket hole and hole in upper arm of lever. Refer to *Figure 36*.
7. Bend loops closed after installation.
8. Check to make sure the lever swings freely.

*Installing Extension Onto Coin Slide:  
Option 1*

1. Install slide extension onto top of coin slide using two remaining screws and lockwashers. Refer to *Figure 37*.

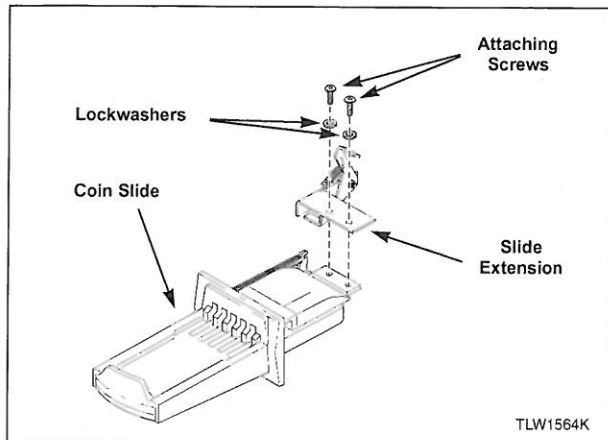

Figure 37

2. Insert coins and partially extend coin slide.
3. Insert coin slide on its side through meter case opening. Then rotate 90 degrees to its proper orientation.
4. Return coin slide and hook slide pins onto meter case.
5. Continue coin slide installation according to manufacturer's instructions.

**NOTE:** During coin slide installation, make sure activation lever is up and off the switch. Refer to *Figure 38*.

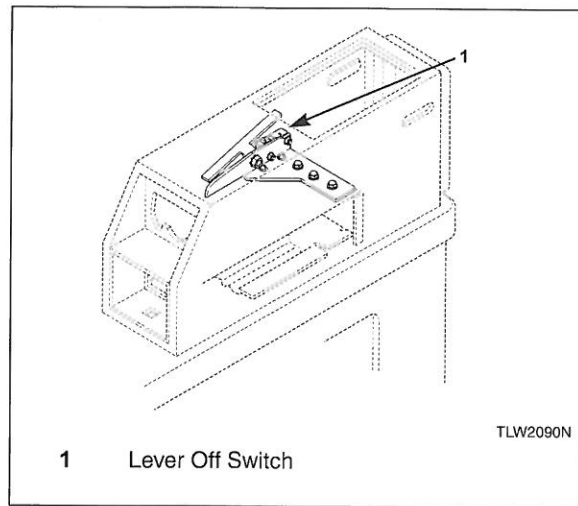

Figure 38

6. Check to make sure coin slide is operating properly by inserting coins and starting a cycle. The IN USE light will turn on, or flash if it is already on, to indicate proper operation.

**NOTE:** To avoid long run-down time (45 minutes factory default) when testing operation, refer to *Test Setting* section.

*Installing Extension Onto Coin Slide:  
Option 2*

1. Install coin slide according to manufacturer's instructions.
2. Insert coins into coin slide and slowly push slide in. Stop before coins fall into coin box. This will allow installing extension through meter case service door opening.
3. Install slide extension onto top of coin slide using two screws and lockwashers. Refer to *Figure 37*.

**NOTE:** Make sure extension lever is above switch activation lever.

4. Check to make sure coin slide is operating properly by inserting coins and starting a cycle. The IN USE light will turn on, or flash if it is already on, to indicate proper operation.

**NOTE:** To avoid long run-down time (45 minutes factory default) when testing operation, refer to *Test Setting* section.

## Vending

### Additional Dryer Security

Located on the service door of the dryer is a flat Phillips head screw. During shipment, this screw is used to attach the service door to the meter case. For additional security, this screw can be reinstalled inside the control hood of your dryer. Following is the procedure for installing this screw:

1. Remove the Phillips head screw from service door. (Refer to *Figure 39*.)
2. Remove two screws holding control panel to control hood.
3. Tilt control panel forward and lay on a protective pad to prevent scratching of cabinet top.
4. Insert Phillips head screw down through double "D" hole in left rear corner of cabinet top (inside control hood) until it engages retainer nut located on left rear corner gusset of cabinet.
5. Finger tighten screw.

**IMPORTANT: Do not use a power driver to tighten screw. Torque of a power driver could over-tighten screw causing damage to cabinet assembly.**

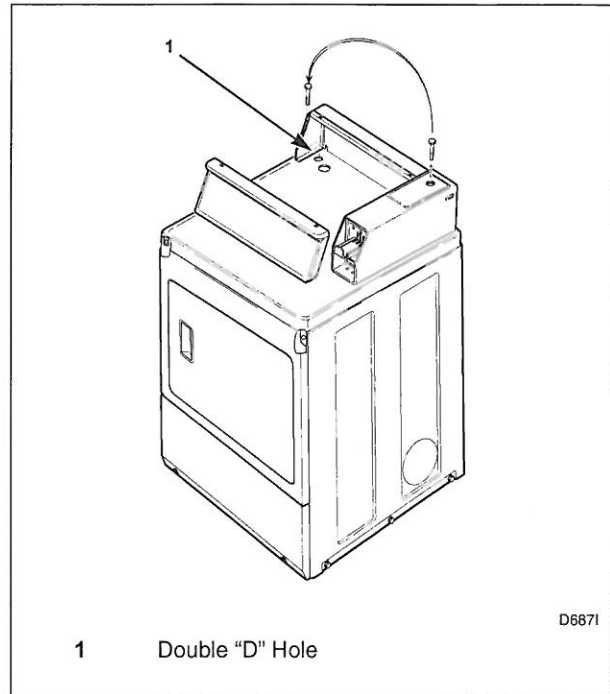

Figure 39

# Operation

## Operation Instructions for Nonmetered and Coin Slide Dryers

**IMPORTANT:** Before using dryer for the first time, use an all-purpose cleaner, or a detergent and water solution, and a damp cloth to remove shipping dust from inside of dryer drum.

**IMPORTANT:** Remove all sharp objects from laundry to avoid tears and rips to items during normal machine operation.

### Step 1: Clean Lint Filter

Clean lint filter before each use.

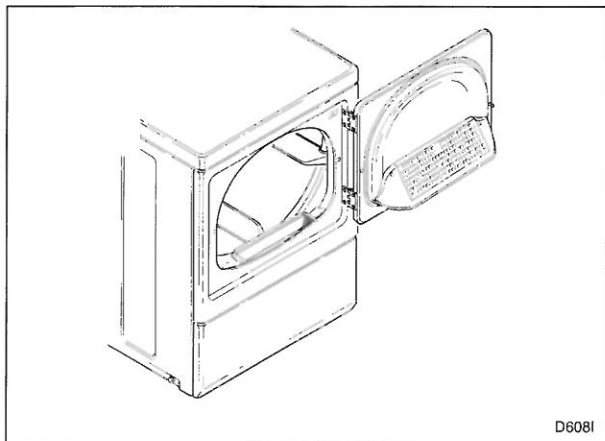

Figure 40

### Step 2: Load Laundry

Load clothes loosely into dryer drum. Add fabric softener sheet if desired.

**IMPORTANT:** To avoid damage to dryer, do not use more than one fabric softener sheet per load.

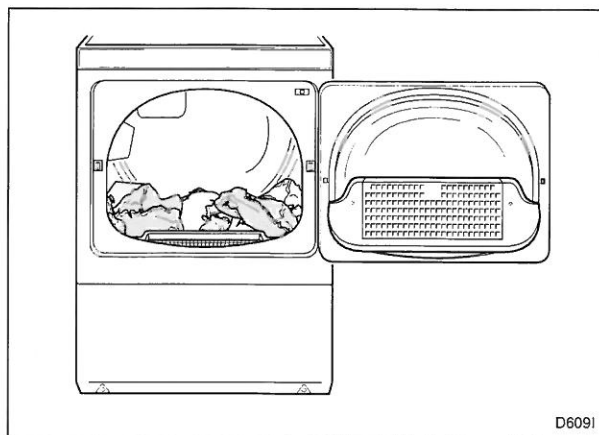

Figure 41

### Step 3: Close Loading Door

Close loading door. Dryer will not operate with the door open.

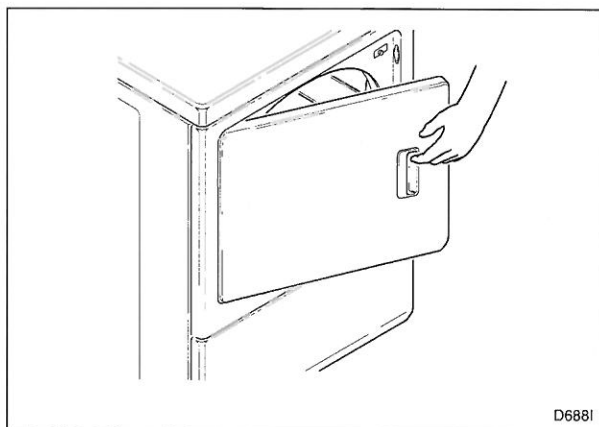

Figure 42

## Operation

### Step 4: Set Fabric Selector

Select **NORMAL** for cottons, **PERM PRESS/CASUAL** for permanent press, **DELICATE** for sensitive items or **FLUFF (NO HEAT)** for items that require no heat.

**NOTE: Always follow manufacturer's care label instructions.**

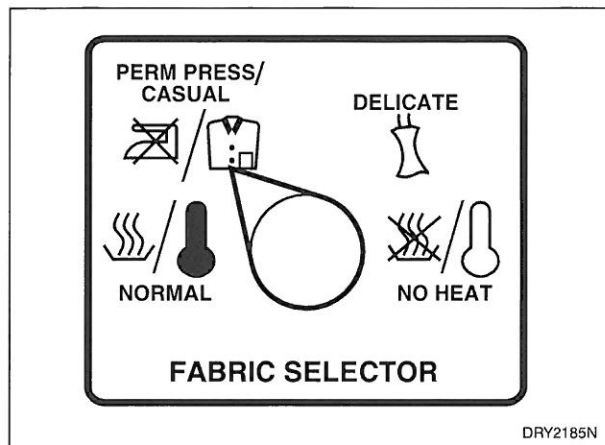

Figure 43

### Step 5: Start Dryer

#### Nonmetered Models

Rotate timer knob to desired time setting (up to 60 minutes). Press the PUSH-TO-START button. *IN USE* light will come on (indicating start of cycle).

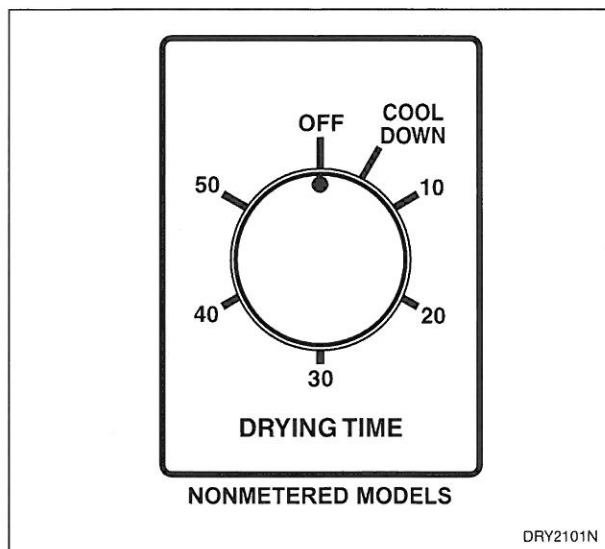

Figure 44

#### Coin Slide Models

Place coin(s) in slide and carefully push in as far as possible and then pull slide out as far as possible. After *IN USE* light comes on (indicating start of cycle), press the PUSH-TO-START button.

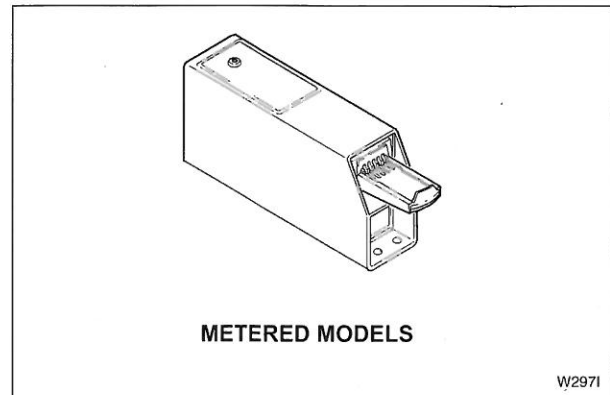

Figure 45

Remove knits when slightly damp because overdrying may cause shrinkage. Do not tumble dry knit woolens.

Should dryer stop before cycle is completed, the motor overload protector may have cycled. Refer to *Maintenance* section.

**NOTE: This machine includes an extended tumble feature. Starting 20 minutes after a cycle ends, the cylinder will tumble for two minutes every hour without heat, up to 18 hours or until door is opened.**

## Operation Instructions for Electronic Display Control Dryers

**IMPORTANT:** Before using dryer for the first time, use an all-purpose cleaner, or a detergent and water solution, and a damp cloth to remove shipping dust from inside of dryer drum.

**IMPORTANT:** Remove all sharp objects from laundry to avoid tears and rips to items during normal machine operation.

### Step 1: Clean Lint Filter

Clean lint filter before each use.

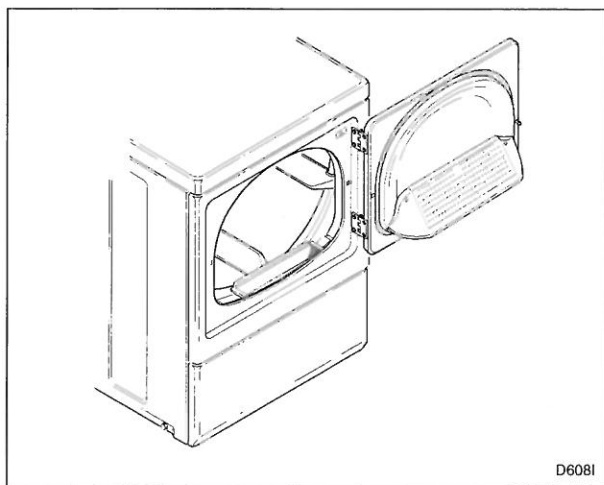

Figure 46

### Step 2: Load Laundry

Load clothes loosely into dryer drum. Add fabric softener sheet if desired.

**IMPORTANT:** To avoid damage to dryer, do not use more than one fabric softener sheet per load.

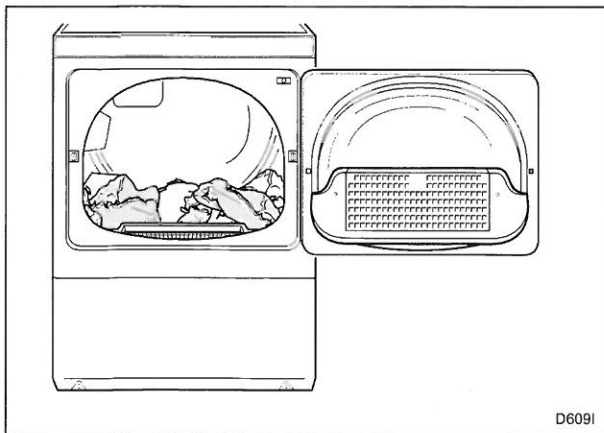

Figure 47

### Step 3: Close Loading Door

Close loading door. Dryer will not operate with the door open.

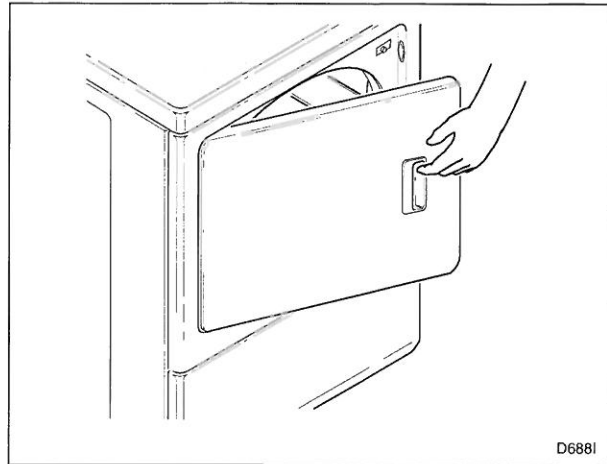

Figure 48

### Step 4: Set Fabric Selector

Select **NORMAL** (High Temp), **PERM PRESS** (Med Temp), **DELICATES** (Low Temp) or **TUMBLE** (No Heat) by pushing touchpad.

**NOTE:** Always follow manufacturer's care label instructions.

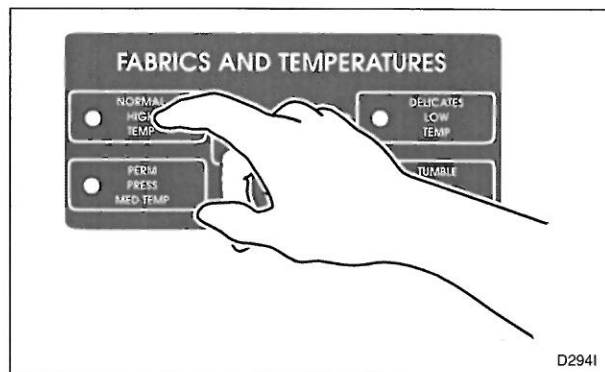

Figure 49

## Operation

### Step 5: Insert Coin(s) or Card

#### To Insert Money

Insert coin(s) in coin slot. Check pricing as seen on digital display.

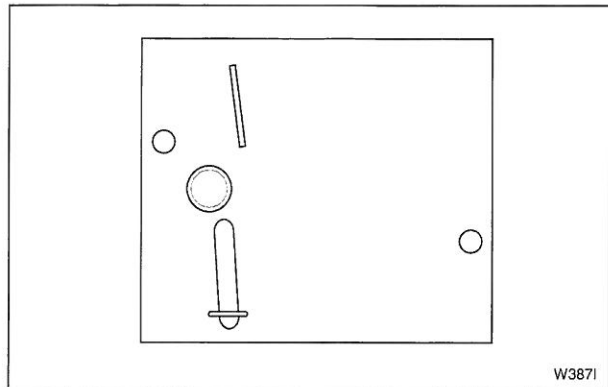

Figure 50

#### To Insert Card

Insert card into opening. Follow directions on display. **DO NOT REMOVE THE CARD UNTIL DISPLAY READS "Remove Card."**

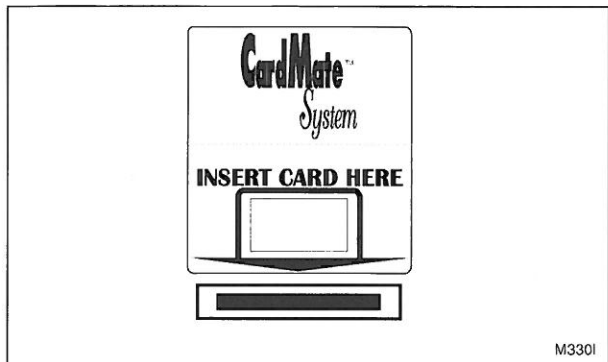

Figure 51

If Additional Time Feature is turned on, additional dryer time may be purchased at cycle start or while dryer is running.

Remove knits when slightly damp because overdrying may cause shrinkage. Do not tumble dry knit woolsens.

### Step 6: Start Dryer

To start dryer, push START pad.

To stop dryer at any time, open the door. To restart the dryer, close door and push START pad.

Cycle is completed when time remaining reaches 00 minutes.

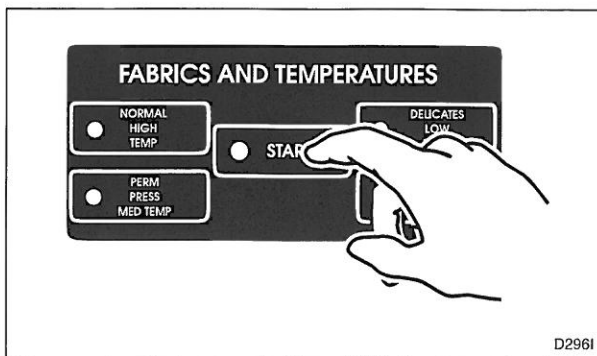

Figure 52

## Indicator Lights

### INSERT COINS

*INSERT COINS* is lit to prompt the user to insert coins or card to satisfy the vend price for the chosen cycle. When *INSERT COINS* is lit, the three digits and decimal point will display the vend price remaining to be satisfied.

### PUSH START

*PUSH START* is lit whenever the dryer is not in a cycle, the full vend price has been satisfied and the dryer door is closed. When the START pad is pressed, the cycle will begin or resume. The *PUSH START* status word flashes at one-second intervals when activated.

**DRYING**

*DRYING* is lit to indicate that one of the heated cycles (HIGH TEMP, MED TEMP, LOW TEMP) is currently in operation. The status word *DRYING* goes off at the end of a heated cycle or when the COOL DOWN cycle begins.

**DOOR OPEN**

*DOOR OPEN* is lit and flashes at one-second intervals whenever the dryer door is open.

**COOL DOWN**

*COOL DOWN* is lit whenever the COOL DOWN portion of a heated cycle is active. It is also lit when the NO HEAT cycle is in operation.

**PRICE**

*PRICE* is lit to indicate that the value displayed is the vend pricing remaining to be satisfied. Once the vend price is satisfied, the word *PRICE* will go off.

**TIME REMAINING**

*TIME REMAINING* is lit to indicate that the time displayed by two digits and the colon is the time remaining (in minutes) in the active cycle. The colon flashes at one-second intervals and time continually counts down in an active cycle.

Should dryer stop before cycle is completed, the motor overload protector may have cycled. Refer to *Maintenance* section.



## Operation

### Operation Instructions for MDC Dryers

**IMPORTANT:** Before using dryer for the first time, use an all-purpose cleaner, or a detergent and water solution, and a damp cloth to remove shipping dust from inside of dryer drum.

**IMPORTANT:** Remove all sharp objects from laundry to avoid tears and rips to items during normal machine operation.

#### Step 1: Clean Lint Filter

Clean lint filter before each use.

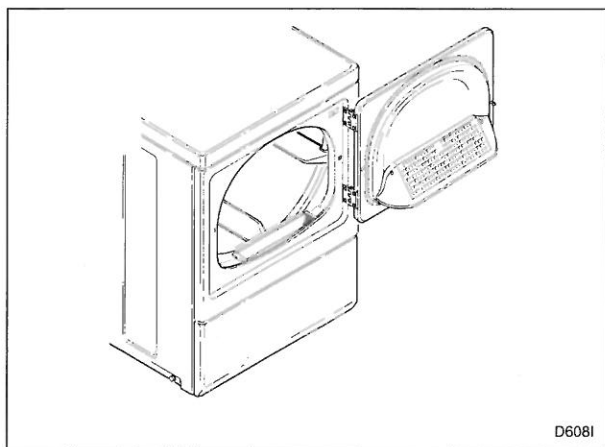

Figure 53

#### Step 2: Load Laundry

Load clothes loosely into dryer drum. Add fabric softener sheet if desired.

**IMPORTANT:** To avoid damage to dryer, do not use more than one fabric softener sheet per load.

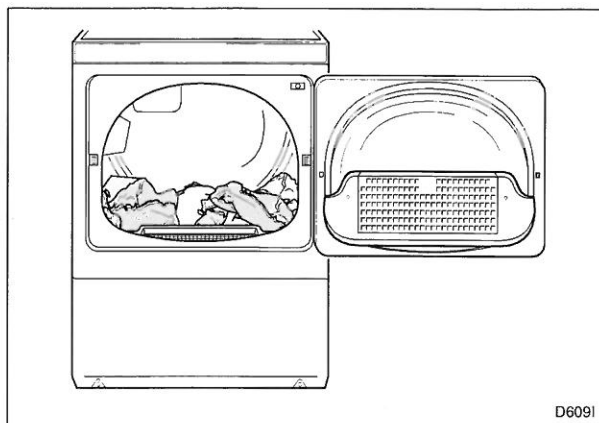

Figure 54

#### Step 3: Close Loading Door

Close loading door. Dryer will not operate with the door open.

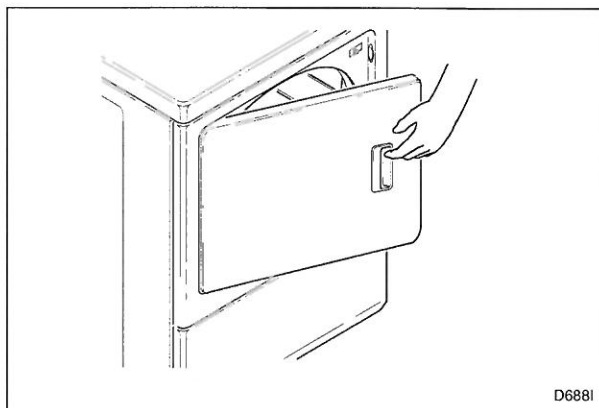

Figure 55

### Step 4: Set Fabric Selector

Select **HIGH TEMP**, **MED TEMP**, **LOW TEMP** or **DELICATES** by pushing touchpad.

**NOTE: Always follow manufacturer's care label instructions.**

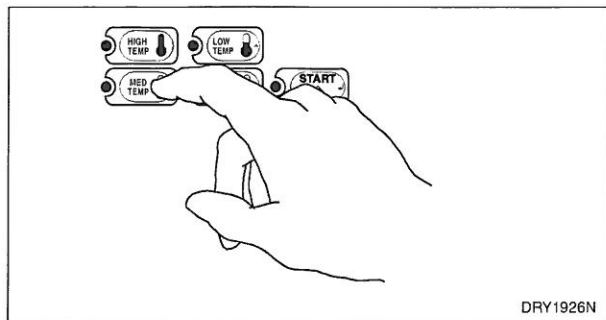

Figure 56

### Step 5: Insert Coin(s) or Card

*To Insert Money*

Insert coin(s) in coin slot. Check pricing as seen on digital display.

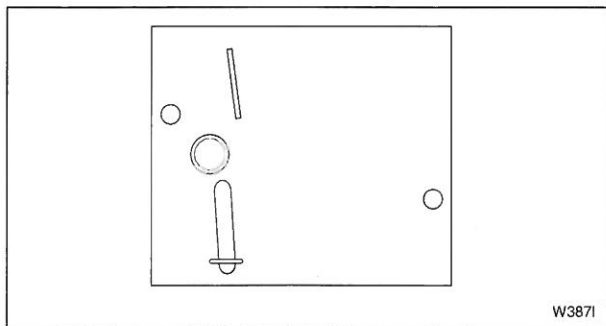

Figure 57

*To Insert Card*

Insert card into opening.

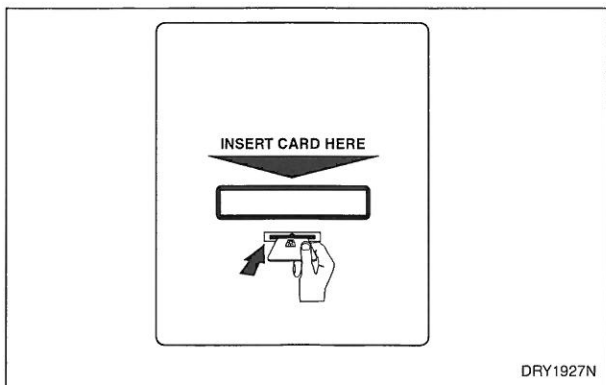

Figure 58

If Additional Time Feature is turned on, additional dryer time may be purchased at cycle start or while dryer is running.

Remove knits when slightly damp because overdrying may cause shrinkage. Do not tumble dry knit woolsens.

### Step 6: Start Dryer

To start dryer, push **START** pad.

To stop dryer at any time, open the door. To restart the dryer, close door and push **START** pad.

Cycle is completed when time remaining reaches 00 minutes.

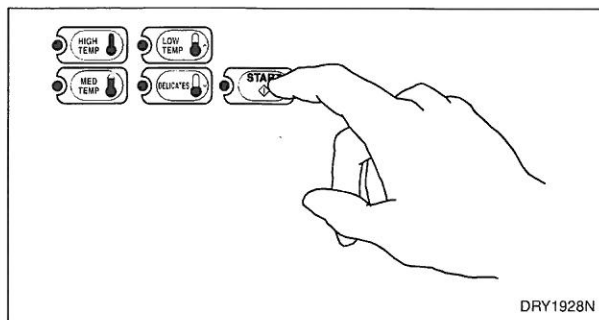

Figure 59

### Indicator Lights

#### START

**START** is lit whenever the dryer is not in a cycle, the full vend price has been satisfied and the dryer door is closed. When the **START** pad is pressed, the cycle will begin or resume.

#### DRYING

**DRYING** is lit to indicate that one of the heated cycles (**HIGH TEMP**, **MED TEMP**, **LOW TEMP** or **DELICATES**) is currently in operation. **DRYING** will turn off at the end of a heated cycle or when the **COOL DOWN** cycle begins.

#### COOL DOWN

**COOL DOWN** is lit whenever the **COOL DOWN** portion of a heated cycle is active. It is also lit when no heat is programmed for a cycle in operation.

## Operation

### Operation Instructions for NetMaster Dryers

**IMPORTANT:** Before using dryer for the first time, use an all-purpose cleaner, or a detergent and water solution, and a damp cloth to remove shipping dust from inside of dryer drum.

**IMPORTANT:** Remove all sharp objects from laundry to avoid tears and rips to items during normal machine operation.

#### Step 1: Clean Lint Filter

Clean lint filter before each use.

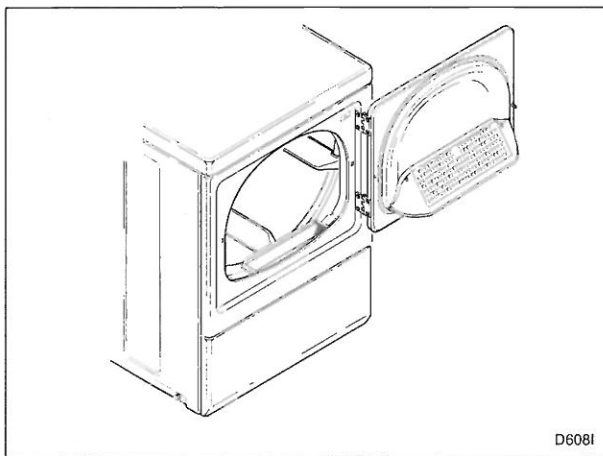

Figure 60

#### Step 2: Load Laundry

Load clothes loosely into dryer drum. Add fabric softener sheet if desired.

**IMPORTANT:** To avoid damage to dryer, do not use more than one fabric softener sheet per load.

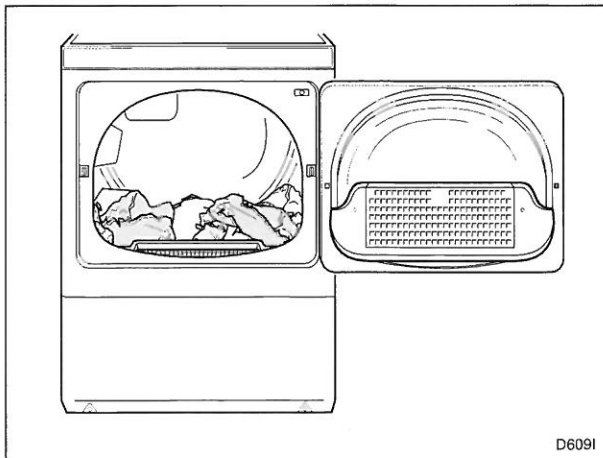

Figure 61

#### Step 3: Close Loading Door

Close loading door. Dryer will not operate with the door open.

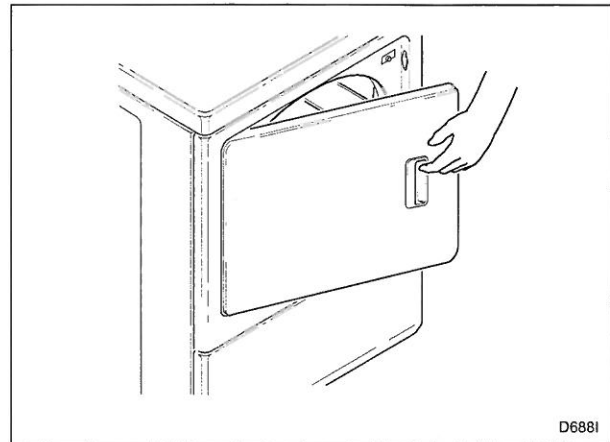

Figure 62

#### Step 4: Set Fabric Selector

Select **HIGH TEMP**, **MED TEMP**, **LOW TEMP** or **NO HEAT** by pushing touchpad.

**NOTE:** Always follow manufacturer's care label instructions.

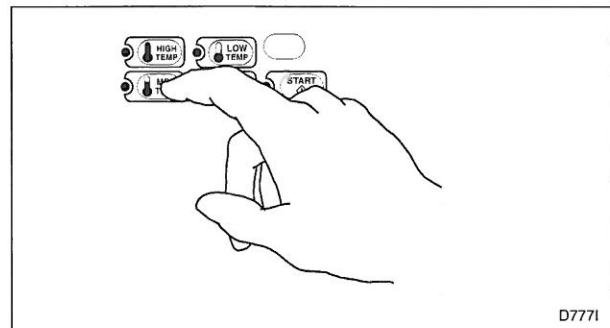

Figure 63

### Step 5: Insert Coin(s) or Card

#### To Insert Money

Insert coin(s) in coin slot. Check pricing as seen on digital display.

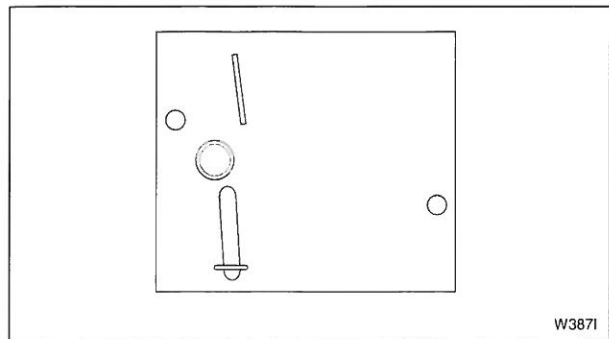

Figure 64

#### To Insert Card

Insert card into opening. Do not remove the card until the *REMOVE CARD* LED is lit.

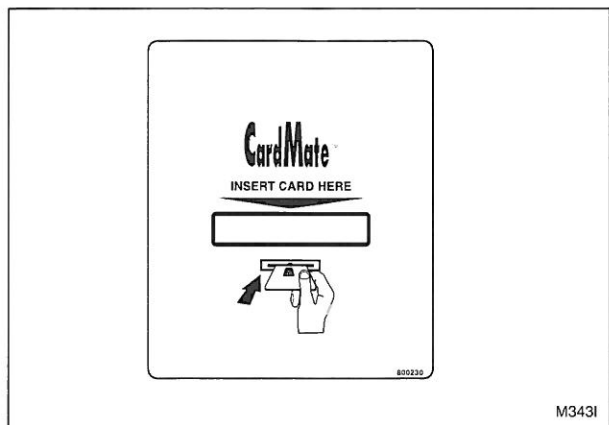

Figure 65

If Additional Time Feature is turned on, additional dryer time may be purchased at cycle start or while dryer is running.

Remove knits when slightly damp because overdrying may cause shrinkage. Do not tumble dry knit woolens.

### Step 6: Start Dryer

To start dryer, push **START** pad.

To stop dryer at any time, open the door. To restart the dryer, close door and push **START** pad.

Cycle is completed when time remaining reaches 00 minutes.

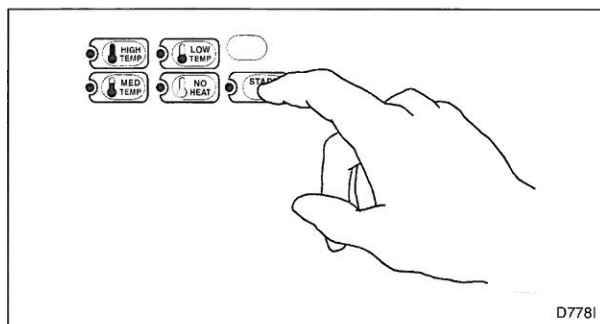

Figure 66

## Operation

### Indicator Lights

#### **INSERT COINS/CARD**

*INSERT COINS/CARD* is lit to prompt the user to insert coins or a card to satisfy the vend price. When *INSERT COINS/CARD* is lit, the three digits and decimal point will display the vend price remaining to be satisfied.

#### **START**

*START* is lit whenever the dryer is not in a cycle, the full vend price has been satisfied and the dryer door is closed. When the **START** pad is pressed, the cycle will begin or resume.

#### **DRYING**

*DRYING* is lit to indicate that one of the heated cycles (HIGH TEMP, MED TEMP, or LOW TEMP) is currently in operation. *DRYING* will turn off at the end of a heated cycle or when the COOL DOWN cycle begins.

#### **COOL DOWN**

*COOL DOWN* is lit whenever the COOL DOWN portion of a heated cycle is active. It is also lit when the NO HEAT cycle is in operation.

#### **ADD TIME (Card Models Only)**

*ADD TIME* flashes when a card is inserted while a cycle is running or when a card is left in the reader for at least five seconds after cycle has started.

#### **REMOVE CARD (Card Models Only)**

*REMOVE CARD* flashes when a card is inserted or left in the reader after a transaction is complete. It will also flash alternately with *ADD TIME* when a card is inserted while a cycle is running or when a card is left in the reader.

# Maintenance

## Lubrication

All moving parts are sealed in a permanent supply of lubricant or are equipped with oilless bearings. Additional lubrication will not be necessary.

## Care of Your Dryer

	<b>WARNING</b>
<b>To reduce the risk of an electric shock, serious injury or death, disconnect the electrical service to the dryer before cleaning the interior.</b>	
W132	

## Dryer Interior

Wipe the surfaces using a soft cloth and household cleaner or a non-abrasive paste of powdered laundry detergent and hot water, followed by a short heat cycle with a load of rags.

To remove crayon or ball point ink off the dryer drum, put the heat on high and use old rags in the dryer to absorb the crayon or ink. If unsuccessful, contact the appliance dealer. **DO NOT** use any chemicals in the dryer.

**IMPORTANT: The use of chlorine bleach for removing any discolorations should be avoided because bleach could damage the finish.**

## Cabinet

Wipe the dryer cabinet as needed. If detergent, bleach or other washing products have been spilled on the dryer, wipe immediately. Some products will cause permanent damage if spilled on the cabinet.

## Control Panel

Use only a damp or sudsy cloth for cleaning the control panel. Some spray pretreat products may harm the finish on the control panel.

**NOTE: The wiring diagram is located inside the control panel.**

	<b>WARNING</b>
<b>Label all wires prior to disconnection when servicing controls. Wiring errors can cause improper and dangerous operation.</b>	
W049	

## Exhaust System

	<b>WARNING</b>
<b>To reduce the risk of electric shock, disconnect the electrical service to the dryer before cleaning.</b>	
W043	

The exhaust duct should be inspected after one year of use and cleaned if necessary by a qualified service person to remove any lint build-up. Inspect and clean exhaust duct every one to two years as required thereafter.

The weather hood should be checked frequently to make sure the dampers move freely, dampers are not pushed in and that nothing has been set against them.

Keep dryer area clear and free from combustible materials, gasoline and other flammable vapors and liquids.

Do not obstruct the flow of combustion and ventilation air.

**NOTE: Verify proper operation after servicing.**

## Maintenance

### Lint Filter

CLEAN THE LINT FILTER BEFORE DRYING EACH LOAD. (Refer to *Figure 67* for lint filter location.) Cleaning the lint filter is important because a layer or pad of lint on the filter will block the flow of air through the dryer, thus reducing the efficiency of the dryer. The clothes will take longer to dry and energy will be wasted.

The lint filter may be washed if needed. Annually remove lint filter and screw to vacuum the duct under it.

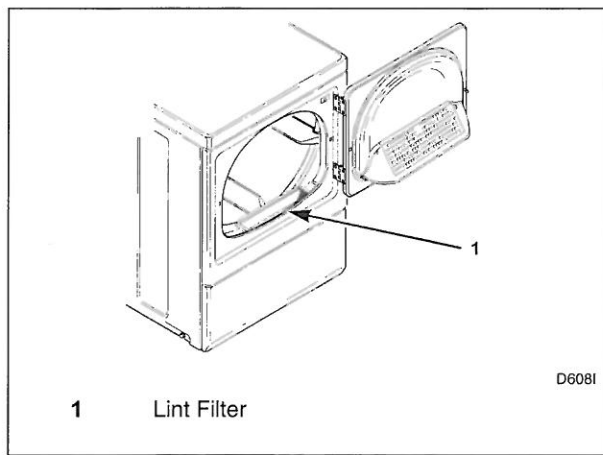

Figure 67

### Motor Overload Protector

The dryer's motor overload protector stops the motor automatically in the event of an overload. After cooling, the overload protector will reset itself. Dryer can be restarted by pressing the PUSH-TO-START button or START pad. If overload protector cycles again, remove the dryer from use and call the service person to correct the problem.

### For Energy Conservation

- Make sure the lint filter is always clean.
- Do not overload dryer.
- Do not overdry clothes.
- Remove items to be ironed while still damp.
- Large loads of similar fabrics dry the most efficiently. However, dry permanent press in smaller loads to prevent wrinkling.
- Use the correct temperature FABRIC SELECTOR setting for the type of fabric being dried.
- Locate your dryer so the exhaust duct is as short and straight as possible.
- Do not open the door during the drying cycle.
- Plan to do your laundry on low humidity days; your clothes will dry faster.
- Should you plan to dry several loads, do them one after another, then you do not have to reheat the dryer unit's interior parts each time.

# Troubleshooting

Try these troubleshooting tips before making a service call. They may save you time and money.

Dryer Symptom	Possible Cause/Solution
<b>Dryer won't start</b>	<ul style="list-style-type: none"> <li>• Nonmetered models - Turn timer knob further into cycle.</li> <li>• Metered models - Insert coin(s) or card.</li> <li>• Metered models - Activate timer. Push coin slide all the way in.</li> <li>• For dryers equipped with a power cord, make sure the power cord is plugged all the way into the electrical outlet.</li> <li>• Make sure loading door is closed.</li> <li>• Press PUSH-TO-START button or START pad.</li> <li>• Make sure the laundry room fuse(s) isn't blown or loose, or circuit breakers aren't open. The dryer itself does not have an electrical fuse. An electric dryer has an electrical circuit with two fuses.</li> <li>• Check if motor overload protector has cycled. Wait 10 minutes and try again.</li> </ul>
<b>Dryer won't heat</b>	<ul style="list-style-type: none"> <li>• Nonmetered models - Turn timer knob further into cycle.</li> <li>• Metered models - Activate timer. Push coin slide all the way in.</li> <li>• Make sure the laundry room fuse(s) isn't blown or loose, or circuit breakers aren't open. The dryer itself does not have an electrical fuse. An electric dryer has an electrical circuit with two fuses.</li> <li>• Make sure controls are in a HEAT setting.</li> <li>• Gas dryer only – Make sure equipment and main gas line valve is turned on.</li> <li>• Check exhaust duct to outside to see if it is kinked, blocked or needs cleaning.</li> <li>• Check weather hood to make sure flapper moves freely, has not been pushed in or has not been blocked.</li> </ul>
<b>Dryer doesn't dry clothes satisfactorily</b>	<ul style="list-style-type: none"> <li>• Check exhaust duct to outside to see if it is kinked, blocked or needs cleaning.</li> <li>• Check weather hood to make sure flapper moves freely, has not been pushed in or has not been blocked.</li> <li>• Clean the lint filter.</li> <li>• Make sure the load isn't too small. Small loads may not tumble properly or dry evenly.</li> <li>• Check load being dried. Heavy items dried with lightweight items will not dry as quickly as the rest of the load.</li> </ul>
<b>Dryer is noisy</b>	<ul style="list-style-type: none"> <li>• Check dryer for foreign objects (nails, coins, bobby pins, metal, plastic toys, etc.). Remove items from dryer.</li> <li>• Make sure dryer is level. Uneven leveling can cause vibration.</li> <li>• Normal operating sounds include the tick of timer advancing, heat source going on and off, and humming of air moving through the dryer and exhaust system.</li> </ul>
<b>Clothes are too wrinkled</b>	<ul style="list-style-type: none"> <li>• Check heat setting. Overdrying can cause wrinkling.</li> <li>• Check load size. Large loads may not tumble properly and may cause wrinkling.</li> </ul>
<b>Clothes have odor</b>	<ul style="list-style-type: none"> <li>• Check room for odors before drying clothes. Any odor (fried foods, paint, varnish, cleaners, burning wood, etc.) will transfer to clothing as the dryer draws air from the room. Ventilate room before drying clothes.</li> </ul>



# Contact Information

If service is required, contact the nearest Factory Authorized Service Center.

If you are unable to locate an authorized service center or are unsatisfied with the service performed on your dryer, contact:

**Alliance Laundry Systems**  
Shepard Street  
P. O. Box 990  
Ripon, WI 54971-0990  
U.S.A.  
[www.comlaundry.com](http://www.comlaundry.com)  
Phone: (920) 748-3121

Date Purchased \_\_\_\_\_

Model Number \_\_\_\_\_

Serial Number \_\_\_\_\_

When calling or writing about your dryer, **PLEASE GIVE THE MODEL AND SERIAL NUMBERS.** The model and serial numbers are located on the nameplate. The nameplate will be in the location shown in the illustration below. Please include a copy of your bill of sale and any service receipts you have.

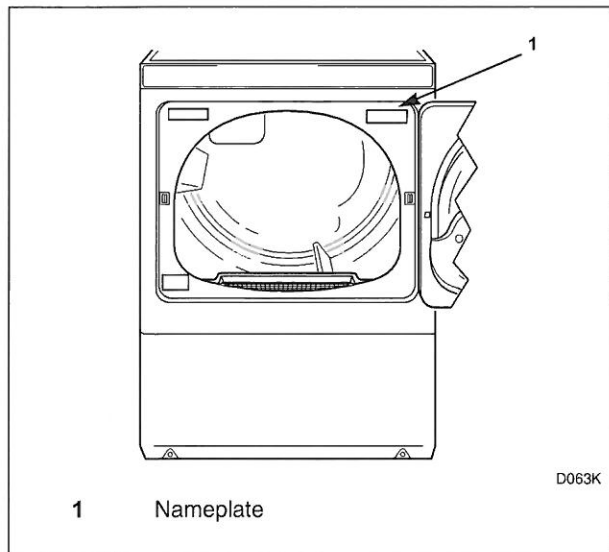

Figure 68

	<b>WARNING</b>
<p><b>To reduce the risk of serious injury or death, DO NOT repair or replace any part of the dryer or attempt any servicing unless specifically recommended in the user-maintenance instructions or in published user-repair instructions that you understand and have the skills to carry out.</b></p>	
<small>W133</small>	

If replacement parts are required, contact the source from which you purchased your dryer or contact us at (920) 748-3950 for the name and address of the nearest authorized parts distributor.

# Installer Checklist

## Fast Track for Installing the Dryer

(Refer to the manual for more detailed information)

**1** • Position and Level the Dryer.

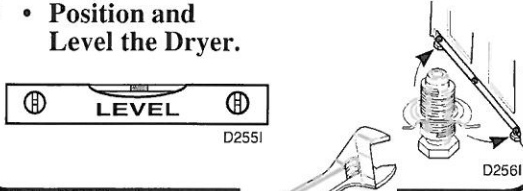

A diagram showing a level (D2551) being used to check the dryer's level. A wrench (D2591) is used to adjust the leveling legs (D2561).

CHECK

**6** • Wipe Out Inside of Dryer.

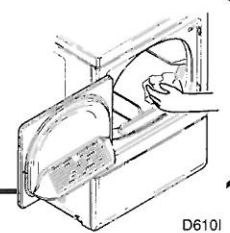

A diagram showing a hand wiping the inside of the dryer drum (D610).

CHECK

**2** • Connect Dryer Exhaust System.

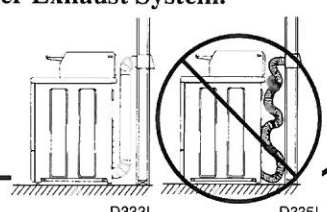

A diagram showing the dryer (D3331) connected to an exhaust duct (D3351).

CHECK

**7** • Plug In the Dryer.

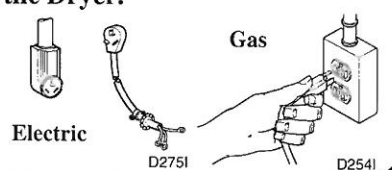

A diagram showing the dryer being plugged into an electrical outlet (D2541) for electric (D2751) or gas power.

CHECK

**3** **GAS ONLY**

- Connect Gas Supply Pipe Hoses.
- Check for Gas Leaks.

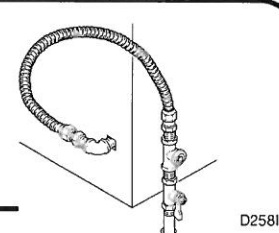

A diagram showing gas supply pipe hoses (D2581) being connected to the dryer.

CHECK

**8** • Recheck Steps 1-7.

CHECK

**4** **ELECTRIC ONLY**

- Connect Electrical Cord.

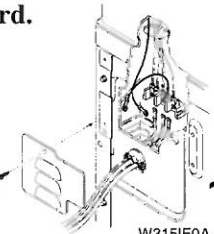

A diagram showing an electrical cord being connected to the dryer (W3151E0A).

CHECK

**9** • Check Heat Source.

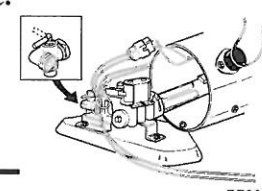

A diagram showing the heat source being checked (D7001).

CHECK

**5** • Reverse Door, if Desired.

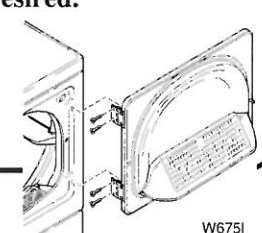

A diagram showing the dryer door (W6751) being reversed.

CHECK



## COMMERCIAL SMALL LOAD LAUNDRY EQUIPMENT

### LIMITED WARRANTY—ECON-O-WASH AND ECON-O-DRY MODELS

Effective December 2006 (Starting Serial Number by Model Available Upon Request)



#### I. What this Limited Warranty Covers and For How Long

Continental Girbau, Inc. (Continental), Oshkosh, WI 54904 extends this limited warranty to the original owner (Purchaser), or by factory authorized warranty transfer to a new owner, of a Continental Girbau Econ-O-Wash topload washer or Econ-O-Dry singleload or stacked drying tumbler (Equipment).

Continental will repair or replace, free of charge, any part which fails as a result of a defect in material or workmanship for a period of three years (36 months) after the date of original installation. Additionally, Continental will repair or replace, free of charge, the following items if failure as a result of a defect in material or workmanship occurs:

- Econ-O-Wash washer transmission assembly for a period of five years (60 months) after installation
- Econ-O-Wash and Econ-O-Dry base assembly and cabinet assembly (including top, lid, and door) against rust from the inside out for a period of five years (60 months) after installation
- Econ-O-Wash stainless steel wash tub for the life of the washer

If the date of installation of the Equipment cannot be definitely determined, the date of installation shall be deemed to be 90 days after the date of sale by Continental to the Purchaser.

#### II. What this Limited Warranty Does Not Cover

Continental will not provide a replacement of any part which fails for reasons other than defective material or workmanship. This includes, but is not limited to, failure as a result of abuse, misuse, improper installation and transportation damage.

Continental will not honor this warranty for parts which have been altered without the written consent of Continental's President or if parts have been altered in any way, so as in the judgement of Continental, to adversely affect the stability or reliability of the Equipment or parts.

Continental will not honor this warranty if parts from a manufacturer other than Continental have been incorporated on the equipment or if parts have been incorporated which have not been purchased from Continental.

Continental will not pay labor and transportation charges incurred in the replacement of any part.

Continental is not responsible for clothing or machine damage caused by foreign objects placed in unit.

Continental is not responsible for any consequential damage resulting from any malfunction.

Continental is not be responsible for, and rejects liability for, any part failure if such failure is due to an act of God, natural disaster, vandalism, intentional infliction of damage or dereliction.

Continental is not be responsible for freight or transportation costs of any part covered under the terms of the product warranty.

Continental is not responsible for damage resulting from worn or cracked washer hoses.

#### III. How to Obtain Replacement Parts Under this Limited Warranty

For warranty service, Purchaser shall contact the distributor from which the equipment or part was originally purchased or the nearest Continental distributor. In the event that the Purchaser is unable to make contact with a Continental distributor, the Purchaser shall contact Continental directly. Proof of purchase, model number, serial number and the defective part (part return-USA only) are required in order to obtain credit.

Important: Outside the USA this limited warranty may not be applicable. Consult your authorized Continental Girbau distributor or route operator regarding the applicability, if any, of warranty coverage to you.

THIS WARRANTY IS EXPRESSLY IN LIEU OF ALL OTHER WARRANTIES EXPRESS OR IMPLIED, INCLUDING THE WARRANTIES OF MERCHANTABILITY AND FITNESS FOR USE AND ALL OTHER OBLIGATIONS OR LIABILITIES ON CONTINENTAL'S PART. CONTINENTAL NEITHER ASSUMES NOR AUTHORIZES ANY OTHER PERSON TO ASSUME FOR CONTINENTAL ANY OTHER LIABILITY IN CONNECTION WITH THE SALE OF THE EQUIPMENT AND PARTS. THIS LIMITED WARRANTY IS EXCLUSIVE AND IN LIEU OF ALL OTHER WARRANTIES AND PURCHASER HEREBY WAIVES ALL OTHER REMEDIES, WARRANTIES, GUARANTEES OR LIABILITIES, EXPRESS OR IMPLIED, ARISING BY LAW OR OTHERWISE (INCLUDING WITHOUT LIMITATION ANY OBLIGATIONS OF CONTINENTAL WITH RESPECT TO FITNESS, MERCHANTABILITY, INCIDENTAL DAMAGES AND CONSEQUENTIAL DAMAGES) OR WHETHER OR NOT OCCASIONED BY CONTINENTAL'S NEGLIGENCE. THIS WARRANTY SHALL NOT BE EXTENDED, ALTERED OR VARIED EXCEPT UPON THE PRIOR WRITTEN INSTRUMENT SIGNED BY CONTINENTAL GIRBAU INC.'S PRESIDENT.

STATE OF WEST VIRGINIA  
Purchasing Division

# PURCHASING AFFIDAVIT

**CONSTRUCTION CONTRACTS:** Under W. Va. Code § 5-22-1(i), the contracting public entity shall not award a construction contract to any bidder that is known to be in default on any monetary obligation owed to the state or a political subdivision of the state, including, but not limited to, obligations related to payroll taxes, property taxes, sales and use taxes, fire service fees, or other fines or fees.

**ALL OTHER CONTRACTS:** Under W. Va. Code §5A-3-10a, no contract or renewal of any contract may be awarded by the state or any of its political subdivisions to any vendor or prospective vendor when the vendor or prospective vendor or a related party to the vendor or prospective vendor is a debtor and: (1) the debt owed is an amount greater than one thousand dollars in the aggregate; or (2) the debtor is in employer default.

**EXCEPTION:** The prohibition listed above does not apply where a vendor has contested any tax administered pursuant to chapter eleven of the W. Va. Code, workers' compensation premium, permit fee or environmental fee or assessment and the matter has not become final or where the vendor has entered into a payment plan or agreement and the vendor is not in default of any of the provisions of such plan or agreement.

**DEFINITIONS:**

**"Debt"** means any assessment, premium, penalty, fine, tax or other amount of money owed to the state or any of its political subdivisions because of a judgment, fine, permit violation, license assessment, defaulted workers' compensation premium, penalty or other assessment presently delinquent or due and required to be paid to the state or any of its political subdivisions, including any interest or additional penalties accrued thereon.

**"Employer default"** means having an outstanding balance or liability to the old fund or to the uninsured employers' fund or being in policy default, as defined in W. Va. Code § 23-2c-2, failure to maintain mandatory workers' compensation coverage, or failure to fully meet its obligations as a workers' compensation self-insured employer. An employer is not in employer default if it has entered into a repayment agreement with the Insurance Commissioner and remains in compliance with the obligations under the repayment agreement.

**"Related party"** means a party, whether an individual, corporation, partnership, association, limited liability company or any other form or business association or other entity whatsoever, related to any vendor by blood, marriage, ownership or contract through which the party has a relationship of ownership or other interest with the vendor so that the party will actually or by effect receive or control a portion of the benefit, profit or other consideration from performance of a vendor contract with the party receiving an amount that meets or exceeds five percent of the total contract amount.

**AFFIRMATION:** By signing this form, the vendor's authorized signer affirms and acknowledges under penalty of law for false swearing (W. Va. Code §61-5-3) that: (1) for construction contracts, the vendor is not in default on any monetary obligation owed to the state or a political subdivision of the state, and (2) for all other contracts, that neither vendor nor any related party owe a debt as defined above and that neither vendor nor any related party are in employer default as defined above, unless the debt or employer default is permitted under the exception above.

**WITNESS THE FOLLOWING SIGNATURE:**

Vendor's Name: Advantage Equipment INC.

Authorized Signature: [Signature] Date: 11/10/17

State of Ohio

County of Summit, to-wit:

Taken, subscribed, and sworn to before me this 10 day of NOVEMBER, 2017.

My Commission expires \_\_\_\_\_, 20\_\_\_\_.

AFFIX SEAL HERE



Debra L. Wickiser  
Resident Summit County  
Notary Public, State of Ohio  
NOTARY PUBLIC [Signature]  
My Commission Expires: 3/7/2022

## State of West Virginia

# VENDOR PREFERENCE CERTIFICATE

Certification and application\* is hereby made for Preference in accordance with *West Virginia Code*, §5A-3-37. (Does not apply to construction contracts). *West Virginia Code*, §5A-3-37, provides an opportunity for qualifying vendors to request (at the time of bid) preference for their residency status. Such preference is an evaluation method only and will be applied only to the cost bid in accordance with the *West Virginia Code*. This certificate for application is to be used to request such preference. The Purchasing Division will make the determination of the Vendor Preference, if applicable.

1. **Application is made for 2.5% vendor preference for the reason checked:**  
 Bidder is an individual resident vendor and has resided continuously in West Virginia for four (4) years immediately preceding the date of this certification; **or**,  
 Bidder is a partnership, association or corporation resident vendor and has maintained its headquarters or principal place of business continuously in West Virginia for four (4) years immediately preceding the date of this certification; or 80% of the ownership interest of Bidder is held by another individual, partnership, association or corporation resident vendor who has maintained its headquarters or principal place of business continuously in West Virginia for four (4) years immediately preceding the date of this certification; **or**,  
 Bidder is a nonresident vendor which has an affiliate or subsidiary which employs a minimum of one hundred state residents and which has maintained its headquarters or principal place of business within West Virginia continuously for the four (4) years immediately preceding the date of this certification; **or**,
2. **Application is made for 2.5% vendor preference for the reason checked:**  
 Bidder is a resident vendor who certifies that, during the life of the contract, on average at least 75% of the employees working on the project being bid are residents of West Virginia who have resided in the state continuously for the two years immediately preceding submission of this bid; **or**,
3. **Application is made for 2.5% vendor preference for the reason checked:**  
 Bidder is a nonresident vendor employing a minimum of one hundred state residents or is a nonresident vendor with an affiliate or subsidiary which maintains its headquarters or principal place of business within West Virginia employing a minimum of one hundred state residents who certifies that, during the life of the contract, on average at least 75% of the employees or Bidder's affiliate's or subsidiary's employees are residents of West Virginia who have resided in the state continuously for the two years immediately preceding submission of this bid; **or**,
4. **Application is made for 5% vendor preference for the reason checked:**  
 Bidder meets either the requirement of both subdivisions (1) and (2) or subdivision (1) and (3) as stated above; **or**,
5. **Application is made for 3.5% vendor preference who is a veteran for the reason checked:**  
 Bidder is an individual resident vendor who is a veteran of the United States armed forces, the reserves or the National Guard and has resided in West Virginia continuously for the four years immediately preceding the date on which the bid is submitted; **or**,
6. **Application is made for 3.5% vendor preference who is a veteran for the reason checked:**  
 Bidder is a resident vendor who is a veteran of the United States armed forces, the reserves or the National Guard, if, for purposes of producing or distributing the commodities or completing the project which is the subject of the vendor's bid and continuously over the entire term of the project, on average at least seventy-five percent of the vendor's employees are residents of West Virginia who have resided in the state continuously for the two immediately preceding years.
7. **Application is made for preference as a non-resident small, women- and minority-owned business, in accordance with *West Virginia Code* §5A-3-59 and *West Virginia Code of State Rules*.**  
 Bidder has been or expects to be approved prior to contract award by the Purchasing Division as a certified small, women- and minority-owned business.

Bidder understands if the Secretary of Revenue determines that a Bidder receiving preference has failed to continue to meet the requirements for such preference, the Secretary may order the Director of Purchasing to: (a) reject the bid; or (b) assess a penalty against such Bidder in an amount not to exceed 5% of the bid amount and that such penalty will be paid to the contracting agency or deducted from any unpaid balance on the contract or purchase order.

By submission of this certificate, Bidder agrees to disclose any reasonably requested information to the Purchasing Division and authorizes the Department of Revenue to disclose to the Director of Purchasing appropriate information verifying that Bidder has paid the required business taxes, provided that such information does not contain the amounts of taxes paid nor any other information deemed by the Tax Commissioner to be confidential.

Under penalty of law for false swearing (*West Virginia Code*, §61-5-3), Bidder hereby certifies that this certificate is true and accurate in all respects; and that if a contract is issued to Bidder and if anything contained within this certificate changes during the term of the contract, Bidder will notify the Purchasing Division in writing immediately.

Bidder: ADVANTAGE Equipment Inc Signed: [Signature]

Date: 11/10/17 Title: \_\_\_\_\_

West Virginia Ethics Commission  
**Disclosure of Interested Parties to Contracts**

(Required by W. Va. Code § 6D-1-2)

Contracting Business Entity: Advanced Equipment Inc Address: 1056 Howe Ave  
Ashland, Ohio 44810

Authorized Agent: Scott Vlahos Address: same

Contract Number: CON 1800000008 Contract Description: DRYERS - ELECTRIC

Governmental agency awarding contract: WEST VIRGINIA DIVISION OF CONTRACTS

Check here if this is a Supplemental Disclosure

List the Names of Interested Parties to the contract which are known or reasonably anticipated by the contracting business entity for each category below (attach additional pages if necessary):

1. Subcontractors or other entities performing work or service under the Contract

Check here if none, otherwise list entity/individual names below.

2. Any person or entity who owns 25% or more of contracting entity (not applicable to publicly traded entities)

Check here if none, otherwise list entity/individual names below.

3. Any person or entity that facilitated, or negotiated the terms of, the applicable contract (excluding legal services related to the negotiation or drafting of the applicable contract)

Check here if none, otherwise list entity/individual names below.

Signature: [Signature] Date Signed: 11/10/17

**Notary Verification**

State of Ohio, County of Summit:

I, Scott Vlahos, the authorized agent of the contracting business entity listed above, being duly sworn, acknowledge that the Disclosure herein is being made under oath and under the penalty of perjury.

Taken, sworn to and subscribed before me this 10<sup>th</sup> day of November

[Signature]  
Notary Public's Signature

**To be completed by State Agency:**

Date Received by State Agency: \_\_\_\_\_

Date submitted to Ethics Commission: \_\_\_\_\_

Governmental agency submitting Disclosure: \_\_\_\_\_



Debra L. Wickiser  
Resident Summit County  
Notary Public, State of Ohio  
My Commission Expires: 3/7/2022

EXHIBIT A	CRFQ COR1800000008			
CONTRACT ITEM NO.	DESCRIPTION	QTY	UNIT PRICE	TOTAL
Item No. 3.1.1	Commercial Electric Clothes Dryer Manufacturer Bid: Model No. Bid:	29	\$ 874 <sup>-</sup>	\$ 25,346. <sup>00</sup>
**Unit prices to be inclusive of all freight/delivery costs** Failure to use this form may result in disqualification				

Bidder / Vendor Information:	
Name:	ADVANTAGE Equipment, INC.
Address:	1056 Home Ave Arkham OHIO 44310
Phone:	330 475 8220
Fax:	330 475 8218
E-mail Address:	Sylvia@advantageequipment.com
Authorized Signature:	
Date:	11/10/11

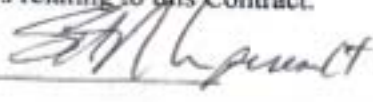

**DESIGNATED CONTACT:** Vendor appoints the individual identified in this Section as the Contract Administrator and the initial point of contact for matters relating to this Contract.

Scott Vlahos, President 

(Name, Title)

Scott Vlahos President

(Printed Name and Title)

1056 HOME AVE.

(Address)

330-475-8220 FAX 330-475-8218

(Phone Number) / (Fax Number)

SVLAHOS@ADVANTAGEEQUIPMENT.NET

(email address)

**CERTIFICATION AND SIGNATURE:** By signing below, or submitting documentation through wvOASIS, I certify that I have reviewed this Solicitation in its entirety; that I understand the requirements, terms and conditions, and other information contained herein; that this bid, offer or proposal constitutes an offer to the State that cannot be unilaterally withdrawn; that the product or service proposed meets the mandatory requirements contained in the Solicitation for that product or service, unless otherwise stated herein; that the Vendor accepts the terms and conditions contained in the Solicitation, unless otherwise stated herein; that I am submitting this bid, offer or proposal for review and consideration; that I am authorized by the vendor to execute and submit this bid, offer, or proposal, or any documents related thereto on vendor's behalf; that I am authorized to bind the vendor in a contractual relationship; and that to the best of my knowledge, the vendor has properly registered with any State agency that may require registration.

Advantage Equipment INC

(Company)

 President

(Authorized Signature) (Representative Name, Title)

Scott Vlahos President

(Printed Name and Title of Authorized Representative)

11/10/17

(Date)

330-475-8220 x101 330-475-8218

(Phone Number) (Fax Number)

ADDENDUM ACKNOWLEDGEMENT FORM  
SOLICITATION NO.: CRFQ COR1800000008

Instructions: Please acknowledge receipt of all addenda issued with this solicitation by completing this addendum acknowledgment form. Check the box next to each addendum received and sign below. Failure to acknowledge addenda may result in bid disqualification.

Acknowledgment: I hereby acknowledge receipt of the following addenda and have made the necessary revisions to my proposal, plans and/or specification, etc.

Addendum Numbers Received:  
(Check the box next to each addendum received)

- |  |  |
|--|--|
| <input checked="" type="checkbox"/> Addendum No. 1 | <input type="checkbox"/> Addendum No. 6  |
| <input type="checkbox"/> Addendum No. 2            | <input type="checkbox"/> Addendum No. 7  |
| <input type="checkbox"/> Addendum No. 3            | <input type="checkbox"/> Addendum No. 8  |
| <input type="checkbox"/> Addendum No. 4            | <input type="checkbox"/> Addendum No. 9  |
| <input type="checkbox"/> Addendum No. 5            | <input type="checkbox"/> Addendum No. 10 |

I understand that failure to confirm the receipt of addenda may be cause for rejection of this bid. I further understand that any verbal representation made or assumed to be made during any oral discussion held between Vendor's representatives and any state personnel is not binding. Only the information issued in writing and added to the specifications by an official addendum is binding.

Company Advanced Equipment LLC

Authorized Signature [Signature]

Date 11/10/17

NOTE: This addendum acknowledgement should be submitted with the bid to expedite document processing.