



# West Virginia Purchasing Division

2019 Washington Street, East  
Charleston, WV 25305  
Telephone: 304-558-2306  
General Fax: 304-558-6026  
Bid Fax: 304-558-3970

The following documentation is an electronically-submitted vendor response to an advertised solicitation from the *West Virginia Purchasing Bulletin* within the Vendor Self-Service portal at ***wvOASIS.gov***. As part of the State of West Virginia's procurement process, and to maintain the transparency of the bid-opening process, this documentation submitted online is publicly posted by the West Virginia Purchasing Division at ***WVPurchasing.gov*** with any other vendor responses to this solicitation submitted to the Purchasing Division in hard copy format.

## Header @ 2

List View

### General Information | Contact | Default Values | Discount | Document Information

Procurement Folder: 266603

SO Doc Code: CRFQ

Procurement Type: Central Purchase Order

SO Dept: 1400

Vendor ID: VS0000011391

SO Doc ID: AGR1700000006

Legal Name: McPherson Systems Inc.

Published Date: 10/24/16

Alias/DBA:

Close Date: 11/17/16

Total Bid: \$38,850.00

Close Time: 13:30

Response Date: 11/17/2016

Status: Closed

Response Time: 12:06

Solicitation Description: Trench/Air Curtain Burner

Total of Header Attachments: 2

Total of All Attachments: 2



Purchasing Division  
 2019 Washington Street East  
 Post Office Box 50130  
 Charleston, WV 25305-0130

State of West Virginia  
 Solicitation Response

Proc Folder : 266603  
 Solicitation Description : Trench/Air Curtain Burner  
 Proc Type : Central Purchase Order

Date issued	Solicitation Closes	Solicitation Response	Version
	2016-11-17 13:30:00	SR 1400 ESR11171600000002274	1

VENDOR
VS0000011391 McPherson Systems Inc.

Solicitation Number: CRFQ 1400 AGR1700000006

Total Bid : \$38,850.00      Response Date: 2016-11-17      Response Time: 12:06:25

Comments: See attached pdf files for bid exceptions and comments. Machine delivery is 6-8 weeks after receipt of purchase order.  
 Dan McPherson  
 McPherson Systems Inc.  
 Tifton, GA  
 (229) 386-2367 office

**FOR INFORMATION CONTACT THE BUYER**  
 Linda Harper  
 (304) 558-0468  
 linda.b.harper@wv.gov

Signature on File	FEIN #	DATE
-------------------	--------	------

All offers subject to all terms and conditions contained in this solicitation

Line	Comm Ln Desc	Qty	Unit Issue	Unit Price	Ln Total Or Contract Amount
1	Trench/Air Curtain Burner	1.00000	EA	\$36,900.000000	\$36,900.00

Comm Code	Manufacturer	Specification	Model #
41102401			

<b>Extended Description :</b>	Trench/Air Curtain Burner per Section 3.1.1
-------------------------------	---

**Comments:** See attached files for bid exceptions and comments. Delivery is 6-8 weeks after receipt of purchase order.

Line	Comm Ln Desc	Qty	Unit Issue	Unit Price	Ln Total Or Contract Amount
2	Freight	1.00000	EA	\$1,950.000000	\$1,950.00

Comm Code	Manufacturer	Specification	Model #
78121603			

<b>Extended Description :</b>	Freight per section 6.1
-------------------------------	-------------------------

## **Specifications for M30F Air Curtain Destructor**

### **A. Blower Unit**

Diesel power, **99hp 4.4L Perkins Tier 3 engine** with 11 1/2" PTO clutch and safety shutdowns on oil pressure and water temperature. Unit has **105 gallon fuel tank**.

Vane Axial Fan - **37 inch, 8 blade steel**, computer balanced

- Volume - 50,000 cubic ft. per minute at atmospheric pressure.
- Fan Housing -11 gage double steel for noise suppression and safety
- Air volume minimum of 25,000 ft.<sup>3</sup>/min. at nozzle.

Plenum section - 12 gage steel construction with self-sealing fireproof connection to the nozzle

### **B. Nozzle**

Nozzle section - 11 gage steel with **no bolt-together sections** with reinforcement at air outlets. Nozzle attaches to plenum using a **patented quick hitch system**. **30' nozzle length**

Nozzle velocity - 8000 ft./min. - minimum

### **C. Setup and Transport**

Air curtain is completely portable and can be set up for transport or use in 15 minutes. Unit has two axles (one with electric brakes) and trailer lights. Axles are 6 lug.

### **D. Warranty**

Warranty - The machine in total is warranted for a period of one year for defects in parts or workmanship. Non warranty items are belts, tires, or damage from misuse or abuse of the machine.



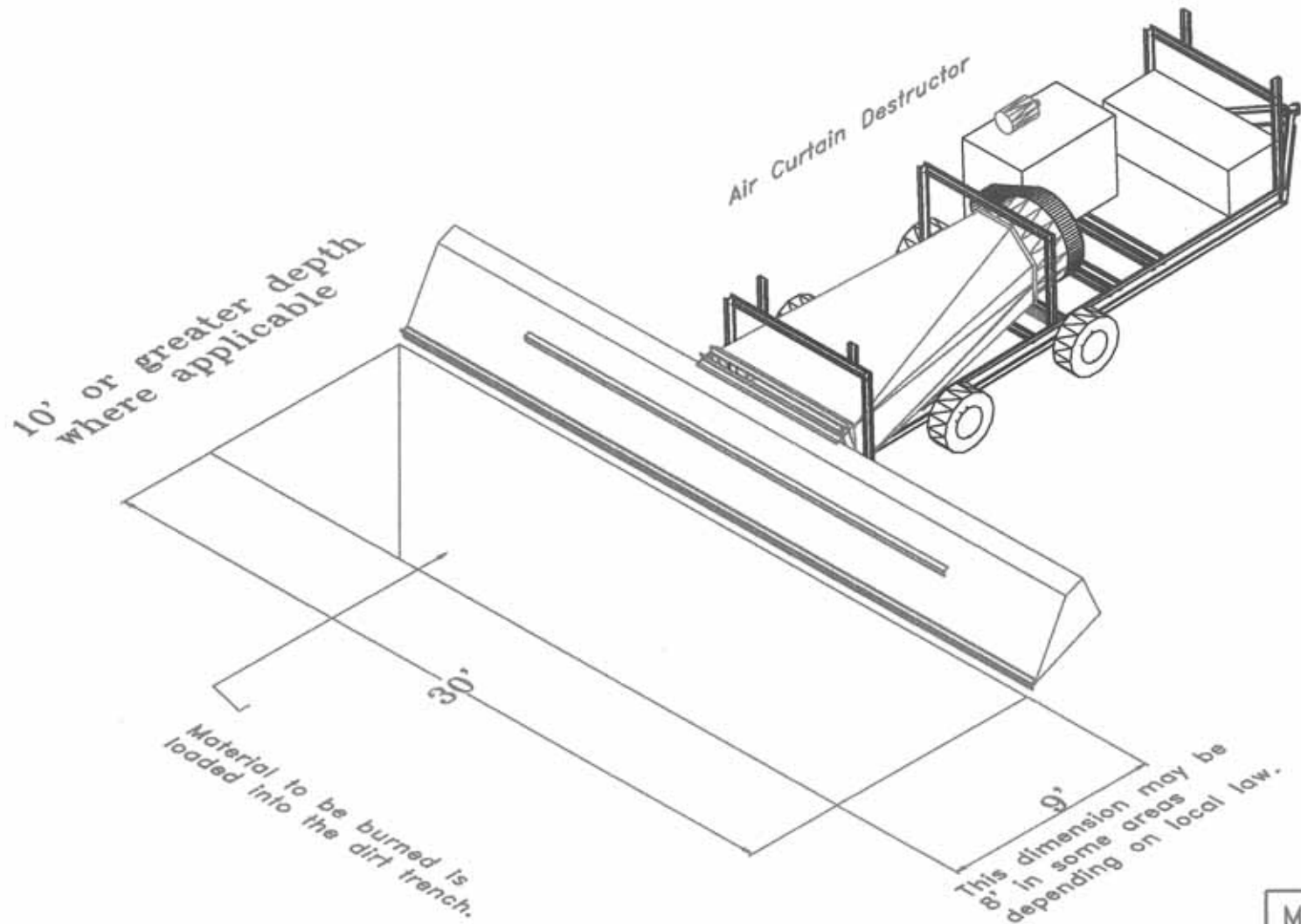

McPherson Systems Inc.
Tifton, GA
(229) 386-2367
M30F Set-up diagram

Notes:  
Machine weight with nozzle  
is approximately 7500 pounds.

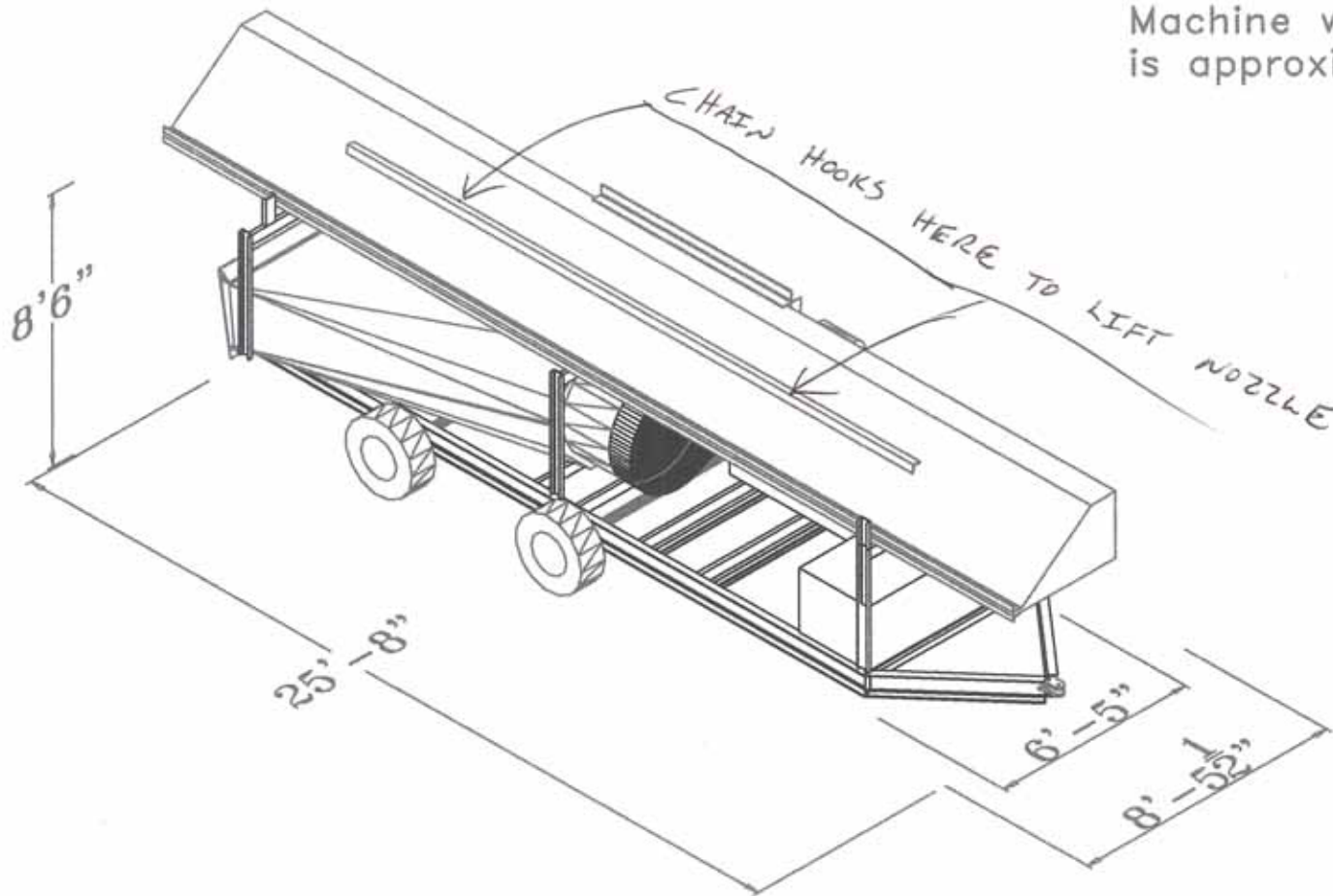

McPherson Systems Inc.

M30F ACD

Drawn: 3-25-99

(229) 386-2367





Purchasing Division  
 2019 Washington Street East  
 Post Office Box 50130  
 Charleston, WV 25305-0130

State of West Virginia  
 Request for Quotation  
 01 - Agricultural

Proc Folder: 266603

Doc Description: Trench/Air Curtain Burner

Proc Type: Central Purchase Order

Date Issued	Solicitation Closes	Solicitation No	Version
2016-10-24	2016-11-17 13:30:00	CRFQ 1400 AGR1700000006	1

**BID RECEIVING LOCATION**

BID CLERK  
 DEPARTMENT OF ADMINISTRATION  
 PURCHASING DIVISION  
 2019 WASHINGTON ST E  
 CHARLESTON WV 25305  
 US

**VENDOR**

Vendor Name, Address and Telephone Number:

**FOR INFORMATION CONTACT THE BUYER**

Linda Harper  
 (304) 558-0468  
 linda.b.harper@wv.gov

Signature X

FEIN #

58-1631110

DATE

11-16-16

All offers subject to all terms and conditions contained in this solicitation

**BID EXCEPTIONS – AIR CURTAIN BURNER (DEPT OF AGRICULTURE- WV)**

3.1.1.6 – Our design is shown on the drawings attached. We do not use a separate air carrier tube as the flow from the air curtain fan would be impeded too much for efficient burning.

3.1.1.7 - McPherson Systems can install brakes on both axles. As the air curtain destructor is considered an off-road piece of equipment, it will not be furnished with a Statement of Origin for a title or a 17 digit VIN.

3.1.1.9 – We do not provide torsion axles as the weight and design of the machine would damage them. We do provide 6 lugs axles rated at 5200 lbs each.

**DELIVERY OF THE MACHINE WILL NOT BE WITHIN THE 30 DAY TIME PERIOD REQUIRED. CURRENT DELIVERY TIMES ARE 6-8 WEEKS FROM PURCHASE ORDER CONFIRMATION.**

**NOTES:**

1. Our machine exceeds all of the other specifications given. It comes standard with a 4 cylinder turbocharged Perkins diesel engine rated at 99 hp.

REQUEST FOR QUOTATION  
**Trench/Air Curtain Burner**

---

failure to complete the Pricing Page in its entirety may result in Vendor's bid being disqualified.

**5. PAYMENT:**

**5.1 Payment:** Vendor shall accept payment in accordance with the payment procedures of the State of West Virginia.

**6. DELIVERY AND RETURN:**

**6.1 Shipment and Delivery:** Vendor shall ship the Contract Items immediately after being awarded this Contract and receiving a purchase order or notice to proceed. Vendor shall deliver the Contract Items ~~within 30 calendar days~~ after receiving a purchase order or notice to proceed. Contract Items must be delivered to **WV Conservation Agency at 255 Gus R. Douglass Lane, Charleston, WV 25312.**

**6.2 Late Delivery:** The Agency placing the order under this Contract must be notified in writing if the shipment of the Contract Items will be delayed for any reason. Any delay in delivery that could cause harm to an Agency will be grounds for cancellation of the Contract, and/or obtaining the Contract Items from a third party.

Any Agency seeking to obtain the Contract Items from a third party under this provision must first obtain approval of the Purchasing Division.

**6.3 Delivery Payment/Risk of Loss:** Vendor shall deliver the Contract Items F.O.B. destination to the Agency's location.

**6.4 Return of Unacceptable Items:** If the Agency deems the Contract Items to be unacceptable, the Contract Items shall be returned to Vendor at Vendor's expense and with no restocking charge. Vendor shall either make arrangements for the return within five (5) days of being notified that items are unacceptable, or permit the Agency to arrange for the return and reimburse Agency for delivery expenses. If the original packaging cannot be utilized for the return, Vendor will supply the Agency with appropriate return packaging upon request. All returns of unacceptable items shall be F.O.B. the Agency's location. The returned product shall either be replaced, or the Agency shall receive a full credit or refund for the purchase price, at the Agency's discretion.

**6.5 Return Due to Agency Error:** Items ordered in error by the Agency will be returned for credit within 30 days of receipt, F.O.B. Vendor's location. Vendor shall not charge a restocking fee if returned products are in a resalable condition.

Exception  
Delivery  
6-8 weeks  
from PO

REQUEST FOR QUOTATION  
**Trench/Air Curtain Burner**

---

Items shall be deemed to be in a resalable condition if they are unused and in the original packaging. Any restocking fee for items not in a resalable condition shall be the lower of the Vendor's customary restocking fee or 5% of the total invoiced value of the returned items.

**7 VENDOR DEFAULT:**

**7.1** The following shall be considered a vendor default under this Contract.

- 7.1.1** Failure to provide Contract Items in accordance with the requirements contained herein.
- 7.1.2** Failure to comply with other specifications and requirements contained herein.
- 7.1.3** Failure to comply with any laws, rules, and ordinances applicable to the Contract Services provided under this Contract.
- 7.1.4** Failure to remedy deficient performance upon request.

**7.2** The following remedies shall be available to Agency upon default.

- 7.2.1** Immediate cancellation of the Contract.
- 7.2.2** Immediate cancellation of one or more release orders issued under this Contract.
- 7.2.3** Any other remedies available in law or equity.

**Exhibit A - PRICING PAGE**

Section	Description	Alternate Part # and Description of or equal Products	Unit of Measure	Qty	Unit Price	Extended Price
3.1.1	Trench/Air Curtain Burner with 30 foot manifold.		EA	1	\$36,900.00/	\$36,900.00/
6.1	Freight		EA	1	\$1,950.00/	\$1,950.00/
					TOTAL BID AMOUNT	\$38,850.00/

Failure to use this form may result in disqualification

**Bidder/Vendor Information**

Name:	McPherson Systems Inc
Address:	3706 US HWY 82 WEST TIFTON, GA 31793
Phone:	229-386-2367
Email Address:	mcsales@mcphersys.com
Authorized Signature:	

**DESIGNATED CONTACT:** Vendor appoints the individual identified in this Section as the Contract Administrator and the initial point of contact for matters relating to this Contract.

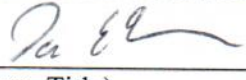
 Secretary  
(Name, Title)  
Dawn McPherson Secretary  
(Printed Name and Title)  
3706 US HWY 82 W TIFTON, GA 31793  
(Address)  
229-386-2367 / 229-387-0132  
(Phone Number) / (Fax Number)  
mcphers @ mcphersys . com  
(email address)

**CERTIFICATION AND SIGNATURE:** By signing below, or submitting documentation through wvOASIS, I certify that I have reviewed this Solicitation in its entirety; that I understand the requirements, terms and conditions, and other information contained herein; that this bid, offer or proposal constitutes an offer to the State that cannot be unilaterally withdrawn; that the product or service proposed meets the mandatory requirements contained in the Solicitation for that product or service, unless otherwise stated herein; that the Vendor accepts the terms and conditions contained in the Solicitation, unless otherwise stated herein; that I am submitting this bid, offer or proposal for review and consideration; that I am authorized by the vendor to execute and submit this bid, offer, or proposal, or any documents related thereto on vendor's behalf; that I am authorized to bind the vendor in a contractual relationship; and that to the best of my knowledge, the vendor has properly registered with any State agency that may require registration.

McPherson Systems Inc  
(Company)

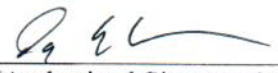
 Secretary  
(Authorized Signature) (Representative Name, Title)

Dawn McPherson, Secretary  
(Printed Name and Title of Authorized Representative)

11-16-16  
(Date)

229-386-2367 / 229-387-0132  
(Phone Number) (Fax Number)

REQUEST FOR QUOTATION  
**Trench/Air Curtain Burner**

---

**SPECIFICATIONS**

1. **PURPOSE AND SCOPE:** The West Virginia Purchasing Division is soliciting bids on behalf of WV Conservation Agency to establish a contract for the one time purchase of a trench/air curtain burner.
  
2. **DEFINITIONS:** The terms listed below shall have the meanings assigned to them below. Additional definitions can be found in section 2 of the General Terms and Conditions.
  - 2.1 **“Contract Item”** means, **Trench/Air Curtain On-site Waste Burning System**, as more fully described by these specifications.
  
  - 2.2 **“Pricing Page”** means the pages, contained in wvOASIS or attached as Exhibit A, upon which Vendor should list its proposed price for the Contract Items.
  
  - 2.3 **“Solicitation”** means the official notice of an opportunity to supply the State with goods or services that is published by the Purchasing Division.
  
3. **GENERAL REQUIREMENTS:**
  - 3.1 **Mandatory Contract Item Requirements:** Contract Item must meet or exceed the mandatory requirements listed below.
    - 3.1.1 **Trench/Air Curtain Burner**
      - 3.1.1.1 Trench/Air Curtain Burner must be trailer mounted for over-the-road transportability.
  
      - 3.1.1.2 Trench/Air Curtain Burner, must have Tier 3 diesel engine.
  
      - 3.1.1.3 Trench/Air Curtain Burner must have a 30-foot air-curtain manifold.
  
      - 3.1.1.4 Trench/Air Curtain Burner must have instrument panel to monitor oil pressure, water temperature, tachometer (engine revolutions per minute).

REQUEST FOR QUOTATION  
**Trench/Air Curtain Burner**

---

- Exception 3.1.1.5 Trench/Air Curtain Burner must have automatic emergency shut down safety feature in the event that the engine overheats or loses oil pressure.
- Exception 3.1.1.6 Trench/Air Curtain Burner must have air carrier pipe length of minimum 20 feet to provide adequate safe distance from burning trench.
- Exception 3.1.1.7 Trench/Air Curtain Burner must have dual axles with electric brakes on both axles.
- 3.1.1.8 Trench/Air Curtain Burner must have full trailer lighting for over-the-road transport.
- Exception 3.1.1.9 Trench/Air Curtain Burner must have maintenance-free independent torsion suspension system for better off road ground clearance and softer ride.
- 3.1.1.10 Trench/Air Curtain Burner must have minimum 1-year bumper to bumper warranty for defects in workmanship and materials from date of shipment from vendor.
- 3.1.1.11 Trench/Air Curtain Burner must have no on-site assembly and one person set-up with no additional equipment required.
- 3.1.1.12 Trench/Air Curtain Burner must come with one-time, on-site vendor training which includes hands-on use of the burner including an actual trench burn.

**4. CONTRACT AWARD:**

**4.1 Contract Award:** The Contract is intended to provide Agencies with a purchase price for the Contract Items. The Contract shall be awarded to the Vendor that provides the Contract Items meeting the required specifications for the lowest overall total cost as shown on the Pricing Pages.

**4.2 Pricing Page:** Vendor should complete the Pricing Page by reviewing the Pricing Page, completing the Unit Price, Extended Amount, Total Bid Amount, Bidder/Vendor Information, Name, Address, Phone, Email Address, and Authorized signature. Vendor should complete the Pricing Page in full as