



Purchasing Division
 2019 Washington Street East
 Post Office Box 50130
 Charleston, WV 25305-0130

State of West Virginia
 Request for Quotation
 09 - Construction

Proc Folder: 288932

Doc Description: MATERIALS & LABOR TO REPLACE CHILLER

Proc Type: Central Purchase Order

Date Issued	Solicitation Closes	Solicitation No	Version
2017-01-19	2017-02-16 13:30:00	CRFQ 0705 LOT1700000004	1

BID RECEIVING LOCATION:
 BID CLERK
 DEPARTMENT OF ADMINISTRATION
 PURCHASING DIVISION
 2019 WASHINGTON ST E
 CHARLESTON WV 25305
 US

VENDOR:
 Vendor Name, Address and Telephone Number:
 Dannold Mechanical Inc
 PO Box 149
 Kenna WV 25748
 304-988-1618

02/23/17 11:58:06
 Purchasing Division

FOR INFORMATION CONTACT THE BUYER
 Michelle L Childers
 (304) 558-2063
 michelle.l.childers@wv.gov

Signature X *Michelle L Childers* FEIN # 81-1092674 DATE 2-16-17
 All offers subject to all terms and conditions contained in this solicitation

Request for Quotation

The West Virginia Purchasing Division is soliciting bids on behalf of the West Virginia Lottery to establish a contract for the one time purchase of a chiller replacement as indicated in Exhibit B.

The Vendor shall furnish all materials, labor, and equipment necessary to complete all Construction Services. The Vendor shall furnish any incidental work, materials, labor, and equipment that are necessary to complete the Construction Services, even if such incidental work is not explicitly included in the specifications.

BILL TO		SHIP TO	
ACCOUNTS PAYABLE LOTTERY PO BOX 2067		PURCHASING LOTTERY 900 PENNSYLVANIA AVE	
CHARLESTON	WV25327-2067	CHARLESTON	WV 25302
US		US	

Line	Comm Ln Desc	Qty	Unit Issue	Unit Price	Total Price
1	MATERIALS & LABOR TO REPLACE CHILLER				

Comm Code	Manufacturer	Specification	Model #
40101714			

Extended Description :

Lump sum amount for materials and labor.

LOT1700000004	Document Phase Draft	Document Description MATERIALS & LABOR TO REPLACE CHILLER	Page 3
---------------	--------------------------------	------------------------------------------------------------------------	---------------

ADDITIONAL TERMS AND CONDITIONS

See attached document(s) for additional Terms and Conditions

INSTRUCTIONS TO VENDORS SUBMITTING BIDS

1. REVIEW DOCUMENTS THOROUGHLY: The attached documents contain a solicitation for bids. Please read these instructions and all documents attached in their entirety. These instructions provide critical information about requirements that if overlooked could lead to disqualification of a Vendor's bid. All bids must be submitted in accordance with the provisions contained in these instructions and the Solicitation. Failure to do so may result in disqualification of Vendor's bid.

2. MANDATORY TERMS: The Solicitation may contain mandatory provisions identified by the use of the words "must," "will," and "shall." Failure to comply with a mandatory term in the Solicitation will result in bid disqualification.

3. PREBID MEETING: The item identified below shall apply to this Solicitation.

A pre-bid meeting will not be held prior to bid opening

A **NON-MANDATORY PRE-BID** meeting will be held at the following place and time:

A **MANDATORY PRE-BID** meeting will be held at the following place and time:

West Virginia Lottery
900 Pennsylvania Avenue
Charleston, WV

February 2, 2017 at 2:00 PM EST.

All Vendors submitting a bid must attend the mandatory pre-bid meeting. Failure to attend the mandatory pre-bid meeting shall result in disqualification of the Vendor's bid. No one person attending the pre-bid meeting may represent more than one Vendor.

An attendance sheet provided at the pre-bid meeting shall serve as the official document verifying attendance. The State will not accept any other form of proof or documentation to verify attendance. Any person attending the pre-bid meeting on behalf of a Vendor must list on the attendance sheet his or her name and the name of the Vendor he or she is representing.

Additionally, the person attending the pre-bid meeting should include the Vendor's E-Mail address, phone number, and Fax number on the attendance sheet. It is the Vendor's responsibility to locate the attendance sheet and provide the required information. Failure to complete the attendance sheet as required may result in disqualification of Vendor's bid.

All Vendors should arrive prior to the starting time for the pre-bid. Vendors who arrive after the starting time but prior to the end of the pre-bid will be permitted to sign in, but are charged with knowing all matters discussed at the pre-bid.

Questions submitted at least five business days prior to a scheduled pre-bid will be discussed at the pre-bid meeting if possible. Any discussions or answers to questions at the pre-bid meeting are preliminary in nature and are non-binding. Official and binding answers to questions will be published in a written addendum to the Solicitation prior to bid opening.

4. VENDOR QUESTION DEADLINE: Vendors may submit questions relating to this Solicitation to the Purchasing Division. Questions must be submitted in writing. All questions must be submitted on or before the date listed below and to the address listed below in order to be considered. A written response will be published in a Solicitation addendum if a response is possible and appropriate. Non-written discussions, conversations, or questions and answers regarding this Solicitation are preliminary in nature and are nonbinding.

Submitted e-mails should have solicitation number in the subject line.

Question Submission Deadline: February 9, 2017 at 9:00 AM EST.

Submit Questions to: Michelle Childers
 2019 Washington Street, East
 Charleston, WV 25305
 Fax: (304) 558-4115 (Vendors should not use this fax number for bid submission)
 Email: Michelle.L.Childers@wv.gov

5. VERBAL COMMUNICATION: Any verbal communication between the Vendor and any State personnel is not binding, including verbal communication at the mandatory pre-bid conference. Only information issued in writing and added to the Solicitation by an official written addendum by the Purchasing Division is binding.

6. BID SUBMISSION: All bids must be submitted electronically through wvOASIS or signed and delivered by the Vendor to the Purchasing Division at the address listed below on or before the date and time of the bid opening. Any bid received by the Purchasing Division staff is considered to be in the possession of the Purchasing Division and will not be returned for any reason. The Purchasing Division will not accept bids, modification of bids, or addendum acknowledgment forms via e-mail. Acceptable delivery methods include electronic submission via wvOASIS, hand delivery, delivery by courier, or facsimile.

The bid delivery address is:
 Department of Administration, Purchasing Division
 2019 Washington Street East
 Charleston, WV 25305-0130

A bid that is not submitted electronically through wvOASIS should contain the information listed below on the face of the envelope or the bid may be rejected by the Purchasing Division.:

SEALED BID:
 BUYER:
 SOLICITATION NO.:
 BID OPENING DATE:
 BID OPENING TIME:
 FAX NUMBER:

The Purchasing Division may prohibit the submission of bids electronically through wvOASIS at its sole discretion. Such a prohibition will be contained and communicated in the wvOASIS system resulting in the Vendor's inability to submit bids through wvOASIS. Submission of a response to an Expression or Interest or Request for Proposal is not permitted in wvOASIS.

For Request For Proposal ("RFP") Responses Only: In the event that Vendor is responding to a request for proposal, the Vendor shall submit one original technical and one original cost proposal plus N/A convenience copies of each to the Purchasing Division at the address shown above. Additionally, the Vendor should identify the bid type as either a technical or cost proposal on the face of each bid envelope submitted in response to a request for proposal as follows:

BID TYPE: (This only applies to CRFP)

- Technical
 Cost

7. BID OPENING: Bids submitted in response to this Solicitation will be opened at the location identified below on the date and time listed below. Delivery of a bid after the bid opening date and time will result in bid disqualification. For purposes of this Solicitation, a bid is considered delivered when confirmation of delivery is provided by wvOASIS (in the case of electronic submission) or when the bid is time stamped by the official Purchasing Division time clock (in the case of hand delivery).

Bid Opening Date and Time: February 16, 2017 at 1:30 PM EST.

Bid Opening Location: Department of Administration, Purchasing Division
 2019 Washington Street East
 Charleston, WV 25305-0130

8. ADDENDUM ACKNOWLEDGEMENT: Changes or revisions to this Solicitation will be made by an official written addendum issued by the Purchasing Division. Vendor should acknowledge receipt of all addenda issued with this Solicitation by completing an Addendum Acknowledgment Form, a copy of which is included herewith. Failure to acknowledge addenda may result in bid disqualification. The addendum acknowledgement should be submitted with the bid to expedite document processing.

9. BID FORMATTING: Vendor should type or electronically enter the information onto its bid to prevent errors in the evaluation. Failure to type or electronically enter the information may result in bid disqualification.

10. ALTERNATES: Any model, brand, or specification listed in this Solicitation establishes the acceptable level of quality only and is not intended to reflect a preference for, or in any way favor, a particular brand or vendor. Vendors may bid alternates to a listed model or brand provided that the alternate is at least equal to the model or brand and complies with the required specifications. The equality of any alternate being bid shall be determined by the State at its sole discretion. Any Vendor bidding an alternate model or brand should clearly identify the alternate items in its bid and should include manufacturer's specifications, industry literature, and/or any other relevant documentation demonstrating the equality of the alternate items. Failure to provide information for alternate items may be grounds for rejection of a Vendor's bid.

11. EXCEPTIONS AND CLARIFICATIONS: The Solicitation contains the specifications that shall form the basis of a contractual agreement. Vendor shall clearly mark any exceptions, clarifications, or other proposed modifications in its bid. Exceptions to, clarifications of, or modifications of a requirement or term and condition of the Solicitation may result in bid disqualification.

12. COMMUNICATION LIMITATIONS: In accordance with West Virginia Code of State Rules §148-1-6.6, communication with the State of West Virginia or any of its employees regarding this Solicitation during the solicitation, bid, evaluation or award periods, except through the Purchasing Division, is strictly prohibited without prior Purchasing Division approval. Purchasing Division approval for such communication is implied for all agency delegated and exempt purchases.

13. REGISTRATION: Prior to Contract award, the apparent successful Vendor must be properly registered with the West Virginia Purchasing Division and must have paid the \$125 fee, if applicable.

14. UNIT PRICE: Unit prices shall prevail in cases of a discrepancy in the Vendor's bid.

15. PREFERENCE: Vendor Preference may only be granted upon written request and only in accordance with the West Virginia Code § 5A-3-37 and the West Virginia Code of State Rules. A Vendor Preference Certificate form has been attached hereto to allow Vendor to apply for the preference. Vendor's failure to submit the Vendor Preference Certificate form with its bid will result in denial of Vendor Preference. Vendor Preference does not apply to construction projects.

16. SMALL, WOMEN-OWNED, OR MINORITY-OWNED BUSINESSES: For any solicitations publicly advertised for bid, in accordance with West Virginia Code §5A-3-37(a)(7) and W. Va. CSR § 148-22-9, any non-resident vendor certified as a small, women-owned, or minority-owned business under W. Va. CSR § 148-22-9 shall be provided the same preference made available to any resident vendor. Any non-resident small, women-owned, or minority-owned business must identify itself as such in writing, must submit that writing to the Purchasing Division with its bid, and must be properly certified under W. Va. CSR § 148-22-9 prior to contract award to receive the preferences made available to resident vendors. Preference for a non-resident small, women-owned, or minority owned business shall be applied in accordance with W. Va. CSR § 148-22-9.

17. WAIVER OF MINOR IRREGULARITIES: The Director reserves the right to waive minor irregularities in bids or specifications in accordance with West Virginia Code of State Rules § 148-1-4.6.

18. ELECTRONIC FILE ACCESS RESTRICTIONS: Vendor must ensure that its submission in wvOASIS can be accessed and viewed by the Purchasing Division staff immediately upon bid opening. The Purchasing Division will consider any file that cannot be immediately accessed and viewed at the time of the bid opening (such as, encrypted files, password protected files, or incompatible files) to be blank or incomplete as context requires, and are therefore unacceptable. A vendor will not be permitted to unencrypt files, remove password protections, or resubmit documents after bid opening to make a file viewable if those documents are required with the bid. A Vendor may be required to provide document passwords or remove access restrictions to allow the Purchasing Division to print or electronically save documents provided that those documents are viewable by the Purchasing Division prior to obtaining the password or removing the access restriction.

19. NON-RESPONSIBLE: The Purchasing Division Director reserves the right to reject the bid of any vendor as Non-Responsible in accordance with W. Va. Code of State Rules § 148-1-5.3, when the Director determines that the vendor submitting the bid does not have the capability to fully perform, or lacks the integrity and reliability to assure good-faith performance.”

20. ACCEPTANCE/REJECTION: The State may accept or reject any bid in whole, or in part in accordance with W. Va. Code of State Rules § 148-1-4.5. and § 148-1-6.4.b.”

21. YOUR SUBMISSION IS A PUBLIC DOCUMENT: Vendor's entire response to the Solicitation and the resulting Contract are public documents. As public documents, they will be disclosed to the public following the bid/proposal opening or award of the contract, as required by the competitive bidding laws of West Virginia Code §§ 5A-3-1 et seq., 5-22-1 et seq., and 5G-1-1 et seq. and the Freedom of Information Act West Virginia Code §§ 29B-1-1 et seq.

DO NOT SUBMIT MATERIAL YOU CONSIDER TO BE CONFIDENTIAL, A TRADE SECRET, OR OTHERWISE NOT SUBJECT TO PUBLIC DISCLOSURE.

Submission of any bid, proposal, or other document to the Purchasing Division constitutes your explicit consent to the subsequent public disclosure of the bid, proposal, or document. The Purchasing Division will disclose any document labeled "confidential," "proprietary," "trade secret," "private," or labeled with any other claim against public disclosure of the documents, to include any "trade secrets" as defined by West Virginia Code § 47-22-1 et seq. All submissions are subject to public disclosure without notice.

GENERAL TERMS AND CONDITIONS:

1. CONTRACTUAL AGREEMENT: Issuance of a Award Document signed by the Purchasing Division Director, or his designee, and approved as to form by the Attorney General's office constitutes acceptance of this Contract made by and between the State of West Virginia and the Vendor. Vendor's signature on its bid signifies Vendor's agreement to be bound by and accept the terms and conditions contained in this Contract.

2. DEFINITIONS: As used in this Solicitation/Contract, the following terms shall have the meanings attributed to them below. Additional definitions may be found in the specifications included with this Solicitation/Contract.

2.1. "Agency" or "Agencies" means the agency, board, commission, or other entity of the State of West Virginia that is identified on the first page of the Solicitation or any other public entity seeking to procure goods or services under this Contract.

2.2. "Bid" or "Proposal" means the vendors submitted response to this solicitation.

2.3. "Contract" means the binding agreement that is entered into between the State and the Vendor to provide the goods or services requested in the Solicitation.

2.4. "Director" means the Director of the West Virginia Department of Administration, Purchasing Division.

2.5. "Purchasing Division" means the West Virginia Department of Administration, Purchasing Division.

2.6. "Award Document" means the document signed by the Agency and the Purchasing Division, and approved as to form by the Attorney General, that identifies the Vendor as the contract holder.

2.7. "Solicitation" means the official notice of an opportunity to supply the State with goods or services that is published by the Purchasing Division.

2.8. "State" means the State of West Virginia and/or any of its agencies, commissions, boards, etc. as context requires.

2.9. "Vendor" or "Vendors" means any entity submitting a bid in response to the Solicitation, the entity that has been selected as the lowest responsible bidder, or the entity that has been awarded the Contract as context requires.

3. CONTRACT TERM; RENEWAL; EXTENSION: The term of this Contract shall be determined in accordance with the category that has been identified as applicable to this Contract below:

Term Contract

Initial Contract Term: This Contract becomes effective on _____ and extends for a period of _____ year(s).

Renewal Term: This Contract may be renewed upon the mutual written consent of the Agency, and the Vendor, with approval of the Purchasing Division and the Attorney General's office (Attorney General approval is as to form only). Any request for renewal should be submitted to the Purchasing Division thirty (30) days prior to the expiration date of the initial contract term or appropriate renewal term. A Contract renewal shall be in accordance with the terms and conditions of the original contract. Renewal of this Contract is limited to _____ successive one (1) year periods or multiple renewal periods of less than one year, provided that the multiple renewal periods do not exceed _____ months in total. Automatic renewal of this Contract is prohibited. Notwithstanding the foregoing, Purchasing Division approval is not required on agency delegated or exempt purchases. Attorney General approval may be required for vendor terms and conditions.

Delivery Order Limitations: In the event that this contract permits delivery orders, a delivery order may only be issued during the time this Contract is in effect. Any delivery order issued within one year of the expiration of this Contract shall be effective for one year from the date the delivery order is issued. No delivery order may be extended beyond one year after this Contract has expired.

Fixed Period Contract: This Contract becomes effective upon Vendor's receipt of the notice to proceed and must be completed within sixty (60) days.

Fixed Period Contract with Renewals: This Contract becomes effective upon Vendor's receipt of the notice to proceed and part of the Contract more fully described in the attached specifications must be completed within _____ days.

Upon completion, the vendor agrees that maintenance, monitoring, or warranty services will be provided for one year thereafter with an additional _____ successive one year renewal periods or multiple renewal periods of less than one year provided that the multiple renewal periods do not exceed _____ months in total. Automatic renewal of this Contract is prohibited.

One Time Purchase: The term of this Contract shall run from the issuance of the Award Document until all of the goods contracted for have been delivered, but in no event will this Contract extend for more than one fiscal year.

Other: See attached.

4. NOTICE TO PROCEED: Vendor shall begin performance of this Contract immediately upon receiving notice to proceed unless otherwise instructed by the Agency. Unless otherwise specified, the fully executed Award Document will be considered notice to proceed.

5. QUANTITIES: The quantities required under this Contract shall be determined in accordance with the category that has been identified as applicable to this Contract below.

Open End Contract: Quantities listed in this Solicitation are approximations only, based on estimates supplied by the Agency. It is understood and agreed that the Contract shall cover the quantities actually ordered for delivery during the term of the Contract, whether more or less than the quantities shown.

Service: The scope of the service to be provided will be more clearly defined in the specifications included herewith.

Combined Service and Goods: The scope of the service and deliverable goods to be provided will be more clearly defined in the specifications included herewith.

One Time Purchase: This Contract is for the purchase of a set quantity of goods that are identified in the specifications included herewith. Once those items have been delivered, no additional goods may be procured under this Contract without an appropriate change order approved by the Vendor, Agency, Purchasing Division, and Attorney General's office.

6. EMERGENCY PURCHASES: The Purchasing Division Director may authorize the Agency to purchase goods or services in the open market that Vendor would otherwise provide under this Contract if those goods or services are for immediate or expedited delivery in an emergency. Emergencies shall include, but are not limited to, delays in transportation or an unanticipated increase in the volume of work. An emergency purchase in the open market, approved by the Purchasing Division Director, shall not constitute a breach of this Contract and shall not entitle the Vendor to any form of compensation or damages. This provision does not excuse the State from fulfilling its obligations under a One Time Purchase contract.

7. REQUIRED DOCUMENTS: All of the items checked below must be provided to the Purchasing Division by the Vendor as specified below.

BID BOND (Construction Only): Pursuant to the requirements contained in W. Va. Code § 5-22-1(c), All Vendors submitting a bid on a construction project shall furnish a valid bid bond in the amount of five percent (5%) of the total amount of the bid protecting the State of West Virginia. The bid bond must be submitted with the bid.

PERFORMANCE BOND: The apparent successful Vendor shall provide a performance bond in the amount of _____. The performance bond must be received by the Purchasing Division prior to Contract award. On construction contracts, the performance bond must be 100% of the Contract value.

LABOR/MATERIAL PAYMENT BOND: The apparent successful Vendor shall provide a labor/material payment bond in the amount of 100% of the Contract value. The labor/material payment bond must be delivered to the Purchasing Division prior to Contract award.

In lieu of the Bid Bond, Performance Bond, and Labor/Material Payment Bond, the Vendor may provide certified checks, cashier's checks, or irrevocable letters of credit. Any certified check, cashier's check, or irrevocable letter of credit provided in lieu of a bond must be of the same amount and delivered on the same schedule as the bond it replaces. A letter of credit submitted in lieu of a performance and labor/material payment bond will only be allowed for projects under \$100,000. Personal or business checks are not acceptable.

MAINTENANCE BOND: The apparent successful Vendor shall provide a two (2) year maintenance bond covering the roofing system. The maintenance bond must be issued and delivered to the Purchasing Division prior to Contract award.

LICENSE(S) / CERTIFICATIONS / PERMITS: In addition to anything required under the Section entitled Licensing, of the General Terms and Conditions, the apparent successful Vendor shall furnish proof of the following licenses, certifications, and/or permits prior to Contract award, in a form acceptable to the Purchasing Division.

WV Contractor's License

The apparent successful Vendor shall also furnish proof of any additional licenses or certifications contained in the specifications prior to Contract award regardless of whether or not that requirement is listed above.

8. INSURANCE: The apparent successful Vendor shall furnish proof of the insurance identified by a checkmark below prior to Contract award. Subsequent to contract award, and prior to the insurance expiration date, Vendor shall provide the Agency with proof that the insurance mandated herein has been continued. Vendor must also provide Agency with immediate notice of any changes in its insurance policies mandated herein, including but not limited to, policy cancelation, policy reduction, or change in insurers. The insurance coverages identified below must be maintained throughout the life of this contract. The apparent successful Vendor shall also furnish proof of any additional insurance requirements contained in the specifications prior to Contract award regardless of whether or not that insurance requirement is listed in this section.

Vendor must maintain:

Commercial General Liability Insurance in at least an amount of:
\$500,000.00

Automobile Liability Insurance in at least an amount of: _____

Professional/Malpractice/Errors and Omission Insurance in at least an amount of:

Commercial Crime and Third Party Fidelity Insurance in an amount of:

Cyber Liability Insurance in an amount of: _____

Builders Risk Insurance in an amount equal to 100% of the amount of the Contract.

9. WORKERS' COMPENSATION INSURANCE: The apparent successful Vendor shall comply with laws relating to workers compensation, shall maintain workers' compensation insurance when required, and shall furnish proof of workers' compensation insurance upon request.

10. LITIGATION BOND: The Director reserves the right to require any Vendor that files a protest of an award to submit a litigation bond in the amount equal to one percent of the lowest bid submitted or \$5,000, whichever is greater. The entire amount of the bond shall be forfeited if the hearing officer determines that the protest was filed for frivolous or improper purpose, including but not limited to, the purpose of harassing, causing unnecessary delay, or needless expense for the Agency. All litigation bonds shall be made payable to the Purchasing Division. In lieu of a bond, the protester may submit a cashier's check or certified check payable to the Purchasing Division. Cashier's or certified checks will be deposited with and held by the State Treasurer's office. If it is determined that the protest has not been filed for frivolous or improper purpose, the bond or deposit shall be returned in its entirety.

11. LIQUIDATED DAMAGES: Vendor shall pay liquidated damages in the amount of

for _____.

This clause shall in no way be considered exclusive and shall not limit the State or Agency's right to pursue any other available remedy.

12. ACCEPTANCE: Vendor's signature on its bid, or on the certification and signature page, constitutes an offer to the State that cannot be unilaterally withdrawn, signifies that the product or service proposed by vendor meets the mandatory requirements contained in the Solicitation for that product or service, unless otherwise indicated, and signifies acceptance of the terms and conditions contained in the Solicitation unless otherwise indicated.

13. PRICING: The pricing set forth herein is firm for the life of the Contract, unless specified elsewhere within this Solicitation/Contract by the State. A Vendor's inclusion of price adjustment provisions in its bid, without an express authorization from the State in the Solicitation to do so, may result in bid disqualification.

14. PAYMENT: Payment in advance is prohibited under this Contract. Payment may only be made after the delivery and acceptance of goods or services. The Vendor shall submit invoices, in arrears.

15. PURCHASING CARD ACCEPTANCE: The State of West Virginia currently utilizes a Purchasing Card program, administered under contract by a banking institution, to process payment for goods and services. The Vendor must accept the State of West Virginia's Purchasing Card for payment of all orders under this Contract unless the box below is checked.

Vendor is not required to accept the State of West Virginia's Purchasing Card as payment for all goods and services.

16. TAXES: The Vendor shall pay any applicable sales, use, personal property or any other taxes arising out of this Contract and the transactions contemplated thereby. The State of West Virginia is exempt from federal and state taxes and will not pay or reimburse such taxes.

17. ADDITIONAL FEES: Vendor is not permitted to charge additional fees or assess additional charges that were not either expressly provided for in the solicitation published by the State of West Virginia or included in the unit price or lump sum bid amount that Vendor is required by the solicitation to provide. Including such fees or charges as notes to the solicitation may result in rejection of vendor's bid. Requesting such fees or charges be paid after the contract has been awarded may result in cancellation of the contract.

18. FUNDING: This Contract shall continue for the term stated herein, contingent upon funds being appropriated by the Legislature or otherwise being made available. In the event funds are not appropriated or otherwise made available, this Contract becomes void and of no effect beginning on July 1 of the fiscal year for which funding has not been appropriated or otherwise made available.

19. CANCELLATION: The Purchasing Division Director reserves the right to cancel this Contract immediately upon written notice to the vendor if the materials or workmanship supplied do not conform to the specifications contained in the Contract. The Purchasing Division Director may also cancel any purchase or Contract upon 30 days written notice to the Vendor in accordance with West Virginia Code of State Rules § 148-1-5.2.b.

20. TIME: Time is of the essence with regard to all matters of time and performance in this Contract.

21. APPLICABLE LAW: This Contract is governed by and interpreted under West Virginia law without giving effect to its choice of law principles. Any information provided in specification manuals, or any other source, verbal or written, which contradicts or violates the West Virginia Constitution, West Virginia Code or West Virginia Code of State Rules is void and of no effect.

22. COMPLIANCE: Vendor shall comply with all applicable federal, state, and local laws, regulations and ordinances. By submitting a bid, Vendor acknowledges that it has reviewed, understands, and will comply with all applicable laws, regulations, and ordinances.

23. ARBITRATION: Any references made to arbitration contained in this Contract, Vendor's bid, or in any American Institute of Architects documents pertaining to this Contract are hereby deleted, void, and of no effect.

24. MODIFICATIONS: This writing is the parties' final expression of intent. Notwithstanding anything contained in this Contract to the contrary no modification of this Contract shall be binding without mutual written consent of the Agency, and the Vendor, with approval of the Purchasing Division and the Attorney General's office (Attorney General approval is as to form only). Any change to existing contracts that adds work or changes contract cost, and were not included in the original contract, must be approved by the Purchasing Division and the Attorney General's Office (as to form) prior to the implementation of the change or commencement of work affected by the change.

- 25. WAIVER:** The failure of either party to insist upon a strict performance of any of the terms or provision of this Contract, or to exercise any option, right, or remedy herein contained, shall not be construed as a waiver or a relinquishment for the future of such term, provision, option, right, or remedy, but the same shall continue in full force and effect. Any waiver must be expressly stated in writing and signed by the waiving party.
- 26. SUBSEQUENT FORMS:** The terms and conditions contained in this Contract shall supersede any and all subsequent terms and conditions which may appear on any form documents submitted by Vendor to the Agency or Purchasing Division such as price lists, order forms, invoices, sales agreements, or maintenance agreements, and includes internet websites or other electronic documents. Acceptance or use of Vendor's forms does not constitute acceptance of the terms and conditions contained thereon.
- 27. ASSIGNMENT:** Neither this Contract nor any monies due, or to become due hereunder, may be assigned by the Vendor without the express written consent of the Agency, the Purchasing Division, the Attorney General's office (as to form only), and any other government agency or office that may be required to approve such assignments. Notwithstanding the foregoing, Purchasing Division approval may or may not be required on certain agency delegated or exempt purchases.
- 28. WARRANTY:** The Vendor expressly warrants that the goods and/or services covered by this Contract will: (a) conform to the specifications, drawings, samples, or other description furnished or specified by the Agency; (b) be merchantable and fit for the purpose intended; and (c) be free from defect in material and workmanship.
- 29. STATE EMPLOYEES:** State employees are not permitted to utilize this Contract for personal use and the Vendor is prohibited from permitting or facilitating the same.
- 30. BANKRUPTCY:** In the event the Vendor files for bankruptcy protection, the State of West Virginia may deem this Contract null and void, and terminate this Contract without notice.
- 31. PRIVACY, SECURITY, AND CONFIDENTIALITY:** The Vendor agrees that it will not disclose to anyone, directly or indirectly, any such personally identifiable information or other confidential information gained from the Agency, unless the individual who is the subject of the information consents to the disclosure in writing or the disclosure is made pursuant to the Agency's policies, procedures, and rules. Vendor further agrees to comply with the Confidentiality Policies and Information Security Accountability Requirements, set forth in <http://www.state.wv.us/admin/purchase/privacy/default.html>.

32. YOUR SUBMISSION IS A PUBLIC DOCUMENT: Vendor's entire response to the Solicitation and the resulting Contract are public documents. As public documents, they will be disclosed to the public following the bid/proposal opening or award of the contract, as required by the competitive bidding laws of West Virginia Code §§ 5A-3-1 et seq., 5-22-1 et seq., and 5G-1-1 et seq. and the Freedom of Information Act West Virginia Code §§ 29B-1-1 et seq.

DO NOT SUBMIT MATERIAL YOU CONSIDER TO BE CONFIDENTIAL, A TRADE SECRET, OR OTHERWISE NOT SUBJECT TO PUBLIC DISCLOSURE.

Submission of any bid, proposal, or other document to the Purchasing Division constitutes your explicit consent to the subsequent public disclosure of the bid, proposal, or document. The Purchasing Division will disclose any document labeled "confidential," "proprietary," "trade secret," "private," or labeled with any other claim against public disclosure of the documents, to include any "trade secrets" as defined by West Virginia Code § 47-22-1 et seq. All submissions are subject to public disclosure without notice.

33. LICENSING: In accordance with West Virginia Code of State Rules § 148-1-6.1.e, Vendor must be licensed and in good standing in accordance with any and all state and local laws and requirements by any state or local agency of West Virginia, including, but not limited to, the West Virginia Secretary of State's Office, the West Virginia Tax Department, West Virginia Insurance Commission, or any other state agency or political subdivision. Upon request, the Vendor must provide all necessary releases to obtain information to enable the Purchasing Division Director or the Agency to verify that the Vendor is licensed and in good standing with the above entities.

34. ANTITRUST: In submitting a bid to, signing a contract with, or accepting a Award Document from any agency of the State of West Virginia, the Vendor agrees to convey, sell, assign, or transfer to the State of West Virginia all rights, title, and interest in and to all causes of action it may now or hereafter acquire under the antitrust laws of the United States and the State of West Virginia for price fixing and/or unreasonable restraints of trade relating to the particular commodities or services purchased or acquired by the State of West Virginia. Such assignment shall be made and become effective at the time the purchasing agency tenders the initial payment to Vendor.

35. VENDOR CERTIFICATIONS: By signing its bid or entering into this Contract, Vendor certifies (1) that its bid or offer was made without prior understanding, agreement, or connection with any corporation, firm, limited liability company, partnership, person or entity submitting a bid or offer for the same material, supplies, equipment or services; (2) that its bid or offer is in all respects fair and without collusion or fraud; (3) that this Contract is accepted or entered into without any prior understanding, agreement, or connection to any other entity that could be considered a violation of law; and (4) that it has reviewed this Solicitation in its entirety; understands the requirements, terms and conditions, and other information contained herein.

Vendor's signature on its bid or offer also affirms that neither it nor its representatives have any interest, nor shall acquire any interest, direct or indirect, which would compromise the performance of its services hereunder. Any such interests shall be promptly presented in detail to the Agency. The individual signing this bid or offer on behalf of Vendor certifies that he or she is authorized by the Vendor to execute this bid or offer or any documents related thereto on Vendor's behalf; that he or she is authorized to bind the Vendor in a contractual relationship; and that, to the best of his or her knowledge, the Vendor has properly registered with any State agency that may require registration.

36. VENDOR RELATIONSHIP: The relationship of the Vendor to the State shall be that of an independent contractor and no principal-agent relationship or employer-employee relationship is contemplated or created by this Contract. The Vendor as an independent contractor is solely liable for the acts and omissions of its employees and agents. Vendor shall be responsible for selecting, supervising, and compensating any and all individuals employed pursuant to the terms of this Solicitation and resulting contract. Neither the Vendor, nor any employees or subcontractors of the Vendor, shall be deemed to be employees of the State for any purpose whatsoever. Vendor shall be exclusively responsible for payment of employees and contractors for all wages and salaries, taxes, withholding payments, penalties, fees, fringe benefits, professional liability insurance premiums, contributions to insurance and pension, or other deferred compensation plans, including but not limited to, Workers' Compensation and Social Security obligations, licensing fees, etc. and the filing of all necessary documents, forms, and returns pertinent to all of the foregoing.

Vendor shall hold harmless the State, and shall provide the State and Agency with a defense against any and all claims including, but not limited to, the foregoing payments, withholdings, contributions, taxes, Social Security taxes, and employer income tax returns.

37. INDEMNIFICATION: The Vendor agrees to indemnify, defend, and hold harmless the State and the Agency, their officers, and employees from and against: (1) Any claims or losses for services rendered by any subcontractor, person, or firm performing or supplying services, materials, or supplies in connection with the performance of the Contract; (2) Any claims or losses resulting to any person or entity injured or damaged by the Vendor, its officers, employees, or subcontractors by the publication, translation, reproduction, delivery, performance, use, or disposition of any data used under the Contract in a manner not authorized by the Contract, or by Federal or State statutes or regulations; and (3) Any failure of the Vendor, its officers, employees, or subcontractors to observe State and Federal laws including, but not limited to, labor and wage and hour laws.

38. PURCHASING AFFIDAVIT: In accordance with West Virginia Code § 5A-3-10a, all Vendors are required to sign, notarize, and submit the Purchasing Affidavit stating that neither the Vendor nor a related party owe a debt to the State in excess of \$1,000. The affidavit must be submitted prior to award, but should be submitted with the Vendor's bid. A copy of the Purchasing Affidavit is included herewith.

39. ADDITIONAL AGENCY AND LOCAL GOVERNMENT USE: This Contract may be utilized by other agencies, spending units, and political subdivisions of the State of West Virginia; county, municipal, and other local government bodies; and school districts ("Other Government Entities"). Any extension of this Contract to the aforementioned Other Government Entities must be on the same prices, terms, and conditions as those offered and agreed to in this Contract, provided that such extension is in compliance with the applicable laws, rules, and ordinances of the Other Government Entity. If the Vendor does not wish to extend the prices, terms, and conditions of its bid and subsequent contract to the Other Government Entities, the Vendor must clearly indicate such refusal in its bid. A refusal to extend this Contract to the Other Government Entities shall not impact or influence the award of this Contract in any manner.

40. CONFLICT OF INTEREST: Vendor, its officers or members or employees, shall not presently have or acquire an interest, direct or indirect, which would conflict with or compromise the performance of its obligations hereunder. Vendor shall periodically inquire of its officers, members and employees to ensure that a conflict of interest does not arise. Any conflict of interest discovered shall be promptly presented in detail to the Agency.

41. REPORTS: Vendor shall provide the Agency and/or the Purchasing Division with the following reports identified by a checked box below:

Such reports as the Agency and/or the Purchasing Division may request. Requested reports may include, but are not limited to, quantities purchased, agencies utilizing the contract, total contract expenditures by agency, etc.

Quarterly reports detailing the total quantity of purchases in units and dollars, along with a listing of purchases by agency. Quarterly reports should be delivered to the Purchasing Division via email at purchasing.requisitions@wv.gov.

42. BACKGROUND CHECK: In accordance with W. Va. Code § 15-2D-3, the Director of the Division of Protective Services shall require any service provider whose employees are regularly employed on the grounds or in the buildings of the Capitol complex or who have access to sensitive or critical information to submit to a fingerprint-based state and federal background inquiry through the state repository. The service provider is responsible for any costs associated with the fingerprint-based state and federal background inquiry.

After the contract for such services has been approved, but before any such employees are permitted to be on the grounds or in the buildings of the Capitol complex or have access to sensitive or critical information, the service provider shall submit a list of all persons who will be physically present and working at the Capitol complex to the Director of the Division of Protective Services for purposes of verifying compliance with this provision. The State reserves the right to prohibit a service provider's employees from accessing sensitive or critical information or to be present at the Capitol complex based upon results addressed from a criminal background check.

Service providers should contact the West Virginia Division of Protective Services by phone at (304) 558-9911 for more information.

43. PREFERENCE FOR USE OF DOMESTIC STEEL PRODUCTS: Except when authorized by the Director of the Purchasing Division pursuant to W. Va. Code § 5A-3-56, no contractor may use or supply steel products for a State Contract Project other than those steel products made in the United States. A contractor who uses steel products in violation of this section may be subject to civil penalties pursuant to W. Va. Code § 5A-3-56. As used in this section:

- a. "State Contract Project" means any erection or construction of, or any addition to, alteration of or other improvement to any building or structure, including, but not limited to, roads or highways, or the installation of any heating or cooling or ventilating plants or other equipment, or the supply of and materials for such projects, pursuant to a contract with the State of West Virginia for which bids were solicited on or after June 6, 2001.
- b. "Steel Products" means products rolled, formed, shaped, drawn, extruded, forged, cast, fabricated or otherwise similarly processed, or processed by a combination of two or more or such operations, from steel made by the open heath, basic oxygen, electric furnace, Bessemer or other steel making process. The Purchasing Division Director may, in writing, authorize the use of foreign steel products if:
 - c. The cost for each contract item used does not exceed one tenth of one percent (.1%) of the total contract cost or two thousand five hundred dollars (\$2,500.00), whichever is greater. For the purposes of this section, the cost is the value of the steel product as delivered to the project; or
 - d. The Director of the Purchasing Division determines that specified steel materials are not produced in the United States in sufficient quantity or otherwise are not reasonably available to meet contract requirements.

44. PREFERENCE FOR USE OF DOMESTIC ALUMINUM, GLASS, AND STEEL: In Accordance with W. Va. Code § 5-19-1 et seq., and W. Va. CSR § 148-10-1 et seq., for every contract or subcontract, subject to the limitations contained herein, for the construction, reconstruction, alteration, repair, improvement or maintenance of public works or for the purchase of any item of machinery or equipment to be used at sites of public works, only domestic aluminum, glass or steel products shall be supplied unless the spending officer determines, in writing, after the receipt of offers or bids, (1) that the cost of domestic aluminum, glass or steel products is unreasonable or inconsistent with the public interest of the State of West Virginia, (2) that domestic aluminum, glass or steel products are not produced in sufficient quantities to meet the contract requirements, or (3) the available domestic aluminum, glass, or steel do not meet the contract specifications. This provision only applies to public works contracts awarded in an amount more than fifty thousand dollars (\$50,000) or public works contracts that require more than ten thousand pounds of steel products.

The cost of domestic aluminum, glass, or steel products may be unreasonable if the cost is more than twenty percent (20%) of the bid or offered price for foreign made aluminum, glass, or steel products. If the domestic aluminum, glass or steel products to be supplied or produced in a "substantial labor surplus area", as defined by the United States Department of Labor, the cost of domestic aluminum, glass, or steel products may be unreasonable if the cost is more than thirty percent (30%) of the bid or offered price for foreign made aluminum, glass, or steel products. This preference shall be applied to an item of machinery or equipment, as indicated above, when the item is a single unit of equipment or machinery manufactured primarily of aluminum, glass or steel, is part of a public works contract and has the sole purpose or of being a permanent part of a single public works project. This provision does not apply to equipment or machinery purchased by a spending unit for use by that spending unit and not as part of a single public works project.

All bids and offers including domestic aluminum, glass or steel products that exceed bid or offer prices including foreign aluminum, glass or steel products after application of the preferences provided in this provision may be reduced to a price equal to or lower than the lowest bid or offer price for foreign aluminum, glass or steel products plus the applicable preference. If the reduced bid or offer prices are made in writing and supersede the prior bid or offer prices, all bids or offers, including the reduced bid or offer prices, will be reevaluated in accordance with this rule.

ADDITIONAL TERMS AND CONDITIONS (Construction Contracts Only)

1. CONTRACTOR'S LICENSE: West Virginia Code § 21-11-2 requires that all persons desiring to perform contracting work in this state be licensed. The West Virginia Contractors Licensing Board is empowered to issue the contractor's license. Applications for a contractor's license may be made by contacting the West Virginia Division of Labor. West Virginia Code § 21-11-11 requires any prospective Vendor to include the contractor's license number on its bid. Failure to include a contractor's license number on the bid shall result in Vendor's bid being disqualified. Vendors should include a contractor's license number in the space provided below.

Contractor's Name: Dar nold Mechanical Inc
 Contractor's License No.: WV- 054588

The apparent successful Vendor must furnish a copy of its contractor's license prior to the issuance of a Award Document.

2. DRUG-FREE WORKPLACE AFFIDAVIT: W. Va. Code § 21-1D-5 provides that any solicitation for a public improvement contract requires each Vendor that submits a bid for the work to submit at the same time an affidavit that the Vendor has a written plan for a drug-free workplace policy. To comply with this law, Vendor must either complete the enclosed drug-free workplace affidavit and submit the same with its bid or complete a similar affidavit that fulfills all of the requirements of the applicable code. Failure to submit the signed and notarized drug-free workplace affidavit or a similar affidavit that fully complies with the requirements of the applicable code, with the bid shall result in disqualification of Vendor's bid. Pursuant to W. Va. Code 21-1D-2(b) and (k), this provision does not apply to public improvement contracts the value of which is \$100,000 or less or temporary or emergency repairs.

2.1. DRUG-FREE WORKPLACE POLICY: Pursuant to W. Va. Code § 21-1D-4, Vendor and its subcontractors must implement and maintain a written drug-free workplace policy that complies with said article. The awarding public authority shall cancel this contract if: (1) Vendor fails to implement and maintain a written drug-free workplace policy described in the preceding paragraph, (2) Vendor fails to provide information regarding implementation of its drug-free workplace policy at the request of the public authority; or (3) Vendor provides to the public authority false information regarding the contractor's drug-free workplace policy.

Pursuant to W. Va. Code 21-1D-2(b) and (k), this provision does not apply to public improvement contracts the value of which is \$100,000 or less or temporary or emergency repairs.

3. DRUG FREE WORKPLACE REPORT: Pursuant to W. Va. Code § 21-1D-7b, no less than once per year, or upon completion of the project, every contractor shall provide a certified report to the public authority which let the contract. For contracts over \$25,000, the public authority shall be the West Virginia Purchasing Division. For contracts of \$25,000 or less, the public authority shall be the agency issuing the contract. The report shall include:

(1) Information to show that the education and training service to the requirements of West Virginia Code § 21-1D-5 was provided;

- (2) The name of the laboratory certified by the United States Department of Health and Human Services or its successor that performs the drug tests;
- (3) The average number of employees in connection with the construction on the public improvement;
- (4) Drug test results for the following categories including the number of positive tests and the number of negative tests: (A) Pre-employment and new hires; (B) Reasonable suspicion; (C) Post-accident; and (D) Random.

Vendor should utilize the attached Certified Drug Free Workplace Report Coversheet when submitting the report required hereunder. Pursuant to W. Va. Code 21-1D-2(b) and (k), this provision does not apply to public improvement contracts the value of which is \$100,000 or less or temporary or emergency repairs.

4. AIA DOCUMENTS: All construction contracts that will be completed in conjunction with architectural services procured under Chapter 5G of the West Virginia Code will be governed by the AIA A101-2007 and A201-2007 or the A107-2007 documents, as amended by the Supplementary Conditions for the State of West Virginia, in addition to the terms and conditions contained herein.

5. GREEN BUILDINGS MINIMUM ENERGY STANDARDS: In accordance with § 22-29-4, all new building construction projects of public agencies that have not entered the schematic design phase prior to July 1, 2012, or any building construction project receiving state grant funds and appropriations, including public schools, that have not entered the schematic design phase prior to July 1, 2012, shall be designed and constructed complying with the ICC International Energy Conservation Code, adopted by the State Fire Commission, and the ANSI/ASHRAE/IESNA Standard 90.1-2007: Provided, That if any construction project has a commitment of federal funds to pay for a portion of such project, this provision shall only apply to the extent such standards are consistent with the federal standards.

6. LOCAL LABOR MARKET HIRING REQUIREMENT: Pursuant to West Virginia Code §21-1C-1 et seq., Employers shall hire at least seventy-five percent of employees for public improvement construction projects from the local labor market, to be rounded off, with at least two employees from outside the local labor market permissible for each employer per project.

Any employer unable to employ the minimum number of employees from the local labor market shall inform the nearest office of the bureau of employment programs' division of employment services of the number of qualified employees needed and provide a job description of the positions to be filled.

If, within three business days following the placing of a job order, the division is unable to refer any qualified job applicants to the employer or refers less qualified job applicants than the number requested, then the division shall issue a waiver to the employer stating the unavailability of applicant and shall permit the employer to fill any positions covered by the waiver from outside the local labor market. The waiver shall be either oral or in writing and shall be issued within the prescribed three days. A waiver certificate shall be sent to both the employer for its permanent project records and to the public authority.

Any employer who violates any provision of this article is subject to a civil penalty of one hundred dollars per day of violation. The West Virginia Division of Labor is responsible for establishing procedures for the collection of civil penalties.

The following terms used in this section have the meaning shown below.

(1) The term "construction project" means any construction, reconstruction, improvement, enlargement, painting, decorating or repair of any public improvement let to contract in an amount equal to or greater than \$500,000. The term "construction project" does not include temporary or emergency repairs;

(2) The term "employee" means any person hired or permitted to perform hourly work for wages by a person, firm or corporation in the construction industry; The term "employee" does not include:(i) Bona fide employees of a public authority or individuals engaged in making temporary or emergency repairs;(ii) Bona fide independent contractors; or(iii) Salaried supervisory personnel necessary to assure efficient execution of the employee's work;

(3) The term "employer" means any person, firm or corporation employing one or more employees on any public improvement and includes all contractors and subcontractors;

(4) The term "local labor market" means every county in West Virginia and any county outside of West Virginia if any portion of that county is within fifty miles of the border of West Virginia;

(5) The term "public improvement" includes the construction of all buildings, roads, highways, bridges, streets, alleys, sewers, ditches, sewage disposal plants, waterworks, airports and all other structures that may be let to contract by a public authority, excluding improvements funded, in whole or in part, by federal funds.

7. DAVIS-BACON AND RELATED ACT WAGE RATES:

- The work performed under this contract is federally funded in whole, or in part. Pursuant to _____, Vendors are required to pay applicable Davis-Bacon wage rates.
- The work performed under this contract is not subject to Davis-Bacon wage rates.

8. SUBCONTRACTOR LIST SUBMISSION: In accordance with W. Va. Code § 5-22-1, the apparent low bidder on a contract valued at more than \$250,000.00 for the construction, alteration, decoration, painting or improvement of a new or existing building or structure shall submit a list of all subcontractors who will perform more than \$25,000.00 of work on the project including labor and materials. If no subcontractors who will perform more than \$25,000.00 of work are to be used to complete the project, it must be noted on the subcontractor list. Failure to submit the subcontractor list within one business day after the deadline for submitting bids shall result in disqualification of the bid. This provision does not apply to any other construction projects, such as highway, mine reclamation, water or sewer projects.

a. Required Information. The subcontractor list shall contain the following information:

- i. Bidder's name
- ii. Name of each subcontractor performing more than \$25,000 of work on the project.

iii. The license number of each subcontractor, as required by W. Va. Code § 21-11-1 et. seq.

iv. If applicable, a notation that no subcontractor will be used to perform more than \$25,000.00 of work.

b. Subcontractor List Submission Form: The subcontractor list may be submitted in any form, including the attached form, as long as the required information noted above is included. If any information is missing from the bidder's subcontractor list submission, it may be obtained from other documents such as bids, emails, letters, etc. that accompany the subcontractor list submission.

c. Submission of Subcontractor List for Solicitations with Additions/Alternates: If the solicitation contains potential additions or alternates that will be selected by the Agency after bid opening and prior to contract award, all bidders must submit the subcontractor list to the Purchasing Division within one business day of the opening of bids for review. A bidder's failure to submit the subcontractor list within one business day after the deadline for submitting bids shall result in disqualification of the bidder's bid.

d. Substitution of Subcontractor. Written approval must be obtained from the State Spending Unit before any subcontractor substitution is permitted. Substitutions are not permitted unless:

- i. The subcontractor listed in the original bid has filed for bankruptcy;
- ii. The subcontractor in the original bid has been debarred or suspended; or
- iii. The contractor certifies in writing that the subcontractor listed in the original bid fails, is unable, or refuses to perform his subcontract.

Subcontractor List Submission (Construction Contracts Only)

Bidder's Name: Darnold Mechanical Inc.

Check this box if no subcontractors will perform more than \$25,000.00 of work to complete the project.

Subcontractor Name	License Number if Required by W. Va. Code § 21-11-1 et. seq.
Burdette Electric	WV034524
Bell Mechanical	WV005808

Attach additional pages if necessary

REQUEST FOR QUOTATION
Chiller Replacement

GENERAL CONSTRUCTION SPECIFICATIONS (No AIA Documents)

1. **PURPOSE AND SCOPE:** The West Virginia Purchasing Division is soliciting bids on behalf of the West Virginia Lottery to establish a contract for the one time purchase of a chiller replacement as indicated in Exhibit B.

The Vendor shall furnish all materials, labor, and equipment necessary to complete all Construction Services. The Vendor shall furnish any incidental work, materials, labor, and equipment that are necessary to complete the Construction Services, even if such incidental work is not explicitly included in the specifications.

2. **DEFINITIONS:** The terms listed below shall have the meanings assigned to them below. Additional definitions can be found in section 2 of the General Terms and Conditions and in the Project Plans as defined below.
 - 2.1 **“Construction Services”** means the removal and disposal of an existing 100 ton Trane chiller, the installation of a 75 ton air-cooled scroll chiller and the startup of the new chiller as more fully described in these specifications.
 - 2.2 **“Pricing Page”** means the pages contained in wvOASIS, attached hereto as Exhibit A, or included in the Project Plans upon which Vendor should list its proposed price for the Construction Services.
 - 2.3 **“Solicitation”** means the official notice of an opportunity to supply the State with Construction Services that is published by the Purchasing Division.
 - 2.4 **“Project Plans”** means documents developed by an architect, an engineer, the Agency, or another design professional, which are attached hereto as Exhibit B, that provide detailed instructions on how the Construction Services are to be performed. In the event that Project Plans contain drawings or other documents too large to attach in Exhibit B, Vendors can obtain copies in accordance with Section 9 of these Specifications.

3. **ORDER OF PRECEDENCE:** This General Construction Specifications document will have priority over, and supersede, anything contained in the Project Plans.

4. **QUALIFICATIONS:** Vendor, or Vendor’s staff if requirements are inherently limited to individuals rather than corporate entities, shall have the following minimum qualifications:

- 4.1. **Experience:** Vendor, or Vendor’s supervisory staff assigned to this project, must have successfully completed at least five projects that involved work similar to that described in these specifications or the Project Plans. Compliance with this experience requirement will be determined prior to contract award by the State through references provided by

REQUEST FOR QUOTATION
Chiller Replacement

the Vendor upon request, through knowledge or documentation of the Vendor's past projects, through confirmation of experience requirements from the architect assisting the State in this project, or some other method that the State determines to be acceptable. Vendor must provide any documentation requested by the State to assist in confirmation of compliance with this provision. References, documentation, or other information to confirm compliance with this experience requirement may be requested after bid opening and prior to contract award.

4.2. The vendor shall possess the proper manufacturer's certification for the particular brand of equipment that is being installed.

5. **CONTRACT AWARD:** The Contract is intended to provide Agency with a purchase price for the Construction Services. The Contract will be awarded to the lowest qualified responsible bidder meeting the required specifications. If the Pricing Pages contain alternates/add-ons, the Contract will be awarded based on the grand total of the base bid and any alternates/add-ons selected.
6. **SELECTION OF ALTERNATES:** If the Pricing Pages contain alternates/add-ons, the alternates/add-ons will be selected as follows. The alternate/add-on will be selected in the order of priority listed on the Pricing Pages. The first alternate/add-on must be selected before the second alternate/add-on can be selected and so on.
7. **PERFORMANCE:** Vendor shall perform the Construction Services in accordance with this document and the Project Plans.
8. **SUBSTITUTIONS:** Any substitution requests must be submitted in accordance with the official question and answer period described in the INSTRUCTIONS TO VENDORS SUBMITTING BIDS, Paragraph 4. Vendor Question Deadline. Vendors submitting substitution requests should submit product brochures and product specifications during the official question and answer period.
9. **PROJECT PLANS:** The checked box will apply to Project Plans for this solicitation.
 - No Additional Project Plan Documents:** There are no additional Project Plans other than those attached hereto as Exhibit B or any subsequent addenda modifying Exhibit B.
 - Additional Project Plan Documents:** There are additional Project Plan documents other than those attached as Exhibit B. Copies of the additional Project Plan documents not attached as Exhibit B can be obtained by contacting the entity identified below.

REQUEST FOR QUOTATION
Chiller Replacement

10. CONDITIONS OF THE WORK

10.1. Permits: The Vendor shall procure all necessary permits and licenses to comply with all applicable Federal, State, or Local laws, regulations and ordinances of any regulating body.

10.2. Existing Conditions: If discrepancies are discovered between the existing conditions and those noted in the specifications, Vendor must immediately notify the Agency's representative. Vendor must also immediately notify the Agency if suspected hazardous materials are encountered.

10.3. Standard Work Hours: The standard hours of work for this Contract will be 7:00am – 5:00pm Est. Monday - Friday excluding holidays recognized by the State of West Virginia. Any work outside of the standard hours of work must be approved in advance at the Agency's sole discretion. Authorization of work outside of the standard hours of work will not entitle Vendor to additional compensation.

10.4. Project Closeout: Project Closeout shall include the following:

10.4.1. Final Cleanup: Vendor shall perform the final cleanup activities listed below, along with any other final cleanup activities normally associated with the work performed under this Contract, prior to final inspection:

10.4.1.1. Remove from the site all unused materials, equipment and debris associated with the work.

10.4.1.2. Remove and clean from the project area all dirt, stains, oil, grease, etc. associated with the work.

10.4.1.3. The project area shall be returned to the West Virginia Lottery in the same condition as it was prior to the start of the work.

10.4.2. Final Inspection: Vendor shall participate in a final inspection with the Agency's project manager. The purpose of the final inspection will be to identify deficiencies that need to be remedied prior to Agency's final acceptance of the work. Vendor shall at all times be obligated to perform in accordance with the Contract and must take all actions necessary to ensure that work complies with requirements of Contract prior to final acceptance. Final acceptance does not waive or release Vendor from its obligation to ensure that work complies with the Contract requirements. Vendor shall

REQUEST FOR QUOTATION
Chiller Replacement

submit any warranty documents to the Agency project manager at final inspection.

11. FACILITIES ACCESS: Performance of Contract Services may require access cards and/or keys to gain entrance to Agency's facilities. In the event that access cards and/or keys are required:

11.1. Vendor must identify principal service personnel which will be issued access cards and/or keys to perform service.

11.2. Vendor will be responsible for controlling cards and keys and will pay replacement fee, if the cards or keys become lost or stolen.

11.3. Vendor shall notify Agency immediately of any lost, stolen, or missing card or key.

11.4. Anyone performing under this Contract will be subject to Agency's security protocol and procedures.

11.5. Vendor shall inform all staff of Agency's security protocol and procedures.

12. MISCELLANEOUS:

12.1. Contract Manager: During its performance of this Contract, Vendor must designate and maintain a primary contract manager responsible for overseeing Vendor's responsibilities under this Contract. The Contract manager must be available during normal business hours to address any customer service or other issues related to this Contract. Vendor should list its Contract manager and his or her contact information below.

Contract Manager: Scott Darnold

Telephone Number: 304-539-0930

Fax Number: _____

Email Address: Sdarnold@darnoldmech.com

REQUEST FOR QUOTATION
Chiller Replacement

EXHIBIT A – Pricing Page

DATE: 2-14-17

NAME OF VENDOR: Darhdd Mechanical Inc.

The aforementioned, hereinafter called Vendor, being familiar with and understanding the Bidding Documents and also having examined the site and being familiar with all local conditions affecting the project hereby proposes to furnish all labor, material, equipment, supplies and transportation and to perform all Work in accordance with the Bidding Documents within the time set forth for the sum of:

BASE BID:

For the sum of: One Hundred + en + thousand six hundred dollars
(\$ 10,600.00)

(Show amount in both words and numbers)

REQUEST FOR QUOTATION
Chiller Replacement

EXHIBIT B – GENERAL REQUIREMENTS

1. The existing 100 ton Trane chiller shall be disconnected from the facility HVAC system and disposed offsite.
2. The new chiller shall be installed according to the manufacturer's technical specifications and safety precautions.
3. The new chiller shall be a 75 ton, air-cooled, packaged unit, scroll type chiller such as Daikin AGZ075E or equal.
4. The new chiller shall be connected to and fully operational with the existing make-up air system that serves the facility Daikin variable refrigerant volume HVAC system. The new chiller shall also be connected to and fully operational with the existing facility Andover building automation system.
5. Delivery of materials to the site and the scheduling of all work on site shall be coordinated with the West Virginia Lottery facility manager David Oliverio.
6. All work shall be scheduled in order to not disrupt ordinary business activities such as blocking access to West Virginia Lottery property or negatively impacting business meetings and functions.
7. The contractor shall provide a factory authorized of the new chiller. The startup shall consist of testing the chiller for both hardware and software functionality. The new chiller shall operate under the control of the existing facility Building Automation System and shall be tested against the appropriate sequence of operation for functionality and compatibility. A written report shall be submitted to the West Virginia Lottery indicating that the installed chiller functions in accordance with the manufacturer's specifications and is fully compatible with the existing Building Automation System.
8. Any disruption of facility HVAC service shall be coordinated and scheduled with the West Virginia Lottery. A minimum 48 hour notice of such planned disruptions shall be provided to the West Virginia Lottery.

REQUEST FOR QUOTATION
Chiller Replacement

9. The contractor/vendor shall warrant all equipment that fail in materials or workmanship as follows:
- Compressors: Minimum of Six years from date of completion.
 - Parts: Minimum of Two years from date of completion.
 - Labor: Minimum of Two years from date of completion.

End of Exhibit B

WV-75
Created 07/18/12



State of West Virginia

PURCHASING DIVISION

Construction Bid Submission Review Form

This list has been provided for informational purposes only and is not to be construed as a complete list of request for quotation or bidding requirements for any individual construction project. This list does not and cannot include every item, mistake or oversight that could cause a contractor's bid to be disqualified. Rather, this list is intended to draw attention to some of the most common problems that the Purchasing Division encounters in the bidding process for construction projects. All potential bidders must read the request for quotation, all additional documents, and all instructions relating thereto ("Bid Documents") in their entirety to identify the actual request for quotation and bidding requirements. Failure to read the Bid Documents in their entirety and comply with the stated requirements contained therein may result in bid disqualification.

Errors That Shall Be Reason for Immediate Bid Disqualification

1. Failure to attend a mandatory pre-bid meeting
2. Failure to sign the bid
3. Failure to supply West Virginia contractor's license # on bid
4. Failure to supply a signed drug free workplace affidavit with the bid
5. Failure to supply a valid bid bond or other surety approved by the State of West Virginia
6. Failure to meet any mandatory requirement of the RFQ
7. Failure to acknowledge receipt of Addenda (only if stipulated as mandatory)
8. Failure to submit bid prior to the bid opening date and time
9. Federal debarment
10. State of West Virginia debarment or suspension

Errors that May Be Reason for Bid Disqualification Before Contract Award

1. Uncontested debt to the State exceeding \$1,000.00 (must be cured prior to award)
2. Workers' Compensation or Unemployment Compensation delinquency (must be cured prior to award)
3. Not registered as a vendor with the State (must be cured prior to award)
4. Failure to obtain required bonds and/or insurance
5. Failure to provide the sub-contractor listing within 1 business day of bid opening.
6. Failure to use the provided RFQ form (only if stipulated as mandatory).



**State of West Virginia
DRUG FREE WORKPLACE CONFORMANCE AFFIDAVIT
West Virginia Code §21-1D-5**

**STATE OF WEST VIRGINIA,
COUNTY OF Jackson, TO-WIT:**

I, Scott Danndol, after being first duly sworn, depose and state as follows:

1. I am an employee of Danndol Mechanical Inc; and,
(Company Name)
2. I do hereby attest that Danndol Mechanical Inc
(Company Name)

maintains a written plan for a drug-free workplace policy and that such plan and policy are in compliance with **West Virginia Code §21-1D.**

The above statements are sworn to under the penalty of perjury.

Printed Name: Scott Danndol
 Signature: Scott Danndol
 Title: Pres
 Company Name: Danndol Mechanical Inc
 Date: 2-23-2017

Taken, subscribed and sworn to before me this 23rd day of Feb, 2017.

By Commission expires Feb 13, 2022



R. Paige Ellis
(Notary Public)

THIS AFFIDAVIT MUST BE SUBMITTED WITH THE BID IN ORDER TO COMPLY WITH WV CODE PROVISIONS. FAILURE TO INCLUDE THE AFFIDAVIT WITH THE BID SHALL RESULT IN DISQUALIFICATION OF THE BID.

BID BOND PREPARATION INSTRUCTIONS

AGENCY (A) _____
RFQ/RFP# (B) _____

- (A) WV State Agency
(Stated on Page 1 "Spending Unit")
- (B) Request for Quotation Number (upper right corner of page #1)
- (C) Your Business Entity Name (or Individual Name if Sole Proprietor)
- (D) City, Location of your Company
- (E) State, Location of your Company
- (F) Surety Corporate Name
- (G) City, Location of Surety
- (H) State, Location of Surety
- (I) State of Surety Incorporation
- (J) City of Surety's Principal Office
- (K) Minimum amount of acceptable bid bond is 5% of total bid. You may state "5% of bid" or a specific amount on this line in words.
- (L) Amount of bond in numbers
- (M) Brief Description of scope of work
- (N) Day of the month
- (O) Month
- (P) Year
- (Q) Name of Business Entity (or Individual Name if Sole Proprietor)
- (R) Seal of Principal
- (S) Signature of President, Vice President, or Authorized Agent
- (T) Title of Person Signing for Principal
- (U) Seal of Surety
- (V) Name of Surety
- (W) Signature of Attorney in Fact of the Surety

Bid Bond

KNOW ALL MEN BY THESE PRESENTS, That we, the undersigned,
 _____ (C) of _____ (D) _____ (E)
 as Principal, and _____ (F) of _____ (G)
 _____ (H), a corporation organized and existing under the laws
 of the State of _____ (I) with its principal office in the City of
 _____ (J), as Surety, are held and firmly bound unto The State
 of West Virginia, as Obligee, in the penal sum of _____ (K)
 (\$ _____ (L)) for the payment of which, well and truly to be made,
 we jointly and severally bind ourselves, our heirs, administrators, executors,
 successors and assigns.

The Condition of the above obligation is such that whereas the Principal has submitted to the Purchasing Section of the Department of Administration a certain bid or proposal, attached hereto and made a part hereof to enter into a contract in writing for _____
 _____ (M)

NOW THEREFORE

(a) If said bid shall be rejected, or
 (b) If said bid shall be accepted and the Principal shall enter into a contract in accordance with the bid or proposal attached hereto and shall furnish any other bonds and insurance required by the bid or proposal, and shall in all other respects perform the agreement created by the acceptance of said bid then this obligation shall be null and void, otherwise this obligation shall remain in full force and effect. It is expressly understood and agreed that the liability of the Surety for any and all claims hereunder shall, in no event, exceed the penal amount of this obligation as herein stated

The Surety for value received, hereby stipulates and agrees that the obligations of said Surety and its bond shall be in no way impaired or affected by any extension of time within which the Obligee may accept such bid: and said Surety does hereby waive notice of any such extension.

WITNESS, the following signatures and seals of Principal and Surety, executed and sealed by a proper officer of Principal and Surety, or by Principal individually if Principal is an individual, the (N) day of (O), 20 (P).

Principal Seal _____ (Q)
 (Name of Principal)

(R) By _____ (S)
 (Must be President, Vice President, or
 Duly Authorized Agent)

_____ (T)
 Title

Surety Seal _____ (V)
 (Name of Surety)

_____ (W)
 Attorney-in-Fact

NOTE 1: Dated Power of Attorney with Surety Seal must accompany this bid bond.

IMPORTANT – Surety executing bonds must be licensed in West Virginia to transact surety insurance, must affix its seal, and must attach a power of attorney with its seal affixed.

Agency _____
REQ.P.O# _____

BID BOND

KNOW ALL MEN BY THESE PRESENTS, That we, the undersigned, _____
of _____, _____, as Principal, and _____
of _____, _____, a corporation organized and existing under the laws of the State of _____
with its principal office in the City of _____, as Surety, are held and firmly bound unto the State
of West Virginia, as Obligee, in the penal sum of _____ (\$ _____) for the payment of which,
well and truly to be made, we jointly and severally bind ourselves, our heirs, administrators, executors, successors and assigns.

The Condition of the above obligation is such that whereas the Principal has submitted to the Purchasing Section of the
Department of Administration a certain bid or proposal, attached hereto and made a part hereof, to enter into a contract in writing for

NOW THEREFORE,

- (a) If said bid shall be rejected, or
- (b) If said bid shall be accepted and the Principal shall enter into a contract in accordance with the bid or proposal
attached hereto and shall furnish any other bonds and insurance required by the bid or proposal, and shall in all other respects perform
the agreement created by the acceptance of said bid, then this obligation shall be null and void, otherwise this obligation shall remain in
full force and effect. It is expressly understood and agreed that the liability of the Surety for any and all claims hereunder shall, in no
event, exceed the penal amount of this obligation as herein stated.

The Surety, for the value received, hereby stipulates and agrees that the obligations of said Surety and its bond shall be in no
way impaired or affected by any extension of the time within which the Obligee may accept such bid, and said Surety does hereby
waive notice of any such extension.

WITNESS, the following signatures and seals of Principal and Surety, executed and sealed by a proper officer of Principal and
Surety, or by Principal individually if Principal is an individual, this _____ day of _____, 20 _____.

Principal Seal

(Name of Principal)

By _____
(Must be President, Vice President, or
Duly Authorized Agent)

(Title)

Surety Seal

(Name of Surety)

Attorney-in-Fact

**IMPORTANT – Surety executing bonds must be licensed in West Virginia to transact surety insurance, must affix its seal, and
must attach a power of attorney with its seal affixed.**

DESIGNATED CONTACT: Vendor appoints the individual identified in this Section as the Contract Administrator and the initial point of contact for matters relating to this Contract.

Scott Darnold Pres
 (Name, Title)
Scott Darnold Pres
 (Printed Name and Title)
PO Box 149 Kenna WV 25248
 (Address)
304-988-1618
 (Phone Number) / (Fax Number)
sdarnold@darnoldmech.com
 (email address)

CERTIFICATION AND SIGNATURE: By signing below, or submitting documentation through wvOASIS, I certify that I have reviewed this Solicitation in its entirety; that I understand the requirements, terms and conditions, and other information contained herein; that this bid, offer or proposal constitutes an offer to the State that cannot be unilaterally withdrawn; that the product or service proposed meets the mandatory requirements contained in the Solicitation for that product or service, unless otherwise stated herein; that the Vendor accepts the terms and conditions contained in the Solicitation, unless otherwise stated herein; that I am submitting this bid, offer or proposal for review and consideration; that I am authorized by the vendor to execute and submit this bid, offer, or proposal, or any documents related thereto on vendor's behalf; that I am authorized to bind the vendor in a contractual relationship; and that to the best of my knowledge, the vendor has properly registered with any State agency that may require registration.

Darnold Mechanical Inc.
 (Company)

Scott Darnold Pres
 (Authorized Signature) (Representative Name, Title)

Scott Darnold Pres
 (Printed Name and Title of Authorized Representative)

2-16-17
 (Date)

304-988-1618
 (Phone Number) (Fax Number)

STATE OF WEST VIRGINIA
Purchasing Division

PURCHASING AFFIDAVIT

MANDATE: Under W. Va. Code §5A-3-10a, no contract or renewal of any contract may be awarded by the state or any of its political subdivisions to any vendor or prospective vendor when the vendor or prospective vendor or a related party to the vendor or prospective vendor is a debtor and: (1) the debt owed is an amount greater than one thousand dollars in the aggregate; or (2) the debtor is in employer default.

EXCEPTION: The prohibition listed above does not apply where a vendor has contested any tax administered pursuant to chapter eleven of the W. Va. Code, workers' compensation premium, permit fee or environmental fee or assessment and the matter has not become final or where the vendor has entered into a payment plan or agreement and the vendor is not in default of any of the provisions of such plan or agreement.

DEFINITIONS:

"Debt" means any assessment, premium, penalty, fine, tax or other amount of money owed to the state or any of its political subdivisions because of a judgment, fine, permit violation, license assessment, defaulted workers' compensation premium, penalty or other assessment presently delinquent or due and required to be paid to the state or any of its political subdivisions, including any interest or additional penalties accrued thereon.

"Employer default" means having an outstanding balance or liability to the old fund or to the uninsured employers' fund or being in policy default, as defined in W. Va. Code § 23-2c-2, failure to maintain mandatory workers' compensation coverage, or failure to fully meet its obligations as a workers' compensation self-insured employer. An employer is not in employer default if it has entered into a repayment agreement with the Insurance Commissioner and remains in compliance with the obligations under the repayment agreement.

"Related party" means a party, whether an individual, corporation, partnership, association, limited liability company or any other form or business association or other entity whatsoever, related to any vendor by blood, marriage, ownership or contract through which the party has a relationship of ownership or other interest with the vendor so that the party will actually or by effect receive or control a portion of the benefit, profit or other consideration from performance of a vendor contract with the party receiving an amount that meets or exceed five percent of the total contract amount.

AFFIRMATION: By signing this form, the vendor's authorized signer affirms and acknowledges under penalty of law for false swearing (W. Va. Code §61-5-3) that neither vendor nor any related party owe a debt as defined above and that neither vendor nor any related party are in employer default as defined above, unless the debt or employer default is permitted under the exception above.

WITNESS THE FOLLOWING SIGNATURE:

Vendor's Name: Danhold Mechanical Inc

Authorized Signature: [Signature] Date: 2-23-17

State of West Virginia

County of Kanawha, to-wit:

Taken, subscribed, and sworn to before me this 23rd day of Feb, 2017.

My Commission expires Feb 13, 2022

AFFIX SEAL HERE

NOTARY PUBLIC [Signature]



ADDENDUM ACKNOWLEDGEMENT FORM
SOLICITATION NO.: _____

Instructions: Please acknowledge receipt of all addenda issued with this solicitation by completing this addendum acknowledgment form. Check the box next to each addendum received and sign below. Failure to acknowledge addenda may result in bid disqualification.

Acknowledgment: I hereby acknowledge receipt of the following addenda and have made the necessary revisions to my proposal, plans and/or specification, etc.

Addendum Numbers Received:

(Check the box next to each addendum received)

- | | |
|----------------------------------------------------|------------------------------------------|
| <input checked="" type="checkbox"/> Addendum No. 1 | <input type="checkbox"/> Addendum No. 6 |
| <input checked="" type="checkbox"/> Addendum No. 2 | <input type="checkbox"/> Addendum No. 7 |
| <input checked="" type="checkbox"/> Addendum No. 3 | <input type="checkbox"/> Addendum No. 8 |
| <input type="checkbox"/> Addendum No. 4 | <input type="checkbox"/> Addendum No. 9 |
| <input type="checkbox"/> Addendum No. 5 | <input type="checkbox"/> Addendum No. 10 |

I understand that failure to confirm the receipt of addenda may be cause for rejection of this bid. I further understand that any verbal representation made or assumed to be made during any oral discussion held between Vendor's representatives and any state personnel is not binding. Only the information issued in writing and added to the specifications by an official addendum is binding.

Dannold Mechanical Inc.
Company
Grant Dannold
Authorized Signature
2-16-17
Date

NOTE: This addendum acknowledgment should be submitted with the bid to expedite document processing.
Revised 6/8/2012

BID BOND

KNOW ALL MEN BY THESE PRESENTS, That we, the undersigned, Darnold Mechanical, Inc.
of Kenna, WV, as Principal, and The Ohio Casualty Insurance Company
of Boston, MA, a corporation organized and existing under the laws of the State of
NH with its principal office in the City of Boston, as Surety, are held and firmly bound unto the State
of West Virginia, as Obligee, in the penal sum of Five Percent of Amount Bid (\$ 5%) for the payment of which,
well and truly to be made, we jointly and severally bind ourselves, our heirs, administrators, executors, successors and assigns.

The Condition of the above obligation is such that whereas the Principal has submitted to the Purchasing Section of the
Department of Administration a certain bid or proposal, attached hereto and made a part hereof, to enter into a contract in writing for
Materials & Labor to Replace Chiller - WV Lottery, Charleston, WV

NOW THEREFORE,

- (a) If said bid shall be rejected, or
- (b) If said bid shall be accepted and the Principal shall enter into a contract in accordance with the bid or proposal
attached hereto and shall furnish any other bonds and insurance required by the bid or proposal, and shall in all other respects perform
the agreement created by the acceptance of said bid, then this obligation shall be null and void, otherwise this obligation shall remain in
full force and effect. It is expressly understood and agreed that the liability of the Surety for any and all claims hereunder shall, in no
event, exceed the penal amount of this obligation as herein stated.

The Surety, for the value received, hereby stipulates and agrees that the obligations of said Surety and its bond shall be in no
way impaired or affected by any extension of the time within which the Obligee may accept such bid, and said Surety does hereby
waive notice of any such extension.

WITNESS, the following signatures and seals of Principal and Surety, executed and sealed by a proper officer of Principal and
Surety, or by Principal individually if Principal is an individual, this 16th day of February, 2017.

Principal Seal

Darnold Mechanical, Inc.
(Name of Principal)
By: [Signature]
(Must be President, Vice President, or
Duly Authorized Agent)
Pres
(Title)

Surety Seal

The Ohio Casualty Insurance Company
(Name of Surety)
By: [Signature]
Kimberly L. Miles, Licensed WV Resident Agent **Attorney-in-Fact**

**IMPORTANT – Surety executing bonds must be licensed in West Virginia to transact surety insurance, must affix its seal, and
must attach a power of attorney with its seal affixed.**

THIS POWER OF ATTORNEY IS NOT VALID UNLESS IT IS PRINTED ON RED BACKGROUND.

This Power of Attorney limits the acts of those named herein, and they have no authority to bind the Company except in the manner and to the extent herein stated.

Certificate No. 7482318

American Fire and Casualty Company
The Ohio Casualty Insurance Company

Liberty Mutual Insurance Company
West American Insurance Company

POWER OF ATTORNEY

KNOWN ALL PERSONS BY THESE PRESENTS: That American Fire & Casualty Company and The Ohio Casualty Insurance Company are corporations duly organized under the laws of the State of New Hampshire, that Liberty Mutual Insurance Company is a corporation duly organized under the laws of the State of Massachusetts, and West American Insurance Company is a corporation duly organized under the laws of the State of Indiana (herein collectively called the "Companies"), pursuant to and by authority herein set forth, does hereby name, constitute and appoint, Andrew K. Teeler; Christopher A. Michel; Douglas P. Taylor; Jaime L. Carpenter; Kimberly L. Miles; Kimberly S. Burdette

all of the city of Charleston, state of WV each individually if there be more than one named, its true and lawful attorney-in-fact to make, execute, seal, acknowledge and deliver, for and on its behalf as surety and as its act and deed, any and all undertakings, bonds, recognizances and other surety obligations, in pursuance of these presents and shall be as binding upon the Companies as if they have been duly signed by the president and attested by the secretary of the Companies in their own proper persons

IN WITNESS WHEREOF, this Power of Attorney has been subscribed by an authorized officer or official of the Companies and the corporate seals of the Companies have been affixed thereto this 12th day of September, 2016

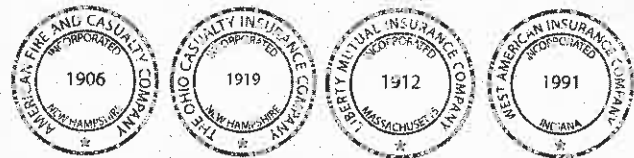

American Fire and Casualty Company
The Ohio Casualty Insurance Company
Liberty Mutual Insurance Company
West American Insurance Company

By: David M. Carey
David M. Carey, Assistant Secretary

STATE OF PENNSYLVANIA ss
COUNTY OF MONTGOMERY

On this 12th day of September, 2016, before me personally appeared David M. Carey, who acknowledged himself to be the Assistant Secretary of American Fire and Casualty Company, Liberty Mutual Insurance Company, The Ohio Casualty Insurance Company, and West American Insurance Company, and that he, as such, being authorized so to do, execute the foregoing instrument for the purposes therein contained by signing on behalf of the corporations by himself as a duly authorized officer.

IN WITNESS WHEREOF, I have hereunto subscribed my name and affixed my notarial seal at Plymouth Meeting, Pennsylvania, on the day and year first above written.



COMMONWEALTH OF PENNSYLVANIA
Notarial Seal
Teresa Pastella, Notary Public
Plymouth Twp., Montgomery County
My Commission Expires March 28, 2017
Member, Pennsylvania Association of Notaries

By: Teresa Pastella
Teresa Pastella, Notary Public

This Power of Attorney is made and executed pursuant to and by authority of the following By-laws and Authorizations of American Fire and Casualty Company, The Ohio Casualty Insurance Company, Liberty Mutual Insurance Company, and West American Insurance Company which resolutions are now in full force and effect reading as follows:

ARTICLE IV – OFFICERS – Section 12. Power of Attorney. Any officer or other official of the Corporation authorized for that purpose in writing by the Chairman or the President, and subject to such limitation as the Chairman or the President may prescribe, shall appoint such attorneys-in-fact, as may be necessary to act in behalf of the Corporation to make, execute, seal, acknowledge and deliver as surety any and all undertakings, bonds, recognizances and other surety obligations. Such attorneys-in-fact, subject to the limitations set forth in their respective powers of attorney, shall have full power to bind the Corporation by their signature and execution of any such instruments and to attach thereto the seal of the Corporation. When so executed, such instruments shall be as binding as if signed by the President and attested to by the Secretary. Any power or authority granted to any representative or attorney-in-fact under the provisions of this article may be revoked at any time by the Board, the Chairman, the President or by the officer or officers granting such power or authority.

ARTICLE XIII – Execution of Contracts – SECTION 5. Surety Bonds and Undertakings. Any officer of the Company authorized for that purpose in writing by the chairman or the president, and subject to such limitations as the chairman or the president may prescribe, shall appoint such attorneys-in-fact, as may be necessary to act in behalf of the Company to make, execute, seal, acknowledge and deliver as surety any and all undertakings, bonds, recognizances and other surety obligations. Such attorneys-in-fact subject to the limitations set forth in their respective powers of attorney, shall have full power to bind the Company by their signature and execution of any such instruments and to attach thereto the seal of the Company. When so executed such instruments shall be as binding as if signed by the president and attested by the secretary.

Certificate of Designation – The President of the Company, acting pursuant to the Bylaws of the Company, authorizes David M. Carey, Assistant Secretary to appoint such attorneys-in-fact as may be necessary to act on behalf of the Company to make, execute, seal, acknowledge and deliver as surety any and all undertakings, bonds, recognizances and other surety obligations.

Authorization – By unanimous consent of the Company's Board of Directors, the Company consents that facsimile or mechanically reproduced signature of any assistant secretary of the Company, wherever appearing upon a certified copy of any power of attorney issued by the Company in connection with surety bonds, shall be valid and binding upon the Company with the same force and effect as though manually affixed.

I, Gregory W. Davenport, the undersigned, Assistant Secretary, of American Fire and Casualty Company, The Ohio Casualty Insurance Company, Liberty Mutual Insurance Company, and West American Insurance Company do hereby certify that the original power of attorney of which the foregoing is a full, true and correct copy of the Power of Attorney executed by said Companies, is in full force and effect and has not been revoked.

IN TESTIMONY WHEREOF, I have hereunto set my hand and affixed the seals of said Companies this 16th day of February, 2017



By: Gregory W. Davenport
Gregory W. Davenport, Assistant Secretary

Not valid for mortgage, note, loan, letter of credit, currency rate, interest rate or residual value guarantees.

To confirm the validity of this Power of Attorney call 1-610-832-8240 between 9:00 am and 4:30 pm EST on any business day.

CONTRACTOR LICENSE

Authorized by the
West Virginia Contractor Licensing Board

Number: WV054588

Classification:

GENERAL BUILDING
HEATING, VENTILATING & COOLING
PLUMBING

DARNOLD MECHANICAL INC
DBA DARNOLD MECHANICAL INC
PO BOX 149
KENNA, WV 25248

Date Issued

Expiration Date

JANUARY 29, 2017

JANUARY 29, 2018

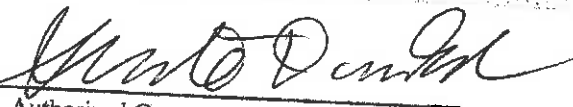
Authorized Company Signature

Chair, West Virginia Contractor
Licensing Board

WEST VIRGINIA
CONTRACTOR
LICENSING
BOARD

This license, or a copy thereof, must be posted in a conspicuous place at every construction site where work is being performed. This license number must appear in all advertisements, on all bid submissions and on all fully executed and binding contracts. This license cannot be assigned or transferred by licensee. Issued under provisions of West Virginia Code, Chapter 21, Article 11.



CERTIFICATE OF LIABILITY INSURANCE

DATE (MM/DD/YYYY)

2/02/2017

THIS CERTIFICATE IS ISSUED AS A MATTER OF INFORMATION ONLY AND CONFERS NO RIGHTS UPON THE CERTIFICATE HOLDER. THIS CERTIFICATE DOES NOT AFFIRMATIVELY OR NEGATIVELY AMEND, EXTEND OR ALTER THE COVERAGE AFFORDED BY THE POLICIES BELOW. THIS CERTIFICATE OF INSURANCE DOES NOT CONSTITUTE A CONTRACT BETWEEN THE ISSUING INSURER(S), AUTHORIZED REPRESENTATIVE OR PRODUCER, AND THE CERTIFICATE HOLDER.

IMPORTANT: If the certificate holder is an ADDITIONAL INSURED, the policy(ies) must be endorsed. If SUBROGATION IS WAIVED, subject to the terms and conditions of the policy, certain policies may require an endorsement. A statement on this certificate does not confer rights to the certificate holder in lieu of such endorsement(s).

PRODUCER USI Ins Svcs C/L Charleston 1 Hillcrest Drive East Charleston, WV 25311 304 347-0611	CONTACT NAME: Patty Mangus
	PHONE (A/C, No, Ext): 304-347-0774
	FAX (A/C, No):
	E-MAIL ADDRESS: patty.mangus@usi.com
	INSURER(S) AFFORDING COVERAGE
	INSURER A : State Auto Property & Casualty
	INSURER B : BrickStreet Mutual Insurance Co
	INSURER C :
	INSURER D :
	INSURER E :
	INSURER F :

INSURED	CERTIFICATE NUMBER:	REVISION NUMBER:
----------------	----------------------------	-------------------------

THIS IS TO CERTIFY THAT THE POLICIES OF INSURANCE LISTED BELOW HAVE BEEN ISSUED TO THE INSURED NAMED ABOVE FOR THE POLICY PERIOD INDICATED. NOTWITHSTANDING ANY REQUIREMENT, TERM OR CONDITION OF ANY CONTRACT OR OTHER DOCUMENT WITH RESPECT TO WHICH THIS CERTIFICATE MAY BE ISSUED OR MAY PERTAIN, THE INSURANCE AFFORDED BY THE POLICIES DESCRIBED HEREIN IS SUBJECT TO ALL THE TERMS, EXCLUSIONS AND CONDITIONS OF SUCH POLICIES. LIMITS SHOWN MAY HAVE BEEN REDUCED BY PAID CLAIMS.

INSR LTR	TYPE OF INSURANCE	ADDL INSR	SUBR WVD	POLICY NUMBER	POLICY EFF (MM/DD/YYYY)	POLICY EXP (MM/DD/YYYY)	LIMITS
A	<input checked="" type="checkbox"/> COMMERCIAL GENERAL LIABILITY <input type="checkbox"/> CLAIMS-MADE <input checked="" type="checkbox"/> OCCUR GEN'L AGGREGATE LIMIT APPLIES PER: <input type="checkbox"/> POLICY <input checked="" type="checkbox"/> PROJECT <input type="checkbox"/> LOC OTHER:			BOP287223902	01/29/2017	01/29/2018	EACH OCCURRENCE \$ 1,000,000 DAMAGE TO RENTED PREMISES (Ea occurrence) \$ 300,000 MED EXP (Any one person) \$ 5,000 PERSONAL & ADV INJURY \$ 1,000,000 GENERAL AGGREGATE \$ 2,000,000 PRODUCTS - COMP/OP AGG \$ 2,000,000 \$
A	AUTOMOBILE LIABILITY <input checked="" type="checkbox"/> ANY AUTO <input type="checkbox"/> ALL OWNED AUTOS <input type="checkbox"/> SCHEDULED AUTOS <input checked="" type="checkbox"/> HIRED AUTOS <input checked="" type="checkbox"/> NON-OWNED AUTOS			BAP243886202	02/22/2017	02/22/2018	COMBINED SINGLE LIMIT (Ea accident) \$ 1,000,000 BODILY INJURY (Per person) \$ BODILY INJURY (Per accident) \$ PROPERTY DAMAGE (Per accident) \$ \$
	UMBRELLA LIAB <input type="checkbox"/> OCCUR EXCESS LIAB <input type="checkbox"/> CLAIMS-MADE DED RETENTION \$						EACH OCCURRENCE \$ AGGREGATE \$ \$
B	WORKERS COMPENSATION AND EMPLOYERS' LIABILITY ANY PROPRIETOR/PARTNER/EXECUTIVE OFFICER/MEMBER EXCLUDED? <input checked="" type="checkbox"/> Y <input type="checkbox"/> N (Mandatory In NH) If yes, describe under DESCRIPTION OF OPERATIONS below		N/A	WCB1023460	01/29/2017	01/29/2018	<input checked="" type="checkbox"/> PER STATUTE <input type="checkbox"/> OTHER E.L. EACH ACCIDENT \$ 1,000,000 E.L. DISEASE - EA EMPLOYEE \$ 1,000,000 E.L. DISEASE - POLICY LIMIT \$ 1,000,000

DESCRIPTION OF OPERATIONS / LOCATIONS / VEHICLES (ACORD 101, Additional Remarks Schedule, may be attached if more space is required)

CERTIFICATE HOLDER	CANCELLATION
---------------------------	---------------------

Evidence of Insurance	SHOULD ANY OF THE ABOVE DESCRIBED POLICIES BE CANCELLED BEFORE THE EXPIRATION DATE THEREOF, NOTICE WILL BE DELIVERED IN ACCORDANCE WITH THE POLICY PROVISIONS.
	AUTHORIZED REPRESENTATIVE <i>Jamie P. Crouse</i>



SUBMITTAL DATA

for

W V Lottery - Chiller

Table of Contents

Technical Data Sheet for AGZ075E.....3
AGZ-E Clearance_Drawing for AGZ075E.....7
AGZ-E Close Spacing_Drawing for AGZ075E8
AGZ075-100E_CndGrl_PntBs_Drawing for AGZ075E12
AGZ075E_PKG_MCC_Drawing for AGZ075E.....13
FieldWiring_AGZE_SP_Drawing for AGZ075E.....14
IsoKit_RIS_332325101_Drawing for AGZ075E15

Technical Data Sheet for AGZ075E

Job Information		Technical Data Sheet
Job Name	W V Lottery - Chiller	
Date	2/22/2017	
Submitted By	Matt Duncan	
Software Version	07.20	
Unit Tag	AGZ075E	



Unit Overview						
Model Number	Capacity ton	IPLV/IP* EER	Voltage	Unit Starter Type	ASHRAE 90.1	LEED EA Credit 4
AGZ075E	71.80	17.40	460 / 60.0 / 3	Across the Line	'07, '10, '13	Pass

* IPLV reflects AHRI standard rating conditions and does not change with user defined conditions.

Unit			
Unit Type	Platform	Unit Revision	
Air-Cooled Scroll Compressor Chiller	High Efficiency Packaged	00	
Head Pressure	Tubing	VFD's w/o Line Reactors [High Efficiency]	
Unit Controls	Display	Replaceable Filter Dryer with Discharge & Liquid Valves, no HGBP	
Electronic Expansion Valve	On Controller only	Refrigerant Type	
R410A	Refrigerant Weight	92 lb (per unit)	
Pump Controls	Dual Evaporator Pumps - Dual Control Output		
Approval	ETL/cETL, AHRI & ASHRAE 90.1		
Evaporator	Water Volume: 7.9 gal		
Connection Hand:	Universal Connection - Facing out back		
Connection Size:	3.0 in		
Insulation:	Single Layer Insulation to Suction at each Compressor		

Entering Fluid Temperature	Leaving Fluid Temperature	Fluid Type	Glycol Concentration	Fluid Flow	Fluid Flow (with glycol) Min / Max	Pressure Drop	Fouling Factor
57.80 °F	44.00 °F	Water & Propylene	30.0 %	132.0 gpm	115.3 / 307.4 gpm	5.70 ft H ₂ O	0.000100 °F.ft ² .h/Btu

Note: Evaporator Pressure Drop includes strainer.

Condenser				
Coil Fins:	Guards:	Design Ambient Air Temperature	Altitude	Fan Diameter
MicroChannel	Condenser Coil Wire Grilles only	95.0 °F	0 ft	30.0 in
		Fan Motor Horsepower	Minimum Design Ambient Temperature	
		2.0 hp	35.0 °F	

Technical Data Sheet for AGZ075E

Unit Performance										
Design										
Capacity		Input Power		Efficiency		IPLV, IP*				
71.80 ton		79.80 kW		10.80 EER		17.40 EER				
Performance Points rated at AHRI Ambient Relief										
Point #	% Load	Unit Capacity ton	Input Power kW	Efficiency EER	Fluid Flow gpm	Evaporator			Condenser	
						Pressure Drop ft H ₂ O	Entering Fluid Temperature °F	Leaving Fluid Temperature °F	Ambient Air Temperature °F	Altitude ft
1	100.0	71.80	79.80	10.80	132.0	5.00	57.80	44.00	95.0	0
2	75.0	53.80	43.70	14.80	132.0	5.00	54.30	44.00	80.0	0
3	50.0	35.90	22.90	18.80	132.0	5.00	50.90	44.00	65.0	0
4	25.0	17.90	10.30	21.00	132.0	5.00	47.40	44.00	55.0	0

* IPLV reflects AHRI standard rating conditions and does not change with user defined conditions

Note: Evaporator Pressure Drop includes strainer.

Sound (without insulation)									
Sound Pressure (at 30 feet)									
63 Hz dB	125 Hz dB	250 Hz dB	500 Hz dB	1 kHz dB	2 kHz dB	4 kHz dB	8 kHz dB	Overall dBA	
68	68	68	62	60	54	49	44	65	
Sound Power									
63 Hz dB	125 Hz dB	250 Hz dB	500 Hz dB	1 kHz dB	2 kHz dB	4 kHz dB	8 kHz dB	Overall dBA	
95	95	95	89	87	81	76	71	92	

Octave band is non 'A' weighted and overall readings are 'A' weighted. Sound data rated in accordance with AHRI Standard-370.

Physical				
Unit				
Length*	Height	Width*	Shipping Weight*	Operating Weight*
150 in	99 in	88 in	4388 lb	4451 lb

* Shipping and operating weights do not include the weights of any Options or Accessories. Contact Chiller Applications for additional information.

Technical Data Sheet for AGZ075E

Electrical

Unit Electrical Data

Voltage	Starter Type	Fan Motor Quantity	LRA Fan Motor (each)	FLA Fan Motors (each)
460 / 60.0 / 3	Across the Line	6	18A	3.6A
Power Connection Type: Single Point Disconnect Switch with Circuit Protection				
Short Circuit Current Rating: 5 kA				
Phase Voltage: Phase & Under/Over Voltage Protection with LED				

Single Point Power Connection

MCA:	148.7 A
Fuse Size (recommended):	175 A
Fuse Size (maximum):	175 A
Connector Wire Range:	(1) 6-350

Compressor Electrical Data

Compressor Type	Compressor Quantity		Starter Type	
Scroll	4		Across the Line	
Circuit #:	1	3	2	4
Compressor #:	1	3	2	4
RLA:	30.8 A	30.8 A	26.9 A	30.8 A
Inrush Current:	229 A	229 A	173 A	229 A

Note: Power wiring connections to the chiller may be done with either copper or aluminum wiring. Wire should be sized per NEC and/or local codes. Wire sizing and wire count must fit in the power connection lug sizing listed in latest installation manual. Please contact your local sales office for more information.

Options

Basic Unit

Control Box Ambient: High Ambient with Exhaust Fans (125°F maximum)

Control

Communication: BACnet MS/TP

Electrical

Ground Fault: Unit Ground Fault Protection

Unit Options: 115V Convenience Outlet

Water Flow Indicator: With Factory Installed Strainer & Flow Indication (Thermal Dispersion)

Warranty

Unit Startup	By Others
Standard Warranty:	1st Year Entire Unit Parts plus Labor on Compressor
First Year Labor Warranty:	Parts & Labor
Extended Compressor Warranty:	Compressor Only; extended 4 years parts & labor

AHRI Certification



Certified in accordance with the AHRI Air-Cooled Water-Chilling Packages Using Vapor Compression Cycle Certification Program, which is based on AHRI Standard 550/590 (I-P) and AHRI Standard 551/591 (SI). Unit containing freeze protection fluids in the condenser or in the evaporator with a leaving chilled fluid temperature above 32°F [0°C] is certified when rated per the Standard with water. Certified units may be found in the AHRI Directory at www.ahridirectory.org.

Accessories

Optional

Part Number	Description
332325101	RIS Isolator Kit; AGZ: Packaged, Microchannel, Al&Cu Fins, 030-070E (non-Seismic), 25-65D, 30-65C; M'Chnl, 75-100E (non-S'mc); Al Fin, 70C/D; Remote, Al&Cu Fin, 30-70E (non-S'mc); Pump Pkg, M'Chnl&Al Fin, 30-65E (non-S'mic); Cu Fin, 30-55E (non-S'mic)



Intelligent Equipment®

There is no substitute

A whopping 40% of your building's energy expenses are tied to HVAC management. But most control solutions and building automation systems provide only limited insight into unit performance, hampering your ability to control that expense. Until now.

Intelligent Equipment from Daikin Applied gives you unprecedented visibility into your Daikin HVAC equipment. For less than it costs to run your smart phone, Intelligent Equipment provides direct access to 150 data points on a Daikin rooftop unit or chiller, all in real time. No other solution gives you the freedom and control to monitor and manage your equipment as deeply, freely, accurately, and efficiently. Not even a building automation system.

Intelligent Equipment is fully compatible with BAS; if you have a BAS, you can still benefit from Intelligent Equipment. But it's also unique: Intelligent Equipment is an equipment solution, not a building solution. By working at the unit level, IE provides several distinct benefits over a BAS, without expensive additional programming.

	Intelligent Equipment	Building Automation System
Preventative unit maintenance	Included	Not available
Unit Diagnostics	Notifies you of the exact issue	Limited to general alarm data points
Energy usage	Based on unit consumption	Requires a custom metering solution
Data storage	Unlimited	Limited to system memory capacity
Data trending	Trend any point back to unit start-up; decide what to trend at any point in lifecycle	Trend only the points in stored memory without custom programming; must decide what you want to trend before you can measure it
Data access	You have direct access and control who sees your data	BAS company has direct access
User interface	Designed to be easy to use	Most require skilled technicians to use
Cost	Plug and Play capability eliminates traditional BAS engineering, design, and installation costs	Requires higher costs for programming, design, and installation
Integration for new units	Pre-configured at factory and ready to turn on at commissioning; plug and play installation saves time and money, and allows equipment to be immediately accessed for start-up and commissioning.	Must be engineered at site during commissioning; access to data is not available during equipment startup and commissioning.
Unit-specific graphics	Pre-configured and matched to custom built equipment specifications.	Extensive programming and engineering time required to create unit-specific graphics.

**Contact us to get a free demonstration of Intelligent Equipment.
Get 90 days of free access, with your first year paid subscription.
Call 800-432-1342 today for a free demonstration.**

0A

AGZ-E Service Clearance

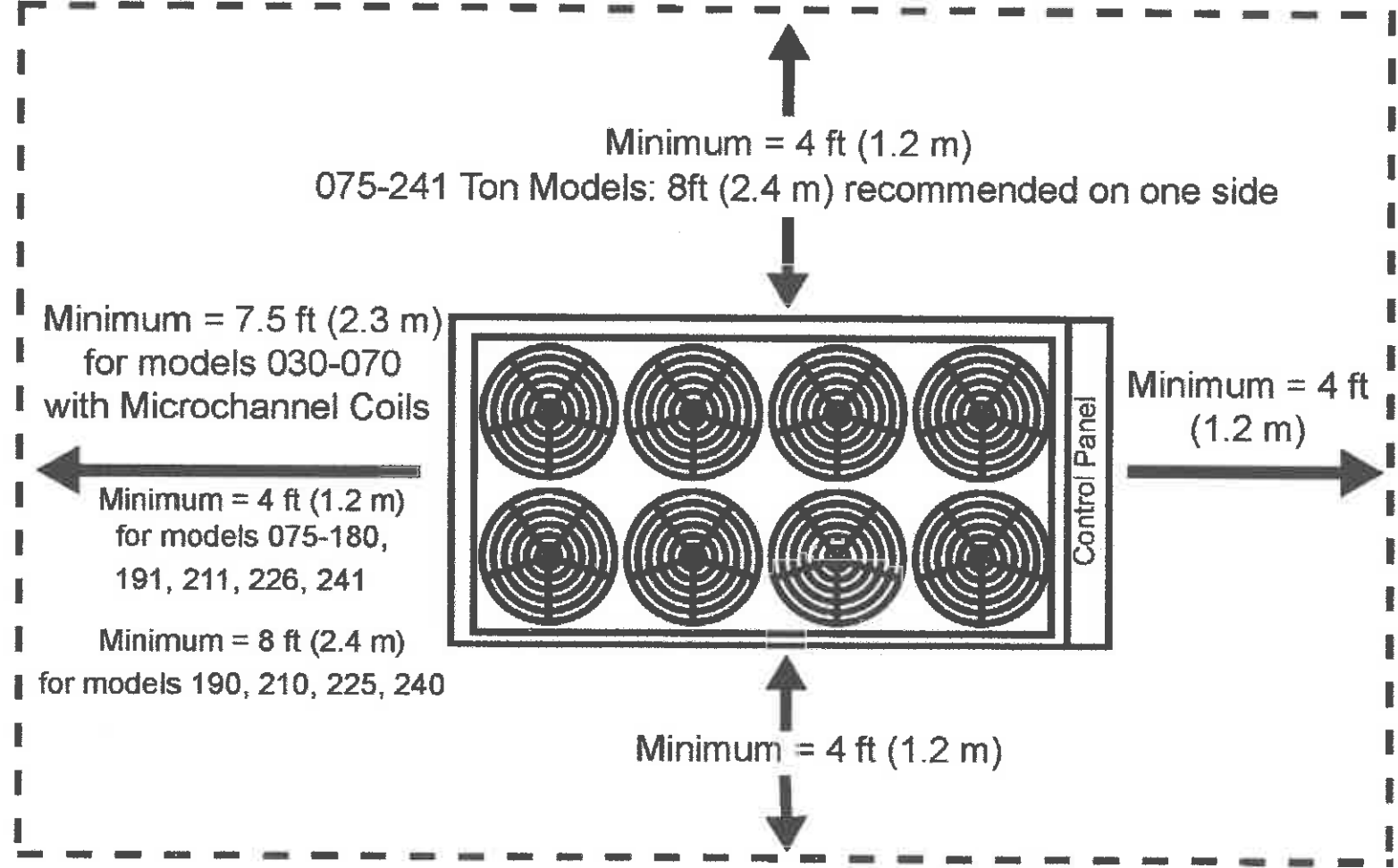

Job Number: XRA010
 Job Name: W V Lottery - Chiller
 Page 7 of 16
 Prepared Date: 2/22/2017
 www.DaikinApplied.com

Product Drawing		Unit Tag: AGZ075E		Sales Office: Mason & Barry, Inc.			 13600 Industrial Park Blvd. Minneapolis, MN 55441 www.DaikinApplied.com Software Version: 07.20
Product: Air-Cooled Scroll Chiller		Project Name: W V Lottery - Chiller		Sales Engineer: Scott Cowley			
Model: AGZ-E	Feb. 22, 2017	Ver/Rev:	Sheet: 1 of 1	Scale: NTS	Tolerance: +/- 1.0"	Dwg Units: in [mm]	
No change to this drawing may be made unless approved in writing by Daikin Applied. Purchaser must determine that the equipment is fit and sufficient for the job specifications.							

AGZ-E Close Spacing Performance

Case 1: Building or Wall on One Side of Unit

Assumes a solid height wall taller than unit. Refer to Case 4 for partial wall openings.

Building or Wall on One Side of Unit

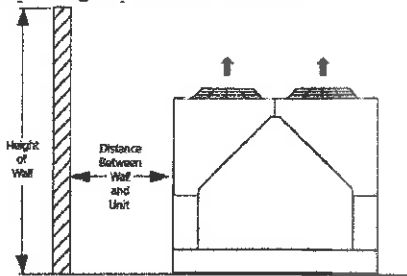

For models AGZ030-100E, maintain a 4 feet minimum from a wall of any height.

For models AGZ110-130E, maintain a 6 feet minimum from a wall of any height.

For models AGZ140-241E, maintain an 8 feet minimum from a wall of any height.

Case 2: Two Units, Side-by-Side

For models 030-180, there must be a minimum of 4 feet between two units placed side-by-side; however, performance may be affected at this distance. For models 190-211, the minimum is 6 feet as closing spacing may cause air recirculation and elevated condenser pressure. Assuming the requirement of one side having at least 8 feet of service clearance is met, Case 2 figures show performance adjustments as the distance between two units increases. Full Load Capacity Reduction

Two Units, Side-by-Side

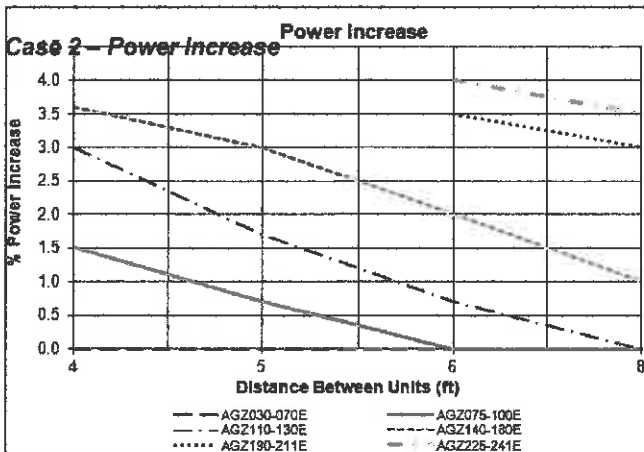
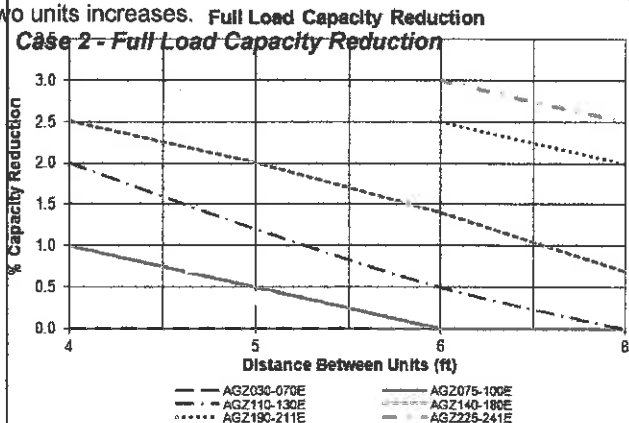
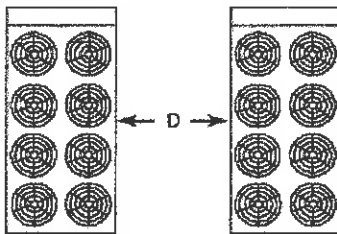

Product Drawing		Unit Tag: AGZ075E		 13600 Industrial Park Blvd. Minneapolis, MN 55441 www.DaikinApplied.com Software Version: 07.20		
Product: Air-Cooled Scroll Chiller		Project Name: W V Lottery - Chiller				
Model: AGZ-E		Sales Office: Mason & Barry, Inc.		Scale: NTS		Tolerance: +/-1.0"
Sales Engineer: Scott Cowley		Feb. 22, 2017	Ver/Rev:	Sheet 1 of 1	Dwg Units: in [mm]	
No change to this drawing may be made unless approved in writing by Daikin Applied. Purchaser must determine that the equipment is fit and sufficient for the job specifications.						

AGZ-E Close Spacing_Drawing for AGZ075E

Case 3: Three or More Units, Side-by-Side

For all models, there must be a minimum distance between any units placed side-by-side; however, performance may be affected at this distance. Minimum distances are: models 030 to 070 - 4 feet, models 075 to 100 - 5 feet, models 110 to 241 - 6 feet. The Case 3 charts below depict Case 3 performance adjustments as the distance between units increases. Data shown is for the middle unit with a unit on each side. See Case 2 adjustment factors for the two outside units.

Three or More Units, Side-by-Side

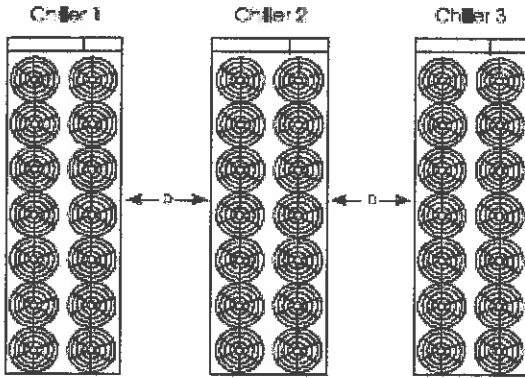

Case 3 – Full Load Capacity Reduction

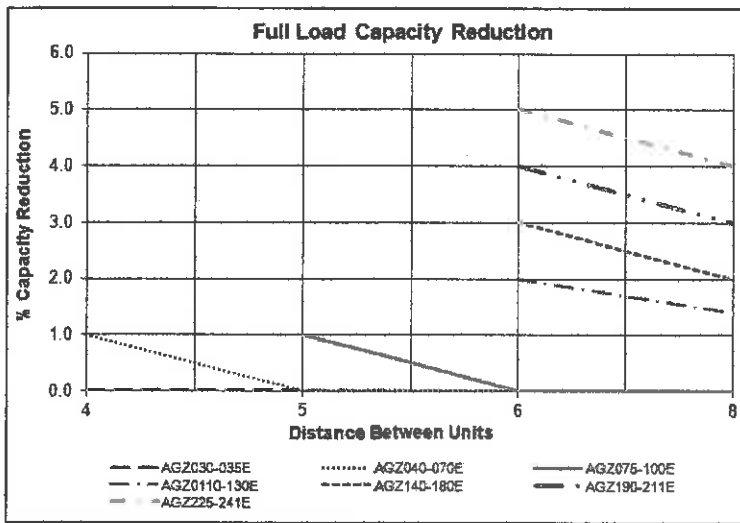

Case 3 – Power Increase

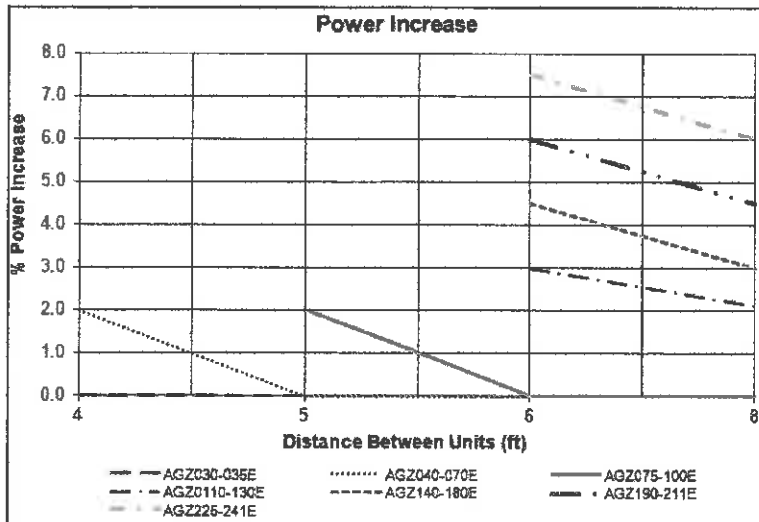

AGZ-E Close Spacing_Drawing for AGZ075E

Case 4: Open Screening Walls

Decorative screening walls are often used to help conceal a unit either on grade or on a rooftop. When possible, design these walls such that the combination of their open area and distance from the unit (see chart below) do not require performance adjustment. If the wall opening percentage is less than recommended for the distance to the unit, it should be considered as a solid wall. It is assumed that the wall height is equal to or less than the unit height when mounted on its base support. If the wall height is greater than the unit height, see Case 5: Pit Installation for performance adjustment factors. The distance from the sides of the unit to the side walls must be sufficient for service, such as opening control panel doors. For uneven wall spacing, the distance from the unit to each wall can be averaged providing no distance is less than 4 feet. Values are based on walls on all four sides.

Case 4 - Allowable Wall Open Area

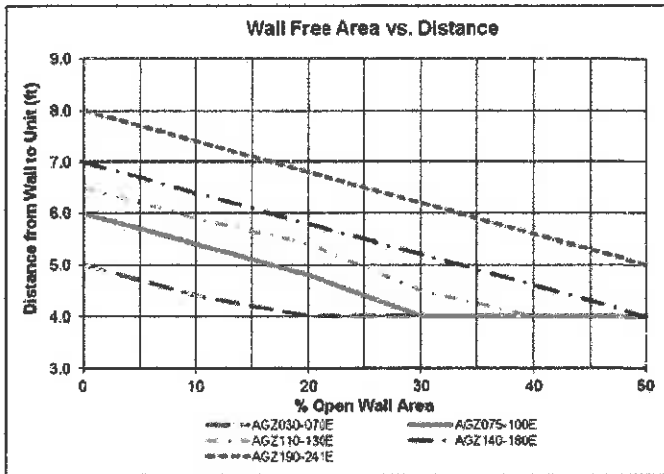

recirculation and restriction and require care that sufficient air clearance is maintained. A solid wall surrounding a unit is substantially a pit and this data should

Steel grating is sometimes used to cover a pit to prevent accidental falls or trips into the pit. The grating material and installation design must be strong enough to prevent such accidents, yet provide abundant open area to avoid recirculation problems. Have any pit installation reviewed by the Daikin Applied sales representative prior to installation to ensure it has sufficient air-flow characteristics and approved by the installation design engineer to avoid risk of accident.

Models AGZ030-070E:

The Case 5 figures for models AGZ030-070E show adjustment factors for pit/wall heights of 4 feet, 5 feet, and 6 feet.

Case 5 - Full Load Capacity Reduction and Power Increase (AGZ030E-070E)

Case 5 - Pit Installation

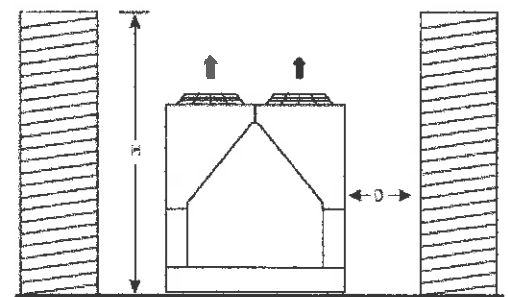
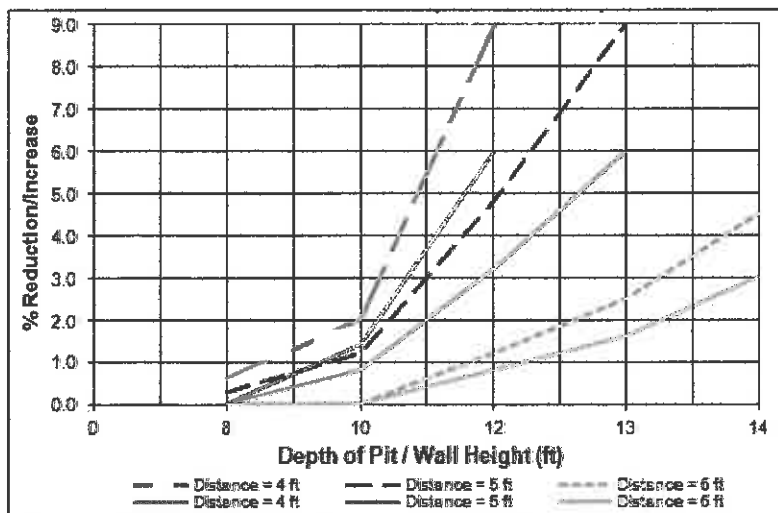

KEY:
 - - - - - : Power Increase
 _____ : Capacity Reduction

AGZ-E Close Spacing_Drawing for AGZ075E

Models AGZ075-130E:

The Case 5 figures for models AGZ075-130E show adjustment factors for pit/wall heights of 5 feet, 6 feet, and 8 feet.

Case 5 - Full Load Capacity Reduction and Power Increase (AGZ075-130E)

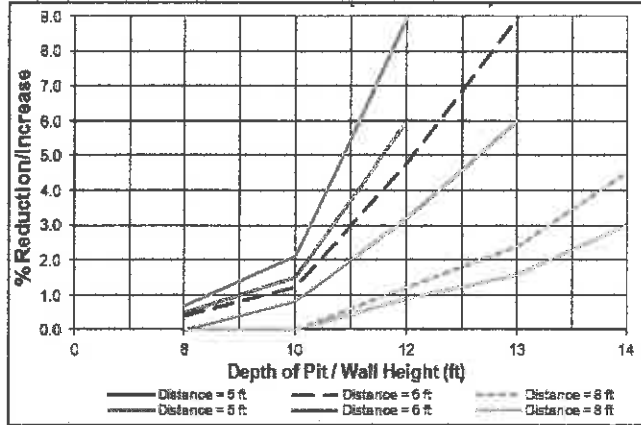

KEY:

----- : Power Increase
 _____ : Capacity Reduction

Models AGZ140-241E:

The Case 5 figures for models AGZ140-241E show adjustment factors for pit/wall heights of 6 feet, 8 feet, and 10 feet.

Case 5 - Full Load Capacity Reduction (AGZ140-180E)

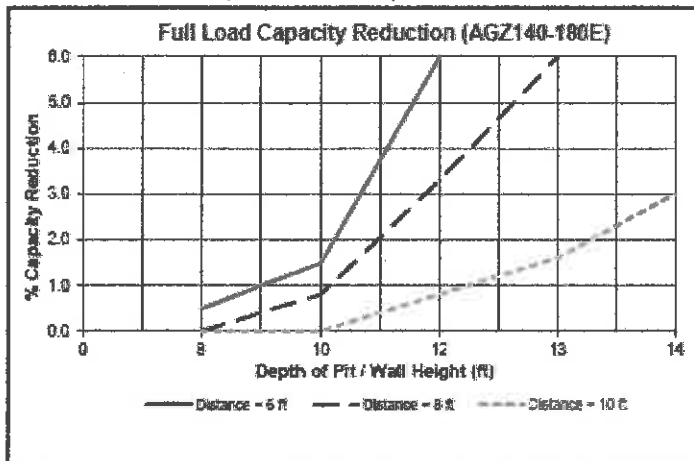

Case 5 - Power Increase (AGZ140-211E)

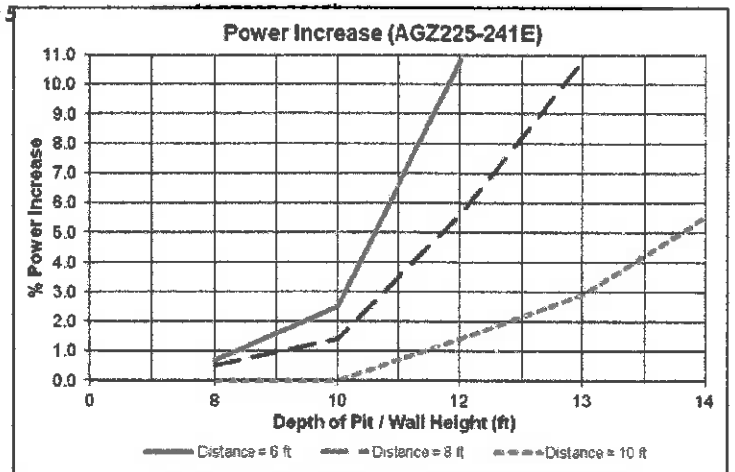
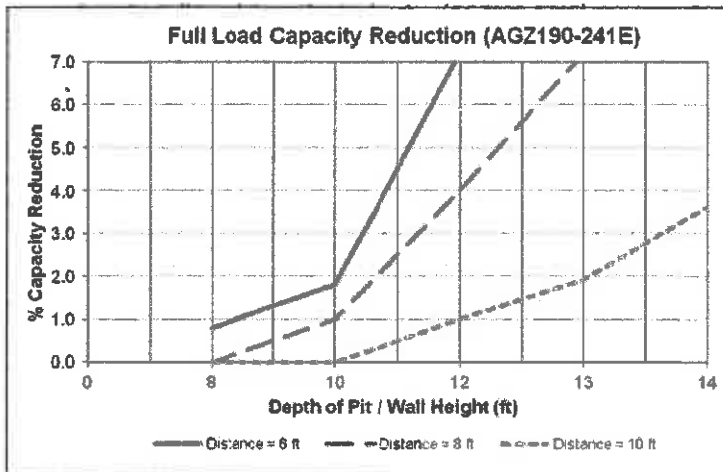
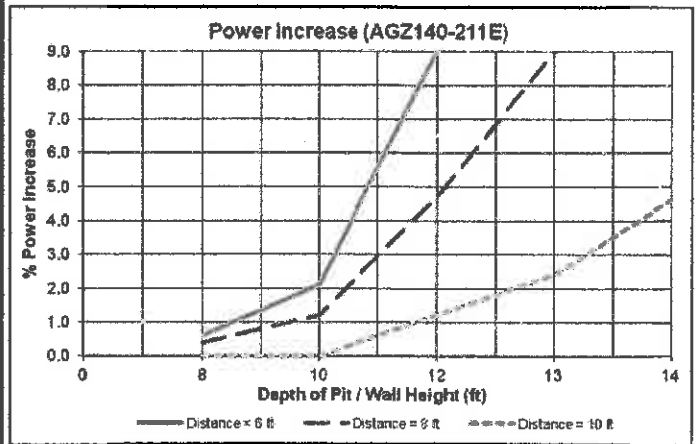

AGZ-E Guards: Condenser Coil Wire Grilles, Painted Base

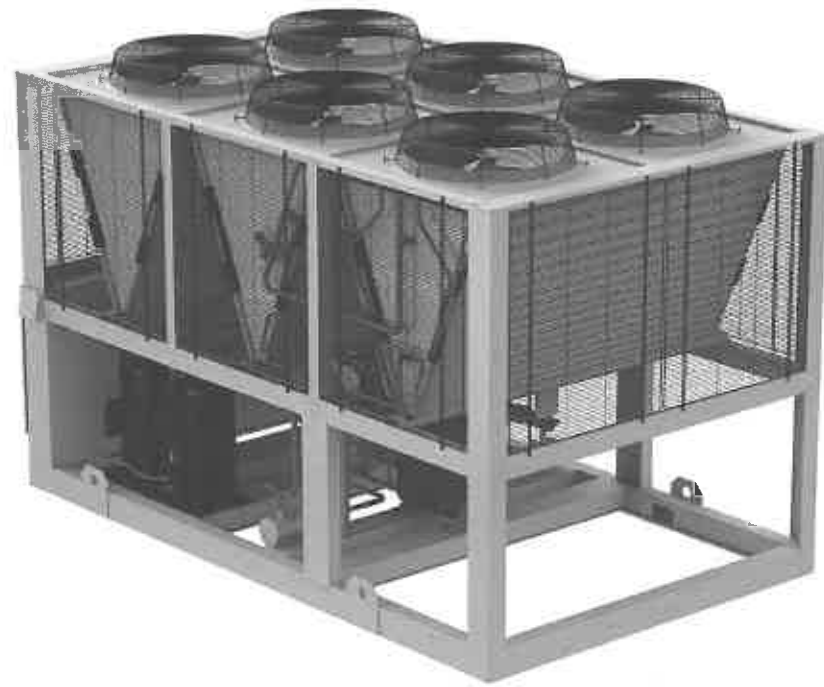
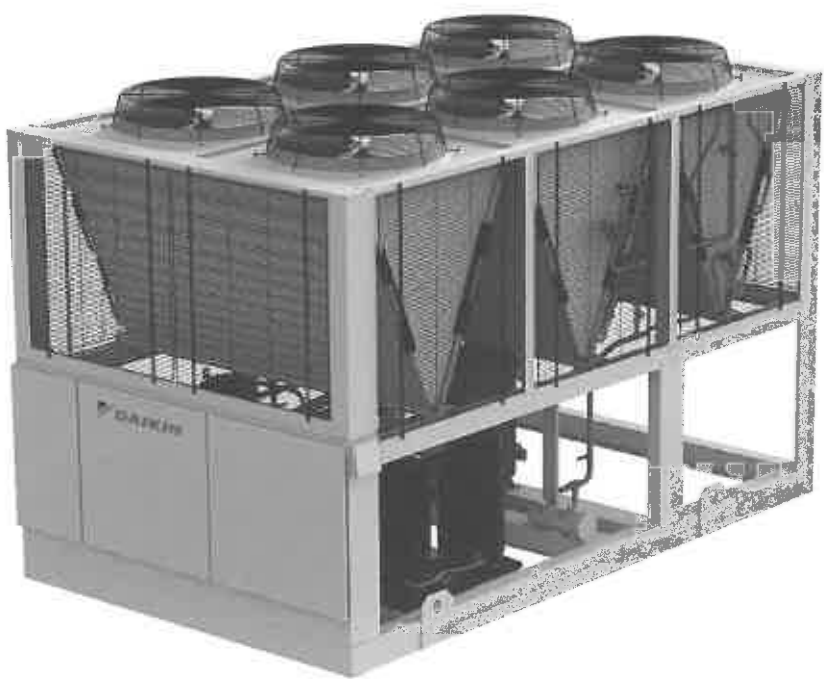



Diagram Notes
 Diagram simulates wrap, grille and louver options as selected only. Refrigeration components may vary depending on selected options.

Job Number: XRA010
 Job Name: W V Lottery - Chiller
 Page 12 of 16
 Prepared Date: 2/22/2017
 www.DaikinApplied.com

Product Drawing		Unit Tag: AGZ075E		Sales Office: Mason & Barry, Inc.			 13600 Industrial Park Blvd. Minneapolis, MN 55441 www.DaikinApplied.com Software Version: 07.20
Product: Air-Cooled Scroll Chiller		Project Name: W V Lottery - Chiller		Sales Engineer: Scott Cowley			
Model: AGZ075-100E	Feb. 22, 2017	Ver/Rev:	Sheet: 1 of 1	Scale: N/A	Tolerance: N/A	Dwg Units: N/A	
No change to this drawing may be made unless approved in writing by Daikin Applied. Purchaser must determine that the equipment is fit and sufficient for the job specifications.							

AGZ075E Packaged (Microchannel Condenser)

Job Number: XRA010
 Job Name: W V Lottery - Chiller
 Page 13 of 16
 Prepared Date: 2/22/2017
 www.DaikinApplied.com

M1 - M4, ISOLATOR MOUNTING HOLE LOCATIONS ON BOTTOM SURFACE OF UNIT BASE.

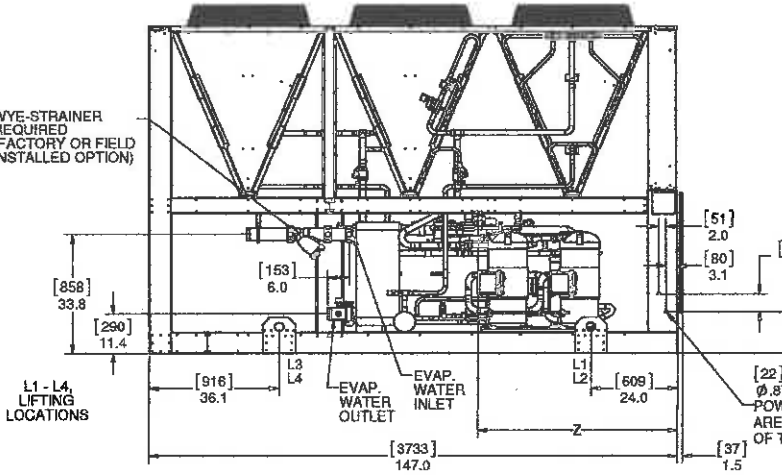
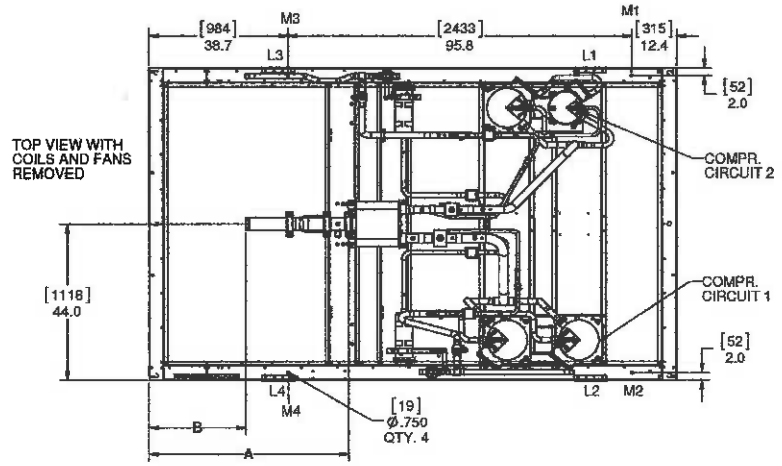

Unit Weight Data										
Units	Weight		Lifting Weight				Mounting Weight			
	Shipping	Operating	L1	L2	L3	L4	M1	M2	M3	M4
lb	4388	4451	1341	1420	790	837	1173	1242	989	1047
kg	1990	2019	608	644	358	380	532	563	449	475

Unit and Center of Gravity Dimensions						
Units	A (No Strainer)	B (With Strainer)	Connection Size (Victaulic)	Center of Gravity		
				X	Y	Z
in	55.6	27.1	3.0	45.3	38.6	56.2
mm	1412	688	76	1151	980	1427

NOTE
IT IS RECOMMENDED THAT THE SIDE LOCATIONS BE USED FOR POWER ENTRY WIRE SIZES LARGER THAN 350 MCM.

NOTE
A water strainer must be installed at the inlet of the evaporator to protect it from damage. Please refer to the IOM for additional details.

Product Drawing	Unit Tag: AGZ075E	Sales Office: Mason & Barry, Inc.					
Product: Air-Cooled Scroll Chiller	Project Name: W V Lottery - Chiller	Sales Engineer: Scott Cowley					
Model: AGZ075E	Feb. 22, 2017	Ver/Rev:	Sheet: 1 of 1	Scale: NTS	Tolerance: +/- 1.0"	Dwg Units: in [mm]	13600 Industrial Park Blvd. Minneapolis, MN 55441 www.DaikinApplied.com Software Version: 07.20

No change to this drawing may be made unless approved in writing by Daikin Applied. Purchaser must determine that the equipment is fit and sufficient for the job specifications.

AGZ030-241E Single-Point Connection Field Wiring Diagram

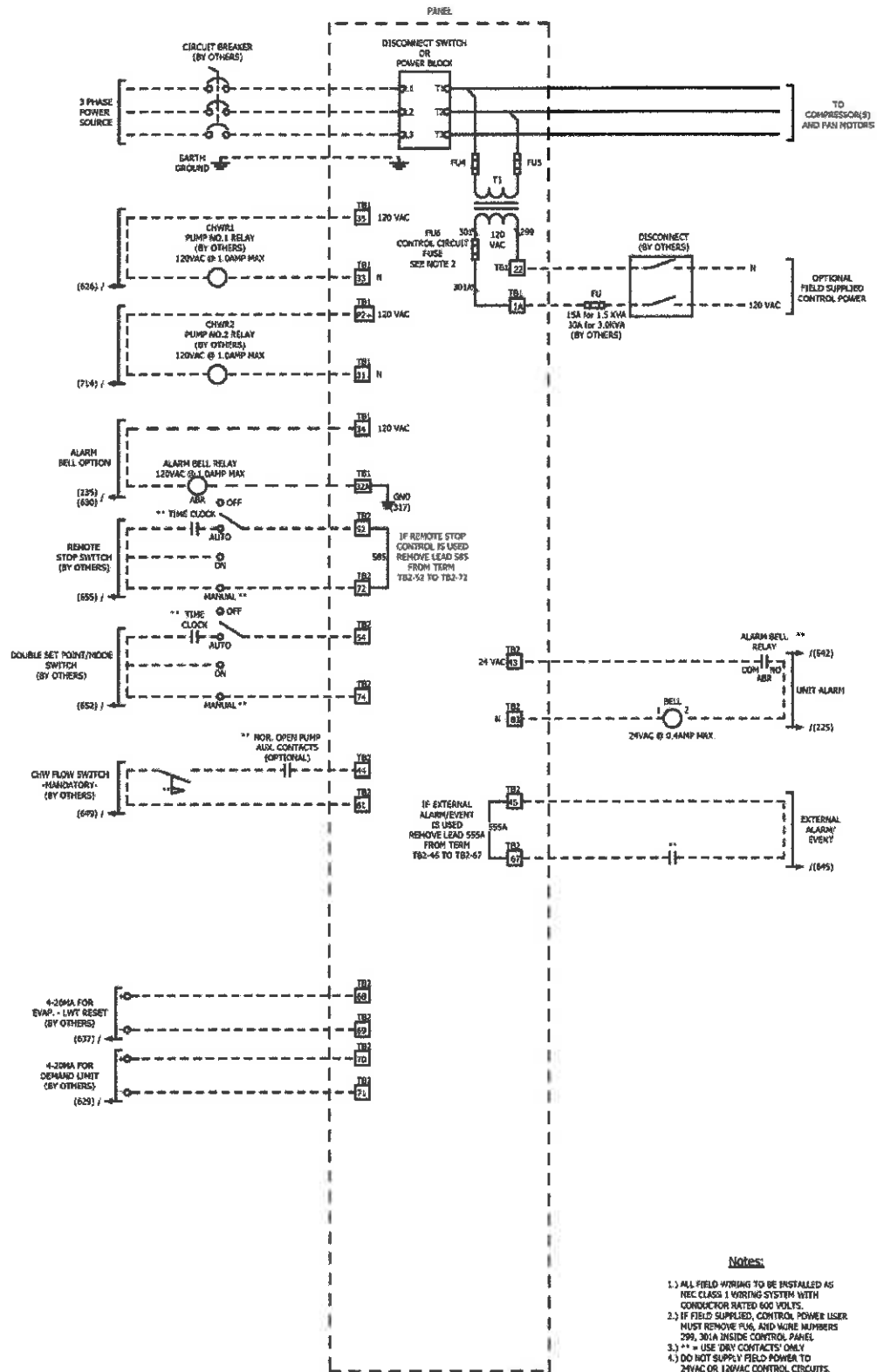

Notes:

- 1.) ALL FIELD WIRING TO BE INSTALLED AS NEC CLASS 1 WIRING SYSTEM WITH CONDUCTOR RATED 600 VOLTS.
- 2.) IF FIELD SUPPLIED CONTROL POWER USER MUST REMOVE FUSE AND WIRE NUMBERS 299, 301A INSIDE CONTROL PANEL
- 3.) ** = USE DRY CONTACTS ONLY
- 4.) DO NOT SUPPLY FIELD POWER TO 24VAC OR 120VAC CONTROL CIRCUITS.

Field Wiring Diagram		Unit Tag: AGZ075E		 13600 Industrial Park Blvd. Minneapolis, MN 55441 www.DaikinApplied.com Software Version: D7.20		
Product: Air-Cooled Scroll		Project Name: W V Lottery - Chiller				
Model: AGZ030-241E Single-Point		Sales Office: Mason & Barry, Inc.		Scale: N/A	Tolerance: N/A	Dwg Units: N/A
Sales Engineer: Scott Cowley		Feb. 22, 2017	Ver/Rev:	Sheet 1 of 1		

No change to this drawing may be made unless approved in writing by Daikin Applied. Purchaser must determine that the equipment is fit and sufficient for the job specifications.

Rubber-in-Shear (RIS) Isolator Kit

Dimension

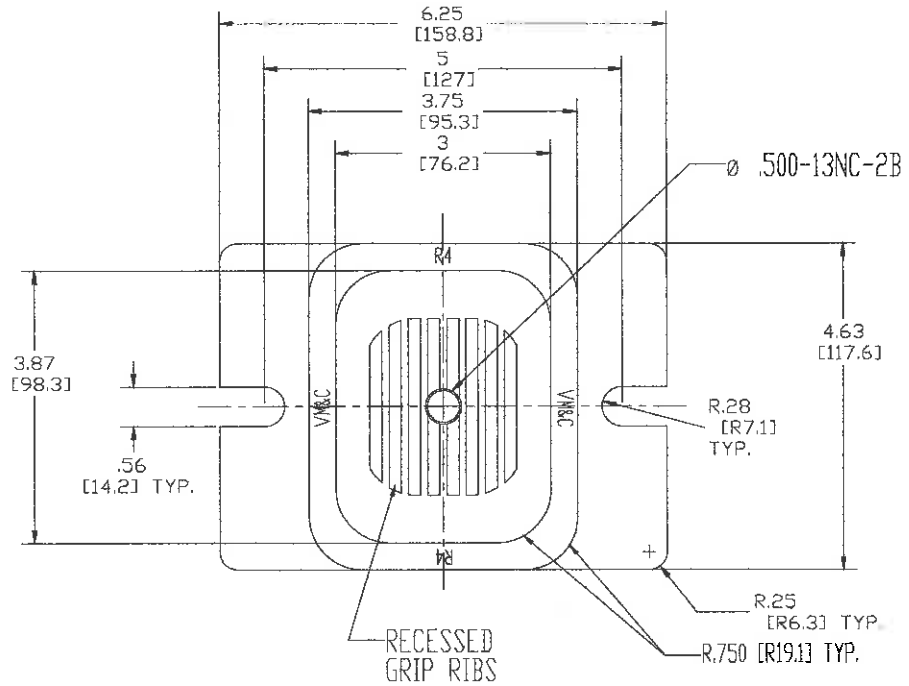

Mounting Location			
M1	M2	M3	M4
Brown	Brown	Brown	Brown

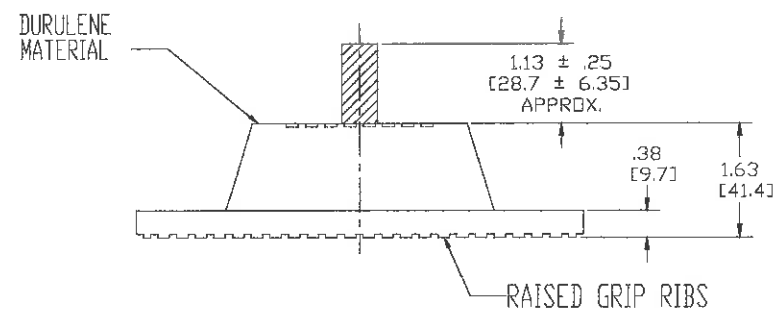
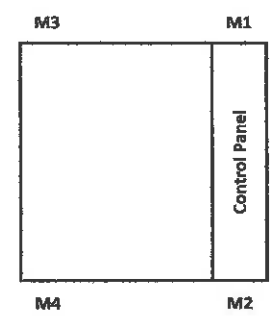

Job Number: XRA010
Job Name: W V Lottery - Chiller

Page 15 of 16

Prepared Date:

2/22/2017
www.DaikinApplied.com

Product Drawing		Unit Tag: AGZ075E		Sales Office: Mason & Barry, Inc.		 13600 Industrial Park Blvd. Minneapolis, MN 55441 www.DaikinApplied.com Software Version: 07.20
Accessory: Rubber-in-Shear (RIS) Isolator Kit		Project Name: W V Lottery - Chiller		Sales Engineer: Scott Cowley		
Kit Part Number: 332325101	Feb. 22, 2017	Ver/Rev:	Sheet: 1 of 1	Scale: NTS	Tolerance: +/- 1.0"	
No change to this drawing may be made unless approved in writing by Daikin Applied. Purchaser must determine that the equipment is fit and sufficient for the job specifications.						