

West Virginia Department of Health and Human Resources



CEOI 0506 HHR1700000001

**Hopemont Hospital Boilers &
Mildred Mitchell-Bateman Hospital Generator**

08/26/16 10:12:21
WV Purchasing Division



McKINLEY & ASSOCIATES
ARCHITECTS • ENGINEERS • INTERIOR DESIGN



August 25, 2016

Jessica S. Chambers
Senior Buyer
Department of Administration, Purchasing Division
2019 Washington Street, East
Charleston, WV 25305-0130

Dear Ms. Chambers and Members of the Selection Team,

McKinley & Associates is pleased to provide the West Virginia Department of Health and Human Resources with our Expression of Interest for professional engineering services for the design of replacement boilers systems located at Hopemont Hospital (Project A), as well as for transfer switches and other necessary components to fully utilize the existing emergency generator located at Mildred Mitchell-Bateman Hospital (Project B). By virtue of our multiple-office locations, including both northern (Wheeling, WV and Washington, PA) and southern (Charleston, WV) offices, we can respond to your 2 projects expeditiously. As you review this submission, we emphasize the following strengths of McKinley & Associates with respect to your projects:

McKinley & Associates has been providing design services since 1981. We support a professional staff of **MEP Engineers, Architects, a Qualified Commissioning Process Provider, a Historic Preservationist, LEED Accredited Professionals** specializing in Building Design and Construction, an Interior Designer, and Construction Administrators among others. We recently became a 100% ESOP Company (Employee Stock Ownership Plan), **so our employees now own 100% of our corporation!**

You will see in our submittal that we have **vast experience with similar projects**, which can be found under the “*Projects*” tab. This related experience includes work on hospitals, medical centers, VAMCs, several counties’ health departments, care facilities, rehabilitation centers, health care training facilities (such as West Virginia Northern Community College’s Education Center which houses a Surgical Technology Lab, Nursing Arts Lab, Respiratory Therapy Lab, and 4 more Health and Science labs), school based health centers, governmental/federal projects, and other relevant facilities. We have also designed a few projects for the **West Virginia DHHR**, which includes the new Ohio County office fit-out project, their offices within Building 34: West Virginia State Office Complex in Weirton, and their offices within Building 55: West Virginia State Office Complex in Logan (a **LEED Certified** project).

We have vast experience with **Federally Funded projects**, and we currently have Indefinite Delivery/Indefinite Quantity (IDIQ) Term Contract for Full Architectural/Engineering Design Services for a Federal Agency (the United States Postal Service). In addition to the USPS, we have also worked with the DOD, VA, FAA, HUD, EPA, MSHA, NASA, and NPS among others. We have also worked with multiple State government agencies, such as the DRS, DOE, DOC, DOJS, DOT, WVARNG, WVSP, and more. We are able to respond to their needs, and we are certain that we are able to respond to all of your needs as well.

Furthermore, we have designed **boiler replacements** in dozens of buildings across West Virginia and other States. This includes multiple projects for the United States Postal Service in both WV and PA. In addition, our Qualified Commissioning Process Provider has been formally trained to fully understand how integrated boiler/HVAC systems function and how systems interface with others to run your building efficiently. He understands that the boiler systems' performance can reduce operating and maintenance costs, improve the comfort of a building's occupants, and extend the life of equipment.

Moreover, McKinley & Associates has a wide array of relevant **generator upgrade** projects. Some of these include multiple West Virginia State Police projects across the State, Ohio County Correctional Facility, Wheeling Island Hotel•Casino•Racetrack, multiple West Virginia University projects, and several schools around the State, among others. Our generators range from a small 20 kW propane generator for a fire department building, to a 500 kW diesel generator for a 1.2 million SF distribution warehouse.

One of the more exciting aspects of our job is **listening to you**, our client, in how you envision this project, and transforming your ideas into realities. This can only be accomplished by effectively working together with you. Most of our current clients have been with our firm for many years. The main reason we have been able to maintain this relationship is because **we listen to their needs**. We encourage you to speak with our references because we feel this is the best way that our abilities can be conveyed to you.

We are ready to begin immediately and will meet all your Goals and Objectives. Thank you for reviewing our submission and considering McKinley & Associates for your project; we are very excited about the possibility of working with the West Virginia Department of Health and Human Resources again!

Sincerely,



Ernest Dellatorre
President

McKinley & Associates

304-233-0140

edellatorre@mckinleyassoc.com



McKINLEY & ASSOCIATES
ARCHITECTS • ENGINEERS • INTERIOR DESIGN

Corporate Information

Firm History

Founded in 1981, McKinley & Associates is a multi-discipline full service Architectural & Engineering firm, offering comprehensive professional services in Architecture, Engineering, Interior Design, LEED Design, Commissioning, Planning, and Construction Administration. We have a broad range of skill and experience for projects involving medical, wellness, governmental, educational, commercial, manufacturing, industrial, distribution, and much more. McKinley & Associates is a **100% ESOP Company** (Employee Stock Ownership Plan), which is a benefit plan that gives our employees 100% ownership of stock in our company. This is a contribution to the employee, not an employee purchase.



Charleston Enterprise Center - McKinley & Associates' Charleston, WV Office

Washington Trust Building



McKinley & Associates' Washington, PA Office

Firm Information

Ernest Dellatorre
President

Tim Mizer, PE, RA, QCxP
Director of Operations

Gregg Dorfner, AIA, NCARB
Director of Architecture

Date of Incorporation

July 1, 1981
Wheeling, West Virginia

Number of Professionals

Total Size	30
Architects	6
Engineers	3
Construction Admins.	3
Arch./Eng. Designers	9
Interior Designer	1
LEED AP BD+C	2
ALEP (CEFP) / REFP	2
Commissioning Provider	1
Historic Preservationist	1
MIS	1

Locations

The Maxwell Centre

Thirty-Two - Twentieth Street
Suite 100
Wheeling, West Virginia 26003
P: 304-233-0140
F: 304-233-4613

www.McKinleyAssoc.com
www.Facebook.com/McKinleyAssoc



Credentials

McKinley & Associates is a member of the following organizations:
CEFP, AWI, WVEDC, AIA, NFPA, NCARB, ASCE, ASPE, BOCA, ASHRAE, ACI International

Charleston Enterprise Center

1116 Smith Street
Suite 406
Charleston, West Virginia 25301
P: 304-340-4267
F: 304-340-4269

Washington Trust Building

6 S. Main Street
Suite 1028
Washington, Pennsylvania 15301
P: 724-223-8250
F: 724-223-8252

The Maxwell Centre - McKinley & Associates' Wheeling, WV Office



McKINLEY & ASSOCIATES
ARCHITECTS • ENGINEERS • INTERIOR DESIGN

Project Approach

First and foremost we can state that our large professional staff will devote whatever time is necessary to provide you with successful projects. If our project team is chosen for this project; they are available to **start immediately** upon our being selected, and will provide the necessary hours to complete your project on time.

To start your project, a kickoff meeting will be held with the Department of Health and Human Resources, the Hopemont Hospital and Mildred Mitchell-Bateman Hospital representatives, along with all our design professionals. From this meeting the Owners Project Requirements will be defined and documented, to be used as a guideline through the design phase. After this, **we will go on-site to the 2 hospitals, and verify the existing conditions of the facilities through the review of the existing conditions, existing drawings if available, and with discussions with the Owner.** We will then use all this information to design and specify new equipment and HVAC systems to better fit the standards of design today, and complete plans to install systems to fully utilize the generator.

Over the years, McKinley & Associates has designed **hundreds of projects which involve boiler/HVAC renovations, replacements, upgrades, and/or repairs.** During this time our expertise has been called upon many times upgrading outdated machinery, bringing the systems and load requirements up to compliance, and even evaluating and correcting errors in existing design. Additionally, years ago the United States Postal Service made commissioning a requirement on all boiler/HVAC projects; **therefore, your project manager, Tim E. Mizer, PE, RA, QCxP, became a Qualified Commissioning Process Provider.** From this, we commission multiple projects to ensure everything is working properly, and to teach the maintenance personnel how to use the machinery and gives them all the correct manuals. McKinley & Associates can work with the Contractors and Testing Adjusting & Balancing Company to verify proper system operation. The purpose of the verification is to verify all systems and equipment are operating as intended, and to the designed efficiency.

Our portfolio **also** includes many projects that involve **generators**, electrical, load requirements, emergency power systems, uninterruptible power supply (UPS), and much more. **Darren S. Duskey, PE**, our Electrical Engineer, has experience with a wide array of generators and emergency power systems projects, from a small 20 kW propane generator for a fire department building, to a 500 kW diesel generator for a 1.2 million SF distribution warehouse.

With our **vast HVAC renovation experience, generator and emergency power systems experience, understanding of codes, and our great working relationship with various state agencies;** we are confident that we have the talent and technology needed to make this successful. Also, as your **MEP Engineers/Architects and single point of responsibility,** you can be reassured of **smooth project delivery and sensitivity to all relevant guidelines in our state. We will meet your goals and objectives.**

The West Virginia State Police is one of our governmental clients that we have worked with for over 20 years on numerous projects throughout the state. We have designed **multiple boiler/HVAC renovations,** and multiple facilities have **generators,** especially the detachments with E-911 Centers, as well as the WVSP Headquarters.

We currently support clients on a number of significant renovation / upgrade projects, and have significant experience with renovation projects divided into multiple **Phases.** If we have to sequence/phase the new installations, say for example, **as to not disrupt the current occupants of the buildings, to allow concurrent occupation and use of the structure,** and/or for maintaining existing heating or cooling through the respective season; we have vast experience with phasing from our hundreds of renovation projects, and will coordinate your renovations as required.

Our philosophy regarding these types of work requires an intimate knowledge of the building so we can determine how to most effectively use the existing resources. Early activity includes carefully mapping out any damaged areas and formulating a plan of action for repairs, and helps us to determine the present inadequacies with the electrical systems and load requirements. This process targets the areas of greatest need and helps to control cost. It is with this experience that we are able to bring insight to the design of spaces that will retain long term value. **We can and will perform for you on time and to your budget.**

Management and Staffing Capabilities

The work to be performed by your design team is very clear; to evaluate, prioritize and design within budget and schedule to meet the needs of the DHHR. In the past 35 years we have extensive experience with similar projects. Our project team has been chosen for this project and they are available to dedicate the necessary time to this effort. We are available to start immediately upon our being selected. This team is an "In-House" team that works together everyday and has done most of the projects here as a group. These team members have been working up to **nineteen years** together at McKinley & Associates. The technical depth of our professional staff indicates that this project can be accomplished without overloading our group or computer graphics systems.

The most important element of the entire process becomes **communication** from you to our designers. We use and welcome your input throughout the project. We continually achieve success in projects by maintaining **time and cost management, quality control and excellent communication** amongst the client and contractors.

The areas of expertise for each member coincides with his/her Role in this Contract. With our large staff we have the ability to have **registered engineers and architects designing within their area of expertise**. HVAC design by a Mechanical Engineer, electrical design by an Electrical Engineer, etc. These professionals are not only "In-House," we also have **depth in numbers** of each discipline in our firm.

We hold **weekly meetings** to discuss your project, the budget, schedule and quality assurance. We provide **Documented Minutes** of all of our meetings and encourage the Owner to participate in these meetings.

Our **Quality Assurance Program** starts with a peer review where a registered professional not involved in the design becomes reviewer of the project before going to bid. Additionally, at our regularly scheduled project meetings the entire design team is constantly reviewing the process.

We are confident we can meet your program requirements. We have worked with owners in many different sectors of business and have been able to **comply with their various requirements and standards**, including **Federal Agencies** such as the USPS, VA, DOD, FAA, HUD, EPA and NPS, and also **State Agencies** such as the State of West Virginia, WVARNG, West Virginia University, Marshall University, WV School Building Authority, West Virginia State Police, DOE, and the Department of Culture & History among others. We are able to respond to their needs, and we are certain that we are able to respond to all of your needs as well.

You appropriately recognize how **codes, and state / federal regulations** are important to a successful project. Our professional's design within these codes daily, as our practice is and remains a West Virginia practice and we are dedicated more than ever to the state in which we live. All documents will be prepared with the current WV State Building Code and WV State Fire Code as well as all **State and Federal Codes, Regulations, and Ordinances**. We are members of many organizations, and follow their standards, such as NFPA, CEFPI, AWI, WVEDC, AIA, NCARB, ASCE, ASPE, BOCA, ASHRAE, and ACI International.

Our **Eleven Month Walk-Through** is a process where our professionals return to your facility eleven months after the project is completed. At that time they review all the work that was completed and check all warranties. We are making sure all of the covered work is in order and that the warranties do not expire with equipment or product not working properly. We have been doing this for **19 years** which has now been adopted as an AIA 101 Standard. We also conduct Post Occupancy Evaluations with the Owner to find out how well we matched the Owners' needs.

11
eleven month walk-through



Qualifications

Founded in 1981, **McKinley & Associates** provides design services for projects representing more than \$100,000,000 annually in construction value. Our professional staff includes Engineers, Architects, designers, Commissioning Provider, Interior Designer, LEED Accredited Professionals (Sustainable and Energy Efficient "Green" Design), and more. We have a **broad range of skills and experience** for



projects involving medical, educational, government, recreational operations, commercial, manufacturers, hospitality, emergency facilities, and more. We have provided professional services in all 55 counties of West Virginia. **We are on the forefront of innovative design.** We have designed **LEED Certified and LEED Registered** projects. Not only have we won multiple **State** and local awards and recognitions for our designs, we have also won many **National** awards and recognitions; most recently, the J.B. Chambers Performing Arts Center was selected as an Outstanding Design by the American School & University Magazine's Architectural Portfolio.

The firm has completed many projects for **health care facilities**, including renovations and expansions of existing structures as well as new buildings. We have completed over a dozen projects for six Veterans Affairs Medical Centers in both West Virginia and Pennsylvania as well as numerous local and regional health care providers. From planning and implementing a feasibility study for a retirement community, to **specialty HVAC systems**, to design of an assisted living center, to additions to house MRI equipment, to outpatient surgical centers, to freestanding outpatient facilities and much more, our team has the ability to handle your project.

Our engineering and architectural staff has recently had special opportunities and experience related to various typical and atypical building types. For example, we designed the first Chilled Beam HVAC System in West Virginia, one of the first Variable Refrigerant Volume / Air-Cooled DX Multi-Zone Systems in the State, and one of the first buildings in West Virginia with all interior and exterior LED lighting. **We know the new technology, and when to apply it effectively.**

For all of our Clients we require a set of Operation & Maintenance Manuals be submitted as Close-out Documents. Often a videotaped demonstration of the instruction session(s) for each piece of equipment is required for future reference by the Owner's staff. Equipment specific Maintenance Agreements can be incorporated into the construction documents if the Owner believes staff availability might be sporadic. Also, testing, adjusting and balancing are provided by a third party entity to insure proper operation of MEP equipment. The Eleven-Month Walk-thru is specified to follow-up on the status of the completed work and to make it possible to review equipment maintenance and operation before the warranties expire. Lastly, modern HVAC systems have electronic monitoring options so that alerts are issued immediately upon detection. In addition, third party monitoring agreements of HVAC systems and Security Systems can be specified.

Medical / Health Care

WHEELING HOSPITAL

- Wheeling, West Virginia
- *Design of new Ultra-Sound Suites.
 - *Feasibility study for Retirement Community
 - *Training Center for Continuing Education
 - *Renovation of semi-private rooms into private rooms
 - *Center for Nursing Continuing Education
 - *Renovation of Professional Suites

OHIO VALLEY MEDICAL CENTER

- Wheeling, West Virginia
- *Renovation of Nurse Residence into Professional Suites
 - *MRI addition
 - *Fire suppression system
 - *Outpatient Surgical Center

REYNOLDS MEMORIAL HOSPITAL

- Moundsville, West Virginia
- *Physicians' offices/exam rooms
 - *Rapid Care Center renovations
 - *Emergency Room renovations

KEEP SMILING FAMILY DENTISTRY

- Wheeling, West Virginia
- *Dental Office Fit-Out
 - *Custom Casework & All New Equipment
 - *4 Exam/Operator Rooms
 - *A Three-Bay Hygienist Room

HOUSTON LEWIS GENERAL DENTISTRY

- Wheeling, West Virginia
- *New X-Ray Room

DR. GANZER MEDICAL OFFICE BUILDING

- Wheeling, West Virginia
- *Major Renovation Project
 - *Medical Spa and Cosmetic Center
 - *Medical Offices for Dermatology Practice

OHIO VALLEY PROFESSIONAL BUILDING

- Wheeling, West Virginia
- *Physicians offices
 - *Outpatient Surgical Center / Exam Rooms

WETZEL COUNTY HOSPITAL

- New Martinsville, WV
- *Community addition
 - *New emergency department

ST. CLAIRSVILLE HOSPITAL

- St. Clairsville, OH
- *General renovations

PETERSON HOSPITAL

- Wheeling, West Virginia
- *Fire Suppression system
 - *General renovations

DOCTORS URGENT CARE

- Wheeling, West Virginia
- *Freestanding Outpatient Facility

WOODS HEALTH CENTER

- Moundsville, West Virginia
- *Freestanding Clinic & Outpatient Facility

VAMC / BECKLEY, WEST VIRGINIA

- *Renovation of central computer room
- *Motion-sensing lighting controls
- *Same Day Surgery Center
- *Oncology Center
- *Addition for specialty clinics
- *Renovation of recovery area for outpatient surgery

VAMC / CLARKSBURG, WEST VIRGINIA

- *Clinical addition
- *Emergency room
- *Surgery and recovery suites
- *15-bed ICU
- *Expanded clinical laboratory
- *Modernized imaging service that includes CT scan and diagnostic nuclear medicine capabilities
- *Inpatient and outpatient pharmacies.
- *Primary care outpatient clinics
- *Specialty clinics for oncology, mental hygiene, PTSD, urology, surgery, dermatology, optometry, and otolaryngology
- *Doors and latches program

VAMC / MARTINSBURG, WEST VIRGINIA

- *Operating room suites electrical systems renovations
- *Nurses call stations

VAMC / HUNTINGTON, WEST VIRGINIA

- *Replacement of all clinical areas
- *Renovation of original hospital into hospital rooms
- *Medical air and Vacuum systems

VAMC / BUTLER, PENNSYLVANIA

- *Various Renovations to Buildings #1, #2, and #3

VAMC / PITTSBURGH, PENNSYLVANIA

- *Expansion of central computer facility
- *Renovation of pneumatic laundry system
- *Replacement of steam traps
- *Fire suppression system - five story building

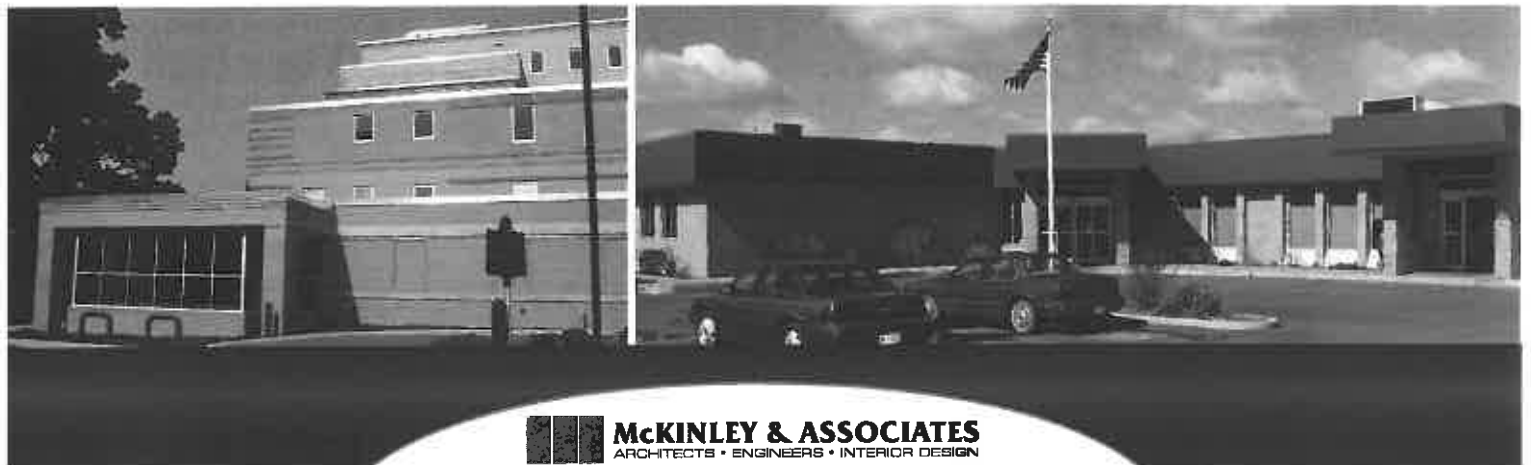

Recent Boiler Projects

This is just a small sampling of our recent boiler replacement projects, with a short write-up for your convenience. More in-depth project sheets are found in the following "Projects" tab.

United States Postal Service (USPS) Huntington – replacing hot water boiler with like-in-kind

USPS Monongahela – replacing hot water boiler with high efficiency condensing boiler

USPS Williamson – replacing hot water boiler with high efficiency condensing boiler

Oglebay Institute's Stifel Fine Arts Center – replacing steam boiler

Sisters of St. Joseph's - Mount St. Joseph Convent / Assisted Living – replacing hot water boiler with high efficiency condensing boiler

West Virginia University - Colson Hall – tying into Medium Pressure Campus steam and reducing to low pressure for heating

WVU Institute of Technology - Conley Hall – replacing a steam boiler with a hot water boiler

Southern West Virginia Community and Technical College - Wyoming Campus – replacing hot water boiler with high efficiency condensing boiler

Hancock County Schools - John D. Rockefeller IV Career Center – replacing hot water boiler with like-in-kind

Ohio County Schools - Bridge Street Middle School – As part of a HVAC renovation we converted a Cast Iron Sectional Boiler from Steam to Hot Water

Ohio County Schools - Madison Elementary School – replacing steam boiler for high efficiency hot water

Ohio County Schools - Ritchie Elementary School – replacing steam boiler

Ohio County Schools - Triadelphia Middle School – replacing steam boiler

Summers County Schools - Summers Middle School – replacing hot water boiler with high efficiency condensing boiler

Construction Administration & On-Site Representation

Construction Administrator Involved from the Beginning of the Design Phase

Observe the Construction Progress

Liaison between the Owner, Contractor, and Architects/Engineers

Responsible for All Construction Progress Meetings and Minutes

Monitor the Construction Schedule

Ensure that the Contractor is Following the Construction Documents

Verify Pay Application and Change Orders

**Typically On-Site Once Every Two Weeks
(Provide Additional On-Site Representation if Requested)**



Our **Construction Administrators** have an extra responsibility than what most firms' Construction Administrators have; our CAs are a part of the design process from **Day 1** (they are not thrown into the project only when construction starts; they are here from the beginning), so they know the ins-and-outs of the project. Our CAs have an important role as being the **liaison between the Owner, Contractor, and Architect**. The primary objective of the Construction Administration services is to ensure completion of work the way the client wants it - **as scheduled and as budgeted**. Our Project Coordinators evaluate the quality of the work to verify that it meets the level required by clients; in addition, they monitor the contractor's progress to ensure that they are following the Construction Documents. They observe the construction progress, are responsible for all construction meetings and minutes, and they verify pay application and change orders. The Construction Administrator is typically on-site once every two weeks, but we can provide additional on-site representation if requested.

Sustainable "Green" Design

Buildings designed today will need to meet the demands of the future; McKinley & Associates identifies the changes necessary in the design of today and to meet these demands. This approach helps to retain the buildings' long-term profitability and value, which achieves the buildings' **sustainability**.

McKinley approaches ecological design from a business perspective, offering **proactive** solutions to complex problems such as indoor air quality, energy efficiency, resource depletion, and water quality. With commercial and institutional project experience, the McKinley Team can work alongside local designers to provide sustainable design and construction guidance. We also offer full architectural design services and guided design workshops on sustainable design issues.

Our Philosophy is to provide our clients with experienced leadership as well as state-of-the-art and **innovative** design expertise to accomplish the goals of your projects. Function, economics and versatility, in addition to the development of **strong aesthetic appeal**, are crucial elements in our design process. We also believe that enhancement of the physical environment in which each individual lives and works should add significantly to the enjoyment of life. Our firm has dedicated our professional skills to attain these goals. **For a few recent sustainable awards**, we were honored to have won 5 Placemakers Awards from West Virginia GreenWorks at the Building Conference in Morgantown. In addition, **Cameron Middle/High School** won the 2014 Black Bear Award for the **Highest Achievement** for the West Virginia Sustainable Schools program, and was just selected on April 22nd as a 2014 U.S. Department of Education Green Ribbon School!

Moreover, Hilltop Elementary School is one of our many projects that we designed using **energy efficient** and **sustainable design** approaches. It was not until **after** construction had commenced that the Owner decided to submit for LEED Certification. This required a great deal of coordination with the architects, engineers, subcontractors and suppliers. Since we incorporated **good sustainable design practices** from the beginning, this allowed for an easy transition, and for the project to be successfully completed in July 2009. This is the **first** LEED Certified school in the state of West Virginia. Hilltop won a 2010 Gold Medal Green Building Award by Building of America. Hilltop also won the 2012 West Virginia Department of Environmental Protection's Clean Energy Environmental Award. Hilltop received the 2012 Black Bear Award for the **Highest Achievement** for the West Virginia Department of Education's Green Ribbon Schools program. In addition, in April 2012, Hilltop was one of 78 schools (which span 29 states and D.C.) to be awarded the **first-ever** U.S. Department of Education Green Ribbon Schools! Moreover, Hilltop won a 2013 Placemaker Award for Leadership of/for Place from the West Virginia GreenWorks.



McKinley and Associates has been honored to have won some very notable awards and to have received some very prestigious nominations over the years. We recently won a West Virginia Chapter of the American Institute of Architects Merit Award for our newly renovated Charleston Office; a project led by Thom Worlledge.



View of our award-winning Charleston Office renovation showing our centrally located conference room "Lantern." This glows all day long through the translucent walls, which are illuminated with natural daylight from a skylight above.



Leadership in Energy and Environmental Design





LEED® (Leadership in Energy and Environmental Design) Green Building Rating System™ developed by the U.S. Green Building Council (USGBC) is the nationally accepted standard for the design, construction, and operation of high performance green buildings (www.usgbc.org). In January 2001, our firm was the **first organization in West Virginia to join the USGBC**. No other WV firm joined until nearly 2 years later! We have **LEED Accredited Professionals** on staff, along with our skilled architectural/engineering team, who will efficiently and cost effectively achieve certification under this standard or we can guide you through the process in order to develop sustainability goals specific to your project.

We have **LEED® Accredited Professionals specializing in Building Design & Construction** on staff:

- Christina Schessler, AIA, LEED AP BD+C
- Thomas R. Worlledge, AIA, LEED AP BD+C, REFP

Our **LEED Certified Projects** are (LEED Rating System in parentheses):

-  **Hilltop Elementary School** in Sherrard, WV (LEED for Schools 2.0)
- **The First LEED Certified School in the State of West Virginia!**
-  **Building 55: West Virginia State Office Complex** in Logan, WV (LEED NC 2.2)

All of our current **LEED Registered Projects** are either under construction or in design with potential **LEED Platinum Certification** or potential **LEED Silver Certification**. Our LEED Registered Projects are (LEED Rating System in parentheses):

- Bellann in Oakhill, WV (LEED EB O&M)
- Cameron Middle/High School in Cameron, WV (LEED for Schools 2.0)
- SMART Office in Williamson, WV (LEED CI)

The LEED AP Specialty Logos signify advanced knowledge in green building practices and specialization in a particular field.



The LEED AP BD+C designation that both Thom and Christina have achieved represents specialization in commercial design and construction.



Thomas R. Worlledge, AIA, LEED AP BD+C, REFP has been a member of the USGBC since 2001; he was the **first LEED Accredited Professional in the state of West Virginia!** As a professional trainer for the Sustainable Building Industries Council, he teaches other design professionals in the art of High Performance School



Christina Schessler, AIA, LEED AP BD+C has been a member of the USGBC since 2009. In 2012 she received her Masters in Historic Preservation, so not only can she incorporate LEED "Green" aspects into new buildings; she can even incorporate energy efficient design into renovation/preservation

design. He is also a Founder & Chairman of the Board for the US Green Building Council's West Virginia Chapter.

projects. Twenty percent of a building's energy consumption is embodied in the existing physical structure itself!

The "USGBC Member Logo" is a trademark owned by the U.S. Green Building Council and is used by permission.



McKINLEY & ASSOCIATES
ARCHITECTS • ENGINEERS • INTERIOR DESIGN

Quality Control

Quality control at McKinley & Associates, Inc. is a constant process which **begins with the initial project activity and continues through document submissions, bidding, construction and owner occupancy.** The longevity and size of the firm and our history of success completing complex and innovative projects is founded upon our commitment to this process.

During the design phases, all personnel become fully versed in the client's program, project requirements and design standards. The design team is responsible for identifying for the West Virginia Department of Health and Human Resources any potential conflicts between program criteria and design standards and resolving those conflicts to your satisfaction.

As the schematic/concept plans are developed, Tim E. Mizer, PE, RA, QCxP, your Project Manager, will present plans for review and comments to a plan group depending on the nature of the work; e.g. engineers commenting on the engineering and architects critiquing the architecture (*a peer review with Architects, along with a Construction Administrator, is seen below*). Once a consensus is reached, the plans advance in the process.

Prior to the completion of each phase, a set of project documents is issued to each discipline for coordination, cross-checking and review. The following items are checked at that time:

- Drawings and specifications for program compliance.
- Drawings and specifications for internal coordination.
- Cost effectiveness of the design.
- Drawing accuracy.
- Compliance with appropriate codes and client standards.

After coordination check corrections are completed, Tim will review the documents and compare the completed documents with check prints to verify that corrections have been made in accordance with the project design criteria. A review set will be sent to the West Virginia Department of Health and Human Resources, the Fire Marshal and other governing authorities for preliminary review.

During the subsequent phases of design, all items are checked by persons other than those performing the daily design work in order to provide fresh insight. Prior to the final release of the documents, revisions are once again checked by the Project Manager and appropriately referenced on the drawings. Copies of the final documents will be distributed to the West Virginia Department of Health and Human Resources for final review and approval. A set is sent to the Fire Marshal and other governing authorities for final review comments. Comments are incorporated into the documents prior to issuance for advertising, bidding and construction.

Bid documents are issued after a final check to verify that all bid packages have current revisions included and are appropriately identified. Bid sets are numbered and registered to bidders so that each bidder may be kept informed of clarifications and addenda. We will provide assistance in analyzing and evaluating bids for construction, and assist with awarding the construction contracts.

During the construction, the processing of shop drawings and submittals will be controlled and monitored by Mr. Mizer, and includes the receipt, logging, review and return of submittals. Urgent items can often be expedited to satisfy the construction schedule. In addition, Mike Price, your Construction Administrator, will monitor the contractor's progress to ensure that they are following the Construction Documents, and verify that closeout documents are submitted in a timely manner upon Substantial Completion.



References

*(Federal - Open-Ended IDIQ Contracts,
including multiple boiler projects)*

Mr. Don Mackey
United States Postal Service
27497 Albert Pick Road
Greensboro, NC 27498
304 / 665-2894

*(Building 55: West Virginia State Office
Complex - LEED Certified)*

Mr. Robert P. Krause, PE, AIA
State of West Virginia
General Services Division
1900 Kanawha Boulevard East
Charleston, WV 25305
304/558-9018

*(Generators and HVAC renovations on
Multiple WVSP Facilities State-Wide)*

Colonel C. R. "Jay" Smithers
West Virginia State Police
725 Jefferson Road
South Charleston, WV 25309
304/746-2115

*(WVDHHR's new Ohio County office
renovation / fit-out)*

Mr. David J. Hildreth
WV Department of Administration
1409 Greenbrier Street
Charleston, WV 25311
304/558-1295

*(Keep Smiling Family Dentistry office
renovation / fit-out)*

Dr. Don Chapman
2100 Market Street
Wheeling, WV 26003
304/232-6956

*(Dr. Ganzer Medical Office Building
renovation / fit-out)*

Dr. Greg Ganzer
2101 Chapline Street
Wheeling, WV 26003
304/233-3240

*(Multiple projects, including HVAC
renovations and a School-Based Health Center)*

Dr. Kathy Kidder-Wilkerson
Superintendent
Hancock County Schools
104 North Court Street
New Cumberland, WV 26047
304/564-3411

(2 W&J generator projects)

Mr. Ed Chavern, LEED AP
Washington & Jefferson College
60 S. Lincoln Street
Washington, PA 15301
724 / 223-6534



Client Testimonials



West Virginia State Police
725 Jefferson Road
Smith Apartments, West Virginia 25309-1099
Executive Office

Earl Ray Combs
Colonel

Colonel C. R. "Jay" Smithers
Superintendent

September 8, 2011

Subject: Reference for McKinley & Associates

To Whom It May Concern:

The West Virginia State Police have had a professional relationship with McKinley & Associates since 1996. Not only do their Architects and Engineers listen to the needs of our law enforcers; they have gone beyond the call of duty to ensure our projects are top quality, run smoothly, and are completed on time.

Sincerely,

Col. C.R. "Jay" Smithers,
Superintendent

Equal Opportunity Employer



The Culture Center
1900 Kanawha Blvd., E.
Charleston, WV 25309-0360

Randall Reid-Smith, Commissioner
Phone 304.558.0220 • www.wv.culture.org
Fax 304.538.2779 • TDD 304.538.3662
10/4/2010

February 5, 2016

To Whom It May Concern:

The West Virginia Division of Culture and History and I would like to express our great appreciation for McKinley & Associates and the care and interest they always place in Historic Preservation projects across our State. Together, we have most recently completed restoration and renovation projects at West Virginia Independence Hall and the Grave Creek Museum and Archeological Complex. West Virginia Independence Hall is a National Historic Landmark. Both of these projects were completed successfully on Schedule and on Budget.

McKinley & Associates experience contributes greatly in recognizing the important challenges of preservation, conservation and rehabilitation of cultural and community buildings. Our professional relationship has continued to grow through many endeavors for over 15 years. Project examples include: Construction Projects, Studies, Historic Structure Reports, and Grants.

I highly recommend the services of McKinley & Associates to anyone in need of a professional and friendly Architectural and Engineering firm. We would like to take this opportunity to thank the staff of McKinley & Associates for their continued efforts and friendship.

Sincerely,

Mr. Randall Reid-Smith
Commissioner
304.558.0220

Design Team Flow Chart

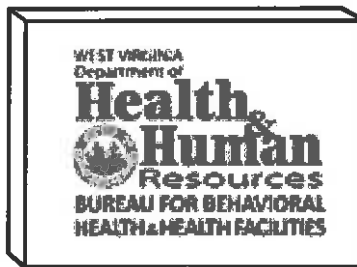

Project Manager / Point of Contact

Tim E. Mizer, PE, RA, QCxP

Engineering Team

Tim E. Mizer, PE, RA, QCxP

*Director of Operations /
Architectural Engineer / Architect / Commissioning Provider*

Darren S. Duskey, PE

Electrical Engineer

John L. Suhrie, PE

Structural Engineer

Michael A. Heath

HVAC/Mechanical & Fire Protection Engineering Designer

Michael J. Clark

Electrical Engineering Designer

Scott D. Kain

Electrical & Plumbing Engineering Designer

Architecture

Thomas R. Worlledge, AIA, LEED AP BD+C, REFP

*Architect / LEED Accredited Professional specializing in
Building Design & Construction*

Christina Schessler, AIA, LEED AP BD+C

*Architect / Historic Preservationist / LEED Accredited Professional
specializing in Building Design & Construction*

Construction Administration

Michael L. Price

** McKinley & Associates is willing to dedicate more professionals if they are needed; including more Architects and Designers, Interior Designer, CAs, and more.*



McKINLEY & ASSOCIATES
ARCHITECTS • ENGINEERS • INTERIOR DESIGN

Tim E. Mizer, PE, RA, QCCP

Architectural Engineer / Architect / Commissioning Provider

Director of Operations

EDUCATION:

Kansas State University
B.S. Architectural Engineering - 1983

University of Cincinnati
Architecture

PROFESSIONAL AFFILIATIONS AND REGISTRATIONS:

Registered Engineering In:
West Virginia
Ohio

Registered Architect in:
Ohio

**Qualified Commissioning Process
Provider**

PROFESSIONAL EMPLOYMENT:

McKinley & Associates
Director of Operations
Architect / Engineer / Commissioning
Wheeling, WV (1995 to present)

M.C.C. Engineering
Director of Design
Columbus, Ohio (1988-1995)

Schooley Caldwell and Associates
Electrical & Mechanical Design
Columbus, Ohio (1986-1988)

Mizer Design
Free Lance Architectural Engineering Design
Columbus, Ohio (1985-1986)

Envirotek, Inc.
Drafting and Electrical & Mechanical Design
Raleigh, NC (1984-1985)

SUMMARY OF EXPERIENCE:

A very talented and unique professional who is registered **both** in **engineering** and **architecture** which has provided him with a total understanding of the engineering components and the process necessary for integrating architectural design and building systems. Furthermore, as a **Qualified Commissioning Process Provider**, he has been formally trained to fully understand how integrated HVAC systems function and how systems interface with others to run your building efficiently. He joined McKinley & Associates in 1995, and has over 30 years of experience. As the Director of Operations, Mr. Mizer's presence is a key to the design procedures required to coordinate the functionality of the engineering systems into the aesthetics of a building space. He has worked on many relevant projects, such as building assessments, boiler/HVAC renovations, medical facilities, energy efficient projects, and more.

NOTABLE PROFESSIONAL EXPERIENCES:

West Virginia Department of Health & Human Resources' Ohio County Office Building fit-out / renovations

Building 55: WV State Office Complex in Logan (LEED Certified)

Building 34: WV State Office Complex in Weirton

USPS - worked on a multitude of Post Offices in WV & PA, including dozens of HVAC projects

Dr. Ganzer Medical Office Building fit-out / renovations

Dr. Don Chapman's Keep Smiling Family Dentistry fit-out / renovations

VAMC Beckley renovations

Wetzel County Hospital addition/renovations

Marietta Memorial Hospital

OVMC Nurses Residence Hall

Chambers YMCA renovations

WV Army National Guard - Multi-Purpose Building

WV Army National Guard - Mountaineer Challenge Academy

Orrick's Global Operations Center office building fit-out

West Virginia State Police - dozens of renovations, additions, and new detachments, including multiple HVAC modernization projects

Raleigh County Emergency Services Authority HVAC renovations

Hilltop Elementary School (LEED Certified)

Wheeling Island Hotel•Casino•Racetrack multiple projects

Sisters of St. Joseph - Mount St. Joseph Convent Living renovations

Holiday Inn Express & Suites - multiple locations

WVU Institute of Technology - Maclin Hall Dormitory renovations



Darren S. Duskey, PE

Electrical Engineer

EDUCATION:

The Ohio State University
B.S. Electrical Engineer - 1993

Marshall University
Graduate courses in Engineering

PROFESSIONAL AFFILIATIONS AND REGISTRATIONS:

Registered Professional Engineer in:
Ohio
Pennsylvania
West Virginia

PROFESSIONAL EMPLOYMENT:

McKinley & Associates
Wheeling, WV (2002 to present)

Pickering Associates
Parkersburg, WV (1997-2002)

Magnetic Specialty, Inc.
Marietta, OH (1995-1997)

Inland Products, Inc.
Columbus, OH (1993-1995)

SUMMARY OF EXPERIENCE:

Mr. Duskey has over 20 years of experience with projects ranging from electrical design of health care facilities, a wide array of generators and emergency power systems projects, governmental, higher educational, PK-12 schools, State Police detachments, large and small industrial projects, energy efficient buildings, and much more. He has extensive knowledge with the National Electrical Code, state building codes, building industry standards and practices, and has demonstrated the ability to design qualitative and economic solutions to a myriad of challenges.

NOTABLE PROFESSIONAL EXPERIENCES:

WVDHHR's new Ohio County office building fit-out

Building 55: West Virginia State Office Complex in Logan (LEED Certified), including generator

Building 34: West Virginia State Office Complex in Weirton

WVDRS Wheeling District's new office space fit-out

Dr. Don Chapman D.D.S. / Keep Smiling Family Dentistry Office

Weirton Elementary School / School-Based Health Center

West Virginia State Police - multitude of projects across West Virginia, including multiple generators at various detachments, E911 Centers, the WVSP Headquarters, and the Back-Up Data Center

West Virginia University - multiple projects at their various campuses, including projects with generators at: Colson Hall in Morgantown WV, State Fire Training Academy in Jackson's Mill WV, and WV Tech's Maclin Hall Dormitory in Montgomery WV

Washington & Jefferson College - generators at Thompson Hall and the Commons building

Cabela's Eastern Distribution Center, including major generator

J.B. Chambers Performing Arts Center, including major generator

United States Postal Service - multiple projects across WV & PA

Charleston Enterprise Center office renovations (2009 WV AIA Design Award winner - energy efficient "green" design)

WV Army National Guard - Multi-Purpose Building

WV Army National Guard - Mountaineer Challenge Academy

Candlewood Suites Hotel, Morgantown, WV

Holiday Inn Express Hotels & Suites - multiple locations in many states

Wagner Building multiple renovations

Carenbauer Wholesale Corp. office renovations / warehouse addition

Ohio Valley Towers office building renovations

Wheeling Island Hotel•Casino•Racetrack multiple projects

Hilltop Elementary School (LEED Certified)

Chambers YMCA renovations



John L. Suhrie, PE

Structural Engineer

EDUCATION:

Pennsylvania State University
B.S. Civil Engineering

PROFESSIONAL AFFILIATIONS AND REGISTRATIONS:

Registered Professional Engineer in:

Delaware
Kansas
Michigan
Ohio
Pennsylvania
West Virginia

Professional Land Surveyor in:

Pennsylvania

Member:

American Society of Civil Engineers
American Concrete Institute
American Institute of Steel Construction
National Academy of Building Inspection
Engineers
National Society of Professional Engineers

PROFESSIONAL EMPLOYMENT:

Suhrie Engineering LLC
President, Structural Engineer
Pittsburgh, PA (2002 to present)

SUMMARY OF EXPERIENCE:

Mr. Suhrie has over 40 years of experience as a Professional Engineer with extensive and progressive experience in structural engineering, forensic inspections, project management, and engineering administrative with major engineering and construction firms. Responsibilities and experience includes forensic investigation of structural damage and building collapse, construction planning and scheduling, commissioning, construction problem trouble shooting investigation and development of resolutions, engineering and construction estimating, root cause investigations of engineering and construction problems using "Tap Root" and other investigation techniques, investigation of steel fabrication and field fit-up problems, structural engineering and design, structural inspections, as well as construction layout, surveying and field inspection. **McKinley & Associates has a 13+ year ongoing relationship with Suhrie Engineering on dozens of projects throughout West Virginia and Pennsylvania, ranging from new construction to additions and renovations.**

NOTABLE PROFESSIONAL EXPERIENCES TEAMING WITH MCKINLEY & ASSOCIATES:

United States Postal Service - Kane, PA
United States Postal Service - Monongahela, PA
United States Postal Service - New Cumberland, WV

West Virginia State Police - Berkeley County
West Virginia State Police - Hancock County
West Virginia State Police - Jackson County

Dr. Ganzer Medical Office Building

Lincoln National Bank

Wheeling Island Hotel•Casino•Racetrack - multiple projects

Wheeling Island Fire Station

Sisters of St. Joseph Convent

Braxton County Senior Citizen Center

Bennett Square business center

Wagner Building business center

Cameron American Legion

Carenbauer Wholesale Corporation office & warehouse

West Virginia University - Colson Hall

The Linsly School - Baner Hall

The Linsly School - Behrens Gym

Brooke Co. Schools - Follansbee Middle

Grant Co. Schools - Maysville Elementary

Marshall Co. Schools - new Cameron Middle/High (LEED Registered)

Marshall Co. Schools - John Marshall High

Ohio Co. Schools - Middle Creek Elementary

Tyler Co. Schools - Tyler Consolidated

Wetzel Co. Schools - Long Drain Elementary

Michael A. Heath

HVAC / Mechanical & Fire Protection Engineering Designer

EDUCATION:

ITT Technical Institute
Associate Degree in Specialized Technology:
Computer-Aided Drafting Technology - 2000

PROFESSIONAL EMPLOYMENT:

McKinley & Associates
Mechanical & Fire Protection Designer
Wheeling, WV (2007 to present)

Janus, Inc.
AutoCAD Designer / Project Manager
Pittsburgh, PA (2002-2007)

Comunale Automatic Sprinkler
Fire Protection Designer
Pittsburgh, PA (July 05 - Oct 05)

S.A. Comunale Inc.
Fire Protection Designer
Pittsburgh, PA (2000-2002)

SUMMARY OF EXPERIENCE:

Mr. Heath brings a cross-trained design background to your project, and has vast knowledge in a diverse range of disciplines. He was trained by the National Fire Protection Association (NFPA) in Dallas, Texas, and has used these skills to work on projects from multiple business sectors and with various sizes, such as the 4 story, 1,500,000 square foot David L. Lawrence Convention Center in Pittsburgh, Pennsylvania. He has vast expertise in designing and calculating fire protection systems, standpipes, dry and wet systems, hydraulics, and water cannons; stock listing materials for systems; as well as surveying job sites and frequent business trips to coordinate jobs.

NOTABLE PROFESSIONAL EXPERIENCES:

WVDHHR's new Ohio County office
Building 55: WV State Office Complex in Logan (LEED Certified)
Dr. Chapman's Dental Office
West Virginia Army National Guard - Multipurpose Building at Camp Dawson in Kingwood
WVDRS Wheeling District's new office space
Wheeling Island Hotel•Casino•Racetrack - various projects
Candlewood Suites Hotel
Holiday Inn Express Hotel & Suites - multiple locations
Panhandle Cleaning & Restoration warehouse & office building
Cabela's Eastern Distribution Center
Silver Company - Moss Neck Storage Building
Carenbauer Wholesale Corp. office renovations / new warehouse
West Virginia Independence Hall renovations
Capitol Theatre renovations
Fairmont State University - 3 new College Apartment Buildings
For 14 West Virginia counties; provided Fire Protection and Mechanical assessments at every school (160+ schools), for their 10-year Comprehensive Educational Facilities Plan (CEFP)
Boone County Schools - multiple HVAC & renovation projects
Marshall County Schools - multiple HVAC & renovation projects
Ohio County Schools - multiple HVAC & renovation projects
Hancock County Schools - multiple HVAC & renovation projects
Ritchie County Schools - Ritchie County Middle/High School HVAC
Tyler County Schools - 3 HVAC renovations
Wetzel County Schools - Long Drain Elementary



Michael J. Clark Sr.

Electrical Engineering Designer

EDUCATION:

Eastern Gateway Community College
A-ATS Electro-Mechanical Engineering - 2012

Jefferson Community College
A-ATS Electrical Trade Technology - 2003

PROFESSIONAL AFFILIATIONS AND REGISTRATIONS:

Certified in SMAW Weld Process & Basic
Welding and Applications 2002

West Virginia Journeyman License

Ohio Fire Alarm License

OSHA 30 Certified

PROFESSIONAL EMPLOYMENT:

McKinley & Associates
Electrical Engineering Designer
Wheeling, WV (2012 to present)

Arcelor Mittal
Maintenance Technician Electrician
Weirton, WV (2012)

M.J. Electric
Journeyman Electrician
Iron Mountain, MI (2010-2012)

Erb Electric Company
Journeyman Electrician
Bridgeport, OH (2009-2010)

Bechtel Group Inc.
Journeyman Electrician
Glendale, AZ (2009)

Cattrell Companies, Inc
Journeyman Electrician
Toronto, OH (1998-2009)

SUMMARY OF EXPERIENCE:

Mr. Clark is an Electrical Engineering Designer and a Certified Journeyman Electrician with over 20 years of industrial, commercial and residential experience. He is knowledgeable in all areas of the national electrical code and excels in analyzing and solving problems with various electrical controls and systems. Mr. Clark brings a cross-trained background to our projects, being skilled in both the design and the construction ends which gives him a unique ability to understand all aspects of a project. He is also adept in performing electrical and mechanical installations, maintenance and repairs in plant facilities. Furthermore, he is seasoned as an Electrical Foreman and Superintendent on both commercial and industrial job sites. His key skills include Electrical Systems & Controls, Installations & Maintenance, Generators & Transformers, Electromechanical Repairs, Blueprints & Schematics, Switches & Circuit Breakers, Electrical Code, Safety & QA, Wiring Diagrams, Troubleshooting, Testing Instruments, Motors & Conduit, CAD-2D/3D, Welding, & Residential construction.

NOTABLE PROFESSIONAL EXPERIENCES:

Building 55: WV State Office Complex in Logan (LEED Certified)
Dr. Chapman's Dental office
WVDRS Wheeling District's new office space
Candlewood Suites Hotel
Holiday Inn Express Hotel & Suites
Carenbauer Wholesale Corp. office renovation/warehouse addition
Follansbee City Building
Wellsburg City Building
Jefferson County Courthouse
Union Bank
City of Steubenville - Parks Lighting
Silver Company - Moss Neck Storage Building
Grave Creek Mound Museum
West Liberty University - Football Field Lighting
Brooke County Schools - Adult Learning Center (ALC)
Grant County Schools - Maysville Elementary
Hampshire County Schools - Animal Vet Science Center
Hancock County Schools - Weirton Elementary
Hancock County Schools - Oak Glen High
Hancock County Schools - Weir High
Marshall County Schools - Cameron High
The Linsly School



Scott D. Kain

Plumbing & Electrical Engineering Designer

EDUCATION:

Technology Education College /
Ohio State University
Associates in Mechanical Design - 1996

PROFESSIONAL EMPLOYMENT:

McKinley & Associates
Engineering Designer
Wheeling, WV (2001 to present)

HAWA Inc.
Mechanical Designer
Columbus, OH (1998-2001)

Autotool Inc.
Engineer
Columbus, OH (1995-1998)

SUMMARY OF EXPERIENCE:

Mr. Kain is an accomplished engineering designer who has performed in all the engineering trades we provide; specializing in electrical, plumbing, and fire protection. He has been utilized for various McKinley & Associates' projects that needed additional mechanical, structural, and architectural manpower. In addition, Mr. Kain has also provided 3D renderings, to aid in business development, during his long tenure at McKinley & Associates.

NOTABLE PROFESSIONAL EXPERIENCES:

WVDHHR's new Ohio County office fit-out / renovations
Building 55: WV State Office Complex in Logan (LEED Certified)
Building 34: WV State Office Complex in Weirton
VAMC Beckley
Wetzel County Hospital
OVMC Nurses Residence Hall
Dr. Ganzer Medical Office Building fit-out / renovations
HealthPlex fit-out / renovations
Holiday Inn Expresses & Suites- multiple projects
WVDRS Wheeling District's new office space fit-out / renovations
United States Postal Service - statewide post offices
West Virginia State Police - multiple projects state-wide
West Virginia Army National Guard - multiple projects
Wheeling Island Hotel•Casino•Racetrack multiple projects
Wheeling Island Fire Station
Chambers YMCA
Orrick's Global Operations Center
Maxwell Centre
Bennett Square
Wagner Building
Panhandle Cleaning & Restoration warehouse and office building
West Virginia University - Colson Hall
West Virginia University - State Fire Training Academy
WVU Institute of Technology - Maclin Hall
Cabela's Eastern Distribution Center
WV Northern Community College - B. & O. Building
Marshall County Schools - Hilltop Elementary School (LEED Certified)
Marshall County Schools - Cameron High School (LEED Registered)



Thomas R. Worledge, AIA, LEED AP BD+C, REFP

Architect / Specialized LEED Accredited Professional



EDUCATION:

Virginia Polytechnic Institute & State University
Master of Architecture - 1992

Fairmont State College, School of Technology
B.S. Architectural Eng. Tech. - 1983

PROFESSIONAL AFFILIATIONS AND REGISTRATIONS:

Registered Architect in:

West Virginia
Ohio
Pennsylvania
Tennessee
Virginia

National Board Certification:

NCARB #48600

President:

West Virginia Society of Architects

Member:

The American Institute of Architects
US Green Building Council
Sustainable Building Industries Council
Recognized Educational Facility Professional
(REFP)

Former voting member:

ASHRAE 90.1 International Energy Code
Committee

PROFESSIONAL EMPLOYMENT:

McKinley & Associates
Manager, Charleston Office
Charleston, WV (2005 to present)

Proactive Architecture Inc.
President
Charleston, WV (1999-2005)

Silling Associates Inc.
Vice President
Charleston, WV (1992-1999)

TAG Architects
Charleston, WV (1985-1990)

Alpha Associates Inc.
Morgantown, WV (1983-1985)

SUMMARY OF EXPERIENCE:

Mr. Worledge is a skilled Architect with over 30 years of experience, who has been the former President of the WV chapter of AIA, has received State and National design awards, and placed in National and Global design competitions. Unlike many architects who are new to green building and alternate energy, Thom started his career designing and building alternate energy systems, and was the first LEED Accredited Professional in West Virginia! He believe energy efficient design is simply good design practice. As a **LEED Accredited Professional specializing in Building Design & Construction (LEED AP BD+C)** and a **recognized sustainable design expert**, he has **2 LEED Certified projects, multiple LEED Registered projects**, several other energy-efficient projects, has articles published in State and National trade publications, was a featured speaker at multiple State and National conferences, served on the committee that set the ASHRAE 90.1 Standards for the International Energy Code, professionally teaches and trains other professionals in the art of High Performance Design, is a Founder & Chairman of the Board for the US Green Building Council's West Virginia Chapter, and much more.

NOTABLE PROFESSIONAL ACHIEVEMENTS:

West Virginia Department of Health & Human Resources' Ohio County Office Building fit-out / renovations

Building 55: WV State Office Complex in Logan (**LEED Certified**), includes generator

Veterans Affairs Medical Centers - multiple VAMCs around WV and PA

United States Postal Service - multiple projects throughout WV

West Virginia State Police - new Logan Detachment / Back-Up Data Center for the WVSP Headquarters (includes generator)

West Virginia State Police Academy - Renovations to Buildings A, B, and C; New Buildings D and Multi-Purpose Building

Nicholas County Division of Homeland Security & Emergency Management - E-911 and Emergency Operations Center studies

Fairmont State University - College Apartments Complex

WVU Institute of Technology - Maclin Hall Dormitory in Montgomery

West Virginia University - University Police Building

Charleston Enterprise Center renovation (WV AIA Design Award)

Williamson SMART Office (LEED Registered / Placemaker Award)

Natural Energy Design (NED) Building (Placemaker Award)

Bellann in Oakhill, WV (LEED Registered)

Big Sandy Arena & Convention Center

Marshall County Schools - Hilltop Elementary School (**LEED Certified**) - won multiple WV and National Awards & Recognitions)

Wood County Schools - Parkersburg High renovation (\$23 million) & Williamstown High renovation (\$13.5 million)



Christina Schessler, AIA, LEED AP BD+C, NCARB

Historic Preservationist / Architect / Specialized LEED AP



EDUCATION:

The Pennsylvania State University
Bachelor of Architecture - 1988

Savannah College of Art & Design (SCAD)
Masters Degree in Historic Preservation - 2012

PROFESSIONAL AFFILIATIONS AND REGISTRATIONS:

Registered Architect in:

Ohio
Pennsylvania
Virginia
West Virginia

NCARB Certificate - 2005

LEED® Accredited Professional

Member:

American Institute of Architects
City of Wheeling - Building Codes Board
of Appeals
Preservation Alliance of West Virginia
The Association for Preservation Technology
International

Former Member, Board of Director, & Treasurer:

The Midwife Center for Birth & Women's
Health / Pittsburgh, PA

PROFESSIONAL EMPLOYMENT:

McKinley & Associates
Wheeling, WV (2004 to present)

MacLachlan, Cornelius & Filoni Architects
Pittsburgh, PA (1999-2004)

Perfido Weiskopf Architects
Pittsburgh, PA (1996-1999)

T.L. Cox & Associates
Beaver, PA (1990-1996)

Valentour English Bodnar Architects
Mt. Lebanon, PA (1989-1990)

Kenny Williams & Williams Building Diagnostics
Maple Glen, PA (1988)

SUMMARY OF EXPERIENCE:

For over 25 years, Ms. Schessler has obtained a wide range of **governmental, historical preservation, medical, educational,** and other project experience. She recently completed her **Masters in Historic Preservation**, and has a **passion for restoration, renovation, and modernization projects. For Independence Hall and Bennett Square, she won Heritage Tourism Awards from the Preservation Alliance of West Virginia. She also won a Pittsburgh History and Landmarks Restoration Award for the City Theater restoration project.** Ms. Schessler is adept at developing space and utilization programs with Clients who are unfamiliar with the architectural design process. As a **LEED Accredited Professional specializing in Building Design & Construction (LEED AP BD+C)**, Christina will also be able to provide direction to your project to develop a design that includes energy efficiency.

NOTABLE PROFESSIONAL EXPERIENCES:

USPS Clarksburg Finance Station historic preservation, renovations
USPS Shenandoah Post Office historic condition report
USPS Altoona historic preservation, renovations, Section 106 report
USPS Monongahela historic preservation, renovations
West Virginia Independence Hall historic preservation, renovations
Ft. Henry Building historic preservation, renovations, grants, reports
Harrison County Courthouse historic preservation, roof repair
Bennett Square Office Building historic preservation, renovations
Sisters of St. Joseph Convent historic preservation, renovations
Wagner Building multiple office renovations, historic preservation
Lincoln National Bank historic preservation, renovations
Washington & Jefferson College - Old Main historic preservation
The Linsly School historic preservation, renovations
Madison Elementary historic preservation, renovations
Bishop's Chapel Mausoleum historic preservation, renovations
City of Steubenville historic rehabilitation program, multiple projects
Dr. Don Chapman D.D.S. / Keep Smiling Family Dentistry Offices
Valley Ambulance addition*
Bethany College Health and Wellness Center, renovation*
Beaver Valley Burn Building site development*
The Beaver County Medical Center, Women's Health Center*
The Beaver County Medical Center, Rheumatology Expansion*
St. Clair Hospital, Woman's Breast Cancer Health Clinic*
The Midwife Center for Birth & Women's Health, Birthing Suites*
United Cerebral Palsy Center, renovations and additions*

** previous work experience with a firm other than McKinley & Associates*



McKINLEY & ASSOCIATES
ARCHITECTS • ENGINEERS • INTERIOR DESIGN

Michael L. Price

Construction Administrator

EDUCATION:

Belmont Technical College
Certified Surveyor

Licensed E.I.F.S. Technician

PROFESSIONAL AFFILIATIONS AND REGISTRATIONS:

Board Member:
West Virginia Capitol Building Commission

Member:
Wheeling Central Catholic Boosters
Our Lady of Peace Church
O.L.P. Basketball Coach

Vice President:
Circus Saints & Sinners

Former President:
Mt. Olivet Baseball Association

PROFESSIONAL EMPLOYMENT:

McKinley & Associates
Construction Administrator
Wheeling, WV (2009 to present)

Wheeling Hospital
Project Administration Carpentry Dept.
Wheeling, WV (2006-2009)

Main Street Bank
Foreclosure Property Inspector
Wheeling, WV (2003-2009)

Michael Price Construction, LLC
Owner
Wheeling, WV (2004-2007)

J.D. Fletcher Construction
Foreman, Supervisor and Estimator
St. Clairsville, OH (1989-2004)

National Road Utility Company
Sales, Product Inventory and Delivery
(1987-1989)

Real Contracting and Drywall
Framer, Finisher
(1985-1987)

SUMMARY OF EXPERIENCE:

Mr. Price has over 30 years of experience in the construction industry, especially in the **medical/health care, historic preservation, governmental, educational,** commercial, and residential construction. **His previous job was a Project Administration for the Carpentry Department at Wheeling Hospital; from this he will bring vast insight to your project with his thorough understanding of building construction, codes, standards, and regulations.** In addition, he has close work with architects and engineers in print takeoff and design. He joined McKinley & Associates in 2009 as a Construction Administrator; observing the construction progress of multiple notable projects, such as the **awards-winning West Virginia Independence Hall historic preservation project** and the J.B. Chambers Performing Arts Center at Wheeling Park High School among others. **Mr. Price was recently appointed by Governor Earl Ray Tomblin to the Capitol Building Commission - West Virginia Division of Culture & History.**

NOTABLE PROFESSIONAL EXPERIENCES:

West Virginia Department of Health & Human Resources' Ohio County office fit-out / renovations

Reynolds Memorial Hospital Rapid Care Center

Keep Smiling Family Dentistry Office fit-out / renovations

The Ryan Ferns HealthPlex fit-out / renovations

Shenango Valley YMCA Wellness Center and Indoors Sports Complex

Howard Long Wellness Center renovation*

Stratford Pediatric Rehab Center*

Wheeling Hospital Children's Rehab Center*

Wheeling Hospital Cancer Center*

Wheeling Hospital Breast Center Expansion*

Wheeling Clinic - Visiting Nurses Association (VNA) Expansion*

Wheeling Renal Care Center*

United States Postal Service - multiple projects across West Virginia and western Pennsylvania, including historic preservation

West Virginia Independence Hall historic preservation / renovations

Ft. Henry Building historic preservation / renovations

Capitol Theatre historic preservation / renovations

United States Postal Service - multiple projects, including historic preservation / renovations

Grave Creek Mound Museum renovations

Bennett Square Office Building historic preservation / renovations

Madison Elementary renovations / historic preservation

J.B. Chambers Performing Arts Center, including major generator

** previous work experience with a firm other than McKinley & Associates*

West Virginia Department of Health and Human Resources Office Building

Wheeling, West Virginia

Owner

WV Department of Administration:
Real Estate Division

Size

56,783 SF

Construction Cost

\$2 million

Project Architects-Engineers

McKinley & Associates

Project Architect

Thomas R. Worledge,
AIA, LEED AP BD+C, REFP

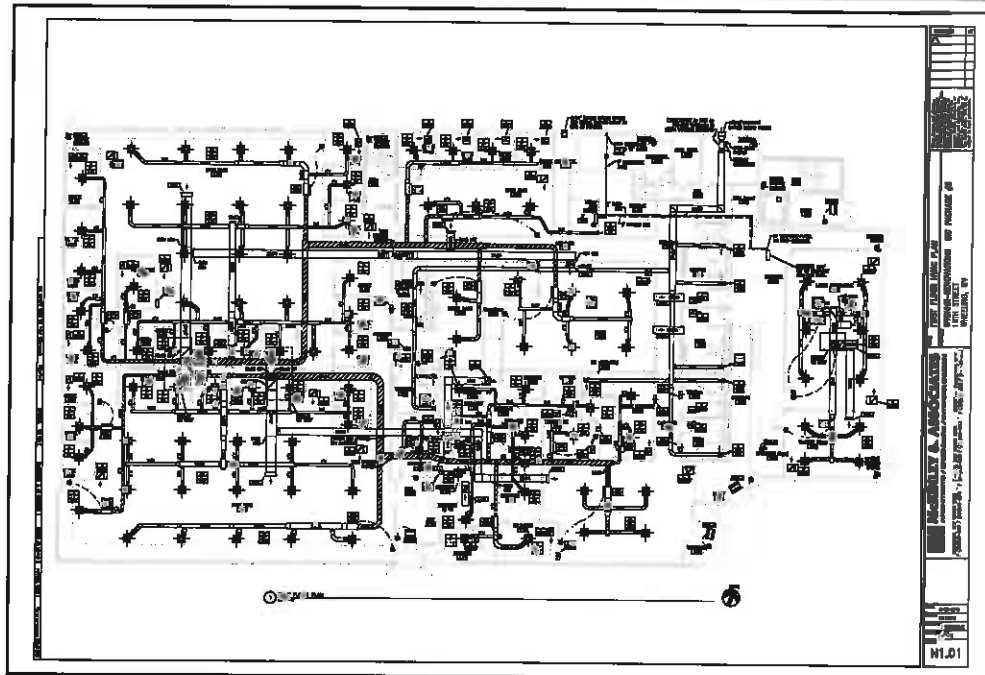

We were asked by our client to renovate/adaptively reuse a car showroom and service area into an office building (now called the Mary Margaret Laipple Professional Building). The first floor fit-out includes space for the West Virginia Department of Health and Human Resources' (DHHR) Ohio County office. The 56,783 SF building was concrete and designed for cars; not people. The first challenge of the renovation was to remove a large ramp that connected two floors of the building and level the concrete floors. We worked with our client to fit the DHHR's program into the space and maximize the use of the space. We had to work around the existing structural walls and columns and provide fire escapes at the different floor levels of the floor structure. The initial \$2 million fit-out project was built in three phases: the exterior was completed first (including new security doors, windows, skin, etc.), next the interior design and renovations including major HVAC / mechanical and electrical systems to provide a state of the art facility for the DHHR's use, and then the parking lot and emergency exit fire stair tower so the project could be fast tracked to meet the Owner's 2013 move-in requirements. We worked with the local and state code officials to bring the building into compliance with the current building and fire codes and provide access to all of the occupied areas of the building. The fit-out was divided into three distinct spaces: secure office space, Client space, and training areas. There are dozens of individual offices, open office work areas, a large video conference room, smaller conference rooms, training rooms, interview rooms, and much more. The Office space is secured from the client area by an access control system. The training space was designed to be stand alone for use by other State staff training. We provided a separate entrance for future tenants of the upper two floors and to keep the future renovation cost to a minimum. There are multiple entryways and doors, both interior and exterior, with different levels of security access. The showroom windows were mostly in-filled because of the sensitive nature of the materials in the DHHR's office, but windows high on the wall provide natural daylighting.



BEFORE
and AFTER



Building 34 West Virginia State Office Complex

Weirton, West Virginia

Owner
State of West Virginia

Size
39,500 SF

Construction Cost
\$4 million

Project Architects-Engineers
McKinley & Associates

Project Architect
Gregg P. Dorfner, AIA, REFP

Contractor
Walters Construction

To better serve the citizens of the Northern Panhandle of the State, the State of West Virginia established an office building in the City of Weirton. This **Weirton State Office Complex (also known as Building 34)** is a \$4 million state-of-the-art building that houses offices for multiple



state agencies. This State Office Building was completed in 2006, and accommodates the Department of Health and Human Resources, Rehabilitation Services, the Bureau of Employment Programs, the Division of Motor Vehicles, the Lottery Commission, and the Work Force Investment Board. This two-story, 39,500 SF office building was constructed with a rooftop HVAC System, structural steel frame and concrete foundations, cast concrete floors, precast concrete panel system, EPDM roof, two elevators, and building automation system. For parking, there was a large main lot and separate smaller lots to accommodate every client and/or building in the complex; this includes 14 handicapped parking spaces. Also included was site work. For security, the entire building has swipe-card access - both inside and outside, employee-only entrances, an x-ray machine, metal detector, bullet-proof glazing and tinted/reflective glazing, uninterruptible power supply, CCTV video monitoring and other surveillance equipment. There are various finishes and furnishing, such as desks, work stations, different floor materials (carpet, carpet tile, vinyl composite tile, unglazed ceramic tile, solid vinyl tile, and sealed concrete), casework, various door styles and swipe-access, bulletproof transaction windows, kitchen, laminated countertops, adjustable shelving, painted or glazed ceramic tile walls, and much more.

The first and second floor building commons spaces includes entry, security, lobby, restrooms, elevators, stairs, break room, conference room, and more. The DHHR spaces on the second floor includes 14 offices, an "open" office east and an "open" office west, work rooms, multiple swipe-card access doors, employee-only entrance, waiting room, reception, classroom/conference, regular conference room, resource room, interview room, family visitation room, server rooms, storage rooms, and more. The Rehab spaces on the first floor includes 7 offices, clerical, conference room, waiting room, an employee-only entrance, and more. The Bureau of Employment Programs spaces on the first floor includes 2 "open" work station rooms, manager offices, counselor office, work force training room, a large waiting room, hearing room/conference, server room, and storage. The DMV spaces on the first floor includes work stations, office break room, a large waiting area, licens center, driver's testing room, photo area, data, plate/storage room, employee-only entrances, and more. The Lottery space on the first floor includes an office, an "open" office room, conference, security room, supply room, a separate entrance lobby, and data room.

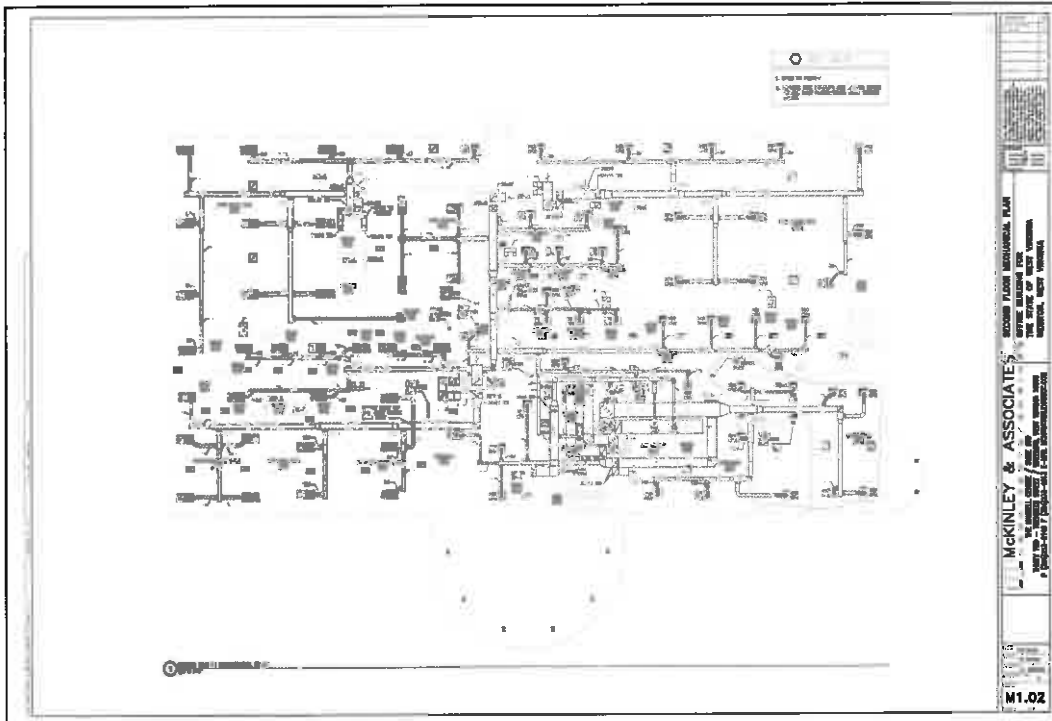

Building 55 West Virginia State Office Complex



Logan, West Virginia

Owner
State of West Virginia

Size
53,200 SF approx.

Project Architects-Engineers
McKinley & Associates

Project Architect
Thomas Worlledge,
AIA, LEED AP BD+C, REFP

Contractor
Massaro Corporation

Commissioning Agent
Iams Consulting, LLC

City leaders were searching for a catalyst to stimulate community efforts to revitalize downtown Logan, West Virginia. This recently completed office building - dedicated on August 16, 2013 - has become that inspiration. The building is designed to reflect the history and culture of the area while incorporating current technology and safety elements, thus empowering the community leaders to create a vibrant connected urban core. This new 5-story building underscores its major role in the development and revitalization of downtown Logan by **uniting office space for 127 employees for 6 State agencies** under one roof, whom were once scattered throughout the city. The agencies include the **Department of Health and Human Resources**, Division of Rehabilitation Services, the Offices of the Insurance Commissioner, State Tax Department, WorkForce West Virginia, and Workforce Investment Board. The 53,200 SF building provides current technology, flexibility for future growth, and security features for existing and future tenants.



At the request of the Owner, the building was designed to be **energy efficient** and meet **sustainable design** goals, confirmed by LEED and energy star requirements. In March 2014, this project became **LEED Certified**. To help achieve this, the HVAC System included the installation of 2 high efficiency condensing boilers, pumps with variable speed drive control, custom air handling units with chilled and hot water coils, variable air volume boxes with hot water heating coils, water cooled chiller with cooling tower, packaged rooftop energy recovery ventilator, and direct digital controls.

There is a back-up/emergency generator for life safety systems and data server rooms. It is a 300kW, 480/277V, 3 Phase, 4W diesel generator with outdoor enclosure, concrete pad, and in-base fuel tank. The generator, Automatic Transfer Switches (ATS), controls, and annunciator meet the requirements of NFPA 110, "Standard for Emergency and Standby Power Systems". This generator powers emergency lighting and provides backup power to critical building systems.

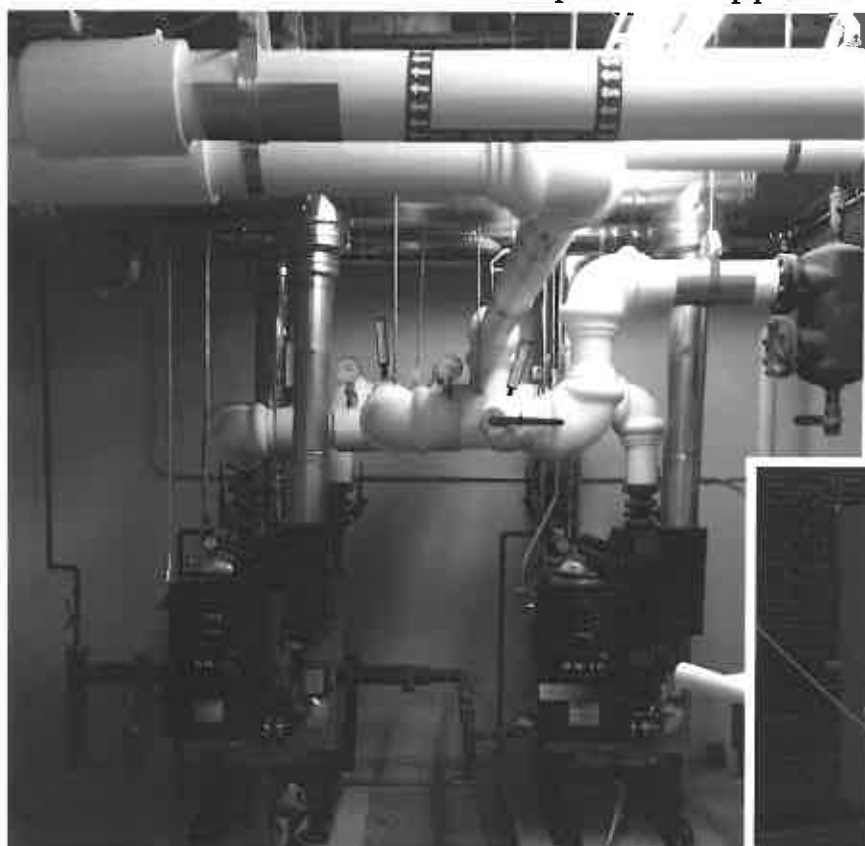

2 Open-Ended IDIQ Contracts

United States Postal Service

Appalachian Area (West Virginia & Virginia) and Erie/Pittsburgh District in Pennsylvania

Owner

United States Postal Service

Construction Cost

Multiple projects completed under 2 multi-year open-ended contracts

Project Architects-Engineers

McKinley & Associates



McKinley & Associates currently has **2 multiple year open-ended IDIQ agreements with the United States Postal Service**. One is for the **Appalachian Area** [Indefinite Quantity Contract 360070-15-J-0095, which includes the State of West Virginia, and 49 counties and/or independent cities in Virginia], which was just awarded on September 29, 2015, and is our **fourth consecutive** multiple year open-ended contract for WV. The second is for the **Erie/Pittsburgh District in Pennsylvania** (Indefinite Quantity Contract 362575-09-J-0232). We have designed **dozens of facilities** for the USPS, including **new construction, additions, renovations, and rehabilitations** in numerous cities within these areas, including **multiple boiler and HVAC projects**. Projects include **commissioning, testing and balancing**. One example project that is currently under construction is a \$1.8 million build-out / renovation project for the Parkersburg Carrier Annex & Hub, which includes **new HVAC systems, electrical, etc**. In addition, we have designed over 100 Postal facilities for ADA compliance. We have completed studies, reports, general building renovations, boilers/HVAC and electrical systems improvements, commissioning, utility infrastructure, roofs, elevators, landscaping, building envelope improvements, and much more. We have also completed Historic Preservation work, such as extensive interaction with The Secretary of the Interior's (NPS) Standards for the Treatment of Historic Properties and working with the Section 106 process required by SHPO and the Federal Department of the Interior. For the newest projects, they incorporate energy efficient design which follow the newest USPS Standards compliance to provide a more efficient systems. For example, the energy saving on a recent HVAC replacement project was achieved with the use of economizers to allow free cooling when ambient temperatures are below 60° F, and there was commissioning provided on the RTUs. We followed the USPS Standards, and we also completed Form ECC-EZ - Energy Compliance Certification for Low Energy-Impact R&A Projects.

A majority of the projects we have completed for the USPS over the past 20+ years have been various boiler and/or HVAC projects, including these recent examples which were all completed while the buildings remained occupied!:

- Altoona, PA Post Office - \$350,000 HVAC project involved Air Handling Units be replaced along with an addition of a DDC Control System in a historic 1931 facility.
- Charleston Processing & Distribution Center - \$375,000 HVAC renovation project involved replacing thermofusers and the ceiling fan coil units with 8 fan powered VAV boxes and 3 single duct VAV boxes with hot water reheat coils; replacing 3 failed rooftop units with new RTUs with electric heat and economizers; installing 2 new 5-ton mini split AC units in an area without cooling; and extending the existing DDC control system to control these new items.
- Clarksburg Finance Station - \$460,000 HVAC project involved the replacement of the outdated 120-ton water cooled chiller and two 107-ton cooling towers, with new energy efficient systems.
- Huntington Processing & Distribution Center - \$201,000 HVAC project replacing hot water boiler with like-in-kind.
- Martinsburg Processing & Distribution Center - \$280,000 HVAC project replacing 4 packaged rooftop units with new, like-in-kind, packaged rooftop units to bring the units in to USPS Standards compliance and to provide a more efficient system.
- Monongahela, PA Main Office - \$330,000 HVAC project replacing hot water boiler with 2 high efficiency condensing boilers in a historic 1913 facility; we recommended the most energy efficient solution that is life cycle cost effective over a 20-year period (with the upgrade from 83% to 95% efficient boilers the system operates more efficiently). While cutting the openings in the structural slab for the supply and return duct, the contractor created and/or noticed cracks; therefore we performed an emergency engineering site visit the next day on the condition of the concrete, provided a sketch for the required structural reinforcements, and the reinforcements were installed.
- Williamson Main Office - \$422,000 HVAC project replacing hot water boiler with high efficiency condensing boiler.

Beckley Veterans Affairs Medical Center

Beckley, West Virginia

Owner

Department of Veterans Affairs

Project Architects-Engineers

McKinley & Associates

Project Architect

Thomas R. Worledge,
AIA, LEED AP BD+C, REFP

Contractor

AAMC, Inc

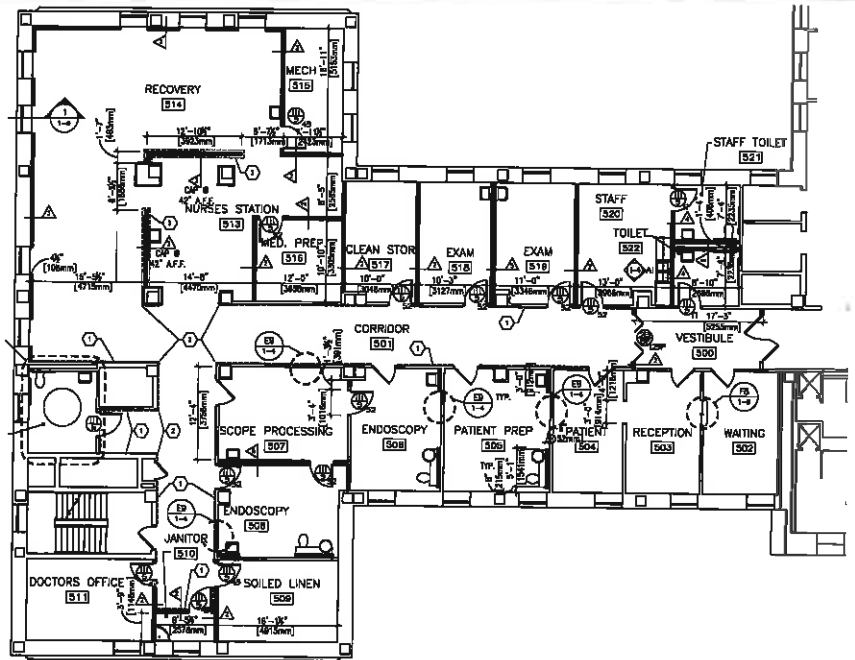

McKinley & Associates has completed over a dozen successful projects for six Veterans Affairs Medical Centers in West Virginia and Pennsylvania. For the VAMC in Beckley WV, we completed a Same Day Surgery Center & Recovery Suite, an Oncology Center, and more. These projects included a renovation of the central computer room, motion-sensing lighting controls, an addition for specialty clinics, and a renovation of recovery area for outpatient surgery. The Oncology renovation's scope of work was to renovate the existing Oncology Unit to provide additional square footage to the clinic stations for direct patient care privacy issues and upgrading their antiquated equipment. This Oncology Center is located on the first floor of their Medical Center Building 1. This included doctors offices, privacy exam/treatment rooms, the Oncology Manager's office, supply rooms, waiting room with receptionist area, staff areas, and multi-patient treatment rooms. The Oncology Center is a specialty area which is separated from rest of hospital; because of this, the patients had easy access, and they did not have to go through other clinics to get to it. Project included associated electrical and plumbing systems, and connecting tie-ins to existing systems. In addition to the Oncology Center, offices from their Police Section had to be relocated to their main building courtyard area. This included renovations, site preparation, concrete placement, structural installation, interior finishes, as well as mechanical

and electrical work. This included offices for the Chief of Police, the Assistant to the Chief, and future offices, a locker/break room, an operations area, weapons/storage room, and a holding cell. The Same Day Surgery Center & Recovery Suite involved relocating the existing library to the stage area behind the chapel. In that old library, we created a new Same Day Surgery Center & Recovery Suite with exam rooms, cleaning/prep areas, procedure rooms, doctors rooms, Nurses Station, patient waiting areas, counselling rooms, and more. This included HVAC, electrical, and plumbing systems. These projects added to the convenience of the spaces, and placed the treatment and the recovery areas on the same floor; therefore, it allowed the patients to feel more comfortable.

Dr. Ganzer Medical Office Building

Wheeling, West Virginia

Owner

Dr. Greg Ganzer

Size

15,000 SF

Construction Cost

\$1.5 million

Project Architects-Engineers

McKinley & Associates

Project Architect

Ray Winovich, RA

Contractor

Cattrell Companies

Renovations were performed on an old 3-story YMCA Building purchased by Dr. Ganzer. McKinley & Associates was responsible for all **Architecture and Engineering Design and Construction Administration** on this **15,000 SF Medical Office Building**. The project was completed in **two phases**, and included a **Medical Spa and Cosmetic Center, Medical Offices for Dermatology Practice, Exam Rooms, Treatment Rooms, a Nurse's Office and a Doctor's Office**. A new elevator was added, and the two stairwells were renovated. There was demolition of another building on the property, and a parking lot was designed. Skylights were used throughout the building to bring in natural daylighting.

The **first floor** includes 2 procedure rooms with casework and exam tables, a doctor's office with private restroom, nurse's room with private restroom, a light room with casework, a waiting room with reception area (which was to look business-like rather than medical, and included a plasma TV, modern high-quality furniture, and a fine coffee/beverage service counter), book keeping room, public restrooms, mechanics and electrical rooms, and room for future expansion. The **exam rooms, laser treatment room, and light room needed extra HVAC attention for exhaust air**.

The **second floor** includes 6 medical spa rooms, an office with private restroom, a consultant's room, a cosmetics room, waiting room, kitchen/lounge/break room, other private and public restrooms, and a storage area to name a few.



Dr. Don Chapman D.D.S.

Keep Smiling Family Dentistry Office

Wheeling, West Virginia

Owner

McKinley Properties, LLC

Size

3,620 SF (Phase 2 only)

Construction Cost

\$510,000 (Phase 2 only)

Project Architects-Engineers

McKinley & Associates

Project Architect

Christina Schessler, AIA, LEED AP BD+C

Contractor

Walters Construction

Dr. Don Chapman's Keep Smiling Family Dentistry Office opened in January 2013. This dental office suite is located in **Bennett Square**; which is a **historic** 3-story, 22,000 SF building (the old Ohio County Public Library Building) in Wheeling, WV. The rehabilitation of Bennett Square includes multiple phases, and this dental office was completed in Phase 2 of 3. Phase 1 houses "Class A" office space in beautifully restored surroundings.

The dental office is a fit-out on the second floor. Work included new and relocated equipment, an x-ray machine and dental chairs. Custom casework, track lighting, specialty HVAC, special electrical and data, special plumbing for gases and a central dental dry vacuum system were also integrated into the design. Planning for Dr. Chapman's office included business offices, exam/operatory rooms, hygienist room, x-ray room, sterilization room, lab, laundry, lounge and a waiting/reception area. We were able to highlight important architectural features while also providing a sensitive atmosphere for the patients. All of these spaces were integrated into an existing interior historic building context; the building is located in the Centre Market Square Historic District in the National Register of Historic Places.



WVSP Headquarters Data Center

South Charleston, West Virginia

Owner
West Virginia State Police

Construction Cost
\$350,000

Project Architects-Engineers
McKinley & Associates

Project Engineer
Darren S. Duskey, PE

Contractor
W. Harley Miller Contractors, Inc.

For over the past 19 years, McKinley & Associates has been honored to have been selected for multiple consecutive West Virginia State Police open-ended contracts for all engineering and architectural services throughout West Virginia. During this period we have been involved in **dozens** of projects with the WVSP. These projects included numerous renovations, additions, as well as new construction of multiple facilities throughout the State.

We recently completed upgrades on the State Police's main Data Center, located at their WVSP Headquarters in South Charleston, which included new service with a new generator and a new Uninterruptible Power Supply (UPS) for their main server room. Since the facility is the central hub of all police activity within the State, it must remain in operation 24/7; therefore, this emergency electric backup project was a priority project. This \$350,000 project included supplementing the existing 1600A, 208/120V service with a 480/277V feeder from a new service in the WVSP Headquarter's adjacent garage. The new 480/277V service has a generator which powers a panel in the main building's server room, which in turn feeds a UPS for the server, as well as a subpanel in the records room adjacent to the server room. The new emergency backup generator is a Cummins Model 400 DFEH series electric generating set rated for continuous standby service at 400 kW, 500 kVA Standby, at 0.8 PF, 277/480 volts 3 Phase 4 Wire, 60-Hz.

In addition, construction was recently completed on the new Logan Detachment, which is the Back-Up Data Center for that WVSP Headquarters facility; therefore, it needed much of the same emergency and power distribution systems. *More information is found on the following page.*

Furthermore, additional projects that were designed as E911 Centers for the State Police include their facilities in Berkeley, Doddridge, Mason and Pendleton Counties as well as the Morgantown Facility in Monongalia County. Each of these facilities included secured entrances, raised access floors, UPS, and emergency backup generators. They also included typical spaces such as Dispatch, Operations Mapping and Data Entry, Office and Conference Rooms. The Romney Detachment included a 1,000 SF 911 Center as part of the design. Although it was smaller than our normal 911 Center, it still included many of the same features mentioned above.

Before



and After



WVSP New Logan Detachment

Logan, West Virginia

Owner
West Virginia State Police

Size
13,000 SF approx.

Construction Cost
\$4.5 million

Project Architects-Engineers
McKinley & Associates

Project Architect
Thomas Worlledge, AIA, LEED AP BD+C, REFP

Contractor
W. Harley Miller Contractors, Inc.

As mentioned on the previous page, construction was recently completed on the new \$4.5 million Logan Detachment for the West Virginia State Police, which is the Back-Up Data Center for that WVSP Headquarters facility in South Charleston; therefore, it needed much of the same emergency and power distribution systems since the facility must remain in operation 24/7. For this Logan facility, we designed a 350 kW backup generator for the entire building, as well as Uninterruptible Power Supply (UPS) room, secured entrances, raised access floors, and more.

This building also includes a Dispatch Center with a dispatch room, radio room, and a computer rooms with raised access floors. Furthermore, the detachment has a District Commander's office, Detachment Commander's office, Assistant Commanders' offices, Lieutenant Inspector office, Lieutenant offices, squad bay for 25 Troopers w/workstations, receptionist area, file rooms, dayroom, evidence room, 30 trooper lockers, conference rooms, processing room, witness interview room, two-bay garage, and more. There are multiple **energy-efficient** and **sustainable design** aspects to the building: The Detachment uses a daylight clearstory to let natural daylight into the internal squad and conference rooms. The HVAC System included the installation of 2 high efficiency condensing boilers, pumps with variable speed drive control, custom air handling unit with dx (remote condensing unit) and hot water coils, variable air volume boxes with hot water heating coils, computer room units with remote

condensing units, and direct digital controls. This is the first time Insulated Concrete Forms (ICFs) have been used for State Police Buildings; ICFs are an almost perfect fit since they are cost effective to construct, energy efficient, and secure.



2 Generator Projects

Washington, Pennsylvania

Owner

Washington & Jefferson College

Size

Multiple Buildings

Project Architects-Engineers

McKinley & Associates

Project Engineer

Darren S. Duskey, PE

McKinley & Associates is working with Washington & Jefferson College on many projects, and on multiple buildings around their campus.

One project is a major emergency generator installation project with an elevated structural steel platform at their Commons building. This natural gas emergency power generators will provide backup power for egress lighting, life safety systems, and other mission critical processes. This project required electrical, mechanical and civil engineering services. The Commons was originally constructed in 1967, is approximately 32,613 SF, and serves as the main kitchen and dining hall for the College. There is a radio station, coffee shop, student organizational space, and meeting space. There is also some critical network equipment located in this facility. It is the intent of the college that this space be used to provide food and shelter in the event an emergency. The 500 kW generator was designed to support egress lighting and life safety systems, as well as serve as backup power necessary to maintain food stores, prepare and serve food, provide heat for shelter, and, finally, serve as a campus operations center should one become necessary. Project included new transfer switches, panels, feeds, and lighting. In addition, the project included demo and excavation, as well as the addition of a concrete pad and retaining wall.

For another project, we also designed an emergency generator installation project at their administration building Thompson Hall. This natural gas emergency power generators will provide backup power for egress lighting, life safety systems, and other mission critical processes. This project required electrical, mechanical and civil engineering services, and we provided design development, construction documentation, CAD drawing construction administration, quality control and closeout. The 14,530 SF Thompson Hall was originally constructed in

1913 as the Library, and now houses offices for Business and Finance, Academic Affairs, and the Registrar. It is also the location of critical network switching equipment and a Data Center. The generator was designed to support egress lighting and life safety systems, as well as serve as backup power for the network equipment and ancillary HVAC housed there.

Additional responsibilities for BOTH projects included researching current loads and projected loads and make recommendations for proper generator sizing, preparing an order of magnitude budget at various phases of design, developing a pre-purchase specification for the direct purchase of generators by the College (*the purpose of direct purchase was to reduce cost and lead time*), making recommendations for generator placement giving consideration to cost benefit and reducing overall impact to the campus environment, and being responsible for utility coordination and the procurement of applicable permits.

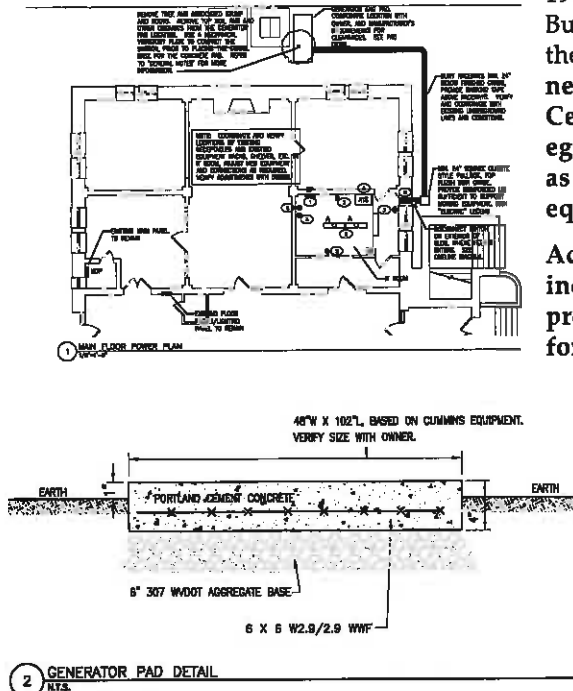
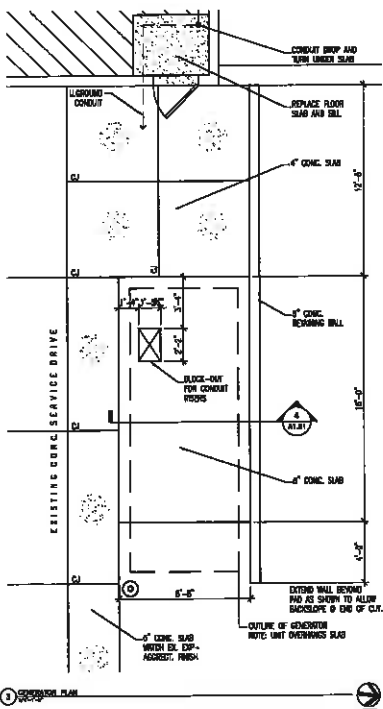
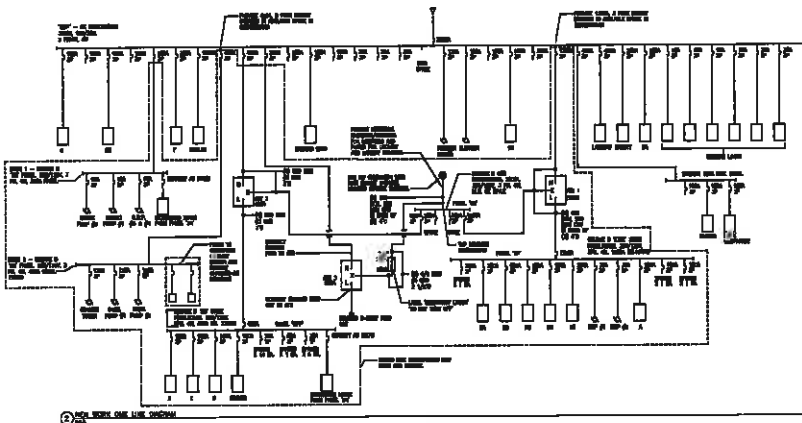

The Ryan Ferns HealthPlex

Benwood, West Virginia

Owner
Dr. Ryan Ferns

Size
11,670 SF

Project Architects-Engineers
McKinley & Associates

Project Architect
Michael S. Betsch, AIA, LEED AP

This project is a **renovation/adaptive reuse** of an old furniture store located in a shopping center, into a new **multi-purpose Health Complex facility**. This is a 24 Hour Fitness Center, a CrossFit Training facility, and a **Physical Therapy Clinic** all-in-one. This project was designed with ADA compliance, **electrical, HVAC/mechanical, & plumbing** systems. It was fast-tracked to meet the Owner's move-in requirements of Sept. 2012.

The **24/7 Wellness/Fitness areas** include an indoor walking track, exercise equipment rooms (cardio, strength training machines, free weights, etc.), "open" group exercise rooms (for cross fit, zumba, boot camp, etc.), and locker rooms. We had to design the exercise rooms to fit their equipment needs. There are rubber floors and 14' ceilings throughout. The Men's and Women's locker rooms both have 2 private showers, multiple lockers, and restrooms. One unique feature is the entrance to this area has an **air curtain**, which is **designed to prevent the penetration of outside, unconditioned air** (prevents hot or cold air from entering, as well as flying insects, dirt, etc.), while at the same time **circulates and maintains the inside conditioned air**, which stabilizes the environment and **eliminates hot/cold spots near building entryways, helps with energy savings, improves sanitation levels, and increases comfort for customers and employees.**

The **Physical Therapy Clinic** includes a reception area, 2 offices, **3 evaluation/examination rooms**, a break room/conference room, an "open" work room, laundry, restrooms, and more. This has a separate entry, since it has hours of operation (it isn't open 24-hours like the other areas). We **custom-designed** the reception desk, casework, cabinetry, and more. In addition, a **42' x 42' therapy area** is adjacent, and has treatment tables, physical therapy supplies (exercise balls, balance equipment, etc.), and we designed the space to include their new HydroWorx 500 Series pool with an underwater treadmill and underwater camera with LED display. **From this, we designed the HVAC to have a special dehumidification unit for the therapy pool room.** There is an adjacent toilet/locker room to the therapy area, and a toilet/shower/locker room adjacent to the therapy pool area.



Before



After

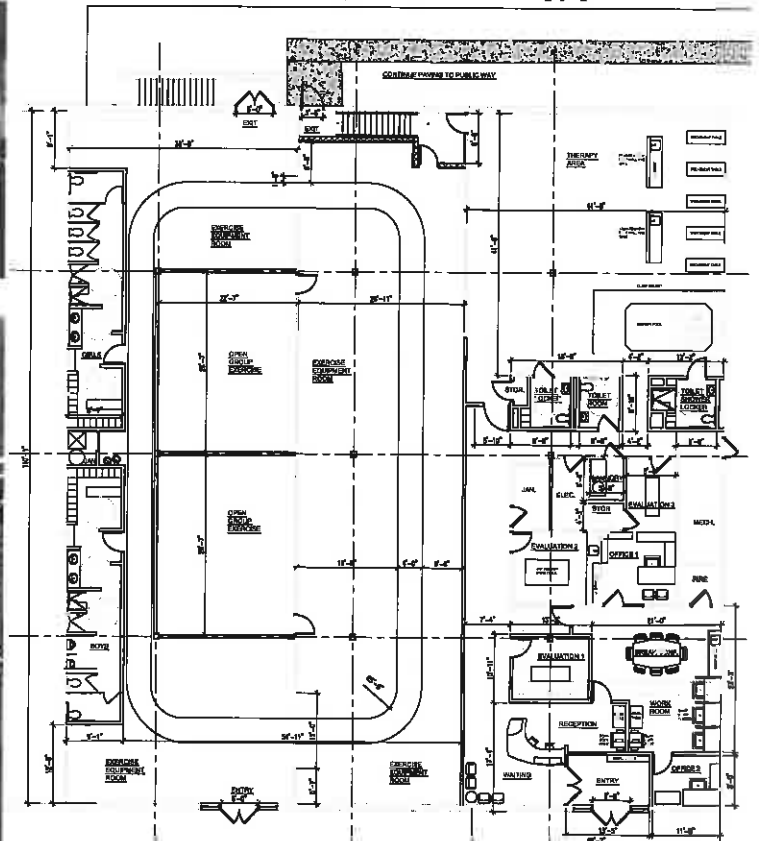

Hancock County Schools

Weirton Elementary & Health Center

Weirton, West Virginia

Owner
Hancock County Schools

Size
105,000+ SF

Construction Cost
\$26.5 million

Project Architects-Engineers
McKinley & Associates

Project Architect
Gregg P. Dorfner, AIA, NCARB

Contractor
Cattrell Companies, Inc.

Construction Manager
PICIS

The new \$26.5 million, 105,000 SF Weirton Elementary School for 950 students in grades PK-4 was recently completed on-schedule for the start of the 2014-15 year. This is the largest elementary school designed in West Virginia. We incorporated **multiple "High Performance School" and energy efficient MEP engineering components** into this building. These include **high efficiency boilers, energy recovery wheel, desiccant wheel, chilled beam system, Variable Frequency Controllers to reduce fan energy, low flow plumbing fixtures, energy monitor on the main electrical gear, dimmable lighting with occupancy sensor control, and T-5 & T-5 HO fluorescent bulbs** used as primary light sources throughout school to name a few. All of this has been accomplished with less than 1% in non-elective change orders!

The school houses the first school-based health center in the Northern Panhandle, which is operated by C.H.A.N.G.E., Inc.'s Family Medical Care, a Federally Qualified Health Center. We designed the layout, as well as the casework (example seen below). The 2,132 SF center features several exam rooms and will provide pupils with limited treatment when necessary, including wellness checks, primary care, dental screening immunizations and behavioral health counseling. No pupil will be sent to the health center without express written permission from a parent. Primary Care services include well-child visits, treatment of illness or injury, immunizations, prescription medications, health education & counseling, as well as fitness & nutrition education. Dental Health services include oral screenings, dental education and preventative care. Mental Health services include anger management, anxiety, crisis intervention, childhood behavior & academic problems, depression, family conflict, therapy, grief counseling, medication management, sleep problems, and substance abuse.

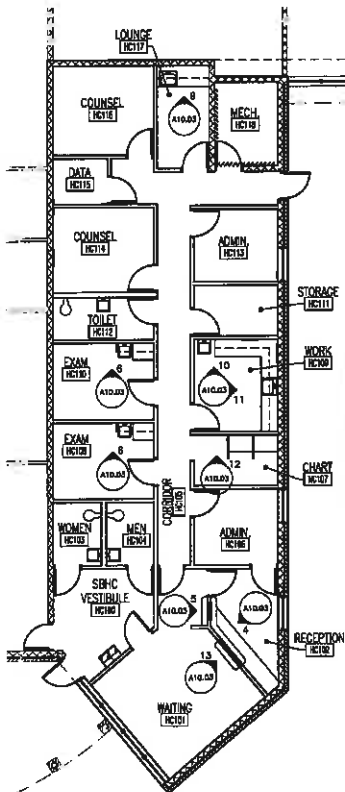



Purchasing Division
 2019 Washington Street East
 Post Office Box 50130
 Charleston, WV 25305-0130

State of West Virginia
 Centralized Expression of Interest
 02 - Architect/Engr

Proc Folder: 211903

Doc Description: EOI for professional engineering services

Proc Type: Central Purchase Order

Date Issued	Solicitation Closes	Solicitation No	Version
2016-07-26	2016-08-30 13:30:00	CEOI 0506 HHR1700000001	1

BID RECEIVING LOCATION

BID CLERK
 DEPARTMENT OF ADMINISTRATION
 PURCHASING DIVISION
 2019 WASHINGTON ST E
 CHARLESTON WV 25305
 US

VENDOR

Vendor Name, Address and Telephone Number:

*000000206862
 McKinley & Associates, Inc.
 32 20th Street - Suite 100
 Wheeling, WV 26003
 304 / 233-0140

FOR INFORMATION CONTACT THE BUYER

Jessica S Chambers
 (304) 558-0246
 jessica.s.chambers@wv.gov

Signature X

FEIN # 55-0696478

DATE August 25, 2016

All offers subject to all terms and conditions contained in this solicitation

DESIGNATED CONTACT: Vendor appoints the individual identified in this Section as the Contract Administrator and the initial point of contact for matters relating to this Contract.

Ernest Dellatorre - President
 (Name, Title)
Ernest Dellatorre, President
 (Printed Name and Title)
32 20th Street - Suite 100, Wheeling, WV 26003
 (Address)
(304) 233-0140 | (304) 233-4613
 (Phone Number) / (Fax Number)
edellatorre@mckinleyassoc.com
 (email address)

CERTIFICATION AND SIGNATURE: By signing below, or submitting documentation through wvOASIS, I certify that I have reviewed this Solicitation in its entirety; that I understand the requirements, terms and conditions, and other information contained herein; that this bid, offer or proposal constitutes an offer to the State that cannot be unilaterally withdrawn; that the product or service proposed meets the mandatory requirements contained in the Solicitation for that product or service, unless otherwise stated herein; that the Vendor accepts the terms and conditions contained in the Solicitation, unless otherwise stated herein; that I am submitting this bid, offer or proposal for review and consideration; that I am authorized by the vendor to execute and submit this bid, offer, or proposal, or any documents related thereto on vendor's behalf; that I am authorized to bind the vendor in a contractual relationship; and that to the best of my knowledge, the vendor has properly registered with any State agency that may require registration.

McKinley & Associates
 (Company)
Ernest Dellatorre - President
 (Authorized Signature) (Representative Name, Title)
Ernest Dellatorre, President
 (Printed Name and Title of Authorized Representative)
August 25, 2016
 (Date)
(304) 233-0140 | (304) 233-4613
 (Phone Number) (Fax Number)

PURCHASING AFFIDAVIT

MANDATE: Under W. Va. Code §5A-3-10a, no contract or renewal of any contract may be awarded by the state or any of its political subdivisions to any vendor or prospective vendor when the vendor or prospective vendor or a related party to the vendor or prospective vendor is a debtor and: (1) the debt owed is an amount greater than one thousand dollars in the aggregate; or (2) the debtor is in employer default.

EXCEPTION: The prohibition listed above does not apply where a vendor has contested any tax administered pursuant to chapter eleven of the W. Va. Code, workers' compensation premium, permit fee or environmental fee or assessment and the matter has not become final or where the vendor has entered into a payment plan or agreement and the vendor is not in default of any of the provisions of such plan or agreement.

DEFINITIONS:

"Debt" means any assessment, premium, penalty, fine, tax or other amount of money owed to the state or any of its political subdivisions because of a judgment, fine, permit violation, license assessment, defaulted workers' compensation premium, penalty or other assessment presently delinquent or due and required to be paid to the state or any of its political subdivisions, including any interest or additional penalties accrued thereon.

"Employer default" means having an outstanding balance or liability to the old fund or to the uninsured employers' fund or being in policy default, as defined in W. Va. Code § 23-2c-2, failure to maintain mandatory workers' compensation coverage, or failure to fully meet its obligations as a workers' compensation self-insured employer. An employer is not in employer default if it has entered into a repayment agreement with the Insurance Commissioner and remains in compliance with the obligations under the repayment agreement.

"Related party" means a party, whether an individual, corporation, partnership, association, limited liability company or any other form or business association or other entity whatsoever, related to any vendor by blood, marriage, ownership or contract through which the party has a relationship of ownership or other interest with the vendor so that the party will actually or by effect receive or control a portion of the benefit, profit or other consideration from performance of a vendor contract with the party receiving an amount that meets or exceeds five percent of the total contract amount.

AFFIRMATION: By signing this form, the vendor's authorized signer affirms and acknowledges under penalty of law for false swearing (W. Va. Code §61-5-3) that neither vendor nor any related party owe a debt as defined above and that neither vendor nor any related party are in employer default as defined above, unless the debt or employer default is permitted under the exception above.

WITNESS THE FOLLOWING SIGNATURE:

Vendor's Name: McKinley & Associates

Authorized Signature: *[Signature]* Date: August 25, 2016

State of West Virginia

County of Ohio, to-wit:

Taken, subscribed, and sworn to before me this 25 day of August, 2016.

My Commission expires June 26, 2024.

FIX SEAL HERE

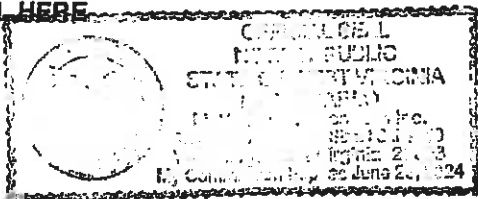

NOTARY PUBLIC

[Signature]

State of West Virginia

VENDOR PREFERENCE CERTIFICATE

Certification and application* is hereby made for Preference in accordance with *West Virginia Code*, §5A-3-37. (Does not apply to construction contracts). *West Virginia Code*, §5A-3-37, provides an opportunity for qualifying vendors to request (at the time of bid) preference for their residency status. Such preference is an evaluation method only and will be applied only to the cost bid in accordance with the *West Virginia Code*. This certificate for application is to be used to request such preference. The Purchasing Division will make the determination of the Vendor Preference, if applicable.

1. **Application is made for 2.5% vendor preference for the reason checked:**
 Bidder is an individual resident vendor and has resided continuously in West Virginia for four (4) years immediately preceding the date of this certification; or,
 Bidder is a partnership, association or corporation resident vendor and has maintained its headquarters or principal place of business continuously in West Virginia for four (4) years immediately preceding the date of this certification; or 80% of the ownership interest of Bidder is held by another individual, partnership, association or corporation resident vendor who has maintained its headquarters or principal place of business continuously in West Virginia for four (4) years immediately preceding the date of this certification; or,
 Bidder is a nonresident vendor which has an affiliate or subsidiary which employs a minimum of one hundred state residents and which has maintained its headquarters or principal place of business within West Virginia continuously for the four (4) years immediately preceding the date of this certification; or,
2. **Application is made for 2.5% vendor preference for the reason checked:**
 Bidder is a resident vendor who certifies that, during the life of the contract, on average at least 75% of the employees working on the project being bid are residents of West Virginia who have resided in the state continuously for the two years immediately preceding submission of this bid; or,
3. **Application is made for 2.5% vendor preference for the reason checked:**
 Bidder is a nonresident vendor employing a minimum of one hundred state residents or is a nonresident vendor with an affiliate or subsidiary which maintains its headquarters or principal place of business within West Virginia employing a minimum of one hundred state residents who certifies that, during the life of the contract, on average at least 75% of the employees or Bidder's affiliate's or subsidiary's employees are residents of West Virginia who have resided in the state continuously for the two years immediately preceding submission of this bid; or,
4. **Application is made for 5% vendor preference for the reason checked:**
 Bidder meets either the requirement of both subdivisions (1) and (2) or subdivision (1) and (3) as stated above; or,
5. **Application is made for 3.5% vendor preference who is a veteran for the reason checked:**
 Bidder is an individual resident vendor who is a veteran of the United States armed forces, the reserves or the National Guard and has resided in West Virginia continuously for the four years immediately preceding the date on which the bid is submitted; or,
6. **Application is made for 3.5% vendor preference who is a veteran for the reason checked:**
 Bidder is a resident vendor who is a veteran of the United States armed forces, the reserves or the National Guard, if, for purposes of producing or distributing the commodities or completing the project which is the subject of the vendor's bid and continuously over the entire term of the project, on average at least seventy-five percent of the vendor's employees are residents of West Virginia who have resided in the state continuously for the two immediately preceding years.
7. **Application is made for preference as a non-resident small, women- and minority-owned business, in accordance with *West Virginia Code* §5A-3-59 and *West Virginia Code of State Rules*.**
 Bidder has been or expects to be approved prior to contract award by the Purchasing Division as a certified small, women- and minority-owned business.

Bidder understands if the Secretary of Revenue determines that a Bidder receiving preference has failed to continue to meet the requirements for such preference, the Secretary may order the Director of Purchasing to: (a) reject the bid; or (b) assess a penalty against such Bidder in an amount not to exceed 5% of the bid amount and that such penalty will be paid to the contracting agency or deducted from any unpaid balance on the contract or purchase order.

By submission of this certificate, Bidder agrees to disclose any reasonably requested information to the Purchasing Division and authorizes the Department of Revenue to disclose to the Director of Purchasing appropriate information verifying that Bidder has paid the required business taxes, provided that such information does not contain the amounts of taxes paid nor any other information deemed by the Tax Commissioner to be confidential.

Under penalty of law for false swearing (*West Virginia Code*, §61-5-3), Bidder hereby certifies that this certificate is true and accurate in all respects; and that if a contract is issued to Bidder and if anything contained within this certificate changes during the term of the contract, Bidder will notify the Purchasing Division in writing immediately.

Bidder: McKinley & Associates

Signed: 

Date: August 25, 2016

Title: President

WV Licenses & Registrations

For your convenience, you will see copies of our key individual's and firm's various licenses & registrations as evidence that we are currently registered in the State of West Virginia.

On this page is Tim Mizer's (*your Project Manager / lead Engineer*) West Virginia State Board of Registration for Professional Engineers (WV PE #013169).



On the following page is Thom Worlledge's (*your lead Architect*) Registration and Authorization to Practice Architecture in West Virginia (Certificate #2874).

We would be happy to provide you with copies of other Professionals' licenses if you wish to see them.

In addition, a listing of all the professionals' certifications, degrees, and licenses are found on their resumes in the "Design Team" tab.

Furthermore, on the following pages, you will see our firm's Certificate of Incorporation, Certificate of Good Standing, Business Registration Certificate, and Certificate of Authorization for providing Engineering Services in West Virginia.

WV Licenses & Registrations

The West Virginia Board of Architects

certifies that

THOMAS R. WORLLEDGE

is registered and authorized to practice
Architecture in the State of West Virginia.

In testimony whereof this certificate has been issued
by the authority of this board.

Certificate Number 2874

The registration is in good standing until June 30, 2017.



Lepa C. Lewis

Board Administrator

WV Licenses & Registrations

BOOK 66 PAGE 793



CERTIFICATE

I, Ken Hechler, Secretary of State of the State of West Virginia, hereby certify that

by the provisions of Chapter 31, Article 1, Sections 27 and 28 of the West Virginia Code, the Articles of Incorporation of

McKINLEY & ASSOCIATES, INC.

conform to law and are filed in my office. I therefore declare the organization to be a Corporation for the purposes set forth in its Articles, with the right of perpetual existence, and I issue this

CERTIFICATE OF INCORPORATION

to which I have attached a duplicate original of the Articles of Incorporation.

Given under my hand and the Great Seal of the State of West Virginia, on this

FIFTEENTH day of

DECEMBER 19 89

Ken Hechler

Secretary of State.



WV Licenses & Registrations

State of West Virginia

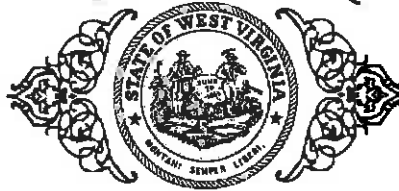

Certificate

*I, Natalie E. Tennant, Secretary of State of the
State of West Virginia, hereby certify that*

MCKINLEY & ASSOCIATES, INC.

was incorporated under the laws of West Virginia and a Certificate of Incorporation was issued by the West Virginia Secretary of State's Office on December 15, 1989.

I further certify that the corporation has not been revoked by the State of West Virginia nor has the West Virginia Secretary of State issued a Certificate of Dissolution to the corporation.

Accordingly, I hereby issue this

CERTIFICATE OF EXISTENCE

Validation ID:0WV3W_CQTDH



*Given under my hand and the
Great Seal of the State of
West Virginia on this day of
October 27, 2015*

Natalie E. Tennant

Secretary of State

Notice: A certificate issued electronically from the West Virginia Secretary of State's Web site is fully and immediately valid and effective. However, as an option, the issuance and validity of a certificate obtained electronically may be established by visiting the Certificate Validation Page of the Secretary of State's Web site, <https://apps.wv.gov/sos/businessentitysearch/validate.aspx> entering the validation ID displayed on the certificate, and following the instructions displayed. Confirming the issuance of a certificate is merely optional and is not necessary to the valid and effective issuance of a certificate.

WV Licenses & Registrations

**WEST VIRGINIA
STATE TAX DEPARTMENT
BUSINESS REGISTRATION
CERTIFICATE**

ISSUED TO:
**MCKINLEY & ASSOCIATES INC
32 20TH ST
WHEELING, WV 26003-3750**

BUSINESS REGISTRATION ACCOUNT NUMBER: **1040-9524**

This certificate is issued on: **06/28/2011**

*This certificate is issued by
the West Virginia State Tax Commissioner
in accordance with Chapter 11, Article 12, of the West Virginia Code*

*The person or organization identified on this certificate is registered
to conduct business in the State of West Virginia at the location above.*

This certificate is not transferrable and must be displayed at the location for which issued.

This certificate shall be permanent until cessation of the business for which the certificate of registration was granted or until it is suspended, revoked or cancelled by the Tax Commissioner.

Change in name or change of location shall be considered a cessation of the business and a new certificate shall be required.

**TRAVELING/STREET VENDORS: Must carry a copy of this certificate in every vehicle operated by them.
CONTRACTORS, DRILLING OPERATORS, TIMBER/LOGGING OPERATIONS: Must have a copy of
this certificate displayed at every job site within West Virginia.**

atl.008 v.4
L0538442304



MCKINLEY & ASSOCIATES
ARCHITECTS • ENGINEERS • INTERIOR DESIGN

WV Licenses & Registrations

CERTIFICATE OF

Authorization

STATE BOARD OF REGISTRATION FOR PROFESSIONAL ENGINEERS

*The West Virginia State Board of Registration for Professional Engineers
having verified the person in responsible charge is registered in
West Virginia as a professional engineer for the noted firm, hereby certifies*

MCKINLEY & ASSOCIATES, INC.

C00366-00

Engineer in Responsible Charge: TIM E MIZER - WV PE 013169

*has complied with section §30-13-17 of the West Virginia Code governing
the issuance of a Certificate of Authorization. The Board hereby notifies you of its
certification with issuance of this Certification of Authorization for the period of:*

January 1, 2015 - December 31, 2017

providing for the practice of engineering services in the State of West Virginia.

IF YOU ARE REQUIRED TO REGISTER WITH THE SECRETARY OF STATE'S OFFICE,
PLEASE SUBMIT THIS CERTIFICATE WITH YOUR APPLICATION.



IN TESTIMONY WHEREOF, THE WEST VIRGINIA STATE BOARD OF
REGISTRATION FOR PROFESSIONAL ENGINEERS HAS ISSUED THIS COA
UNDER ITS SEAL AND SIGNED BY THE PRESIDENT OF SAID BOARD.

BOARD PRESIDENT



McKINLEY & ASSOCIATES
ARCHITECTS • ENGINEERS • INTERIOR DESIGN

Insurance

Per your request, you will find copies of our various Insurance Coverages, including Commercial General Liability, Aggregate General Liability, Automobile Liability, and WV Statutory Requirements including WV Code 23-4-2 (Mandolidis) found on this page, as well as Professional Liability on the following page.

ACORD™		CERTIFICATE OF LIABILITY INSURANCE			DATE (MM/DD/YYYY) 05/02/2016		
THIS CERTIFICATE IS ISSUED AS A MATTER OF INFORMATION ONLY AND CONFERS NO RIGHTS UPON THE CERTIFICATE HOLDER. THIS CERTIFICATE DOES NOT AFFIRMATIVELY OR NEGATIVELY AMEND, EXTEND OR ALTER THE COVERAGE AFFORDED BY THE POLICIES BELOW. THIS CERTIFICATE OF INSURANCE DOES NOT CONSTITUTE A CONTRACT BETWEEN THE ISSUING INSURER(S), AUTHORIZED REPRESENTATIVE OR PRODUCER, AND THE CERTIFICATE HOLDER.							
IMPORTANT: If the certificate holder is an ADDITIONAL INSURED, the policy(ies) must be endorsed. If SUBROGATION IS WAIVED, subject to the terms and conditions of the policy, certain policies may require an endorsement. A statement on this certificate does not confer rights to the certificate holder in lieu of such endorsement(s).							
PRODUCER Paul Associates 1311 Chapline Street P. O. Box 990 Wheeling, WV 26003-0123			CONTACT NAME: III, Lee Paul PHONE (A/C, No., Ext): 304.233.3303 FAX (A/C, No.): 304.233.3333 E-MAIL ADDRESS: PRODUCER CUSTOMER ID#:				
INSURED McKinley & Associates, Inc. The Maxwell Centre 32-20th Street Wheeling, WV 26003			INSURER(S) AFFORDING COVERAGE		NAIC #		
			INSURER A: Cincinnati Insurance Co.		10677		
			INSURER B: Brickstreet Ins		Brick		
			INSURER C:				
			INSURER D:				
			INSURER E:				
			INSURER F:				
COVERAGES CERTIFICATE NUMBER: 15/18 Liab w/workers comp REVISION NUMBER:							
THIS IS TO CERTIFY THAT THE POLICIES OF INSURANCE LISTED BELOW HAVE BEEN ISSUED TO THE INSURED NAMED ABOVE FOR THE POLICY PERIOD INDICATED. NOTWITHSTANDING ANY REQUIREMENT, TERM OR CONDITION OF ANY CONTRACT OR OTHER DOCUMENT WITH RESPECT TO WHICH THIS CERTIFICATE MAY BE ISSUED OR MAY PERTAIN, THE INSURANCE AFFORDED BY THE POLICIES DESCRIBED HEREIN IS SUBJECT TO ALL THE TERMS, EXCLUSIONS AND CONDITIONS OF SUCH POLICIES. LIMITS SHOWN MAY HAVE BEEN REDUCED BY PAID CLAIMS.							
INSR LTR	TYPE OF INSURANCE	ADDL INSR	WVD	POLICY NUMBER	POLICY EFF (MM/DD/YYYY)	POLICY EXP (MM/DD/YYYY)	LIMITS
A	GENERAL LIABILITY			EPP0146335	06/15/2015	06/15/2018	EACH OCCURRENCE \$ 1,000,000
	<input checked="" type="checkbox"/> COMMERCIAL GENERAL LIABILITY						DAMAGE TO RENTED PREMISES (Ea occurrence) \$ 500,000
	<input type="checkbox"/> CLAIMS-MADE <input checked="" type="checkbox"/> OCCUR						MED EXP (Any one person) \$ 10,000
	GENL AGGREGATE LIMIT APPLIES PER:						
	<input type="checkbox"/> POLICY <input type="checkbox"/> PRO-JECT <input type="checkbox"/> LOC						GENERAL AGGREGATE \$ 2,000,000
							PRODUCTS - COM/PO/ AGG \$ 2,000,000
A	AUTOMOBILE LIABILITY			EPP0146335	06/15/2015	06/15/2018	COMBINED SINGLE LIMIT (Ea accident) \$ 1,000,000
	<input type="checkbox"/> ANY AUTO						BODILY INJURY (Per person) \$
	<input type="checkbox"/> ALL OWNED AUTOS						BODILY INJURY (Per accident) \$
	<input type="checkbox"/> SCHEDULED AUTOS						PROPERTY DAMAGE (Per accident) \$
	<input checked="" type="checkbox"/> HIRED AUTOS						\$
<input checked="" type="checkbox"/> NON-OWNED AUTOS						\$	
A	UMBRELLA LIAB			EPP0146335	06/15/2015	06/15/2018	EACH OCCURRENCE \$ 1,000,000
	<input checked="" type="checkbox"/> OCCUR						AGGREGATE \$ 1,000,000
	<input type="checkbox"/> EXCESS LIAB						\$
	<input type="checkbox"/> CLAIMS-MADE						\$
	DEDUCTIBLE						\$
	RETENTION \$						\$
B	WORKERS COMPENSATION AND EMPLOYERS' LIABILITY			WCB1018014	12/30/2015	12/30/2016	WC STATUTORY LIMITS
	ANY PROPRIETOR/PARTNER/EXECUTIVE OFFICER/MEMBER EXCLUDED? (Mandatory in NH) If yes, describe under DESCRIPTION OF OPERATIONS below		N/A	WV DELIBERATE INTENT COVERAGE INCLUDED "MANDOLIDIS"			OTH-ER
							E.L. EACH ACCIDENT \$ 1,000,000
							E.L. DISEASE - EA EMPLOYEE \$ 1,000,000
							E.L. DISEASE - POLICY LIMIT \$ 1,000,000
DESCRIPTION OF OPERATIONS / LOCATIONS / VEHICLES (Attach ACORD 101, Additional Remarks Schedule, if more space is required) Specimen copy to be held by McKinley and Associates.							
CERTIFICATE HOLDER				CANCELLATION			
Specimen				SHOULD ANY OF THE ABOVE DESCRIBED POLICIES BE CANCELLED BEFORE THE EXPIRATION DATE THEREOF, NOTICE WILL BE DELIVERED IN ACCORDANCE WITH THE POLICY PROVISIONS.			
				AUTHORIZED REPRESENTATIVE <i>Lee C Paul III 5/2/2016</i>			
ACORD 25 (2009/08)				© 1988-2009 ACORD CORPORATION. All rights reserved.			
				The ACORD name and logo are registered marks of ACORD			

Insurance



CERTIFICATE OF LIABILITY INSURANCE

DATE (MM/DD/YYYY)
10/9/2015

THIS CERTIFICATE IS ISSUED AS A MATTER OF INFORMATION ONLY AND CONFERS NO RIGHTS UPON THE CERTIFICATE HOLDER. THIS CERTIFICATE DOES NOT AFFIRMATIVELY OR NEGATIVELY AMEND, EXTEND OR ALTER THE COVERAGE AFFORDED BY THE POLICIES BELOW. THIS CERTIFICATE OF INSURANCE DOES NOT CONSTITUTE A CONTRACT BETWEEN THE ISSUING INSURER(S), AUTHORIZED REPRESENTATIVE OR PRODUCER, AND THE CERTIFICATE HOLDER.

IMPORTANT: If the certificate holder is an ADDITIONAL INSURED, the policy(ies) must be endorsed. If SUBROGATION IS WAIVED, subject to the terms and conditions of the policy, certain policies may require an endorsement. A statement on this certificate does not confer rights to the certificate holder in lieu of such endorsement(s).

PRODUCER The James B. Oswald Company 1100 Superior Avenue, Suite 1500 Cleveland OH 44114	CONTACT NAME: Patricia Cholewa	
	PHONE (A/C No. Ext): 216-839-2807	FAX (A/C No.):
E-MAIL ADDRESS: PCholewa@oswaldcompanies.com		
INSURER(S) AFFORDING COVERAGE		NAIC #
INSURER A: Continental Casualty Co.		18313
INSURER B:		
INSURER C:		
INSURER D:		
INSURER E:		
INSURER F:		

INSURED MCKIN-1
 McKinley & Associates, Inc.
 32 20th Street #100
 Wheeling WV 26003

COVERAGES **CERTIFICATE NUMBER:** 149514368 **REVISION NUMBER:**

THIS IS TO CERTIFY THAT THE POLICIES OF INSURANCE LISTED BELOW HAVE BEEN ISSUED TO THE INSURED NAMED ABOVE FOR THE POLICY PERIOD INDICATED. NOTWITHSTANDING ANY REQUIREMENT, TERM OR CONDITION OF ANY CONTRACT OR OTHER DOCUMENT WITH RESPECT TO WHICH THIS CERTIFICATE MAY BE ISSUED OR MAY PERTAIN, THE INSURANCE AFFORDED BY THE POLICIES DESCRIBED HEREIN IS SUBJECT TO ALL THE TERMS, EXCLUSIONS AND CONDITIONS OF SUCH POLICIES. LIMITS SHOWN MAY HAVE BEEN REDUCED BY PAID CLAIMS.

INSR LTR	TYPE OF INSURANCE	ADDL SUBR INSR WVD	POLICY NUMBER	POLICY EFF (MM/DD/YYYY)	POLICY EXP (MM/DD/YYYY)	LIMITS
	GENERAL LIABILITY <input type="checkbox"/> COMMERCIAL GENERAL LIABILITY <input type="checkbox"/> CLAIMS-MADE <input type="checkbox"/> OCCUR GENL AGGREGATE LIMIT APPLIES PER: <input type="checkbox"/> POLICY <input type="checkbox"/> PRO-JECT <input type="checkbox"/> LOC					EACH OCCURRENCE \$ DAMAGE TO RENTED PREMISES (Ea occurrence) \$ MED EXP (Any one person) \$ PERSONAL & ADV INJURY \$ GENERAL AGGREGATE \$ PRODUCTS - COM/POP AGG \$
	AUTOMOBILE LIABILITY <input type="checkbox"/> ANY AUTO <input type="checkbox"/> ALL OWNED AUTOS <input type="checkbox"/> SCHEDULED AUTOS <input type="checkbox"/> HIRED AUTOS <input type="checkbox"/> NON-OWNED AUTOS					COMBINED SINGLE LIMIT (Ea accident) \$ BODILY INJURY (Per person) \$ BODILY INJURY (Per accident) \$ PROPERTY DAMAGE (Per accident) \$
	UMBRELLA LIAB <input type="checkbox"/> OCCUR EXCESS LIAB <input type="checkbox"/> CLAIMS-MADE DED \$ RETENTION \$					EACH OCCURRENCE \$ AGGREGATE \$
	WORKERS COMPENSATION AND EMPLOYERS' LIABILITY ANY PROPRIETOR/PARTNER/EXECUTIVE OFFICER/MEMBER EXCLUDED? (Mandatory in NH) If yes, describe under DESCRIPTION OF OPERATIONS below	Y/N	N/A			WC STATUTORY LIMITS OTH-ER E.L. EACH ACCIDENT \$ E.L. DISEASE - EA EMPLOYEE \$ E.L. DISEASE - POLICY LIMIT \$
A	Professional Liability Claims Made Retro Date: 9/10/1981	N Y	AEH591893924	10/10/2015	10/10/2016	Each Claim \$1,000,000 Aggregate \$1,000,000

DESCRIPTION OF OPERATIONS / LOCATIONS / VEHICLES (Attach ACORD 101, Additional Remarks Schedule, if more space is required)

Waiver of Subrogation as designated above is provided when required of the Named Insured by written contract or agreement.

CERTIFICATE HOLDER Specimen For Purposes of Evidencing Coverage Only WV 26003	CANCELLATION SHOULD ANY OF THE ABOVE DESCRIBED POLICIES BE CANCELLED BEFORE THE EXPIRATION DATE THEREOF, NOTICE WILL BE DELIVERED IN ACCORDANCE WITH THE POLICY PROVISIONS. AUTHORIZED REPRESENTATIVE
---	--

ACORD 25 (2010/05) © 1988-2010 ACORD CORPORATION. All rights reserved. The ACORD name and logo are registered marks of ACORD