



Purchasing Division
 2019 Washington Street East
 Post Office Box 50130
 Charleston, WV 25305-0130

State of West Virginia
 Request for Quotation
 01 - Agricultural

Proc Folder: 136612

Doc Description: Addendum 1 - Day Cab Tandem Tractor for Donated Foods

Proc Type: Central Purchase Order

Date Issued	Solicitation Closes	Solicitation No	Version
2016-01-11	2016-01-19 13:30:00	CRFQ 1400 AGR1600000004	2

BID RECEIVING LOCATION

BID CLERK
 DEPARTMENT OF ADMINISTRATION
 PURCHASING DIVISION
 2019 WASHINGTON ST E
 CHARLESTON WV 25305
 US

VENDOR

Vendor Name, Address and Telephone Number:
Walker Machinery
112 Carbide Dr.
Belle, W.V. 25015
304-949-1600

Cecil I. Walker Machinery Co.
 Route 80, East
 P. O. Box 2427
 Charleston, WV 25329

01/19/16 12:19:08
 WV Purchasing Division

FOR INFORMATION CONTACT THE BUYER
 Linda Harper
 (304) 558-0468
 linda.b.harper@wv.gov

Signature X  FEIN # DATE *1-18-16*

All offers subject to all terms and conditions contained in this solicitation

ADDITIONAL INFORMATION:

Addendum 1 - filed to publish the Vendor questions with responses.

No other changes.

The West Virginia Purchasing Division for the Agency, The West Virginia Department of Agriculture is soliciting bids from qualified vendors to establish a "One-Time" contract for the purchase of 2016 or newer Class 8 Day Cab Tandem Tractor per the Specifications, Terms & Conditions and bid requirements as attached.

INVOICE TO		SHIP TO	
PROCUREMENT OFFICER 304-558-2221		AUTHORIZED RECEIVER 304-558-0573	
AGRICULTURE DEPARTMENT OF ADMINISTRATIVE SERVICES		AGRICULTURE DEPARTMENT OF FOOD DISTRIBUTION PROGRAM	
1900 KANAWHA BLVD E		4496 CEDAR LAKES RD	
CHARLESTON	WV25305-0173	RIPLEY	WV 25271
US		US	

Line	Comm Ln Desc	Qty	Unit Issue	Unit Price	Total Price
1	2016 class 8 day cab tandem truck	1.00000	EA		

Comm Code	Manufacturer	Specification	Model #
25102100			

Extended Description :

2016 (or newer) Class 8 Day Cab Tandem Truck

SCHEDULE OF EVENTS

Line	Event	Event Date
1	Question Deadline 5:00 PM	2016-01-05

AGR1600000004	Document Phase Final	Document Description Addendum 1 - Day Cab Tandem Tractor for Donated Foods	Page 3 of 3
----------------------	--------------------------------	---	------------------------------

ADDITIONAL TERMS AND CONDITIONS

See attached document(s) for additional Terms and Conditions

CERTIFICATION AND SIGNATURE PAGE

By signing below, or submitting documentation through wvOASIS, I certify that I have reviewed this Solicitation in its entirety; that I understand the requirements, terms and conditions, and other information contained herein; that this bid, offer or proposal constitutes an offer to the State that cannot be unilaterally withdrawn; that the product or service proposed meets the mandatory requirements contained in the Solicitation for that product or service, unless otherwise stated herein; that the Vendor accepts the terms and conditions contained in the Solicitation, unless otherwise stated herein; that I am submitting this bid, offer or proposal for review and consideration; that I am authorized by the vendor to execute and submit this bid, offer, or proposal, or any documents related thereto on vendor's behalf; that I am authorized to bind the vendor in a contractual relationship; and that to the best of my knowledge, the vendor has properly registered with any State agency that may require registration.

Walker Machinery
(Company)

Gene Miller Sales Rep
(Authorized Signature) (Representative Name, Title)

304-549-8111
(Phone Number) (Fax Number) (Date)

SOLICITATION NUMBER: AGR1600000004

Addendum Number: 1

The purpose of this addendum is to modify the solicitation identified as ("Solicitation") to reflect the change(s) identified and described below.

Applicable Addendum Category:

- | Modify bid opening date and time
- | Modify specifications of product or service being sought
- | Attachment of vendor questions and responses
- | Attachment of pre-bid sign-in sheet
- | Correction of error
- | Other

Description of Modification to Solicitation:

1. To publish the vendor questions with responses.

No other changes.

Additional Documentation: Documentation related to this Addendum (if any) has been included herewith as Attachment A and is specifically incorporated herein by reference.

Terms and Conditions:

1. All provisions of the Solicitation and other addenda not modified herein shall remain in full force and effect.
2. Vendor should acknowledge receipt of all addenda issued for this Solicitation by completing an Addendum Acknowledgment, a copy of which is included herewith. Failure to acknowledge addenda may result in bid disqualification. The addendum acknowledgement should be submitted with the bid to expedite document processing.

**CRFQ AGR1600000004
Tandem Tractor
Vendor Questions**

Q.1. 3.1.1.2 - Our MACK ENGINES are MODELS MP8-445C (445 HP) and MP8-505C (505 HP) They are 14 liter engines. Can they be considered equal to your spec?

A.1. The 455HP we will consider but the 505HP is above the MAX HP.

Q. 2. 3.1.1.21 - Our fuel tank mounts are steel and not stainless steel. Can they be approved for spec?

A.2. Yes

Q. 3. 3.1.1.29 - Our battery box is also steel and not aluminum. Can that be approved for the spec?

A.3. Yes

ADDENDUM ACKNOWLEDGEMENT FORM
SOLICITATION NO.: AGR160000004

Instructions: Please acknowledge receipt of all addenda issued with this solicitation by completing this addendum acknowledgment form. Check the box next to each addendum received and sign below. Failure to acknowledge addenda may result in bid disqualification.

Acknowledgment: I hereby acknowledge receipt of the following addenda and have made the necessary revisions to my proposal, plans and/or specification, etc.

Addendum Numbers Received:

(Check the box next to each addendum received)

- | | |
|--|--|
| <input checked="" type="checkbox"/> Addendum No. 1 | <input type="checkbox"/> Addendum No. 6 |
| <input type="checkbox"/> Addendum No. 2 | <input type="checkbox"/> Addendum No. 7 |
| <input type="checkbox"/> Addendum No. 3 | <input type="checkbox"/> Addendum No. 8 |
| <input type="checkbox"/> Addendum No. 4 | <input type="checkbox"/> Addendum No. 9 |
| <input type="checkbox"/> Addendum No. 5 | <input type="checkbox"/> Addendum No. 10 |

I understand that failure to confirm the receipt of addenda may be cause for rejection of this bid. I further understand that any verbal representation made or assumed to be made during any oral discussion held between Vendor's representatives and any state personnel is not binding. Only the information issued in writing and added to the specifications by an official addendum is binding.

Walker Machinery

Company

Ben Miller

Authorized Signature

1/15/16

Date

NOTE: This addendum acknowledgment should be submitted with the bid to expedite document processing.

Revised 6/8/2012

REQUEST FOR QUOTATION
2016 or Newer Class 8 Day Cab Tandem Tractor

SPECIFICATIONS

1. **PURPOSE AND SCOPE:** The West Virginia Purchasing Division is soliciting bids on behalf of West Virginia Department of Agriculture to establish a contract for the one time purchase of a 2016 or newer Class 8 Day Cab Tandem Tractor.
2. **DEFINITIONS:** The terms listed below shall have the meanings assigned to them below. Additional definitions can be found in section 2 of the General Terms and Conditions.
 - 2.1 **“Contract Item”** means 2016 or newer Class 8 Day Cab Tandem Tractor as more fully described by these specifications.
 - 2.2 **“Pricing Page”** means the pages, contained in wvOASIS or attached as Exhibit A, upon which Vendor should list its proposed price for the Contract Items.
 - 2.3 **“Solicitation”** means the official notice of an opportunity to supply the State with goods or services that is published by the Purchasing Division..
3. **GENERAL REQUIREMENTS:**
 - 3.1 **Mandatory Contract Item Requirements:** Contract Item must meet or exceed the mandatory requirements listed below.
 - 3.1.1 **2016 or newer class 8 Day Cab Tandem Tractor**
 - 3.1.1.1 Wheelbase must accommodate a 48 foot reefer trailer.
 - 3.1.1.2 Engine -- Cummins ISx15 or Detroit DD15 or equal min. hp 450 to max hp 500 ~
 - 3.1.1.3 Engine brake or equal, **No Exhaust Brake** ✓
 - 3.1.1.4 Engine Block heater 1500 watts-min ✓
 - 3.1.1.5 Exhaust single vertical stainless steel from motor with guard. ✓
 - 3.1.1.6 Transmission must be 13 speed or equal. ✓

REQUEST FOR QUOTATION
2016 or Newer Class 8 Day Cab Tandem Tractor

- 3.1.1.7 Cab Interior must have Air conditioner with heat and filter ✓
- 3.1.1.8 Power windows both sides, ✓
- 3.1.1.9 Mirrors—remote controlled with built in convex and heated ✓
min. 10 inch convex mounted on LH & RH front fender or hood
- 3.1.1.10 Radio—AM-FM-CD and blue tooth ✓
- 3.1.1.11 Truck must be Prewired for CB Radio including dual mounted antenna's
- 3.1.1.12 Driver seat high profile air ride or equal ✓
- 3.1.1.13 passenger seat no air ✓
- 3.1.1.14 Sun visor—Interior both sides padded ✓
- 3.1.1.15 Power steering, Tilt & telescopic steering & smallest steering ✓
wheel available for unit
- 3.1.1.16 Truck must have Cruise control ✓
- 3.1.1.17 Anti-sail mud flaps with stainless steel mounts ✓
- 3.1.1.18 Roof mounted air deflector not to exceed 12.5' total truck ✓
height
- 3.1.1.19 Cat walk mounted behind cab, all pigtailed spring mounted on
back of cab with glad hand mount, 12volt pigtail to charge lift
gate on trailer
- 3.1.1.20 Stainless steel front bumper ✓
- 3.1.1.21 Fuel Tanks must be Minimum 100 gal. LH & 100 gal. RH
alum. With stainless steel mounts and straps. ✓

REQUEST FOR QUOTATION
2016 or Newer Class 8 Day Cab Tandem Tractor

- 3.1.1.22 Front Axle must be Minimum 12,000 # cap. Step back for tight turning springs: Flat leaf or taper leaf. ✓
- 3.1.1.23 Rear Axle must be Minimum 40,000# cap. Tandem with driver controlled differential lock suspension: air ride with inside cab mount dump valve. Geared to maintain 70 MPH at 300-RPM below governor on engine. ✓
- 3.1.1.24 Tires all season on rear (no low profile) 16 ply minimum. ✓
- 3.1.1.25 Wheels: Aluminum ✓
- 3.1.1.26 Breaks must be "S" cam brakes with auto adjusters ✓
- 3.1.1.27 Must have Air dryer: ✓
- 3.1.1.28 Electrical must be 12volt system ✓
- 3.1.1.29 Alum. Battery box & cover ✓
- 3.1.1.30 Fifth Wheel must be Fontaine no-slack II, C7000 series with air slide 24 inch travel or equal
- 3.1.1.31 Warranty must be 3 year bumper to bumper

4. CONTRACT AWARD:

4.1 Contract Award: The Contract is intended to provide Agencies with a purchase price for the Contract Items. The Contract shall be awarded to the Vendor that provides the Contract Items meeting the required specifications for the lowest overall total cost as shown on the Pricing Pages.

4.2 Pricing Page: Vendor should complete the Pricing Page by listing the equipment as one cost. Vendor should complete the Pricing Page in full as failure to complete the Pricing Page in its entirety may result in Vendor's bid being disqualified.

Vendor should type or electronically enter the information into the Pricing Page to prevent errors in the evaluation.

REQUEST FOR QUOTATION
2016 or Newer Class 8 Day Cab Tandem Tractor

5. PAYMENT:

5.1 Payment: Vendor shall accept payment in accordance with the payment procedures of the State of West Virginia.

6. DELIVERY AND RETURN:

6.1 Shipment and Delivery: Vendor shall ship the Contract Items immediately after being awarded this Contract and receiving a purchase order. Vendor shall deliver the Contract Items within 180 days working days after receiving a purchase order. Contract Items must be delivered to Agency at 4496 Cedar Lakes Road, Ripley, WV 25271.

6.2 Late Delivery: The Agency placing the order under this Contract must be notified in writing if the shipment of the Contract Items will be delayed for any reason. Any delay in delivery that could cause harm to an Agency will be grounds for cancellation of the Contract, and/or obtaining the Contract Items from a third party.

Any Agency seeking to obtain the Contract Items from a third party under this provision must first obtain approval of the Purchasing Division.

6.3 Delivery Payment/Risk of Loss: Vendor shall deliver the Contract Items F.O.B. destination to the Agency's location.

6.4 Return of Unacceptable Items: If the Agency deems the Contract Items to be unacceptable, the Contract Items shall be returned to Vendor at Vendor's expense and with no restocking charge. Vendor shall either make arrangements for the return within five (5) days of being notified that items are unacceptable, or permit the Agency to arrange for the return and reimburse Agency for delivery expenses. If the original packaging cannot be utilized for the return, Vendor will supply the Agency with appropriate return packaging upon request. All returns of unacceptable items shall be F.O.B. the Agency's location. The returned product shall either be replaced, or the Agency shall receive a full credit or refund for the purchase price, at the Agency's discretion.

6.5 Return Due to Agency Error: Items ordered in error by the Agency will be returned for credit within 30 days of receipt, F.O.B. Vendor's location. Vendor shall not charge a restocking fee if returned products are in a resalable condition. Items shall be deemed to be in a resalable condition if they are unused and in the original packaging. Any restocking fee for items not in a resalable condition shall

REQUEST FOR QUOTATION
2016 or Newer Class 8 Day Cab Tandem Tractor

be the lower of the Vendor's customary restocking fee or 5% of the total invoiced value of the returned items.

7 VENDOR DEFAULT:

7.1 The following shall be considered a vendor default under this Contract.

- 7.1.1** Failure to provide Contract Items in accordance with the requirements contained herein.
- 7.1.2** Failure to comply with other specifications and requirements contained herein.
- 7.1.3** Failure to comply with any laws, rules, and ordinances applicable to the Contract Services provided under this Contract.
- 7.1.4** Failure to remedy deficient performance upon request.

7.2 The following remedies shall be available to Agency upon default.

- 7.2.1** Immediate cancellation of the Contract.
- 7.2.2** Immediate cancellation of one or more release orders issued under this Contract.
- 7.2.3** Any other remedies available in law or equity.



CT660S SBA 6x4

Sales Proposal For:

WV Dept of Agriculture

Presented By:

CECIL I. WALKER MCHY CO



January 15, 2016

Prepared For:
WV Dept of Agriculture
Reference ID: N/A

Presented By:
CECIL I. WALKER MCHY CO
Charlie Evans
112 Carbide Drive
BELLE WV 25015 - 2427
(304)949-1600

We are pleased to have the opportunity to offer the following proposal for the application you requested.

Please See Attached Programs:

Walker Machinery is offering a Service Maintenance Agreement that provides the customer with \$1500 in filters and SOS bottles (part numbers attached to the proposal). To obtain this program the customer must agree to service contract for 24 months with dealer. The details and cost for this agreement are also attached. Also, customer must keep Product Link active on unit during this period.

Filters and SOS bottles can be supplied to customer at time of delivery of unit or as service needs are met.

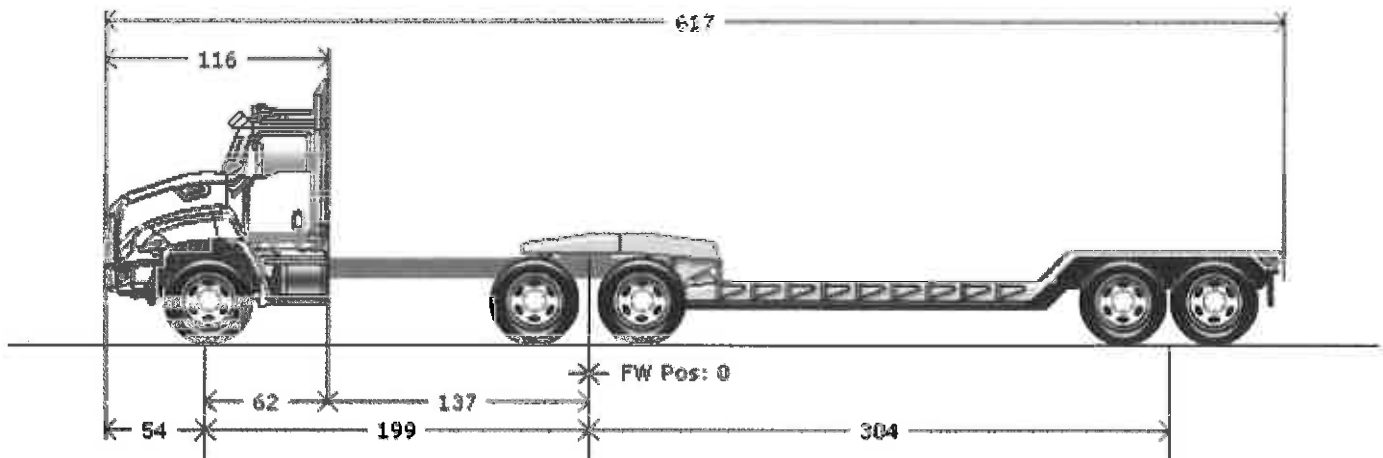

Model Profile
2017 CT660S SBA 6x4 (CF7AA)

APPLICATION:	Heavy Hauler Tractor
MISSION:	Requested GCWR: 80000. Calc. GVWR: 53200 Calc. Start / Grade Ability: 18.61% / 1.81% @ 55 MPH Calc. Geared Speed: 94.6 MPH
DIMENSION:	Wheelbase: 199.00, CA: 137.00, Axle to Frame: 65.00
ENGINE, DIESEL:	{CT 13} EPA 2010, SCR, 475 HP @ 1700 RPM, 1700 lb-ft Torque @ 1000 RPM, 2100 RPM Governed Speed, 475 Peak HP (Max)
TRANSMISSION, MANUAL:	{Fuller RTLO(F)-16913A} 13-Speed Manual; With Double Overdrive, With Air Shift and Internal Lube Oil Pump
CLUTCH:	{Eaton Fuller Easy-Pedal Advantage} Manual Adjust, Two-Plate, Cast Angle Spring; Ceramic, 15.5" Diameter, 7-Spring Damper, Mechanical Pull-Type Control, 1700 lb-ft Torque Capacity
AXLE, FRONT NON-DRIVING:	{Meritor MFS-13-143A} Wide Track, I-Beam Type, 13,200-lb Capacity
AXLE, REAR, TANDEM:	{Meritor MT-40-14X-4DER-P} Single Reduction, 0.433"(11mm) Wall Housing Thickness, 40,000-lb Capacity, R Wheel Ends, Driver Controlled Locking Differential in Rear-Rear Axle, Lube Oil Pump Gear Ratio: 3.90
CAB:	Conventional
TIRE, FRONT:	(2) 11R24.5 ECO PLUS HS3 (CONTINENTAL) 472 rev/mile, load range H, 16 ply
TIRE, REAR:	(8) 11R24.5 HDR2 (CONTINENTAL) 468 rev/mile, load range H, 16 ply



January 15, 2016

SUSPENSION, REAR, AIR, TANDEM: {Hendrickson HAS-402-55} 55" Axle Spacing; 40,000-lb Capacity, 9.5" Ride Height, With Shock Absorbers Mounted in Standard Location

PAINT: Cab schematic 100KT
Location 1: 9256, White (Prem)
Chassis schematic N/A



Vehicle Specifications

January 15, 2016

2017 CT660S SBA 6x4 (CF7AA)

<u>Code</u>	<u>Description</u>
CF7AA00	Base Chassis, Model CT660S SBA 6x4 with 199.00 Wheelbase, 137.00 CA, and 65.00 Axle to Frame.
1570	TOW HOOK, FRONT (2) Frame Mounted
1616	FRAME RAILS WITH TAPERED REAR
1832	DECK PLATE Aluminum; Two Sections 15" Wide
1CDH	FRAME RAILS Heat Treated Alloy Steel (120,000 PSI Yield); 12.250" x 3.380" x 0.375" (304.8mm x 85.6mm x 9.5mm); 543.0" (13793mm) Maximum OAL
1LBC	BUMPER, FRONT Multi-piece Stainless Steel <u>Includes</u> : FOG LIGHT OPENING (2) and with Rectangular Hole for Step
1WVS	WHEELBASE RANGE 183" (465cm) Through and Including 228" (580cm)
2ASG	AXLE, FRONT NON-DRIVING {Meritor MFS-13-143A} Wide Track, I-Beam Type, 13,200-lb Capacity
3AGD	SUSPENSION, FRONT, SPRING Parabolic, Taper Leaf; 13,200-lb Capacity; With Shock Absorbers
4092	BRAKE SYSTEM, AIR Dual System for Tractor Applications <u>Includes</u> : BRAKE LINES Color and Size Coded Nylon : DRAIN VALVE Twist-Type : GAUGE, AIR PRESSURE (2) Air 1 and Air 2 Gauges; Located in Instrument Cluster : GLAD HANDS (2) One for Service and One for Emergency; Trailer Hoses from Cab : HAND CONTROL VALVE, AIR Mounted on Steering Column : HOSE TENDER Back of Cab Mounted : PARKING BRAKE CONTROL Yellow and Red Knobs, Located on Instrument Panel : PARKING BRAKE VALVE Combination Valve for Tractor and Trailer : QUICK RELEASE VALVE Bendix On Rear Axle for Spring Brake Release: 1 for Forward Rear Axle : SLACK ADJUSTERS, FRONT Automatic : SLACK ADJUSTERS, REAR Automatic : SWITCH, AUXILIARY Interrupter for Cab and Trailer Clearance/Marker Lights (Blinks Lights with Headlight Switch in "ON" Position); Instrument Panel Mounted : TRACTOR PROTECTION VALVE : TRAILER HOSES AND CABLES 15' Coiled Lighting Cable with 7-Way Connector and with 15' Coiled Nylon Brake Hose
	<u>Notes</u> : The following features should be considered when calculating Rear GAWR: Rear Axles; Rear Suspension; Brake System; Brakes, Rear Air Cam; Brake Shoes, Rear; Special Rating, GAWR; Wheels; Tires.
4196	BRAKES, FRONT, AIR CAM 16.5" x 5", Includes 24 SqIn Long Stroke Brake Chambers
4692	HOSE TENDER Flexible Pogo Stick Type
4732	DRAIN VALVE {Berg} Manual; With Pull Chain, for Air Tank <u>Includes</u> : DRAIN VALVE Mounted in Wet Tank
4AAU	BRAKE CHAMBERS, ADDITIONAL (2) {Bendix} Spring Brake Type; 30/30 SqIn
4AZA	AIR BRAKE ABS {Bendix AntiLock Brake System} Full Vehicle Wheel Control System (4-Channel)
4EBS	AIR DRYER {Bendix AD-9} With Heater <u>Includes</u> : AIR DRYER LOCATION Inside Left Rail, Back of Cab
4EXU	BRAKE CHAMBERS, REAR AXLE {Bendix EverSure} 30/30 Spring Brake



Vehicle Specifications

January 15, 2016

2017 CT660S SBA 6x4 (CF7AA)

<u>Code</u>	<u>Description</u>
4EXV	BRAKE CHAMBERS, FRONT AXLE {Bendix} 24 SqIn
4NDB	BRAKES, REAR, AIR CAM S-Cam; 16.5" x 7.0"; Includes 30/30 Sq.In. Long Stroke Brake Chamber and Spring Actuated Parking Brake
4SPM	AIR COMPRESSOR {Bendix BA-921 Head Unload} 15.9 CFM Capacity, Single Cylinder
5710	STEERING COLUMN Tilting and Telescoping
5PSA	STEERING GEAR {Sheppard M-100} Power
5WBH	STEERING WHEEL {Caterpillar} 2-Spoke, 18" Diam., Dark Neutral, Leather Wrapped
7BJU	EXHAUST SYSTEM Switchback Horizontal Aftertreatment Device, Frame Mounted Right Side Under Cab; Includes Single Vertical Tail Pipe & Guard, Right Side, Cab Mounted
7SDD	ENGINE COMPRESSION BRAKE {Jacobs} for CT 11 & CT 13 Engines, With Selector Switch and On/Off Switch
7WBA	TAIL PIPE (1) Turnback Type, Bright, for Single Exhaust
7WBS	MUFFLER/TAIL PIPE GUARD (1) Bright Stainless Steel
8000	ELECTRICAL SYSTEM 12-Volt, Standard Equipment
	<u>Includes</u>
	: BATTERY BOX Aluminum
	: CIGAR LIGHTER Includes Ash Cup, Center Console Mounted
	: FUSES, ELECTRICAL SAE Blade-Type
	: HAZARD SWITCH Integral with Turn Signal Switch
	: HEADLIGHT DIMMER SWITCH Integral with Turn Signal Lever
	: HEADLIGHTS (2) Composite with Halogen Projector Beam
	: HORN, AIR Single, Chrome
	: HORN, ELECTRIC Single
	: PARKING LIGHT Integral with Front Turn Signal and Rear Tail Light
	: READING LIGHT, CAB (2) with Individual Switches; One Above Each Door
	: STARTER SWITCH Electric, Key Operated
	: STOP, TURN, TAIL & B/U LIGHTS Dual, Rear, Combination with Reflector
	: TURN SIGNAL FLASHER
	: TURN SIGNAL SWITCH Manual Cancelling with Lane Change Feature
	: TURN SIGNALS, FRONT Includes Integral Reflectors and Side Marker Lights; Fender Mounted
	: WINDSHIELD WIPER SWITCH 2-Speed with Wash and Intermittent Feature, Steering Column Mounted
	: WINDSHIELD WIPERS Single Motor, Electric, Cowl Mounted
	: WIRING, CHASSIS Color Coded and Continuously Numbered
8653	HORN, AIR Single, Located Under Cab
8718	POWER SOURCE Cigar Type Receptacle without Plug and Cord
8GGN	ALTERNATOR {Bosch LH160} Brush Type, 12 Volt 160 Amp. Capacity, Pad Mount
8MMJ	BATTERY SYSTEM {Caterpillar} (3) 12 Volt 2130CCA Total
8RMB	RADIO AM/FM/CD/WB/Clock/Bluetooth/USB Input/3MM Auxiliary Input, MP3, Apple Device Play & Control, Bluetooth for Phone & Music, with Multiple Speakers
8RMG	ANTENNA BASE (2) Single Function, (1) for CB and (1) for Entertainment Radio, Without Splitter, Separate Lead-Ins, With CB Antenna Mounted on Left Mirror and AM/FM Antenna Mounted on Right Mirror
8VUH	BATTERY BOX COVER Polished Aluminum
8WCK	POWER SOURCE, TERMINAL TYPE 2-Post
8WDG	BACK-UP ALARM {Preco 1059} Electronic; Solid State, Dual Function, 112 dBA



Vehicle Specifications

January 15, 2016

2017 CT660S SBA 6x4 (CF7AA)

<u>Code</u>	<u>Description</u>
8WEZ	TURN SIGNAL SWITCH Self-Canceling
8WJN	BATTERY BOX Aluminum With Plastic Cover, 30" Wide, 2, 3 or 4 Battery Capacity, Mounted Left Side Under Cab
8WNH	RUNNING LIGHT (2) Daytime
8WVR	FOG LIGHTS (2) Clear, Round, Halogen
8WVG	STARTING MOTOR {Mitsubishi Electric Automotive America 105P} 12-Volt, with Soft-Start
9505	QUARTER FENDERS for Rear Wheels, Mirror-Finished Stainless Steel, Frame Mounted
9ASE	FRONT END Tilting Composite
	<u>Includes</u> : GRILLE SURROUND Brushed Stainless Steel
9HAN	INSULATION, UNDER HOOD for Sound Abatement
9HBN	INSULATION, SPLASH PANELS for Sound Abatement
10060	PAINT SCHEMATIC, PT-1 Single Color, Design 100
10761	PAINT TYPE Base Coat/Clear Coat, 1-2 Tone
10769	PAINT CLASS Premium Color
10HJA	FIFTH WHEEL, AIR SLIDE {Fontaine SL7LWB675024} 24" Slide, Cast Top Plate, 6.75" Above Top of Frame; Left Side Release
10UAD	VEHICLE REGISTRATION IDENTITY ID for 49 States, Excluding California
10WLX	MUD FLAPS, REAR Black Rubber, Anti-Sail "CAT" Silver Logo; Less Holders
10WPU	MUD FLAP HOLDER Spring Loaded, Bright Finish; With 45-Degree End, With Red and White Reflective Tape; Less Flaps
11MGZ	CLUTCH {Eaton Fuller Easy-Pedal Advantage} Manual Adjust, Two-Plate, Cast Angle Spring; Ceramic, 15.5" Diameter, 7-Spring Damper, Mechanical Pull-Type Control, 1700 lb-ft Torque Capacity
	<u>Includes</u> : CLUTCH RELEASE BEARING Greasable
11WAE	GREASE FITTINGS Remote; for Clutch Cross Shaft
11WAG	CLUTCH BRAKE Two-Piece
12864	BLOCK HEATER, ENGINE {Phillips} 120 Volt/1500 Watt
12KXS	ENGINE, DIESEL {CT 13} EPA 2010, SCR, 475 HP @ 1700 RPM, 1700 lb-ft Torque @ 1000 RPM, 2100 RPM Governed Speed, 475 Peak HP (Max)
12THT	FAN DRIVE {Horton Drivemaster} Direct Drive Type, Two Speed With Residual Torque Device for Disengaged Fan Speed
12UNV	FEDERAL EMISSIONS {Caterpillar CT13} EPA, OBD and GHG Certified for Calendar Year 2016
12VBT	AIR CLEANER Single Element, Heavy Duty
12WCX	HOSE CLAMPS, RADIATOR HOSES {Gates} Shrink Band Type
12WEG	COLD STARTING EQUIPMENT Automatic; With Engine ECM Control
12WEV	ELECTRONIC DATA LINK Translator Control for Caterpillar; Translation Between J1939 500K and J1939 250K Broadcast Messages
12WTA	FAN DRIVE SPECIAL EFFECTS Fan Cooling Ring with Fan Shroud Effects, Engine Mounted



Vehicle Specifications

January 15, 2016

2017 CT660S SBA 6x4 (CF7AA)

<u>Code</u>	<u>Description</u>
12WZJ	EMISSION COMPLIANCE Low NOx Idle Engine, Complies with California Clean Air Regulations; Includes "Certified Clean Idle" Decal located on Driver Door
12XAV	RADIATOR Aluminum; Welded, Front to Back Down Flow System, 1429 SqIn, 740 SqIn CAC, 1099 SqIn 3 Core LTR
13GKJ	TRANSMISSION, MANUAL {Fuller RTLO(F)-16913A} 13-Speed Manual; With Double Overdrive, With Air Shift and Internal Lube Oil Pump
	<u>Includes</u> : CLUTCH BRAKE Torque Limiting : FILL PLUG, MAGNETIC
13WGJ	OIL COOLER,MANUAL TRANSMISSION Water to Oil Type Included in Radiator End Tank (REQUIRES TRANSMISSION LUBE PUMP)
14899	SUSPENSION AIR CONTROL VALVE Pressure Release Control In Cab
14GVJ	AXLE, REAR, TANDEM {Meritor MT-40-14X-4DER-P} Single Reduction, 0.433"(11mm) Wall Housing Thickness, 40,000-lb Capacity, R Wheel Ends, Driver Controlled Locking Differential in Rear-Rear Axle, Lube Oil Pump . Gear Ratio: 3.90
	<u>Includes</u> : POWER DIVIDER LOCK Air Operated, Cab Control with Indicator Light in Cluster : REAR AXLE DRAIN PLUG (2) Magnetic, For Tandem Rear Axle
14UKZ	SUSPENSION, REAR, AIR, TANDEM {Hendrickson HAS-402-55} 55" Axle Spacing; 40,000-lb Capacity, 9.5" Ride Height, With Shock Absorbers Mounted in Standard Location
15960	FUEL TANK STRAPS Bright Finish Stainless Steel, for Dual Fuel Tanks
15DXE	FUEL TANK (2) Non-Polished Aluminum, 24" Diam., 100 U.S. Gal., 378L Capacity; Total Capacity 200 U.S. Gal., 757L; with Dual Supply & Return Lines and Less Equalizer Line, Mounted Left & Right, Back of Cab
15DYR	DEF TANK 9.5 U.S. Gal. 36.0L Capacity, Frame Mounted Outside Left Rail, Back of Cab
15LKU	FUEL/WATER SEPARATOR {Racor} Fuel Pre-Filter and Filter Base, Includes Water-In-Fuel Sensor
16031	CAB Conventional
	<u>Includes</u> : COAT HOOK, CAB Located on Rear Wall, Behind Passenger Seat : CONSOLE, CENTER Plastic, Driver Convenience with a Cup and Change Holder, Ash Tray and Lower Storage Area : DOME LIGHT, CAB (2) Driver and Passenger Dome Lights with Individual Switches, in Headliner : DOOR CHECK STRAP (2) One Each Door : GLASS, ALL WINDOWS Tinted : GRAB HANDLE, CAB INTERIOR (1) "A" Pillar Mounted, Passenger Side : GRAB HANDLE, EXTERIOR (2) Mounted Behind Driver and Passenger Doors : INTERIOR SHEET METAL Upper Door (Above Window Ledge) Painted Exterior Color : SKIN Riveted : STEP (4) Two Steps Per Door
16ABZ	MISMATCH SEAT ID Seat Deviation; Dealer/Customer to Accept Mismatch Driver or Passenger Seat
16HBA	GAUGE CLUSTER English With English Electronic Speedometer
16HLB	GAUGE, AIR PRESSURE for Pressure in Rear Air Suspension; Mounted In Instrument Panel
16JPD	SEAT, DRIVER {National 2000 Model 195} Air Suspension, High Back, Vinyl Boxing With Cloth Facing, 2 Arm Rests, Isolator, Adjuster, 3 Chamber Lumbar, 6 Position Front Cushion Adjust, 3 Position Rear Cushion Adj, 2-15 Degree Back Angle Adjust, Vinyl Suspension Cover
16RAC	SEAT, PASSENGER {National 2000 Model 292} Non Suspension, Intermediate Back, All Vinyl, 11 Degree Back Angle Adjustment



Vehicle Specifications

January 15, 2016

2017 CT660S SBA 6x4 (CF7AA)

<u>Code</u>	<u>Description</u>
16SEY	MIRROR, CONVEX, HOOD MOUNTED {Lang Mekra} Right and Left Sides; 7.44" Sq., Black
16SKU	MIRRORS (2) {Lang Mekra} Aero; Rectangular, Power Both Sides, Thermostatically Controlled Heated Heads, Amber Lens Clearance Light LED, Black Painted Finish Heads, Brackets & Arms, Breakaway Type, 7.09" x 15.75" & Integral Convex Both Sides, 102" Inside Spacing
16UZJ	STORAGE, REAR WALL ; Storage Pocket, Located on Back Wall Between Driver and Passenger Seats
16VRT	HEATER, ENHANCED CIRCULATION {Bergstrom} Control, for Extreme Cold Weather Climates
16VTH	CAB INTERIOR TRIM Premium Level; for Caterpillar, Day Cab
	<u>Includes</u>
	: "A" PILLAR COVER Molded Plastic
	: CAB INTERIOR TRIM PANELS Vinyl
	: CONSOLE, OVERHEAD Molded Plastic with Three Storage Pockets; One with Strap for CB Radio Mounting; Two with Netting, Courtesy Lights with Switches
	: COURTESY LIGHT (2) Driver and Passenger Door Mounted
	: DOOR TRIM PANELS Vinyl Upper with Power Locks and Windows, Upper and Lower Grab Handles, Both Sides
	: FLOOR COVERING Rubber, Black
	: HEADLINER Soft Padded Vinyl
	: HEATER BOX Metal, Painted Black
	: INSTRUMENT PANEL TRIM Vinyl
	: MIRROR, CONVEX, LOOK DOWN Black Finish; 6" x 10-1/4"; Located on Passenger Side
	: STORAGE POCKET, DOOR (2) Driver and Passenger Door
	: SUN VISOR (2) Vinyl with Molded Toll Ticket Retainer
16VZA	WINDOW, REAR 52.25" Wide
16WAK	WINDOW, POWER (2) in Left and Right Doors
16WBX	SEAT BELT All Belting Must Be Orange
16WJG	CAB DOOR LOCKS Power
16WKB	AIR CONDITIONER {International Blend-Air} With Integral Heater & Defroster
16WKR	WINDSHIELD Single Piece
16WLD	CAB REAR SUSPENSION Dual Frame Mounted Cab Rear Air Suspension; Includes Special Crossmember Assembly
16XWD	SUNSHADE, EXTERIOR Aerodynamic, Painted Roof Color; Includes Integral Clearance/Marker Lights
16ZDV	GRAB HANDLE Exterior; Towel Bar Type In Lieu Of Non-Bright Grab Handles; for use with Cab/Frame or Cab/Frame/Sleeper Non-Bright Access, Without Chassis Skirts
16ZGV	ACCESS, FRAME Non-Bright, Step Mounted Left Side, With One Deck Plate and Grab Handle
27DMJ	WHEELS, FRONT DISC; 24.5" Non-Polished Aluminum, 10-Stud (285.75MM BC) Hub Piloted, Flanged Nut, Metric Mount, 8.25 DC Rims; With Steel Hubs
28DMJ	WHEELS, REAR DUAL DISC; 24.5" Non-Polished Aluminum, 10-Stud (285.75MM BC) Hub Piloted, Flanged Nut, Metric Mount, 8.25 DC Rims; With Steel Hubs.
29WAP	WHEEL GUARDS, FRONT {Accuride} for Metric Hub Piloted Wheels with Flanged Mounting Nuts Mounted Between Hub and Wheel
7384225423	(8) TIRE, REAR 11R24.5 HDR2 (CONTINENTAL) 468 rev/mile, load range H, 16 ply
7384225429	(2) TIRE, FRONT 11R24.5 ECO PLUS HS3 (CONTINENTAL) 472 rev/mile, load range H, 16 ply
810000	FIFTH WHEEL LOCATION On Rear Axle Centerline



Vehicle Specifications

January 15, 2016

2017 CT660S SBA 6x4 (CF7AA)

Code

1

Description

Factory install Airodyne roof deflector

PO CAM000827

Truck Specialty Centers

DOT Fire Ext, Safety Trangles

Fuel

Install Chrome Wheel and Lug Nut Covers



Financial Summary

January 15, 2016

**2017 CT660S SBA 6x4 (CF7AA)
(US DOLLAR)**

<u>Description</u>		<u>Price</u>
Factory List Prices:		
Product Items	\$173,038.49	
Service Items	\$0.00	
Total Factory List Price Including Options:		\$173,038.49
Total Goods Purchased:		\$779.84
Freight	\$2,200.00	
Total Freight:		\$2,200.00
Total Factory List Price Including Freight:		\$176,018.33
Less Customer Allowance:		(\$60,189.77)
Total Vehicle Price:		\$115,828.56
Total Body/Allied Equipment:		\$4,303.00
Total Warranty:		\$7,500.00
Total Sale Price:		\$127,631.56
Total Per Vehicle Sales Price:		\$127,631.56
Total Net Sales Excluding Taxes:		\$127,631.56
Doc Fee	\$500.00	
Total Taxes:		\$500.00
Net Sales Price:		\$128,131.56

In accordance with our discussion, we are pleased to submit the following confirmation of our verbal quote. We propose to furnish this equipment at the attached quoted price.

Thank you for the opportunity of quoting this project. Our Dealership remains at your disposal for any additional information or assistance that you may require.

Approved by Seller:

Accepted by Purchaser:

Official Title and Date

Authorized Signature

Firm or Business Name

Authorized Signature and Date

This proposal is not binding upon the seller without Seller's Authorized Signature

Official Title and Date

No Reliance on Tax Information. Neither Caterpillar nor its suppliers are responsible for verifying the correctness of all tax computation methods and data. The retailer or other user should perform this verification.



Cat CT660 Preventive Maintenance Agreement

Option 1

Price Protection is guaranteed for twelve (24) months from the date of this agreement. No fluids and no labor are included in the CAT Maintenance Plan. The Plan does provide filters for 6 oil change intervals, Cat Dealer will perform the initial Preventative Maintenance Service intervals PM1 - PM3 of the Cat CT660. This service will include filters (see below), SOS samples needed to perform the preventative maintenance. Cat Dealer will also perform an annual basic inspection.

The Preventative Maintenance Service shall consist of visual inspections, operational checks, adjustments, lubrication, fluid analysis and scheduled filter and oil changes as listed in the operation maintenance manual. The scope of the work will depend on mileage, hours, or length of service.

Cat Dealer will perform the preventive maintenance service at one of our Cat truck service centers Monday through Friday during regular working hours. If Saturday service or after hours service is desired and approved the customer will be responsible for the labor differential. ****Option 1* does not include fluids or labor to perform the needed service and inspections.**

Option 2

We have elected not to participate in Cat's CT660 Preventative Maintenance Plan. We would accept applicable filters and oil sample kits as an alternative option provided by Cat Dealer.

****Option 2** does not include any fluids or labor to perform the needed initial inspection.**

The recommended filters included at the service intervals are;

PM 1. Transmission filter.

PM 2. Engine Oil Filter, Engine SOS sample

PM 3. Engine Oil Filter, Primary Fuel Filter, Secondary Fuel Filter, Air Dryer Desiccant, Transmission SOS sample, Rear Axles SOS sample, Engine SOS sample. Coolant SOS sample

Product Link Activated: Y/N :

Exceptions:

No party to this agreement shall be held responsible for delays or failure in performance resulting from an act beyond reasonable control. Such acts include but are not limited to the following:

Terms of Agreement:

This agreement will expire after **24 months**

The undersigned acknowledges that the responsibilities of Cat Dealer are limited to the servicing of the equipment as outlined herein and does not guarantee the detection or replacement of worn out, defective, or malfunctioning parts. In no event shall Cat Dealer be liable for any direct, indirect, special, incidental, or consequential damages, such as, but not limited to, loss of anticipated profits or other economic loss in connection with, or arising from the furnishing, functioning, or use of any items of equipment or services provided for in this agreement.

Customer Name: _____ Customer # _____ Serial # _____

Customer Signature

By _____ Date _____

Cat Dealer

By _____

WV Department of Agriculture Maintenance Plan Agreement 1a

Truck Serial Number(s):

Customer Name:

Choose Options Here

NOTE: Part numbers & prices are subject to change

#1 Parts

Part Required	Total Required Quantity	Sample Part Description	Sample Part Number
Transmission Oil Filter	3	CX31 cartridge filter element (short)	249-2329
Engine Air filter	4	Air filter element	390-3433
Engine Oil Filter	8	Engine oil filter	472-5753
Primary Fuel Filter	4	Primary fuel filter element (Racor)	430-8929
Secondary fuel filter	4	Secondary fuel filter	376-2578

#2 SOS

SOS Required	Total Required Samples
Engine	8
Cooling System	4
Rear Axle Oil	8
Transmission Oil	1
Power Steering	4

#3 Annual Inspection

Inspection Required	Total Required Hours
1 hour comprehensive visual truck inspection	4

DOT or Cat Truck TA-1 or Dealer Developed

#4 Written CSA Agreement

#5 Product Link Activated

Walker Engine Power



Cecil I. Walker Machinery Company

112 Carbide Drive, Belle, WV 25015

Phone (304) 949-1600 or toll free 1-800-642-8203

Fax (304) 949-7380

Maintenance Plan Service Agreement

ACCT. NAME	WV Dept. of Agriculture		ACCT. #
ADDRESS			
CITY	STATE	OH	ZIP CODE
EST. REQ. BY	TITLE		
MFGR.			
EQUIPPED WITH			
INSPECTOR	Bruce Miller	BRANCH 7	DATE: 1/15/2016

Customer Contact _____

Phone Number _____

REPAIR DESCRIPTION AND LABOR COST	\$ LABOR	\$FLUID	TOTAL
<i>Initial Transmission Filter Change (200hr)</i>			
Transmission filter, transmission fluid SOS, 200 hour filter replacement.	\$105.00		\$105.00
<i>Oil, Air, Fuel</i>			
Oil filter, oil, grease chassis, Change engine oil and filters(oil,fuel,and air) grease chassis. Check all fluid levels. Fluid pricing will be at market price for that time period and not part of this fee. Any SOS required will be completed at this time.	\$210.00	\$178.00	\$388.00
<i>Transmisison Service</i>			
Transmission filter, transmission fluid, SOS 500 hours or 6 months filter and fluid replacement 7 gal transmission fluid Fluid prices to change.	\$105.00	\$334.32	\$439.32
<i>Oil change only - filter included</i>	\$157.50	\$178.00	\$335.50
Customer will keep Product Link Active during the time this Agreement is Active. First threee years will be at no charge. Any subscription renewals will be at current market price			

Customer Signature: _____

Date: _____

WEP Representative: _____

Date: _____

Exhibit A - Pricing Page
 CRFQ AGR1600000004

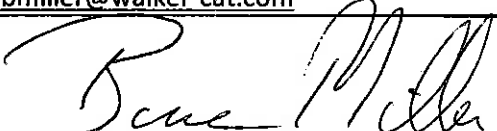
Item No.	Description	Model No/Brand Name	QTY	Unit Price	Extended Amount
1	2016 Class 8 Day Cab Tandem Tractor	CAT CT660S SBA 6x4	1	\$128,131.56	\$128,131.56
Failure to use this form may result in disqualification			GRAND TOTAL (Includes		
Bidder / Vendor Information					
Name:	Walker Machinery				
Address:	112 Carbide Dr				
	Belle, WV 25015				
Phone:	304-549-8111				
Email					
Address:	bmiller@walker-cat.com				
Authorized Signature:					

State of West Virginia

VENDOR PREFERENCE CERTIFICATE

Certification and application is hereby made for Preference in accordance with **West Virginia Code, §5A-3-37**. (Does not apply to construction contracts). **West Virginia Code, §5A-3-37**, provides an opportunity for qualifying vendors to request (at the time of bid) preference for their residency status. Such preference is an evaluation method only and will be applied only to the cost bid in accordance with the **West Virginia Code**. This certificate for application is to be used to request such preference. The Purchasing Division will make the determination of the Vendor Preference, if applicable.

1. **Application is made for 2.5% vendor preference for the reason checked:**
 Bidder is an individual resident vendor and has resided continuously in West Virginia for four (4) years immediately preceding the date of this certification; **or**,
 Bidder is a partnership, association or corporation resident vendor and has maintained its headquarters or principal place of business continuously in West Virginia for four (4) years immediately preceding the date of this certification; or 80% of the ownership interest of Bidder is held by another individual, partnership, association or corporation resident vendor who has maintained its headquarters or principal place of business continuously in West Virginia for four (4) years immediately preceding the date of this certification; **or**,
 Bidder is a nonresident vendor which has an affiliate or subsidiary which employs a minimum of one hundred state residents and which has maintained its headquarters or principal place of business within West Virginia continuously for the four (4) years immediately preceding the date of this certification; **or**,
2. **Application is made for 2.5% vendor preference for the reason checked:**
 Bidder is a resident vendor who certifies that, during the life of the contract, on average at least 75% of the employees working on the project being bid are residents of West Virginia who have resided in the state continuously for the two years immediately preceding submission of this bid; **or**,
3. **Application is made for 2.5% vendor preference for the reason checked:**
 Bidder is a nonresident vendor employing a minimum of one hundred state residents or is a nonresident vendor with an affiliate or subsidiary which maintains its headquarters or principal place of business within West Virginia employing a minimum of one hundred state residents who certifies that, during the life of the contract, on average at least 75% of the employees or Bidder's affiliate's or subsidiary's employees are residents of West Virginia who have resided in the state continuously for the two years immediately preceding submission of this bid; **or**,
4. **Application is made for 5% vendor preference for the reason checked:**
 Bidder meets either the requirement of both subdivisions (1) and (2) or subdivision (1) and (3) as stated above; **or**,
5. **Application is made for 3.5% vendor preference who is a veteran for the reason checked:**
 Bidder is an individual resident vendor who is a veteran of the United States armed forces, the reserves or the National Guard and has resided in West Virginia continuously for the four years immediately preceding the date on which the bid is submitted; **or**,
6. **Application is made for 3.5% vendor preference who is a veteran for the reason checked:**
 Bidder is a resident vendor who is a veteran of the United States armed forces, the reserves or the National Guard, if, for purposes of producing or distributing the commodities or completing the project which is the subject of the vendor's bid and continuously over the entire term of the project, on average at least seventy-five percent of the vendor's employees are residents of West Virginia who have resided in the state continuously for the two immediately preceding years.
7. **Application is made for preference as a non-resident small, women- and minority-owned business, in accordance with West Virginia Code §5A-3-59 and West Virginia Code of State Rules.**
 Bidder has been or expects to be approved prior to contract award by the Purchasing Division as a certified small, women- and minority-owned business.

Bidder understands if the Secretary of Revenue determines that a Bidder receiving preference has failed to continue to meet the requirements for such preference, the Secretary may order the Director of Purchasing to: (a) reject the bid; or (b) assess a penalty against such Bidder in an amount not to exceed 5% of the bid amount and that such penalty will be paid to the contracting agency or deducted from any unpaid balance on the contract or purchase order.

By submission of this certificate, Bidder agrees to disclose any reasonably requested information to the Purchasing Division and authorizes the Department of Revenue to disclose to the Director of Purchasing appropriate information verifying that Bidder has paid the required business taxes, provided that such information does not contain the amounts of taxes paid nor any other information deemed by the Tax Commissioner to be confidential.

Under penalty of law for false swearing (West Virginia Code, §61-5-3), Bidder hereby certifies that this certificate is true and accurate in all respects; and that if a contract is issued to Bidder and if anything contained within this certificate changes during the term of the contract, Bidder will notify the Purchasing Division in writing immediately.

Bidder: Walker Machinery

Signed: [Signature]

Date: 1/15/2016

Title: Sales Person

STATE OF WEST VIRGINIA
Purchasing Division

PURCHASING AFFIDAVIT

MANDATE: Under W. Va. Code §5A-3-10a, no contract or renewal of any contract may be awarded by the state or any of its political subdivisions to any vendor or prospective vendor when the vendor or prospective vendor or a related party to the vendor or prospective vendor is a debtor and: (1) the debt owed is an amount greater than one thousand dollars in the aggregate; or (2) the debtor is in employer default.

EXCEPTION: The prohibition listed above does not apply where a vendor has contested any tax administered pursuant to chapter eleven of the W. Va. Code, workers' compensation premium, permit fee or environmental fee or assessment and the matter has not become final or where the vendor has entered into a payment plan or agreement and the vendor is not in default of any of the provisions of such plan or agreement.

DEFINITIONS:

"Debt" means any assessment, premium, penalty, fine, tax or other amount of money owed to the state or any of its political subdivisions because of a judgment, fine, permit violation, license assessment, defaulted workers' compensation premium, penalty or other assessment presently delinquent or due and required to be paid to the state or any of its political subdivisions, including any interest or additional penalties accrued thereon.

"Employer default" means having an outstanding balance or liability to the old fund or to the uninsured employers' fund or being in policy default, as defined in W. Va. Code § 23-2c-2, failure to maintain mandatory workers' compensation coverage, or failure to fully meet its obligations as a workers' compensation self-insured employer. An employer is not in employer default if it has entered into a repayment agreement with the Insurance Commissioner and remains in compliance with the obligations under the repayment agreement.

"Related party" means a party, whether an individual, corporation, partnership, association, limited liability company or any other form or business association or other entity whatsoever, related to any vendor by blood, marriage, ownership or contract through which the party has a relationship of ownership or other interest with the vendor so that the party will actually or by effect receive or control a portion of the benefit, profit or other consideration from performance of a vendor contract with the party receiving an amount that meets or exceeds five percent of the total contract amount.

AFFIRMATION: By signing this form, the vendor's authorized signer affirms and acknowledges under penalty of law for false swearing (W. Va. Code §61-5-3) that neither vendor nor any related party owe a debt as defined above and that neither vendor nor any related party are in employer default as defined above, unless the debt or employer default is permitted under the exception above.

WITNESS THE FOLLOWING SIGNATURE:

Vendor's Name: Walker Machinery
Authorized Signature: [Signature] Date: 1-18-16

State of WV
County of Kanawha, to-wit:

Taken, subscribed, and sworn to before me this 18th day of January, 2016.
My Commission expires September 10th, 2016.

AFFIX SEAL HERE

NOTARY PUBLIC [Signature]

Purchasing Affidavit (Revised 08/01/2015)

