



Purchasing Division  
 2019 Washington Street East  
 Post Office Box 50130  
 Charleston, WV 25305-0130

State of West Virginia  
 Request for Quotation  
 13 - Equipment

Proc Folder: 190901

Doc Description: Addendum 3 GVWR DUAL AXLE EQUIPMENT TILT DECK TRAILER

Proc Type: Central Master Agreement

Date Issued	Solicitation Closes	Solicitation No	Version
2016-06-07	2016-06-15 13:30:00	CRFQ 0803 DOT1600000094	4

**BID RECEIVING LOCATION**

BID CLERK  
 DEPARTMENT OF ADMINISTRATION  
 PURCHASING DIVISION  
 2019 WASHINGTON ST E  
 CHARLESTON WV 25305  
 US

**VENDOR**

**Vendor Name, Address and Telephone Number:**

West Virginia Tractor Company  
 P.O. Box 473  
 Charleston, WV 25322  
 304-346-5301

Bid with addendums #1 and #1 submitted earlier

06/15/16 13:12:51  
 WV Purchasing Division

**FOR INFORMATION CONTACT THE BUYER**

Misty DeLong  
 (304) 558-8802  
 misty.m.delong@wv.gov

Signature X

FEIN #

550621655

DATE

6-7-2016

All offers subject to all terms and conditions contained in this solicitation

**ADDITIONAL INFORMATION**

**Addendum 3 -**

1. To attach drawing #1 of trailer.
  2. Extend Bid opening from June 7, 2016 to June 15, 2016 at 1:30 PM, EST.
- No other changes made.

**Addendum 2 -**

1. Attach Technical Questions and responses
  2. Attach pre-bid meeting sign-in sheet.
- No other changes made.

**Addendum 1 -**

1. Extend the Mandatory Pre-bid meeting from May 17, 2016 to May 19, 2017 at 11:00 AM.
  2. Extend Technical Questions due date from May 24, 2016 to May 26, 2016.
  3. Extend Bid Opening Date from May 31, 2016 to June 7, 2016 at 1:30 PM, EST.
- No other changes made.

The West Virginia Purchasing Division is soliciting bids on behalf of the West Virginia Division of Highways, Department of Transportation to establish an open-end contract for a 45,000 GVWR Dual Axle Equipment Tilt Deck Trailer.

INVOICE TO	SHIP TO
<b>DIVISION OF HIGHWAYS</b> <b>EQUIPMENT DIVISION RT 33</b> <b>83 BRUSHY ROAD CROSSING, PO BOX 610</b> <b>BUCKHANNON WV26201</b> <b>US</b>	<b>DIVISION OF HIGHWAYS</b> <b>EQUIPMENT DIVISION</b> <b>83 BRUSHY FORK RD CROSSING</b> <b>BUCKHANNON WV 26201</b> <b>US</b>

Line	Comm Ln Desc	Qty	Unit Issue	Unit Price	Total Price
1	45,000 GVWR DUAL AXLE EQUIPMENT TILT DECK TRAILER	10.00000	EA	\$21,390.00	\$213,900.00

Comm Code	Manufacturer	Specification	Model #
25181714	Interstate Trailers	Enclosed	40TDL

**Extended Description :**

45,000 GVWR DUAL AXLE EQUIPMENT TILT DECK TRAILER

**SCHEDULE OF EVENTS**

Line	Event	Event Date
1	Mandatory Pre-bid Meeting 11:00	2016-05-19
2	Technical Questions Due	2016-05-26

**CERTIFICATION AND SIGNATURE PAGE**

By signing below, or submitting documentation through wvOASIS, I certify that I have reviewed this Solicitation in its entirety; that I understand the requirements, terms and conditions, and other information contained herein; that this bid, offer or proposal constitutes an offer to the State that cannot be unilaterally withdrawn; that the product or service proposed meets the mandatory requirements contained in the Solicitation for that product or service, unless otherwise stated herein; that the Vendor accepts the terms and conditions contained in the Solicitation, unless otherwise stated herein; that I am submitting this bid, offer or proposal for review and consideration; that I am authorized by the vendor to execute and submit this bid, offer, or proposal, or any documents related thereto on vendor's behalf; that I am authorized to bind the vendor in a contractual relationship; and that to the best of my knowledge, the vendor has properly registered with any State agency that may require registration.

West Virginia Tractor Company

(Company)



(Authorized Signature) (Representative Name, Title)  
Gary W. Grady, President

304-346-5301 304-346-5305 6-7-16

(Phone Number) (Fax Number) (Date)

**REQUEST FOR QUOTATION  
CLASS 253 45,000 GVWR DUAL AXLE TILT DECK EQUIPMENT TRAILER**

---

parts on the unit resulting from operation and testing within the limits of these specifications; nor will DOH incur obligation for damage to the unit resulting from failure to meet specifications when due care and attention is given by DOH and testing is done within the limits of these specifications. Failure of the pilot unit to satisfactorily meet specifications as bid may be cause for cancellation of the purchase order, and return of the delivered unit along with all associated equipment to the vendor at the vendor's expense.

- 6.5 Condition of Unit(s) Upon Delivery:** All units must arrive at the prescribed delivery point having been completely pre-serviced with oil, lubricants, and coolant. All prescribed precautions pertaining to first operations and break-in of the unit are to be posted conspicuously on the unit for ready observance by the operator.
- 6.6 Delivery Point:** Delivery point of the completed representative unit will be the WVDOH, Equipment Division, 83 Brushy Fork Road Crossing, Buckhannon, WV 26201.

**7. MISCELLANEOUS:**

- 7.1 No Substitutions:** Vendor shall supply only Contract Items submitted in Response to the Solicitation unless a contract modification is approved in accordance with the provisions contained in this Contract.
- 7.2 Contract Manager:** During its performance of this Contract, Vendor must designate and maintain a primary contract manager responsible for overseeing Vendor's responsibilities under this Contract. The Contract manager must be available during normal business hours to address any customer service or other issues related to this Contract. Vendor should list its Contract manager and his or her contact information below.

Gary W. Grady

**Contract Manager:** \_\_\_\_\_  
**Telephone Number:** 304-346-5301  
**Fax Number:** 304-346-5305  
**Email Address:** wvtractor@msn.com

- 7.3 Operating and Service Manuals and Parts Lists:** An operator's manual must be included with each unit upon delivery. A "line sheet" (if applicable) and the "Equipment Preventative Maintenance Questionnaire", (Exhibit "B") must be with pilot unit upon delivery, Attn: Marcia Lee. There must be 12 service/shop/

**SOLICITATION NUMBER: CRFQ DOT1600000094**

**Addendum Number: 3**

---

The purpose of this addendum is to modify the solicitation identified as ("Solicitation") to reflect the change(s) identified and described below.

**Applicable Addendum Category:**

- Modify bid opening date and time
- Modify specifications of product or service being sought
- Attachment of vendor questions and responses
- Attachment of pre-bid sign-in sheet
- Correction of error
- Other

**Description of Modification to Solicitation:**

1. To attach drawing #1 of trailer.
2. Extend Bid opening from June 7, 2016 to June 15, 2016 at 1:30 PM, EST

No other changes made.

**Additional Documentation:** Documentation related to this Addendum (if any) has been included herewith as Attachment A and is specifically incorporated herein by reference.

**Terms and Conditions:**

1. All provisions of the Solicitation and other addenda not modified herein shall remain in full force and effect.
2. Vendor should acknowledge receipt of all addenda issued for this Solicitation by completing an Addendum Acknowledgment, a copy of which is included herewith. Failure to acknowledge addenda may result in bid disqualification. The addendum acknowledgement should be submitted with the bid to expedite document processing.

**ADDENDUM ACKNOWLEDGEMENT FORM**  
**SOLICITATION NO.: DOT160000094**

**Instructions:** Please acknowledge receipt of all addenda issued with this solicitation by completing this addendum acknowledgment form. Check the box next to each addendum received and sign below. Failure to acknowledge addenda may result in bid disqualification.

**Acknowledgment:** I hereby acknowledge receipt of the following addenda and have made the necessary revisions to my proposal, plans and/or specification, etc.

**Addendum Numbers Received:**

(Check the box next to each addendum received)

- |  |  |
|--|--|
| <input checked="" type="checkbox"/> Addendum No. 1 | <input type="checkbox"/> Addendum No. 6  |
| <input type="checkbox"/> Addendum No. 2            | <input type="checkbox"/> Addendum No. 7  |
| <input checked="" type="checkbox"/> Addendum No. 3 | <input type="checkbox"/> Addendum No. 8  |
| <input type="checkbox"/> Addendum No. 4            | <input type="checkbox"/> Addendum No. 9  |
| <input type="checkbox"/> Addendum No. 5            | <input type="checkbox"/> Addendum No. 10 |

I understand that failure to confirm the receipt of addenda may be cause for rejection of this bid. I further understand that any verbal representation made or assumed to be made during any oral discussion held between Vendor's representatives and any state personnel is not binding. Only the information issued in writing and added to the specifications by an official addendum is binding.

West Virginia Tractor Company

Company



Authorized Signature

6-7-16

Date

**NOTE:** This addendum acknowledgement should be submitted with the bid to expedite document processing.

Revised 6/8/2012

# Class 253 45,000 GVWR Dual Axle Tilt Deck Equipment Trailer

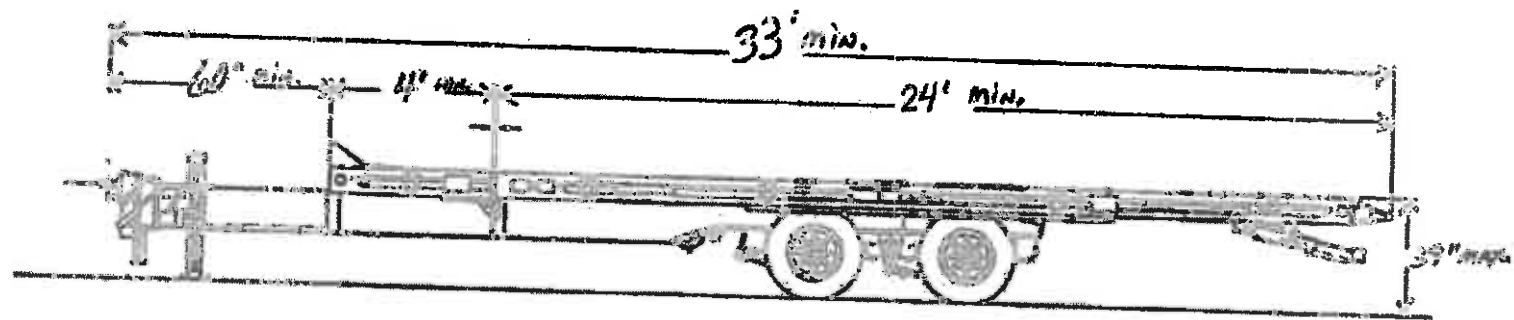

Overall Length Minimum 33' foot

Tongue Minimum 60" inches

Stationary Deck Minimum 4' foot

Tilting Deck Length Minimum 24' foot

Trailer Height Empty Maximum 39" inches

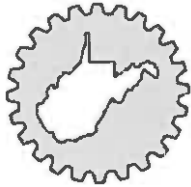

# WEST VIRGINIA TRACTOR COMPANY

CONSTRUCTION, MINING, MUNICIPAL & INDUSTRIAL EQUIPMENT

P. O. BOX 473, 214 VIRGINIA ST. W., CHARLESTON, WV 25322/25302 • (304) 346-5301

June 7, 2016

WVDOT-Highways  
Equipment Division  
P.O. Box 610  
Buckhannon, WV 26201

Subj: CRFQ DOT16\*94 - Dual Axle Tilt Deck Equipment Trailers  
Due Wednesday, June 15, 2016 at 1:30 PM

Ladies and gentlemen:

We are pleased to offer the following described equipment for your consideration:

INTERSTATE Model 40TDL 20-ton tag type tilting deck trailer with 24'0" X 102" full tilting deck plus 51.5" front stationary deck, 13 degree loading angle, 38" unloaded deck height, cantilever safety latch, NHTSA approved underride guard, Hutch 9700 multipoint springs radius rod tracking adjustment 44,000 capacity, two 22,500 lb. axles with 8-hole hub piloted steel disc wheels, 215/75R17.5-H tires, heavy duty two-speed 25,000 lb. landing gear, 2" oak decking, 12.25" X 7.5" ABS air brakes with Wabco anti-lock system and spring parking brake, LED lights, sealed modular wiring harness, ICC and DOT approved, (8) heavy duty D-rings (4 per side), rust prohibitive undercoating and all other standard equipment, plus:  
Air operated deck latch in lieu of standard  
235/75R17.5 (H) tires in lieu of standard  
Lockable tool box lid  
96" wide deck in lieu of standard  
Dual cushioning cylinders  
Decking secured with floor clips and countersunk screws  
ABS 4S2M brake system  
(8) Additional tie down rings  
45,000 lb. suspension in lieu of standard  
(2) Coats of epoxy primer and (2) coats of polyurethane  
Additional operator and parts manuals  
Delivery and training

PRICE: F.O.B. Buckhannon.....\$21,390 EACH

Availability: Currently about 90 days for pilot model and 120-150 days for remainder

Terms: Net 30 days

Parts, service and training are available through West Virginia Tractor Company in Charleston.

We meet all of your bid terms and specifications and have enclosed literature and a warranty statement



Please note that, as required West Virginia Code 5A-3-10a, we are registered to do business in West Virginia with all required agencies, including the West Virginia Secretary of State, West Virginia Tax Department, West Virginia Insurance Commission, and West Virginia Division of Motor Vehicles (DTR-1594), which is a requirement under West Virginia code.

We qualify for and request the State of West Virginia resident vendor preference in accordance with West Virginia Code 5A-3-37.

West Virginia Tractor Company is an Equal Opportunity Employer and does not discriminate against any employee or applicant for employment because of race, religion, color, sex, handicap or national origin. We are also in compliance with West Virginia Code 21A-2-6, Unemployment and Workers Compensation status with the Bureau of Employment Programs.

Thank you very much for your consideration. If you have any questions or need any additional information, please feel free to call me on our toll free number, 1 800 640-8245, at any time. We also invite your to visit us at [www.wvtractor.com](http://www.wvtractor.com). Again, thanks.

Sincerely,

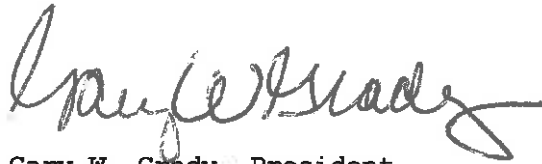
A handwritten signature in cursive script, appearing to read "Gary W. Grady". The signature is written in dark ink and is positioned above the printed name.

Gary W. Grady, President

387022

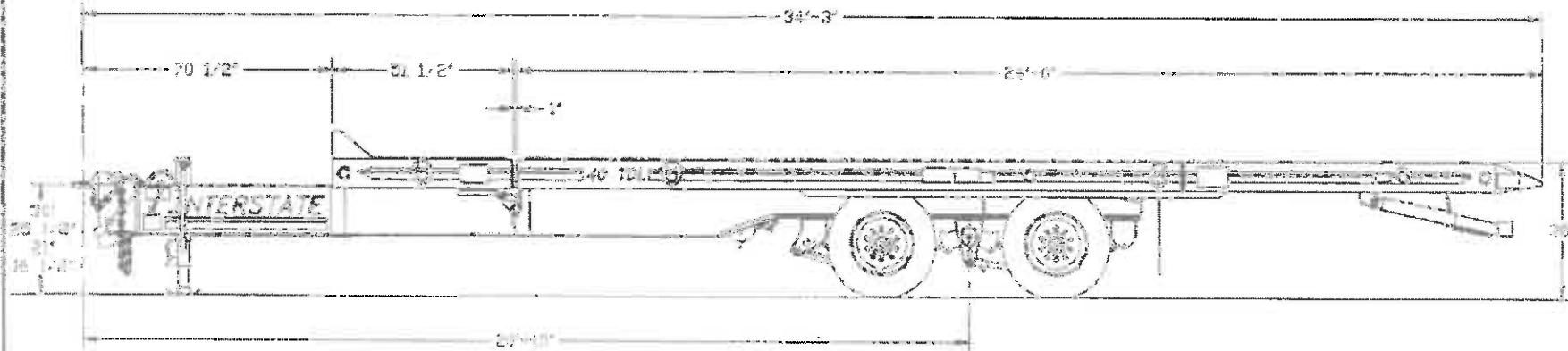
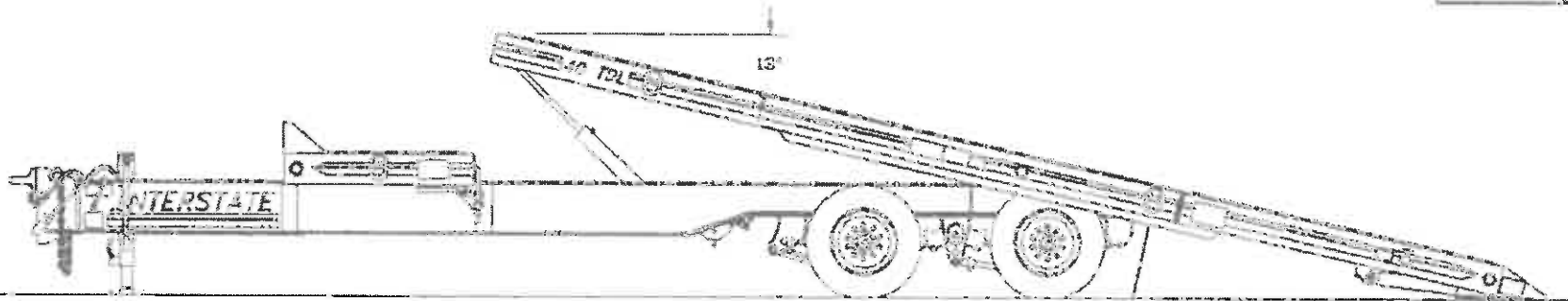

REVISIONS		
NO.	DATE	BY
1		
2		
3		
4		
5		
6		

**INTERSTATE TRAILERS, INC.**  
 MCKENZIE, TEXAS \* (817) 402-0402

DATE: 1-30 APPROVED BY: \_\_\_\_\_ DRAWN BY: BANC

DATE: 5-7-93

TITLE: **40 TDL - 4' STAT/24' TILT**

REFERENCE: SALES DRAWING

Drawing Number: **387022**

INTERSTATE TRAILERS, INC. RESERVES THE RIGHT TO CHANGE DESIGN, MATERIAL AND/OR SPECIFICATIONS WITHOUT NOTICE AND WITHOUT INCURRING ANY OBLIGATION TO SUCH CHANGES.

THIS DRAWING CONTAINS CONFIDENTIAL INFORMATION AND IS THE SOLE PROPERTY OF INTERSTATE TRAILERS, INC. AND IS NOT TO BE COPIED OR REPRODUCED WITHOUT THE EXPRESS PERMISSION OF INTERSTATE TRAILERS, INC.

# INTERSTATE



## 40TDL

THE  
DEFINITION  
OF VALUE

TAPERED REAR END  
WITH RECESSED  
LIGHTS

LED LIGHTS & SEALED  
MODULAR WIRING

HEAVY DUTY SPRING  
SUSPENSION

(2) HEAVY DUTY  
CUSHION CYLINDERS

8 HOLE, HUB PILOTTED  
STEEL DISC WHEELS

STRAIGHT-THRU  
CHASSIS DESIGN

UNDERCOATED



TRAILERS, INC. 1101 HERITAGE PARKWAY MANSFIELD, TEXAS 76063

Visit our Web site at [www.interstatetrailers.com](http://www.interstatetrailers.com)

817/453-5402

800/433-5384

Fax: 817/453-5445

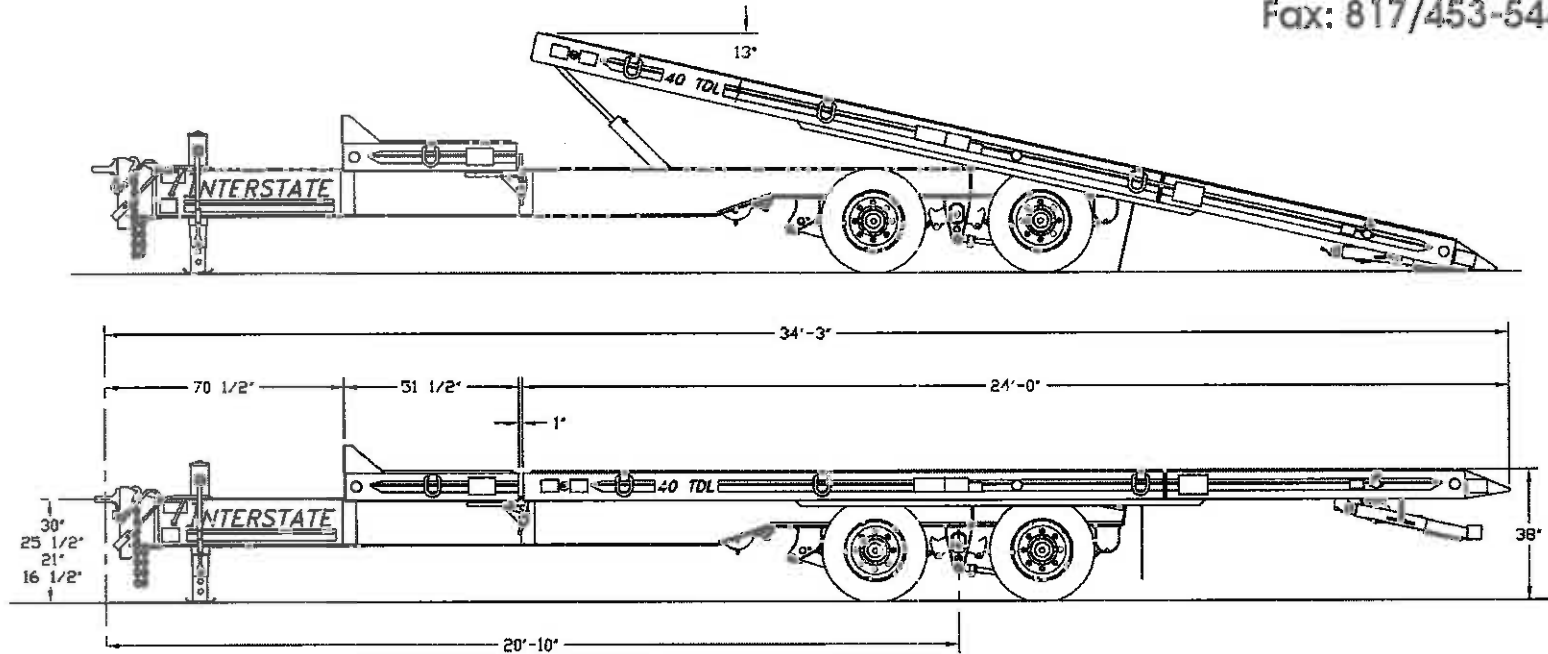

### MODEL 40TDL

CAPACITY:	40,000# @ 55 MPH	Crossmembers:	Tilt Bed - S6" x 12.5# A572 Gr.50
Trailer Weight:	10,000#		High Tensile
Overall Length:	34' 3"	Chassis:	4" x 4" Rectangular Tube A500B
Overall Width:	102"	Heavy Duty Axles:	(2) 22,500#
Tilt Deck Length:	24' 0"	Heavy Duty Brakes:	12 1/2" x 7 1/2" Air - ABS Spring Parking Brakes on both Axles
Stationary Deck:	51 1/2"	Heavy Duty Suspension:	Hutch 9700
Platform Height:	38"	Tires:	(8) 215/75R x 17.5 - 16Ply Radials
Decking:	2" Nominal Hardwood	Heavy Duty Wheels:	8 Hole, Hub Piloted Steel Disc
Hitch:	Adjustable Pintle Eye	Lights & Electric:	LED Lights and Sealed, Modular Wiring Harness, ICC & DOT Approved
Main Rails:	Tilt Bed W-8" x 15# A572 Gr 50 High Tensile	Heavy Duty Jack:	25,000# Two Speed Jack
Chassis:	W14" x 26# A572 Gr 50 High Tensile		

Your **INTERSTATE** Dealer Is

Interstate Trailers, Inc. reserves the right to change design, material and/or specifications without notice and without incurring any obligation to such changes.

# State of West Virginia

## VENDOR PREFERENCE CERTIFICATE

Certification and application is hereby made for Preference in accordance with **West Virginia Code**, §5A-3-37. (Does not apply to construction contracts). **West Virginia Code**, §5A-3-37, provides an opportunity for qualifying vendors to request (at the time of bid) preference for their residency status. Such preference is an evaluation method only and will be applied only to the cost bid in accordance with the **West Virginia Code**. This certificate for application is to be used to request such preference. The Purchasing Division will make the determination of the Vendor Preference, if applicable.

1. **Application is made for 2.5% vendor preference for the reason checked:**  
 Bidder is an individual resident vendor and has resided continuously in West Virginia for four (4) years immediately preceding the date of this certification; **or**,  
 Bidder is a partnership, association or corporation resident vendor and has maintained its headquarters or principal place of business continuously in West Virginia for four (4) years immediately preceding the date of this certification;  
 Bidder is a resident vendor partnership, association, or corporation with at least eighty percent of ownership interest of bidder held by another entity that meets the applicable four year residency requirement; **or**,  
 Bidder is a nonresident vendor which has an affiliate or subsidiary which employs a minimum of one hundred state residents and which has maintained its headquarters or principal place of business within West Virginia continuously for the four (4) years immediately preceding the date of this certification; **or**,
2. **Application is made for 2.5% vendor preference for the reason checked:**  
 Bidder is a resident vendor who certifies that, during the life of the contract, on average at least 75% of the employees working on the project being bid are residents of West Virginia who have resided in the state continuously for the two years immediately preceding submission of this bid; **or**,
3. **Application is made for 2.5% vendor preference for the reason checked:**  
 Bidder is a nonresident vendor that employs a minimum of one hundred state residents, or a nonresident vendor which has an affiliate or subsidiary which maintains its headquarters or principal place of business within West Virginia and employs a minimum of one hundred state residents, and for purposes of producing or distributing the commodities or completing the project which is the subject of the bidder's bid and continuously over the entire term of the project, on average at least seventy-five percent of the bidder's employees or the bidder's affiliate's or subsidiary's employees are residents of West Virginia who have resided in the state continuously for the two immediately preceding years and the vendor's bid; **or**,
4. **Application is made for 5% vendor preference for the reason checked:**  
 Bidder meets either the requirement of both subdivisions (1) and (2) or subdivision (1) and (3) as stated above; **or**,
5. **Application is made for 3.5% vendor preference who is a veteran for the reason checked:**  
 Bidder is an individual resident vendor who is a veteran of the United States armed forces, the reserves or the National Guard and has resided in West Virginia continuously for the four years immediately preceding the date on which the bid is submitted; **or**,
6. **Application is made for 3.5% vendor preference who is a veteran for the reason checked:**  
 Bidder is a resident vendor who is a veteran of the United States armed forces, the reserves or the National Guard, if, for purposes of producing or distributing the commodities or completing the project which is the subject of the vendor's bid and continuously over the entire term of the project, on average at least seventy-five percent of the vendor's employees are residents of West Virginia who have resided in the state continuously for the two immediately preceding years.
7. **Application is made for preference as a non-resident small, women- and minority-owned business, in accordance with West Virginia Code §5A-3-59 and West Virginia Code of State Rules.**  
 Bidder has been or expects to be approved prior to contract award by the Purchasing Division as a certified small, women- and minority-owned business.

Bidder understands if the Secretary of Revenue determines that a Bidder receiving preference has failed to continue to meet the requirements for such preference, the Secretary may order the Director of Purchasing to: (a) rescind the contract or purchase order; or (b) assess a penalty against such Bidder in an amount not to exceed 5% of the bid amount and that such penalty will be paid to the contracting agency or deducted from any unpaid balance on the contract or purchase order.

By submission of this certificate, Bidder agrees to disclose any reasonably requested information to the Purchasing Division and authorizes the Department of Revenue to disclose to the Director of Purchasing appropriate information verifying that Bidder has paid the required business taxes, provided that such information does not contain the amounts of taxes paid nor any other information deemed by the Tax Commissioner to be confidential.

**Bidder hereby certifies that this certificate is true and accurate in all respects; and that if a contract is issued to Bidder and if anything contained within this certificate changes during the term of the contract, Bidder will notify the Purchasing Division in writing immediately.**

Bidder: West Virginia Tractor Company

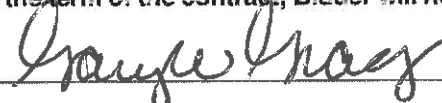
Signed: 

Date: 6-15-2016

Title: President

\*Check any combination of preference consideration(s) indicated above, which you are entitled to receive.

STATE OF WEST VIRGINIA  
Purchasing Division

# PURCHASING AFFIDAVIT

**MANDATE:** Under W. Va. Code §5A-3-10a, no contract or renewal of any contract may be awarded by the state or any of its political subdivisions to any vendor or prospective vendor when the vendor or prospective vendor or a related party to the vendor or prospective vendor is a debtor and: (1) the debt owed is an amount greater than one thousand dollars in the aggregate; or (2) the debtor is in employer default.

**EXCEPTION:** The prohibition listed above does not apply where a vendor has contested any tax administered pursuant to chapter eleven of the W. Va. Code, workers' compensation premium, permit fee or environmental fee or assessment and the matter has not become final or where the vendor has entered into a payment plan or agreement and the vendor is not in default of any of the provisions of such plan or agreement.

**DEFINITIONS:**

**"Debt"** means any assessment, premium, penalty, fine, tax or other amount of money owed to the state or any of its political subdivisions because of a judgment, fine, permit violation, license assessment, defaulted workers' compensation premium, penalty or other assessment presently delinquent or due and required to be paid to the state or any of its political subdivisions, including any interest or additional penalties accrued thereon.

**"Employer default"** means having an outstanding balance or liability to the old fund or to the uninsured employers' fund or being in policy default, as defined in W. Va. Code § 23-2c-2, failure to maintain mandatory workers' compensation coverage, or failure to fully meet its obligations as a workers' compensation self-insured employer. An employer is not in employer default if it has entered into a repayment agreement with the Insurance Commissioner and remains in compliance with the obligations under the repayment agreement.

**"Related party"** means a party, whether an individual, corporation, partnership, association, limited liability company or any other form or business association or other entity whatsoever, related to any vendor by blood, marriage, ownership or contract through which the party has a relationship of ownership or other interest with the vendor so that the party will actually or by effect receive or control a portion of the benefit, profit or other consideration from performance of a vendor contract with the party receiving an amount that meets or exceeds five percent of the total contract amount.

**AFFIRMATION:** By signing this form, the vendor's authorized signer affirms and acknowledges under penalty of law for false swearing (W. Va. Code §61-5-3) that neither vendor nor any related party owe a debt as defined above and that neither vendor nor any related party are in employer default as defined above, unless the debt or employer default is permitted under the exception above.

**WITNESS THE FOLLOWING SIGNATURE:**

Vendor's Name: West Virginia Tractor Company

Authorized Signature: *Graefe Tracy* Date: 6-15-2016

State of West Virginia

County of Kanawha, to-wit:

Taken, subscribed, and sworn to before me this 15 day of June, 2016.

My Commission expires August 12, 2022.

**AFFIX SEAL HERE**

**NOTARY PUBLIC**

*Steven B. Basham*

*Purchasing Affidavit (Revised 08/01/2015)*

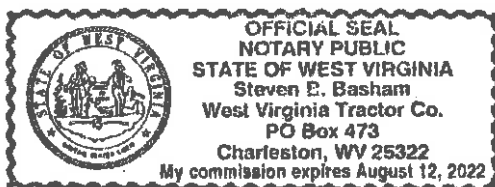



Purchasing Division  
 2019 Washington Street East  
 Post Office Box 50130  
 Charleston, WV 25305-0130

State of West Virginia  
 Request for Quotation  
 f3 - Equipment

Proc Folder: 190901

Doc Description: Addendum 2 GVWR DUAL AXLE EQUIPMENT TILT DECK TRAILER

Proc Type: Central Master Agreement

Date Issued	Solicitation Closes	Solicitation No	Version
2016-05-31	2016-06-07 13:30:00	CRFQ 0803 DOT1600000094	3

**BID RECEIVING LOCATION**

BID CLERK  
 DEPARTMENT OF ADMINISTRATION  
 PURCHASING DIVISION  
 2019 WASHINGTON ST E  
 CHARLESTON WV 25305  
 US

**VENDOR**

Vendor Name, Address and Telephone Number:

West Virginia Tractor Company  
 P.O. Box 473  
 Charleston, WV 25322  
  
 304-346-5301

06/06/16 14:02:48  
 WV Purchasing Division

**FOR INFORMATION CONTACT THE BUYER**

Misty Delong  
 (304) 558-8802  
 misty.m.delong@wv.gov

Signature X *[Handwritten Signature]* FEIN # 550621655 DATE 6-1-2016

All offers subject to all terms and conditions contained in this solicitation

**ADDITIONAL INFORMATION**

**Addendum 2 - 1**

1. Attach Technical Questions and responses
  2. Attach pre-bid meeting sign-in sheet.
- No other changes made.

**Addendum 1 -**

1. Extend the Mandatory Pre-bid meeting from May 17, 2016 to May 19, 2017 at 11:00 AM.
  2. Extend Technical Questions due date from May 24, 2016 to May 26, 2016.
  3. Extend Bid Opening Date from May 31, 2016 to June 7, 2016 at 1:30 PM, EST.
- No other changes made.

The West Virginia Purchasing Division is soliciting bids on behalf of the West Virginia Division of Highways, Department of Transportation to establish an open-end contract for a 45,000 GVWR Dual Axle Equipment Tilt Deck Trailer.

INVOICE TO	SHIP TO
DIVISION OF HIGHWAYS EQUIPMENT DIVISION RT 33 83 BRUSHY ROAD CROSSING, PO BOX 610 BUCKHANNON WV26201 US	DIVISION OF HIGHWAYS EQUIPMENT DIVISION 83 BRUSHY FORK RD CROSSING BUCKHANNON WV 26201 US

Line	Comm Ln Desc	Qty	Unit Issue	Unit Price	Total Price
1	45,000 GVWR DUAL AXLE EQUIPMENT TILT DECK TRAILER	10.00000	EA	\$21,390.00	\$213,900.00

Comm Code	Manufacturer	Specification	Model #
25181714	Interstate Trailers	Enclosed	40TDL

**Extended Description :**

45,000 GVWR DUAL AXLE EQUIPMENT TILT DECK TRAILER

**SCHEDULE OF EVENTS**

Line	Event	Event Date
1	Mandatory Pre-bid Meeting 11:00	2016-05-19
2	Technical Quesitons Due	2016-05-26



**CERTIFICATION AND SIGNATURE PAGE**

By signing below, or submitting documentation through wvOASIS, I certify that I have reviewed this Solicitation in its entirety; that I understand the requirements, terms and conditions, and other information contained herein; that this bid, offer or proposal constitutes an offer to the State that cannot be unilaterally withdrawn; that the product or service proposed meets the mandatory requirements contained in the Solicitation for that product or service, unless otherwise stated herein; that the Vendor accepts the terms and conditions contained in the Solicitation, unless otherwise stated herein; that I am submitting this bid, offer or proposal for review and consideration; that I am authorized by the vendor to execute and submit this bid, offer, or proposal, or any documents related thereto on vendor's behalf; that I am authorized to bind the vendor in a contractual relationship; and that to the best of my knowledge, the vendor has properly registered with any State agency that may require registration.

West Virginia Tractor Company

(Company)



(Authorized Signature) (Representative Name, Title)

Gary W. Grady, President  
304-346-5301      304-346-5305

(Phone Number) (Fax Number) (Date)

**REQUEST FOR QUOTATION  
CLASS 253 45,000 GVWR DUAL AXLE TILT DECK EQUIPMENT TRAILER**

---

parts on the unit resulting from operation and testing within the limits of these specifications; nor will DOH incur obligation for damage to the unit resulting from failure to meet specifications when due care and attention is given by DOH and testing is done within the limits of these specifications. Failure of the pilot unit to satisfactorily meet specifications as bid may be cause for cancellation of the purchase order, and return of the delivered unit along with all associated equipment to the vendor at the vendor's expense.

- 6.5 Condition of Unit(s) Upon Delivery:** All units must arrive at the prescribed delivery point having been completely pre-serviced with oil, lubricants, and coolant. All prescribed precautions pertaining to first operations and break-in of the unit are to be posted conspicuously on the unit for ready observance by the operator.
- 6.6 Delivery Point:** Delivery point of the completed representative unit will be the WVDOH, Equipment Division, 83 Brushy Fork Road Crossing, Buckhannon, WV 26201.

**7. MISCELLANEOUS:**

- 7.1 No Substitutions:** Vendor shall supply only Contract Items submitted in Response to the Solicitation unless a contract modification is approved in accordance with the provisions contained in this Contract.
- 7.2 Contract Manager:** During its performance of this Contract, Vendor must designate and maintain a primary contract manager responsible for overseeing Vendor's responsibilities under this Contract. The Contract manager must be available during normal business hours to address any customer service or other issues related to this Contract. Vendor should list its Contract manager and his or her contact information below.

Contract Manager: Gary W. Grady  
Telephone Number: 304-346-5301  
Fax Number: 304-346-5305  
Email Address: wytractor@msn.com

- 7.3 Operating and Service Manuals and Parts Lists:** An operator's manual must be included with each unit upon delivery. A "line sheet" (if applicable) and the "Equipment Preventative Maintenance Questionnaire", (Exhibit "B") must be with pilot unit upon delivery. Attn: Marcia Lee. There must be 12 service/shop/

**ADDENDUM ACKNOWLEDGEMENT FORM**  
**SOLICITATION NO.: DOT1600000093**

**Instructions:** Please acknowledge receipt of all addenda issued with this solicitation by completing this addendum acknowledgment form. Check the box next to each addendum received and sign below. Failure to acknowledge addenda may result in bid disqualification.

**Acknowledgment:** I hereby acknowledge receipt of the following addenda and have made the necessary revisions to my proposal, plans and/or specification, etc.

**Addendum Numbers Received:**

(Check the box next to each addendum received)

- |  |  |
|--|--|
| <input checked="" type="checkbox"/> Addendum No. 1 | <input type="checkbox"/> Addendum No. 6  |
| <input checked="" type="checkbox"/> Addendum No. 2 | <input type="checkbox"/> Addendum No. 7  |
| <input type="checkbox"/> Addendum No. 3            | <input type="checkbox"/> Addendum No. 8  |
| <input type="checkbox"/> Addendum No. 4            | <input type="checkbox"/> Addendum No. 9  |
| <input type="checkbox"/> Addendum No. 5            | <input type="checkbox"/> Addendum No. 10 |

I understand that failure to confirm the receipt of addenda may be cause for rejection of this bid. I further understand that any verbal representation made or assumed to be made during any oral discussion held between Vendor's representatives and any state personnel is not binding. Only the information issued in writing and added to the specifications by an official addendum is binding.

West Virginia Tractor Company

\_\_\_\_\_  
Company

  
Authorized Signature

6-1-2016

\_\_\_\_\_  
Date

**NOTE:** This addendum acknowledgment should be submitted with the bid to expedite document processing.  
Revised 6/8/2012

Exhibit A

### Pricing Sheet

Item Number	Estimated Quantity	Unit of Measure	Description	Unit Price	Total
1	10	Each	One complete unit: 45,000 GVWR Dual Axle Equipment Tilt Deck Trailer	\$21,390.00	\$213,900.00
				Grand Total	\$213,900.00

Vendor should also supply the year, make, and model of the following: Interstate Trailers Model 40TDL  
2016 or later as ordered

45,000 GVWR Dual Axle Equipment Tilt Deck Trailer

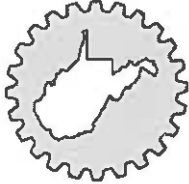

**WEST VIRGINIA  
TRACTOR COMPANY**  
CONSTRUCTION, MINING, MUNICIPAL & INDUSTRIAL EQUIPMENT

P. O. BOX 473, 214 VIRGINIA ST. W., CHARLESTON, WV 25322/25302 • (304) 346-5301

June 1, 2016

WV DOT-Highways  
Equipment Division  
P.O. Box 610  
Buckhannon, WV 26201

Subj: CRFQ DOT16\*94 - Dual Axle Tilt Deck Equipment Trailers  
Due Tuesday, June 7, 2016 at 1:30 PM

Ladies and gentlemen:

We are pleased to offer the following described equipment for your consideration:

INTERSTATE Model 40TDL 20-ton tag type tilting deck trailer with 24'0" X 102" full tilting deck plus 51.5" front stationary deck, 13 degree loading angle, 38" unloaded deck height, cantilever safety latch, NHTSA approved underride guard, Hutch 9700 multipoint springs radius rod tracking adjustment 44,000 capacity, two 22,500 lb. axles with 8-hole hub piloted steel disc wheels, 215/75R17.5-H tires, heavy duty two-speed 25,000 lb. landing gear, 2" oak decking, 12.25" X 7.5" ABS air brakes with Wabco anti-lock system and spring parking brake, LED lights, sealed modular wiring harness, ICC and DOT approved, (8) heavy duty D-rings (4 per side), rust prohibitive undercoating and all other standard equipment, plus:  
Air operated deck latch in lieu of standard  
235/75R17.5 (H) tires in lieu of standard  
Lockable tool box lid  
96" wide deck in lieu of standard  
Dual cushioning cylinders  
Decking secured with floor clips and countersunk screws  
ABS 4S2M brake system  
(8) Additional tie down rings  
45,000 lb. suspension in lieu of standard  
(2) Coats of epoxy primer and (2) coats of polyurethane  
Additional operator and parts manuals  
Delivery and training

PRICE: F.O.B. Buckhannon.....\$21,390 EACH

Availability: Currently about 90 days for pilot model and 120-150 days for remainder

Terms: Net 30 days

Parts, service and training are available through West Virginia Tractor Company in Charleston.

We meet all of your bid terms and specifications and have enclosed literature and a warranty statement

Please note that, as required West Virginia Code 5A-3-10a, we are registered to do business in West Virginia with all required agencies, including the West Virginia Secretary of State, West Virginia Tax Department, West Virginia Insurance Commission, and West Virginia Division of Motor Vehicles (DTR-1594), which is a requirement under West Virginia code.

We qualify for and request the State of West Virginia resident vendor preference in accordance with West Virginia Code 5A-3-37.

West Virginia Tractor Company is an Equal Opportunity Employer and does not discriminate against any employee or applicant for employment because of race, religion, color, sex, handicap or national origin. We are also in compliance with West Virginia Code 21A-2-6, Unemployment and Workers Compensation status with the Bureau of Employment Programs.

Thank you very much for your consideration. If you have any questions or need any additional information, please feel free to call me on our toll free number, 1 800 640-8245, at any time. We also invite you to visit us at [www.wvtractor.com](http://www.wvtractor.com). Again, thanks.

Sincerely,

A handwritten signature in cursive script, appearing to read "Gary W. Grady".

Gary W. Grady, President

# INTERSTATE



## 40TDL

THE  
DEFINITION  
OF VALUE

TAPERED REAR END  
WITH RECESSED  
LIGHTS

LED LIGHTS & SEALED  
MODULAR WIRING

HEAVY DUTY SPRING  
SUSPENSION

(2) HEAVY DUTY  
CUSHION CYLINDERS

8 HOLE, HUB PILOTED  
STEEL DISC WHEELS

STRAIGHT-THRU  
CHASSIS DESIGN

UNDERCOATED

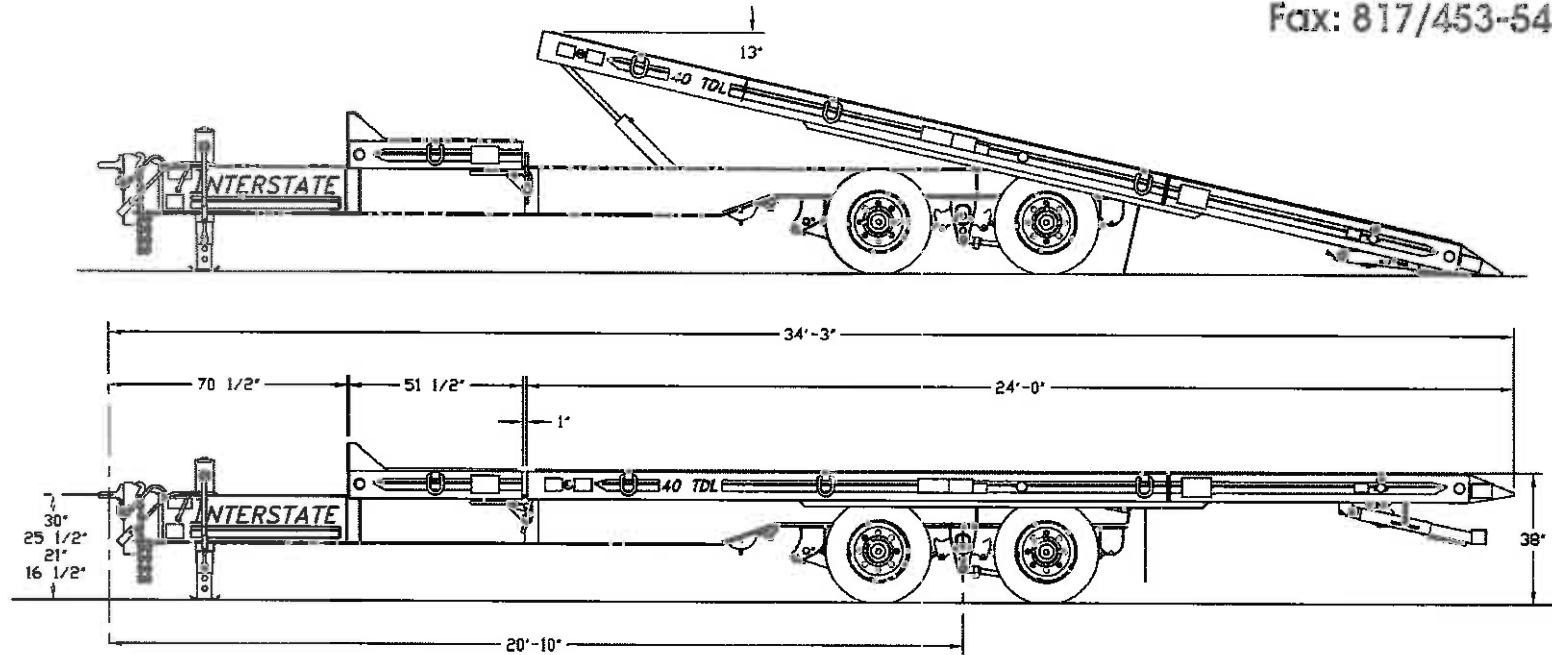

**MODEL 40TDL**

CAPACITY:	40,000# @ 55 MPH	Crossmembers:	Tilt Bed - S6' x 12.5# A572 Gr.50 High Tensile
Trailer Weight:	10,000#	Chassis:	4' x 4' Rectangular Tube A500B
Overall Length:	34' 3"	Heavy Duty Axles:	(2) 22,500#
Overall Width:	102"	Heavy Duty Brakes:	12 1/2" x 7 1/2" Air - ABS Spring Parking Brakes on both Axles
Tilt Deck Length:	24' 0"	Heavy Duty Suspension:	Hutch 9700
Stationary Deck:	51 1/2"	Tires:	(8) 215/75R x 17.5 - 16Ply Radials
Platform Height:	38"	Heavy Duty Wheels:	8 Hole, Hub Piloted Steel Disc
Decking:	2" Nominal Hardwood	Lights & Electric:	LED Lights and Sealed, Modular Wiring Harness, ICC & DOT Approved
Hitch:	Adjustable Pintle Eye	Heavy Duty Jack:	25,000# Two Speed Jack
Main Rails:	Tilt Bed W-8" x 15# A572 Gr 50 High Tensile		
Chassis:	W14" x 26# A572 Gr 50 High Tensile		

Your **INTERSTATE** Dealer Is

Interstate Trailers, Inc. reserves the right to change design, material and/or specifications without notice and without incurring any obligation to wish changes.



## **SALES ALERT**

**Subject: New federal mandates in the trailer industry.**

**1. Anti-lock braking system (ABS) FMVSS-121**

The new federal mandate FMVSS-121 goes into effect on March 1, 1998 requiring all trailers with air brake systems manufactured after this date to include an anti-lock braking system. Electric brake systems will be exempt. The mandate requires the system to control the brakes on at least one axle. Interstate has taken the position that from a liability and performance standpoint it would be in the best interest of all parties (manufacture, distributor and end user) to include a system that controls the brakes of all axles on the trailer. Many trailer manufactures will choose to install a system meeting only the minimum requirements and your customer should be made aware of this during the decision making process.

**2. Spring parking brakes. FMVSS-121**

Included in federal mandate FMVSS-121 is the requirement for a mechanical means to hold the parking brake application with sufficient parking retardation force to meet a minimum performance specification. In order to comply with this requirement Interstate is now installing spring parking brakes on all axles of its air brake trailers. We have been made aware through reliable sources that some trailer manufactures, under false assumption, claim to be exempt to this mandate and have chosen not to include spring parking brakes on their air brake trailers. We have contacted the "National Highway Traffic Safety Administration" directly and received confirmation that no trailer manufacture is exempt from this ruling. Once again please make your customer aware of these circumstances.

**3. Rear impact guards. FMVSS-223, FMVSS-224**

Federal mandates FMVSS-223 & FMVSS-224 effective January 26, 1998 are two safety standards intended to reduce the incidence of rear underride during car-trailer collisions. Mandate FMVSS-223 is an equipment standard that sets specific requirements that an underride guard must meet before being installed on a trailer. The traditional "Flip tail" design used by many manufactures may not meet these requirements. FMVSS-224 is a mandate that requires the installation of an underride guard meeting the requirements set in mandate FMVSS-223 above. Interstate has developed, tested and is now installing an underride protection system that has met the "National Highway Traffic Safety Administration" standards. There are still many manufactures that have not developed an underride protection system to meet the minimum requirements of FMVSS-223. We encourage your customers to request an authorized statement from the manufacture guaranteeing compliance with this mandate.

# **INTERSTATE** TRAILERS, INC.

---

1101 Heritage Parkway • Mansfield, Texas 76063 • 817-453-5402 • Fax 817-453-5445

February 23, 1998

Subject: Underride Protection System.

Interstate Trailers, Inc. is pleased to announce that it has developed and tested an underride protection system that meets all the requirements outlined in the National Highway Traffic Safety Administration mandate FMVSS-223 and is now installing it on all tiltdeck trailers manufactured.

Testing of the system was performed by MGA Research Corporation, Burlington, WI on January 15, 1998. MGA Research, a leading independent service organization specializing in transportation safety, recently completed a program in conjunction with the National Highway Traffic Safety Administration to develop a laboratory test procedure for FMVSS-223.

Interstate Trailer's underride protection system has met all requirements set forth in FMVSS-223 and maintains a copy of the test results on file should the need for review ever arise. Please accept this letter as our guarantee of compliance to Federal Motor Vehicle Safety Standard (FMVSS) 223.

Interstate Trailers, Inc.



mga research corporation

FMVSS 223

STRENGTH AND ENERGY ABSORPTION TESTS

INTERSTATE TRAILER, INC.

REAR UNDERRIDE BUMPER

Test Date: January 15, 1998

Report Date: January 23, 1998

Prepared for:  
Interstate Trailers Inc.  
1102 Interstate 20 West  
Arlington, TX 76017

Prepared by:  
MGA Research Corporation  
5000 Warren Road  
Burlington, WI 53105

## INTRODUCTION

A guard energy absorption and guard strength tests were conducted on a Interstate Trailer Rear Impact Guard. The tests were performed on January 15, 1998 at MGA Research Corporation according to the Laboratory Test Procedure for Federal Motor Vehicle Safety Standard 223 dated October 20, 1997. The trailer guard unit was supplied by Interstate Trailer Inc.

MGA does not endorse or certify products. The manufacturer's name appears solely for identification purposes only.

## TEST SUMMARY

The rear underride guard was attached to the rear section of the trailer. The rear section was welded upside down to the rigid test fixture along the longitudinal structural beams.

An energy absorption test at location P3 and guard strength tests at P1 and P2 were performed. All tests were performed on the same unit.

A hydraulic cylinder was used to apply the load at a rate of 3 in/min. An 8 inch square force application device was attached to the cylinder. A load cell and displacement transducer were attached to the force application device to record force and displacement at a sampling rate of 5 hz. A guard strength test was performed by applying force to the guard until the load exceeded 11,241 lbs. or the displacement exceeded 5 in. Once either of these criteria was met, the cylinder was retracted. For the energy absorption tests the load was applied for 5 inches and then removed.

## TEST RESULTS

Tables 1 and Table 2 below summarize the data recorded during each test.

Table 1-Guard Strength Tests

Test No.	Test Location	Displacement At Maximum Load (in.)	Maximum Load (lbs.)
1	P2	0.78	12,534
2	P1	3.04	11,869
3	P3	4.80	25,995

Table 2-Energy Absorption Test

(test performed at location P3 Left)

Test No.	Energy Absorption (in-lbs)
3	64,090

The energy absorption was calculated by determining the area below the force vs. displacement curve by the Trapezoid Rule.

## CALIBRATION INFORMATION

	50,000.lb. LOAD CELL	24" LINEAR MOTION TRANSDUCER
Manufacturer	Interface	Patriot
Model No.	1220AF-50K	P-30A
Serial No.	89539A	18389
DLR	10,499	6.11 in./Volt
Calibration Date	October 14, 1997	January 9, 1998

FMVSS 223 Guard Strength @ P2  
Interstate Underride Guard Unit 1

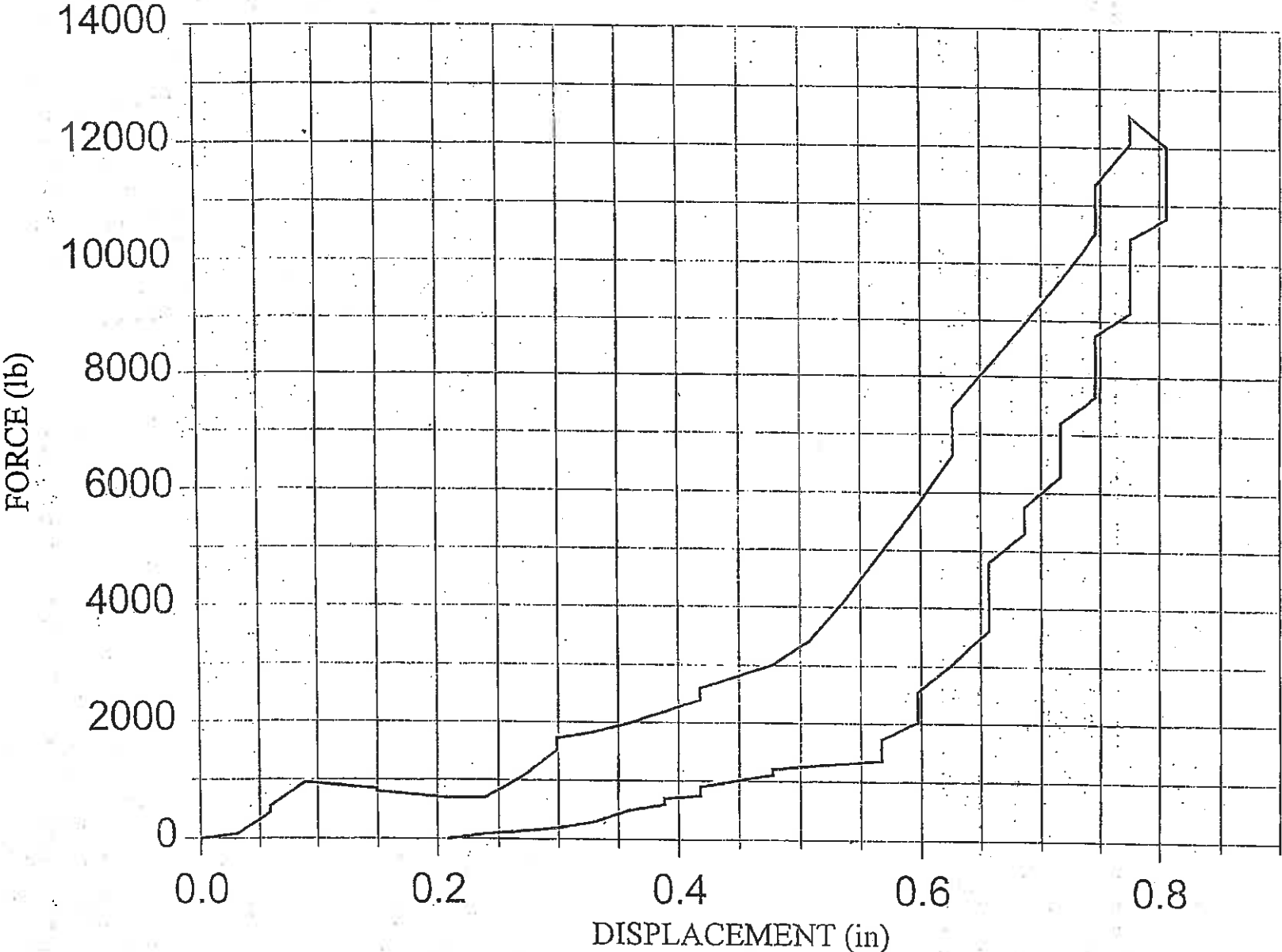



FMVSS 223 Energy Absorption @ P3 Left  
Interstate Underride Guard Unit 1

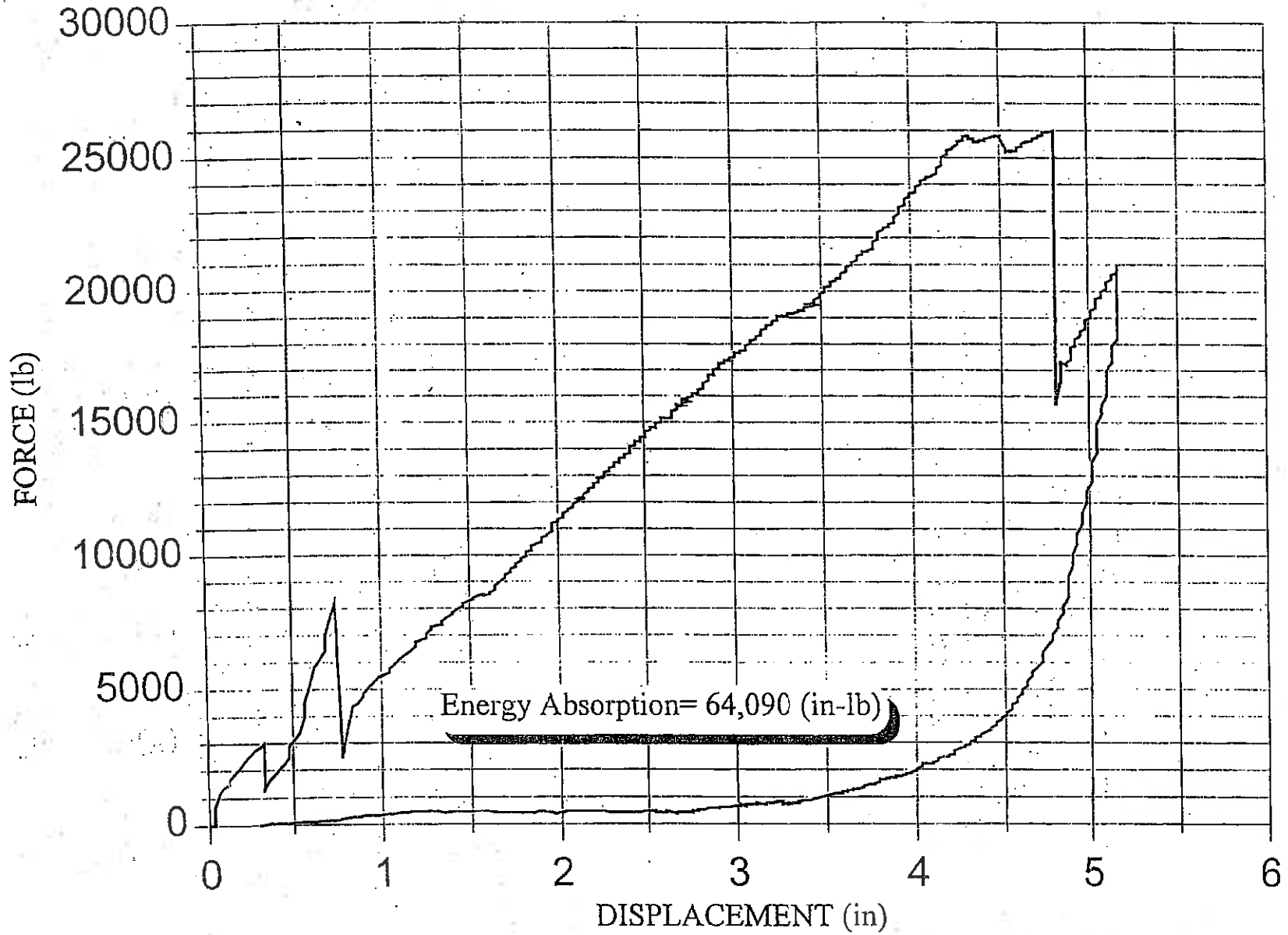

# **INTERSTATE** TRAILERS, Inc.

## **LIMITED WARRANTY**

Interstate Trailers, Inc. warrants each new vehicle manufactured by us to be free from defects in material and workmanship under normal use and service for a period of one year from date of delivery to the original purchaser.

Our obligation under this warranty is to replace free of charge, FOB our factories or at our dealers place of business, any part proven defective within the time limit of this warranty. Interstate Trailers must receive immediate notification of a defect and must give written authorization before any repairs are made.

Interstate Trailers' warranty does **NOT** cover: (1) New products which have been operated in excess of rated capacities, (2) Misuse or accidents, (3) Vehicles which have been altered, modified or repaired in any manner not authorized by our company, (4) Second hand or used vehicle. In no way will Interstate Trailers be held liable for consequential damages such as rentals of substitute vehicles, loss of profits or other commercial losses or for damage by flood, fire or act of God.

Suspension alignments required as a result of a manufacturing deficiency are covered for 30 days after delivery to end user. Thereafter, all adjustments will be considered owner maintenance responsibility.

Further, new vehicle tires are warranted by their respective manufacturers and are not warranted by Interstate Trailers. Interstate Trailers will handle disposition of warranties on all other purchased components such as axles, suspensions, wheels and other purchased parts in conjunction with their respective manufacturers, and under the terms of their respective warranty policies.

Interstate Trailers, Inc. reserves the right to make changes in design and changes or improvements upon its equipment without imposing obligations upon itself to install the same upon its products theretofore manufactured.

**THIS WARRANTY IS IN LIEU OF ALL OTHER WARRANTIES, EXPRESS OR IMPLIED BY LAW OR OTHERWISE, AND THERE IS NO WARRANTY OF MERCHANTABILITY OR FITNESS OF PURPOSE.**

### **Customer Registration Required By Law**

Federal regulations require motor vehicle manufacturers to maintain a record of original owners of their equipment. Our Warranty Registration fulfills this requirement. Please make every effort to complete this document.

# State of West Virginia

## VENDOR PREFERENCE CERTIFICATE

Certification and application is hereby made for Preference in accordance with **West Virginia Code, §5A-3-37**. (Does not apply to construction contracts). **West Virginia Code, §5A-3-37**, provides an opportunity for qualifying vendors to request (at the time of bid) preference for their residency status. Such preference is an evaluation method only and will be applied only to the cost bid in accordance with the **West Virginia Code**. This certificate for application is to be used to request such preference. The Purchasing Division will make the determination of the Vendor Preference, if applicable.

1.  **Application is made for 2.5% vendor preference for the reason checked:**  
Bidder is an individual resident vendor and has resided continuously in West Virginia for four (4) years immediately preceding the date of this certification; or,  
 Bidder is a partnership, association or corporation resident vendor and has maintained its headquarters or principal place of business continuously in West Virginia for four (4) years immediately preceding the date of this certification;  
 Bidder is a resident vendor partnership, association, or corporation with at least eighty percent of ownership interest of bidder held by another entity that meets the applicable four year residency requirement; or,  
 Bidder is a nonresident vendor which has an affiliate or subsidiary which employs a minimum of one hundred state residents and which has maintained its headquarters or principal place of business within West Virginia continuously for the four (4) years immediately preceding the date of this certification; or,
2.  **Application is made for 2.5% vendor preference for the reason checked:**  
Bidder is a resident vendor who certifies that, during the life of the contract, on average at least 75% of the employees working on the project being bid are residents of West Virginia who have resided in the state continuously for the two years immediately preceding submission of this bid; or,
3.  **Application is made for 2.5% vendor preference for the reason checked:**  
Bidder is a nonresident vendor that employs a minimum of one hundred state residents, or a nonresident vendor which has an affiliate or subsidiary which maintains its headquarters or principal place of business within West Virginia and employs a minimum of one hundred state residents, and for purposes of producing or distributing the commodities or completing the project which is the subject of the bidder's bid and continuously over the entire term of the project, on average at least seventy-five percent of the bidder's employees or the bidder's affiliate's or subsidiary's employees are residents of West Virginia who have resided in the state continuously for the two immediately preceding years and the vendor's bid; or,
4.  **Application is made for 5% vendor preference for the reason checked:**  
Bidder meets either the requirement of both subdivisions (1) and (2) or subdivision (1) and (3) as stated above; or,
5.  **Application is made for 3.5% vendor preference who is a veteran for the reason checked:**  
Bidder is an individual resident vendor who is a veteran of the United States armed forces, the reserves or the National Guard and has resided in West Virginia continuously for the four years immediately preceding the date on which the bid is submitted; or,
6.  **Application is made for 3.5% vendor preference who is a veteran for the reason checked:**  
Bidder is a resident vendor who is a veteran of the United States armed forces, the reserves or the National Guard, if, for purposes of producing or distributing the commodities or completing the project which is the subject of the vendor's bid and continuously over the entire term of the project, on average at least seventy-five percent of the vendor's employees are residents of West Virginia who have resided in the state continuously for the two immediately preceding years.
7.  **Application is made for preference as a non-resident small, women- and minority-owned business, in accordance with West Virginia Code §5A-3-59 and West Virginia Code of State Rules.**  
Bidder has been or expects to be approved prior to contract award by the Purchasing Division as a certified small, women- and minority-owned business.

Bidder understands if the Secretary of Revenue determines that a Bidder receiving preference has failed to continue to meet the requirements for such preference, the Secretary may order the Director of Purchasing to: (a) rescind the contract or purchase order; or (b) assess a penalty against such Bidder in an amount not to exceed 5% of the bid amount and that such penalty will be paid to the contracting agency or deducted from any unpaid balance on the contract or purchase order.

By submission of this certificate, Bidder agrees to disclose any reasonably requested information to the Purchasing Division and authorizes the Department of Revenue to disclose to the Director of Purchasing appropriate information verifying that Bidder has paid the required business taxes, provided that such information does not contain the amounts of taxes paid nor any other information deemed by the Tax Commissioner to be confidential.

**Bidder hereby certifies that this certificate is true and accurate in all respects; and that if a contract is issued to Bidder and if anything contained within this certificate changes during the term of the contract, Bidder will notify the Purchasing Division in writing immediately.**

Bidder: West Virginia Tractor Company

Signed: 

Date: 6-1-2016

Title: President

STATE OF WEST VIRGINIA  
Purchasing Division  
**PURCHASING AFFIDAVIT**

**MANDATE:** Under W. Va. Code §5A-3-10a, no contract or renewal of any contract may be awarded by the state or any of its political subdivisions to any vendor or prospective vendor when the vendor or prospective vendor or a related party to the vendor or prospective vendor is a debtor and: (1) the debt owed is an amount greater than one thousand dollars in the aggregate; or (2) the debtor is in employer default.

**EXCEPTION:** The prohibition listed above does not apply where a vendor has contested any tax administered pursuant to chapter eleven of the W. Va. Code, workers' compensation premium, permit fee or environmental fee or assessment and the matter has not become final or where the vendor has entered into a payment plan or agreement and the vendor is not in default of any of the provisions of such plan or agreement.

**DEFINITIONS:**

**"Debt"** means any assessment, premium, penalty, fine, tax or other amount of money owed to the state or any of its political subdivisions because of a judgment, fine, permit violation, license assessment, defaulted workers' compensation premium, penalty or other assessment presently delinquent or due and required to be paid to the state or any of its political subdivisions, including any interest or additional penalties accrued thereon.

**"Employer default"** means having an outstanding balance or liability to the old fund or to the uninsured employers' fund or being in policy default, as defined in W. Va. Code § 23-2c-2, failure to maintain mandatory workers' compensation coverage, or failure to fully meet its obligations as a workers' compensation self-insured employer. An employer is not in employer default if it has entered into a repayment agreement with the Insurance Commissioner and remains in compliance with the obligations under the repayment agreement.

**"Related party"** means a party, whether an individual, corporation, partnership, association, limited liability company or any other form or business association or other entity whatsoever, related to any vendor by blood, marriage, ownership or contract through which the party has a relationship of ownership or other interest with the vendor so that the party will actually or by effect receive or control a portion of the benefit, profit or other consideration from performance of a vendor contract with the party receiving an amount that meets or exceeds five percent of the total contract amount.

**AFFIRMATION:** By signing this form, the vendor's authorized signer affirms and acknowledges under penalty of law for false swearing (W. Va. Code §61-5-3) that neither vendor nor any related party owe a debt as defined above and that neither vendor nor any related party are in employer default as defined above, unless the debt or employer default is permitted under the exception above.

**WITNESS THE FOLLOWING SIGNATURE:**

Vendor's Name: West Virginia Tractor Company

Authorized Signature: *Grasped Ray* Date: 6-1-2016

State of West Virginia

County of Kanawha, to-wit:

Taken, subscribed, and sworn to before me this 1 day of June, 2016

My Commission expires 8/12/2022, 20  

AFFIX SEAL HERE

NOTARY PUBLIC

*Steven B. Basham*

Purchasing Affidavit (Revised 03/01/2015)

