



Purchasing Division
 2019 Washington Street East
 Post Office Box 50130
 Charleston, WV 25305-0130

State of West Virginia
 Request for Quotation

Proc Folder: 35041

Doc Description: Tandem Tractor

Proc Type: Central Purchase Order

Date Issued	Solicitation Closes	Solicitation No	Version
2014-09-23	2014-10-23 13:30:00	CRFQ 1400 AGR1500000004	1

BID RECEIVING LOCATION

BID CLERK

DEPARTMENT OF ADMINISTRATION

PURCHASING DIVISION

2019 WASHINGTON ST E

CHARLESTON

WV 25305

US

VENDOR

Vendor Name, Address and Telephone Number:

Worldwide Equipment Inc.

Lewis County Industrial Park

Jare Lew WV 26378

304-884-7815

or 800-879-3039

10/22/14 09:44:27AM

West Virginia Purchasing Division

FOR INFORMATION CONTACT THE BUYER

Dean Wingerd

(304) 558-0468

dean.c.wingerd@wv.gov

Signature X

FEIN #

45-1024981

DATE

10/21/14

All offers subject to all terms and conditions contained in this solicitation

INVOICE TO		SHIP TO	
PROCUREMENT OFFICER 304-558-2221 AGRICULTURE DEPARTMENT OF ADMINISTRATIVE SERVICES 1900 KANAWHA BLVD E CHARLESTON WV25305-0173 US		AUTHORIZED RECEIVER 304-558-0573 AGRICULTURE DEPARTMENT OF FOOD DISTRIBUTION PROGRAM 4496 CEDAR LAKES RD RIPLEY WV 25271 US	

Line	Comm Ln Desc	Qty	Unit Issue	Unit Price	Total Price
1	Tandem Tractor	1.00000	EA	\$ 107,159	\$ 107,159

Comm Code	Manufacturer	Specification	Model #
25102100	Mack	✓	CXU613

Extended Description :

**THE WEST VIRGINIA PURCHASING DIVISION FOR THE AGENCY, DEPARTMENT OF AGRICULTURE, IS SOLICITING BIDS FOR THE ONE-TIME PURCHASE OF A MODEL YEAR 2015 CLASS 8 DAY CAB TANDEM TRACTOR, FOR THE FOOD DISTRIBUTION PROGRAM, PER THE ATTACHED SPECIFICATIONS.

*** LINE NUMBER 1- 2015 Class 8 Day Cab Tandem Tractor for Donated Foods

INVOICE TO		SHIP TO	
PROCUREMENT OFFICER 304-558-2221 AGRICULTURE DEPARTMENT OF ADMINISTRATIVE SERVICES 1900 KANAWHA BLVD E CHARLESTON WV25305-0173 US		AUTHORIZED RECEIVER 304-558-0573 AGRICULTURE DEPARTMENT OF FOOD DISTRIBUTION PROGRAM 4496 CEDAR LAKES RD RIPLEY WV 25271 US	

Line	Comm Ln Desc	Qty	Unit Issue	Unit Price	Total Price
2	Additional Fees	1.00000	EA	—	—

Comm Code	Manufacturer	Specification	Model #
25102100	Mack	✓	CXU613

Extended Description :

Additional Fees (if necessary)

CERTIFICATION AND SIGNATURE PAGE

By signing below, or submitting documentation through wvOASIS, I certify that I have reviewed this Solicitation in its entirety; understand the requirements, terms and conditions, and other information contained herein; that I am submitting this bid, offer or proposal for review and consideration; that I am authorized by the vendor to execute and submit this bid, offer, or proposal, or any documents related thereto on vendor's behalf; that I am authorized to bind the vendor in a contractual relationship; and that to the best of my knowledge, the vendor has properly registered with any State agency that may require registration.

Worldwide Equipment Inc
(Company)

Scott Peter Scott Peter Director of Government & Municipal Sales
(Authorized Signature) (Representative Name, Title)

800-879-3039 / 859-253-4639 10/21/14
(Phone Number) (Fax Number) (Date)

SPECIFICATIONS

- ✓ 1. **PURPOSE AND SCOPE:** The West Virginia Purchasing Division is soliciting bids on behalf of WV Department of Agriculture to establish a contract for the one time purchase of a 2015 or newer Class 8 Day Cab Tandem Tractor.
- ✓ 2. **DEFINITIONS:** The terms listed below shall have the meanings assigned to them below. Additional definitions can be found in section 2 of the General Terms and Conditions.

- ✓ 2.1 **"Contract Item"** means 2015 or newer Class 8 Day Cab Tandem Tractor. *2016 Mack CXU613*
- ✓ 2.2 **"Pricing Page"** means the pages upon which Vendor should list its proposed price for the Contract Items in the manner requested. The Pricing Page is either included on the last page of this RFQ or attached hereto as Exhibit A. Vendors may also submit bids using the VSS/WV Oasis website and insert pricing on the commodity lines.
- ✓ 2.3 **"RFQ"** means the official request for quotation published by the Purchasing Division.

3. GENERAL REQUIREMENTS:

- ✓ 3.1 **Mandatory Contract Item Requirements:** Contract Item must meet or exceed the mandatory requirements listed below.

✓ 3.1.1 **2015 or newer class 8 Day Cab Tandem Tractor** *2016 Mack CXU613*

✓ 3.1.1.1 Wheelbase must accommodate a 48 foot reefer trailer.

✓ 3.1.1.2 Engine must be compatible with Cummins ISx15 or Detroit DD15 or equal, minimum HP 450 to maximum HP 500, Jaccobs engine brake or equivalent. **No Exhaust Engine Brake**, Engine Block heater 1500 watts-min, exhaust single vertical stainless steel from motor with guard. *MACK MP 8 - 505C 505 HP*

✓ 3.1.1.3 Transmission must be 13 speeds or equivalent. *1760 lb AT torque*

✓ 3.1.1.4 Cab Interior and Exterior must have Air conditioner with heat and filter.

-
- ✓ 3.1.1.5 Full gauge package, Power windows both sides, Mirrors—remote controlled with built in convex and heated, minimum 10 inch convex mounted on LH & RH front fender or hood.
 - ✓ 3.1.1.6 Radio—AM-FM-CD and blue tooth, prewired for CB Radio including dual mounted antenna's on mirrors.
 - ~~✓ 3.1.1.7 Driver seat Bosron high profile (910 or BATH) or equal, no air seat on passenger side.~~
 - ✓ 3.1.1.8 Sun visor—Interior both sides padded.
 - ✓ 3.1.1.9 Power steering, Tilt & telescopic steering & smallest steering wheel available for unit with Cruise control.
 - ✓ 3.1.1.10 Anti-sail mud flaps with stainless mounts.
 - ✓ 3.1.1.11 Roof mounted air deflector not to exceed 12.5' total truck height.
 - ✓ 3.1.1.12 Cat walk mounted behind cab, all pigtails spring mounted on back of cab with glad hand mount, 12volt pigtail to charge lift gate on trailer.
 - ✓ 3.1.1.13 Stainless front bumper.
 - ✓ 3.1.1.14 Fuel Tanks must be Minimum 100 gallon LH & 100 gallon RH aluminum. With stainless mounts and straps. *LH 117; RH 93
210 gallons total*
 - ✓ 3.1.1.15 Front Axle must be Minimum 12,000 pound capacity. Step back for tight turning springs: Flat leaf or taper leaf.
 - ✓ 3.1.1.16 Rear Axle must be Minimum 40,000 pound capacity Tandem with driver controlled differential lock suspension: air ride with inside cab mount dump valve. Geared to maintain 70 MPH at 300-RPM below governor on engine.

-
- ✓ 3.1.1.17 Tires & Wheels must be 11R22.5 Steer & 11R22.5 all season on rear (no low profile) 16 ply.
 - ✓ 3.1.1.18 Wheels: Alloy.
 - ✓ 3.1.1.19 Brakes must be "S" cam brakes with auto adjusters, Air dryer: Bendix "system guard" AD-9 or equal.
-
- ✓ 3.1.1.20 Electrical must be Aluminum. Battery box & covers—12volt system.
 - ✓ 3.1.1.21 Fifth Wheel must be Fontain no-slack II, C7000 series with air slide 24 inch travel or equal.
 - ✓ 3.1.1.22 Warranty must be 3 year bumper to bumper.

4. CONTRACT AWARD:

✓ 4.1 **Contract Award:** The Contract is intended to provide Agencies with a purchase price for the Contract Items. The Contract shall be awarded to the Vendor that provides the Contract Items meeting the required specifications for the lowest overall total cost as shown on the Pricing Pages or on the commodity lines if bid electronically via the VSS system.

✓ 4.2 **Pricing Page:** Vendor should complete the Pricing Page by listing the equipment make, model and cost along with any additional equipment fees. Vendor should complete the Pricing Page, or commodity lines in full as failure to complete in its entirety may result in Vendor's bid being disqualified.

Notwithstanding the foregoing, the Purchasing Division may correct errors as it deems appropriate.

5. PAYMENT:

✓ 5.1 **Payment:** Vendor shall accept payment in accordance with the payment procedures of the State of West Virginia.

6. DELIVERY AND RETURN:

✓ **6.1 Shipment and Delivery:** Vendor shall ship the Contract Items immediately after being awarded this Contract and receiving a purchase order. Vendor shall deliver the Contract Items within 180 Days working days after receiving the purchase order. Contract Items must be delivered to Agency at 4496 Cedar Lakes Road, Ripley, WV 25271.

✓ **6.2 Late Delivery:** The Agency placing the order under this Contract must be notified in writing if the shipment of the Contract Items will be delayed for any reason. Any delay in delivery that could cause harm to an Agency will be grounds for cancellation of the Contract, and/or obtaining the Contract Items from a third party.

Any Agency seeking to obtain the Contract Items from a third party under this provision must first obtain approval of the Purchasing Division.

✓ **6.3 Delivery Payment/Risk of Loss:** Vendor shall deliver the Contract Items F.O.B. destination to the Agency's location.

✓ **6.4 Return of Unacceptable Items:** If the Agency deems the Contract Items to be unacceptable, the Contract Items shall be returned to Vendor at Vendor's expense and with no restocking charge. Vendor shall either make arrangements for the return within five (5) days of being notified that items are unacceptable, or permit the Agency to arrange for the return and reimburse Agency for delivery expenses. If the original packaging cannot be utilized for the return, Vendor will supply the Agency with appropriate return packaging upon request. All returns of unacceptable items shall be F.O.B. the Agency's location. The returned product shall either be replaced, or the Agency shall receive a full credit or refund for the purchase price, at the Agency's discretion.

✓ **6.5 Return Due to Agency Error:** Items ordered in error by the Agency will be returned for credit within 30 days of receipt, F.O.B. Vendor's location. Vendor shall not charge a restocking fee if returned products are in a resalable condition. Items shall be deemed to be in a resalable condition if they are unused and in the original packaging. Any restocking fee for items not in a resalable condition shall be the lower of the Vendor's customary restocking fee or 5% of the total invoiced value of the returned items.



CHASSIS SPECIFICATIONS SUMMARY

October 21, 2014

2016 MACK CXU613

REFRIGERATED VAN . . . On Hwy
TRACTOR FOR 5TH WHEEL

Engine	MACK MP8-505C 505HP	Transmission	RTLO-18913A
		Clutch	CL39DC13 EATON
Front Axle	12,000# FXL12	Rear Axle	40,000# MT-40-14X4C Ratio 3.55
Suspension	12,000#	Suspension	40,000# MAXLITE
Tires	Front: 11R22.5 Rear: 11R22.5	Wheels	22.5x8.25 STEEL DISC (10-HOLE) 22.5x8.25 STEEL DISC (10 HOLE)
Ratings	GVW: 52,000# GCW: 80,000#	Fuel Tanks	LH: 117gal RH: 93gal
Fifth Wheel	BRACKET HEIGHT 8.25" FONTAINE SL7LWB SERIES	Sleeper	

PRICING SUMMARY

	<u>List Price</u>
CHASSIS BASE	\$194,066.00
Factory Options	\$11,337.00
Allison Pricing	\$0.00
Freight	\$2,100.00
Less Additional Factory Rebate	
Sales Allowances	
TOTAL FACTORY	\$207,503.00
Locally Installed Options	\$3,775.00
Soft Products/Bulldog Protection Plans	\$0.00
TOTAL FACTORY & LOCAL	\$211,278.00
Less Customer Discount from List	\$103,858.38
SELLING PRICE (Excluding Taxes/Fees/Trade)	\$107,419.62
Less Trade Allowances per New Vehicle	\$0.00
QUOTED PRICE OR TRADE DIFFERENCE	\$107,419.62
Surcharge	\$0.00
Net FRET or Canadian GST Taxes	\$0.00
Tire Tax Credit (Municipal Only)	(\$260.62)
Sales/Usage Taxes	\$0.00
License/Title/Etc.	
Misc Fees not subject to FRET	
ACQUISITION COST (Include Trade if applies)	\$107,159.00
Less Down Payment	
BALANCE DUE Per Unit	\$107,159.00
PRICE (Total Order)	\$107,159.00
BALANCE DUE (Total Order)	\$107,159.00

Total Quantity: 1

Estimated Total Weight: 16,840#

Reference#: AIYE007816A

X _____
Prepared For: **Customer Signature** **Date**
State of West Virginia, Purchasing Division
2019 Washington Street East
Charleston, WV 25305
Phone: 304-558-0468
Fax: --

X _____
Presented By: **Dealer Signature** **Date**
Scott Pekar
Worldwide Equipment Inc.
945 Nandino Drive
Lexington, KY 40511
(800) 879-3039
scott.pekar@thetruckpeople.com
www.thetruckpeople.com



Prepared For:

State of West Virginia Purchasing Division
2019 Washington Street East
Charleston, WV 25305
(304) 558-0468

Presented By:

Worldwide Equipment Inc.
945 Nandino Drive
Lexington, KY 40511
(800) 879-3039
scott.pekar@thetruckpeople.com
www.thetruckpeople.com

Oct 21, 2014
2016 CXU613
Ref#: AIYE007816A

Description

ORDER/CUSTOMER/VEHICLE INFORMATION

INITIAL REGISTRATION LOCATION, UNITED STATES, WEST VIRGINIA Opt
LANGUAGE, ENGLISH Std
IDLE EMISSION CERTIFICATION, IDLE EMISSION CERTIFICATION - CARB 08 Std
TYPE OF SERVICE, MUNICIPAL Opt
VEHICLE APPLICATION CLASS, ON-HIGHWAY CLASS "A" - Unlimited operation on concrete, asphalt, or maintained gravel/packed dirt with a maximum 3% grade; limited operation on concrete, asphalt, or maintained gravel/packed dirt with maximum 8% grade. No operation on unmaintained surfaces. (3 AXLES) 64,000 lbs (29,030 kg) MAX GVW. (4 AXLES) 80,000 lbs (36,288 kg) MAX GVW. Opt
CARRIER APPLICATION, VENDOR CARRIER Std
VEHICLE TYPE, TRACTOR FOR 5TH WHEEL Std
VEHICLE USE AND BODY/TRAILER TYPE, REFRIGERATED VAN . . On Hwy
80000# (36287 kg) GCW RATING Opt
BRAKE - STOPPING DISTANCE, BRAKE REGULATION, STOPPING DISTANCE 76M (250FT) Std
PRICE BOOK LEVEL, 2016A PRICE BOOK LEVEL Std
PRODUCT TYPE, PRODUCT TYPE - CMM64T TRACTOR Opt
PRODUCT CLASS, PRODUCT CLASS 28 Opt
BACK OFFICE PROCESS, BACK OFFICE PROCESS Std

OPERATING CONDITIONS

TOPOGRAPHY, GRADES <3% GREATER THAN 98% OF DRIVING DISTANCE MAX GRADE 8% Opt
TRANSPORTAION CYCLE, LONG HAUL Opt
ROAD CONDITION, WELL MAINTAINED SURFACED ROADS >95% DRIVING DISTANCE Opt
AMBIENT TEMPERATURE UPPER LIMIT, AMBIENT TEMPERATURE HOT. WARMER THAN 104 F (40 C) ALLOWED UP TO 25 HOURS PER YEAR Opt

BVS/FRT AXLE POS/SALES PACKAGES

CHASSIS (BASE MODEL), CXU603 6-WHEEL TRACTOR Std

ENGINE/TRANSMISSION/CLUTCH

SUPER ECONODYNE PACKAGE, W/O SUPER ECONODYNE PACKAGE Std
ENGINE, MACK MP8-505C 505 HP @1500-1700 RPM (PEAK) 1760 LB FT. MAX TORQUE @ 1100-1400 RPM Opt
TRANSMISSION, 13 SPEED MANUAL, FULLER RTLO-18913A (12.31/0.73) Opt
CLUTCH, MANUAL ADJUSTING, CL39DC13 EATON ADVANTAGE EZ-PEDAL, 9-SPRING, 2-PLATE, 15.5" CERAMIC CLUTCH, 6 PADDLES, MANUAL ADJ Opt

EXHAUST/EMISSIONS

DPF, CLEARTECH HHS DPF RH SIDE UNDER CAB W/SCR FRAME MTD RH SIDE Std
EXHAUST AFTER-TREATMENT SYSTEM, EXHAUST AFTER-TREATMENT SYSTEM DIESEL PARTIC FILTER CERAMIC PASSIVE REGEN Std
DPF SMART SWITCH, NO INHIBIT DPF REGENERATION SWITCH Std
EXHAUST, DPF, OUTBOARD, SINGLE (R/S) VERTICAL STRAIGHT EXHAUST STACK TURNED OUT Std
FURNISH STEEL PAINTED HEAT SHIELD FOR FRAME MTD MACK CAP DPF Std

ENGINE EQUIPMENT

AIR COMPRESSOR, MERITOR/WABCO 318 18.7 CFM Std
ALTERNATOR, DELCO 12V 130A (24SI) BRUSH-TYPE Std
BATTERIES, (3) MACK 12V 650/1950 CCA THREADED STUD TYPE W/KALAS CABLES Std
TO -34 DEGREES F (-37 DEGREES C) Std

Description	
MACK COOLANT CONDITIONER	Std
EMERGENCY ENGINE STOP, WITHOUT EMERGENCY STOP	Std
ENGINE BRAKE, MACK POWERLEASH	Opt
ENGINE BLOCK HEATER, 120V 1500 WATT ENGINE BLOCK HEATER	Opt
FAN DRIVE, BEHR FAN WITH BEHR ELECTRONICALLY MODULATED FAN DRIVE	Opt
FLYWHEEL HOUSING, ALUMINUM	Std
FUEL-WATER SEPARATOR, MACK W/MANUAL DRAIN VALVE (INTEGRAL W/PRIMARY FUEL FILTER)	Std
HOSES - RADIATOR/HEATER, MACK BRAND EPDM RADIATOR & HEATER HOSES	Std
OIL PAN, OIL PAN	Std
OIL PAN HEATER, W/O OIL PAN HEATER	Std
STARTER, 12 VOLT DELCO 39MT-MXT	Std
TETHER DEVICE, FURNISH CAP RETAINER FOR OIL FILL & RADIATOR OVERFLOW TANK	Std
LOADSENSE, W/O LOADSENSE TORQUE LIMITATION	Std
TRANSMISSION EQUIPMENT/DRIVELINES	
CLUTCH ASSIST (AIR), MECHANICAL CABLE	Opt
CLUTCH PEDAL, CLUTCH PEDAL RUBBER PAD	Opt
TRANSMISSION SHIFT SETTINGS, W/O TRANSMISSION SHIFT SETTINGS	Opt
TRANSMISSION PTO1 SPLITTER RANGE, W/O PTO1 FOR SPLITTER RANGE	Opt
TRANSMISSION PTO2 SPLITTER RANGE, W/O PTO2 SPLITTER RANGE	Opt
TRANSMISSION BELL HOUSING, IRON	Opt
WITHOUT TRANSMISSION OIL COOLER	Std
SYNTHETIC LUBRICANT - TRANSMISSION, 50W (SYNTHETIC LUBRICANT)	Opt
VOCATIONAL PACKAGE - ALLISON, W/O OPTIONAL ELECTRONIC TRANS PACKAGE	Std
DRIVELINE - MAIN, MERITOR 18 MXL "XTENDED LUBE"	Opt
DRIVELINE - INTERAXLE, MERITOR 17 MXL "XTENDED LUBE"	Opt
AERODYNAMIC DEVICES	
ROOF FAIRINGS/SIDE SHIELDS, ROOF FAIRING, BRACKETRY/FIBERGLASS FAIRING PIECES INCLUDED (ROOF PIECES NOT INSTALLED)	Opt
CHASSIS FAIRINGS, WITHOUT CHASSIS FAIRINGS	Std
GROUND EFFECTS, WITHOUT GROUND EFFECTS	Std
CAB (A thru G)	
MACK INTEGRAL W/HEATER (COMBO HEATER/AIR CONDITIONER UNIT) W/R134a REFRIGERANT	Std
AIR RESTRICTION MONITOR (INTAKE), W/O AIR RESTRICTION MONITOR	Std
CAB, LH-STEER CA68 CONV CAB	Std
CERTIFIED WEIGHT	Std
PARK BRAKE AND ENGINE RUNNING ACTIVATED	Std
(4) DOME LAMPS - DOOR AND SWITCH ACTIVATED	Std
VISIBILITY DOOR	Std
GAUGE CLUSTER, EXHAUST PRYOMETER AND TRANSMISSION OIL TEMPERATURE GAUGES	Std
GAUGES, ENGLISH/METRIC DISPLAY	Std
WITHOUT REAR AXLE OIL TEMPERATURE GAUGE	Std
GEAR SHIFT, W/O OPTIONAL GEAR SHIFTER	Opt
GLASS - CAB WINDOW, TINTED WINDSHIELD, SIDE AND REAR WINDOWS	Std
GRAB HANDLES, BRIGHT FINISH GRAB HANDLES IN LIEU OF BLACK ON CAB EXTERIOR	Opt
CAB (H thru R)	
HEADLINER, VINYL COVERED FOAM PADDED HEADLINER	Opt

Description

HOOD INSULATION	Std
PAINTED HOOD LATCHES	Std
HORN - AIR, (1) BLACK TWIN TRUMPET	Inc
HORN - ELECTRIC, SINGLE TONE	Std
IDENTIFICATION/CLEARANCE LIGHTS, (5) MARKER AND CLEARANCE, INCANDESCENT, FLUSH MOUNTED	Inc
IN-DASH STORAGE, W/O UPPER STORAGE OPTION	Std
INSTRUMENT CLUSTER DISPLAY, CO-PILOT DRIVER DISPLAY, ENHANCED 4.5" DIAGONAL LCD DISPLAY W/4-BUTTON STALK CONTROL	Std
INTERIOR TRIM (CUSTOM - SLATE GRAY) 3 overhead storage compartments w/nets, rear panel storage pouch w/2 trash bag hooks, diamond pattern fabric on doors vinyl padded interior sun visor both sides, adjustable tilt/telescoping steering column, 2 overhead dome lights, 1 driver overhead spot light & 1 map non-glare overhead spot light, 2 12V power outlets, 2 cup holders, 2 coat hangers, RH center storage compartment, both door MTD storage pouches, lighted door MTD, map pocket lights.	Opt
CHASSIS KEYPED AT RANDOM - 2 KEYS	Std
MIRRORS - EXTERIOR, AERO MIRROR, BODY COLORED, RH & LH HEATED AND MOTORIZED WITH INTEGRATED CONVEX MIRROR	Opt
MIRRORS - CONVEX TYPE HOOD/FENDER, ROUND BRIGHT FINISH FENDER MTD W/SS ARMS AND BRACKETS R.H. & L.H.	Opt
MIRRORS - CONVEX TYPE CAB DOORS, WITH AERO MIRRORS	Std
OVERHEAD CONSOLE, (2) STORAGE COMPARTMENTS W/NET	Inc
AM/FM PREMIUM STEREO, CD-PLAYER, MP3, WEATHERBAND, HANDSFREE INTERFACE, BLUETOOTH	Std
48" ANTENNA RIGHT SIDE MIRROR MOUNTED	Std
PROVIDE MOUNTING PLATE AND VELCRO STRAP IN HEADER CONSOLE	Opt
CAB (S thru Z)	
SEAT - DRIVER, BOSTROM TALLADEGA 915 (MID-BACK) AIR SUSPENSION	Inc
SEAT - RIDER, MACK FIXED (MID-BACK) NON-SUSPENSION	Inc
SEAT COVERING, CLOTH W/VINYL TRIM DRIVER AND RIDER	Inc
SEAT BELTS, LAP AND SHOULDER W/CAB MOUNTED SHOULDER BELT WITH FIXED D-RING FOR DRIVER AND RIDER SEATS	Std
STEERING COLUMN, ADJUSTABLE TILT TELESCOPE	Std
STEERING WHEEL, TWO SPOKE URETHANE GRIP BRUSHED NICKEL SPOKES, BRUSHED CHROME MACK HORN CAP	Inc
STORAGE POUCH REAR	Std
SUN VISOR - INTERIOR, BOTH SIDES (PADDED VINYL) WITH TICKET HOLDER	Std
TURN SIGNAL SWITCH, MANUAL CANCELLING TURN SIGNALS	Std
WINDOW CONTROLS, POWER WINDOW LIFT WITH ELECTRIC DOOR LOCK, LH & RH	Opt
WINDSHIELD, 2-PIECE WINDSHIELD	Std
CAB - SLEEPER BOX	
COMMUNICATIONS SYSTEMS	
GUARDDOG CONNECT W/3G AND WLAN SYSTEM W/DIAGNOSTIC	Std
FRAME EQUIPMENT/FUEL TANKS	
BUMPER - FRONT, STAINLESS STEEL CLAD ALUMINUM FLUSH MTD 117.3"/2980 mm BBC (CORPORATE 94" x 15.5")	Opt
CROSSMEMBERS, STEEL	Std
BOXED AND TAPERED CROSSMEMBER	Std
FIFTH WHEEL, AIR SLIDE - LH RELEASE (BOLTED TO OUTBOARD MTG ANGLES), FONTAINE SL7LWB SERIES, BRACKET HEIGHT 8.25"	Opt

Description

5TH WHEEL MOUNTING ANGLES, OUTBOARD MOUNTED ANGLES WITH MOUNTING HOLES	Std
FLAPS - WHEEL (FRONT), BLACK SPRAYGUARD ANTI-SPRAY TYPE	Opt
FLAPS - MUD (REAR), MACK BULLDOG TYPE, WHITE ANTI-SPRAY TYPE	Opt
MUD FLAP BRACKETS, BETTS B60S (ANGLED) STAINLESS STEEL W/INTEGRATED REFLECTIVE TAPE	Opt
QUARTER FENDERS, STAINLESS STEEL QUARTER FENDERS	Opt
TOWING DEVICE - FRONT, (2) CLEVIS	Std
TOWING DEVICE - REAR, W/O REAR TOWING DEVICE	Std
W/O REAR TOWING DEVICE	Std
FUEL TANK - LH, 117 GALLON (442 L) 26" ALUMINUM ROUND	Opt
FUEL TANK - RH, 93 GALLON (350L) 26" ALUMINUM ROUND	Opt
BRIGHT FINISH ALUMINUM STEPS & STAINLESS STEEL BRIGHT FINISHED STRAPS	Opt
18.4 GALLON (70 L) 26" DIAMETER TANK LEFT SIDE FRAME MTD	Std
PAINTED FINISH DEF TANK COVER	Std
NYLON TUBE	Std
DUAL DRAW AND RETURN FUEL SYSTEM	Std
FRONT AXLE/EQUIPMENT/TIRES	
FRONT AXLE, 12000# (5443kg) MACK FXL12 STRAIGHT SPINDLE/UNITIZED BEARINGS	Std
TIRES BRAND/TYPE - FRONT, BRIDGESTONE - TUBELESS RADIAL PLY, (2) 11R22.5 16 H R268 ECOPIA (ALL POSITION)	Opt
WHEELS - FRONT, STEEL DISC (10-HOLE)	Opt
(2) 22.5x8.25 HAYES LEMMERZ 10-HOLE HUB PILOTED (11 1/4"/286mm BC) (TWO HAND HOLE)	Opt
BRAKES - FRONT, BENDIX ES165-05D, 16.5" x 5" CAST SPIDER	Std
BRAKE DRUMS - FRONT, CAST OUTBOARD MOUNTED	Std
DUST SHIELDS - FRONT BRAKE, OMIT	Std
HUBS - FRONT, FERROUS	Opt
FAG SCHAEFFLER, FRONT GREASE SEAL	Std
DOUBLE ACTING TYPE	Std
SLACK ADJUSTERS - FRONT, MERITOR - AUTOMATIC	Opt
SPRINGS - FRONT, MACK TAPERLEAF HD 12000# (5443kg) GROUND LOAD RATING (2 LEAF SPRING)	Std
STEERING, TAS-65 TRW INTEGRAL POWER	Std
SYNTHETIC LUBRICANT - WHL BEARINGS, FACTORY OPTION FRONT WHEEL BEARINGS LUBRICANT	Std
REAR AXLE/EQUIPMENT/TIRES/RATIOS	
REAR AXLE/SUSPENSION, 40000# (18144kg) MERITOR MT-40-14X4C AMBOID (HIGH ENTRY), MT-40-14XC WITH MAXLITE 40 EZ (GEN 2) 40000#	Std
TIRES BRAND/TYPE - REAR, BRIDGESTONE - TUBELESS RADIAL PLY, (8) 11R22.5 14 G M726EL (TRACTION)	Opt
CARRIER/RATIO - REAR AXLE, MALLEABLE HOUSING, 3.55 RATIO	Opt
WHEELS - REAR, STEEL DISC (10 HOLE)	Opt
(8) 22.5x8.25 HAYES LEMMERZ 10-HOLE HUB PILOTED (11 1/4"/286 mm BC)(TWO HAND HOLE)	Opt
BRAKES - REAR, BENDIX ES165-07L, 16.5x7 STAMPED SPIDER	Std
BRAKE DRUMS - REAR, CAST OUTBOARD MOUNTED	Std
DUST SHIELDS - REAR BRAKE, OMIT	Std
HUBS - REAR, CONMET IRON HUBS W/PRESET BEARINGS & SEALS	Opt
PREMIUM HUB OIL REAR SEAL	Std
POWER DIVIDER LOCKOUT	Std
SHOCK ABSORBERS - (4), MOUNTED ON FORWARD AND REAR AXLES EACH SIDE	Inc
W/O SHOCK INSULATORS	Std

Description

SLACK ADJUSTERS - REAR, MERITOR - AUTOMATIC	Opt
SUSPENSION - AXLE SPACING, 52" AXLE SPACING (BOGIE WHEELBASE)	Std
SUSPENSION - HEIGHT CONTROL KIT, AIR SUSPENSION HEIGHT CONTROL KIT (W/DUMP VALVE AND CONTROL)	Std
AIR SUSPENSION DUMP WARNING, AIR SUSPENSION DUMP, SPEED LIMITED, WARNING INDICATOR & BUZZER	Std
SPRING BRAKE CHAMBERS - VENDOR, HALDEX "LIFE SEAL" TYPE	Opt
REAR SPRING BRAKE CHAMBERS 30/30 TYPE	Std
LUBRICANT - TANDEM REAR AXLE, 75W - 90 (SYNTHETIC LUBRICANT) - SYNTHETIC	Opt
TRANSVERSE TORQUE RODS (BOTH AXLES)	Inc
DRIVER CONTROLLED INTER WHEEL DIFFERENTIAL LOCK FRT RR AXLE, MANUAL AIR VALVE W/WARNING LIGHT.	Opt
FRAME/WHEELBASE/PLATFORM	
WHEELBASE, 197" (5010 mm) WB 132" CA (3347 mm)	Opt
PLATFORM, 194" LP (4927 mm) 62" AF (1580 mm) USED WITH 197" WB	Opt
FRAME RAILS, 10.47" x 3.54" x .28" (266 x 90 x 7mm) STEEL Section Modulus: 13.3 cu in/RBM 1,600,000 in lbs per rail	Opt
AIR/BRAKE	
AIR DRYER, MERITOR/WABCO HEATED AIR DRYER, 1200 W/COALESCING OIL FILTER	Std
ANTI-LOCK BRAKE SYSTEM, MACK ROAD STABILITY ADVANTAGE BENDIX ABS/ATC/ESP W/YAW CONTROL	Std
ATC DISABLE SWITCH, W/O AUTOMATIC TRACTION CONTROL (ATC) DISABLE SWITCH	Std
W/O COLLISION WARNING SYSTEM	Std
WITHOUT ACB VOLUME LEVEL	Std
BRAKE CONTROL VALVE SYSTEM, TWO (2) VALVE DUAL BRAKE SYSTEM - TRAILER SUPPLY AND TRACTOR-TRAILER PARK	Std
DRAIN VALVES, MANUAL DRAIN VALVES, WITH LANYARD ON SUPPLY TANK ONLY	Std
HAND CONTROL VALVE FOR TRAILER BRAKES	Std
WITHOUT SPRING BRAKE INVERSION VALVE	Std
LOW PROFILE DECK PLATE (Useable CA, 112"-129")	Opt
TRAILER CONNECTIONS	
TRAILER AIR CONNECTIONS, TRAILER AIR BRAKE CONNECTIONS, BACK OF CAB	Std
TRAILER AIR HOSES (12 FT NON-COILED TYPE)	Std
GLAD HAND COUPLINGS - NORTH AMERICAN STD	Std
TRAILER ELECTRICAL CORD (12 FT NON-COILED TYPE)	Std
ELECTRICAL	
BATTERY BOX COVERS, POLISHED ALUMINUM	Opt
BATTERY BOX - MOUNTING, (4) BATTERY MAX, MTD LHS LOWER UNDER CAB, PARALLEL TO FRAME W/STEPS AND W/AIR RESVR. MTD BELOW	Std
CHASSIS & POWER HARNESS WITH STANDARD CASING	Std
TRIPLES TRAILER ELECTRICAL PACKAGE INCLUDES: 12 GAUGE WIRE FOR TURN SIGNALS, 12 GAUGE WIRE AND 30 AMP CIRCUIT W/RELAY FOR CLEARANCE AND MARKER LAMPS, 10 GAUGE WIRE AND 20 AMP CIRCUIT W/RELAY FOR STOP LAMPS, 12 GAUGE WIRE AND 20 AMP CIRCUIT W/RELAY FOR TAIL LAMPS, AND 8 GAUGE WIRE FOR GROUND	Std
ELECTRIC CIRCUIT PROTECTION PACKAGE, ALL CIRCUITS FUSE/BREAKER PROTECTED	Std
WATERPROOF ELECTRICAL CONNECTIONS SPRAYED W/PROTECTIVE COATING	Std
TRAILER HOOK-UP LIGHT, SINGLE, SURFACE MOUNTED, INCANDESCENT	Opt
PAINT/VINYL STRIPING	
PAINT/VINYL STRIPING - CAB EXTERIOR, SINGLE COLOR, MACK WHITE (HIGH GLOSS)	Std
PAINT - CAB, URETHANE BASE COAT W/O CLEAR COAT	Std
PAINT - CHASSIS RUNNING GEAR, MACK BLACK (URETHANE)	Std

Description

PRE-FINISHED POWDER COAT WHITE	Opt
PRE-FINISHED POWDER COAT WHITE	Opt
PAINT PROCESS CODES	
W/O PAINT FOR BUMPER (5ZB-Z1X)	Inc
CHASSIS RUNNING GEAR - STD COLOR (MACK BLACK) (6AB-Z1X)	Inc
W/O PAINT FOR FUEL TANK (7HB-Z1X)	Inc
W/O CUSTOM PAINT FOR HUB&DRUM/SPOKES (5YB-Z1X)	Inc
W/O CUSTOM PAINTED FRONT/REAR RIM/WHEEL (6BB-Z1X)	Inc
PTO/SPECIALTY/ADDITIONAL EQUIPMENT	
W/O OPTIONAL TRANS TORQUE CONVERTER	Std
V-MAC IV PROGRAMMABLE PARAMETERS	
CUSTOMER VEHICLE LIMITING SPEED (MPH) 70 mph	
PEDAL ROAD SPEED LIMITER (MPH) 70 mph	
LGVLS FEATURE ACTIVATION	Omit
LOWER GEAR VEHICLE LIMITING SPEED (MPH) 00 mph	
SOFT RSL	Omit
PDLO ENGAGED VLS FEATURE	Furnish
PDLO ENGAGED VEHICLE LIMITING SPEED 25 rpm	
CRUISE CONTROL SETTINGS W/O ALLISON TRANS	Std
CRUISE CONTROL MAX SET SPEED (MPH) 70 mph	
CRUISE CONTROL MIN SET SPEED (MPH) 20 mph	
CRUISE CONTROL AUTORESUME W/CLUTCH	Furnish
CRUISE'N BRAKE ENGAGEMENT DELAY (MPH) 3 mph	
SMOOTH CRUISE	Omit
ENGINE OVERSPEED COMPANY LIMIT (RPM) 2200 rpm	
FUELED ENGINE OVERSPEED COMPANY LIMIT (RPM) 2100 rpm	
VEHICLE OVERSPEED COMPANY LIMIT (MPH) 75 mph	
FUELED VEHICLE OVERSPEED COMPANY LIMIT (MPH) 70 mph	
IDLE LOGGING DELAY (MIN) 2	
Monthly Trip Summary	
PERIODIC TRIP HOUR OF DAY 0 (disable)	
PERIODIC TRIP DAY OF WEEK 0 (disable)	
PERIODIC TRIP DAY OF MONTH 1	
DAYTIME RUNNING LIGHTS W/O OVERRIDE SWITCH	Std
DRL OVERRIDE SWITCH SPEED THRESHOLD (MPH) 00	
DRL OVERRIDE SWITCH OFF TIME (MIN) 00 mph	
CO-PILOT FLEET TRIP PROGRAMMING ACCESS	Fleet Level
FLEET MANAGEMENT VIA CO-PILOT	Omit
EHT MAX ENGINE SET SPEED (RPM)	
2100 rpm	
EHT MIN ENGINE SET SPEED (RPM) 700 rpm	
EHT VEHICLE SPEED RANGE LIMIT (MPH) 10 mph	
EHT RAMP RATE (RPM/Sec)	
EHT SINGLE SPEED CONTROL ACTIVATION	Omit
EHT SINGLE SPEED CONTROL SET SPEED (RPM) 0000 rpm	
EHT JUMP-TO-MIN SET SPEED	Omit

Description

EHT HOLD TO NEAREST RPM 50 rpm
 EHT ACCEL-DECEL BUMP-UP RPM 50 rpm
 EHT ACCEL-DECEL BUMP-DOWN RPM 50 rpm
 ENGINE PROTECTION - OIL PRESSURE SHUTDOWN Furnish
 ENGINE PROTECTION - COOLANT LEVEL SHUTDOWN Omit
 ENGINE PROTECTION - COOLANT TEMP SHUTDOWN Furnish
 ENGINE PROTECTION - ENGINE OIL TEMP SHUTDOWN Furnish
 ENGINE PROTECTION TRANS OIL TEMP SHUTDOWN Furnish
 ALLOW FAN OVERRIDE WHEN PARKED Omit
 FAN ACTIVATION WITH PTO Omit
 FUEL ECONOMY INCENTIVE FOR USE WITH INSTRUMENT CLUSTER DISPLAY (C0J 0002) Std
 FEI PENALTY TARGET FUEL ECONOMY No Driver Incentive
 FEI PENALTY TARGET FUEL ECONOMY (MPG) 0.0
 FEI PENALTY VEHICLE SPEED DECREASE (MPH) 0 mph
 FEI REWARD TARGET FUEL ECONOMY (MPG) 0.0
 FEI REWARD VEHICLE SPEED INCREASE (MPH) 0 mph
 FEI DISTANCE CALCULATION INTERVAL (Miles) 00
 GOVERNOR SETTINGS FOR USE WITH MANUAL TRANSMISSIONS Inc
 GOVERNOR TYPE Min-Max Governor
 ENGINE HIGH IDLE SPEED IF STOPPED 0000
 VEHICLE ACCELERATION LIMITING FEATURE Disable
 REDUCED ENGINE RPM RANGE IN UPPER GEARS FEATURE Disable
 ENGINE RPM LIMIT IN UPPER GEARS 0000
 1st TRANS RATIO FOR REDUCED HIGH IDLE 0000
 LAST TRANS RATIO FOR FULL HIGH IDLE 0000
 ENGINE LOW IDLE SET SPEED (RPM) 650 rpm
 DRIVER LOW IDLE ADJUST FEATURE ACTIVATION Omit
 SMART IDLE FEATURE ACTIVATION Omit
 SMART IDLE ELEVATED IDLE RPM TIME (MINS) 10
 IDLE S/D ABS TAMPER CHECK Omit
 IDLE COOLDOWN FEATURE ACTIVATION Furnish
 IDLE SHUTDOWN FEATURE ACTIVATION Omit
 IDLE SHUTDOWN TIME (MINS) 10
 IDLE SHUTDOWN WARNING TIME (SECS) 30
 IDLE SHUTDOWN WARM-UP TEMPERATURE (DEG F) 100
 IDLE SHUTDOWN WARM-UP TIMER (MINS) 5
 IDLE S/D OVERRIDE W/EHT Omit
 IDLE S/D OVERRIDE W/PTO Furnish
 IDLE S/D OVERRIDE W/ENGINE LOAD Furnish
 IDLE S/D OVERRIDE % ENGINE LOAD THRESHOLD 20
 IDLE S/D CONTROL W/O Idle Shutdown
 IDLE S/D OVERRIDE LOWER TEMP. THRESHOLD (DEG F) 60
 IDLE S/D OVERRIDE UPPER TEMP. THRESHOLD (DEG F) 80
 MAINTENANCE MONITOR FEATURE ACTIVATION Furnish
 MAINTENANCE MONITOR OEM DEFAULT INTERVALS MP Highway
 MAINTENANCE DUE WARNING PERCENT 90

Description

PTO 1 MAX ENGINE SET SPEED (RPM) 2100 rpm
 PTO 1 MIN ENGINE SET SPEED (RPM) 600 rpm
 PTO 1 VEHICLE SPEED RANGE LIMIT (MPH) 10 mph
 PTO 1 RAMP RATE (RPM/Sec) 100
 PTO 1 SINGLE SPEED CONTROL ACTIVATION Omit
 PTO 1 SINGLE SPEED CONTROL SET SPEED (RPM) 1000 rpm
 PTO 1 SINGLE SPEED CONTROL AUTOSET Omit
 PTO 1 JUMP-TO-MIN SET SPEED Omit
 PTO 1 VEHICLE LIMITING SPEED (MPH) 60 mph
 PTO 1 HOLD TO NEAREST RPM 50 rpm
 PTO 1 ACCEL-DECEL BUMP-UP RPM 50 rpm
 PTO 1 ACCEL-DECEL BUMP-DOWN RPM 50 rpm
 PTO 2 MAX ENGINE SET SPEED (RPM) 2100 rpm
 PTO 2 MIN ENGINE SET SPEED (RPM) 600 rpm
 PTO 2 VEHICLE SPEED RANGE LIMIT (MPH) 10 mph
 PTO 2 RAMP RATE (RPM/Sec) 100
 PTO 2 SINGLE SPEED CONTROL ACTIVATION Omit
 PTO 2 SINGLE SPEED CONTROL SET SPEED (RPM) 1000 rpm
 PTO 2 SINGLE SPEED CONTROL AUTOSET Omit
 PTO 2 JUMP-TO-MIN SET SPEED Omit
 PTO 2 VEHICLE LIMITING SPEED (MPH) 60 mph
 PTO 2 HOLD TO NEAREST RPM 50 rpm
 PTO 2 ACCEL-DECEL BUMP-UP RPM 50 rpm
 PTO 2 ACCEL-DECEL BUMP-DOWN RPM 50 rpm
 SPEED SENSOR TAMPER DETECTION SYSTEM ACTIVATION Furnish
 SPEED SENSOR TAMPER DETECTION TORQUE LIMIT (%) 50
 TIME GAP SETTING, WITHOUT TIME GAP SETTINGS

Std

DEALER INFORMATION

ENGINE WARRANTY, 2YR/250,000 MILES ENGINE WARRANTY US10
 PILOT INSPECTION, WITHOUT PILOT INSPECTION
 PREP FOR DELIVERY
 3 YEAR BUMPER TO BUMPER WARRANTY
 STANDARD SHIPPING INSTRUCTIONS

Std

Opt

Std

SOFT PRODUCTS/BULLDOG PROTECTION

2 YEARS COVERAGE
 NO PARTNERED SERVICES PROVIDED

Std

Std



**WORLDWIDE
EQUIPMENT**

THE TRUCK PEOPLE

**Kenworth
Volvo
Mack
Isuzu**



**Charleston Division
304-744-1321**

General Manager | Matt Cochran

**Huntington Division
304-736-3401**

General Manager | Matt Cochran



**Jane Lew Division
304-884-7815**

General Manager | Greg St. Clair



**Princeton Division
304-425-7511**

General Manager | Randy Terry

SALES - SERVICE - PARTS - LEASING

WWW.THETRUCKPEOPLE.COM



WORLDWIDE EQUIPMENT

COMPANY FACTS

About our Company

WORLDWIDE EQUIPMENT's story begins in 1967. Understanding the need for a heavy-duty truck dealer to successfully serve the coal industry of Eastern Kentucky, **WE** acquired its first MACK® franchise in Prestonsburg, Kentucky. **WE** quickly developed relationships with local businesses and drivers that have now grown for over 40 years. **WE** added the Kenworth, Volvo, Hino, and Isuzu brands to our medium and heavy-duty lines. Over time, **WE** have expanded our locations to full-service dealerships, satellite parts stores and leasing facilities in Tennessee, Kentucky, South Carolina, Ohio, Virginia, and West Virginia.

Our history assures you that you can depend on us to be here to provide the products and services you need for as long as you own your trucks. Our strong financial position, large coverage area, and experienced personnel allow us to provide very competitive pricing and premium services not readily available from other dealerships.

Stop by one of our locations today to see how **WORLDWIDE EQUIPMENT** is changing the trucking industry.

Quick Facts

- Established **1967**
- President, CEO: Terry Dotson
- Over **900** employees
- Trucks - Mack, Volvo, Kenworth, Hino, Isuzu | Trailers - East, Featherlite, Dorsey, Dynaweld
- **36** Locations: **16** full-service dealerships | **5** parts locations | **15** leasing offices | **1** full-detail shop | **1** fabrication facility
- Along major Interstates: I-81, I-40, I-64, I-79, I-24, I-75, I-77, I-26, I-85



SALES

New & Used Truck & Trailer
Mack
Volvo
Kenworth
Hino
Isuzu
Dorsey
East
Featherlite
Dynaweld



PARTS

Truck & Trailer Parts
Private Label Parts Brand:
Road Champion
An average of \$20 million
continuously stocked parts
in inventory



SERVICE

Truck & Trailer Parts
Over 250 Full-Service Bays
Heavy-Duty Diesel Service
Certifications:
CAT, Cummins, GMC



FINANCING & INSURANCE



LEASING & RENTAL

Medium & Heavy Duty
Long-term leasing
Short-term rental

SPECIALTY SERVICE

Body & Detail Shop
Collision Repair
Frame & Alignment work
Fabrication
Manufacturing
CT Tank Inspection & Repair
Crane Inspection



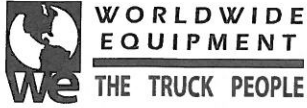

Directory

KENTUCKY

SALES / SERVICE

LEXINGTON
859-281-5152
945 Nardino Drive
Lexington, KY 40511



MIDDLESBORO
606-248-5100
Mack Avenue, Industrial Park
Middlesboro, KY 40965



PRESTONSBURG
606-874-2172
107 We Drive
Prestonsburg, KY 41653



SOMERSET
606-679-4321
208 Industry Road
Somerset, KY 42501



LEASING

LEXINGTON
859-233-3740
1677 Jaggie Fox Way
Lexington, KY 40511

ASHLAND
606-928-1129
1026 US Route 60
Ashland, KY 41102

BETSY LAYNE
606-478-9552
155 KY Oil Village
Betsy Layne, KY 41605

LONDON
606-878-1418
252 South Barbourville Road
London, KY 40744

SOMERSET
606-274-4020
4001 Old Barnesburg Road
Somerset, KY 42501

PARTS ONLY

LONDON
606-877-3012
1210 Mardis Street
London, KY 40741

PIKEVILLE
606-437-0130
1188 South Mayo Trail
Pikeville, KY 41501

SPECIALTY

Worldwide Fabrication
606-297-1200
85 August Circle
Lowmansville, KY 41232

OHIO

SALES / SERVICE

CINCINNATI
513-563-6363
10649 Evendale Drive
Cincinnati, OH 45241



DAYTON
937-278-5775
5750 Poe Avenue
Dayton, OH 45414



LEASING

CINCINNATI
513-577-8001
10649 Evendale Drive
Cincinnati, OH 45241

SOUTH CAROLINA

SALES / SERVICE

CHARLESTON
843-725-5378
2755 Azalea Drive
North Charleston, SC 29405



COLUMBIA
803-926-2900
707 Cherokee Lane
West Columbia, SC 29169



GREENVILLE
864-220-3033
2727 White Horse Road
Greenville, SC 29611



LEASING

CHARLESTON
843-725-5358
2755 Azalea Drive
North Charleston, SC 29405

COLUMBIA
803-926-2900
707 Cherokee Lane
West Columbia, SC 29169

GREENVILLE
864-220-2509
1055 Park West Blvd.
Greenville, SC 29611

TENNESSEE

SALES / SERVICE

CHATTANOOGA
423-698-4093
2017 East 23rd Street
Chattanooga, TN 37404



KNOXVILLE
865-688-4300
6614 Wilbanks Road
Knoxville, TN 37912



LEASING

KNOXVILLE
865-637-4341
6416 Asheville Highway
Knoxville, TN 37914

JOHNSON CITY
423-207-0511
801 Suncrest Drive
Johnson City, TN 37615

PARTS ONLY

JOHNSON CITY
423-207-0504
801 Suncrest Drive
Johnson City, TN 37615

SPECIALTY

Complete Truck & Trailer
865-637-4333
6416 Asheville Highway
Knoxville, TN 37914

VIRGINIA

SALES / SERVICE

ABINGDON
276-628-8103
18285 Lee Highway
Abingdon, VA 24210



PARTS ONLY

NORTON
276-679-1553
442 Kentucky Avenue
Norton, VA 24273

WEST VIRGINIA

SALES / SERVICE

CHARLESTON
304-744-1321
3100 MacCorkle Avenue SW
South Charleston, WV 25303



HUNTINGTON
304-736-3401
5650 US Route 60 East
Huntington, WV 25703



JANE LEW
304-884-7815
Lewis County Industrial Park
Jane Lew, WV 26378



PRINCETON
304-425-7511
406 Turnpike Industrial Road
Princeton, WV 24740



LEASING

CHARLESTON
304-744-1321
3100 MacCorkle Avenue SW
South Charleston, WV 25303

CLARKSBURG
304-624-0505
1129 East Pike Street
Clarksburg, WV 26301

HUNTINGTON
304-523-4567
120 13th Street West
Huntington, WV 25704

PARKERSBURG
304-489-2115
2817 Pike Street
Parkersburg, WV 26101

PARTS ONLY

SUMMERSVILLE
304-872-6044
5310 Webster Road
Summersville, WV 26651

History of Worldwide Equipment

Since 1967

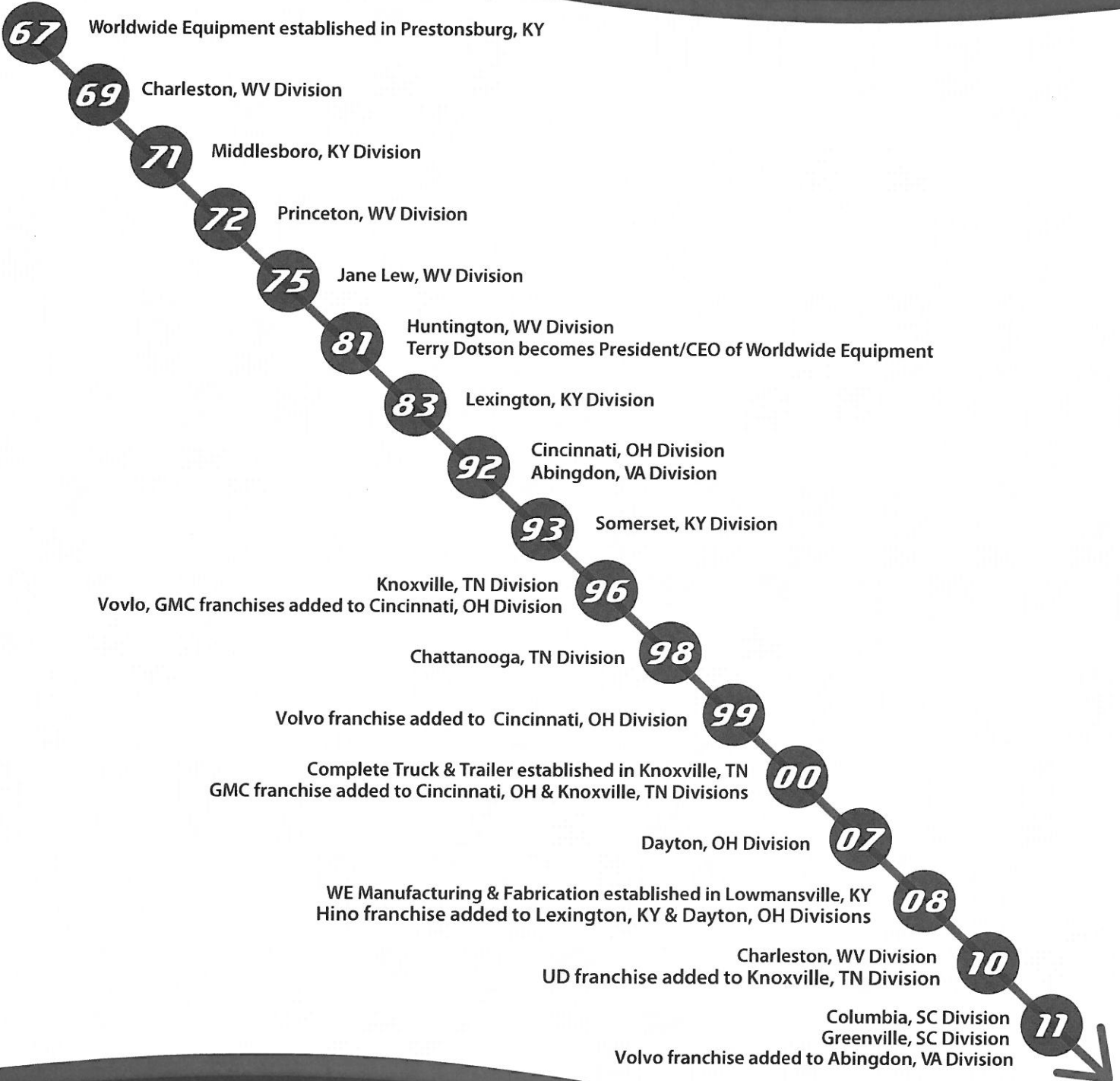

WORLDWIDE
EQUIPMENT
THE TRUCK PEOPLE



CXU613

**WE ENGINEER
THE HEROES
OF THE HIGHWAY**

STANDARD POWERTRAIN SPECIFICATIONS

ENGINE: MACK MP7-325E

- Peak Horsepower – 325HP at 1400-1800 RPM
- Horsepower – 325 HP at 1800 Gov. RPM
- Max. Torque – 1260 lb/ft at 1100-1300 RPM
- V-MAC IV – Total Vehicle Electronics
- Air Compressor – 318 (18.7 cfm)
- Air Cleaner – 11" Single Element
- Alternator – Delco 12V 130A (24SI)
- Batteries, (3) Mack 12V 650/1950 CCA Threaded Stub Type
- Coolant Protection, -34°F (-37°C)
- Mack Coolant Conditioner
- Diesel Particulate Filter – RH Side Under Cab
- Exhaust After Treatment System – Ceramic
- Mack PowerLeash™ Engine Brake for MP7
- Silicone Engine Hoses and Tubing
- Poly-V Fan Belt w/ Automatic Tensioner
- Fan Drive, Electronically Modulated Multi-Speed Viscous
- Flywheel Housing – Aluminum (Lightweight)
- Fuel Water Separator w/ Manual Drain
- Mack EPDM Radiator & Heater Hoses
- Radiator – Aluminum Core
- Starter – Delco 12V 39MT
- Electronic Starter Interlock

TRANSMISSION: MACK *m*DRIVE PREMIUM W/ OVERDRIVE, INCLUDES GRADE GRIPPER AND MACKCELLERATOR

- 12-Speed, Ratios: 11.73 Low – 0.78 High
- Clutch – Meritor/Sachs, Single Plate 17" Organic Material
- Transmission Bell Housing – Aluminum
- Transmission Oil Cooler – *m*DRIVE Gear Box Mounted LH Side Water to Oil Cooler
- Main Driveline – Spicer Extended Lube Series

REAR AXLE: MERITOR MT-40-14X (AMBOID TYPE GEARING)

- 40,000 lb Capacity
- Suspension – Maxlite 40EZ Air Suspension 40,000 lb Rating
- Tires – 295/75R 22.5 (Low Profile)
- Carrier – Malleable Housing
- Wheels – Aluminum Disc (8) 22.5" x 8.25" 10-Hole Hub Piloted
- Hub Material – Aluminum Preset w/ Integrated Spindle Nut
- Brakes – Bendix ES165-07L 16.5" x 7" Stamped Spider
- Brake Drums – Cast Outboard Mounted
- Rear Brake Lining
- Premium Rear Wheel Seals – Hub Oil
- Shock Absorbers – (4) Mounted on Forward and Rear Axles each side
- Slack Adjusters – Automatic
- Spring Brake Chambers – (2) 30/30 Double Diaphragm Type/Mechanical Spring Release

FRONT AXLE: MACK FXL12

- 12,000 lb. Capacity
- Tires – 295/75R 22.5 (Low Profile)
- Wheels – Aluminum Disc (2) 22.5" x 8.25" 10-Hole Hub Piloted
- Hub Material – Aluminum
- Brakes – Bendix ES165-05D 15" x 5" Cast Spider
- Brake Drums – Cast Outboard Mounted
- Front Brake Lining
- Front Wheel Seals – Integrated
- Shock Absorbers – Double Acting Type
- Slack Adjusters – Automatic
- Suspension – Mack Taperleaf 12,000 lb. Ground Load Rating (2 Leaf Spring)
- Steering – TAS65 TRW Integral Power Steering

CXU613



STANDARD CAB INTERIOR/EXTERIOR SPECIFICATIONS

CAB: CA68 CONVENTIONAL

- Air Conditioner w/ Integral Heater – 2 R134a Refrigerant
- Ash Tray
- Cab Mounting – Four Point System w/2 Air Bags and Shocks at Rear
- Cigar Lighter
- Coat Hook
- Co-Pilot Enhanced Driver Display with Button and Stalk Control and GuardDog Maintenance System
- Cup Holders, Driver's & Rider's Side
- Dome Lights – 2 Lamps LH/ 2 Lamps RH
- Galvanized Steel Visibility Doors
- Door Trim – Molded Upper Door Panel & Padded Lower Panel
- Engine Shutoff – Key Type
- Floor Mats – Mack Signature Polyurethane
- Digital Voltmeter – Digital Ambient Air Temp
- Gauges – Air Pressure, Engine Coolant Temperature, Engine Oil Pressure, Engine Oil Temperature, Speedometer, Tachometer, Fuel Level
- Gauge Cluster – Exhaust Pyrometer & Transmission Oil Temperature Gauges
- Grab Handles – Black Finish RH & LH Behind Door
- Grille – Bright Finish Bars w/ Bright Finish Surround
- Hood – One Piece Insulated Fiberglass with Forward tilt 75°
- Fenders – Fiberglass w/ Wheel Splash Aprons and Black Polyarmour Mud Flaps
- Horn – Mack Rectangular Single Trumpet Air Horn, Single Tone w/ Snow Shield
- Identification and Clearance Lights (5)
- Instrument Panel – Charcoal Gray
- Interior Trim: Genuine – Slate Gray
- Keys – (2) Keyed at Random
- Low Air Pressure Indicator Light and Buzzer
- Body Colored Aero Exterior Mirrors
- Overhead Console – 3 Storage Compartments w/ Nets
- Parking Brake On Indicator Light
- AM/FM Premium Stereo, CD, MP3, Weatherband, Handsfree Interface, Bluetooth
- CB – 5 way Binding Post
- Driver Seat – Bostrom Talladega 915 Mid-Back Air Suspension
- Rider Seat – Mack Fixed Mid-Back Non-suspension
- Seat Belts – Lap and Shoulder w/ Cab Mounted Shoulder Belt
- Side Markers – Lamps and Reflectors
- Key Type Starter Switch
- Steering Column – Adjustable Tilt Telescope
- Steering Wheel – Two Spoke Urethane Grip Painted Spokes & Bulldog Horn Cap
- Rear Storage Pouch
- Interior Sun Visor Both Sides w/ Ticket Holder
- Turn Signals – Front Integral w/ Fender
- RH Door Peep Window
- Window Control – Hand Crank Operation
- Windshield – Safety Tinted 2 Piece
- Side and Rear Windows – Safety Tinted
- Windshield Washers – Electric Wiper Mounted w/ Reservoir Mounted under Hood
- Windshield Wipers – 2 Speed Electric Motor w/ Intermittent Feature
- Paint Color – Mack White (Cab, Hood & Fenders), Mack Black (Chassis Running Gear)

ADDITIONAL STANDARD SPECIFICATIONS

AIR/BRAKE

- Dual Air Brake System
- Air Dryer - 1200P w/ Coalescing Filter
- Air Reservoirs – Steel 5961 in³ Capacity
- Mack Road Stability Advantage System
- Parking Brake Control – 2 Valve System, Trailer Supply and Tractor-Trailer Park
- Electrical Plug Holder (Includes Glad Hand Storage)
- Hand Control Valve for Trailer Brakes
- Hose Tender – Pogo Stick, Chassis Mounted
- Manual Drain Valve – Lanyard Control on Supply Tank
- Trailer Connection Package – Semi
- Trailer Air Hoses & Electrical Cord – 12' Non-coiled Type
- Trailer Receptacle – (7) Wire Mounted on Back of Cab

ELECTRICAL

- 12 Volt Electrical System
- Battery Box – Steel w/ Molded Plastic Cover Mounted LH Side
- Courtesy Light Switch – Headlamp and Clearance
- GuardDog Connect Diagnostics
- Daytime Running Lights
- Triples Trailer Electrical Package with 30amp Breaker
- Electric Circuit Protection Package
- Waterproof Electrical Connections
- Headlights – Single Flush Mtd. Rectangular Halogen Lamps
- Rear Lighting – (2) Combination Stop, Tail Directional and Back-Up Lights
- Solid State Turn Signal Flasher

CXU613



STANDARD CHASSIS DIMENSIONS

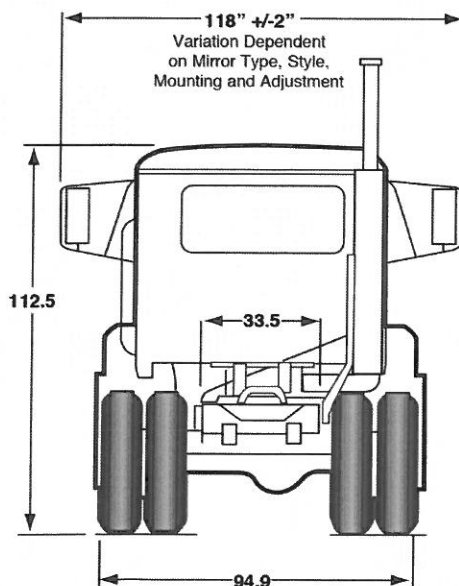
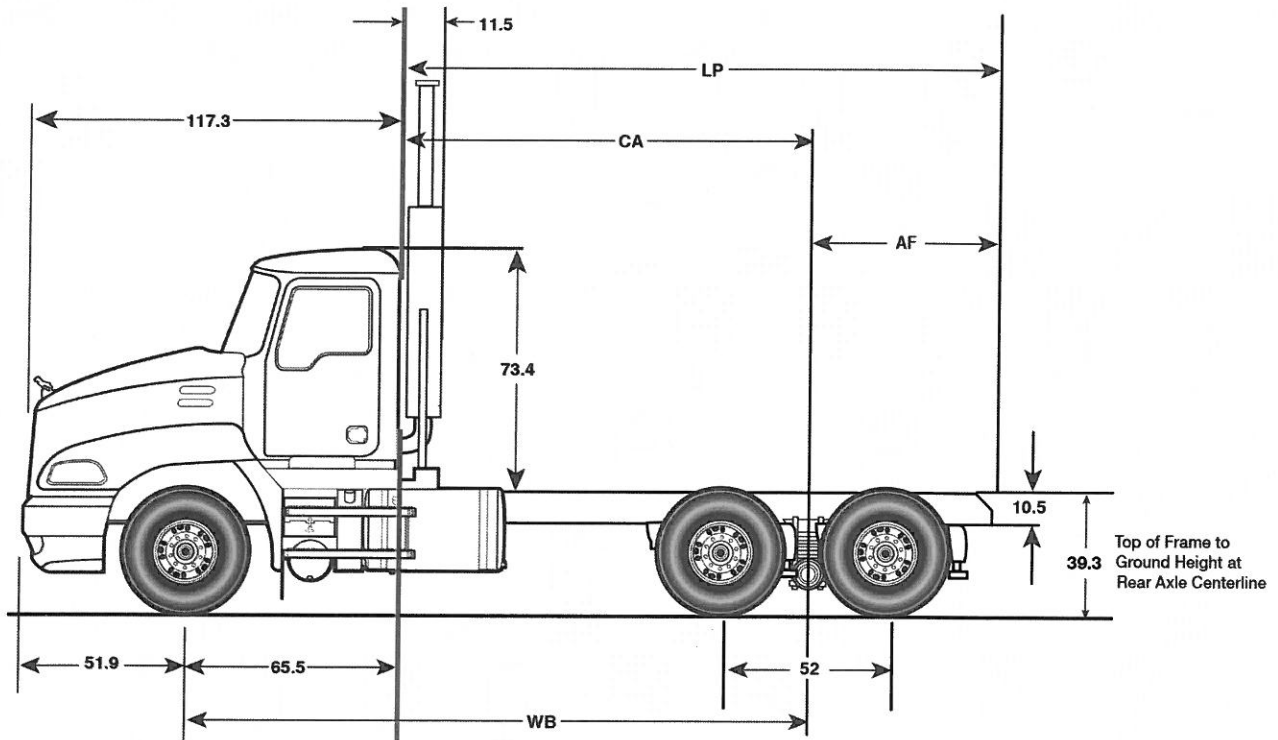

FRAME EQUIPMENT/FUEL TANKS

- Frame Rail w/out Liner – 10.47" x 3.54" x .24" Steel
- Section Modulus – 11.6 in³
- RBM (per rail) – 1,390,000 lb. in.
- Front Bumper – Flush Non-Metallic Aero Argent w/ Charcoal Accent
- Bumper to Back of Cab (BBC) – 117"
- Crossmembers – Steel/Rear Crossmembers – Boxed and Tapered
- Fifth Wheel – Air Slide LH Release Outboard Bolted to Mtg. Angles
- Tapered and Flanged Rail Ends – 28°
- Front Tow Device – (2) Clevis
- Fuel Tanks – 72 Gallon LH & RH, 26" dia. Aluminum
- Fuel Lines – Dual Draw & Return, Material – Nylon Tube
- Diesel Exhaust Fluid (DEF) Tank - 18.4 Gallon, 26" Diameter Frame Mounted on Left Side with Painted Cover

STANDARD WHEELBASE/LOAD PLATFORM

- For standard wheelbase and load platform information refer to your current version of MACKTRAQ

CXU613



AVAILABLE DRIVELINE COMPONENTS

MACK TRANSMISSIONS

MODEL	SPEEDS	RATIOS <small>(LOW/HIGH)</small>
T309	9	11.40 / 0.71
T309LR	9	13.93 / 0.71
T310	10	13.81 / 0.73
T310M	10	17.35 / 0.73
T310ME	10	17.35 / 0.73
T310ME21	10	17.35 / 0.73
T313LR	13	16.42 / 0.71
T313	13	13.44 / 0.71
T31321	13	13.44 / 0.71
T313LR21	13	16.42 / 0.71
T318LR	18	16.42 / 0.71
T318	18	13.44 / 0.71
T31821	18	13.44 / 0.71
T318LR21	18	16.42 / 0.71

MACK *m*DRIVE TRANSMISSIONS

MODEL	SPEEDS	RATIOS <small>(LOW/HIGH)</small>
TmD12AD	12	14.94 / 1.00
TmD12AO	12	11.73 / 0.78

ALLISON TRANSMISSIONS

MODEL	SPEEDS	RATIOS <small>(LOW/HIGH)</small>
4000-HS	5	3.51 / 0.74
4500-HS	5	4.70 / 0.76
3000-RDS	5	3.49 / 0.75
4000-RDS	5	3.51 / 0.74
4500-RDS	5	4.70 / 0.76
4000-HS	6	3.51 / 0.64
4500-HS	6	4.70 / 0.67
3000-RDS	6	3.49 / 0.75
4000-RDS	6	3.51 / 0.64
4500-RDS	6	4.70 / 0.64

EATON FULLER TRANSMISSIONS

MODEL	SPEEDS	RATIOS <small>(LOW/HIGH)</small>
RTX-13609B	9	12.57/0.73
RTX-14609B	9	12.57/0.73
RTX-16709B	9	12.46/0.76
FRO-13210B	10	11.06/0.75
FRO-13210C	10	12.69/0.74
FRO-14210B	10	11.06/0.75
FRO-14210C	10	12.69/0.74
FRO-15210B	10	11.06/0.75
FRO-15210C	10	12.69/0.74
FRO-16210B	10	11.06/0.75
FRO-16210C	10	12.69/0.74
FRO-17210C	10	12.94/0.74
FRO-18210C	10	12.94/0.74
RTO-14908LL	10	14.56/0.74
RTO-16908LL	10	14.56/0.74
FR-13210B	10	14.80/1.00
FR-14210B	10	14.80/1.00
RTLO-14913A	13	12.31/0.73
RTLO-16913A	13	12.31/0.73
RTLO-18913A	13	12.31/0.73
RTLO-20913A	13	12.31/0.73
RT-14915	15	16.94/1.00
RTO-14915	15	13.31/0.79
RTO-16915	15	13.31/0.79
RTLO-14918B	18	14.40/0.73
RTLO-16918B	18	14.40/0.73
RTLO-18918B	18	14.40/0.73
RTLO-20918B	18	14.40/0.73

CXU613



AVAILABLE DRIVELINE COMPONENTS CONTINUED

FRONT AXLES		
CAPACITY	MAKE	MODEL
12,000 lb. [5443 kg]	MACK	FXL12
	DANA SPICER	E12021
	MERITOR	MFS131
	HENDRICKSON	STEERTEX
12,500 lb. [5681 kg]	MACK	FXL12.5
	DANA SPICER	E12021
	HENDRICKSON	STEERTEX
13,200 lb. [6000 kg]	MACK	FXL13.2
	DANA SPICER	E13221
	MERITOR	MPS-131
	HENDRICKSON	STEERTEX
14,600 lb. [6486 kg]	MACK	FXL14.6
	HENDRICKSON	STEERTEX
	MERITOR	MFS-141

REAR AXLES		
CAPACITY	MAKE	MODEL
38,000 lb. [17237 kg]	MACK	S38R
40,000 lb. [18144 kg]	MACK	S40
	DANA SPICER	DS405(P)/DST41(P)
	MERITOR	MT40-14X4C
	MERITOR	MT40-14X4D
	MERITOR	RT40-145A
44,000 lb. [19958 kg]	MACK	S440
46,000 lb. [20866 kg]	MACK	S440-46*/462/462R
	DANA SPICER	RT46-160
	MERITOR	RT46-164EH
	MERITOR	D46-170P

* Available For Municipal Service Only

MP7 ENGINES	
MODEL	HORSEPOWER
MP7-345A	345 HP [257 kW] @ 1500-1700 RPM
	320 HP [239 kW] @ 1950
MP7-325E	325 HP [242 kW] @ 1500-1800 RPM
	325 HP [242 kW] @ 1800
MP7-355E	355 HP [265 kW] @ 1500-1800 RPM
	355 HP [265 kW] @ 1800
MP7-405E	405 HP [302 kW] @ 1450-1900 RPM
	405 HP [302 kW] @ 2100
MP7-405SE	405 HP [302 kW] @ 1450-1900 RPM
	370 HP [276 kW] @ 2100
MP7-345C	345 HP [257 kW] @ 1500-1700 RPM
	320 HP [239 kW] @ 1950
MP7-365C	365 HP [272 kW] @ 1500-1700 RPM
	340 HP [254 kW] @ 1950
MP7-395C	395 HP [295 kW] @ 1500-1700 RPM
	370 HP [276 kW] @ 1950

MP8 ENGINES	
MODEL	HORSEPOWER
MP8-415E	415 HP [310 kW] @ 1500-1700 RPM
	375 HP [280 kW] @ 1800
MP8-445E	445 HP [329 kW] @ 1500-1700 RPM
	400 HP [296 kW] @ 1800
MP8-445SE	445 HP [329 kW] @ 1400-1700 RPM
	430 HP [320 kW] @ 1800
MP8-505E	505 HP [377 kW] @ 1500-1700 RPM
	430 HP [318 kW] @ 1800
MP8-505C+	505 HP [377 kW] @ 1500-1700 RPM
	430 HP [320 kW] @ 1950
MP8-415C	415 HP [309 kW] @ 1500-1700 RPM
	390 HP [291 kW] @ 1950
MP8-445C	445 HP [332 kW] @ 1500-1700 RPM
	420 HP [314 kW] @ 1950
MP8-505C	505 HP [377 kW] @ 1500-1700 RPM
	430 HP [321 kW] @ 1950

VENDOR PREFERENCE CERTIFICATE

Certification and application* is hereby made for Preference in accordance with West Virginia Code, §5A-3-37. (Does not apply to construction contracts). West Virginia Code, §5A-3-37, provides an opportunity for qualifying vendors to request (at the time of bid) preference for their residency status. Such preference is an evaluation method only and will be applied only to the cost bid in accordance with the West Virginia Code. This certificate for application is to be used to request such preference. The Purchasing Division will make the determination of the Vendor Preference, if applicable.

1. Application is made for 2.5% vendor preference for the reason checked:

___ Bidder is an individual resident vendor and has resided continuously in West Virginia for four (4) years immediately preceding the date of this certification; or,

___ Bidder is a partnership, association or corporation resident vendor and has maintained its headquarters or principal place of business continuously in West Virginia for four (4) years immediately preceding the date of this certification; or 80% of the ownership interest of Bidder is held by another individual, partnership, association or corporation resident vendor who has maintained its headquarters or principal place of business continuously in West Virginia for four (4) years immediately preceding the date of this certification; or,

X Bidder is a nonresident vendor which has an affiliate or subsidiary which employs a minimum of one hundred state residents and which has maintained its headquarters or principal place of business within West Virginia continuously for the four (4) years immediately preceding the date of this certification; or,

2. Application is made for 2.5% vendor preference for the reason checked:

___ Bidder is a resident vendor who certifies that, during the life of the contract, on average at least 75% of the employees working on the project being bid are residents of West Virginia who have resided in the state continuously for the two years immediately preceding submission of this bid; or,

3 X Application is made for 2.5% vendor preference for the reason checked:

___ Bidder is a nonresident vendor employing a minimum of one hundred state residents or is a nonresident vendor with an affiliate or subsidiary which maintains its headquarters or principal place of business within West Virginia employing a minimum of one hundred state residents who certifies that, during the life of the contract, on average at least 75% of the employees or Bidder's affiliate's or subsidiary's employees are residents of West Virginia who have resided in the state continuously for the two years immediately preceding submission of this bid; or,

4 X Application is made for 5% vendor preference for the reason checked:

___ Bidder meets either the requirement of both subdivisions (1) and (2) or subdivision (1) and (3) as stated above; or,

5. Application is made for 3.5% vendor preference who is a veteran for the reason checked:

___ Bidder is an individual resident vendor who is a veteran of the United States armed forces, the reserves or the National Guard and has resided in West Virginia continuously for the four years immediately preceding the date on which the bid is submitted; or,

6. Application is made for 3.5% vendor preference who is a veteran for the reason checked:

___ Bidder is a resident vendor who is a veteran of the United States armed forces, the reserves or the National Guard, if, for purposes of producing or distributing the commodities or completing the project which is the subject of the vendor's bid and continuously over the entire term of the project, on average at least seventy-five percent of the vendor's employees are residents of West Virginia who have resided in the state continuously for the two immediately preceding years.

7. Application is made for preference as a non-resident small, women- and minority-owned business, in accordance with West Virginia Code §5A-3-59 and West Virginia Code of State Rules.

___ Bidder has been or expects to be approved prior to contract award by the Purchasing Division as a certified small, women- and minority-owned business.

Bidder understands if the Secretary of Revenue determines that a Bidder receiving preference has failed to continue to meet the requirements for such preference, the Secretary may order the Director of Purchasing to: (a) reject the bid; or (b) assess a penalty against such Bidder in an amount not to exceed 5% of the bid amount and that such penalty will be paid to the contracting agency or deducted from any unpaid balance on the contract or purchase order.

By submission of this certificate, Bidder agrees to disclose any reasonably requested information to the Purchasing Division and authorizes the Department of Revenue to disclose to the Director of Purchasing appropriate information verifying that Bidder has paid the required business taxes, provided that such information does not contain the amounts of taxes paid nor any other information deemed by the Tax Commissioner to be confidential.

Under penalty of law for false swearing (West Virginia Code, §61-5-3), Bidder hereby certifies that this certificate is true and accurate in all respects; and that if a contract is issued to Bidder and if anything contained within this certificate changes during the term of the contract, Bidder will notify the Purchasing Division in writing immediately.

Bidder: Worldwide Equipment Inc

Signed: [Signature]

Date: 10/21/14

Title: Director of Government & Municipal Sales

RFQ No. AGR1500000004

STATE OF WEST VIRGINIA
Purchasing Division

PURCHASING AFFIDAVIT

MANDATE: Under W. Va. Code §5A-3-10a, no contract or renewal of any contract may be awarded by the state or any of its political subdivisions to any vendor or prospective vendor when the vendor or prospective vendor or a related party to the vendor or prospective vendor is a debtor and: (1) the debt owed is an amount greater than one thousand dollars in the aggregate; or (2) the debtor is in employer default.

EXCEPTION: The prohibition listed above does not apply where a vendor has contested any tax administered pursuant to chapter eleven of the W. Va. Code, workers' compensation premium, permit fee or environmental fee or assessment and the matter has not become final or where the vendor has entered into a payment plan or agreement and the vendor is not in default of any of the provisions of such plan or agreement.

DEFINITIONS:

"Debt" means any assessment, premium, penalty, fine, tax or other amount of money owed to the state or any of its political subdivisions because of a judgment, fine, permit violation, license assessment, defaulted workers' compensation premium, penalty or other assessment presently delinquent or due and required to be paid to the state or any of its political subdivisions, including any interest or additional penalties accrued thereon.

"Employer default" means having an outstanding balance or liability to the old fund or to the uninsured employers' fund or being in policy default, as defined in W. Va. Code § 23-2c-2, failure to maintain mandatory workers' compensation coverage, or failure to fully meet its obligations as a workers' compensation self-insured employer. An employer is not in employer default if it has entered into a repayment agreement with the Insurance Commissioner and remains in compliance with the obligations under the repayment agreement.

"Related party" means a party, whether an individual, corporation, partnership, association, limited liability company or any other form or business association or other entity whatsoever, related to any vendor by blood, marriage, ownership or contract through which the party has a relationship of ownership or other interest with the vendor so that the party will actually or by effect receive or control a portion of the benefit, profit or other consideration from performance of a vendor contract with the party receiving an amount that meets or exceeds five percent of the total contract amount.

AFFIRMATION: By signing this form, the vendor's authorized signer affirms and acknowledges under penalty of law for false swearing (W. Va. Code §61-5-3) that neither vendor nor any related party owe a debt as defined above and that neither vendor nor any related party are in employer default as defined above, unless the debt or employer default is permitted under the exception above.

WITNESS THE FOLLOWING SIGNATURE:

Vendor's Name: Worldwide Equipment Inc
Authorized Signature: [Signature] Date: 10/21/14

State of tn
County of KNOX, to-wit:

Taken, subscribed, and sworn to before me this 21ST day of OCTOBER, 2014.

My Commission expires 05-06-18, 20 .

AFFIX SEAL HERE

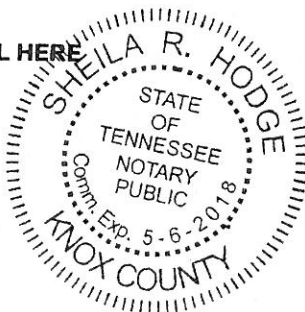

NOTARY PUBLIC Sheila R. Hodge