



West Virginia Purchasing Division

2019 Washington Street, East
Charleston, WV 25305
Telephone: 304-558-2306
General Fax: 304-558-6026
Bid Fax: 304-558-3970

The following documentation is an electronically-submitted vendor response to an advertised solicitation from the *West Virginia Purchasing Bulletin* within the Vendor Self-Service portal at ***wvOASIS.gov***. As part of the State of West Virginia's procurement process, and to maintain the transparency of the bid-opening process, this documentation submitted online is publicly posted by the West Virginia Purchasing Division at ***WVPurchasing.gov*** with any other vendor responses to this solicitation submitted to the Purchasing Division in hard copy format.

Header

List View

General Information | Contact | Default Values | Discount | Document Information

Procurement Folder: 27624

SO Doc Code: CRFQ

Procurement Type: Central Purchase Order

SO Dept: 0803

Vendor ID: 000000114422 

SO Doc ID: DOT1500000088

Legal Name: CRANE 1 SERVICES Inc

Published Date: 4/21/15

Alias/DBA:

Close Date: 5/20/15

Total Bid: \$35,460.00

Close Time: 13:30

Response Date: 05/20/2015 

Status: Closed

Response Time: 11:40

Solicitation Description: Freestanding heavy duty crane system 

Total of Header Attachments: 0

Total of All Attachments: 0



Purchasing Division
 2019 Washington Street East
 Post Office Box 50130
 Charleston, WV 25305-0130

**State of West Virginia
 Solicitation Response**

Proc Folder : 27624

Solicitation Description : Freestanding heavy duty crane system

Proc Type : Central Purchase Order

Date issued	Solicitation Closes	Solicitation No	Version
	2015-05-20 13:30:00	SR 0803 ESR05191500000003879	1

VENDOR

000000114422
 CRANE 1 SERVICES Inc

FOR INFORMATION CONTACT THE BUYER

Misty Delong
 (304) 558-8802
 misty.m.delong@wv.gov

Signature X

FEIN #

DATE

All offers subject to all terms and conditions contained in this solicitation

Line	Comm Ln Desc	Qty	Unit Issue	Unit Price	Ln Total Or Contract Amount
1	Free Standing Over Head Crane System w/ manual bridge	1.00000	EA	\$30,528.00	\$30,528.00

Comm Code	Manufacturer	Specification	Model #
24101654			

Extended Description : Free Standing Over Head Crane System w/ manual bridge and trolley including installation

Line	Comm Ln Desc	Qty	Unit Issue	Unit Price	Ln Total Or Contract Amount
2	Three Ton Crane Hoist single Chain including Installation	1.00000	EA	\$4,932.00	\$4,932.00

Comm Code	Manufacturer	Specification	Model #
24101654			

Extended Description : Three Ton Crane Hoist single Chain including Installation



CRANE 1 SERVICES

Charleston Division

11301 B McCorkle Avenue | Charleston, West Virginia 25315
office: 304.949.1201 | fax: 304.949.1205 | toll free: 888.658.1212
www.crane1services.com

Page 1

May 19, 2015

Proposal #: Q03-05204

West Virginia Division of Highways – District 10
270 Hardwood Lane
Princeton, WV 24740

Attention: Jason Blevins / Misty Delong

Reference: 3 ton Freestanding Crane System
Solicitation No. CRFQ 0803 DOT1500000088

Dear Jason / Misty

Per our recent discussions, CRANE 1 SERVICES is pleased to present the following proposal for your evaluation and consideration.

Application Scope:

CRANE 1 SERVICES shall furnish and install one 3 Ton Capacity, Freestanding Crane System which includes a manual underhung bridge, trolley and a 3 ton H4) Electric Chain Hoist. All Electrification for crane and hoist will be internal with no exposure. System shall be installed and anchored to floor only.

Qty 1 (one) Freestanding Heavy Duty Crane System with Manual Bridge and Trolley

Manufacturer: Kundel
Type: K-Trac
Capacity: 3 ton
Span: 19 ft.
Runway: 36 ft.
End Stops: Open Ended for closer to wall access
End Trucks: Extra Heavy Duty
Bridge Speed: Manual
Pendant Control: NEMA 4
Festoon System: Internal Mainline Bar
Power Supply: 460/3/60
Paint: Yellow

Qty 1 (one) - 3 Ton Capacity – Electric Chain Hoist

Manufacturer: Budgit (USA)
Series: Man Guard
HMI Duty: H4
Capacity: 3 ton
Power Supply: 460/3/60
Available Lift: 16 ft.

Hoist Speed: 10 fpm
Hoist Controls: Contactor Driven
Hoist Brakes: Electric
Limit Switches: Upper and Lower
Hoist Mounting: Top Hook Mount
Hoist Reeving: Single Chain
Trolley Speed: Manual included on crane
Paint Color: Yellow
Weight: 146 lbs.

Installation

-CRANE 1 SERVICES will provide all labor to install the above crane and hoist system in your facility. Customer will provide adequate power supply with floor mounted disconnect for the crane system with junction box located within 2' of the runway for connection to electrification.

-Upon completion of installation, Crane 1 Services will perform an OSHA 1910.179 certified load test with customer supplied weights and provide documentation for your records.

Pricing

3 ton Crane with installation and freight	\$30,528.00
3 ton Hoist with installation and freight (includes load test)	\$4,932.00

Terms and Conditions:

- Proposal based on work being performed during normal working hours, Monday through Friday, 7:30 am to 4:30 pm.
- Permits, if requires are not included in proposal price.
- CRANE 1 SERVICES will supply all required lifts and tools to perform the scope of work unless detailed otherwise in the body of the quote and/or customer's request for quotation.
- CRANE 1 SERVICES will comply with all applicable state and federal safety requirements as well as those policies provided to us that are specific to the organization or site where the work is being performed.
- Unless otherwise noted, prices are quoted based upon free and clear access to the site and equipment. Delays caused by customer or other contractors will result in adders based on actual time delay at our current labor rate.
- Proposal is subject to "C1S Terms and Conditions of Sale" (attached, or available at www.crane1services.com.)
- Proposal shall remain valid for 30 days from issue date.
- Delivery: 6 - 8 Weeks

Payment and Freight Terms:

- Terms: 100% upon Completion
- Freight: FOB Shipping Point, freight charges included in above quote.
- Tax: No allowance

We appreciate the opportunity to provide this proposal and look forward to working with you on this project. Should you have any question concerning the above proposal, please feel free to contact CRANE 1 SERVICES at any time.

Sincerely,
CRANE 1 SERVICES

Kelly Lacy
Territory Sales Manager
Charleston, WV Office

STATE OF WEST VIRGINIA
Purchasing Division

PURCHASING AFFIDAVIT

MANDATE: Under W. Va. Code §5A-3-10a, no contract or renewal of any contract may be awarded by the state or any of its political subdivisions to any vendor or prospective vendor when the vendor or prospective vendor or a related party to the vendor or prospective vendor is a debtor and: (1) the debt owed is an amount greater than one thousand dollars in the aggregate; or (2) the debtor is in employer default.

EXCEPTION: The prohibition listed above does not apply where a vendor has contested any tax administered pursuant to chapter eleven of the W. Va. Code, workers' compensation premium, permit fee or environmental fee or assessment and the matter has not become final or where the vendor has entered into a payment plan or agreement and the vendor is not in default of any of the provisions of such plan or agreement.

DEFINITIONS:

"Debt" means any assessment, premium, penalty, fine, tax or other amount of money owed to the state or any of its political subdivisions because of a judgment, fine, permit violation, license assessment, defaulted workers' compensation premium, penalty or other assessment presently delinquent or due and required to be paid to the state or any of its political subdivisions, including any interest or additional penalties accrued thereon.

"Employer default" means having an outstanding balance or liability to the old fund or to the uninsured employers' fund or being in policy default, as defined in W. Va. Code § 23-2c-2, failure to maintain mandatory workers' compensation coverage, or failure to fully meet its obligations as a workers' compensation self-insured employer. An employer is not in employer default if it has entered into a repayment agreement with the Insurance Commissioner and remains in compliance with the obligations under the repayment agreement.

"Related party" means a party, whether an individual, corporation, partnership, association, limited liability company or any other form or business association or other entity whatsoever, related to any vendor by blood, marriage, ownership or contract through which the party has a relationship of ownership or other interest with the vendor so that the party will actually or by effect receive or control a portion of the benefit, profit or other consideration from performance of a vendor contract with the party receiving an amount that meets or exceeds five percent of the total contract amount.

AFFIRMATION: By signing this form, the vendor's authorized signer affirms and acknowledges under penalty of law for false swearing (W. Va. Code §61-5-3) that neither vendor nor any related party owe a debt as defined above and that neither vendor nor any related party are in employer default as defined above, unless the debt or employer default is permitted under the exception above.

WITNESS THE FOLLOWING SIGNATURE:

Vendor's Name: Crane I Services

Authorized Signature: [Signature] Date: 5/19/15

State of West Virginia

County of Raleigh, to-wit:

Taken, subscribed, and sworn to before me this 19th day of May, 2015.

My Commission expires June 6, 2024.

AFFIX SEAL HERE

NOTARY PUBLIC [Signature]
Purchasing Affidavit (Revised 07/01/2012)

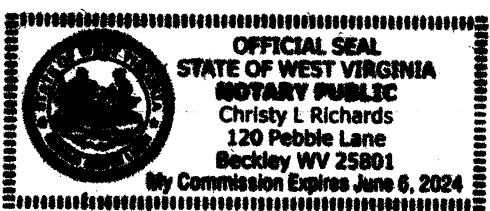

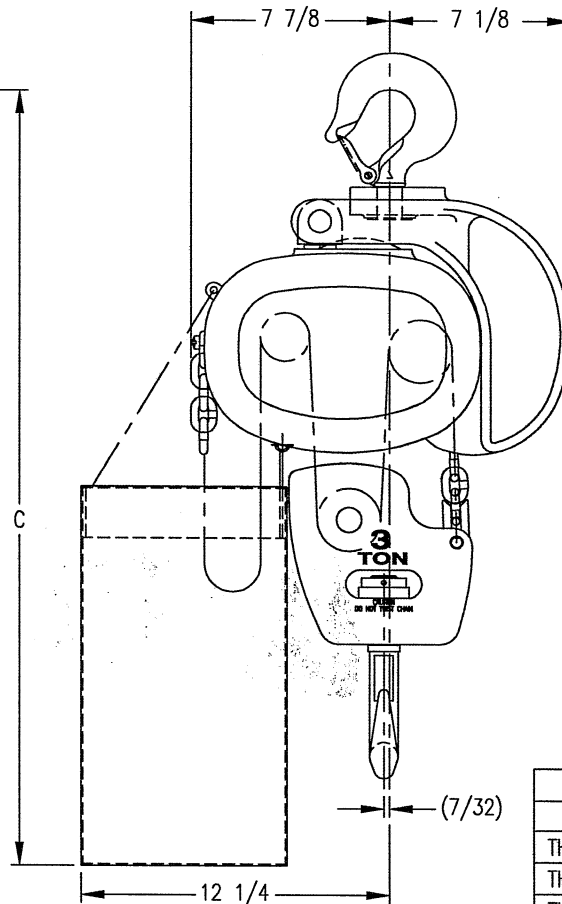
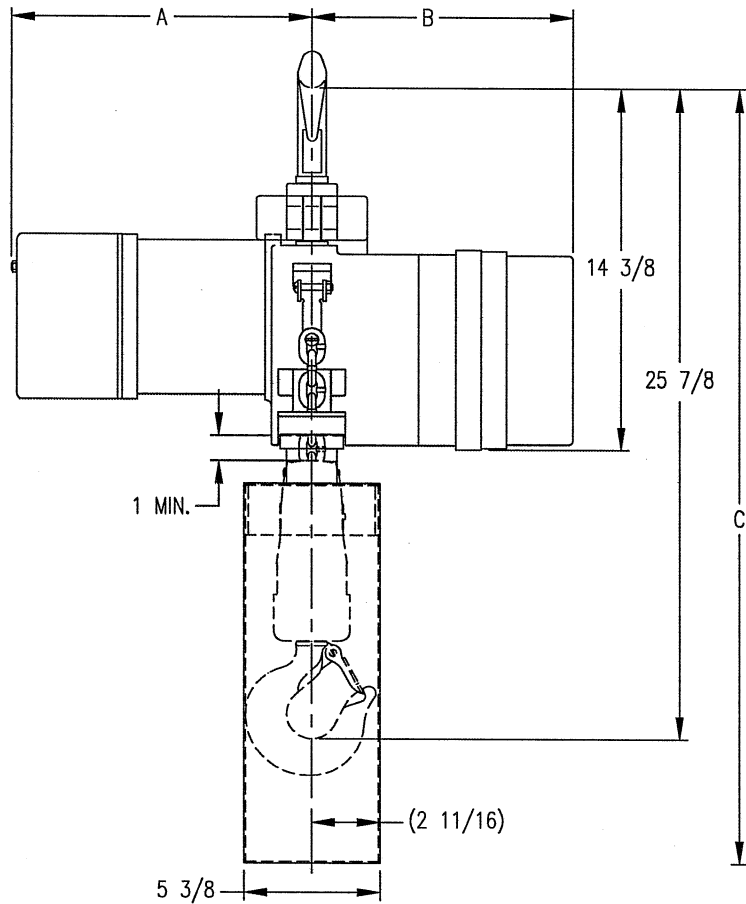

OPTIONAL CHAIN CONTAINER		
LIFT	PART #	"C" DIM.
THRU 10'	805435	30 7/8
THRU 15'	805436	34 7/8
THRU 20'	805437	38 7/8

* 2-SPEED HOIST HAS A 2 1/4 H.P. MOTOR

CAPACITY (ton)	HOIST SPEED (fpm)	MOTOR H.P.	PHASE	"A" DIMENSION		"B" DIMENSION	
				1-SPEED	2-SPEED	1-SPEED	2-SPEED
3	5	1	1	14 1/4	N/A	N/A	N/A
3	5	1	3	11 7/8	14 1/4	10 5/16	10 5/16
3	10	2 1/2*	3	14 1/4			11 5/16

NO.	CHANGE	DATE	ITL.	CLEARANCE DIAGRAM	
				3 TON ELECTRIC CHAIN HOIST	
				HOOK SUSPENSION	
				DA. 2/09/07	 division of Columbus McKinnon Corporation Muskegon, Michigan 49443
				DR. MDH	
				CK.	
EVALUATE PRODUCT ASSEMBLY PER ENG-5-76				AP.	23470004

DESIGN APPEARANCE

