



Purchasing Division
 2019 Washington Street East
 Post Office Box 50130
 Charleston, WV 25305-0130

State of West Virginia
 Request for Quotation

Proc Folder: 82124

Doc Description: AUTOMATIC BRINE SOLUTION PRODUCTION SYSTEM EQUIPMENT

Proc Type: Central Master Agreement

Date Issued	Solicitation Closes	Solicitation No	Version
2015-04-03	2015-04-28 13:30:00	CRFQ 0803 DOT1500000079	1

BID RECEIVING LOCATION

BID CLERK
 DEPARTMENT OF ADMINISTRATION
 PURCHASING DIVISION
 2019 WASHINGTON ST E
 CHARLESTON WV 25305
 US

VENDOR

Vendor Name, Address and Telephone Number:

BAKER TRUCK EQUIPMENT CO.
 PO BOX 482
 HURRICANE, WV 25526
 PHONE: 304-722-3814

04/27/15 14:54:50
 WV Purchasing Division

FOR INFORMATION CONTACT THE BUYER

Misty DeLong
 (304) 558-8802
 misty.m.delong@wv.gov

Signature X

FEIN # 550711783

DATE 4/24/2015

All offers subject to all terms and conditions contained in this solicitation

INVOICE TO		SHIP TO	
ALL STATE AGENCIES VARIOUS LOCATIONS AS INDICATED BY ORDER		STATE OF WEST VIRGINIA VARIOUS LOCATIONS AS INDICATED BY ORDER	
No City	WV99999	No City	WV 99999
US		US	

Line	Comm Ln Desc	Qty	Unit Issue	Unit Price	Total Price
1	AUTOMATIC BRINE SOLUTION PRODUCTION SYSTEM	1.00000	EA	\$58,333.00	\$58,333.00

Comm Code	Manufacturer	Specification	Model #
20122400	HENDERSON		BRINE XTREME

Extended Description :
ITEM 3.3.1 AUTOMATIC BRINE MAKER WITH REMOTE FILL CAPABILITIES

INVOICE TO		SHIP TO	
ALL STATE AGENCIES VARIOUS LOCATIONS AS INDICATED BY ORDER		STATE OF WEST VIRGINIA VARIOUS LOCATIONS AS INDICATED BY ORDER	
No City	WV99999	No City	WV 99999
US		US	

Line	Comm Ln Desc	Qty	Unit Issue	Unit Price	Total Price
2	AUTOMATIC BRINE SOLUTION PRODUCTION SYSTEM	1.00000	EA	\$60,360.00	\$60,360.00

Comm Code	Manufacturer	Specification	Model #
20122400	HENDERSON		BRINE XTREME

Extended Description :
ITEM 3.3.2 AUTOMATIC BRINE MAKER WITH REMOTE FILL CAPABILITIES INCLUDING ONE ADDITIVE BLENDING CAPABILITY

INVOICE TO		SHIP TO	
ALL STATE AGENCIES VARIOUS LOCATIONS AS INDICATED BY ORDER		STATE OF WEST VIRGINIA VARIOUS LOCATIONS AS INDICATED BY ORDER	
No City	WV99999	No City	WV 99999
US		US	

Line	Comm Ln Desc	Qty	Unit Issue	Unit Price	Total Price
3	AUTOMATIC BRINE SOLUTION PRODUCTION SYSTEM	1.00000	EA	\$62,388.00	\$62,388.00

Comm Code	Manufacturer	Specification	Model #
20122400	HENDERSON		BRINE XTREME

Extended Description :

ITEM 3.3.3 AUTOMATIC BRINE MAKER WITH REMOTE FILL CAPABILITIES INCLUDING TWO ADDITIVE BLENDING CAPABILITY

REQUEST FOR QUOTATION
Automatic Brine Solution Production System Equipment

Contract Manager: VIRGIL MAYSE
Telephone Number: 304-722-3814
Fax Number: 304-722-3829
Email Address: virgil@bakerwv.com

CERTIFICATION AND SIGNATURE PAGE

By signing below, or submitting documentation through wvOASIS, I certify that I have reviewed this Solicitation in its entirety; understand the requirements, terms and conditions, and other information contained herein; that I am submitting this bid, offer or proposal for review and consideration; that I am authorized by the vendor to execute and submit this bid, offer, or proposal, or any documents related thereto on vendor's behalf; that I am authorized to bind the vendor in a contractual relationship; and that to the best of my knowledge, the vendor has properly registered with any State agency that may require registration.

BAKER TRUCK EQUIPMENT CO.

(Company)

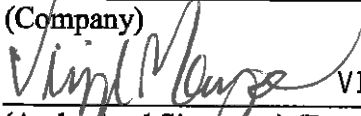

VIRGIL MAYSE , SALES REP.

(Authorized Signature) (Representative Name, Title)

304-722-3814 304-722-3829 4/24/2015

(Phone Number) (Fax Number) (Date)

ADDENDUM ACKNOWLEDGEMENT FORM
SOLICITATION NO.: CRFQ DOT15000079

Instructions: Please acknowledge receipt of all addenda issued with this solicitation by completing this addendum acknowledgment form. Check the box next to each addendum received and sign below. Failure to acknowledge addenda may result in bid disqualification.

Acknowledgment: I hereby acknowledge receipt of the following addenda and have made the necessary revisions to my proposal, plans and/or specification, etc.

Addendum Numbers Received:

(Check the box next to each addendum received)

- | | |
|---|--|
| <input type="checkbox"/> Addendum No. 1 | <input type="checkbox"/> Addendum No. 6 |
| <input type="checkbox"/> Addendum No. 2 | <input type="checkbox"/> Addendum No. 7 |
| <input type="checkbox"/> Addendum No. 3 | <input type="checkbox"/> Addendum No. 8 |
| <input type="checkbox"/> Addendum No. 4 | <input type="checkbox"/> Addendum No. 9 |
| <input type="checkbox"/> Addendum No. 5 | <input type="checkbox"/> Addendum No. 10 |

I understand that failure to confirm the receipt of addenda may be cause for rejection of this bid. I further understand that any verbal representation made or assumed to be made during any oral discussion held between Vendor's representatives and any state personnel is not binding. Only the information issued in writing and added to the specifications by an official addendum is binding.

BAKER TRUCK EQUIPMENT CO.

Company

Authorized Signature

4/24/2015

Date

NOTE: This addendum acknowledgement should be submitted with the bid to expedite document processing.

Professional Grade Salt Brine Made Easy

The BrineXtreme Pro makes continuous salt brine production simple. Connect to power, connect to water, fill the hopper with rock salt, hit start and you're making professional grade salt brine. It really is that simple.

Before entering the mid-range class of brine makers loaded with batch making systems, a full evaluation of existing models was conducted. The results revealed several deficiencies, including: low volume production rates, unreliable accuracy of brine concentration, labor intensive production process and difficulty discarding un-dissolved material.

The BrineXtreme Pro is an easy to operate workhorse that delivers: true plug and play installation, a 4.67 cu. yd. salt hopper, production rates up to 6,000 GPH, salt concentration accurate to 0.001 SG, 100% automation and repeatability, protected mechanicals, 135 sq. in. opening for clean out of large solids, splash free brine transfer, intuitive 6" LCD touch screen display, data logging, storage tank level monitoring, UL Listed salinity control and more.

When you need professional grade salt brine fast, without the headache or hassle, look no further. The BrineXtreme Pro is brought to you by...

The Dependable Ones

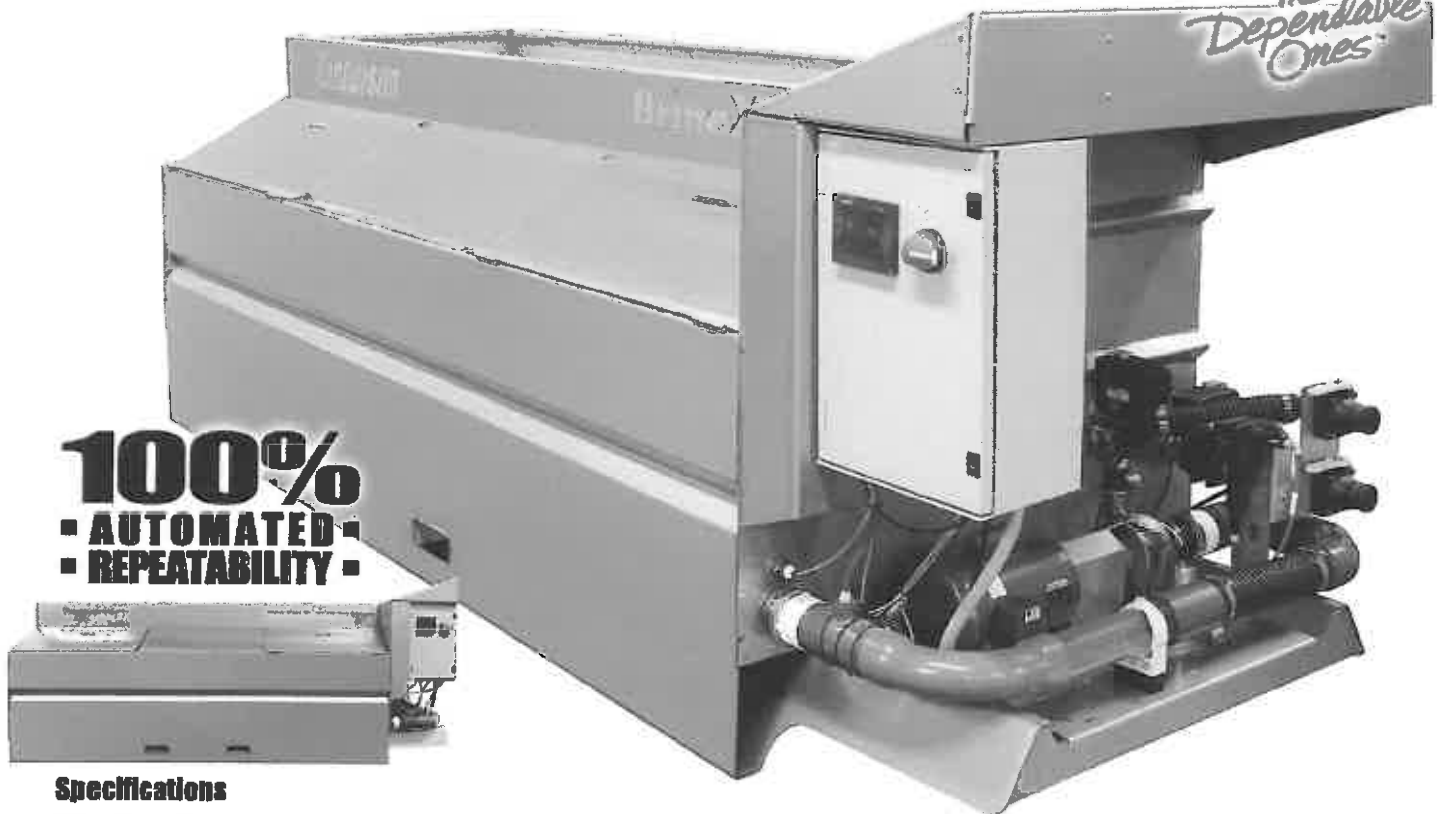

100%
- AUTOMATED -
- REPEATABILITY -

Specifications

Brine Production

- Continuous – up to 6,000 GPH
- 100% Automated
- Side Flow
- Handles All Salt – treated or untreated

Salt Hopper

- Capacity: 4.67 cu. yd.
- Dimensions: 132" L x 63" H x 36" W
- Splash free brine transfer
- Dual overflow protection built-in

Salinity Control

- 100% Automated
- 6" LCD touch screen
- Data logging
- Storage tank level monitoring

- Built-in self diagnostics
- UL Listed
- Remote access (optional)
- Remote truck fill (optional)

Salt Concentration Measuring Method

- 100% Automated
- Density – accurate to 0.001 SG

Clean Out

- Easy clean out
- Large Solids – 15" W x 9" H (135 sq. in.) quick-latch removable panel
- Fines – 3" butterfly valve for fresh water flush
- Sloped floor

Construction & Components

- Tanks: stainless steel with v-crimps, boosting structural strength
- Valves: electric actuated (24v DC)
- Motor: industrial grade 3 HP / 230v single phase
- Pump: cast stainless / 110 GPM
- Pump Design: pedestal
- Self-contained design
- Mechanicals: protected
- Forklift Pockets: built-in

Dimensions & Weight

- Footprint: 159" L x 63" H x 59" W
- Weight: 2,500 lb.

Warranty

- 1-year

FEATURES & BENEFITS

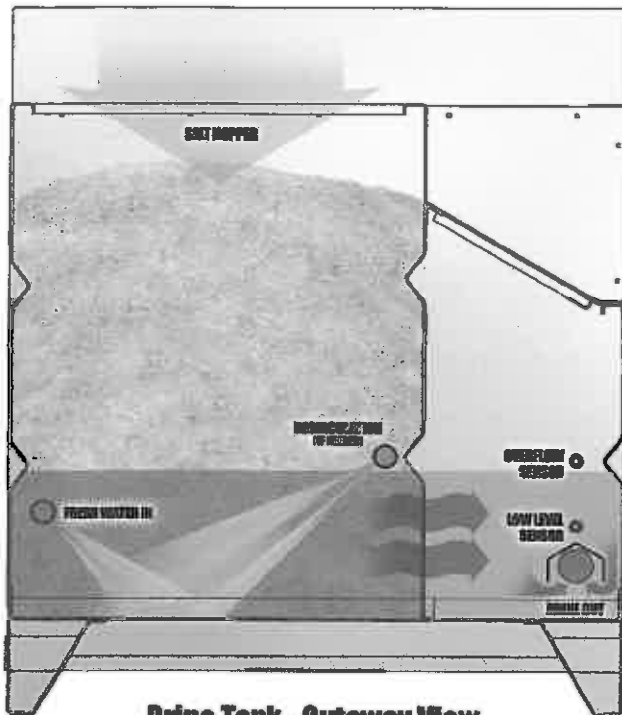

Brine Tank - Cutaway View

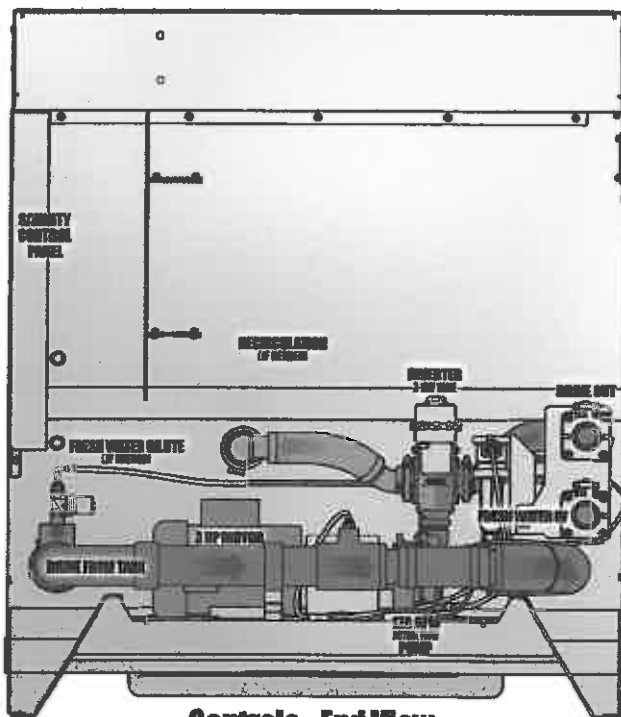

Controls - End View

Continuous Brine Production

Eliminates the start and stop repetition employed by batch making systems.

100% Automated

No manual adjustments or monitoring required. Simply add rock salt to the hopper, turn on the water supply and hit start on the LCD touch screen.

Side Flow Design

Placement of water and recirculation lines keeps brine moving and sediment free.

Large Salt Hopper

Holds up to 4.67 cu. yd. of rock salt and is wide enough for industrial sized front-end loaders.

Splash Free Brine Transfer

Brine is transferred through stainless steel screens built into the dividing wall, eliminating splash or mist.

Overflow Production

Dual overflow protection built into the system.

Data Logging

Tracks brine making activity for your records.

Storage Tank Monitoring

Constant monitoring of brine levels in your storage tanks.

Built-in Self Diagnostics

The system comes complete with built-in trouble shooting software.

UL Listed Salinity Control

Have peace of mind knowing your system is compliant with stringent safety and electrical standards.

100% Automated Salt Concentration Measuring

Automated measuring delivers a precise 23.3% salt concentration by weight (accurate to 0.001 SG), eliminating the need for manual and/or constant monitoring.

Easy Clean Out – Large Solids

Sloped floor and large (15" wide by 9" tall – 135 sq. in.) quick-latch panel allow for easy removal of un-dissolvable material.

Easy Clean Out – Fines

Sloped floor and large (3") manual butterfly valve allow for easy fresh water flush of fine sediment.

Premium Construction

The entire tank is constructed of stainless steel and uses "V" crimp technology to guarantee structural integrity.

Premium Valves

The salinity control manages electric actuated valves, eliminating the need for constant monitoring and/or manual adjustments.

Premium Motor

The system incorporates an industrial grade 3 HP / 230v single phase motor.

Premium Pump

A cast stainless steel pump, rated up to 110 GPM is used to ensure high volume output is maintained.

Pedestal Pump Design

Added protection allows the motor to maintain a safe distance from the pump, in the event of a seal failure.

Self-Contained Design

Plug and play installation. Simply connect electricity, fresh water and brine to storage tank line to get started.

Protected Mechanicals

A stainless hood and raised platform keep mechanicals away from rock salt and liquid.

©Henderson Products, Inc. reserves the right in pursuit of continuous product improvement to change specifications used herein. As a custom manufacturer of truck bodies, truck equipment and brine producing systems, additional product options may be available that are not shown here.



1085 S. Third St., Manchester, IA 52057
Toll Free: (800) 359-4970
www.hendersonproducts.com



HP-198 5M 08/14

Professional Grade Brine Filling Station

Henderson's BrineXtreme Truck Fill Pro is another giant leap forward in the brine making industry. This advanced standalone filling station was designed as a companion product for the BrineXtreme Pro and BrineXtreme Mobile Unit.

The BrineXtreme Truck Fill Pro opens a new world of opportunities for our mid-range and mobile brine making solutions. Features include: modular

design, plug-n-play installation, blends up to 3 products, data logging, remote access, password protection, multiple user setup and more.

When you need professional grade salt brine solutions, without the headache or hassle, look no further. The BrineXtreme Truck Fill Pro is brought to you by...

The Dependable Ones[™]

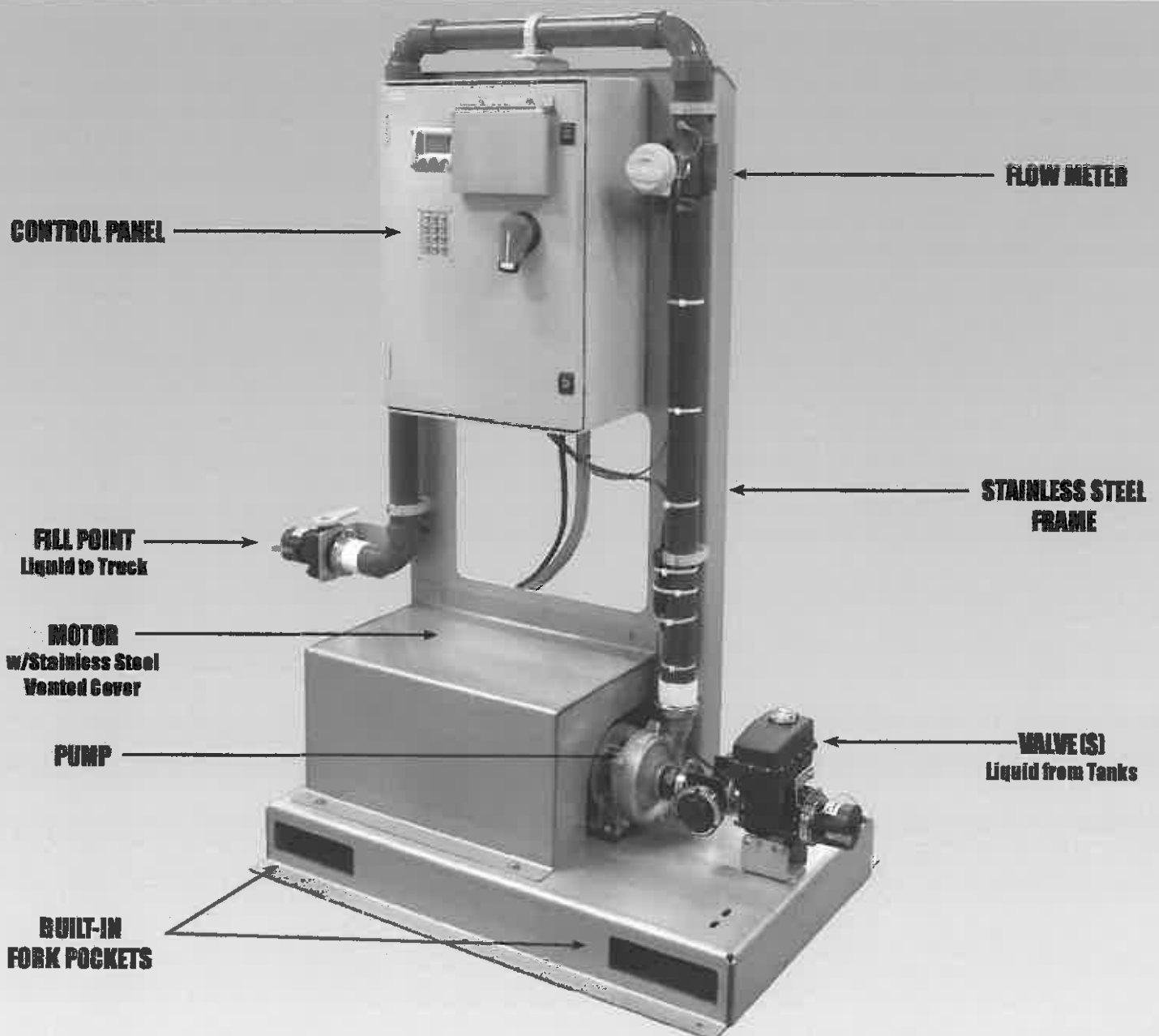

FEATURES & BENEFITS

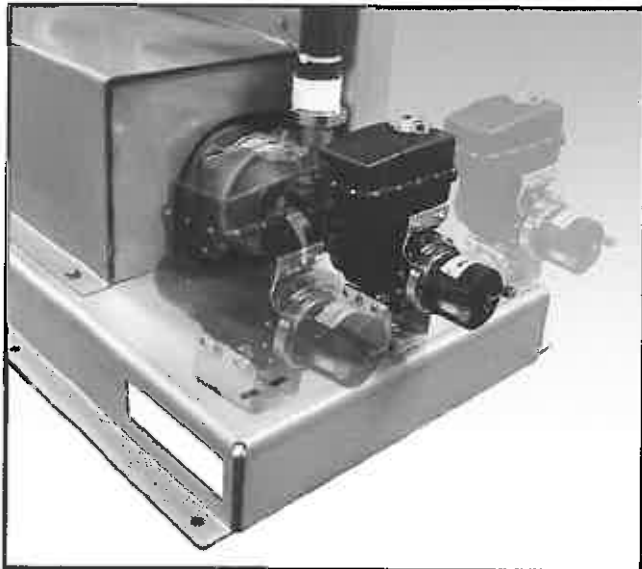
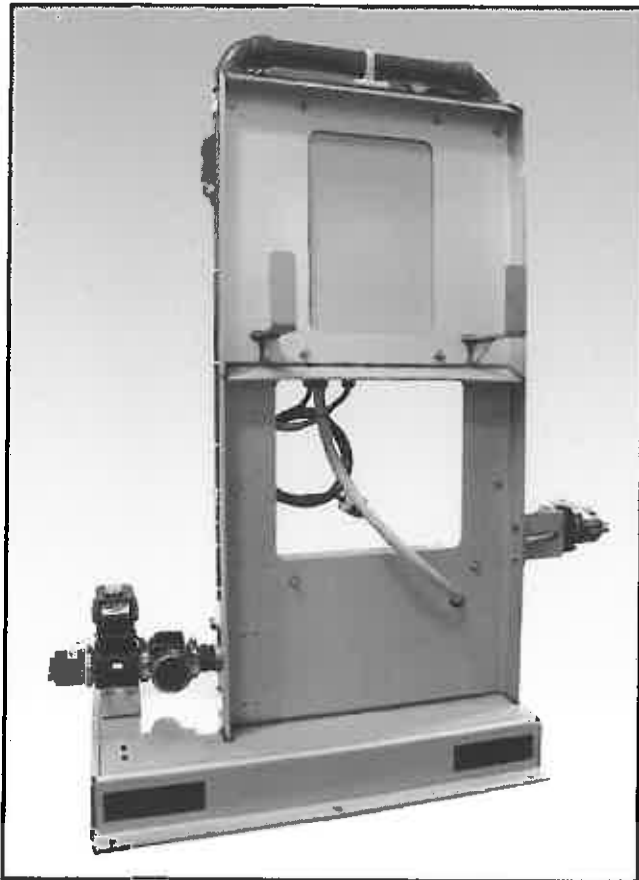

MODULAR DESIGN

A free standing truck fill station. Installs outdoors, near your liquid tanks and offers 24/7 accessibility.

PLUG-N-PLAY INSTALLATION

Fast and easy installation. Control panel setup is accomplished within minutes.

BLEND/STACKING

Combines up to 3 products. This feature brings automated stacking capabilities to the BrineXtreme Pro and the BrineXtreme Mobile Unit.

MULTIPLE USERS

Through the use of unique PIN numbers, you can have up to as many as 30 different users or accounts.

DATA LOGGING

Records output: volume and mixture details into an easy to read .CSV file format. Data can be collected via LAN or USB.

REMOTE ACCESS

Provides system manager with access to data and controls via LAN, WiFi or the optional cellular gateway.

SECURE DATA

Password protection keeps your data safe and secure.

SPECIFICATIONS

DIMENSIONS: 56.03" wide, 66.41" high, 27.64" deep

SHIPPING WEIGHT: 580 lb.

FRAME CONSTRUCTION: stainless steel

MOTOR: 3 hp, 18 amp, 208/240v single phase

PUMP: cast stainless pedestal design

VALVES: electric, IP67

FILL RATE: 100 gpm

FLOW METER: solid state magmeter

CABINET: NEMA 4x

INPUT: key pad and LCD touch screen

CONNECTIONS: 2" cam lock

UL LISTED: yes



©Henderson Products, Inc. reserves the right in pursuit of continuous product improvement to change specifications used herein. As a custom manufacturer of truck bodies, truck equipment and brine producing systems, additional product options may be available that are not shown here.

Henderson[®]

1085 S. Third St., Manchester, IA 52057

Toll Free: (800) 359-4970

www.hendersonproducts.com

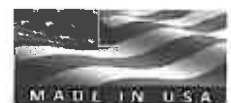

HP-199 2.5M 09/14



A. PARTS REPLACEMENT AND REPAIR:

Henderson Products Inc warrants its manufactured products to be free from defects in material or workmanship for a period of one year after delivery to the original user, or 18 months after factory invoice, whichever occurs first. This warranty of our products under normal use and service is limited to replacement and repair, at the company's factory, of any parts which are returned to the factory freight prepaid, and upon examination found to be defective.

B. EXCLUSIONS:

1. This warranty is expressly limited to parts replacement and repair, and is not transferable. Any expressed warranty not herein provided, and any remedy for breach of contract is excluded and disclaimed. The implied warranties of merchantability and of fitness for any particular purpose are limited to one year from delivery to the original user, or 18 months from factory invoice, whichever occurs first.
2. Any component or part manufactured by others will carry that manufacturer's warranty, and in no case will Henderson Products Inc be liable, either expressed or implied, for warranties in excess of those made by the original manufacturer.
3. Henderson Products Inc shall not be liable for loss of time, manufacturing costs, labor, material, loss of profits, incidental, special or consequential damages, direct or indirect, because of defective products, whether due to claims arising under the contract of sale or independently thereof, and whether or not such claim is based on contract, tort or warranty.
4. Repairs or modifications done by others, or parts from other sources outside the company's factory are not covered by this warranty.
5. No agent, employee, or representative of Henderson Products Inc has any authority to make any affirmation, representation, or warranty concerning Henderson Products Inc products, except as specifically stated above.

WARRANTY PROCEDURE

1. Prior authorization by Henderson Products Inc must be obtained for all warranty work.
2. Contact our distributor or Henderson Products Inc giving complete details of your request, the unit involved, including serial number, date purchased, who purchased from, and the nature of or reason for the claim.
3. A Claim number will be assigned, and is required, whenever any warranty is to be paid either in the form of cash, credit, replacement of parts, or service work. The assignment of this does not guarantee warranty will be allowed. This number is to identify the request and track parts that may need to be returned.
4. When warranty replacement parts are shipped, you may be required to return defective part(s) for inspection by Henderson Products Inc or the original manufacturer. In this case, you will be invoiced for shipment of new components until the old unit is returned.

State of West Virginia VENDOR PREFERENCE CERTIFICATE

Certification and application* is hereby made for Preference in accordance with **West Virginia Code**, §5A-3-37. (Does not apply to construction contracts). **West Virginia Code**, §5A-3-37, provides an opportunity for qualifying vendors to request (at the time of bid) preference for their residency status. Such preference is an evaluation method only and will be applied only to the cost bid in accordance with the **West Virginia Code**. This certificate for application is to be used to request such preference. The Purchasing Division will make the determination of the Vendor Preference, if applicable.

1. Application is made for 2.5% vendor preference for the reason checked:

Bidder is an individual resident vendor and has resided continuously in West Virginia for four (4) years immediately preceding the date of this certification; or,

Bidder is a partnership, association or corporation resident vendor and has maintained its headquarters or principal place of business continuously in West Virginia for four (4) years immediately preceding the date of this certification; or 80% of the ownership interest of Bidder is held by another individual, partnership, association or corporation resident vendor who has maintained its headquarters or principal place of business continuously in West Virginia for four (4) years immediately preceding the date of this certification; or,

Bidder is a nonresident vendor which has an affiliate or subsidiary which employs a minimum of one hundred state residents and which has maintained its headquarters or principal place of business within West Virginia continuously for the four (4) years immediately preceding the date of this certification; or,

2. Application is made for 2.5% vendor preference for the reason checked:

Bidder is a resident vendor who certifies that, during the life of the contract, on average at least 75% of the employees working on the project being bid are residents of West Virginia who have resided in the state continuously for the two years immediately preceding submission of this bid; or,

3. Application is made for 2.5% vendor preference for the reason checked:

Bidder is a nonresident vendor employing a minimum of one hundred state residents or is a nonresident vendor with an affiliate or subsidiary which maintains its headquarters or principal place of business within West Virginia employing a minimum of one hundred state residents who certifies that, during the life of the contract, on average at least 75% of the employees or Bidder's affiliate's or subsidiary's employees are residents of West Virginia who have resided in the state continuously for the two years immediately preceding submission of this bid; or,

4. Application is made for 5% vendor preference for the reason checked:

Bidder meets either the requirement of both subdivisions (1) and (2) or subdivision (1) and (3) as stated above; or,

5. Application is made for 3.5% vendor preference who is a veteran for the reason checked:

Bidder is an individual resident vendor who is a veteran of the United States armed forces, the reserves or the National Guard and has resided in West Virginia continuously for the four years immediately preceding the date on which the bid is submitted; or,

6. Application is made for 3.5% vendor preference who is a veteran for the reason checked:

Bidder is a resident vendor who is a veteran of the United States armed forces, the reserves or the National Guard, if, for purposes of producing or distributing the commodities or completing the project which is the subject of the vendor's bid and continuously over the entire term of the project, on average at least seventy-five percent of the vendor's employees are residents of West Virginia who have resided in the state continuously for the two immediately preceding years.

7. Application is made for preference as a non-resident small, women- and minority-owned business, in accordance with West Virginia Code §5A-3-59 and West Virginia Code of State Rules.

Bidder has been or expects to be approved prior to contract award by the Purchasing Division as a certified small, women- and minority-owned business.

Bidder understands if the Secretary of Revenue determines that a Bidder receiving preference has failed to continue to meet the requirements for such preference, the Secretary may order the Director of Purchasing to: (a) reject the bid; or (b) assess a penalty against such Bidder in an amount not to exceed 5% of the bid amount and that such penalty will be paid to the contracting agency or deducted from any unpaid balance on the contract or purchase order.

By submission of this certificate, Bidder agrees to disclose any reasonably requested information to the Purchasing Division and authorizes the Department of Revenue to disclose to the Director of Purchasing appropriate information verifying that Bidder has paid the required business taxes, provided that such information does not contain the amounts of taxes paid nor any other information deemed by the Tax Commissioner to be confidential.

Under penalty of law for false swearing (West Virginia Code, §61-5-3), Bidder hereby certifies that this certificate is true and accurate in all respects; and that if a contract is issued to Bidder and if anything contained within this certificate changes during the term of the contract, Bidder will notify the Purchasing Division in writing immediately.

Bidder: BAKER TRUCK EQUIPMENT CO.

Signed: 

Date: 4/24/2015

Title: SALES REP.

STATE OF WEST VIRGINIA
Purchasing Division

PURCHASING AFFIDAVIT

MANDATE: Under W. Va. Code §5A-3-10a, no contract or renewal of any contract may be awarded by the state or any of its political subdivisions to any vendor or prospective vendor when the vendor or prospective vendor or a related party to the vendor or prospective vendor is a debtor and: (1) the debt owed is an amount greater than one thousand dollars in the aggregate; or (2) the debtor is in employer default.

EXCEPTION: The prohibition listed above does not apply where a vendor has contested any tax administered pursuant to chapter eleven of the W. Va. Code, workers' compensation premium, permit fee or environmental fee or assessment and the matter has not become final or where the vendor has entered into a payment plan or agreement and the vendor is not in default of any of the provisions of such plan or agreement.

DEFINITIONS:

"Debt" means any assessment, premium, penalty, fine, tax or other amount of money owed to the state or any of its political subdivisions because of a judgment, fine, permit violation, license assessment, defaulted workers' compensation premium, penalty or other assessment presently delinquent or due and required to be paid to the state or any of its political subdivisions, including any interest or additional penalties accrued thereon.

"Employer default" means having an outstanding balance or liability to the old fund or to the uninsured employers' fund or being in policy default, as defined in W. Va. Code § 23-2c-2, failure to maintain mandatory workers' compensation coverage, or failure to fully meet its obligations as a workers' compensation self-insured employer. An employer is not in employer default if it has entered into a repayment agreement with the Insurance Commissioner and remains in compliance with the obligations under the repayment agreement.

"Related party" means a party, whether an individual, corporation, partnership, association, limited liability company or any other form or business association or other entity whatsoever, related to any vendor by blood, marriage, ownership or contract through which the party has a relationship of ownership or other interest with the vendor so that the party will actually or by effect receive or control a portion of the benefit, profit or other consideration from performance of a vendor contract with the party receiving an amount that meets or exceeds five percent of the total contract amount.

AFFIRMATION: By signing this form, the vendor's authorized signer affirms and acknowledges under penalty of law for false swearing (W. Va. Code §61-5-3) that neither vendor nor any related party owe a debt as defined above and that neither vendor nor any related party are in employer default as defined above, unless the debt or employer default is permitted under the exception above.

WITNESS THE FOLLOWING SIGNATURE:

Vendor's Name: BAKER TRUCK EQUIPMENT CO.

Authorized Signature: _____

Date: 4/24/2015

State of WEST VIRGINIA

County of PUTNAM, to-wit:

Taken, subscribed, and sworn to before me this 27 day of APRIL, 2015.

My Commission expires NOVEMBER 19, 2022

AFFIX SEAL HERE

NOTARY PUBLIC

Purchasing Affidavit (Revised 07/01/2012)

