



Purchasing Division
 2019 Washington Street East
 Post Office Box 50130
 Charleston, WV 25305-0130

State of West Virginia
 Request for Quotation
 19 - Highways

Proc Folder: 47340

Doc Description: PORTABLE SIGN STANDS AND REFLECTIVE ROLL-UP SIGNS

Proc Type: Central Master Agreement

Date Issued	Solicitation Closes	Solicitation No	Version
2015-02-23	2015-03-18 13:30:00	CRFQ 0803 DOT1500000059	1

BID RECEIVING LOCATION

BID CLERK

DEPARTMENT OF ADMINISTRATION
 PURCHASING DIVISION
 2019 WASHINGTON ST E
 CHARLESTON
 US

WV 25305

VENDOR

Vendor Name, Address and Telephone Number:

Highway Safety Inc
 P.O. Box 908
 Ceredo, WV 25507
 304-453-5636

03/18/15 10:53:56
 WV Purchasing Division

FOR INFORMATION CONTACT THE BUYER

Misty DeLong
 (304) 558-8802
 misty.m.delong@wv.gov

Signature *[Handwritten Signature]*

FEIN # 550719851

DATE 3-17-15

All offers subject to all terms and conditions contained in this solicitation

		SHIP TO	
ALL STATE AGENCIES VARIOUS LOCATIONS AS INDICATED BY ORDER		STATE OF WEST VIRGINIA VARIOUS LOCATIONS AS INDICATED BY ORDER	
No City	WV99999	No City	WV 99999
US		US	

Line	Comm Ln Desc	Qty	Unit Issue	Unit Price	Total Price
1	STAND PORTION	600.00000	EA	72.11	43,266.00

Comm Code	Manufacturer	Specification	Model #
55121908			C-801-L-KLSH

Extended Description :
STAND PORTION
COMPACT PORTABLE SIGN STAND

		SHIP TO	
ALL STATE AGENCIES VARIOUS LOCATIONS AS INDICATED BY ORDER		STATE OF WEST VIRGINIA VARIOUS LOCATIONS AS INDICATED BY ORDER	
No City	WV99999	No City	WV 99999
US		US	

Line	Comm Ln Desc	Qty	Unit Issue	Unit Price	Total Price
2	STAND PORTION	50.00000	EA	98.23	4911.50

Comm Code	Manufacturer	Specification	Model #
55121908			X-553-DD

Extended Description :
STAND PORTION
LARGE, ALUMINUM SUBSTRATE SIGN AND OVERSIZED ROLL-UP SIGN PORTABLE SIGN STAND

		SHIP TO	
ALL STATE AGENCIES VARIOUS LOCATIONS AS INDICATED BY ORDER		STATE OF WEST VIRGINIA VARIOUS LOCATIONS AS INDICATED BY ORDER	
No City	WV99999	No City	WV 99999
US		US	

Line	Comm Ln Desc	Qty	Unit Issue	Unit Price	Total Price
3	SIGN PORTION	1.00000	EA	78.94	78.94

Comm Code	Manufacturer	Specification	Model #
55121710			

Extended Description :
SIGN PORTION

36" R1-1F "STOP"SIGN

INVOICE TO	SHIP TO
ALL STATE AGENCIES VARIOUS LOCATIONS AS INDICATED BY ORDER	STATE OF WEST VIRGINIA VARIOUS LOCATIONS AS INDICATED BY ORDER
No City US	No City US
WV99999	WV 99999

Line	Comm Ln Desc	Qty	Unit Issue	Unit Price	Total Price
4	SIGN PORTION	5.00000	EA	131.29	656.45

Comm Code	Manufacturer	Specification	Model #
55121710			

Extended Description :
SIGN PORTION

48" R1-1F "STOP"SIGN

INVOICE TO	SHIP TO
ALL STATE AGENCIES VARIOUS LOCATIONS AS INDICATED BY ORDER	STATE OF WEST VIRGINIA VARIOUS LOCATIONS AS INDICATED BY ORDER
No City US	No City US
WV99999	WV 99999

Line	Comm Ln Desc	Qty	Unit Issue	Unit Price	Total Price
5	SIGN PORTION	1.00000	EA	86.12	86.12

Comm Code	Manufacturer	Specification	Model #
55121710			

Extended Description :
SIGN PORTION

36" W3-1MF SYMBOLIC "STOP AHEAD" SIGN

		SHIP TO	
ALL STATE AGENCIES VARIOUS LOCATIONS AS INDICATED BY ORDER		STATE OF WEST VIRGINIA VARIOUS LOCATIONS AS INDICATED BY ORDER	
No City	WV99999	No City	WV 99999
US		US	

Line	Comm Ln Desc	Qty	Unit Issue	Unit Price	Total Price
6	SIGN PORTION	5.00000	EA	134.73	673.65

Comm Code	Manufacturer	Specification	Model #
55121710			

Extended Description :

SIGN PORTION

48" W3-1MF SYMBOLIC "STOP AHEAD" SIGN

		SHIP TO	
ALL STATE AGENCIES VARIOUS LOCATIONS AS INDICATED BY ORDER		STATE OF WEST VIRGINIA VARIOUS LOCATIONS AS INDICATED BY ORDER	
No City	WV99999	No City	WV 99999
US		US	

Line	Comm Ln Desc	Qty	Unit Issue	Unit Price	Total Price
7	SIGN PORTION	1.00000	EA	61.88	61.88

Comm Code	Manufacturer	Specification	Model #
55121710			

Extended Description :

SIGN PORTION

36" R1-2F "YIELD" SIGN

		SHIP TO	
ALL STATE AGENCIES VARIOUS LOCATIONS AS INDICATED BY ORDER		STATE OF WEST VIRGINIA VARIOUS LOCATIONS AS INDICATED BY ORDER	
No City	WV99999	No City	WV 99999
US		US	

Line	Comm Ln Desc	Qty	Unit Issue	Unit Price	Total Price
8	SIGN PORTION	30.00000	EA	114.64	3439.20

Comm Code	Manufacturer	Specification	Model #
55121710			

Extended Description :

SIGN PORTION

48" R1-2F "YIELD" SIGN

INVOICE TO		SHIP TO	
ALL STATE AGENCIES VARIOUS LOCATIONS AS INDICATED BY ORDER		STATE OF WEST VIRGINIA VARIOUS LOCATIONS AS INDICATED BY ORDER	
No City	WV99999	No City	WV 99999
US		US	

Line	Comm Ln Desc	Qty	Unit Issue	Unit Price	Total Price
9	SIGN PORTION	1.00000	EA	86.12	86.12

Comm Code	Manufacturer	Specification	Model #
55121710			

Extended Description :

SIGN PORTION

36" W3-2MF SYMBOLIC "YEILD AHEAD" SIGN

INVOICE TO		SHIP TO	
ALL STATE AGENCIES VARIOUS LOCATIONS AS INDICATED BY ORDER		STATE OF WEST VIRGINIA VARIOUS LOCATIONS AS INDICATED BY ORDER	
No City	WV99999	No City	WV 99999
US		US	

Line	Comm Ln Desc	Qty	Unit Issue	Unit Price	Total Price
10	SIGN PORTION	5.00000	EA	134.72	673.60

Comm Code	Manufacturer	Specification	Model #
55121710			

Extended Description :

SIGN PORTION

48" W3-2MF SYMBOLIC "YEILD AHEAD" SIGN

TO		SHIP TO	
ALL STATE AGENCIES VARIOUS LOCATIONS AS INDICATED BY ORDER		STATE OF WEST VIRGINIA VARIOUS LOCATIONS AS INDICATED BY ORDER	
No City	WV99999	No City	WV 99999
US		US	

Line	Comm Ln Desc	Qty	Unit Issue	Unit Price	Total Price
11	SIGN PORTION	10.00000	EA	110.51	1105.10

Comm Code	Manufacturer	Specification	Model #
55121710			

Extended Description :
SIGN PORTION

36" X 60" R2-1MF "WORK ZONE SPEED LIMIT ____" WITH HOOK AND LOOP FOR NUMERAL OVERLAY PLAQUES (ORDER NUMERALS UNDER ITEM #12)

TO		SHIP TO	
ALL STATE AGENCIES VARIOUS LOCATIONS AS INDICATED BY ORDER		STATE OF WEST VIRGINIA VARIOUS LOCATIONS AS INDICATED BY ORDER	
No City	WV99999	No City	WV 99999
US		US	

Line	Comm Ln Desc	Qty	Unit Issue	Unit Price	Total Price
12	SIGN PORTION	1.00000	EA	14.63	14.63

Comm Code	Manufacturer	Specification	Model #
55121710			

Extended Description :
SIGN PORTION

14" X17" NUMERAL OVERLAY PLAQUES FOR ITEM NUMBER 11 (SPECIFY QUANTITY OF EACH INDIVIDUAL NUMERAL TO BE SUPPLIED)

INVOICE TO		SHIP TO	
ALL STATE AGENCIES VARIOUS LOCATIONS AS INDICATED BY ORDER		STATE OF WEST VIRGINIA VARIOUS LOCATIONS AS INDICATED BY ORDER	
No City	WV99999	No City	WV 99999
US		US	

Line	Comm Ln Desc	Qty	Unit Issue	Unit Price	Total Price
13	SIGN PORTION	10.00000	EA	61.09	610.90

Comm Code	Manufacturer	Specification	Model #
55121710			

Extended Description :

SIGN PORTION

48" x 24" R4-14(L/R) "ALL TRAFFIC (WITH INTERCHANGEABLE ARROW HEAD)"

INVOICE TO		SHIP TO	
ALL STATE AGENCIES VARIOUS LOCATIONS AS INDICATED BY ORDER		STATE OF WEST VIRGINIA VARIOUS LOCATIONS AS INDICATED BY ORDER	
No City	WV99999	No City	WV 99999
US		US	

Line	Comm Ln Desc	Qty	Unit Issue	Unit Price	Total Price
14	SIGN PORTION	1.00000	EA	47.65	47.65

Comm Code	Manufacturer	Specification	Model #
55121710			

Extended Description :

SIGN PORTION

24" x 30" R4-7BF "KEEP RIGHT" SIGN

INVOICE TO		SHIP TO	
ALL STATE AGENCIES VARIOUS LOCATIONS AS INDICATED BY ORDER		STATE OF WEST VIRGINIA VARIOUS LOCATIONS AS INDICATED BY ORDER	
No City	WV99999	No City	WV 99999
US		US	

Line	Comm Ln Desc	Qty	Unit Issue	Unit Price	Total Price
15	SIGN PORTION	1.00000	EA	75.57	75.57

Comm Code	Manufacturer	Specification	Model #
55121710			

Extended Description :

SIGN PORTION

36" x 48" R4-7BF "KEEP RIGHT" SIGN

		SHIP TO	
ALL STATE AGENCIES VARIOUS LOCATIONS AS INDICATED BY ORDER		STATE OF WEST VIRGINIA VARIOUS LOCATIONS AS INDICATED BY ORDER	
No City	WV99999	No City	WV 99999
US		US	

Line	Comm Ln Desc	Qty	Unit Issue	Unit Price	Total Price
16	SIGN PORTION	1.00000	EA	45.24	45.24

Comm Code	Manufacturer	Specification	Model #
55121710			

Extended Description :

SIGN PORTION

30" x 18" R9-9F "SIDEWALK CLOSED"

		SHIP TO	
ALL STATE AGENCIES VARIOUS LOCATIONS AS INDICATED BY ORDER		STATE OF WEST VIRGINIA VARIOUS LOCATIONS AS INDICATED BY ORDER	
No City	WV99999	No City	WV 99999
US		US	

Line	Comm Ln Desc	Qty	Unit Issue	Unit Price	Total Price
17	SIGN PORTION	50.00000	EA	67.70	3385.00

Comm Code	Manufacturer	Specification	Model #
55121710			

Extended Description :

SIGN PORTION

48" X30" R11- 2F "ROAD CLOSED" WITH HOOK AND LOOP FOR OVERLAY PLAQUES (ORDER "BRIDGE" AND "RAMP" OVERLAYS UNDER ITEM #18)

		SHIP TO	
ALL STATE AGENCIES VARIOUS LOCATIONS AS INDICATED BY ORDER		STATE OF WEST VIRGINIA VARIOUS LOCATIONS AS INDICATED BY ORDER	
No City	WV99999	No City	WV 99999
US		US	

Line	Comm Ln Desc	Qty	Unit Issue	Unit Price	Total Price
18	SIGN PORTION	50.00000	EA	18.29	914.50

Comm Code	Manufacturer	Specification	Model #
55121710			

Extended Description :

SIGN PORTION

10" X39" "BRIDGE" AND "RAMP" OVERLAY PLAQUES FOR ITEM 17 (SPECIFY QUANTITY OF EACH INDIVIDUAL PLAQUE TO BE SUPPLIED)

INVOICE TO		SHIP TO	
ALL STATE AGENCIES VARIOUS LOCATIONS AS INDICATED BY ORDER		STATE OF WEST VIRGINIA VARIOUS LOCATIONS AS INDICATED BY ORDER	
No City	WV99999	No City	WV 99999
US		US	

Line	Comm Ln Desc	Qty	Unit Issue	Unit Price	Total Price
19	SIGN PORTION	10.00000	EA	79.96	799.60

Comm Code	Manufacturer	Specification	Model #
55121710			

Extended Description :

SIGN PORTION

60" X 30" R11-3AF "ROAD CLOSED _____ MI AHEAD LOCAL TRAFFIC ONLY" WITH HOOK AND LOOP FOR NUMERAL OVERLAY PLAQUES (ORDER NUMERALS UNDER ITEM #20)

INVOICE TO		SHIP TO	
ALL STATE AGENCIES VARIOUS LOCATIONS AS INDICATED BY ORDER		STATE OF WEST VIRGINIA VARIOUS LOCATIONS AS INDICATED BY ORDER	
No City	WV99999	No City	WV 99999
US		US	

Line	Comm Ln Desc	Qty	Unit Issue	Unit Price	Total Price
20	SIGN PORTION	40.00000	EA	7.32	292.80

Comm Code	Manufacturer	Specification	Model #
55121710			

Extended Description :

SIGN PORTION

5" X 7" NUMERAL OVERLAY PLAQUES FOR ITEM NUMBER 19 (SPECIFY QUANTITY OF EACH INDIVIDUAL NUMERAL TO BE SUPPLIED.)

INVOICE TO		SHIP TO	
ALL STATE AGENCIES VARIOUS LOCATIONS AS INDICATED BY ORDER		STATE OF WEST VIRGINIA VARIOUS LOCATIONS AS INDICATED BY ORDER	
No City	WV99999	No City	WV 99999
US		US	

Line	Comm Ln Desc	Qty	Unit Issue	Unit Price	Total Price
21	SIGN PORTION	10.00000	EA	82.05	820.50

Comm Code	Manufacturer	Specification	Model #
55121710			

Extended Description :
SIGN PORTION

60" X 30" R11-4F "ROAD CLOSED TO THRU TRAFFIC"

INVOICE TO		SHIP TO	
ALL STATE AGENCIES VARIOUS LOCATIONS AS INDICATED BY ORDER		STATE OF WEST VIRGINIA VARIOUS LOCATIONS AS INDICATED BY ORDER	
No City	WV99999	No City	WV 99999
US		US	

Line	Comm Ln Desc	Qty	Unit Issue	Unit Price	Total Price
22	SIGN PORTION	1.00000	EA	89.35	89.35

Comm Code	Manufacturer	Specification	Model #
55121710			

Extended Description :
SIGN PORTION

48" X 36" W22-10F "EXIT _____" WITH HOOK AND LOOP FOR OVERLAYS (ORDER "OPEN" AND "CLOSED" PLAQUES UNDER ITEM #23)

INVOICE TO		SHIP TO	
ALL STATE AGENCIES VARIOUS LOCATIONS AS INDICATED BY ORDER		STATE OF WEST VIRGINIA VARIOUS LOCATIONS AS INDICATED BY ORDER	
No City	WV99999	No City	WV 99999
US		US	

Line	Comm Ln Desc	Qty	Unit Issue	Unit Price	Total Price
23	SIGN PORTION	1.00000	EA	15.90	15.90

Comm Code	Manufacturer	Specification	Model #
55121710			

Extended Description :

SIGN PORTION

10" X 40" "OPEN" AND "CLOSED" OVERLAY PLAQUES FOR ITEM 22 (SPECIFY QUANTITY OF EACH INDIVIDUAL PLAQUE TO BE SUPPLIED)

INVOICE TO		SHIP TO	
ALL STATE AGENCIES VARIOUS LOCATIONS AS INDICATED BY ORDER		STATE OF WEST VIRGINIA VARIOUS LOCATIONS AS INDICATED BY ORDER	
No City	WV99999	No City	WV 99999
US		US	

Line	Comm Ln Desc	Qty	Unit Issue	Unit Price	Total Price
24	SIGN PORTION	1.00000	EA	189.15	189.15

Comm Code	Manufacturer	Specification	Model #
55121710			

Extended Description :

SIGN PORTION

60" x 60" W22-11F EXIT GORE SIGN

INVOICE TO		SHIP TO	
ALL STATE AGENCIES VARIOUS LOCATIONS AS INDICATED BY ORDER		STATE OF WEST VIRGINIA VARIOUS LOCATIONS AS INDICATED BY ORDER	
No City	WV99999	No City	WV 99999
US		US	

Line	Comm Ln Desc	Qty	Unit Issue	Unit Price	Total Price
25	SIGN PORTION	1.00000	EA	62.65	62.65

Comm Code	Manufacturer	Specification	Model #
55121710			

Extended Description :

SIGN PORTION

30" X 24" M4-9F STANDARD DETOUR SIGN WITH HOOK AND LOOP AND ARROW OVERLAY PLAQUE

INVOICE TO		SHIP TO	
ALL STATE AGENCIES VARIOUS LOCATIONS AS INDICATED BY ORDER		STATE OF WEST VIRGINIA VARIOUS LOCATIONS AS INDICATED BY ORDER	
No City	WV99999	No City	WV 99999
US		US	

Line	Comm Ln Desc	Qty	Unit Issue	Unit Price	Total Price
26	SIGN PORTION	10.00000	EA	117.04	1170.40

Comm Code	Manufacturer	Specification	Model #
55121710			

Extended Description :
SIGN PORTION

48" X 48" EMERGENCY RESPONSE TRAILER DETOUR SIGN WITH HOOK AND LOOP FOR OVERLAY PLAQUES AND ARROW OVERLAY PLAQUE (ORDER ROUTE AND CARDINAL DIRECTION PLAQUES UNDER ITEM NUMBER 27 AND 28)

INVOICE TO		SHIP TO	
ALL STATE AGENCIES VARIOUS LOCATIONS AS INDICATED BY ORDER		STATE OF WEST VIRGINIA VARIOUS LOCATIONS AS INDICATED BY ORDER	
No City	WV99999	No City	WV 99999
US		US	

Line	Comm Ln Desc	Qty	Unit Issue	Unit Price	Total Price
27	SIGN PORTION	30.00000	EA	15.52	465.60

Comm Code	Manufacturer	Specification	Model #
55121710			

Extended Description :
SIGN PORTION

9" X 28" EMERGENCY RESPONSE TRAILER ROUTE OVERLAY PLAQUE FOR ITEM 26 (SPECIFY EACH INDIVIDUAL ROUTE PLAQUE TO BE SUPPLIED AND QUANTITY OF EACH)

INVOICE TO		SHIP TO	
ALL STATE AGENCIES VARIOUS LOCATIONS AS INDICATED BY ORDER		STATE OF WEST VIRGINIA VARIOUS LOCATIONS AS INDICATED BY ORDER	
No City	WV99999	No City	WV 99999
US		US	

Line	Comm Ln Desc	Qty	Unit Issue	Unit Price	Total Price
28	SIGN PORTION	1.00000	EA	12.80	12.80

Comm Code	Manufacturer	Specification	Model #
55121710			

Extended Description :

SIGN PORTION

9" X 7" EMERGENCY RESONSE TRAILER CARDINAL DIRECTION OVERLAY PLAQUE FOR ITEM 26 (SPECIFY QUANTITY OF EACH "N", "S", "E" AND "W" PLAQUES TO BE SUPPLIED)

INVOICE TO		SHIP TO	
ALL STATE AGENCIES VARIOUS LOCATIONS AS INDICATED BY ORDER		STATE OF WEST VIRGINIA VARIOUS LOCATIONS AS INDICATED BY ORDER	
No City	WV99999	No City	WV 99999
US		US	

Line	Comm Ln Desc	Qty	Unit Issue	Unit Price	Total Price
29	SIGN PORTION	35.00000	EA	96.66	3383.10

Comm Code	Manufacturer	Specification	Model #
55121710			

Extended Description :

SIGN PORTION

48" X 48" DIAMOND, FLUORESCENT ORANGE, STANDARD MESSAGE ROLL-UP SIGN (SPECIFY QUANTITY OF EACH FABRICATION NUMBER TO BE SUPPLIED)

INVOICE TO		SHIP TO	
ALL STATE AGENCIES VARIOUS LOCATIONS AS INDICATED BY ORDER		STATE OF WEST VIRGINIA VARIOUS LOCATIONS AS INDICATED BY ORDER	
No City	WV99999	No City	WV 99999
US		US	

Line	Comm Ln Desc	Qty	Unit Issue	Unit Price	Total Price
30	SIGN PORTION	570.00000	EA	100.65	57,370.50

Comm Code	Manufacturer	Specification	Model #
55121710			

Extended Description :

SIGN PORTION

48" X 48" DIAMOND, FLUORSCENT ORANGE, STANDARD MESSAGE ROLL-UP SIGN, WITH PERMANENT ADDITION OF TWO (2) 18" X 18" VINYL FOLDING FLAGS. (SPECIFY QUANTITY OF EACH FABRICATION NUMBER TO BE SUPPLIED)

		SHIP TO	
ALL STATE AGENCIES VARIOUS LOCATIONS AS INDICATED BY ORDER		STATE OF WEST VIRGINIA VARIOUS LOCATIONS AS INDICATED BY ORDER	
No City	WV99999	No City	WV 99999
US		US	

Line	Comm Ln Desc	Qty	Unit Issue	Unit Price	Total Price
31	SIGN PORTION	640.00000	EA	55.97	35,820.80

Comm Code	Manufacturer	Specification	Model #
55121710			

Extended Description :

SIGN PORTION

36" X 36" DIAMOND, FLUORESCENT ORANGE, STANDARD MESSAGE ROLL-UP SIGN (SPECIFY QUANTITY OF EACH FABRICATION NUMBER TO BE SUPPLIED)

		SHIP TO	
ALL STATE AGENCIES VARIOUS LOCATIONS AS INDICATED BY ORDER		STATE OF WEST VIRGINIA VARIOUS LOCATIONS AS INDICATED BY ORDER	
No City	WV99999	No City	WV 99999
US		US	

Line	Comm Ln Desc	Qty	Unit Issue	Unit Price	Total Price
32	SIGN PORTION	750.00000	EA	62.62	469.65

Comm Code	Manufacturer	Specification	Model #
55121710			

Extended Description :

SIGN PORTION

36" x 36" DIAMOND, FLUORESCENT ORANGE, STANDARD MESSAGE ROLL-UP SIGN, WITH PERMANENT ADDITION OF TWO (2) 18" X 18" VINYL FOLDING FLAGS. (SPECIFY QUANTITY OF EACH FABRICATION NUMBER OF BE SUPPLIED).

		SHIP TO	
ALL STATE AGENCIES VARIOUS LOCATIONS AS INDICATED BY ORDER		STATE OF WEST VIRGINIA VARIOUS LOCATIONS AS INDICATED BY ORDER	
No City	WV99999	No City	WV 99999
US		US	

Line	Comm Ln Desc	Qty	Unit Issue	Unit Price	Total Price
33	SIGN PORTION	85.00000	EA	99.80	8483.00

Comm Code	Manufacturer	Specification	Model #
55121710			

Extended Description :
SIGN PORTION

48" X 48" DIAMOND, FLUORSCENT ORANGE, STANDARD MESSAGE ROLL-UP SIGN WITH HOOK AND LOOP STRIPS FOR OVERLAY ATTACHMENTS (SPECIFY QUANTITY OF EACH FABRICATION NUMBER TO BE SUPPLIED AND PORTION OF TEXT INTENDED TOBE COVERED WITH OVERLAY PLAQUES - ORDER OVERLAY PLAQUES UNDER BID ITEM 37)

INVOICE TO		SHIP TO	
ALL STATE AGENCIES VARIOUS LOCATIONS AS INDICATED BY ORDER		STATE OF WEST VIRGINIA VARIOUS LOCATIONS AS INDICATED BY ORDER	
No City	WV99999	No City	WV 99999
US		US	

Line	Comm Ln Desc	Qty	Unit Issue	Unit Price	Total Price
34	SIGN PORTION	175.00000	EA	103.46	18105.50

Comm Code	Manufacturer	Specification	Model #
55121710			

Extended Description :
SIGN PORTION

48" X 48" DIAMOND, FLUORESCENT ORANGE, STANDARD MESSAGE ROLL-UP SIGN WITH PERMANENT ADDITION OF TWO(2) 18" X 18" VINYL FOLDING FLAGS, AND HOOK AND LOOP STRIPS FOR OVERLAY ATTACHMENTS (SPECIFY QUANTITY OF EACH FABRICATION NUMBER TO BE SUPPLIED AND PORTION OF TEXT INTENDED TO BE COVERED WITH OVERLAY PLAQUES - ORDER OVERLAY PLAQUES UNDER BID ITEM 37)

INVOICE TO		SHIP TO	
ALL STATE AGENCIES VARIOUS LOCATIONS AS INDICATED BY ORDER		STATE OF WEST VIRGINIA VARIOUS LOCATIONS AS INDICATED BY ORDER	
No City	WV99999	No City	WV 99999
US		US	

Line	Comm Ln Desc	Qty	Unit Issue	Unit Price	Total Price
35	SIGN PORTION	1.00000	EA	64.79	64.79

Comm Code	Manufacturer	Specification	Model #
55121710			

Extended Description :
SIGN PORTION

36" X 36" DIAMOND, FLUORESCENT ORANGE, STANDARD MESSAGE ROLL-UP SIGN WITH HOOK AND LOOP STRIPS FOR OVERLAY

ATTACHMENTS (SPECIFY QUANTITY OF EACH FABRICATION NUMBER TO BE SUPPLIED AND PORTION OF TEXT INTENDED TO BE COVERED WITH OVERLAY PLAQUES - ORDER OVERLAY PLAQUES UNDER BID ITEM 38)

INVOICE TO		SHIP TO	
ALL STATE AGENCIES VARIOUS LOCATIONS AS INDICATED BY ORDER		STATE OF WEST VIRGINIA VARIOUS LOCATIONS AS INDICATED BY ORDER	
No City	WV99999	No City	WV 99999
US		US	

Line	Comm Ln Desc	Qty	Unit Issue	Unit Price	Total Price
36	SIGN PORTION	60.00000	EA	69.49	4169.40

Comm Code	Manufacturer	Specification	Model #
55121710			

Extended Description :
SIGN PORTION

36" x 36" DIAMOND, FLUORESCENT ORANGE, STANDARD MESSAGE ROLL-UP SIGN WITH PERMANENT ADDITION OF TWO (2) 18" X 18" VINYL FOLDING FLAGS, AND HOOK AND LOOP STRIPS FOR OVERLAY ATTACHMENTS (SPECIFY QUANTITY OF EACH FABRICATION NUMBER TO BE SUPPLIED AND PORTION OF TEXT INTENDED TO BE COVERED WITH OVERLAY PLAQUES - ORDER OVERLAY PLAQUES UNDER BID ITEM 38)

INVOICE TO		SHIP TO	
ALL STATE AGENCIES VARIOUS LOCATIONS AS INDICATED BY ORDER		STATE OF WEST VIRGINIA VARIOUS LOCATIONS AS INDICATED BY ORDER	
No City	WV99999	No City	WV 99999
US		US	

Line	Comm Ln Desc	Qty	Unit Issue	Unit Price	Total Price
37	SIGN PORTION	310.00000	EA	13.06	4048.60

Comm Code	Manufacturer	Specification	Model #
55121710			

Extended Description :
SIGN PORTION

8" X 21" ("LEFT" AND "CENTER" TEXT ONLY) OR 8" X 28" FLUORESCENT ORANGE OVERLAYS WITH HOOK AND LOOP STRIPS FOR USE WITH ITEM NUMBERS 33 AND 34. EXAMPLES: LEFT, 500FT., 1000FT., 1500FT., 1/2 MILE, AND 1 MILE (SPECIFY QUANTITY OF EACH PLAQUE TO BE SUPPLIED).

		SHIP TO	
ALL STATE AGENCIES VARIOUS LOCATIONS AS INDICATED BY ORDER		STATE OF WEST VIRGINIA VARIOUS LOCATIONS AS INDICATED BY ORDER	
No City	WV99999	No City	WV 99999
US		US	

Line	Comm Ln Desc	Qty	Unit Issue	Unit Price	Total Price
38	SIGN PORTION	10.00000	EA	11.50	115.00

Comm Code	Manufacturer	Specification	Model #
55121710			

Extended Description :
SIGN PORTION

6" X 21" FLUORESCENT ORANGE OVERLAYS WITH HOOK AND LOOP STRIPS FOR USE WITH ITEM NUMBERS 35 AND 36. EXAMPLES: LEFT, 500FT., 1000FT., 1/2 MILE, 1 MILE, AND AHEAD)SPECIFY QUANTITY OF EACH PLAQUE TO BE SUPPLIED)

		SHIP TO	
ALL STATE AGENCIES VARIOUS LOCATIONS AS INDICATED BY ORDER		STATE OF WEST VIRGINIA VARIOUS LOCATIONS AS INDICATED BY ORDER	
No City	WV99999	No City	WV 99999
US		US	

Line	Comm Ln Desc	Qty	Unit Issue	Unit Price	Total Price
39	SIGN PORTION	1.00000	EA	55.67	55.67

Comm Code	Manufacturer	Specification	Model #
55121710			

Extended Description :
SIGN PORTION

18" X 36" G20-2 "END OF ROAD WORK" SIGN

		SHIP TO	
ALL STATE AGENCIES VARIOUS LOCATIONS AS INDICATED BY ORDER		STATE OF WEST VIRGINIA VARIOUS LOCATIONS AS INDICATED BY ORDER	
No City	WV99999	No City	WV 99999
US		US	

INVOICE TO		SHIP TO	
ALL STATE AGENCIES VARIOUS LOCATIONS AS INDICATED BY ORDER		STATE OF WEST VIRGINIA VARIOUS LOCATIONS AS INDICATED BY ORDER	
No City	WV99999	No City	WV 99999
US		US	

Line	Comm Ln Desc	Qty	Unit Issue	Unit Price	Total Price
43	SIGN PORTION	1.00000	EA	77.59	

Comm Code	Manufacturer	Specification	Model #
55121710			

Extended Description :

FLUORESCENT PINK SIGN PORTION

48" W3-2MF SYMBOLIC "YIELD AHEAD" SIGN, FLUORESCENT-PINK

INVOICE TO		SHIP TO	
ALL STATE AGENCIES VARIOUS LOCATIONS AS INDICATED BY ORDER		STATE OF WEST VIRGINIA VARIOUS LOCATIONS AS INDICATED BY ORDER	
No City	WV99999	No City	WV 99999
US		US	

Line	Comm Ln Desc	Qty	Unit Issue	Unit Price	Total Price
44	SIGN PORTION	1.00000	EA	52.52	

Comm Code	Manufacturer	Specification	Model #
55121710			

Extended Description :

FLUORESCENT PINK SIGN PORTION

48"X36" W22-10F "EXIT _____" W /HOOK & LOOP FOR OVERLAYS, FLUORESCENT-PINK (ORDER "OPEN" AND "CLOSED" PLAQUES UNDER ITEM #51)

INVOICE TO		SHIP TO	
ALL STATE AGENCIES VARIOUS LOCATIONS AS INDICATED BY ORDER		STATE OF WEST VIRGINIA VARIOUS LOCATIONS AS INDICATED BY ORDER	
No City	WV99999	No City	WV 99999
US		US	

Line	Comm Ln Desc	Qty	Unit Issue	Unit Price	Total Price
45	SIGN PORTION	1.00000	EA	11.50	11.50

Comm Code	Manufacturer	Specification	Model #
55121710			

Extended Description :

FLUORESCENT PINK SIGN PORTION

10"X40" 'OPEN" AND "CLOSED" OVERLY PLAQUES FOR ITEMS 50, FLUORESCENT-PINK (SPECIFY QTY OF EACH INDIVIDUAL PLAQUE TO BE SUPPLIED)

INVOICE TO		SHIP TO	
ALL STATE AGENCIES VARIOUS LOCATIONS AS INDICATED BY ORDER		STATE OF WEST VIRGINIA VARIOUS LOCATIONS AS INDICATED BY ORDER	
No City	WV99999	No City	WV 99999
US		US	

Line	Comm Ln Desc	Qty	Unit Issue	Unit Price	Total Price
46	SIGN PORTION	1.00000	EA	39.89	39.89

Comm Code	Manufacturer	Specification	Model #
55121710			

Extended Description :

FLUORESCENT PINK SIGN PORTION

30"X24" M4-9F STANDARD DETOUR SIGN W/HOOK & LOOP AND ARROW OVERLAY PLAQUE, FLOURESCENT-PINK

INVOICE TO		SHIP TO	
ALL STATE AGENCIES VARIOUS LOCATIONS AS INDICATED BY ORDER		STATE OF WEST VIRGINIA VARIOUS LOCATIONS AS INDICATED BY ORDER	
No City	WV99999	No City	WV 99999
US		US	

Line	Comm Ln Desc	Qty	Unit Issue	Unit Price	Total Price
47	SIGN PORTION	1.00000	EA	70.28	70.28

Comm Code	Manufacturer	Specification	Model #
55121710			

Extended Description :

48"x 48" EMERGENCY RESPONSE TRAILER DETOUR SIGN W/HOOK & LOOP FOR OVERLAY PLAGUE AND ARROW OVERLAY PLAQUE, FLUORESCENT-PINK(ORDER ROUTE AND CARDINAL DIRECTION PLAQUE UNDER ITEMS NUMBERS 54 & 55)

INVOICE TO		SHIP TO	
ALL STATE AGENCIES VARIOUS LOCATIONS AS INDICATED BY ORDER		STATE OF WEST VIRGINIA VARIOUS LOCATIONS AS INDICATED BY ORDER	
No City	WV99999	No City	WV 99999
US		US	

Line	Comm Ln Desc	Qty	Unit Issue	Unit Price	Total Price
48	SIGN PORTION	1.00000	EA	11.50	11.50

Comm Code	Manufacturer	Specification	Model #
55121710			

Extended Description :
9" X 28" EMERGENCY RESPONSE TRAILER ROUTE OVERLAY PLAQUE FOR ITEM 53, FLUORESCENT-PINK (SPECIFY EACH INDIVIDUAL ROUTE PLAQUE TO BE SUPPLIED AND QTY OF EACH)

INVOICE TO		SHIP TO	
ALL STATE AGENCIES VARIOUS LOCATIONS AS INDICATED BY ORDER		STATE OF WEST VIRGINIA VARIOUS LOCATIONS AS INDICATED BY ORDER	
No City	WV99999	No City	WV 99999
US		US	

Line	Comm Ln Desc	Qty	Unit Issue	Unit Price	Total Price
49	SIGN PORTION	1.00000	EA	8.36	8.36

Comm Code	Manufacturer	Specification	Model #
55121710			

Extended Description :
9" x 7" EMERGENCY RESPONSE TRAILER CARDINAL DIRECTION OVERLAY PLAQUE FOR ITEM 53, FLUORESCENT-PINK (SPECIFY QTY OF EACH "N", "S", "E", AND "W" PLAQUES TO EACH)

INVOICE TO		SHIP TO	
ALL STATE AGENCIES VARIOUS LOCATIONS AS INDICATED BY ORDER		STATE OF WEST VIRGINIA VARIOUS LOCATIONS AS INDICATED BY ORDER	
No City	WV99999	No City	WV 99999
US		US	

Line	Comm Ln Desc	Qty	Unit Issue	Unit Price	Total Price
50	SIGN PORTION	1.00000	EA	67.14	67.14

Comm Code:	Manufacturer	Specification	Model #
55121710			

Extended Description :

48" X48" DIAMOND, FLUORESCENT PINK, STANDARD MESSAGE ROLL-UP SIGN (SPECIFY QUANTITY OF EACH FABRICATION NUMBER TO BE SUPPLIED)

INVOICE TO		SHIP TO	
ALL STATE AGENCIES VARIOUS LOCATIONS AS INDICATED BY ORDER		STATE OF WEST VIRGINIA VARIOUS LOCATIONS AS INDICATED BY ORDER	
No City	WV99999	No City	WV 99999
US		US	

Line	Comm Ln Desc	Qty	Unit Issue	Unit Price	Total Price
51	SIGN PORTION	1.00000	EA	43.51	43.51

Comm Code	Manufacturer	Specification	Model #
55121710			

Extended Description :

36" X36" DIAMOND, FLUORESCENT PINK, STANDARD MESSAGE ROLL-UP SIGN (SPECIFY QUANTITY OF EACH FABRICATION NUMBER TO BE SUPPLIED)

INVOICE TO		SHIP TO	
ALL STATE AGENCIES VARIOUS LOCATIONS AS INDICATED BY ORDER		STATE OF WEST VIRGINIA VARIOUS LOCATIONS AS INDICATED BY ORDER	
No City	WV99999	No City	WV 99999
US		US	

Line	Comm Ln Desc	Qty	Unit Issue	Unit Price	Total Price
52	SIGN PORTION	1.00000	EA	67.14	67.14

Comm Code	Manufacturer	Specification	Model #
55121710			

Extended Description :

48" X48" DIAMOND, FLUORESCENT PINK, STANDARD MESSAGE ROLL-UP SIGN WITH HOOK & LOOP STRIPS FOR OVERLAY ATTACHEMNTS(SPECIFY QUANTITY OF EACH FABRICATION NUMBER TO BE SUPPLIED AQND PORTION OF TEXT INTENDED TO BE COVERED WITH OVERLAY PLAQUES- ODER OVERLAY PLAQUES UNDER BID ITEM 54)

Line	Comm Ln Desc	Qty	Unit Issue	Unit Price	Total Price
55'	SIGN PORTION	1.00000	EA	8.36	8.36

Comm Code	Manufacturer	Specification	Model #
55121710			

Extended Description :

6" x 21" FLUORESCENT PINK OVERLAYS WITH HOOK & LOOP STRIPS FOR USE WITH ITEM NUMBER 53. EXAMPLES: LEFT, 500FT., 1000FT., 1500., 1/2 MILE., 1 MILE, AND AHEAD (SPECIFY QUANTITY OF EACH PLAQUE TO BE SUPPLIED)

DOT1500000059	Document Phase Draft	Document Description PORTABLE SIGN STANDS AND REFLE CTIVE ROLL-UP SIGNS	Page 25 of 25
----------------------	--------------------------------	--	--

ADDITIONAL TERMS AND CONDITIONS

See attached document(s) for additional Terms and Conditions

INSTRUCTIONS TO VENDORS SUBMITTING BIDS

1. **REVIEW DOCUMENTS THOROUGHLY:** The attached documents contain a solicitation for bids. Please read these instructions and all documents attached in their entirety. These instructions provide critical information about requirements that if overlooked could lead to disqualification of a Vendor's bid. All bids must be submitted in accordance with the provisions contained in these instructions and the Solicitation. Failure to do so may result in disqualification of Vendor's bid.
2. **MANDATORY TERMS:** The Solicitation may contain mandatory provisions identified by the use of the words "must," "will," and "shall." Failure to comply with a mandatory term in the Solicitation will result in bid disqualification.
3. **PREBID MEETING:** The item identified below shall apply to this Solicitation.

A pre-bid meeting will not be held prior to bid opening.

A NON-MANDATORY PRE-BID meeting will be held at the following place and time:

A MANDATORY PRE-BID meeting will be held at the following place and time:

All Vendors submitting a bid must attend the mandatory pre-bid meeting. Failure to attend the mandatory pre-bid meeting shall result in disqualification of the Vendor's bid. No one person attending the pre-bid meeting may represent more than one Vendor.

An attendance sheet provided at the pre-bid meeting shall serve as the official document verifying attendance. The State will not accept any other form of proof or documentation to verify attendance. Any person attending the pre-bid meeting on behalf of a Vendor must list on the attendance sheet his or her name and the name of the Vendor he or she is representing. Additionally, the person attending the pre-bid meeting should include the Vendor's E-Mail address, phone number, and Fax number on the attendance sheet. It is the Vendor's responsibility to locate the attendance sheet and provide the required information. Failure to complete the attendance sheet as required may result in disqualification of Vendor's bid.

All Vendors should arrive prior to the starting time for the pre-bid. Vendors who arrive after the starting time but prior to the end of the pre-bid will be permitted to sign in, but are charged with knowing all matters discussed at the pre-bid.

Questions submitted at least five business days prior to a scheduled pre-bid will be discussed at the pre-bid meeting if possible. Any discussions or answers to questions at the pre-bid meeting are preliminary in nature and are non-binding. Official and binding answers to questions will be published in a written addendum to the Solicitation prior to bid opening.

4. **VENDOR QUESTION DEADLINE:** Vendors may submit questions relating to this Solicitation to the Purchasing Division. Questions must be submitted in writing. All questions must be submitted on or before the date listed below and to the address listed below in order to be considered. A written response will be published in a Solicitation addendum if a response is possible and appropriate. Non-written discussions, conversations, or questions and answers regarding this Solicitation are preliminary in nature and are non-binding. Submitted e-mails should have solicitation number in the subject line.

Question Submission Deadline: March 6, 2015

Submit Questions to: Misty Delong
2019 Washington Street, East
Charleston, WV 25305
Fax: (304) 558-4115 (Vendors should not use this fax number for bid submission)
Email: Misty.M.Delong@wv.gov

5. **VERBAL COMMUNICATION:** Any verbal communication between the Vendor and any State personnel is not binding, including verbal communication at the mandatory pre-bid conference. Only information issued in writing and added to the Solicitation by an official written addendum by the Purchasing Division is binding.
6. **BID SUBMISSION:** All bids must be submitted electronically through wvOASIS or signed and delivered by the Vendor to the Purchasing Division at the address listed below on or before the date and time of the bid opening. Any bid received by the Purchasing Division staff is considered to be in the possession of the Purchasing Division and will not be returned for any reason. The Purchasing Division will not accept bids, modification of bids, or addendum acknowledgment forms via e-mail. Acceptable delivery methods include electronic submission via wvOASIS, hand delivery, delivery by courier, or facsimile. The bid delivery address is:

Department of Administration, Purchasing Division
2019 Washington Street East
Charleston, WV 25305-0130

A bid that is not submitted electronically through wvOASIS should contain the information listed below on the face of the envelope or the bid may be rejected by the Purchasing Division.:

SEALED BID:
BUYER: Misty DeLong
SOLICITATION NO.: CRFQ DOT1500000059
BID OPENING DATE: March 18, 2015
BID OPENING TIME: 1:30 PM EST.
FAX NUMBER: 304-558-3970

In the event that Vendor is responding to a request for proposal, and chooses to respond in a manner other than by electronic submission through wvOASIS, the Vendor shall submit one original technical and one original cost proposal plus NA convenience copies of each to the Purchasing Division at the address shown above. Additionally, if Vendor does not submit its bid through wvOASIS, the Vendor should identify the bid type as either a technical or cost proposal on the face of each bid envelope submitted in response to a request for proposal as follows:

BID TYPE: (This only applies to CRFP)

Technical

Cost

7. **BID OPENING:** Bids submitted in response to this Solicitation will be opened at the location identified below on the date and time listed below. Delivery of a bid after the bid opening date and time will result in bid disqualification. For purposes of this Solicitation, a bid is considered delivered when confirmation of delivery is provided by wvOASIS (in the case of electronic submission) or when the bid is time stamped by the official Purchasing Division time clock (in the case of hand delivery).

March 18, 2015 at 1:30 PM, EST.

Bid Opening Date and Time:
Bid Opening Location: Department of Administration, Purchasing Division
2019 Washington Street East
Charleston, WV 25305-0130

8. **ADDENDUM ACKNOWLEDGEMENT:** Changes or revisions to this Solicitation will be made by an official written addendum issued by the Purchasing Division. Vendor should acknowledge receipt of all addenda issued with this Solicitation by completing an Addendum Acknowledgment Form, a copy of which is included herewith. Failure to acknowledge addenda may result in bid disqualification. The addendum acknowledgement should be submitted with the bid to expedite document processing.

9. **BID FORMATTING:** Vendor should type or electronically enter the information onto its bid to prevent errors in the evaluation. Failure to type or electronically enter the information may result in bid disqualification.
10. **ALTERNATES:** Any model, brand, or specification listed in this Solicitation establishes the acceptable level of quality only and is not intended to reflect a preference for, or in any way favor, a particular brand or vendor. Vendors may bid alternates to a listed model or brand provided that the alternate is at least equal to the model or brand and complies with the required specifications. The equality of any alternate being bid shall be determined by the State at its sole discretion. Any Vendor bidding an alternate model or brand should clearly identify the alternate items in its bid and should include manufacturer's specifications, industry literature, and/or any other relevant documentation demonstrating the equality of the alternate items. Failure to provide information for alternate items may be grounds for rejection of a Vendor's bid.
11. **EXCEPTIONS AND CLARIFICATIONS:** The Solicitation contains the specifications that shall form the basis of a contractual agreement. Vendor shall clearly mark any exceptions, clarifications, or other proposed modifications in its bid. Exceptions to, clarifications of, or modifications of a requirement or term and condition of the Solicitation may result in bid disqualification.
12. **COMMUNICATION LIMITATIONS:** In accordance with West Virginia Code of State Rules §148-1-6.6, communication with the State of West Virginia or any of its employees regarding this Solicitation during the solicitation, bid, evaluation or award periods, except through the Purchasing Division, is strictly prohibited without prior Purchasing Division approval. Purchasing Division approval for such communication is implied for all agency delegated and exempt purchases.
13. **REGISTRATION:** Prior to Contract award, the apparent successful Vendor must be properly registered with the West Virginia Purchasing Division and must have paid the \$125 fee, if applicable.
14. **UNIT PRICE:** Unit prices shall prevail in cases of a discrepancy in the Vendor's bid.
15. **PREFERENCE:** Vendor Preference may only be granted upon written request and only in accordance with the West Virginia Code § 5A-3-37 and the West Virginia Code of State Rules. A Vendor Preference Certificate form has been attached hereto to allow Vendor to apply for the preference. Vendor's failure to submit the Vendor Preference Certificate form with its bid will result in denial of Vendor Preference. Vendor Preference does not apply to construction projects.
16. **SMALL, WOMEN-OWNED, OR MINORITY-OWNED BUSINESSES:** For any solicitations publicly advertised for bid, in accordance with West Virginia Code §5A-3-37(a)(7) and W. Va. CSR § 148-22-9, any non-resident vendor certified as a small, women-owned, or minority-owned business under W. Va. CSR § 148-22-9 shall be provided the

same preference made available to any resident vendor. Any non-resident small, women-owned, or minority-owned business must identify itself as such in writing, must submit that writing to the Purchasing Division with its bid, and must be properly certified under W. Va. CSR § 148-22-9 prior to contract award to receive the preferences made available to resident vendors. Preference for a non-resident small, women-owned, or minority owned business shall be applied in accordance with W. Va. CSR § 148-22-9.

17. WAIVER OF MINOR IRREGULARITIES: The Director reserves the right to waive minor irregularities in bids or specifications in accordance with West Virginia Code of State Rules § 148-1-4.6.

GENERAL TERMS AND CONDITIONS:

1. **CONTRACTUAL AGREEMENT:** Issuance of a Award Document signed by the Purchasing Division Director, or his designee, and approved as to form by the Attorney General's office constitutes acceptance of this Contract made by and between the State of West Virginia and the Vendor. Vendor's signature on its bid signifies Vendor's agreement to be bound by and accept the terms and conditions contained in this Contract.

2. **DEFINITIONS:** As used in this Solicitation/Contract, the following terms shall have the meanings attributed to them below. Additional definitions may be found in the specifications included with this Solicitation/Contract.
 - 2.1. **"Agency" or "Agencies"** means the agency, board, commission, or other entity of the State of West Virginia that is identified on the first page of the Solicitation or any other public entity seeking to procure goods or services under this Contract.

 - 2.2. **"Contract"** means the binding agreement that is entered into between the State and the Vendor to provide the goods or services requested in the Solicitation.

 - 2.3. **"Director"** means the Director of the West Virginia Department of Administration, Purchasing Division.

 - 2.4. **"Purchasing Division"** means the West Virginia Department of Administration, Purchasing Division.

 - 2.5. **"Award Document"** means the document signed by the Agency and the Purchasing Division, and approved as to form by the Attorney General, that identifies the Vendor as the contract holder.

 - 2.6. **"Solicitation"** means the official notice of an opportunity to supply the State with goods or services that is published by the Purchasing Division.

 - 2.7. **"State"** means the State of West Virginia and/or any of its agencies, commissions, boards, etc. as context requires.

 - 2.8. **"Vendor" or "Vendors"** means any entity submitting a bid in response to the Solicitation, the entity that has been selected as the lowest responsible bidder, or the entity that has been awarded the Contract as context requires.

3. **CONTRACT TERM; RENEWAL; EXTENSION:** The term of this Contract shall be determined in accordance with the category that has been identified as applicable to this Contract below:

Term Contract

Initial Contract Term: This Contract becomes effective on UPON AWARD and extends for a period of one (1) year(s).

Renewal Term: This Contract may be renewed upon the mutual written consent of the Agency, and the Vendor, with approval of the Purchasing Division and the Attorney General's office (Attorney General approval is as to form only). Any request for renewal should be submitted to the Purchasing Division thirty (30) days prior to the expiration date of the initial contract term or appropriate renewal term. A Contract renewal shall be in accordance with the terms and conditions of the original contract. Renewal of this Contract is limited to 3 (Three) successive one (1) year periods or multiple renewal periods of less than one year, provided that the multiple renewal periods do not exceed 36 months in total. Automatic renewal of this Contract is prohibited. Notwithstanding the foregoing, Purchasing Division approval is not required on agency delegated or exempt purchases. Attorney General approval may be required for vendor terms and conditions.

Delivery Order Limitations: In the event that this contract permits delivery orders, a delivery order may only be issued during the time this Contract is in effect. Any delivery order issued within one year of the expiration of this Contract shall be effective for one year from the date the delivery order is issued. No delivery order may be extended beyond one year after this Contract has expired.

Fixed Period Contract: This Contract becomes effective upon Vendor's receipt of the notice to proceed and must be completed within _____ days.

Fixed Period Contract with Renewals: This Contract becomes effective upon Vendor's receipt of the notice to proceed and part of the Contract more fully described in the attached specifications must be completed within _____ days. Upon completion, the vendor agrees that maintenance, monitoring, or warranty services will be provided for one year thereafter with an additional _____ successive one year renewal periods or multiple renewal periods of less than one year provided that the multiple renewal periods do not exceed _____ months in total. Automatic renewal of this Contract is prohibited.

One Time Purchase: The term of this Contract shall run from the issuance of the Award Document until all of the goods contracted for have been delivered, but in no event will this Contract extend for more than one fiscal year.

Other: See attached.

4. **NOTICE TO PROCEED:** Vendor shall begin performance of this Contract immediately upon receiving notice to proceed unless otherwise instructed by the Agency. Unless otherwise specified, the fully executed Award Document will be considered notice to proceed.
5. **QUANTITIES:** The quantities required under this Contract shall be determined in accordance with the category that has been identified as applicable to this Contract below.
 - Open End Contract:** Quantities listed in this Solicitation are approximations only, based on estimates supplied by the Agency. It is understood and agreed that the Contract shall cover the quantities actually ordered for delivery during the term of the Contract, whether more or less than the quantities shown.
 - Service:** The scope of the service to be provided will be more clearly defined in the specifications included herewith.
 - Combined Service and Goods:** The scope of the service and deliverable goods to be provided will be more clearly defined in the specifications included herewith.
 - One Time Purchase:** This Contract is for the purchase of a set quantity of goods that are identified in the specifications included herewith. Once those items have been delivered, no additional goods may be procured under this Contract without an appropriate change order approved by the Vendor, Agency, Purchasing Division, and Attorney General's office.
6. **PRICING:** The pricing set forth herein is firm for the life of the Contract, unless specified elsewhere within this Solicitation/Contract by the State. A Vendor's inclusion of price adjustment provisions in its bid, without an express authorization from the State in the Solicitation to do so, may result in bid disqualification.
7. **EMERGENCY PURCHASES:** The Purchasing Division Director may authorize the Agency to purchase goods or services in the open market that Vendor would otherwise provide under this Contract if those goods or services are for immediate or expedited delivery in an emergency. Emergencies shall include, but are not limited to, delays in transportation or an unanticipated increase in the volume of work. An emergency purchase in the open market, approved by the Purchasing Division Director, shall not constitute a breach of this Contract and shall not entitle the Vendor to any form of compensation or damages. This provision does not excuse the State from fulfilling its obligations under a One Time Purchase contract.
8. **REQUIRED DOCUMENTS:** All of the items checked below must be provided to the Purchasing Division by the Vendor as specified below.

BID BOND: All Vendors shall furnish a bid bond in the amount of five percent (5%) of the total amount of the bid protecting the State of West Virginia. The bid bond must be submitted with the bid.

PERFORMANCE BOND: The apparent successful Vendor shall provide a performance bond in the amount of _____. The performance bond must be received by the Purchasing Division prior to Contract award. On construction contracts, the performance bond must be 100% of the Contract value.

LABOR/MATERIAL PAYMENT BOND: The apparent successful Vendor shall provide a labor/material payment bond in the amount of 100% of the Contract value. The labor/material payment bond must be delivered to the Purchasing Division prior to Contract award.

In lieu of the Bid Bond, Performance Bond, and Labor/Material Payment Bond, the Vendor may provide certified checks, cashier's checks, or irrevocable letters of credit. Any certified check, cashier's check, or irrevocable letter of credit provided in lieu of a bond must be of the same amount and delivered on the same schedule as the bond it replaces. A letter of credit submitted in lieu of a performance and labor/material payment bond will only be allowed for projects under \$100,000. Personal or business checks are not acceptable.

MAINTENANCE BOND: The apparent successful Vendor shall provide a two (2) year maintenance bond covering the roofing system. The maintenance bond must be issued and delivered to the Purchasing Division prior to Contract award.

INSURANCE: The apparent successful Vendor shall furnish proof of the following insurance prior to Contract award and shall list the state as a certificate holder:

Commercial General Liability Insurance: In the amount of _____ or more.

Builders Risk Insurance: In an amount equal to 100% of the amount of the Contract.

The apparent successful Vendor shall also furnish proof of any additional insurance requirements contained in the specifications prior to Contract award regardless of whether or not that insurance requirement is listed above.

LICENSE(S) / CERTIFICATIONS / PERMITS: In addition to anything required under the Section entitled Licensing, of the General Terms and Conditions, the apparent successful Vendor shall furnish proof of the following licenses, certifications, and/or permits prior to Contract award, in a form acceptable to the Purchasing Division.

The apparent successful Vendor shall also furnish proof of any additional licenses or certifications contained in the specifications prior to Contract award regardless of whether or not that requirement is listed above.

9. WORKERS' COMPENSATION INSURANCE: The apparent successful Vendor shall comply with laws relating to workers compensation, shall maintain workers' compensation insurance when required, and shall furnish proof of workers' compensation insurance upon request.

10. LITIGATION BOND: The Director reserves the right to require any Vendor that files a protest of an award to submit a litigation bond in the amount equal to one percent of the lowest bid submitted or \$5,000, whichever is greater. The entire amount of the bond shall be forfeited if the hearing officer determines that the protest was filed for frivolous or improper purpose, including but not limited to, the purpose of harassing, causing unnecessary delay, or needless expense for the Agency. All litigation bonds shall be made payable to the Purchasing Division. In lieu of a bond, the protester may submit a cashier's check or certified check payable to the Purchasing Division. Cashier's or certified checks will be deposited with and held by the State Treasurer's office. If it is determined that the protest has not been filed for frivolous or improper purpose, the bond or deposit shall be returned in its entirety.

11. LIQUIDATED DAMAGES: Vendor shall pay liquidated damages in the amount of

NA
for _____
NA

This clause shall in no way be considered exclusive and shall not limit the State or Agency's right to pursue any other available remedy.

- 12. ACCEPTANCE/REJECTION:** The State may accept or reject any bid in whole, or in part. Vendor's signature on its bid signifies acceptance of the terms and conditions contained in the Solicitation and Vendor agrees to be bound by the terms of the Contract, as reflected in the Award Document, upon receipt.
- 13. FUNDING:** This Contract shall continue for the term stated herein, contingent upon funds being appropriated by the Legislature or otherwise being made available. In the event funds are not appropriated or otherwise made available, this Contract becomes void and of no effect beginning on July 1 of the fiscal year for which funding has not been appropriated or otherwise made available.
- 14. PAYMENT:** Payment in advance is prohibited under this Contract. Payment may only be made after the delivery and acceptance of goods or services. The Vendor shall submit invoices, in arrears.
- 15. TAXES:** The Vendor shall pay any applicable sales, use, personal property or any other taxes arising out of this Contract and the transactions contemplated thereby. The State of West Virginia is exempt from federal and state taxes and will not pay or reimburse such taxes.
- 16. CANCELLATION:** The Purchasing Division Director reserves the right to cancel this Contract immediately upon written notice to the vendor if the materials or workmanship supplied do not conform to the specifications contained in the Contract. The Purchasing Division Director may also cancel any purchase or Contract upon 30 days written notice to the Vendor in accordance with West Virginia Code of State Rules § 148-1-7.16.2.
- 17. TIME:** Time is of the essence with regard to all matters of time and performance in this Contract.
- 18. APPLICABLE LAW:** This Contract is governed by and interpreted under West Virginia law without giving effect to its choice of law principles. Any information provided in specification manuals, or any other source, verbal or written, which contradicts or violates the West Virginia Constitution, West Virginia Code or West Virginia Code of State Rules is void and of no effect.
- 19. COMPLIANCE:** Vendor shall comply with all applicable federal, state, and local laws, regulations and ordinances. By submitting a bid, Vendor acknowledges that it has reviewed, understands, and will comply with all applicable law.
- 20. PREVAILING WAGE:** On any contract for the construction of a public improvement, Vendor and any subcontractors utilized by Vendor shall pay a rate or rates of wages which shall not be less than the fair minimum rate or rates of wages (prevailing wage), as established by the West Virginia Division of Labor under West Virginia Code §§ 21-5A-1 et seq. and available at <http://www.sos.wv.gov/administrative-law/wagerates/Pages/default.aspx>. Vendor shall be responsible for ensuring compliance with

prevailing wage requirements and determining when prevailing wage requirements are applicable. The required contract provisions contained in West Virginia Code of State Rules § 42-7-3 are specifically incorporated herein by reference.

- 21. ARBITRATION:** Any references made to arbitration contained in this Contract, Vendor's bid, or in any American Institute of Architects documents pertaining to this Contract are hereby deleted, void, and of no effect.
- 22. MODIFICATIONS:** This writing is the parties' final expression of intent. Notwithstanding anything contained in this Contract to the contrary, no modification of this Contract shall be binding without mutual written consent of the Agency, and the Vendor, with approval of the Purchasing Division and the Attorney General's office (Attorney General approval is as to form only). No Change shall be implemented by the Vendor until such time as the Vendor receives an approved written change order from the Purchasing Division.
- 23. WAIVER:** The failure of either party to insist upon a strict performance of any of the terms or provision of this Contract, or to exercise any option, right, or remedy herein contained, shall not be construed as a waiver or a relinquishment for the future of such term, provision, option, right, or remedy, but the same shall continue in full force and effect. Any waiver must be expressly stated in writing and signed by the waiving party.
- 24. SUBSEQUENT FORMS:** The terms and conditions contained in this Contract shall supersede any and all subsequent terms and conditions which may appear on any form documents submitted by Vendor to the Agency or Purchasing Division such as price lists, order forms, invoices, sales agreements, or maintenance agreements, and includes internet websites or other electronic documents. Acceptance or use of Vendor's forms does not constitute acceptance of the terms and conditions contained thereon.
- 25. ASSIGNMENT:** Neither this Contract nor any monies due, or to become due hereunder, may be assigned by the Vendor without the express written consent of the Agency, the Purchasing Division, the Attorney General's office (as to form only), and any other government agency or office that may be required to approve such assignments. Notwithstanding the foregoing, Purchasing Division approval may or may not be required on certain agency delegated or exempt purchases.
- 26. WARRANTY:** The Vendor expressly warrants that the goods and/or services covered by this Contract will: (a) conform to the specifications, drawings, samples, or other description furnished or specified by the Agency; (b) be merchantable and fit for the purpose intended; and (c) be free from defect in material and workmanship.
- 27. STATE EMPLOYEES:** State employees are not permitted to utilize this Contract for personal use and the Vendor is prohibited from permitting or facilitating the same.
- 28. BANKRUPTCY:** In the event the Vendor files for bankruptcy protection, the State of West Virginia may deem this Contract null and void, and terminate this Contract without notice.

29. CONFIDENTIALITY: The Vendor agrees that it will not disclose to anyone, directly or indirectly, any such personally identifiable information or other confidential information gained from the Agency, unless the individual who is the subject of the information consents to the disclosure in writing or the disclosure is made pursuant to the Agency's policies, procedures, and rules. Vendor further agrees to comply with the Confidentiality Policies and Information Security Accountability Requirements, set forth in <http://www.state.wv.us/admin/purchase/privacy/default.html>.

30. DISCLOSURE: Vendor's response to the Solicitation and the resulting Contract are considered public documents and will be disclosed to the public in accordance with the laws, rules, and policies governing the West Virginia Purchasing Division. Those laws include, but are not limited to, the Freedom of Information Act found in West Virginia Code §§ 29B-1-1 et seq. and the competitive bidding laws found West Virginia Code §§ 5A-3-1 et seq., 5-22-1 et seq., and 5G-1-1 et seq.

If a Vendor considers any part of its bid to be exempt from public disclosure, Vendor must so indicate by specifically identifying the exempt information, identifying the exemption that applies, providing a detailed justification for the exemption, segregating the exempt information from the general bid information, and submitting the exempt information as part of its bid but in a segregated and clearly identifiable format. Failure to comply with the foregoing requirements will result in public disclosure of the Vendor's bid without further notice. A Vendor's act of marking all or nearly all of its bid as exempt is not sufficient to avoid disclosure and WILL NOT BE HONORED. Vendor's act of marking a bid or any part thereof as "confidential" or "proprietary" is not sufficient to avoid disclosure and WILL NOT BE HONORED. A legend or other statement indicating that all or substantially all of the bid is exempt from disclosure is not sufficient to avoid disclosure and WILL NOT BE HONORED. Additionally, pricing or cost information will not be considered exempt from disclosure and requests to withhold publication of pricing or cost information WILL NOT BE HONORED.

Vendor will be required to defend any claimed exemption for nondisclosure in the event of an administrative or judicial challenge to the State's nondisclosure. Vendor must indemnify the State for any costs incurred related to any exemptions claimed by Vendor. Any questions regarding the applicability of the various public records laws should be addressed to your own legal counsel prior to bid submission.

31. LICENSING: In accordance with West Virginia Code of State Rules §148-1-6.1.7, Vendor must be licensed and in good standing in accordance with any and all state and local laws and requirements by any state or local agency of West Virginia, including, but not limited to, the West Virginia Secretary of State's Office, the West Virginia Tax Department, West Virginia Insurance Commission, or any other state agency or political subdivision. Upon request, the Vendor must provide all necessary releases to obtain information to enable the Purchasing Division Director or the Agency to verify that the Vendor is licensed and in good standing with the above entities.

32. ANTITRUST: In submitting a bid to, signing a contract with, or accepting a Award Document from any agency of the State of West Virginia, the Vendor agrees to convey, sell, assign, or transfer to the State of West Virginia all rights, title, and interest in and to all causes of action it may now or hereafter acquire under the antitrust laws of the United States and the State of West Virginia for price fixing and/or unreasonable restraints of trade relating to the particular commodities or services purchased or acquired by the State of West Virginia. Such assignment shall be made and become effective at the time the purchasing agency tenders the initial payment to Vendor.

33. VENDOR CERTIFICATIONS: By signing its bid or entering into this Contract, Vendor certifies (1) that its bid or offer was made without prior understanding, agreement, or connection with any corporation, firm, limited liability company, partnership, person or entity submitting a bid or offer for the same material, supplies, equipment or services; (2) that its bid or offer is in all respects fair and without collusion or fraud; (3) that this Contract is accepted or entered into without any prior understanding, agreement, or connection to any other entity that could be considered a violation of law; and (4) that it has reviewed this Solicitation in its entirety; understands the requirements, terms and conditions, and other information contained herein. Vendor's signature on its bid or offer also affirms that neither it nor its representatives have any interest, nor shall acquire any interest, direct or indirect, which would compromise the performance of its services hereunder. Any such interests shall be promptly presented in detail to the Agency. The individual signing this bid or offer on behalf of Vendor certifies that he or she is authorized by the Vendor to execute this bid or offer or any documents related thereto on Vendor's behalf; that he or she is authorized to bind the Vendor in a contractual relationship; and that, to the best of his or her knowledge, the Vendor has properly registered with any State agency that may require registration.

34. PURCHASING CARD ACCEPTANCE: The State of West Virginia currently utilizes a Purchasing Card program, administered under contract by a banking institution, to process payment for goods and services. The Vendor must accept the State of West Virginia's Purchasing Card for payment of all orders under this Contract unless the box below is checked.

Vendor is not required to accept the State of West Virginia's Purchasing Card as payment for all goods and services.

35. VENDOR RELATIONSHIP: The relationship of the Vendor to the State shall be that of an independent contractor and no principal-agent relationship or employer-employee relationship is contemplated or created by this Contract. The Vendor as an independent contractor is solely liable for the acts and omissions of its employees and agents. Vendor shall be responsible for selecting, supervising, and compensating any and all individuals employed pursuant to the terms of this Solicitation and resulting contract. Neither the Vendor, nor any employees or subcontractors of the Vendor, shall be deemed to be employees of the State for any purpose whatsoever. Vendor shall be exclusively responsible for payment of employees and contractors for all wages and salaries, taxes, withholding payments, penalties, fees, fringe benefits, professional liability insurance premiums, contributions to insurance and pension, or other deferred compensation plans, including but

not limited to, Workers' Compensation and Social Security obligations, licensing fees, etc. and the filing of all necessary documents, forms, and returns pertinent to all of the foregoing. Vendor shall hold harmless the State, and shall provide the State and Agency with a defense against any and all claims including, but not limited to, the foregoing payments, withholdings, contributions, taxes, Social Security taxes, and employer income tax returns.

- 36. INDEMNIFICATION:** The Vendor agrees to indemnify, defend, and hold harmless the State and the Agency, their officers, and employees from and against: (1) Any claims or losses for services rendered by any subcontractor, person, or firm performing or supplying services, materials, or supplies in connection with the performance of the Contract; (2) Any claims or losses resulting to any person or entity injured or damaged by the Vendor, its officers, employees, or subcontractors by the publication, translation, reproduction, delivery, performance, use, or disposition of any data used under the Contract in a manner not authorized by the Contract, or by Federal or State statutes or regulations; and (3) Any failure of the Vendor, its officers, employees, or subcontractors to observe State and Federal laws including, but not limited to, labor and wage and hour laws.
- 37. PURCHASING AFFIDAVIT:** In accordance with West Virginia Code § 5A-3-10a, all Vendors are required to sign, notarize, and submit the Purchasing Affidavit stating that neither the Vendor nor a related party owe a debt to the State in excess of \$1,000. The affidavit must be submitted prior to award, but should be submitted with the Vendor's bid. A copy of the Purchasing Affidavit is included herewith.
- 38. ADDITIONAL AGENCY AND LOCAL GOVERNMENT USE:** This Contract may be utilized by and extends to other agencies, spending units, and political subdivisions of the State of West Virginia; county, municipal, and other local government bodies; and school districts ("Other Government Entities"). This Contract shall be extended to the aforementioned Other Government Entities on the same prices, terms, and conditions as those offered and agreed to in this Contract. If the Vendor does not wish to extend the prices, terms, and conditions of its bid and subsequent contract to the Other Government Entities, the Vendor must clearly indicate such refusal in its bid. A refusal to extend this Contract to the Other Government Entities shall not impact or influence the award of this Contract in any manner.
- 39. CONFLICT OF INTEREST:** Vendor, its officers or members or employees, shall not presently have or acquire an interest, direct or indirect, which would conflict with or compromise the performance of its obligations hereunder. Vendor shall periodically inquire of its officers, members and employees to ensure that a conflict of interest does not arise. Any conflict of interest discovered shall be promptly presented in detail to the Agency.
- 40. REPORTS:** Vendor shall provide the Agency and/or the Purchasing Division with the following reports identified by a checked box below:
- Such reports as the Agency and/or the Purchasing Division may request. Requested reports may include, but are not limited to, quantities purchased, agencies utilizing the contract, total contract expenditures by agency, etc.

- Quarterly reports detailing the total quantity of purchases in units and dollars, along with a listing of purchases by agency. Quarterly reports should be delivered to the Purchasing Division via email at purchasing.requisitions@wv.gov.

41. BACKGROUND CHECK: In accordance with W. Va. Code § 15-2D-3, the Director of the Division of Protective Services shall require any service provider whose employees are regularly employed on the grounds or in the buildings of the Capitol complex or who have access to sensitive or critical information to submit to a fingerprint-based state and federal background inquiry through the state repository. The service provider is responsible for any costs associated with the fingerprint-based state and federal background inquiry.

After the contract for such services has been approved, but before any such employees are permitted to be on the grounds or in the buildings of the Capitol complex or have access to sensitive or critical information, the service provider shall submit a list of all persons who will be physically present and working at the Capitol complex to the Director of the Division of Protective Services for purposes of verifying compliance with this provision.

The State reserves the right to prohibit a service provider's employees from accessing sensitive or critical information or to be present at the Capitol complex based upon results addressed from a criminal background check.

Service providers should contact the West Virginia Division of Protective Services by phone at (304) 558-9911 for more information.

42. PREFERENCE FOR USE OF DOMESTIC STEEL PRODUCTS: Except when authorized by the Director of the Purchasing Division pursuant to W. Va. Code § 5A-3-56, no contractor may use or supply steel products for a State Contract Project other than those steel products made in the United States. A contractor who uses steel products in violation of this section may be subject to civil penalties pursuant to W. Va. Code § 5A-3-56. As used in this section:

- a. "State Contract Project" means any erection or construction of, or any addition to, alteration of or other improvement to any building or structure, including, but not limited to, roads or highways, or the installation of any heating or cooling or ventilating plants or other equipment, or the supply of and materials for such projects, pursuant to a contract with the State of West Virginia for which bids were solicited on or after June 6, 2001.
- b. "Steel Products" means products rolled, formed, shaped, drawn, extruded, forged, cast, fabricated or otherwise similarly processed, or processed by a combination of two or more or such operations, from steel made by the open heath, basic oxygen, electric furnace, Bessemer or other steel making process. The Purchasing Division Director may, in writing, authorize the use of foreign steel products if:
- c. The cost for each contract item used does not exceed one tenth of one percent (.1%) of the total contract cost or two thousand five hundred dollars (\$2,500.00), whichever is greater.

For the purposes of this section, the cost is the value of the steel product as delivered to the project; or

- d. The Director of the Purchasing Division determines that specified steel materials are not produced in the United States in sufficient quantity or otherwise are not reasonably available to meet contract requirements.

43. PREFERENCE FOR USE OF DOMESTIC ALUMINUM, GLASS, AND STEEL: In Accordance with W. Va. Code § 5-19-1 et seq., and W. Va. CSR § 148-10-1 et seq., for every contract or subcontract, subject to the limitations contained herein, for the construction, reconstruction, alteration, repair, improvement or maintenance of public works or for the purchase of any item of machinery or equipment to be used at sites of public works, only domestic aluminum, glass or steel products shall be supplied unless the spending officer determines, in writing, after the receipt of offers or bids, (1) that the cost of domestic aluminum, glass or steel products is unreasonable or inconsistent with the public interest of the State of West Virginia, (2) that domestic aluminum, glass or steel products are not produced in sufficient quantities to meet the contract requirements, or (3) the available domestic aluminum, glass, or steel do not meet the contract specifications. This provision only applies to public works contracts awarded in an amount more than fifty thousand dollars (\$50,000) or public works contracts that require more than ten thousand pounds of steel products.

The cost of domestic aluminum, glass, or steel products may be unreasonable if the cost is more than twenty percent (20%) of the bid or offered price for foreign made aluminum, glass, or steel products. If the domestic aluminum, glass or steel products to be supplied or produced in a "substantial labor surplus area", as defined by the United States Department of Labor, the cost of domestic aluminum, glass, or steel products may be unreasonable if the cost is more than thirty percent (30%) of the bid or offered price for foreign made aluminum, glass, or steel products.

This preference shall be applied to an item of machinery or equipment, as indicated above, when the item is a single unit of equipment or machinery manufactured primarily of aluminum, glass or steel, is part of a public works contract and has the sole purpose or of being a permanent part of a single public works project. This provision does not apply to equipment or machinery purchased by a spending unit for use by that spending unit and not as part of a single public works project.

All bids and offers including domestic aluminum, glass or steel products that exceed bid or offer prices including foreign aluminum, glass or steel products after application of the preferences provided in this provision may be reduced to a price equal to or lower than the lowest bid or offer price for foreign aluminum, glass or steel products plus the applicable preference. If the reduced bid or offer prices are made in writing and supersede the prior bid or offer prices, all bids or offers, including the reduced bid or offer prices, will be reevaluated in accordance with this rule.

CERTIFICATION AND SIGNATURE PAGE

By signing below, or submitting documentation through wvOASIS, I certify that I have reviewed this Solicitation in its entirety; understand the requirements, terms and conditions, and other information contained herein; that I am submitting this bid, offer or proposal for review and consideration; that I am authorized by the vendor to execute and submit this bid, offer, or proposal, or any documents related thereto on vendor's behalf; that I am authorized to bind the vendor in a contractual relationship; and that to the best of my knowledge, the vendor has properly registered with any State agency that may require registration.

Highway Safety
(Company)

Lisa P Booth Lisa P. Booth, President
(Authorized Signature) (Representative Name, Title)

304-453-5636 304-453-5635 3-17-15
(Phone Number) (Fax Number) (Date)

ADDENDUM ACKNOWLEDGEMENT FORM
SOLICITATION NO.: CRFQ DOT1500000059

Instructions: Please acknowledge receipt of all addenda issued with this solicitation by completing this addendum acknowledgment form. Check the box next to each addendum received and sign below. Failure to acknowledge addenda may result in bid disqualification.

Acknowledgment: I hereby acknowledge receipt of the following addenda and have made the necessary revisions to my proposal, plans and/or specification, etc.

Addendum Numbers Received:
(Check the box next to each addendum received)

- | | |
|---|--|
| <input type="checkbox"/> Addendum No. 1 | <input type="checkbox"/> Addendum No. 6 |
| <input type="checkbox"/> Addendum No. 2 | <input type="checkbox"/> Addendum No. 7 |
| <input type="checkbox"/> Addendum No. 3 | <input type="checkbox"/> Addendum No. 8 |
| <input type="checkbox"/> Addendum No. 4 | <input type="checkbox"/> Addendum No. 9 |
| <input type="checkbox"/> Addendum No. 5 | <input type="checkbox"/> Addendum No. 10 |

I understand that failure to confirm the receipt of addenda may be cause for rejection of this bid. I further understand that any verbal representation made or assumed to be made during any oral discussion held between Vendor's representatives and any state personnel is not binding. Only the information issued in writing and added to the specifications by an official addendum is binding.

Highway Safety
Company

Gina P Booth
Authorized Signature

3-17-15
Date

NOTE: This addendum acknowledgment should be submitted with the bid to expedite document processing.

REQUEST FOR QUOTATION
Portable Sign Stands and Reflective Roll-Up Signs

SPECIFICATIONS

1. **PURPOSE AND SCOPE:** The West Virginia Purchasing Division is soliciting bids on behalf of WVDOH to establish an open-end contract for Portable Sign Stands and Reflective Roll-Up Signs.

2. **DEFINITIONS:** The terms listed below shall have the meanings assigned to them below. Additional definitions can be found in section 2 of the General Terms and Conditions.
 - 2.1 **“Contract Item” or “Contract Items”** means the list of items identified in Section 3, Subsection 1 below and on the Pricing Pages.
 - 2.2 **“RFQ”** means the official request for quotation published by the Purchasing Division.
 - 2.3 **“WVDOH”** means West Virginia Department of Highways.
 - 2.4 **“NCHRP-350”** means National Cooperative Highway Research Program Report 350.
 - 2.5 **“AASHTO”** means American Association of State and Highway Transportation Officials.
 - 2.6 **“MPH”** means Miles Per Hour.
 - 2.7 **“MASH”** means the AASHTO Manual for Assessing Safety Hardware, latest edition.
 - 2.8 **“P.V.C.”** means Polyvinyl Chloride.
 - 2.9 **“H&L”** means Hook & Loop.
 - 2.10 **“OZ”** means Ounce.
 - 2.11 **“SQ”** means Square.
 - 2.12 **“YD”** means Yard.
 - 2.13 **“LB”** means Pound.

REQUEST FOR QUOTATION
Portable Sign Stands and Reflective Roll-Up Signs

2.14 “MIN” means Minimum.

2.15 “EA” means Each.

2.16 “ASTM” means American Society for Testing and Materials.

2.17 “Special Provision” means the latest special provision of the WVDOH Standard Specifications for Roads and Bridges pertaining to the retroreflective sheetings. This Special Provision is attached hereto as Exhibit A. Specific compensative requirements of the sheeting manufacturer in the event of material failure, as defined by the material durability and warranty requirements, are included in the Special Provision.

2.18 “WVDOH Sign Fabrication Details” means the manual “WVDOH Sign Fabrication Details, Traffic Engineering Division, September 2005, latest printing. An Internet link to this manual is as follows:

follows <http://www.transportation.wv.gov/highways/engineering/Manuals/Traffic/SIGNFAB/INDEX.pdf>

2.19 “Retroreflective Sign Sheeting APL” means the version of the WVDOH Approved Products list for Retroreflective Sign Sheeting in effect as of the advertising date of this Contract. This APL may be found at: <http://www.transportation.wv.gov/HIGHWAYS/MCST/Pages/Listings.aspx>

The APL is established in a manner consistent with the requirements contained in the latest Special Provision for retroreflective sheeting materials. This Special Provision is described in Section 2.17. Please make reference to Note #1 associated with the APL. The Special Provision is the same as the Special Provision attached as Exhibit A. Per the notes included under Note #1, the second table listed under Note #1 shall be used to verify materials considered to be acceptable to be provided under this Contract. All retroreflective sheeting applied to products supplied under this Contract shall be type ASTM-VI. The APL establishes a list of products that meet the acceptable level of quality and is not intended to reflect a preference or favor any particular brand or vendor. Any manufacturer whose product(s) meet the established level of quality may become an approved supplier and have their product(s) added to the APL in accordance with the approval procedures described in the Special Provision.

2.20 “ASTM specification D4956” means the ASTM specification titled “Standard Specification for Retroreflective Sheeting for Traffic Control”. An Internet link to this specification is as follows: <http://www.astm.org/Standards/D4956.htm>

REQUEST FOR QUOTATION
Portable Sign Stands and Reflective Roll-Up Signs

- 2.21** “MUTCD” means the FHWA publication “Manual on Uniform Traffic Control Devices”, 2009 Edition. An Internet link to this manual is as follows: http://mutcd.fhwa.dot.gov/pdfs/2009/pdf_index.htm
- 2.22** “FHWA” means “Federal Highway Administration”
- 2.23** “Pricing Pages” means the schedule of prices, estimated order quantity, and totals contained in wvOASIS or attached hereto as Exhibit A, and used to evaluate the Solicitation responses.
- 2.24** “Solicitation” means the official notice of an opportunity to supply the State with goods or services that is published by the Purchasing Division.

3. GENERAL REQUIREMENTS:

- 3.1 Contract Items and Mandatory Requirements:** Vendor shall provide Agency with the Contract Items listed below on an open-end and continuing basis. Contract Items must meet or exceed the mandatory requirements as shown below.
- 3.2 Compact Portable Sign Stands – Specifications:** All stands bid shall be approved in accordance with the requirements of the NCHRP or MASH when utilized as described herein.

Compact, portable sign stands shall be capable of holding 36” and 48” diamond roll-up signs a minimum of 12” off the ground. They shall have 4 (four) legs capable of telescoping in or out to utilize both 36” and 48” diamond shaped signs. Each leg, when telescoped out, shall positively lock in the extended position by way of a corrosion resistant steel “push” button type mechanism. Each leg shall have 3 (three) positive locking positions; vertical for storage, and two additional horizontal positions for adjustment on uneven terrain. Legs shall be manufactured for long life utilizing aluminum or hot-dip galvanized steel.

The frame, spring(s), and mast of the stand shall be fabricated of steel, or other approved material, and have the ability to flex if necessary, allowing the complete assembly to have additional wind spilling capability beyond that which is provided by the sign ribs. These components shall be stainless steel, electro-deposit zinc coated steel, hot-dip galvanized steel, powder coated steel, or other approved long life material.

REQUEST FOR QUOTATION
Portable Sign Stands and Reflective Roll-Up Signs

The stand mast shall hold the sign in position by clamping onto the vertical rib of the sign. The clamping device shall accommodate all of the vertical rib sizes detailed as part of this Contract. The clamping device shall be designed such that the sign may be inserted into position using two hands to hold the sign, and be quickly tightened into place thereafter using one hand. Both cam type and screw-in type will be considered, in addition to other similar acceptable designs. Screw-in type mechanisms shall include a tightening knob that may be easily operated in a fast manner, without requiring an excessive number of rotations to tighten.

The stand shall not be excessively heavy, bulky, or cumbersome, as determined by the Traffic Engineering Division staff and additional WVDOH personnel selected by the Traffic Engineering Division to assist in the evaluation of the stands.

The overall "footprint" of the stand with the legs in the retracted and extended positions shall not be excessive, as determined by the office and field staff involved in the evaluation of the stands. The side-to-side dimension of the footprint is critical due to shoulder width considerations, and generally should be limited to 36" in the retracted position, and 60" in the extended position.

The end of each stand leg shall be equipped with a permanently affixed tip manufactured of rubber, or other similar approved material, to deter the stand from "walking".

When using a 36" diamond roll-up sign in retracted leg position, or when using a 48" diamond roll-up sign in the extended leg position, the stand shall remain upright and oriented correctly without any additional ballasting in wind gusts created by 55 MPH and 70 MPH speed limit traffic, respectively. The stand shall be significantly stiff to prevent excessive swaying and twisting of the sign.

All stands shall include a resting or stop point on the mast for the bottom of the vertical mast at which point the bottom of the sign will be at 12" (minimum) mounting height above the surface that the stand is resting on.

Manufacturers are responsible for submitting products to potentially be supplied as part of DOH Contracts for testing and evaluation as these products become available and in advance of the advertisement of these Contracts. All potential stands to be bid as part of this Contract shall have been submitted prior to Contract advertisement for reviews to be performed by Traffic Engineering central office staff and select maintenance personnel. Stands that are reviewed

REQUEST FOR QUOTATION
Portable Sign Stands and Reflective Roll-Up Signs

and determined to meet the construction, performance, and usability requirements of the WVDOH shall be listed herein, and will be the only stands considered for award as part of bids submitted for this Contract.

By bidding this Contract, the Vendor agrees to extend to the WVDOH a four (4) year warranty against defects in workmanship, parts, and materials on all stands supplied as part of this Contract.

3.2.1 Compact Portable Sign Stands – Approved Products

The following manufacturer / model stands have been approved for bidding on this Contract. Bids on this portion of this Contract must specify one of the following models as the stand to be supplied to be considered for award:

- Dicke Tool Uniflex 2000 Sign Stand – **Model UF2000** with aluminum legs, single steel spring, and screw-in type universal sign attachment mechanism.
- MDI Economy Windmaster Sign Stand – **Model 4814SSCKHDK** with aluminum legs, single steel spring, and CamLock cam-type universal sign attachment mechanism.
- Eastern Metal-USA Sign – **Model C-902-DDQA** with aluminum legs.
- Korman Signs – **Model SS548UCA** with aluminum legs, universal latching mechanism with large grip handle, and foot release kick plates.

3.3 Aluminum Substrate Sign and Large Roll-Up Sign Portable Sign Stands – Specifications

All stands bid shall be approved in accordance with the requirements of NCHRP-350 or MASH when utilized as described herein.

Aluminum substrate sign and large roll-up sign portable sign stands shall be capable of holding 0.080 aluminum 48” diamond signs, 48” octagon signs, 48” triangle signs, 36x60 vertical rectangle signs, 60x30 horizontal rectangle signs, and smaller signs, as well as roll-up signs as large as 60x60 square. The stand shall be designed such that the sign mounting height will be 12 in to 24 in off of the ground. Signs designed for higher mounting heights (i.e. 5’ or 7’) shall not be allowed. The stand shall have 4 (four) legs. Each leg shall have 3 (three) positive locking positions; vertical for storage, and two additional horizontal

REQUEST FOR QUOTATION
Portable Sign Stands and Reflective Roll-Up Signs

positions for adjustment on uneven terrain. Legs shall be manufactured for long life utilizing either aluminum or galvanized steel.

The frame, spring(s) and mast of the stand shall be fabricated of steel, or other approved material, and have the ability to flex if necessary, allowing the stand to provide all wind spilling capability for aluminum signs, and additional wind spilling capability beyond that which is provided by the sign ribs for roll-up signs. These components shall be stainless steel, electro-deposit zinc coated steel, hot-dip galvanized steel, powder coated steel, or other approved long life material.

The stand provided shall include all components necessary for installing each of the signs referenced above. The stand shall feature an adjustable mast, adjustable brackets for rigid signs, and an adjustable roll-up sign bracket. The roll-up sign bracket shall accommodate all of the horizontal rib sizes detailed as part of this Contract.

The stand shall not be excessively heavy, bulky, or cumbersome, as determined by the Traffic Engineering Division staff and additional WVDOH personnel selected by the Traffic Engineering Division to assist in the evaluation of the stands.

The overall "footprint" of the stand shall not be excessive. The side-to-side dimension of the footprint is critical due to shoulder width considerations, and generally should be limited to 48". The end-to-end dimension of the footprint should generally be limited to 96".

Manufacturers are responsible for submitting products to potentially be supplied as part of DOH Contracts for testing and evaluation as these products become available and in advance of the advertisement of these Contracts. All potential stands to be bid as part of this Contract shall have been submitted prior to Contract advertisement for reviews to be performed by Traffic Engineering central office staff and select maintenance personnel. Stands that are reviewed and determined to meet the construction, performance, and usability requirements of the WVDOH shall be listed herein, and will be the only stands considered for award as part of bids submitted for this Contract.

By bidding this Contract, the Vendor agrees to extend to the WVDOH a four (4) year warranty against defects in workmanship, parts, and materials on all stands supplied as part of this Contract.

REQUEST FOR QUOTATION
Portable Sign Stands and Reflective Roll-Up Signs

3.3.1 Aluminum Substrate Sign and Large Roll-Up Sign Portable Sign Stands – Approved Products

The following manufacturer / model stands have been approved for bidding on this Contract. Bids on this portion of this Contract must specify one of the following models as the stand to be supplied to be considered for award:

- Eastern Metal-USA Sign – Model X553DD
- Korman Signs – Model SS548E

3.4 Roll Up Signs

3.4.1 Roll-Up Sign Sheeting

All signs and plaques supplied under Section III of this Contract, as defined in Section 4.1, shall be manufactured using Type ASTM-VI sheeting from the WVDOH Approved Products list for Retroreflective Sign Sheeting.

All signs and plaques supplied under Section IV of this Contract, as defined in Section 4.1, shall be manufactured using a sheeting meeting the Type VI material requirements contained within ASTM Specification D4956, latest version. The sheeting used shall be provided by a manufacturer whose fluorescent-orange Type ASTM-VI material is listed on the WVDOH Approved Products list for Retroreflective Sign Sheeting.

3.4.2 Roll-Up Sheeting Splices

In cases where the splicing of roll-up sign material fabric is required as noted herein, the splice shall be accomplished by the following method.

- The seam shall be continuously “bridged” on the back side of the sign by a 4” (minimum) wide strip of 18oz Cooley or equal fabric coated with 200mp adhesive.
- The seam shall be stitched on both the front and back faces of the sign.
- The seam shall be bar tacked on both the front and back faces of the sign on each end of the seam.

REQUEST FOR QUOTATION
Portable Sign Stands and Reflective Roll-Up Signs

3.4.3 Sign Fabrication Specifications

All signs supplied shall have one or more vertical fiberglass ribs, with at least one along the vertical centerline of the sign, unless specified otherwise.

All vertical, horizontal, or diagonal ribs shall be designed to pivot about a metallic pivot point. The metallic pivot point shall be a low profile 3/8" diameter, zinc plated steel tubular rivet. Ribs shall be separated by zinc plated flat washers to allow collapsing and roll up of the sign. The rivet shall be equal to Allied Tubular Rivet Inc.'s Part No. 6503. The flat washers shall also eliminate any slack in the assembly while still allowing rotation of the cross braces.

All signs shall be furnished with fabric corner pockets that are accurately placed so that when the sign is assembled with the cross bracing the fit maintains a taut professional look that does not bow or sag. The pockets shall be made from a 15 oz./sq.yd. min. woven fabric with yarn .018 min. in diameter that consists of approximately 80% P.V.C. and 20% polyester thread, yielding a minimum of 52 total threads per square inch. The material is finished with heat and pressure in such a way to stabilize the fabric against excess stretch and provide adequate seam strength. The ASTM D3787 ball burst strength should be at least 320 lbs.

Pockets must be triangular in shape [or rectangular as required for ribs that require pockets but are not installed in a sign corner forming a 90 degree angle] and consist of 2 independent square pieces that are folded to form an isosceles triangle and sewn together making it 4 ply. The piece that is in contact with the back of the sign shall be either 9x9 or 7x7 (see table below) and the top piece that creates the pocket cavity shall be an 8x8 or 6x6 respectively. The two pieces are sewn together with an exterior grade T-80H min. tex size cotton warp thread around the perimeter except for an area for the pocket cavity that is 2x4-1/4 and 2x2-3/4 in the center of the triangle. All thread shall be orange in color for orange background signs and white in color for all other signs with the exception of fluorescent pink signs. The thread for such signs shall be pink. Two vertical 5/8" long bar tacks are to be sewn at the rib entry and one at the pressure point at the end of the pocket using T-40 min. tex size polyester/cotton corespun thread. The pocket is sewn to the sign following a path around its perimeter with the T-80H thread providing distribution of the rib tension

REQUEST FOR QUOTATION
Portable Sign Stands and Reflective Roll-Up Signs

over a significant area instead of along the corner-to-corner centerline. The edges of the pocket cavity must be parallel to the corner-to-corner axis of the cross braces and the end of the pocket that makes contact with the brace tip must be perpendicular to that axis. Detail drawings are provided below for the 9x9 pocket (Type B) and the 7x7 pocket (Type A).

Rectangular pockets, when required, shall be 2-1/2" wide mesh (see table below), and of sufficient length when folded to form 4 layers of mesh at least 3/4" back from the end of the cross brace and 3 layers on the remaining part of the pocket. The bar tacks shall be 1/2" long minimum up to 5/8" long. Pockets shall be orange in color for orange background signs and white in color for all other signs with the possible exception of fluorescent pink signs. The pockets for such signs may be white or pink.

Pockets shall be installed as close as possible to the edges of the sign. The sewing operation, including but not limited to thread size, equipment, etc. shall be determined and accomplished to not damage the reflective sheeting while providing a product conforming to these specifications.

REQUEST FOR QUOTATION
Portable Sign Stands and Reflective Roll-Up Signs

SIGN SHAPE	POCKET SIZE
48" Diamond	9x9 (Pocket B)
36" Diamond	7x7 (Pocket A)
60x60 Square	9x9 (Pocket B)
48x48 Square	9x9 (Pocket B)
36x48 vert rectangle	9x9 (Pocket B)
36x60 vert rectangle	9x9 (Pocket B)
24x30 vert rectangle	7x7 (Pocket A)
60x30 horiz rectangle	9x9 (Pocket B)
48x36 horiz rectangle	7x7 (Pocket A)
48x30 horiz rectangle	7x7 (Pocket A)
48x24 horiz rectangle	7x7 (Pocket A)
30x24 horiz rectangle	7x7 (Pocket A)
30x18 horiz rectangle	7x7 (Pocket A)
36" octagon	2-1/2W x 2-1/4L rectangular (horizontal rib) 2-1/2W x 3-1/4L rectangular (vertical ribs)
48" octagon	2-1/2W x 2-1/4L rectangular (horizontal rib) 2-1/2W x 3-1/4L rectangular (vertical ribs)
36" triangle	2-1/2W x 2-1/4L rectangular
48" triangle	2-1/2W x 3-1/4L rectangular

With the exception of octagonal (Stop) and triangular (Yield) signs, two pieces of H&L shall be sewn on all non-diamond signs for attachment of the sign to the vertical rib. The H&L shall have sufficient length to encircle the vertical rib and hold the sign taut to the rib. The locations of the two pieces of H&L shall be 2" from the bottom and 2" from the top of the sign to the beginning edge of the H&L and on the sign's vertical centerline. Half of the length shall be hook type and other half shall be loop type with the two types reversed and sewn together and then to the back of the sign.

For the vertical rib of triangular (Yield) signs, only the bottom piece of H&L described above shall be required. In addition, a 3" long piece of H&L shall be attached via adhesive to the side of the rib not touching the back of the sign to allow the rib to be held in position via attachment to the H&L attached to the back sign face.

REQUEST FOR QUOTATION
Portable Sign Stands and Reflective Roll-Up Signs

All vertical ribs of octagonal (stop) signs shall be installed in rectangular pockets. The rectangular pockets for the horizontal rib shall be installed directly under the outside vertical ribs of the sign.

REQUEST FOR QUOTATION
Portable Sign Stands and Reflective Roll-Up Signs

CLOTH CORNER POCKET DESIGNS

TYPE A POCKET DESIGN

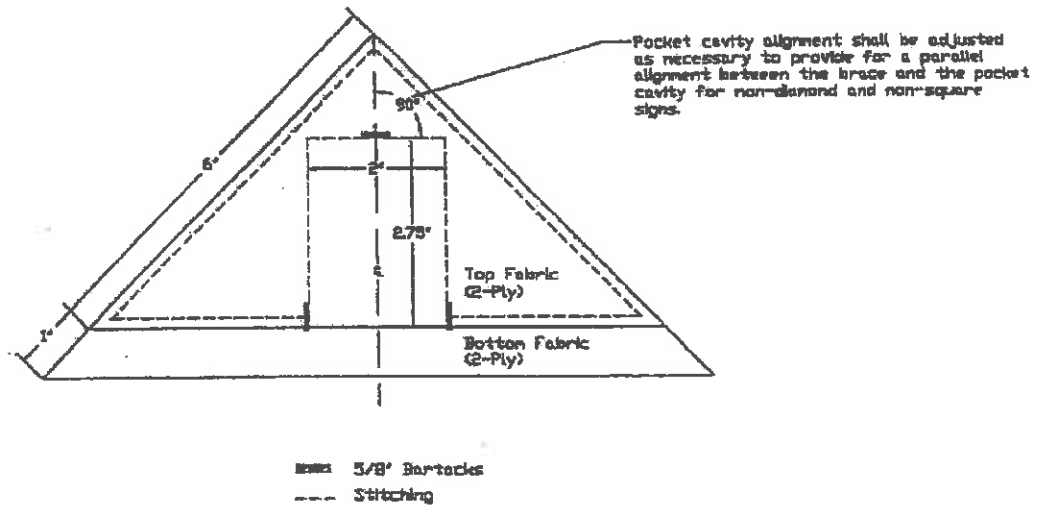

TYPE B POCKET DESIGN

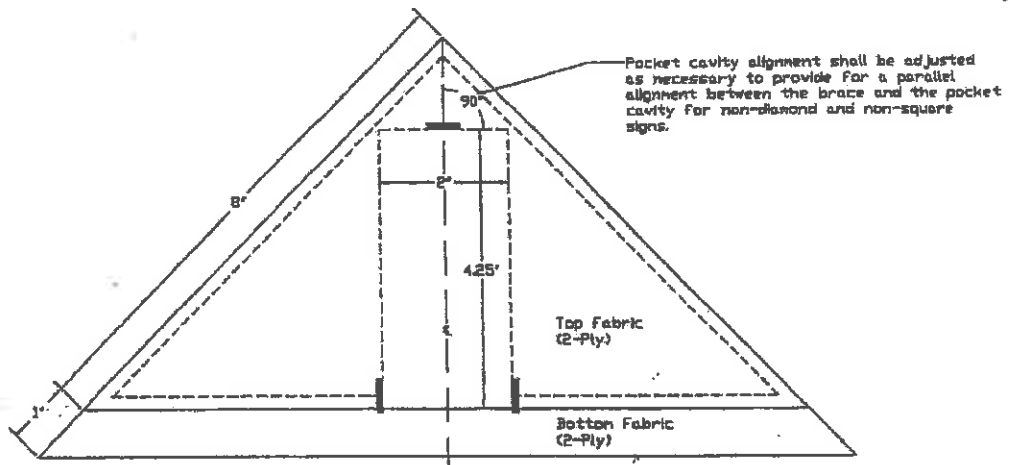

REQUEST FOR QUOTATION
Portable Sign Stands and Reflective Roll-Up Signs

When specified as part of the item description, two 18" x 18" non-reflective fluorescent orange vinyl flags shall be permanently attached to the top of the vertical rib that is along the vertical centerline of the sign. The system for deploying the flags shall be a good quality, long lasting, reliable system. All metal parts of the system shall be stainless steel, electro-deposit zinc coated steel, hot-dip galvanized steel, or powder coated steel. Flag staffs shall be 1/8" thick x 1" wide fiberglass ribs. The staffs shall be sufficiently long enough to hold the flags completely above the sign face. No hand tightening of any components shall be required to hold the flags in the deployed position. When deployed, the two flags shall extend symmetrically (about the vertical centerline) up and out from their mounting point along the vertical rib, with the flags held in position completely above the sign face, and with each staff at an angle of 30 to 60 degrees from the vertical centerline of the sign. Staff mounting and deployment systems shall be subject to review and approval.

For particular signs (see bid item listing) and all overlay plaques requiring H&L strips for temporary overlay attachment, the hook ("coarse") side of the H&L shall be attached to the sign faces. The loop ("fuzzy") side of the H&L shall be attached to the back face of the overlays.

All signs must present a finished, professional look to the motorist with no sagging of the sign material. Signs shall include anti-kite H&L loops attached to the back faces of the signs and to be connected around the ribs of the signs. The sign manufacturer shall determine appropriate locations for anti-kite H&L strips unless otherwise specified herein. An additional length of H&L material shall be fastened near the vertical center of one of the horizontal end points on each sign, and shall be oriented such that when the sign is rolled up on the vertical rib the H&L material will encircle the sign and hold it in the rolled up storing position.

All roll-up signs shall have a permanent sticker affixed to the non-reflective face with the wording "PROPERTY OF WVDOH" in 1/2" minimum legend size.

Identification shall be printed in the margin for convenient indication of the sign message when the sign is rolled up for storage.

The WVDOH reserves the right to and will consider manufacturer proposed adjustments to the rib sizes, rib locations, rib lengths, corner pocket locations, splice locations, and rib rotation points specified herein for each item. Such requests shall be submitted by the manufacturer in writing after award of the

REQUEST FOR QUOTATION
Portable Sign Stands and Reflective Roll-Up Signs

Contract. No acceptance of such requests are implied or guaranteed by the WVDOH.

By bidding this Contract, the Vendor agrees to extend to the WVDOH a one (1) year warranty against defects in workmanship, parts, and materials on all signs supplied as part of this Contract. Sheeting performance failure shall be covered by the approved sheeting manufacturer's warranty provided to the WVDOH, as applicable.

3.4.4 Item 1 – Compact Portable Sign Stand

3.4.5 Item 2 - Large, Aluminum Substrate Sign and Oversized Roll-Up Sign Portable Sign Stand

3.4.6 Item 3 - 36" R1-1F "STOP" SIGN

Signs supplied as part of Bid Item 3 shall be per the WVDOH Sign Fabrication Details, fabrication number R1-1, 36", and shall be octagonal in shape. Rib sizes, rib locations, rib lengths, corner pocket locations, and rotation point location shall be in substantial conformance as shown in the attached drawing (Exhibit C) "36" OCTAGON – CORNER POCKET AND RIB CONFIGURATION".

3.4.7 Item 4 – 48" R1-1F "STOP" SIGN

Signs supplied as part of Bid Item 4 shall be per the WVDOH Sign Fabrication Details, fabrication number R1-1, 48", and shall be octagonal in shape. Rib sizes, rib locations, rib lengths, corner pocket locations, and rotation point location shall be in substantial conformance as shown in the attached drawing (Exhibit D) "48" OCTAGON – CORNER POCKET AND RIB CONFIGURATION".

3.4.8 Item 5 – 36" W3-1MF SYMBOLIC "STOP AHEAD" SIGN

Signs supplied as part of Bid Item 5 shall be per the WVDOH Sign Fabrication Details, fabrication number W3-1M, 36". An orange background shall be used. The symbol may be glued or sewn onto the sign face separately. Rib sizes, rib locations, rib lengths, corner pocket locations, and rotation point location shall be in substantial conformance as shown in the attached drawing (Exhibit E) "36" DIAMOND – CORNER POCKET AND RIB CONFIGURATION".

3.4.9 Item 6 – 48" W3-1MF SYMBOLIC "STOP AHEAD" SIGN

Signs supplied as part of Bid Item 6 shall be per the WVDOH Sign Fabrication Details, fabrication number W3-1M, 48". An orange background shall be used. The symbol may be glued or sewn onto the sign face separately. Rib sizes, rib locations, rib lengths, corner pocket locations, and rotation point location shall be in substantial conformance as shown in the attached drawing (Exhibit F) "48" DIAMOND – CORNER POCKET AND RIB CONFIGURATION".

REQUEST FOR QUOTATION
Portable Sign Stands and Reflective Roll-Up Signs

3.4.10 Item 7 – 36” R1-2F “YIELD” SIGN

Signs supplied as part of Bid Item 7 shall be per the WVDOH Sign Fabrication Details, fabrication number R1-2, 36”, and shall be triangular in shape. Rib sizes, rib locations, rib lengths, corner pocket locations, and rotation point location shall be in substantial conformance as shown in the attached drawing (Exhibit G) “36” TRIANGLE – CORNER POCKET AND RIB CONFIGURATION”.

3.4.11 Item 8 – 48” R1-2F “YIELD” SIGN

Signs supplied as part of Bid Item 8 shall be per the WVDOH Sign Fabrication Details, fabrication number R1-2, 48”, and shall be triangular in shape. Rib sizes, rib locations, rib lengths, corner pocket locations, and rotation point location shall be in substantial conformance as shown in the attached drawing (Exhibit H) “48” TRIANGLE – CORNER POCKET AND RIB CONFIGURATION”.

3.4.12 Item 9 – 36” W3-2MF SYMBOLIC “YIELD AHEAD” SIGN

Signs supplied as part of Bid Item 9 shall be per the WVDOH Sign Fabrication Details, fabrication number W3-2M, 36”. An orange background shall be used. The symbol may be glued or sewn onto the sign face separately. Rib sizes, rib locations, rib lengths, corner pocket locations, and rotation point location shall be in substantial conformance as shown in the attached drawing (Exhibit E) “36” DIAMOND – CORNER POCKET AND RIB CONFIGURATION”.

3.4.13 Item 10 – 48” W3-2MF SYMBOLIC “YIELD AHEAD” SIGN

Signs supplied as part of Bid Item 10 shall be per the WVDOH Sign Fabrication Details, fabrication number W3-2M, 48”. An orange background shall be used. The symbol may be glued or sewn onto the sign face separately. Rib sizes, rib locations, rib lengths, corner pocket locations, and rotation point location shall be in substantial conformance as shown in the attached drawing (Exhibit F) “48” DIAMOND – CORNER POCKET AND RIB CONFIGURATION”.

3.4.14 Item 11 – 36”x60” R2-1MF “WORK ZONE SPEED LIMIT _____” with hook & loop for numeral overlay plaques

Signs supplied as part of Bid Item 11 shall be per the attached drawing “**BID ITEM 11 MODIFIED STANDARD DETAIL**” (Exhibit I). Overall size shall be 36”x60”. All text shall be black. The background above the horizontal border shall be orange. The background below the horizontal border shall be white. The seam between the upper (orange background) and bottom (white background) portions of the sign shall be sewn along the black border in the manner specified above in Section 3.4.2. No numerals shall be screened onto the sign face. 2 ea. 28” long x 1” (min) wide pieces of H&L shall be glued or sewn onto the sign face, as shown on the attached modified standard detail, to facilitate the attachment of the interchangeable numerals to be supplied as part of Bid Item 12. Rib sizes, rib locations, rib lengths, corner pocket locations, and rotation point location shall be in substantial conformance as shown in the attached

REQUEST FOR QUOTATION
Portable Sign Stands and Reflective Roll-Up Signs

drawing (Exhibit J) **“36X60 VERTICAL RECTANGLE – CORNER POCKET AND RIB CONFIGURATION”**.

3.4.15 Item 12 – 14”x17” NUMERAL OVERLAY PLAQUES FOR ITEM #11

Items supplied as part of Bid Item 12 shall be individual numeral plaques intended to be attached to the face of signs supplied under Bid Item 11. The numeral portions of the plaques shall be black, and the background portions shall be white. The overall size of each individual plaque shall be 17” tall x 14” wide. Numerals shall be 15” Series E, and shall be centered vertically and horizontally in each plaque. 2 ea. 14” long x 1” (min) wide pieces of H&L shall be glued or sewn onto the back face of each plaque, with 1 ea. of the pieces along the top and bottom edges of the plaque, and with the outside edge of each piece along the outside edge of the plaque. Orders will specify the quantity of each individual numeral to be supplied.

3.4.16 Item 13 – 48”x24” R4-14(L/R)F “ALL TRAFFIC (WITH INTERCHANGEABLE ARROW HEAD)”

Signs supplied as part of Bid Item 13 shall be per the attached drawing **“BID ITEM 13 MODIFIED STANDARD DETAIL”** (Exhibit K). The text, arrow shaft, and border portions of the sign shall be black, and the background portion shall be white. 4 ea. 8” long x 1” (min) wide pieces of white H&L shall be glued or sewn onto the sign face, as shown on the attached detail, to facilitate the attachment of the included detachable arrow head as described below. Rib sizes, rib locations, rib lengths, corner pocket locations, and rotation point location shall be in substantial conformance as shown in the attached drawing (Exhibit L) **“48X24 HORIZONTAL RECTANGLE – CORNER POCKET AND RIB CONFIGURATION”**.

With each of the signs supplied as part of this bid item, 1 ea. separate arrow head plaque, intended to be attached to the face of the sign, shall be supplied as detailed on the above referenced modified standard detail. 2 ea. 8” long x 1” (min) wide pieces of H&L shall be glued or sewn onto the back face of each plaque, with 1 ea. of the pieces along the top and bottom edges of the plaque, and with the outside edge of each piece along the outside edge of the plaque. The arrow head and shaft portions of the plaque shall be black, and the background portion shall be white.

3.4.17 Item 14 – 24”x30” R4-7BF “KEEP RIGHT” SIGN

Signs supplied as part of Bid Item 14 shall be per the WVDOH Sign Fabrication Details, fabrication number R4-7B, 24”X30”. Rib sizes, rib locations, rib lengths, corner pocket locations, and rotation point location shall be in substantial conformance as shown in the attached drawing (Exhibit M) **“24X30 VERTICAL RECTANGLE – CORNER POCKET AND RIB CONFIGURATION”**

3.4.18 Item 15 – 36”x48” R4-7BF “KEEP RIGHT” SIGN

Signs supplied as part of Bid Item 15 shall be per the WVDOH Sign Fabrication Details, fabrication number R4-7B, 36”X48”. Rib sizes, rib locations, rib lengths, corner pocket locations, and rotation point location shall be in substantial conformance as shown in the

REQUEST FOR QUOTATION
Portable Sign Stands and Reflective Roll-Up Signs

attached drawing (Exhibit N) “**36X48 VERTICAL RECTANGLE – CORNER POCKET AND RIB CONFIGURATION**”.

3.4.19 Item 16 – 30”x18” R9-9F “SIDEWALK CLOSED”

Signs supplied as part of Bid Item 16 shall be per the WVDOH Sign Fabrication Details, fabrication number R9-9. Rib sizes, rib locations, rib lengths, corner pocket locations, and rotation point location shall be in substantial conformance as shown in the attached drawing (Exhibit O) “**30X18 HORIZONTAL RECTANGLE – CORNER POCKET AND RIB CONFIGURATION**”.

3.4.20 Item 17 – 48”x30” R11-2F “ROAD CLOSED” WITH HOOK & LOOP FOR OVERLAY PLAQUES

Signs supplied as part of Bid Item 17 shall be per the attached drawing “**BID ITEM 17 MODIFIED STANDARD DETAIL**” (Exhibit P). The text and border portions of the sign shall be black, and the background portion shall be white. 2 ea. 39” long x 1” wide pieces of white H&L shall be glued or sewn onto the sign face, as shown on the attached modified standard detail, to facilitate the attachment of the interchangeable “**BRIDGE**” and “**RAMP**” plaques to be supplied as part of Bid Item 18. Rib sizes, rib locations, rib lengths, corner pocket locations, and rotation point location shall be in substantial conformance as shown in the attached drawing (Exhibit Q) “**48x30 HORIZONTAL RECTANGLE – CORNER POCKET AND RIB CONFIGURATION**”.

3.4.21 Item 18 – 10”x39” “BRIDGE” AND “RAMP” OVERLAY PLAQUES FOR ITEM #17

Items supplied as part of Bid Item 18 shall be individual message “**BRIDGE**” and “**RAMP**” plaques intended to be attached to the face of signs supplied under Bid Item 17. The text portions of the plaques shall be black, and the background portions shall be white. The overall size of each individual plaque shall be 10” tall x 39” wide. Text shall be 8” Series D, and shall be centered vertically and horizontally in each plaque. 2 ea. 39” long x 1” wide pieces of H&L shall be glued or sewn onto the back face of each plaque, with 1 ea. of the pieces along the top and bottom edges of the plaque, and with the outside edge of each piece along the outside edge of the plaque. Orders will specify the quantity of each individual message (“**BRIDGE**” and “**RAMP**”) to be supplied.

3.4.22 Item 19 – 60”x30” R11-3AF “ROAD CLOSED ____ MI AHEAD LOCAL TRAFFIC ONLY” WITH HOOK & LOOP FOR NUMERAL OVERLAY PLAQUES

Signs supplied as part of Bid Item 19 shall be per the attached drawing “**BID ITEM 19 MODIFIED STANDARD DETAIL**” (Exhibit R). The text and border portions of the sign shall be black, and the background portion shall be white. No numerals shall be screened onto the sign face. 2 ea. 10” long x 1” (min) wide pieces of white H&L shall be glued or sewn onto the sign face, as shown on the attached modified standard detail, to facilitate the attachment of the interchangeable numeral plaques to be supplied as part of Bid Item 20. Rib sizes, rib locations, rib lengths, corner pocket locations, and rotation point location shall be in substantial conformance as shown in the attached drawing

REQUEST FOR QUOTATION
Portable Sign Stands and Reflective Roll-Up Signs

(Exhibit S) “60x30 HORIZONTAL RECTANGLE – CORNER POCKET AND RIB CONFIGURATION”.

3.4.23 Item 20 – 5”x7” NUMERAL OVERLAY PLAQUES FOR ITEM #19

Items supplied as part of Bid Item 20 shall be individual numeral plaques intended to be attached to the face of signs supplied under Bid Item 19. The numeral portions of the plaques shall be black, and the background portions shall be white. The overall size of each individual plaque shall be 7” tall x 5” wide. Numerals shall be 5” Series C, and shall be centered vertically and horizontally in each plaque. 2 ea. 5” long x 1” (min) wide pieces of H&L shall be glued or sewn onto the back face of each plaque, with 1 ea. of the pieces along the top and bottom edges of the plaque, and with the outside edge of each piece along the outside edge of the plaque. Orders will specify the quantity of each individual numeral to be supplied.

3.4.24 Item 21 – 60”x30” R11-4F “ROAD CLOSED TO THRU TRAFFIC”

Signs supplied as part of Bid Item 21 shall be per the WVDOH Sign Fabrication Details, fabrication number R11-4. Rib sizes, rib locations, rib lengths, corner pocket locations, and rotation point location shall be in substantial conformance as shown in the attached drawing (Exhibit S) “60x30 HORIZONTAL RECTANGLE – CORNER POCKET AND RIB CONFIGURATION”.

3.4.25 Item 22 – 48”x36” W22-10F “EXIT _____” WITH HOOK & LOOP FOR OVERLAYS

Signs supplied as part of Bid Item 22 shall be per the attached drawing “**BID ITEM 22 MODIFIED STANDARD DETAIL**” (Exhibit T). The text and border portions of the sign shall be black, and the background portion shall be orange. 2 ea. 40” long x 1” (min) wide pieces of H&L shall be glued or sewn onto the sign face, as shown on the attached modified standard detail, to facilitate the attachment of the interchangeable message plaques to be supplied as part of Bid Item 23. Rib sizes, rib locations, rib lengths, corner pocket locations, and rotation point location shall be in substantial conformance as shown in the attached drawing (Exhibit U) “**48x36 HORIZONTAL RECTANGLE – CORNER POCKET AND RIB CONFIGURATION**”.

3.4.26 Item 23 – 10”x40” “OPEN” AND “CLOSED” OVERLAY PLAQUES FOR ITEM #22

Items supplied as part of Bid Item 23 shall be individual message plaques intended to be attached to the face of signs supplied under Bid Item 22. The text portions of the plaques shall be black, and the background portions shall be orange. The overall size of each individual plaque shall be 10” tall x 40” wide. Text shall be 8” Series D, and shall be centered vertically and horizontally in each plaque. 2 ea. 40” long x 1” (min) wide pieces of H&L shall be glued or sewn onto the back face of each plaque, with 1 ea. of the pieces along the top and bottom edges of the plaque, and with the outside edge of each piece along the outside edge of the plaque. Orders will specify the quantity of each individual message (“OPEN” and “CLOSED”) to be supplied.

REQUEST FOR QUOTATION
Portable Sign Stands and Reflective Roll-Up Signs

3.4.27 Item 24 – 60”x60” W22-11F EXIT GORE SIGN

Signs supplied as part of Bid Item 24 shall be per the WVDOH Sign Fabrication Details, fabrication number W22-11. The text and border portions of the sign shall be black, and the background portion of the sign shall be orange. One vertical seam located 12” from the left (front face) edge of the sign will be allowed. The seam shall be manufactured in the manner specified above in Section 3.4.2. Rib sizes, rib locations, rib lengths, corner pocket locations, and rotation point location shall be in substantial conformance as shown in the attached drawing (Exhibit V) “**60X60 SQUARE – CORNER POCKET AND RIB CONFIGURATION**”.

3.4.28 Item 25 – 30”x24” M4-9F STANDARD DETOUR SIGN WITH HOOK & LOOP AND ARROW OVERLAY PLAQUE

Signs supplied as part of Bid Item 25 shall be per the attached drawing (Exhibit W) “**BID ITEM 25 MODIFIED STANDARD DETAIL**”. The text and border portions of the sign shall be black, and the background portion shall be orange. 4 ea. 5” long x ½” wide pieces of H&L shall be glued or sewn onto the sign face, as shown on the attached modified standard detail, to facilitate the attachment of the arrow overlay plaque as described below. Rib sizes, rib locations, rib lengths, corner pocket locations, and rotation point location shall be in substantial conformance as shown in the attached drawing (Exhibit Y) “**30X24 HORIZONTAL RECTANGLE – CORNER POCKET AND RIB CONFIGURATION**”.

With each of the signs supplied as part of this bid item, 1 ea. separate arrow head plaque, intended to be attached to the face of the sign as detailed on the above referenced modified standard detail (Exhibit X), shall be supplied. 8 ea. 5” long x ½” wide pieces of H&L shall be glued or sewn onto the back face of each plaque as shown on the modified standard detail. The arrow head and shaft portions of the plaque shall be black, and the background portion shall be orange.

3.4.29 Item 26 – 48”x48” EMERGENCY RESPONSE TRAILER DETOUR SIGN WITH HOOK & LOOP FOR OVERLAY PLAQUES AND ARROW OVERLAY PLAQUE

Signs supplied as part of Bid Item 26 shall be per the attached drawing “**BID ITEM 26 MODIFIED STANDARD DETAIL**” (Exhibit Z). The text and border portions of the sign shall be black, and the background portion shall be orange. “DETOUR” text size shall be 7” Series D. Border shall be 1.25”. Margin shall be 0.75”. Corner Radius shall be 3”. 2 ea. 41-1/2” long x 1” (min) wide pieces of orange H&L shall be glued or sewn onto the sign face, as shown on the attached modified standard detail, to facilitate the attachment of the interchangeable overlay plaques to be supplied as part of Bid Items 27 and 28. 4 ea. 6” long x ½” wide pieces of H&L shall be glued or sewn onto the sign face, as shown on the attached modified standard detail, to facilitate the attachment of the arrow overlay plaque as described below. Rib sizes, rib locations, rib lengths, corner pocket locations, and rotation point location shall be in substantial conformance as shown in the attached drawing (Exhibit BB) “**48x48 SQUARE – CORNER POCKET AND RIB CONFIGURATION**”.

REQUEST FOR QUOTATION
Portable Sign Stands and Reflective Roll-Up Signs

With each of the signs supplied as part of this bid item, 1 ea. separate arrow head plaque, as detailed on the above referenced modified standard detail (Exhibit AA), intended to be attached to the face of the sign shall be supplied. 8 ea. 6" long x ½" wide pieces of H&L shall be glued or sewn onto the back face of each plaque as shown on the modified standard detail. The arrow head and shaft portions of the plaque shall be black, and the background portion shall be orange.

**3.4.30 Item 27 – 9"x28" EMERGENCY RESPONSE TRAILER
ROUTE OVERLAY PLAQUE FOR ITEM 26**

Items supplied as part of Bid Item 27 shall be individual route plaques intended to be attached to the face of signs supplied under Bid Item 26. The text portions of the plaques shall be black, and the background portions shall be orange. The overall size of each individual plaque shall be 9" tall x 28" wide. Text shall be 8" Series D, or, if necessary, 8" Series C as required for 3 digit routes. Text shall be centered vertically and horizontally in each plaque. Format of text shall be "Route Classification"- "Hyphen"- "Route Number" (i.e. "US-119", "WV-2", "I-79", etc.). 2 ea. 28" long x 1" (min) wide pieces of H&L shall be glued or sewn onto the back face of each plaque, with 1 ea. of the pieces along the top and bottom edges of the plaque, and with the outside edge of each piece along the outside edge of the plaque. Orders will specify the quantity of each individual route plaque to be supplied.

**3.4.31 Item 28 – 9"x7" EMERGENCY RESPONSE TRAILER
CARDINAL DIRECTION OVERLAY PLAQUE FOR ITEM
26**

Items supplied as part of Bid Item 28 shall be individual cardinal direction plaques intended to be attached to the face of signs supplied under Bid Item 26. The text portions of the plaques shall be black, and the background portions shall be orange. The overall size of each individual plaque shall be 9" tall x 7" wide. Text shall be 8" Series D. Text shall be centered vertically and horizontally in each plaque. 2 ea. 7" long x 1" (min) wide pieces of H&L shall be glued or sewn onto the back face of each plaque, with 1 ea. of the pieces along the top and bottom edges of the plaque, and with the outside edge of each piece along the outside edge of the plaque. Orders will specify the quantity of each individual plaque ("N", "S", "E", and "W") to be supplied.

**3.4.32 Item 29 – 48"x48" DIAMOND, FLUORESCENT ORANGE,
STANDARD MESSAGE ROLL-UP SIGN**

Items supplied as part of Bid Item 29 shall be standard message (as shown in the WVDOH Sign Fabrication Details) orange and black 48"x48" diamond shaped construction zone warning signs. The text portions of the signs shall be black, and the background portions shall be orange. Rib sizes, rib locations, rib lengths, corner pocket locations, and rotation point location shall be in substantial conformance as shown in the attached drawing (Exhibit F) "48" DIAMOND – CORNER POCKET AND RIB CONFIGURATION". Orders will specify the quantity of each fabrication number to be supplied.

REQUEST FOR QUOTATION
Portable Sign Stands and Reflective Roll-Up Signs

3.4.33 Item 30 – 48”x48” DIAMOND, FLUORESCENT ORANGE, STANDARD MESSAGE ROLL-UP SIGN, WITH PERMANENT ADDITION OF TWO (2) 18”X18” VINYL FOLDING FLAGS

Items supplied as part of Bid Item 30 shall be standard message (as shown in the WVDOH Sign Fabrication Details) orange and black 48”x48” diamond shaped construction zone warning signs, with the addition of 2 ea. 18” x 18” non-reflective fluorescent orange vinyl flags, as specified above. The text portions of the signs shall be black, and the background portions shall be orange. Rib sizes, rib locations, rib lengths, corner pocket locations, and rotation point location shall be in substantial conformance as shown in the attached drawing (Exhibit F) “48” DIAMOND – CORNER POCKET AND RIB CONFIGURATION”. Orders will specify the quantity of each fabrication number to be supplied.

3.4.34 Item 31 – 36”x36” DIAMOND, FLUORESCENT ORANGE, STANDARD MESSAGE ROLL-UP SIGN

Items supplied as part of Bid Item 31 shall be standard message (as shown in the WVDOH Sign Fabrication Details) orange and black 36”x36” diamond shaped construction zone warning signs. The text portions of the signs shall be black, and the background portions shall be orange. Rib sizes, rib locations, rib lengths, corner pocket locations, and rotation point location shall be in substantial conformance as shown in the attached drawing (Exhibit E) “36” DIAMOND – CORNER POCKET AND RIB CONFIGURATION”. Orders will specify the quantity of each fabrication number to be supplied.

3.4.35 Item 32 – 36”x36” DIAMOND, FLUORESCENT ORANGE, STANDARD MESSAGE ROLL-UP SIGN, WITH PERMANENT ADDITION OF TWO (2) 18”X18” VINYL FOLDING FLAGS

Items supplied as part of Bid Item 32 shall be standard message (as shown in the WVDOH Sign Fabrication Details) orange and black 36”x36” diamond shaped construction zone warning signs, with the addition of 2 ea. 18” x 18” non-reflective fluorescent orange vinyl flags, as specified above. The text portions of the signs shall be black, and the background portions shall be orange. Rib sizes, rib locations, rib lengths, corner pocket locations, and rotation point location shall be in substantial conformance as shown in the attached drawing (Exhibit E) “36” DIAMOND – CORNER POCKET AND RIB CONFIGURATION”. Orders will specify the quantity of each fabrication number to be supplied.

3.4.36 Item 33 – 48”x48” DIAMOND, FLUORESCENT ORANGE, STANDARD MESSAGE ROLL-UP SIGN WITH HOOK & LOOP STRIPS FOR OVERLAY ATTACHMENTS

Items supplied as part of Bid Item 33 shall be standard message (as shown in the WVDOH Sign Fabrication Details) orange and black 48”x48” diamond shaped construction zone warning signs with the addition of 2 ea. 28” long x 1/2” wide and/or 2 ea. 23” long x 1/2” wide orange H&L strips to be glued or sewn onto the sign face. The H&L strips shall be installed horizontally and parallel to one another, with the measured

REQUEST FOR QUOTATION
Portable Sign Stands and Reflective Roll-Up Signs

distance between the outside edges of the strips to be 8". The mid-point along (14" and/or 11-1/2") and between (4") the strips shall be centered vertically and horizontally about the portion of text in the sign specified. The text portions of the signs shall be black, and the background portions shall be orange. Rib sizes, rib locations, rib lengths, corner pocket locations, and rotation point location shall be in substantial conformance as shown in the attached drawing (Exhibit F) "48" DIAMOND – CORNER POCKET AND RIB CONFIGURATION".

For further guidance, included as part of this Contract is a listing of individual signs with which supplemental overlay plaques are frequently used (Exhibit CC). For each sign with multiple possible messages through the use of overlay plaques, this listing specifies a "base" sign message. Each sign ordered with H&L in order to incorporate overlay plaques shall be manufactured with the "base" sign message as the permanent message on the sign. All 48" signs ordered which may potentially be altered with overlay plaques shall be ordered with H&L strips under this Item number or Item number 34. Orders will specify the quantity of each fabrication number to be supplied.

3.4.37 Item 34 – 48"x48" DIAMOND, FLUORESCENT ORANGE, STANDARD MESSAGE ROLL-UP SIGN WITH PERMANENT ADDITION OF TWO (2) 18"x18" VINYL FOLDING FLAGS, AND HOOK & LOOP STRIPS FOR OVERLAY ATTACHMENTS

Items supplied as part of Bid Item 34 shall be standard message (as shown in the WVDOT Sign Fabrication Details) orange and black 48"x48" diamond shaped construction zone warning signs, with the addition of 2 ea. 28" long x 1/2" wide and/or 2 ea. 23" long x 1/2" wide orange H&L strips to be glued or sewn onto the sign face, and 2 ea. 18" x 18" non-reflective fluorescent orange vinyl flags, as specified above. The H&L strips shall be installed horizontally and parallel to one another, with the measured distance between the outside edges of the strips to be 8". The mid-point along (14" and/or 11-1/2") and between (4") the strips shall be centered vertically and horizontally about the portion of text in the sign specified. The text portions of the signs shall be black, and the background portions shall be orange. Rib sizes, rib locations, rib lengths, corner pocket locations, and rotation point location shall be in substantial conformance as shown in the attached drawing (Exhibit F) "48" DIAMOND – CORNER POCKET AND RIB CONFIGURATION".

For further guidance, included as part of this Contract is a listing of individual signs with which supplemental overlay plaques are frequently used (Exhibit CC). For each sign with multiple possible messages through the use of overlay plaques, this listing specifies a "base" sign message. Each sign ordered with H&L in order to incorporate overlay plaques shall be manufactured with the "base" sign message as the permanent message on the sign. All 48" signs ordered which may potentially be altered with overlay plaques shall be ordered with H&L strips under this Item number or Item number 33. Orders will specify the quantity of each fabrication number to be supplied.

3.4.38 Item 35 – 36"x36" DIAMOND, FLUORESCENT ORANGE, STANDARD MESSAGE ROLL-UP SIGN WITH HOOK & LOOP STRIPS FOR OVERLAY ATTACHMENTS

REQUEST FOR QUOTATION
Portable Sign Stands and Reflective Roll-Up Signs

Items supplied as part of Bid Item 35 shall be standard message (as shown in the WVDOH Sign Fabrication Details) orange and black 36"x36" diamond shaped construction zone warning signs with the addition of 2 to 4 ea. 21" long x 1/2" wide orange H&L strips to be glued or sewn onto the sign face. The H&L strips shall be installed horizontally and parallel to one another, with the measured distance between the outside edges of the strips to be 6". The mid-point along (10-1/2") and between (3") the strips shall be centered vertically and horizontally about the portion of text in the sign specified. The text portions of the signs shall be black, and the background portions shall be orange. Rib sizes, rib locations, rib lengths, corner pocket locations, and rotation point location shall be in substantial conformance as shown in the attached drawing (Exhibit E) **"36" DIAMOND – CORNER POCKET AND RIB CONFIGURATION"**.

For further guidance, included as part of this Contract is a listing of individual signs with which supplemental overlay plaques are frequently used (Exhibit CC). For each sign with multiple possible messages through the use of overlay plaques, this listing specifies a "base" sign message. Each sign ordered with H&L in order to incorporate overlay plaques shall be manufactured with the "base" sign message as the permanent message on the sign. All 36" signs ordered which may potentially be altered with overlay plaques shall be ordered with H&L strips under this Item number or Item number 36. Orders will specify the quantity of each fabrication number to be supplied.

3.4.39 Item 36 – 36"x36" DIAMOND, FLUORESCENT ORANGE, STANDARD MESSAGE ROLL-UP SIGN WITH PERMANENT ADDITION OF TWO (2) 18"x18" VINYL FOLDING FLAGS, AND HOOK & LOOP STRIPS FOR OVERLAY ATTACHMENTS

Items supplied as part of Bid Item 36 shall be standard message (as shown in the WVDOH Sign Fabrication Details) orange and black 36"x36" diamond shaped construction zone warning signs with the addition of 2 to 4 ea. 21" long x 1/2" wide orange H&L strips to be glued or sewn onto the sign face, and 2 ea. 18" x 18" non-reflective fluorescent orange vinyl flags, as specified above. The H&L strips shall be installed horizontally and parallel to one another, with the measured distance between the outside edges of the strips to be 6". The mid-point along (10-1/2") and between (3") the strips shall be centered vertically and horizontally about the portion of text in the sign specified. The text portions of the signs shall be black, and the background portions shall be orange. Rib sizes, rib locations, rib lengths, corner pocket locations, and rotation point location shall be in substantial conformance as shown in the attached drawing (Exhibit E) **"36" DIAMOND – CORNER POCKET AND RIB CONFIGURATION"**.

For further guidance, included as part of this Contract is a listing of individual signs with which supplemental overlay plaques are frequently used (Exhibit CC). For each sign with multiple possible messages through the use of overlay plaques, this listing specifies a "base" sign message. Each sign ordered with H&L in order to incorporate overlay plaques shall be manufactured with the "base" sign message as the permanent message on the sign. All 36" signs ordered which may potentially be altered with overlay plaques shall be ordered with H&L strips under this Item number or Item number 35. Orders will specify the quantity of each fabrication number to be supplied.

REQUEST FOR QUOTATION
Portable Sign Stands and Reflective Roll-Up Signs

3.4.40 Item 37 – 8"x21" ("LEFT" AND "CENTER" TEXT ONLY) OR 8"x28" FLUORESCENT ORANGE OVERLAYS WITH HOOK & LOOP STRIPS FOR USE WITH ITEM 33 AND 34. EXAMPLES; LEFT, 500 FT., 1000 FT., 1500 FT., ½ MILE, AND 1 MILE

Items supplied as part of Bid Item 37 shall be individual message plaques intended to be attached to the face of signs supplied under Bid Items 33 and 34. The text portions of the plaques shall be black, and the background portions shall be orange. The overall size of each individual plaque, with the exception of "LEFT" and "CENTER" plaques, shall be 8" tall x 28" wide. "LEFT" and "CENTER" plaques shall be 8" tall x 23" wide. Text shall be 7" Series C. Text shall be centered vertically and horizontally in each plaque. 2 ea. 28" (23" in the case of "LEFT" or "CENTER" plaque) long x ½" wide pieces of H&L shall be glued or sewn onto the back face of each plaque, with 1 ea. of the pieces along the top and bottom edges of the plaque, and with the outside edge of each piece along the outside edge of the plaque. Orders will specify the quantity of each individual plaque to be supplied.

Note, "AHEAD" plaques shall not be manufactured or supplied under this Item number.

3.4.41 Item 38 – 6"x21" FLUORESCENT ORANGE OVERLAYS WITH HOOK & LOOP STRIPS FOR USE WITH ITEM NUMBERS 35 AND 36. EXAMPLES: LEFT, 500 FT., 1000 FT., 1500 FT., ½ MILE, 1 MILE, AND AHEAD

Items supplied as part of Bid Item 38 shall be individual message plaques intended to be attached to the face of signs supplied under Bid Items 35 and 36. The text portions of the plaques shall be black, and the background portions shall be orange. The overall size of each individual plaque shall be 6" tall x 21" wide. Text shall be 5" Series C. Text shall be centered vertically and horizontally in each plaque. 2 ea. 21" long x ½" wide pieces of H&L shall be glued or sewn onto the back face of each plaque, with 1 ea. of the pieces along the top and bottom edges of the plaque, and with the outside edge of each piece along the outside edge of the plaque. Orders will specify the quantity of each individual plaque to be supplied.

3.4.42 Item 39 – 18"x36" G20-2 "END ROAD WORK" SIGN

Signs supplied as part of Bid Item 39 shall be per the WVDOH Sign Fabrication Details, fabrication number G20-2, 18"x36". Rib sizes, rib locations, rib lengths, corner pocket locations, and rotation point location shall be in substantial conformance as shown in the attached drawing (Exhibit DD) "18x36 HORIZONTAL RECTANGLE – CORNER POCKET AND RIB CONFIGURATION".

3.4.43 Item 40 – 36" W3-1MF SYMBOLIC "STOP AHEAD" SIGN, FLUORESCENT PINK

Signs supplied as part of Bid Item 40 shall be per the WVDOH Sign Fabrication Details, fabrication number W3-1M, 36", with the exception of the background color. An fl-pink background shall be used. The symbol may be glued or sewn onto the sign face separately. Rib sizes, rib locations, rib lengths, corner pocket locations, and rotation point

REQUEST FOR QUOTATION
Portable Sign Stands and Reflective Roll-Up Signs

location shall be in substantial conformance as shown in the attached drawing (Exhibit E) “36” DIAMOND – CORNER POCKET AND RIB CONFIGURATION”.

3.4.44 Item 41 – 48” W3-1MF SYMBOLIC “STOP AHEAD” SIGN, FLUORESCENT PINK

Signs supplied as part of Bid Item 41 shall be per the WVDOH Sign Fabrication Details, fabrication number W3-1M, 48”, with the exception of the background color. An fl-pink background shall be used. The symbol may be glued or sewn onto the sign face separately. Rib sizes, rib locations, rib lengths, corner pocket locations, and rotation point location shall be in substantial conformance as shown in the attached drawing (Exhibit F) “48” DIAMOND – CORNER POCKET AND RIB CONFIGURATION”.

3.4.45 Item 42 – 36” W3-2MF SYMBOLIC “YIELD AHEAD” SIGN, FLUORESCENT PINK

Signs supplied as part of Bid Item 42 shall be per the WVDOH Sign Fabrication Details, fabrication number W3-2M, 36”, with the exception of the background color. An fl-pink background shall be used. The symbol may be glued or sewn onto the sign face separately. Rib sizes, rib locations, rib lengths, corner pocket locations, and rotation point location shall be in substantial conformance as shown in the attached drawing (Exhibit E) “36” DIAMOND – CORNER POCKET AND RIB CONFIGURATION”.

3.4.46 Item 43 – 48” W3-2MF SYMBOLIC “YIELD AHEAD” SIGN, FLUORESCENT PINK

Signs supplied as part of Bid Item 10 shall be per the WVDOH Sign Fabrication Details, fabrication number W3-2M, 48”, with the exception of the background color. An fl-pink background shall be used. The symbol may be glued or sewn onto the sign face separately. Rib sizes, rib locations, rib lengths, corner pocket locations, and rotation point location shall be in substantial conformance as shown in the attached drawing (Exhibit F) “48” DIAMOND – CORNER POCKET AND RIB CONFIGURATION”.

3.4.47 Item 44 – 48”x36” W22-10F “EXIT _____” WITH HOOK & LOOP FOR OVERLAYS, FLUORESCENT PINK

Signs supplied as part of Bid Item 44 shall be per the attached drawing “BID ITEM 22 MODIFIED STANDARD DETAIL” (Exhibit T). The text and border portions of the sign shall be black, and the background portion shall be fl-pink. 2 ea. 40” long x 1” (min) wide pieces of H&L shall be glued or sewn onto the sign face, as shown on the attached modified standard detail, to facilitate the attachment of the interchangeable message plaques to be supplied as part of Bid Item 45. Rib sizes, rib locations, rib lengths, corner pocket locations, and rotation point location shall be in substantial conformance as shown in the attached drawing (Exhibit U) “48x36 HORIZONTAL RECTANGLE – CORNER POCKET AND RIB CONFIGURATION”.

3.4.48 Item 45 – 10”x40” “OPEN” AND “CLOSED” OVERLAY PLAQUES FOR ITEM #44, FLUORESCENT PINK

Items supplied as part of Bid Item 45 shall be individual message plaques intended to be attached to the face of signs supplied under Bid Item 44. The text portions of the plaques

REQUEST FOR QUOTATION
Portable Sign Stands and Reflective Roll-Up Signs

shall be black, and the background portions shall be fl-pink. The overall size of each individual plaque shall be 10" tall x 40" wide. Text shall be 8" Series D, and shall be centered vertically and horizontally in each plaque. 2 ea. 40" long x 1" (min) wide pieces of H&L shall be glued or sewn onto the back face of each plaque, with 1 ea. of the pieces along the top and bottom edges of the plaque, and with the outside edge of each piece along the outside edge of the plaque. Orders will specify the quantity of each individual message ("OPEN" and "CLOSED") to be supplied.

3.4.49 Item 46 – 30"x24" M4-9F STANDARD DETOUR SIGN WITH HOOK & LOOP AND ARROW OVERLAY PLAQUE, FLUORESCENT PINK

Signs supplied as part of Bid Item 46 shall be per the attached drawing (Exhibit W) "BID ITEM 25 MODIFIED STANDARD DETAIL". The text and border portions of the sign shall be black, and the background portion shall be fl-pink. 4 ea. 5" long x ½" wide pieces of H&L shall be glued or sewn onto the sign face, as shown on the attached modified standard detail, to facilitate the attachment of the arrow overlay plaque as described below. Rib sizes, rib locations, rib lengths, corner pocket locations, and rotation point location shall be in substantial conformance as shown in the attached drawing (Exhibit Y) "30X24 HORIZONTAL RECTANGLE – CORNER POCKET AND RIB CONFIGURATION".

With each of the signs supplied as part of this bid item, 1 ea. separate arrow head plaque, intended to be attached to the face of the sign as detailed on the above referenced modified standard detail (Exhibit X), shall be supplied. 8 ea. 5" long x ½" wide pieces of H&L shall be glued or sewn onto the back face of each plaque as shown on the modified standard detail. The arrow head and shaft portions of the plaque shall be black, and the background portion shall be fl-pink.

3.4.50 Item 47 – 48"x48" EMERGENCY RESPONSE TRAILER DETOUR SIGN WITH HOOK & LOOP FOR OVERLAY PLAQUES AND ARROW OVERLAY PLAQUE, FLUORESCENT PINK

Signs supplied as part of Bid Item 47 shall be per the attached drawing "BID ITEM 26 MODIFIED STANDARD DETAIL" (Exhibit Z). The text and border portions of the sign shall be black, and the background portion shall be fl-pink. "DETOUR" text size shall be 7" Series D. Border shall be 1.25". Margin shall be 0.75". Corner Radius shall be 3". 2 ea. 41-1/2" long x 1" (min) wide pieces of pink H&L shall be glued or sewn onto the sign face, as shown on the attached modified standard detail, to facilitate the attachment of the interchangeable overlay plaques to be supplied as part of Bid Items 48 and 49. 4 ea. 6" long x ½" wide pieces of H&L shall be glued or sewn onto the sign face, as shown on the attached modified standard detail, to facilitate the attachment of the arrow overlay plaque as described below. Rib sizes, rib locations, rib lengths, corner pocket locations, and rotation point location shall be in substantial conformance as shown in the attached drawing (Exhibit BB) "48x48 SQUARE – CORNER POCKET AND RIB CONFIGURATION".

With each of the signs supplied as part of this bid item, 1 ea. separate arrow head plaque, as detailed on the above referenced modified standard detail (Exhibit AA), intended to be

REQUEST FOR QUOTATION
Portable Sign Stands and Reflective Roll-Up Signs

attached to the face of the sign shall be supplied. 8 ea. 6" long x ½" wide pieces of H&L shall be glued or sewn onto the back face of each plaque as shown on the modified standard detail. The arrow head and shaft portions of the plaque shall be black, and the background portion shall be fl-pink.

3.4.51 Item 48 – 9"x28" EMERGENCY RESPONSE TRAILER ROUTE OVERLAY PLAQUE FOR ITEM 47, FLUORESCENT PINK

Items supplied as part of Bid Item 48 shall be individual route plaques intended to be attached to the face of signs supplied under Bid Item 47. The text portions of the plaques shall be black, and the background portions shall be fl-pink. The overall size of each individual plaque shall be 9" tall x 28" wide. Text shall be 8" Series D, or, if necessary, 8" Series C as required for 3 digit routes. Text shall be centered vertically and horizontally in each plaque. Format of text shall be "Route Classification"- "Hyphen"- "Route Number" (i.e. "US-119", "WV-2", "I-79", etc.). 2 ea. 28" long x 1" (min) wide pieces of H&L shall be glued or sewn onto the back face of each plaque, with 1 ea. of the pieces along the top and bottom edges of the plaque, and with the outside edge of each piece along the outside edge of the plaque. Orders will specify the quantity of each individual route plaque to be supplied.

3.4.52 Item 49 – 9"x7" EMERGENCY RESPONSE TRAILER CARDINAL DIRECTION OVERLAY PLAQUE FOR ITEM 47, FLUORESCENT PINK

Items supplied as part of Bid Item 49 shall be individual cardinal direction plaques intended to be attached to the face of signs supplied under Bid Item 47. The text portions of the plaques shall be black, and the background portions shall be fl-pink. The overall size of each individual plaque shall be 9" tall x 7" wide. Text shall be 8" Series D. Text shall be centered vertically and horizontally in each plaque. 2 ea. 7" long x 1" (min) wide pieces of H&L shall be glued or sewn onto the back face of each plaque, with 1 ea. of the pieces along the top and bottom edges of the plaque, and with the outside edge of each piece along the outside edge of the plaque. Orders will specify the quantity of each individual plaque ("N", "S", "E", and "W") to be supplied.

3.4.53 Item 50 – 48"x48" DIAMOND, FLUORESCENT PINK, STANDARD MESSAGE ROLL-UP SIGN

Items supplied as part of Bid Item 50 shall be standard message (as shown in the WVDOH Sign Fabrication Details) fl-pink and black 48"x48" diamond shaped warning signs. The text portions of the signs shall be black, and the background portions shall be fl-pink. Rib sizes, rib locations, rib lengths, corner pocket locations, and rotation point location shall be in substantial conformance as shown in the attached drawing (Exhibit F) "48" DIAMOND – CORNER POCKET AND RIB CONFIGURATION". Orders will specify the quantity of each fabrication number to be supplied.

The Agency reserves the right to order additional signs with messages not currently specified in the MUTCD (non-standard messages). Such signs shall be indicated on the order. The size, font type, spacing, and layout of the text on such signs shall be in conformance with the recommendations of the MUTCD. When such non-standard

REQUEST FOR QUOTATION
Portable Sign Stands and Reflective Roll-Up Signs

message signs are ordered, the Vendor shall provide electronic shop drawings of these signs by email to the Agency for approval prior to proceeding with fabrication.

**3.4.54 Item 51 – 36”x36” DIAMOND, FLUORESCENT PINK ,
STANDARD MESSAGE ROLL-UP SIGN**

Items supplied as part of Bid Item 51 shall be standard message (as shown in the WVDOH Sign Fabrication Details) fl-pink and black 36”x36” diamond shaped warning signs. The text portions of the signs shall be black, and the background portions shall be fl-pink. Rib sizes, rib locations, rib lengths, corner pocket locations, and rotation point location shall be in substantial conformance as shown in the attached drawing (Exhibit E) “36” DIAMOND – CORNER POCKET AND RIB CONFIGURATION”. Orders will specify the quantity of each fabrication number to be supplied.

The Agency reserves the right to order additional signs with messages not currently specified in the MUTCD (non-standard messages). Such signs shall be indicated on the order. The size, font type, spacing, and layout of the text on such signs shall be in conformance with the recommendations of the MUTCD. When such non-standard message signs are ordered, the Vendor shall provide electronic shop drawings of these signs by email to the Agency for approval prior to proceeding with fabrication.

**3.4.55 Item 52 – 48”x48” DIAMOND, FLUORESCENT PINK,
STANDARD MESSAGE ROLL-UP SIGN WITH HOOK & LOOP
STRIPS FOR OVERLAY ATTACHMENTS**

Items supplied as part of Bid Item 52 shall be standard message (as shown in the WVDOH Sign Fabrication Details) fl-pink and black 48”x48” diamond shaped warning signs with the addition of 2 ea. 28” long x 1/2” wide and/or 2 ea. 23” long x 1/2” wide pink H&L strips to be glued or sewn onto the sign face. The H&L strips shall be installed horizontally and parallel to one another, with the measured distance between the outside edges of the strips to be 8”. The mid-point along (14” and/or 11-1/2”) and between (4”) the strips shall be centered vertically and horizontally about the portion of text in the sign specified. The text portions of the signs shall be black, and the background portions shall be fl-pink. Rib sizes, rib locations, rib lengths, corner pocket locations, and rotation point location shall be in substantial conformance as shown in the attached drawing (Exhibit F) “48” DIAMOND – CORNER POCKET AND RIB CONFIGURATION”.

For further guidance, included as part of this Contract is a listing of individual signs with which supplemental overlay plaques are frequently used (Exhibit CC). For each sign with multiple possible messages through the use of overlay plaques, this listing specifies a “base” sign message. Each sign ordered with H&L in order to incorporate overlay plaques shall be manufactured with the “base” sign message as the permanent message on the sign. All 48” signs ordered which may potentially be altered with overlay plaques shall be ordered with H&L strips under this Item number. Orders will specify the quantity of each fabrication number to be supplied.

The Agency reserves the right to order additional signs with messages not currently specified in the MUTCD (non-standard messages). Such signs shall be indicated on the order. The size, font type, spacing, and layout of the text on such signs shall be in conformance with the recommendations of the MUTCD. When such non-standard

REQUEST FOR QUOTATION
Portable Sign Stands and Reflective Roll-Up Signs

message signs are ordered, the Vendor shall provide electronic shop drawings of these signs by email to the Agency for approval prior to proceeding with fabrication.

3.4.56 Item 53 – 36’x36’ DIAMOND, FLUORESCENT PINK, STANDARD MESSAGE ROLL-UP SIGN WITH HOOK & LOOP STRIPS FOR OVERLAY ATTACHEMENTS

Items supplied as part of Bid Item 53 shall be standard message (as shown in the WVDOH Sign Fabrication Details) fl-pink and black 36”x36” diamond shaped construction zone warning signs with the addition of 2 to 4 ea. 21” long x 1/2” wide pink H&L strips to be glued or sewn onto the sign face. The H&L strips shall be installed horizontally and parallel to one another, with the measured distance between the outside edges of the strips to be 6”. The mid-point along (10-1/2”) and between (3”) the strips shall be centered vertically and horizontally about the portion of text in the sign specified. The text portions of the signs shall be black, and the background portions shall be fl-pink. Rib sizes, rib locations, rib lengths, corner pocket locations, and rotation point location shall be in substantial conformance as shown in the attached drawing (Exhibit E) “36” DIAMOND – CORNER POCKET AND RIB CONFIGURATION”.

For further guidance, included as part of this Contract is a listing of individual signs with which supplemental overlay plaques are frequently used (Exhibit CC). For each sign with multiple possible messages through the use of overlay plaques, this listing specifies a “base” sign message. Each sign ordered with H&L in order to incorporate overlay plaques shall be manufactured with the “base” sign message as the permanent message on the sign. All 36” signs ordered which may potentially be altered with overlay plaques shall be ordered with H&L strips under this Item number.

Orders will specify the quantity of each fabrication number to be supplied.

The Agency reserves the right to order additional signs with messages not currently specified in the MUTCD (non-standard messages). Such signs shall be indicated on the order. The size, font type, spacing, and layout of the text on such signs shall be in conformance with the recommendations of the MUTCD. When such non-standard message signs are ordered, the Vendor shall provide electronic shop drawings of these signs by email to the Agency for approval prior to proceeding with fabrication.

3.4.57 Item 54 – 8”x21” (“LEFT” AND “CENTER” TEXT ONLY) OR 8”x28” FLUORESCENT PINK OVERLAYS WITH HOOK & LOOP STRIPS FOR USE WITH ITEM 52. EXAMPLES; LEFT, 500 FT., 1000 FT., 1500 FT., ½ MILE, AND 1 MILE

Items supplied as part of Bid Item 54 shall be individual message plaques intended to be attached to the face of signs supplied under Bid Item 52. The text portions of the plaques shall be black, and the background portions shall be fl-pink. The overall size of each individual plaque, with the exception of “LEFT” and “CENTER” plaques, shall be 8” tall x 28” wide. “LEFT” and “CENTER” plaques shall be 8” tall x 23” wide. Text shall be 7” Series C. Text shall be centered vertically and horizontally in each plaque. 2 ea. 28” (23” in the case of “LEFT” or “CENTER” plaque) long x 1/2” wide pieces of H&L shall be glued or sewn onto the back face of each plaque, with 1 ea. of the pieces along the top and bottom edges of the plaque, and with the outside edge of each piece along the outside

REQUEST FOR QUOTATION
Portable Sign Stands and Reflective Roll-Up Signs

edge of the plaque. Orders will specify the quantity of each individual plaque to be supplied.

Note, "AHEAD" plaques shall not be manufactured or supplied under this Item number.

3.4.58 Item 55 – 6"x21" FLUORESCENT PINK OVERLAYS WITH HOOK & LOOP STRIPS FOR USE WITH ITEM NUMBER 53. EXAMPLES: LEFT, 500 FT., 1000 FT., 1500 FT., ½ MILE, 1 MILE, AND AHEAD

Items supplied as part of Bid Item 55 shall be individual message plaques intended to be attached to the face of signs supplied under Bid Item 53. The text portions of the plaques shall be black, and the background portions shall be fl-orange. The overall size of each individual plaque shall be 6" tall x 21" wide. Text shall be 5" Series C. Text shall be centered vertically and horizontally in each plaque. 2 ea. 21" long x ½" wide pieces of H&L shall be glued or sewn onto the back face of each plaque, with 1 ea. of the pieces along the top and bottom edges of the plaque, and with the outside edge of each piece along the outside edge of the plaque. Orders will specify the quantity of each individual plaque to be supplied.

3.5 Sheeting Manufacturer Certification

Bids submitted for this RFQ should include a letter of assurance which addresses reflective sheeting manufacturing and handling procedures. No Vendor shall be awarded any portion of this Contract which includes reflective signs without receipt of this letter by the Division, if required. This letter shall be addressed from the sheeting manufacturer to the manufacturer of the product to be supplied as part of this Contract. If the Vendor intends to utilize different manufacturers for different applicable products and/or different sheeting manufacturers, multiple letters may be required. The language of the letter shall provide sufficient indication, in the Division's judgment, that the reflective sheeting manufacturer has reviewed the recommended handling and manufacturing procedures for the reflective sheeting material with the product manufacturer. The sole purpose of this requirement is for the Division to verify that a) the sheeting manufacturer is aware of the product manufacturer's recommended handling and manufacturing procedures, and b) that the sheeting manufacturer has made the product manufacturer aware of the recommended procedures for handling and manufacturing with the reflective material. If, during the life of the Contract, the product manufacturer intends to begin utilizing a different approved reflective sheeting than originally indicated in the Vendor's RFQ response, the Vendor shall make this request in writing and shall provide a new letter of assurance if determined by the Division to be necessary.

3.6 See Extended Description for each commodity line for that lines requirements.

REQUEST FOR QUOTATION
Portable Sign Stands and Reflective Roll-Up Signs

4 CONTRACT AWARD:

4.1 Contract Award: The Contract is intended to provide Agencies with a purchase price on all Contract Items. The Contract shall be awarded to the Vendor that provides the Contract Items meeting the required specifications for the lowest overall total cost per section on the Pricing Pages. Section I consists of Item 1. Section II consists of Item 2. Section III consists of Items 3 thru 39. Section IV consists of Items 40 through 55. Vendor should complete the pricing pages by providing a unit bid price for all items within each Section that they wish to be considered for award. Vendor should complete the Pricing Pages in their entirety for each Section they wish to be considered for award as failure to do so may result in Vendor's bids being disqualified. All Vendors wishing to be considered for award of Section III of this Contract must provide a bid price for all items within this Section. All Vendors wishing to be considered for award of Section IV of this Contract must provide a bid price for all items within this Section. Each Section shall be evaluated independently and may be awarded to separate vendors.

The Pricing Pages contain a list of the Contract Items and estimated purchase volume. The estimated purchase volume for each item represents the approximate volume of anticipated purchases only. No future use of the Contract or any item is guaranteed or implied.

Vendor should electronically enter the information into the Pricing Pages through wvOASIS, if available, or as an electronic document. In most cases, the Vendor can request an electronic copy of the Pricing Pages for bid purposes by sending an email request to the following address: Crystal.G.Rink@wv.gov .

The Vendor shall complete the Product Compliance Checklist Forms (Exhibit B) included as part of this RFQ in their entirety. These forms should be submitted with the Vendor's bid. No award shall be made to a vendor without the receipt of the applicable Product Compliance Checklist Form(s). This requirement does not apply to portions of the Contract that the Vendor chooses to not bid, and as allowed for as noted on the Product Compliance Checklist Forms (Item #1, Item #2, and/or Items 3 through 39).

4.2 Low Bidder Sample Sign Submittal: As part of the review of bids for this Contract, the Division may, at its' discretion, require bidders being considered for award

REQUEST FOR QUOTATION
Portable Sign Stands and Reflective Roll-Up Signs

as part of Sections III and IV of the Contract to submit sample signs for review. If required, the bidder(s) will be required to submit one or more of the following signs:

Section III

- 1 ea. Item #3
- 1 ea. Item #11
- 2 ea. Item #12 (1 ea. "4", 1 ea. "5")
- 1 ea. Item #34, Fab # W20-5A, H&L positioned to allow "RIGHT" and "1500 FT" to be covered.
- 2 ea. Item #37 (1 ea. "LEFT", 1 ea. "500 FT")

Section IV

- 1 ea. Item #40
- 1 ea. Item #52, Fab # W20-5A, H&L positioned to allow "RIGHT" and "1500 FT" to be covered.
- 2 ea. Item #54 (1 ea. "LEFT", 1 ea. "500 FT")

The bidder(s) will be required to submit the signs requested within ten (10) working days of notification. Failure to supply the requested signs within this time frame may result in the disqualification of the vendor's bid. Samples are to be delivered to the following address:

WVDOH-Traffic Engineering Division
Traffic Services Complex
180 Dry Branch Dr.
Charleston, WV 25306
ATTN: Bruce Miller

5 ORDERING AND PAYMENT:

5.1 Ordering: Vendor shall accept orders through wvOASIS, regular mail, facsimile, e-mail, or any other written forms of communication. Vendor may, but is not required to, accept on-line orders through a secure internet ordering portal/website. If Vendor has the ability to accept on-line orders, it should include in its response a brief description of how Agencies may utilize the on-line ordering system. Any on-line ordering system must have the capability to restrict prices and available items to conform to the Catalog originally submitted with this RFQ. Vendor shall ensure that its on-line ordering system is properly secured prior to processing Agency orders on-line.

REQUEST FOR QUOTATION
Portable Sign Stands and Reflective Roll-Up Signs

5.2 Payment: Vendor shall accept payment in accordance with the payment procedures of the State of West Virginia.

6 DELIVERY AND RETURN:

6.1 Delivery Time: Vendor shall deliver standard orders within 35 working days after orders are received. Vendor shall ship all orders in accordance with the above schedule and shall not hold orders until a minimum delivery quantity is met.

6.2 Late Delivery: The Agency placing the order under this Contract must be notified in writing if orders will be delayed for any reason. Any delay in delivery that could cause harm to an Agency will be grounds for cancellation of the delayed order, and/or obtaining the items ordered from a third party.

Regardless of whether or not the vendor provides written notification of an order delay, if the Vendor is unable to deliver in full within thirty-five (35) Working Days after receipt of the order, the Vendor shall be subject to a daily (per Calendar Day) penalty at the purchasing Agency's discretion for each Calendar Day beyond the delivery deadline date until the order is received in full. This penalty shall be assessed by subtracting the penalty from the original total value of the Release Order. The penalty shall be calculated based on the Table shown at the following address:

<http://www.transportation.wv.gov/highways/contractadmin/specifications/Pages/LiquidDatedDamages.aspx>

The original total amount of the Release Order shall be substituted for the "Original Contract Amount" when using this table.

Any Agency seeking to obtain items from a third party under this provision must first obtain approval of the Purchasing Division.

6.3 Delivery Payment/Risk of Loss: Standard order delivery shall be F.O.B. destination to the Agency's location. Vendor shall include the cost of standard order delivery charges in its bid pricing/discount and is not permitted to charge the Agency separately for such delivery. The Agency will pay delivery charges on all emergency orders provided that Vendor invoices those delivery costs as a separate charge with the original freight bill attached to the invoice.

6.4 Return of Unacceptable Items: If the Agency deems the Contract Items to be unacceptable, the Contract Items shall be returned to Vendor at Vendor's expense and with no restocking charge. Vendor shall either make arrangements

REQUEST FOR QUOTATION
Portable Sign Stands and Reflective Roll-Up Signs

for the return within five (5) days of being notified that items are unacceptable, or permit the Agency to arrange for the return and reimburse Agency for delivery expenses. If the original packaging cannot be utilized for the return, Vendor will supply the Agency with appropriate return packaging upon request. All returns of unacceptable items shall be F.O.B. the Agency's location. The returned product shall either be replaced, or the Agency shall receive a full credit or refund for the purchase price, at the Agency's discretion.

- 6.5 Return Due to Agency Error:** Items ordered in error by the Agency will be returned for credit within 30 days of receipt, F.O.B. Vendor's location. Vendor shall not charge a restocking fee if returned products are in a resalable condition. Items shall be deemed to be in a resalable condition if they are unused and in the original packaging. Any restocking fee for items not in a resalable condition shall be the lower of the Vendor's customary restocking fee or 5% of the total invoiced value of the returned items.

7 VENDOR DEFAULT:

7.1 The following shall be considered a vendor default under this Contract.

- 7.1.1** Failure to provide Contract Items in accordance with the requirements contained herein.
- 7.1.2** Failure to comply with other specifications and requirements contained herein.
- 7.1.3** Failure to comply with any laws, rules, and ordinances applicable to the Contract Services provided under this Contract.
- 7.1.4** Failure to remedy deficient performance upon request.

7.2 The following remedies shall be available to Agency upon default.

- 7.2.1** Immediate cancellation of the Contract.
- 7.2.2** Immediate cancellation of one or more release orders issued under this Contract.

REQUEST FOR QUOTATION
Portable Sign Stands and Reflective Roll-Up Signs

7.2.3 Any other remedies available in law or equity.

8 MISCELLANEOUS:

- 8.1 No Substitutions:** Vendor shall supply only Contract Items submitted in response to the RFQ unless a contract modification is approved in accordance with the provisions contained in this Contract.
- 8.2 Vendor Supply:** Vendor must carry sufficient inventory of the Contract Items being offered to fulfill its obligations under this Contract. By signing its bid, Vendor certifies that it can supply the Contract Items contained in its bid response.
- 8.3 Reports:** Vendor shall provide quarterly reports and annual summaries to the Agency showing the Agency's items purchased, quantities of items purchased, and total dollar value of the items purchased. Vendor shall also provide reports, upon request, showing the items purchased during the term of this Contract, the quantity purchased for each of those items, and the total value of purchases for each of those items. Failure to supply such reports may be grounds for cancellation of this Contract.
- 8.4 Contract Manager:** During its performance of this Contract, Vendor must designate and maintain a primary contract manager responsible for overseeing Vendor's responsibilities under this Contract. The Contract manager must be available during normal business hours to address any customer service or other issues related to this Contract. Vendor should list its Contract manager and his or her contact information below.

Contract Manager: Vicki Shoemaker
Telephone Number: 304-453-5636
Fax Number: 304-453-5635
Email Address: highway_safety @ zoominternet.net

BID SCHEDULE

The following estimated quantities are for bid purposes only. Actual quantities will be determined by needs of the West Virginia Division of Highways and may be increased or decreased:

Item Number	Estimated Quantity	Unit of Measure	Description	Inventory Subcode (DOH USE)	Unit Cost	Total
STAND PORTION						
1	600	Each	EA., COMPACT PORTABLE SIGN STAND			
2	50	Each	EA., LARGE, ALUMINUM SUBSTRATE SIGN AND OVERSIZED ROLL-UP SIGN PORTABLE SIGN STAND	080508	72.11	43,266.00
				080509	98.23	4,911.50
FLUORESCENT ORANGE SIGN PORTION						
3	1	Each	EA, 36" R1-1F "STOP" sign	010107	78.94	78.94
4	5	Each	EA, 48" R1-1F "STOP" sign	010108	131.29	656.45
5	1	Each	EA, 36" W3-1MF SYMBOLIC "STOP AHEAD" sign		86.12	86.12
6	5	Each	EA, 48" W3-1MF SYMBOLIC "STOP AHEAD" sign	020309	134.73	673.65
7	1	Each	EA, 36" R1-2F "YIELD" sign		61.88	61.88
8	30	Each	EA, 48" R1-2F "YIELD" sign	010114	114.64	3439.20
9	1	Each	EA, 36" W3-2MF SYMBOLIC "YIELD AHEAD" sign		86.12	86.12
10	5	Each	EA, 48" W3-2MF SYMBOLIC "YIELD AHEAD" sign		134.72	673.60
11	10	Each	EA., 36" x 60" R2-1MF "WORK ZONE SPEED LIMIT _____" W/ HOOK & LOOP FOR NUMERAL OVERLAY PLAQUES (ORDER NUMERALS UNDER ITEM #12)	010289	110.51	1105.10

ORDERING NOTES FOR DOH PERSONNEL:

FL-ORANGE DIAMOND SIGNS BEGINNING WITH TEXT "ROAD WORK" ARE TO BE ORDERED UNDER ITEM NUMBERS 30, 32, 34, OR 36 ONLY. W20-7A AND W21-1A SIGNS ARE TO BE ORDERED UNDER ITEM NUMBERS 30 OR 32 OR ITEM #24 IS TO BE INSTALLED ONLY ON THE STAND PROVIDED UNDER ITEM #2.

SEE ATTACHED COMMISSIONERS ORDERS REGARDING THE PROPER USE OF ITEM # 11. BASED ON THESE COMMISSIONER'S ORDERS, THIS ITEM MAY BE USED ONLY ON CONTROLLED ACCESS FREEWAYS OR EXPRESSWAYS WHEN THE DURATION OF THE OF THE WORK ACTIVITY IS NOT TO EXCEED ONE DAYLIGHT PERIOD.

THE STAND SUPPLIED AS PART OF BID ITEM #2 IS NOT TO BE USED WITH ALUM SUBSTRATE SIGNS LARGER THAN 48X48 (DIAMOND), 60X30 (HORIZONTAL RECTANGLE), 36X60 (VERTICAL RECTANGLE), 48" (OCTAGON), 48" (SQUARE), OR 48" (TRIANGLE). CONTACT DT FOR SPECIAL NEEDS.

ALL DIAMOND SHAPED SIGNS WHICH MAY POTENTIALLY BE ALTERED WITH OVERLAY PLAQUES ARE TO BE ORDERED WITH HOOK AND LOOP STRIPS UNDER ITEM NUMBERS 33, 34, 35, AND 36. SEE ATTACHED "SUPPLEMENTAL ROLL-UP SIGN ORDERING INFORMATION" SHEET FOR FURTHER GUIDANCE.

ITEMS 40 THROUGH 61 INCIDENT MANAGEMENT SIGNS ARE ONLY TO BE ORDERED AS DIRECTED AND COORDINATED BY THE TRAFFIC ENGINEERING DIVISION CENTRAL OFFICE

Item Number	Estimated Quantity	Unit of Measure	Description	Inventory Subcode (DOH USE)	Unit Cost	Total
12	1	Each	EA., 14" X 17" NUMERAL OVERLAY PLAQUES FOR ITEM NUMBER 11 (SPECIFY QTY OF EACH INDIVIDUAL NUMERAL TO BE SUPPLIED)		14.63	14.63
13	10	Each	EA., 48" X 24" R4-14(L/R)F "ALL TRAFFIC (W/ INTERCHANGEABLE ARROW HEAD)"	010458	61.09	610.90
14	1	Each	EA, 24"x30" R4-7BF "KEEP RIGHT" SIGN		47.65	47.65
15	1	Each	EA, 36"x48" R4-7BF "KEEP RIGHT" SIGN		75.57	75.57
16	1	Each	EA., 30"x18" R9-9F "SIDEWALK CLOSED"		45.24	45.24
17	50	Each	EA., 48"x30" R11-2F "ROAD CLOSED" W/ HOOK & LOOP FOR OVERLAY PLAQUES (ORDER "BRIDGE" AND "RAMP" OVERLAYS UNDER ITEM #18)	011110	67.70	3385.00
18	50	Each	EA., 10" X 39" "BRIDGE" AND "RAMP" OVERLAY PLAQUES FOR ITEM 17 (SPECIFY QTY OF EACH INDIVIDUAL PLAQUE TO BE SUPPLIED)	011112 (BRIDGE) 011113 (RAMP)	18.29	914.50
19	10	Each	EA., 60" X 30" R11-3AF "ROAD CLOSED _____ MI AHEAD LOCAL TRAFFIC ONLY" W/ HOOK & LOOP FOR NUMERAL OVERLAY PLAQUES (ORDER NUMERALS UNDER ITEM #20)	011128	79.96	799.60
20	40	Each	EA., 5" X 7" NUMERAL OVERLAY PLAQUES FOR ITEM NUMBER 19 (SPECIFY QTY OF EACH INDIVIDUAL NUMERAL TO BE SUPPLIED)		7.32	292.80
21	10	Each	EA., 60"x30" R11-4F "ROAD CLOSED TO THRU TRAFFIC"	011135	82.05	820.50
22	1	Each	EA., 48"x36" W22-10F "EXIT _____ " W/ HOOK & LOOP FOR OVERLAYS (ORDER "OPEN" AND "CLOSED" PLAQUES UNDER ITEM #23)	022260	89.35	89.35
23	1	Each	EA., 10" X 40" "OPEN" AND "CLOSED" OVERLAY PLAQUES FOR ITEM 22 (SPECIFY QTY OF EACH INDIVIDUAL PLAQUE TO BE SUPPLIED)	022261 (OPEN) 022262 (CLOSED)	15.90	15.90

ORDERING NOTES FOR DOH PERSONNEL:

FL-ORANGE DIAMOND SIGNS BEGINNING WITH TEXT "ROAD WORK" ARE TO BE ORDERED UNDER ITEM NUMBERS 30, 32, 34, OR 36 ONLY. W20-7A AND W21-1A SIGNS ARE TO BE ORDERED UNDER ITEM NUMBERS 30 OR 32 OR ITEM #24 IS TO BE INSTALLED ONLY ON THE STAND PROVIDED UNDER ITEM #2.

SEE ATTACHED COMMISSIONERS ORDERS REGARDING THE PROPER USE OF ITEM # 11. BASED ON THESE COMMISSIONER'S ORDERS, THIS ITEM MAY BE USED ONLY ON CONTROLLED ACCESS FREEWAYS OR EXPRESSWAYS WHEN THE DURATION OF THE OF THE WORK ACTIVITY IS NOT TO EXCEED ONE DAYLIGHT PERIOD.

THE STAND SUPPLIED AS PART OF BID ITEM #2 IS NOT TO BE USED WITH ALUM SUBSTRATE SIGNS LARGER THAN 48X48 (DIAMOND), 60X30 (HORIZONTAL RECTANGLE), 36X60 (VERTICAL RECTANGLE), 48" (OCTAGON), 48" (SQUARE), OR 48" (TRIANGLE). CONTACT DT FOR SPECIAL NEEDS.

ALL DIAMOND SHAPED SIGNS WHICH MAY POTENTIALLY BE ALTERED WITH OVERLAY PLAQUES ARE TO BE ORDERED WITH HOOK AND LOOP STRIPS UNDER ITEM NUMBERS 33, 34, 35, AND 36. SEE ATTACHED "SUPPLEMENTAL ROLL-UP SIGN ORDERING INFORMATION" SHEET FOR FURTHER GUIDANCE.

ITEMS 40 THROUGH 61 INCIDENT MANAGEMENT SIGNS ARE ONLY TO BE ORDERED AS DIRECTED AND COORDINATED BY THE TRAFFIC ENGINEERING DIVISION CENTRAL OFFICE

Item Number	Estimated Quantity	Unit of Measure	Description	Inventory Subcode (DOH USE)	Unit Cost	Total
24	1	Each	EA., 60"X60" W22-11F EXIT GORE SIGN	022269	189.15	189.15
25	1	Each	EA., 30"X24" M4-9F STANDARD DETOUR SIGN W/ HOOK & LOOP AND ARROW OVERLAY PLAQUE		62.65	62.65
26	10	Each	EA., 48"X48" EMERGENCY RESPONSE TRAILER DETOUR SIGN W/ HOOK & LOOP FOR OVERLAY PLAQUES AND ARROW OVERLAY PLAQUE (ORDER ROUTE AND CARDINAL DIRECTION PLAQUES UNDER ITEM NUMBERS 27 & 28)	114848	117.04	1170.40
27	30	Each	EA., 9" X 28" EMERGENCY RESPONSE TRAILER ROUTE OVERLAY PLAQUE FOR ITEM 26 (SPECIFY EACH INDIVIDUAL ROUTE PLAQUE TO BE SUPPLIED AND QTY OF EACH)	110928	15.52	465.60
28	1	Each	EA., 9" X 7" EMERGENCY RESPONSE TRAILER CARDINAL DIRECTION OVERLAY PLAQUE FOR ITEM 26 (SPECIFY QTY OF EACH "N", "S", "E", AND "W" PLAQUES TO BE SUPPLIED)	110709	12.80	12.80
29	35	Each	Ea., 48" x 48" DIAMOND, FLUORESCENT ORANGE, STANDARD MESSAGE ROLL-UP SIGN (SPECIFY QUANTITY OF EACH FABRICATION NUMBER TO BE SUPPLIED)		96.66	3383.10
30	570	Each	Ea., 48" x 48" DIAMOND, FLUORESCENT ORANGE, STANDARD MESSAGE ROLL-UP SIGN, W/ PERMANENT ADDITION OF TWO (2) 18" X 18" VINYL FOLDING FLAGS. (SPECIFY QUANTITY OF EACH FABRICATION NUMBER TO BE SUPPLIED)		100.65	57,370.50
31	640	Each	Ea., 36" x 36" DIAMOND, FLUORESCENT ORANGE, STANDARD MESSAGE ROLL-UP SIGN (SPECIFY QUANTITY OF EACH FABRICATION NUMBER TO BE SUPPLIED)		55.97	35,820.80
32	750	Each	Ea., 36" x 36" DIAMOND, FLUORESCENT ORANGE, STANDARD MESSAGE ROLL-UP SIGN, WITH PERMANENT ADDITION OF TWO (2) 18"X18" VINYL FOLDING FLAGS . (SPECIFY QUANTITY OF EACH FABRICATION NUMBER TO BE SUPPLIED)		62.62	46,965.00
33	85	Each	Ea., 48" x 48" DIAMOND, FLUORESCENT ORANGE, STANDARD MESSAGE ROLL-UP SIGN WITH HOOK & LOOP STRIPS FOR OVERLAY ATTACHMENTS (SPECIFY QTY OF EACH FABRICATION NUMBER TO BE SUPPLIED AND PORTION OF TEXT INTENDED TO BE COVERED WITH OVERLAY PLAQUES - ORDER OVERLAY PLAQUES UNDER BID ITEM 37)		99.80	8,483.00

ORDERING NOTES FOR DOH PERSONNEL:

FL-ORANGE DIAMOND SIGNS BEGINNING WITH TEXT "ROAD WORK" ARE TO BE ORDERED UNDER ITEM NUMBERS 30, 32, 34, OR 36 ONLY. W20-7A AND W21-1A SIGNS ARE TO BE ORDERED UNDER ITEM NUMBERS 30 OR 32 OF ITEM #24 IS TO BE INSTALLED ONLY ON THE STAND PROVIDED UNDER ITEM #2.

SEE ATTACHED COMMISSIONERS ORDERS REGARDING THE PROPER USE OF ITEM # 11. BASED ON THESE COMMISSIONER'S ORDERS, THIS ITEM MAY BE USED ONLY ON CONTROLLED ACCESS FREEWAYS OR EXPRESSWA WHEN THE DURATION OF THE OF THE WORK ACTIVITY IS NOT TO EXCEED ONE DAYLIGHT PERIOD.

THE STAND SUPPLIED AS PART OF BID ITEM #2 IS NOT TO BE USED WITH ALUM SUBSTRATE SIGNS LARGER THAN 48X48 (DIAMOND), 60X30 (HORIZONTAL RECTANGLE), 36X60 (VERTICAL RECTANGLE), 48" (OCTAGON), 48" (SQUARE), OR 48" (TRIANGLE). CONTACT DT FOR SPECIAL NEEDS.

ALL DIAMOND SHAPED SIGNS WHICH MAY POTENTIALLY BE ALTERED WITH OVERLAY PLAQUES ARE TO BE ORDERED WITH HOOK AND LOOP STRIPS UNDER ITEM NUMBERS 33, 34, 35, AND 36. SEE ATTACHED "SUPPLEMENTAL ROLL-UP SIGN ORDERING INFORMATION" SHEET FOR FURTHER GUIDANCE.

ITEMS 40 THROUGH 61 INCIDENT MANAGEMENT SIGNS ARE ONLY TO BE ORDERED AS DIRECTED AND COORDINATED BY THE TRAFFIC ENGINEERING DIVISION CENTRAL OFFICE

Item Number	Estimated Quantity	Unit of Measure	Description	Inventory Subcode (DOH USE)	Unit Cost	Total
34	175	Each	Ea., 48" x 48" DIAMOND, FLUORESCENT ORANGE, STANDARD MESSAGE ROLL-UP SIGN WITH PERMANENT ADDITION OF TWO (2) 18"X18" VINYL FOLDING FLAGS, AND HOOK & LOOP STRIPS FOR OVERLAY ATTACHMENTS (SPECIFY QTY OF EACH FABRICATION NUMBER TO BE SUPPLIED AND PORTION OF TEXT INTENDED TO BE COVERED WITH OVERLAY PLAQUES - ORDER OVERLAY PLAQUES UNDER BID ITEM 37)		103.46	18105.80
35	1	Each	Ea., 36" x 36" DIAMOND, FLUORESCENT ORANGE, STANDARD MESSAGE ROLL-UP SIGN WITH HOOK & LOOP STRIPS FOR OVERLAY ATTACHMENTS (SPECIFY QTY OF EACH FABRICATION NUMBER TO BE SUPPLIED AND PORTION OF TEXT INTENDED TO BE COVERED WITH OVERLAY PLAQUES - ORDER OVERLAY PLAQUES UNDER BID ITEM 38)		64.79	64.79
36	60	Each	Ea., 36" x 36" DIAMOND, FLUORESCENT ORANGE, STANDARD MESSAGE ROLL-UP SIGN WITH PERMANENT ADDITION OF TWO (2) 18"X18" VINYL FOLDING FLAGS, AND HOOK & LOOP STRIPS FOR OVERLAY ATTACHMENTS (SPECIFY QTY OF EACH FABRICATION NUMBER TO BE SUPPLIED AND PORTION OF TEXT INTENDED TO BE COVERED WITH OVERLAY PLAQUES - ORDER OVERLAY PLAQUES UNDER BID ITEM 38)		69.49	4169.40
37	310	Each	Ea., 8" X 21" ("LEFT" AND "CENTER" TEXT ONLY) OR 8" x 28" FLUORESCENT ORANGE OVERLAYS WITH H&L STRIPS FOR USE WITH ITEM NUMBERS 33 AND 34. EXAMPLES: LEFT, 500 FT., 1000 FT., 1500 FT., 1/2 MILE, AND 1 MILE (SPECIFY QUANTITY OF EACH PLAQUE TO BE SUPPLIED)		13.06	4048.60
38	10	Each	Ea., 6" x 21" FLUORESCENT ORANGE OVERLAYS WITH H&L STRIPS FOR USE WITH ITEM NUMBERS 35 AND 36. EXAMPLES: LEFT, 500 FT., 1000 FT., 1500 FT., 1/2 MILE, 1 MILE, and AHEAD (SPECIFY QUANTITY OF EACH PLAQUE TO BE SUPPLIED)		11.50	115.00
39	1	Each	EA, 18"x36" G20-2 "END ROAD WORK" SIGN		55.67	55.67

ORDERING NOTES FOR DOH PERSONNEL:

FL-ORANGE DIAMOND SIGNS BEGINNING WITH TEXT "ROAD WORK" ARE TO BE ORDERED UNDER ITEM NUMBERS 30, 32, 34, OR 36 ONLY. W20-7A AND W21-1A SIGNS ARE TO BE ORDERED UNDER ITEM NUMBERS 30 OR 32 OF

ITEM #24 IS TO BE INSTALLED ONLY ON THE STAND PROVIDED UNDER ITEM #2.

SEE ATTACHED COMMISSIONERS ORDERS REGARDING THE PROPER USE OF ITEM # 11. BASED ON THESE COMMISSIONER'S ORDERS, THIS ITEM MAY BE USED ONLY ON CONTROLLED ACCESS FREEWAYS OR EXPRESSWAYS WHEN THE DURATION OF THE OF THE WORK ACTIVITY IS NOT TO EXCEED ONE DAYLIGHT PERIOD.

THE STAND SUPPLIED AS PART OF BID ITEM #2 IS NOT TO BE USED WITH ALUM SUBSTRATE SIGNS LARGER THAN 48X48 (DIAMOND), 60X30 (HORIZONTAL RECTANGLE), 36X60 (VERTICAL RECTANGLE), 48" (OCTAGON), 48" (SQUARE), OR 48" (TRIANGLE). CONTACT DT FOR SPECIAL NEEDS.

ALL DIAMOND SHAPED SIGNS WHICH MAY POTENTIALLY BE ALTERED WITH OVERLAY PLAQUES ARE TO BE ORDERED WITH HOOK AND LOOP STRIPS UNDER ITEM NUMBERS 33, 34, 35, AND 36. SEE ATTACHED "SUPPLEMENTAL ROLL-UP SIGN ORDERING INFORMATION" SHEET FOR FURTHER GUIDANCE.

ITEMS 40 THROUGH 61 INCIDENT MANAGEMENT SIGNS ARE ONLY TO BE ORDERED AS DIRECTED AND COORDINATED BY THE TRAFFIC ENGINEERING DIVISION CENTRAL OFFICE

FLUORESCENT PINK SIGN PORTION						
Item Number	Estimated Quantity	Unit of Measure	Description	Inventory Subcode (DOH USE)	Unit Cost	Total
40	1	Each	EA, 36" W3-1MF SYMBOLIC "STOP AHEAD" sign, fluorescent-pink		54.82	54.82
41	1	Each	EA, 48" W3-1MF SYMBOLIC "STOP AHEAD" sign, fluorescent-pink		77.59	77.59
42	1	Each	EA, 36" W3-2MF SYMBOLIC "YIELD AHEAD" sign, fluorescent-pink		54.82	54.82
43	1	Each	EA, 48" W3-2MF SYMBOLIC "YIELD AHEAD" sign, fluorescent-pink		77.59	77.59
44	1	Each	EA., 48"X36" W22-10F "EXIT _____" W/ HOOK & LOOP FOR OVERLAYS, fluorescent-pink (ORDER "OPEN" AND "CLOSED" PLAQUES UNDER ITEM #51)		52.52	52.52
45	1	Each	EA., 10" X 40" "OPEN" AND "CLOSED" OVERLAY PLAQUES FOR ITEM 50, fluorescent-pink (SPECIFY QTY OF EACH INDIVIDUAL PLAQUE TO BE SUPPLIED)		11.50	11.50
46	1	Each	EA., 30"X24" M4-9F STANDARD DETOUR SIGN W/ HOOK & LOOP AND ARROW OVERLAY PLAQUE, fluorescent-pink		39.89	39.89

ORDERING NOTES FOR DOH PERSONNEL:

FL-ORANGE DIAMOND SIGNS BEGINNING WITH TEXT "ROAD WORK" ARE TO BE ORDERED UNDER ITEM NUMBERS 30, 32, 34, OR 36 ONLY. W20-7A AND W21-1A SIGNS ARE TO BE ORDERED UNDER ITEM NUMBERS 30 OR 32 OR ITEM #24 IS TO BE INSTALLED ONLY ON THE STAND PROVIDED UNDER ITEM #2.

SEE ATTACHED COMMISSIONERS ORDERS REGARDING THE PROPER USE OF ITEM # 11. BASED ON THESE COMMISSIONER'S ORDERS, THIS ITEM MAY BE USED ONLY ON CONTROLLED ACCESS FREEWAYS OR EXPRESSWAYS WHEN THE DURATION OF THE OF THE WORK ACTIVITY IS NOT TO EXCEED ONE DAYLIGHT PERIOD.

THE STAND SUPPLIED AS PART OF BID ITEM #2 IS NOT TO BE USED WITH ALUM SUBSTRATE SIGNS LARGER THAN 48X48 (DIAMOND), 60X30 (HORIZONTAL RECTANGLE), 36X60 (VERTICAL RECTANGLE), 48" (OCTAGON), 48" (SQUARE), OR 48" (TRIANGLE). CONTACT DT FOR SPECIAL NEEDS.

ALL DIAMOND SHAPED SIGNS WHICH MAY POTENTIALLY BE ALTERED WITH OVERLAY PLAQUES ARE TO BE ORDERED WITH HOOK AND LOOP STRIPS UNDER ITEM NUMBERS 33, 34, 35, AND 36. SEE ATTACHED "SUPPLEMENTAL ROLL-UP SIGN ORDERING INFORMATION" SHEET FOR FURTHER GUIDANCE.

ITEMS 40 THROUGH 61 INCIDENT MANAGEMENT SIGNS ARE ONLY TO BE ORDERED AS DIRECTED AND COORDINATED BY THE TRAFFIC ENGINEERING DIVISION CENTRAL OFFICE

Item Number	Estimated Quantity	Unit of Measure	Description	Inventory Subcode (DOH USE)	Unit Cost	Total
47	1	Each	EA., 48"X48" EMERGENCY RESPONSE TRAILER DETOUR SIGN W/ HOOK & LOOP FOR OVERLAY PLAQUES AND ARROW OVERLAY PLAQUE, fluorescent-pink (ORDER ROUTE AND CARDINAL DIRECTION PLAQUES UNDER ITEM NUMBERS 54 & 55)		70.28	70.28
48	1	Each	EA., 9" X 28" EMERGENCY RESPONSE TRAILER ROUTE OVERLAY PLAQUE FOR ITEM 53, fluorescent-pink (SPECIFY EACH INDIVIDUAL ROUTE PLAQUE TO BE SUPPLIED AND QTY OF EACH)		11.50	11.50
49	1	Each	EA., 9" X 7" EMERGENCY RESPONSE TRAILER CARDINAL DIRECTION OVERLAY PLAQUE FOR ITEM 53, fluorescent-pink (SPECIFY QTY OF EACH "N", "S", "E", AND "W" PLAQUES TO BE SUPPLIED)		8.36	8.36
50	1	Each	Ea., 48" x 48" DIAMOND, FLUORESCENT PINK, STANDARD MESSAGE ROLL-UP SIGN (SPECIFY QUANTITY OF EACH FABRICATION NUMBER TO BE SUPPLIED)		67.14	67.14
51	1	Each	Ea., 36" x 36" DIAMOND, FLUORESCENT PINK, STANDARD MESSAGE ROLL-UP SIGN (SPECIFY QUANTITY OF EACH FABRICATION NUMBER TO BE SUPPLIED)		43.51	43.51
52	1	Each	Ea., 48" x 48" DIAMOND, FLUORESCENT PINK, STANDARD MESSAGE ROLL-UP SIGN WITH HOOK & LOOP STRIPS FOR OVERLAY ATTACHMENTS (SPECIFY QTY OF EACH FABRICATION NUMBER TO BE SUPPLIED AND PORTION OF TEXT INTENDED TO BE COVERED WITH OVERLAY PLAQUES - ORDER OVERLAY PLAQUES UNDER BID ITEM 54)		67.14	67.14
53	1	Each	Ea., 36" x 36" DIAMOND, FLUORESCENT PINK, STANDARD MESSAGE ROLL-UP SIGN WITH HOOK & LOOP STRIPS FOR OVERLAY ATTACHMENTS (SPECIFY QTY OF EACH FABRICATION NUMBER TO BE SUPPLIED AND PORTION OF TEXT INTENDED TO BE COVERED WITH OVERLAY PLAQUES - ORDER OVERLAY PLAQUES UNDER BID ITEM 55)		47.14	47.14
54	1	Each	Ea., 8" X 21" ("LEFT" AND "CENTER" TEXT ONLY) OR 8" x 28" FLUORESCENT PINK OVERLAYS WITH H&L STRIPS FOR USE WITH ITEM NUMBER 52. EXAMPLES: LEFT, 500 FT., 1000 FT., 1500 FT., 1/2 MILE, AND 1 MILE (SPECIFY QUANTITY OF EACH PLAQUE TO BE SUPPLIED)		8.36	8.36
55	1	Each	Ea., 6" x 21" FLUORESCENT PINK OVERLAYS WITH H&L STRIPS FOR USE WITH ITEM NUMBER 53. EXAMPLES: LEFT, 500 FT., 1000 FT., 1500 FT., 1/2 MILE, 1 MILE, and AHEAD (SPECIFY QUANTITY OF EACH PLAQUE TO BE SUPPLIED)		8.36	8.36

ORDERING NOTES FOR DOH PERSONNEL:

FL-ORANGE DIAMOND SIGNS BEGINNING WITH TEXT "ROAD WORK" ARE TO BE ORDERED UNDER ITEM NUMBERS 30, 32, 34, OR 36 ONLY. W20-7A AND W21-1A SIGNS ARE TO BE ORDERED UNDER ITEM NUMBERS 30 OR 32 OF ITEM #24 IS TO BE INSTALLED ONLY ON THE STAND PROVIDED UNDER ITEM #2.

SEE ATTACHED COMMISSIONERS ORDERS REGARDING THE PROPER USE OF ITEM # 11. BASED ON THESE COMMISSIONER'S ORDERS, THIS ITEM MAY BE USED ONLY ON CONTROLLED ACCESS FREEWAYS OR EXPRESSWAYS WHEN THE DURATION OF THE OF THE WORK ACTIVITY IS NOT TO EXCEED ONE DAYLIGHT PERIOD.

THE STAND SUPPLIED AS PART OF BID ITEM #2 IS NOT TO BE USED WITH ALUM SUBSTRATE SIGNS LARGER THAN 48X48 (DIAMOND), 60X30 (HORIZONTAL RECTANGLE), 36X60 (VERTICAL RECTANGLE), 48" (OCTAGON), 48" (SQUARE), OR 48" (TRIANGLE). CONTACT DT FOR SPECIAL NEEDS.

ALL DIAMOND SHAPED SIGNS WHICH MAY POTENTIALLY BE ALTERED WITH OVERLAY PLAQUES ARE TO BE ORDERED WITH HOOK AND LOOP STRIPS UNDER ITEM NUMBERS 33, 34, 35, AND 36. SEE ATTACHED "SUPPLEMENTAL ROLL-UP SIGN ORDERING INFORMATION" SHEET FOR FURTHER GUIDANCE.

ITEMS 40 THROUGH 61 INCIDENT MANAGEMENT SIGNS ARE ONLY TO BE ORDERED AS DIRECTED AND COORDINATED BY THE TRAFFIC ENGINEERING DIVISION CENTRAL OFFICE

EXHIBIT A

SPECIAL PROVISIONS

NEXT 21 PAGES

WEST VIRGINIA DEPARTMENT OF TRANSPORTATION

DIVISION OF HIGHWAYS

SPECIAL PROVISION

FOR

SECTION 715

MISCELLANEOUS MATERIALS

715.9-WARNING DEVICES:

715.9.1 – General:

DELETE THIS SECTION AND REPLACE WITH THE FOLLOWING:

715.9.1-General: Warning devices shall include, but shall not be limited to, signs, barricades, auxiliary barriers, channelizing devices, hazard warning lights, flares, and reflectors. Unless otherwise indicated such devices shall conform to the standard, "Manual On Temporary Traffic Control for Streets and Highways ", published by the Division. The Contractor shall exhibit evidence that the warning devices furnished meet the requirements detailed.

715.9.2-Signs:

DELETE THIS SECTION AND REPLACE WITH THE FOLLOWING:

715.9.2-Signs: Sign blank material shall be either 0.080 in. flat sheet aluminum, 0.040 in. flat sheet aluminum (guide sign demountable shields, legend, & border only), or extruded panel as specified in Section 661. Retroreflection shall be required and shall be accomplished by using approved retroreflective sheeting as specified in Section 661 and meeting the requirements specified herein.

All references herein to ASTM specification D4956 shall be interpreted as referencing version D4956 – 11a. Any portion of this specification which is in contradiction to ASTM D4956 shall supersede ASTM D4956. All references herein to AASHTO (American Association of State Highway and Transportation Officials) specification M268 shall be interpreted as referencing version M 268-10. Any portion of this specification which is in contradiction to AASHTO M268 shall supersede AASHTO M268. All AASHTO-NTPEP references herein shall be interpreted as referring to the AASHTO National Transportation Product Evaluation Program (NTPEP). All retroreflectivity values referenced herein shall be in units of $cd/ft^2(cd \cdot lx^{-1} \cdot m^{-2})$. All "matched component" references herein shall be

interpreted as referencing the retroreflective sheeting manufacturer's recommended inks and overlay films to be used for manufacturing purposes with the manufacturer's sheeting. All APL references herein shall be interpreted as referring to the Division's Approved Products List (APL) for Retroreflective Sheeting. All CSS references herein shall be interpreted as referring to the Division's Central Sign Shop (CSS) internal sign manufacturing facility in Charleston, WV.

715.9.2.1-Retroreflective Sheeting, Type ASTM-I: A retroreflective sheeting referred to as "engineering grade" that is typically an enclosed lens glass-bead sheeting.

715.9.2.1.1- Type ASTM-I Sheeting Requirements:

715.9.2.1.1.1- Coefficient of Retroreflection: New sheeting shall meet the Minimum Coefficient of Retroreflection requirements in ASTM specification D4956 for Type I material, as defined in ASTM D4956.

For transparent ink printed or transparent film covered areas over white sheeting, the Minimum Coefficient of Retroreflection requirements shall be seventy (70) % of the values specified in ASTM D4956 for sheeting of the same color as the ink or film.

All testing shall be conducted in accordance with ASTM D4956.

715.9.2.1.1.2- Color: New sheeting shall meet the Daytime Color & Nighttime Color requirements in ASTM specification D4956 when tested in accordance with ASTM specification D4956. These requirements shall also apply to transparent ink and transparent film covered areas over white sheeting.

715.9.2.1.1.3- Daytime Luminance Factor: New sheeting shall meet the Daytime Luminance Factor requirements in ASTM specification D4956 when tested in accordance with ASTM specification D4956. These requirements shall also apply to transparent ink and transparent film covered areas over white sheeting.

715.9.2.1.1.4- Adhesion: New sheeting with a pressure sensitive backing shall meet the adhesion requirements in ASTM specification D4956 when tested in accordance with ASTM specification D4956.

715.9.2.1.1.5- Shrinkage: New sheeting shall meet the shrinkage requirements in ASTM specification D4956 when tested in accordance with ASTM specification D4956.

715.9.2.1.1.6- Flexibility: New sheeting shall meet the flexibility requirements in ASTM specification D4956 when tested in accordance with ASTM specification D4956.

715.9.2.1.1.7- Liner Removal: New sheeting shall meet the liner removability requirements in ASTM specification D4956 when tested in accordance with ASTM specification D4956.

715.9.2.1.1.8- Impact Resistance: New sheeting shall meet the impact resistance requirements in ASTM specification D4956 when tested in accordance with ASTM specification D4956.

715.9.2.1.1.9-Rotational Sensitivity: New sheeting shall meet the applicable requirements of AASHTO M268 in order for the sheeting to be considered rotationally insensitive. Testing shall be conducted at the viewing geometry of 0.5/-4 as recommended in AASHTO M268, and the results of retroreflectivity readings at rotation angles of 0, 45, 90, and 120 degrees shall be compared as recommended in AASHTO M268. If the sheeting does not meet these requirements, it shall be noted on the APL that the material is rotationally sensitive.

715.9.2.1.1.10- Shelf Life: Any Type ASTM-I material to be considered for listing on the Division's APL shall have a minimum one (1) year shelf life. The same provisions shall apply to the manufacturer recommended matched components. Reasonable conditional requirements pertaining to storage, such as temperature and relative humidity, shall be permitted.

715.9.2.1.1.11- Backing Class: Type ASTM-I sheeting shall have a Class 1 adhesive backing, as defined in ASTM D4956.

715.9.2.1.1.12- Durability: The durability requirements of finished products manufactured using Type ASTM-I sheeting are specified within Section 715.9.2.7.

715.9.2.1.2- Approval Process: The WVDOH approval process for Type ASTM-I sheeting products is specified within Section 715.9.2.9.

715.9.2.2- Retroreflective Sheeting, Type ASTM-IV: A retroreflective sheeting referred to as "high-intensity" that is typically an unmetallized micropismatic retroreflective element material.

715.9.2.2.1- Type ASTM-IV Sheeting Requirements:

715.9.2.2.1.1- Coefficient of Retroreflection: New material shall meet the Minimum Coefficient of Retroreflection requirements in ASTM D4956 for Type IV material, as defined in ASTM D4956.

For transparent ink printed or transparent film covered areas over white sheeting, the Minimum Coefficient of Retroreflection requirements shall be seventy (70) % of the values specified in ASTM D4956 for sheeting of the same color as the ink or film.

All testing shall be conducted in accordance with ASTM D4956.

715.9.2.2.1.2- Color: New sheeting shall meet the Daytime Color & Nighttime Color requirements in ASTM specification D4956 when tested in accordance with ASTM specification D4956. These requirements shall also apply to transparent ink and transparent film covered areas over white sheeting.

715.9.2.2.1.3- Daytime Luminance Factor: New sheeting shall meet the Daytime Luminance Factor requirements in specification D4956 when tested in accordance with ASTM specification D4956. These requirements shall also apply to transparent ink and transparent film covered areas over white sheeting.

715.9.2.2.1.4- Adhesion: New sheeting shall meet the adhesion requirements in specification D4956 when tested in accordance with ASTM specification D4956. If the material is marketed as a reboundable material, the supplementary adhesion requirements in ASTM D4956 for reboundable materials shall apply.

715.9.2.2.1.5- Shrinkage: New sheeting shall meet the shrinkage requirements in ASTM specification D4956 when tested in accordance with ASTM specification D4956.

715.9.2.2.1.6- Flexibility: New sheeting shall meet the flexibility requirements in ASTM specification D4956 when tested in accordance with ASTM specification D4956. If the material is marketed as a reboundable material, the supplementary flexibility requirements in ASTM D4956 for reboundable materials shall apply.

715.9.2.2.1.7- Liner Removal: New sheeting shall meet the liner removability requirements in ASTM specification D4956 when tested in accordance with ASTM specification D4956.

715.9.2.2.1.8- Impact Resistance: New sheeting shall meet the impact resistance requirements in ASTM specification D4956 when tested in accordance with ASTM specification D4956. If the material is marketed as a reboundable material, the supplementary impact resistance requirements in ASTM D4956 for reboundable materials shall apply.

715.9.2.2.1.9- Rotational Sensitivity: New sheeting materials, with exceptions noted herein, shall meet the applicable requirements of AASHTO M268 in order for the sheeting to be considered rotationally insensitive. Testing shall be conducted at the viewing geometry of 0.5/-4 as recommended in AASHTO M268, and the results of retroreflectivity readings at rotation angles of 0, 45, 90, and 120 degrees shall be compared as recommended in AASHTO M268. If the sheeting does not meet these requirements, it shall be noted on the APL that the material is rotationally sensitive. With the exception of fluorescent-orange materials intended for application to rigid substrate signs, "work zone" materials as defined herein shall not be subject to rotational sensitivity testing.

715.9.2.2.1.10- Shelf Life: A minimum shelf life shall not be required for the sheeting to be listed on the APL. However, in order for the sheeting to be approved for manufacturing purposes within the Division's CSS, a minimum (1) year shelf life shall be required. The same provisions shall apply to the manufacturer recommended matched components. Reasonable conditional requirements pertaining to storage, such as temperature and relative humidity, shall be permitted.

715.9.2.2.1.11- Backing Class: All Type ASTM-IV material supplied to the Division for manufacturing purposes within the CSS shall have a Class 1 adhesive backing, as defined in ASTM D4956. The adhesive backing on all Type ASTM-IV material supplied to manufacturers providing finished products to the Division or to Contractors performing work on Division Contracts shall have the most appropriate ASTM D4956 defined adhesive backing for the materials intended purpose, as determined by the manufacturer.

715.9.2.2.1.12- Durability: Durability requirements of finished products manufactured using Type ASTM-IV to be warranted by the sheeting manufacturer are specified within Section 715.9.2.7.

715.9.2.2.2- Approval Process: The WVDOH approval process for Type ASTM-IV sheeting products is specified within Section 715.9.2.9.

715.9.2.3- Retroreflective Sheeting, Type ASTM-VI: An elastomeric retroreflective sheeting without adhesive. This sheeting is typically a vinyl microprismatic retroreflective material.

715.9.2.3.1- Type ASTM-VI Sheeting Requirements:

715.9.2.3.1.1- Coefficient of Retroreflection: New sheeting shall meet the Minimum Coefficient of Retroreflection requirements as specified in Table 715.9.2.3.1.1-I below.

Observation Angle	Entrance Angle	Color	
		White	Fluorescent- Orange
0.2	-4	300	200
0.2	+30	180	120
0.2	+45	100	60
0.5	-4	200	120
0.5	+30	75	50
0.5	+45	60	30

For transparent ink printed areas over white sheeting, the Minimum Coefficient of Retroreflection requirements shall be as shown in Table 715.9.2.3.1.1-II below.

Observation Angle	Entrance Angle	Color				
		Green	Blue	Red	Yellow	Brown
0.2	-4	21	9.5	29	147	6.1

All testing shall be conducted in accordance with ASTM D4956.

715.9.2.3.1.2- Color: New sheeting shall meet the Daytime Color & Nighttime Color requirements in ASTM specification D4956 when tested in accordance with ASTM specification D4956. These same requirements shall apply to transparent ink covered areas over white sheeting.

715.9.2.3.1.3- Daytime Luminance Factor: New sheeting shall meet the Daytime Luminance Factor requirements of ASTM specification D4956 when tested in accordance with ASTM specification D4956. These requirements shall also apply to transparent ink covered areas over white sheeting.

715.9.2.3.1.4- Shrinkage: New sheeting shall meet the shrinkage requirements in ASTM specification D4956 when tested in accordance with ASTM specification D4956.

715.9.2.3.1.5- Flexibility: New sheeting shall meet the flexibility requirements in ASTM specification D4956 when tested in accordance with ASTM specification D4956.

715.9.2.3.1.6- Impact Resistance: New sheeting shall meet the impact resistance requirements in ASTM specification D4956 when tested in accordance with ASTM specification D4956.

715.9.2.3.1.7- BLANK

715.9.2.3.1.8- Backing Class: All Type ASTM-VI material shall have a Class 5 backing, as defined in ASTM D4956.

715.9.2.3.1.9- Durability: Durability requirements of finished products manufactured using Type ASTM-VI material to be warranted by the sheeting manufacturer are specified within Section 715.9.2.7.

715.9.2.3.2- Approval Process: The WVDOH approval process for Type ASTM-VI sheeting products is specified within Section 715.9.2.9.

715.9.2.4- Retroreflective Sheeting, Type ASTM-XI: A retroreflective sheeting typically manufactured as an unmetalized cube corner microprismatic retroreflective element material.

715.9.2.4.1- Type ASTM-XI Sheeting Requirements:

715.9.2.4.1.1- Coefficient of Retroreflection: New sheeting shall meet the Minimum Coefficient of Retroreflection requirements in ASTM specification D4956 for Type XI material, as defined in ASTM D4956.

For transparent ink printed or transparent film covered areas over white sheeting, the Minimum Coefficient of Retroreflection requirements shall be seventy (70) % of the values specified in ASTM D4956 for sheeting of the same color as the ink or film.

All testing shall be conducted in accordance with ASTM D4956.

715.9.2.4.1.2- Color: New sheeting shall meet the Daytime Color & Nighttime Color requirements in ASTM specification D4956 when tested in accordance with ASTM specification D4956. These same requirements shall apply to transparent ink and transparent film covered areas over white sheeting.

715.9.2.4.1.3- Daytime Luminance Factor: New sheeting shall meet the Daytime Luminance Factor requirements in ASTM specification D4956 when tested in accordance with ASTM specification D4956. These same requirements shall apply to transparent ink and transparent film covered areas over white sheeting.

715.9.2.4.1.4- Adhesion: New sheeting shall meet the adhesion requirements in ASTM specification D4956 when tested in accordance with ASTM specification D4956. If the material is marketed as a reboundable material, the supplementary adhesion requirements in ASTM D4956 for reboundable materials shall apply.

715.9.2.4.1.5- Shrinkage: New sheeting shall meet the shrinkage requirements in ASTM specification D4956 when tested in accordance with ASTM specification D4956.

715.9.2.4.1.6- Flexibility: New sheeting shall meet the flexibility requirements in ASTM specification D4956 when tested in accordance with ASTM specification D4956. If the material is marketed as a reboundable material, the supplementary flexibility requirements in ASTM D4956 for reboundable materials shall apply.

715.9.2.4.1.7- Liner Removal: New sheeting shall meet the liner removability requirements in ASTM specification D4956 when tested in accordance with ASTM specification D4956.

715.9.2.4.1.8- Impact Resistance: New sheeting shall meet the impact resistance requirements in ASTM specification D4956 when tested in accordance with ASTM specification D4956. If the material is marketed as a reboundable material, the supplementary impact resistance requirements in ASTM D4956 for reboundable materials shall apply.

715.9.2.4.1.9-Rotational Sensitivity: New sheeting materials, with exceptions noted herein, shall meet the applicable requirements of AASHTO M268 in order for the sheeting to be considered rotationally insensitive. Testing shall be conducted at the viewing geometry of 0.5/-4 as recommended in AASHTO M268, and the results of retroreflectivity readings at rotation angles of 0, 45, 90, and 120 degrees shall be compared as recommended in AASHTO M268. If the sheeting does not meet these requirements, it shall be noted on the APL that the material is rotationally sensitive. With the exception of fluorescent-orange materials intended for application to rigid substrate signs, "work zone" materials as defined herein shall not be subject to rotational sensitivity testing.

715.9.2.4.1.10- Shelf Life: A minimum shelf life shall not be required for the sheeting to be listed on the APL. However, in order for the sheeting to be approved for manufacturing purposes within the Division's CSS, a minimum (1) year shelf life shall be required. The same provisions shall apply to the manufacturer recommended matched components. Reasonable conditional requirements pertaining to storage, such as temperature and relative humidity, shall be permitted.

715.9.2.4.1.11- Backing Class: All Type ASTM-XI material supplied to the Division for manufacturing purposes within the CSS shall have a Class 1 adhesive backing, as defined in ASTM D4956. The adhesive backing on all Type ASTM-XI material supplied to manufacturers providing finished products to the Division or to Contractors performing work on Division Contracts shall have the most appropriate ASTM D4956 adhesive backing for the materials intended purpose.

715.9.2.4.1.12- Durability: Durability requirements of finished products manufactured using Type ASTM-XI material to be warranted by the sheeting manufacturer are specified within Section 715.9.2.7.

715.9.2.4.2- Approval Process: The WVDOH approval process for Type ASTM-XI sheeting products is specified within Section 715.9.2.9.

715.9.2.5-Transfer Film: Transfer film for premasking or applying prespaced legends using transparent or opaque films.

715.9.2.5.1 – Transfer Film Requirements:

715.9.2.5.1.1 – Transparency: Transfer films shall be transparent.

715.9.2.5.2 – Approval Process: The WVDOH approval process for Transfer Film is specified within Section 715.9.2.9.

715.9.2.6-Matched Components:

715.9.2.6.1-Black Opaque Overlay Film: A black, opaque, typically vinyl or acrylic pressure-sensitive film designed for permanent graphics that may be prespaced and electronically cut. These films have a synthetic liner that resists moisture absorption and static buildup.

715.9.2.6.1.1-Black Opaque Overlay Film Requirements:

715.9.2.6.1.1.1- Adhesive: This material shall utilize a pressure sensitive adhesive.

715.9.2.6.1.1.2- Chemical Resistance: This material shall resist mild alkalis, mild acids, and salt. The material shall exhibit excellent resistance to water, with exception to cases of submersion.

715.9.2.6.1.1.3- Shrinkage: After application, this material shall not exhibit shrinkage in excess of 0.010 inches.

715.9.2.6.1.1.4- Durability: Durability requirements of black opaque overlay films, depending on the Type sheeting the material is to be utilized with and the intended application, are specified in Sections 715.9.2.1 through 715.9.2.4.

715.9.2.6.1.1.5 – Shelf Life: A minimum shelf life shall not be required for the film to be approved for use with the manufacturer's sheeting products. However, in order for the film to be approved for manufacturing purposes within the Division's CSS, a minimum (1) year shelf life shall be required. Reasonable conditional requirements pertaining to storage, such as temperature and relative humidity, shall be permitted.

715.9.2.6.1.1.6- CSS Requirements: In addition to, but not limited to, any other requirements stated herein, all black opaque overlay film to be approved for manufacturing purposes within the CSS shall be a vinyl material. In addition, this material shall have sufficient strength so that it can be handled, processed, and applied according to the recommendations of the manufacturer without appreciable stretching, tearing, or other damage. The material shall permit cutting and application at temperatures of 40 to 100°F (4 to 38°C).

715.9.2.6.1.2-Approval Process: The WVDOH approval process for Black Opaque Overlay Film is specified within Section 715.9.2.9.

715.9.2.6.2- Transparent Overlay Films: A colored, transparent, typically acrylic, transparent pressure-sensitive film designed for permanent graphics that may be prespaced and electronically cut. These films have a synthetic liner that resists moisture absorption and static buildup.

715.9.2.6.2.1- Transparent Overlay Film Requirements:

715.9.2.6.2.1.1- Adhesive: This material shall utilize a transparent pressure sensitive adhesive.

715.9.2.6.2.1.2- Chemical Resistance: This material shall resist mild alkalis, mild acids, and salt. The material shall exhibit excellent resistance to water, with exception to cases of submersion.

715.9.2.6.2.1.3- Color Standards: Transparent overlay films applied to the manufacturer's approved white sheeting shall produce colors meeting the daytime and nighttime color requirements of ASTM D4956 for like colored sheeting. Testing shall be conducted in accordance with ASTM D4956.

715.9.2.6.2.1.4- Transparency: After application over the manufacturer's white sheeting, the film's level of transparency shall result in a minimum retroreflectivity level of seventy (70) % of the minimum required retroreflectivity level, as specified

herein, of the like colored sheeting of the same grade as the white sheeting. Testing shall be conducted in accordance with ASTM D4956.

715.9.2.6.2.1.5- Durability: Durability requirements of transparent overlay films, depending on the Type sheeting the material is to be utilized with and the intended application, are specified in Sections 715.9.2.1 through 715.9.2.4.

715.9.2.6.2.1.6 – Shelf Life: A minimum shelf life shall not be required for the film to be approved for use with the manufacturer's sheeting products. However, in order for the film to be approved for manufacturing purposes within the Division's CSS, a minimum (1) year shelf life shall be required. Reasonable conditional requirements pertaining to storage, such as temperature and relative humidity, shall be permitted.

715.9.2.6.2.1.7- CSS Requirements: In addition to, but not limited to, any other requirements stated herein, all transparent overlay film to be approved for manufacturing purposes within the CSS shall be an acrylic material and shall be supplied on a clear liner. In addition, this material shall have sufficient strength so that it can be handled, processed, and applied according to the recommendations of the manufacturer without appreciable stretching, tearing, or other damage. The material shall permit cutting and application at temperatures of 40 to 100°F (4 to 38°C).

715.9.2.6.2.2-Approval Process: The WVD0H approval process for Transparent Overlay Film is specified within Section 715.9.2.9.

715.9.2.6.3- Opaque and Transparent Inks: Weather resistant, quick drying inks designed for use in traffic sign screen printing processes.

715.9.2.6.3.1- Opaque and Transparent Ink Requirements:

715.9.2.6.3.1.1- Chemical Resistance: This material shall resist mild alkalis, mild acids, and salt. The material shall exhibit excellent resistance to water, with exception to cases of submersion.

715.9.2.6.3.1.2- Color Standards: Transparent inks applied to the manufacturer's approved white sheeting shall produce colors meeting the daytime and nighttime color requirements of ASTM D4956 for like colored sheeting. Testing shall be conducted in accordance with ASTM D4956.

715.9.2.6.3.1.3- Transparency: After application over the manufacturer's white sheeting, the level of transparency of the transparent ink shall result in a minimum retroreflectivity level of seventy (70) % of the minimum required retroreflectivity level, as specified herein, of the like colored sheeting of the same grade as the white sheeting. Testing shall be conducted in accordance with ASTM D4956.

715.9.2.6.3.1.4- Durability: Durability requirements of opaque & transparent inks, depending on the Type sheeting the material is to be utilized with and the intended application, are specified in Sections 715.9.2.1 through 715.9.2.4.

715.9.2.6.3.1.5– Shelf Life: A minimum shelf life shall not be required for the ink to be approved for use with the manufacturer’s sheeting products. However, in order for the ink to be approved for manufacturing purposes within the Division’s CSS, a minimum (1) year shelf life shall be required. Reasonable conditional requirements pertaining to storage, such as temperature and relative humidity, shall be permitted.

715.9.2.6.3.2-Approval Process: The WVD0H approval process for Opaque and Transparent Ink is specified within Section 715.9.2.9.

715.9.2.7 – Durability Requirements: The durability requirements of the various type sheeting materials described herein and their matched components are specified in this Section. The sheeting manufacturer’s obligations in the event that the manufacturer’s material(s) fails to meet the durability requirements specified herein, as applicable, are specified within Section 715.9.2.8.

715.9.2.7.1-Non Work Zone Applications:

715.9.2.7.1.1-Type ASTM-I Sheeting: Finished signs manufactured using Type ASTM-I sheeting shall exhibit the minimum level of performance described herein for a period of seven (7) years after field installation.

The retroreflectivity levels maintained by the sheeting placed on the signs shall be a minimum of fifty (50) % of the required values for new sheeting of the same color, per 715.9.2.1.1.1. For transparent ink and film covered areas over white sheeting, the retroreflectivity levels maintained by these areas of the signs shall be a minimum of thirty-five (35) % [seventy (70) % of the fifty (50) % value specified above] of the required values for new sheeting of the same color as the ink or film, per 715.9.2.1.1.1.

The colors and luminance factors of all areas of finished signs shall be such that the sign remains effective for its intended purpose when viewed from a moving vehicle under normal day and night driving conditions by drivers with normal vision.

All retroreflectivity testing shall be done in accordance with ASTM D4956. All retroreflectivity testing shall be done at the set observation angle / entrance angle geometry of 0.2/-4.

715.9.2.7.1.2-Type ASTM-IV Sheeting: Finished signs manufactured using Type ASTM-IV sheeting shall exhibit the minimum level of performance described herein for a period of ten (10) years after field installation.

The retroreflectivity levels maintained by the sheeting placed on the signs shall be a minimum of eighty (80) % of the required values for new sheeting of the same color, per 715.9.2.2.1.1. For transparent ink and transparent film covered areas over white sheeting, the retroreflectivity levels maintained by these areas of the signs shall be a minimum of fifty-six (56) % [seventy (70) % of the eighty (80) % value specified above] of the required values for new sheeting of the same color as the ink or film, per 715.9.2.2.1.1.

The colors and luminance factors of all areas of finished signs shall be such that the sign remains effective for its intended purpose when viewed from a moving vehicle under normal day and night driving conditions by drivers with normal vision.

All retroreflectivity testing shall be done in accordance with ASTM D4956. All retroreflectivity testing shall be done at the set observation angle / entrance angle geometry of 0.2/-4.

715.9.2.7.1.3-Type ASTM-XI Sheeting:

715.9.2.7.1.3.1-Non Fluorescent Materials: Finished signs manufactured using Type ASTM-XI non-fluorescent sheeting shall exhibit the minimum level of performance described herein for a period of twelve (12) years after field installation.

The retroreflectivity levels maintained by the sheeting placed on the signs shall be a minimum of eighty (80) % of the required values for new sheeting of the same color, per 715.9.2.4.1.1. For transparent ink and film covered areas over white sheeting, the retroreflectivity levels maintained by these areas of the signs shall be a minimum of fifty-six (56) % [seventy (70) % of the eighty (80) % value specified above] of the required values for new sheeting of the same color as the ink or film, per 715.9.2.4.1.1.

The colors and luminance factors of all areas of finished signs shall be such that the sign remains effective for its intended purpose when viewed from a moving vehicle under normal day and night driving conditions by drivers with normal vision.

All retroreflectivity testing shall be done in accordance with ASTM D4956. All retroreflectivity testing shall be done at the set observation angle / entrance angle geometry of 0.2/-4.

715.9.2.7.1.3.2-Fluorescent Materials: Finished signs manufactured using Type ASTM-XI fluorescent sheeting shall exhibit the minimum level of performance described herein for a period of ten (10) years after installation.

The retroreflectivity levels maintained by the sheeting placed on the signs shall be a minimum of eighty (80) % of the required values for new sheeting of the same color, per 715.9.2.4.1.1.

The colors of all areas of finished signs shall be such that the sign remains effective for its intended purpose when viewed from a moving vehicle under normal day and night driving conditions by drivers with normal vision.

The daytime luminance factor of all areas of finished signs shall be in conformance with the daytime luminance factor requirements referenced in Section 715.9.2.4.1.3.

All testing shall be done in accordance with ASTM D4956. All retroreflectivity testing shall be done at the set observation angle / entrance angle geometry of 0.2/-4.

715.9.2.7.2-Work Zone Applications:

715.9.2.7.2.1-Type ASTM-IV Sheeting:

715.9.2.7.2.1.1-Channelization & Delineation Devices: Products in this category include but may not be limited to plastic posts, tubes, barricades, drums, cones, and channelizer cones, including "permanently" installed plastic posts and tubes.

Applicable colors are orange, white, yellow, blue, and red. The sheeting placed on finished products of this type shall have its' performance warranted for a period of three (3) years after application on the finished product.

The Minimum Coefficient of Retroreflection shall be fifty (50) % of the values specified in Section 715.9.2.2.1.1 for sheeting of the same color.

The colors and luminance factors of the applied sheeting shall be such that the sheeting remains effective for its intended purpose when viewed from a moving vehicle under normal day and night driving conditions by drivers with normal vision.

All retroreflectivity testing shall be done in accordance with ASTM D4956. All retroreflectivity testing shall be done at the set observation angle / entrance angle geometry of 0.2/-4.

715.9.2.7.2.2-Type ASTM-VI Sheeting:

715.9.2.7.2.2.1-Roll-Up Signs: Finished roll-up signs manufactured using Type ASTM-VI sheeting shall have their performance warranted for a period of three (3) years after manufacturing.

The retroreflectivity levels maintained by the white or fluorescent-orange areas of the finished signs shall be a minimum of fifty (50) % of the required values for new sheeting of the same color, per Table 715.9.2.3.1.1-I. For transparent ink covered areas over white sheeting, the retroreflectivity levels maintained by these areas of the signs shall be a minimum of fifty (50) % of the required values for like colored screen printed areas over new sheeting (50% of the values in Table 715.9.2.3.1.1-II).

The colors and luminance factors of all areas of finished signs shall be such that the sign remains effective for its intended purpose when viewed from a moving vehicle under normal day and night driving conditions by drivers with normal vision.

The daytime luminance factor of fluorescent-orange finished signs shall be in conformance with the daytime luminance factor requirements referenced in Section 715.9.2.3.1.3.

All testing shall be done in accordance with ASTM D4956. All retroreflectivity testing shall be done at the set observation angle / entrance angle geometry of 0.2/-4.

715.9.2.7.2.3-Type ASTM-XI Sheeting:

715.9.2.7.2.3.1-Signs: Finished work zone signs manufactured using fluorescent-orange Type ASTM-XI material shall have their performance warranted for a period of three (3) years after manufacturing.

The retroreflectivity levels maintained by the sheeting placed on the signs shall be a minimum of fifty (50) % of the required values for new fluorescent-orange sheeting, per 715.9.2.4.1.1.

The colors of all areas of finished signs shall be such that the sign remains effective for its intended purpose when viewed from a moving vehicle under normal day and night driving conditions by drivers with normal vision.

The daytime luminance factor of all areas of finished signs shall be in conformance with the daytime luminance factor requirements referenced in Section 715.9.2.4.1.3 for fluorescent-orange.

All testing shall be done in accordance with ASTM D4956. All retroreflectivity testing shall be done at the set observation angle / entrance angle geometry of 0.2/-4.

715.9.2.7.2.3.2--Channelization & Delineation Devices: Products in this category include but may not be limited to plastic posts, tubes, barricades, drums, cones, and channelizer cones, including “permanently” installed plastic posts and tubes. Applicable colors are orange, white, yellow, blue, and red. The sheeting placed on finished products of this type shall have its’ performance warranted for a period of three (3) years after application on the finished product.

The Minimum Coefficient of Retroreflection shall be fifty (50) % of the values specified in Section 715.9.2.4.1.1 for sheeting of the same color.

The colors and luminance factors of the applied sheeting shall be such that the sheeting remains effective for its intended purpose when viewed from a moving vehicle under normal day and night driving conditions by drivers with normal vision.

The daytime luminance factor of fluorescent-yellow sheeting shall be in conformance with the daytime luminance factor requirements referenced in Section 715.9.2.4.1.3.

All testing shall be done in accordance with ASTM D4956. All retroreflectivity testing shall be done at the set observation angle / entrance angle geometry of 0.2/-4.

715.9.2.8- Warranty Claims: The sheeting manufacturer’s obligations in the event that the manufacturer’s material(s) fails to meet the warranty requirements specified herein are specified within this Section. The retroreflective sheeting and/or matched components used to manufacture finished signs, channelization devices, & delineation devices shall be considered to be in non-compliance with these specifications where it can be shown that during the specified warranty period the finished product has deteriorated due to natural causes to the extent that is in non-compliance with the quantitative requirements contained herein related to retroreflectivity or luminance factor, as applicable, or is otherwise determined to be ineffective for its intended purpose when viewed from a moving vehicle under normal day and night driving conditions by drivers with normal vision. Under such circumstances, the sheeting manufacturer’s warranty obligations shall be as outlined as described herein. The retroreflectivity, color, & luminance factor durability requirements of the various type sheeting materials described herein and their matched components, as well as the required warranty periods, are specified within Section 715.9.2.7.

Warranty claims shall be based on failures which occur as a result of design or manufacturing defects in the manufacturer's sheeting and/or matched components and not of outside causes such as improper fabrication, handling, maintenance, or installation; use of non manufacturer recommended inks, thinners, coatings, or overlay films for the sheeting being used; use of application equipment not recommended by the manufacturer; failure of sign substrate; exposure to chemicals, abrasion, or damage from fasteners used to mount the sign; snow burial; collisions, vandalism, or malicious mischief. It shall be the sheeting manufacturer's responsibility to investigate and demonstrate that the recommendations contained in their product bulletins, information folders, and technical memos have not been followed in cases where the manufacturer chooses to contest the warranty claim.

Replacement sheeting shall carry the unexpired warranty of the sheeting it replaces.

715.9.2.8.1-Non Work Zone Applications:

715.9.2.8.1.1-Signs:

715.9.2.8.1.1.1-Non Fluorescent Type ASTM-IV and Type ASTM-XI Sheeting: If the failure occurs within the first seven (7) years from the date of field installation, the sheeting manufacturer shall, at its expense, restore the sign surface to its original effectiveness. The Division will be responsible for no labor, equipment, or material costs in this case.

If the failure occurs after seven (7) years from the date of field installation, but less than ten (10) years from the date of field installation for Type ASTM-IV material or less than twelve (12) years from the date of field installation for Type ASTM-XI material, the manufacturer shall furnish the necessary amount of sheeting to restore the sign surface to its original effectiveness.

715.9.2.8.1.1.2-Fluorescent Type ASTM-XI Sheeting: If the failure occurs within the first seven (7) years from the date of field installation, the sheeting manufacturer shall, at its expense, restore the sign surface to its original effectiveness. The Division will be responsible for no labor, equipment, or material costs in this case.

If the failure occurs after seven (7) years from the date of field installation, but less than ten (10) years from the date of field installation, the manufacturer shall furnish the necessary amount of sheeting to restore the sign surface to its original effectiveness.

715.9.2.8.2-Work Zone Applications:

715.9.2.8.2.1-Signs:

715.9.2.8.2.1.1-Type ASTM-VI and Type ASTM-XI Sheeting: If the failure occurs within one (1) year from the date of manufacturing, the sheeting manufacturer will, at its expense, provide all required sheeting to restore the effected sign(s) to their original effectiveness.

If failure occurs after one (1) year from the date of manufacturing, but less than two (2) years from the date of manufacturing, the sheeting manufacturer will, at its

expense, provide two-thirds (2/3) of the required sheeting to restore the effected sign(s) to their original effectiveness.

If failure occurs after two (2) years from the date of manufacturing, but less than three (3) years from the date of manufacturing, the sheeting manufacturer will, at its expense, provide one-third (1/3) of the required sheeting to restore the effected sign(s) to their original effectiveness.

715.9.2.8.2.2-Channelization & Delineation Devices:

715.9.2.8.2.2.1-Type ASTM-IV and Type ASTM-XI Sheeting: If the failure occurs within one (1) year from the date of manufacturing, the sheeting manufacturer will, at its expense, provide all required sheeting to restore the effected device(s) to their original effectiveness.

If failure occurs after one (1) year from the date of manufacturing, but less than two (2) years from the date of manufacturing, the sheeting manufacturer will, at its expense, provide two-thirds (2/3) of the required sheeting to restore the effected device(s) to their original effectiveness.

If failure occurs after two (2) years from the date of manufacturing, but less than three (3) years from the date of manufacturing, the sheeting manufacturer will, at its expense, provide one-third (1/3) of the required sheeting to restore the effected device(s) to their original effectiveness.

715.9.2.9-Approval Processes: The WVDOH processes for review and approval of the various material types described in Sections 715.9.2.1 through 715.9.2.6 are described within this Section.

Retroreflective sheeting materials of the Types described herein, manufacturer recommended matched components for use with the sheeting materials, and transfer films to be considered for inclusion on the WVDOH APL shall be submitted to the Materials Division following the current procedures specified by the Materials Division. The manufacturer may contact the Traffic Engineering Division for verification. The manufacturer should include all relevant documentation and information with their submittal, including but not limited to Product Data Sheets, Product Flyers, Manufacturer Product Specifications, Product Bulletins, and any required independent test results described herein.

In addition to the above described documentation and information, the manufacturer shall submit a letter of certification prior to approval. This letter shall include the following:

1. Certification that the material(s) submitted for approval will meet all applicable requirements contained within Section 715 of the WVDOH Standard Specifications. The applicable material Type designation, as defined in this specification, should also

be referenced. If the material is a Type ASTM-I, IV, or XI material and not intended solely for application to work zone devices as defined herein, or is a fluorescent-orange material intended for application to rigid substrate signs, and does not meet the requirements of this specification to be considered rotationally insensitive, the manufacturer should note this exception in the certification letter. Classification of the material as being rotationally sensitive will not prevent approval of the material.

2. Certification that the manufacturer agrees to warranty the performance of the material(s) in accordance with Section 715 of the WVDOH Standard Specifications.
3. Certification that the material(s) have a minimum one (1) year shelf life, when stored as recommended by the manufacturer, if the manufacturer is seeking approval of the material(s) for manufacturing purposes within the CSS.

All submitted information will be forwarded to the WVDOH Traffic Engineering Division, which will in turn contact and work directly with the manufacturer during the evaluation process. The Traffic Engineering Division will evaluate all submitted literature and documentation for compliance with the specified requirements as well as satisfactory independent testing results, as applicable. The Traffic Engineering Division will also arrange for the manufacturer to furnish test samples for evaluation of the materials suitability for use within the CSS, as applicable. After the evaluation is complete, the Traffic Engineering Division will inform the Materials Division in writing of the outcome of its evaluation.

The WVDOH reserves the right to conduct testing, whether internally or through an independent testing agency of its choice, on any material submitted for approval in order to verify that the material meets any of the material specifications herein. This testing may be conducted prior to or any time after approval is issued. Any such testing shall be conducted in accordance with the testing requirements of the applicable standardization body, such as ASTM or AASHTO.

715.9.2.9.1-Retroreflective Sheeting Materials & Matched Components:

715.9.2.9.1.1-Independent Test Results: In order for the material to be evaluated and considered for approval, independent test results must be supplied by the manufacturer demonstrating the sheeting material's conformance with the requirements specified within the applicable Section 715.9.2.1, 715.9.2.2, 715.9.2.3, or 715.9.2.4, with the exception of the requirements specified in the "Shelf Life", "Backing Class", and "Durability" subsections. The independent test results shall include accelerated outdoor weathering test results conducted in conformance with ASTM D4956. Artificial accelerated lab weathering shall not be accepted except for materials intended for work zone applications. Materials intended for work zone applications shall include all Type ASTM-VI materials and shall include, but may not be limited to, other "Type" materials

intended for use on plastic posts, tubes, barricades, drums, cones, and channelizer cones, including “permanently” installed plastic posts and tubes. However, any approval granted based on the results of artificial accelerated lab weathering shall be provisional in nature and noted as such on the APL. As a condition of the acceptance of artificial accelerated lab weathering results in lieu of accelerated outdoor weathering results, the accelerated outdoor weathering process shall be ongoing at the time of issuance of the provisional approval. In addition, the material manufacturer shall submit the standard outdoor weathering test results to the WVDOH within nine (9) months after the effective date of the provisional approval for Type ASTM-VI materials, and within fifteen (15) months after the effective date of the provisional approval for all other material “Types”. AASHTO-NTPEP results shall be considered acceptable for meeting the accelerated outdoor weathering test results requirement.

Rotational sensitivity testing is not required for sheeting materials intended solely for application to work zone devices, as defined herein, with the exception of fluorescent-orange materials intended for application to rigid substrate signs. Otherwise, if a material submitted for approval does not meet the rotational sensitivity requirements herein, rotational sensitivity testing may be omitted from the independent test results provided that the manufacturer notes that the material does not meet the rotational sensitivity requirement in their required certification letter described in Section 715.9.2.9.

715.9.2.9.1.1.1-Accelerated Weathering Test Results: The duration of testing required shall be based on the sheeting material Type, as defined by this specification, and the intended application of the material. All Type ASTM-I sheeting materials shall be subjected to two (2) years of accelerated outdoor weathering. Type ASTM-IV and Type ASTM-XI materials intended for non work zone applications shall be subjected to three (3) years of accelerated outdoor weathering. Type ASTM-IV and Type ASTM-XI materials intended for work zone applications shall be subjected to one (1) year of accelerated outdoor weathering. Type ASTM-VI materials shall be subjected to six (6) months of accelerated outdoor weathering.

After completion of the accelerated outdoor weathering, all materials shall be in conformance with the general durability requirements related to cracking, scaling, pitting, blistering, edge lifting, curling, shrinkage, and expansion specified in ASTM D4956.

The retroreflectivity level of the sheeting material after completion of the accelerated outdoor weathering, when tested in accordance with ASTM D4956, shall be in conformance with the requirements of ASTM D4956. ASTM D4956 specifies the level of retroreflectivity to be maintained by the material as a percentage of the initial required retroreflectivity level specified in ASTM D4956. An exception to this shall apply to Type ASTM-VI materials. In this case, the percentage specified in ASTM

D4956 shall be applied to the applicable initial required retroreflectivity levels specified in Section 715.9.2.3.1.1 rather than the initial values specified in ASTM D4956.

After completion of the accelerated weathering, the sheeting material shall be in conformance with the requirements specified in the "Color" (daytime) and "Luminance Factor" subsections within the applicable Section 715.9.2.1, 715.9.2.2, 715.9.2.3, or 715.9.2.4 when tested in accordance with ASTM D4956.

The manufacturer recommended matched components for use with the sheeting material must also be subjected to accelerated outdoor weathering in order for approval to be given for the manufacturing of signs requiring the use of these matched components. The duration of accelerated outdoor weathering required for the matched components shall be the same as the applicable duration required for the sheeting.

The retroreflectivity level of the areas of all signs processed with transparent inks or transparent films after completion of the accelerated outdoor weathering, when tested in accordance with ASTM D4956, shall be a minimum of seventy (70) % of the retroreflectivity values required for like colored sheeting of the same material Type upon completion of the accelerated outdoor weathering.

After completion of the accelerated outdoor weathering, the areas of all signs processed with transparent inks or transparent films shall be in conformance with the requirements specified in the "Color" (daytime) and "Luminance Factor" subsections within the applicable Section 715.9.2.1, 715.9.2.2, 715.9.2.3, or 715.9.2.4 when tested in accordance with ASTM D4956.

If artificial accelerated lab weathering is conducted in order to obtain provisional approval for a material intended for work zone applications, per Section 715.9.2.9.1.1, the weathering process shall be done in accordance with the ASTM D4956 specifications. The performance requirements for the results of the testing shall be the same as described herein for accelerated outdoor weathering.

715.9.2.9.1.2—CSS Evaluation: Material Types and their matched components that are typically used in manufacturing processes within the CSS are subject to evaluation by WVDOH personnel for their suitability for use within the Division's CSS. This evaluation is primarily focused on the compatibility, workability, and general "user friendliness" of the materials when used for production purposes within the CSS using the equipment in place at the CSS, as well as the characteristics of the materials in these regards relative to other materials which have already been approved. The suitability of the materials in these regards shall be based solely on the judgment of the Division. The un-acceptance of the manufacturer's sheeting material and/or matched components based

on this evaluation shall not prevent the listing of these materials on the APL and the use of these materials by private fabricators supplying finished products to the WVDOH or to Contractors performing Contracts for the WVDOH.

In order for a sheeting material to be eligible for bidding on any Division raw material supply Contract, particular Section(s) of the Contract may require that only the sheeting material be determined to be suitable for use within the CSS. Other Section(s) may require that one or more of the matched components also be determined to be suitable for use within the CSS. These requirements shall be indicated in the raw material supply Contract.

In addition to any other requirements specified herein, in order to be accepted for manufacturing purposes within the CSS all sheeting materials shall permit application to aluminum blanks and shall permit processing with compatible matched components at temperatures between 60 to 100°F (16 to 38°C) and relative humidity at 20% to 80 % when performed in accordance with the manufacturer's recommendations. In addition, the sheeting and the matched component inks shall allow oven accelerated curing, providing that the manufacturer's recommendations are followed.

Any restrictions on the use of the material or any of the matched components within the CSS shall be noted on the APL.

In addition to the information provided above, note the following:

1. Type ASTM-I material is not specified for any applications on WVDOH advertised construction projects. The specifications and approval process described herein for Type ASTM-I material are in place solely for the purpose of establishing requirements for the placement of Type ASTM-I materials on the Division's APL. A listing of approved Type ASTM-I materials is maintained in order to establish a list of materials approved for bidding on Division raw material supply Contracts. Therefore, no Type ASTM-I material that is not accepted by the Division for manufacturing purposes within the CSS shall be placed on the APL.
2. Type ASTM-IV sheeting materials and their matched components intended for work zone (as described herein) applications only are not required to be evaluated for use within the CSS.
3. Type ASTM-VI sheeting materials and their matched components are not required to be evaluated for use within the CSS.
4. With the exception of fluorescent-orange material and its' applicable matched components intended for use in manufacturing temporary work zone signs, Type ASTM-XI sheeting materials and their matched components intended for work zone (as described herein) applications only are not required to be evaluated for use within the CSS.

715.9.2.9.2-Transfer Films: The transfer film section of the APL is solely for the purpose of establishing an approved list of transfer tapes for bidding on Division raw material supply Contracts. Private fabricators are not required to utilize transfer tapes listed on the APL. This shall be noted on the APL. Therefore, no transfer film that is not accepted by the Division for manufacturing purposes within the CSS shall be placed on the APL.

All transfer films submitted for approval shall be transparent. No other specific requirements are listed herein. However, transfer films shall be thoroughly evaluated by personnel within the Division's CSS. The CSS evaluation is primarily focused on the compatibility, workability, and general "user friendliness" of the material when used for production purposes within the CSS using the equipment in place at the CSS, as well as the characteristics of the material in these regards relative to other transfer films which have already been approved. The suitability of the material in this regard shall be based solely on the judgment of the Division.

EXHIBIT B

POCKET DIMENSION CHART

SIGN SHAPE	POCKET SIZE
48" Diamond	9x9 (Pocket B)
36" Diamond	7x7 (Pocket A)
60x60 Square	9x9 (Pocket B)
48x48 Square	9x9 (Pocket B)
36x48 vert rectangle	9x9 (Pocket B)
36x60 vert rectangle	9x9 (Pocket B)
24x30 vert rectangle	7x7 (Pocket A)
60x30 horiz rectangle	9x9 (Pocket B)
48x36 horiz rectangle	7x7 (Pocket A)
48x30 horiz rectangle	7x7 (Pocket A)
48x24 horiz rectangle	7x7 (Pocket A)
30x24 horiz rectangle	7x7 (Pocket A)
30x18 horiz rectangle	7x7 (Pocket A)
36" octagon	2x4 rectangular
48" octagon	2-1/2x3-1/4 rectangular
36" triangle	2x4 rectangular
48" triangle	2-1/2x3-1/4 rectangular

EXHIBIT C

36" OCTAGON - CORNER POCKET AND RIB CONFIGURATION

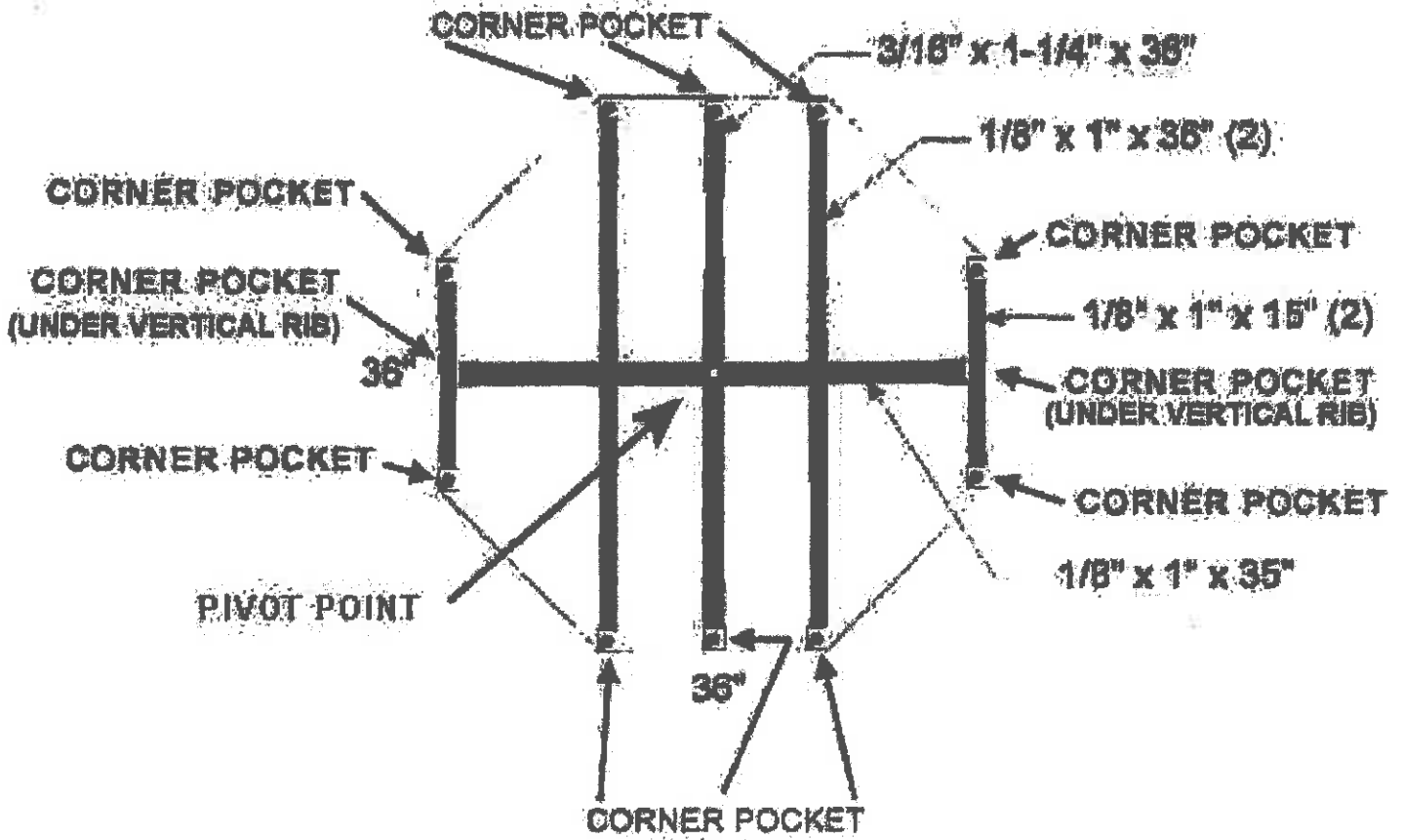

EXHIBIT D

48" OCTAGON - CORNER POCKET AND RIB CONFIGURATION

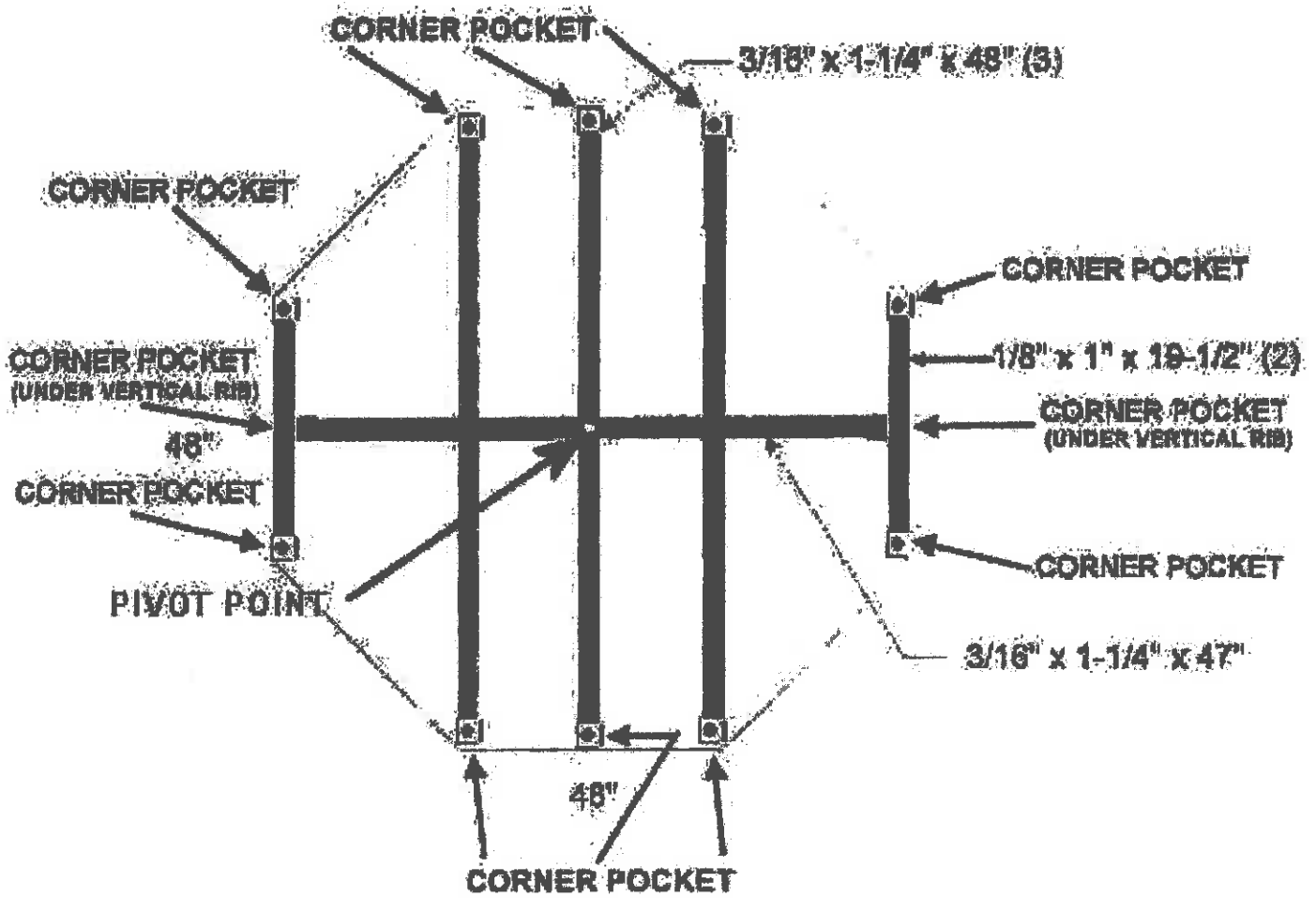

EXHIBIT E

36" DIAMOND - CORNER POCKET AND RIB CONFIGURATION

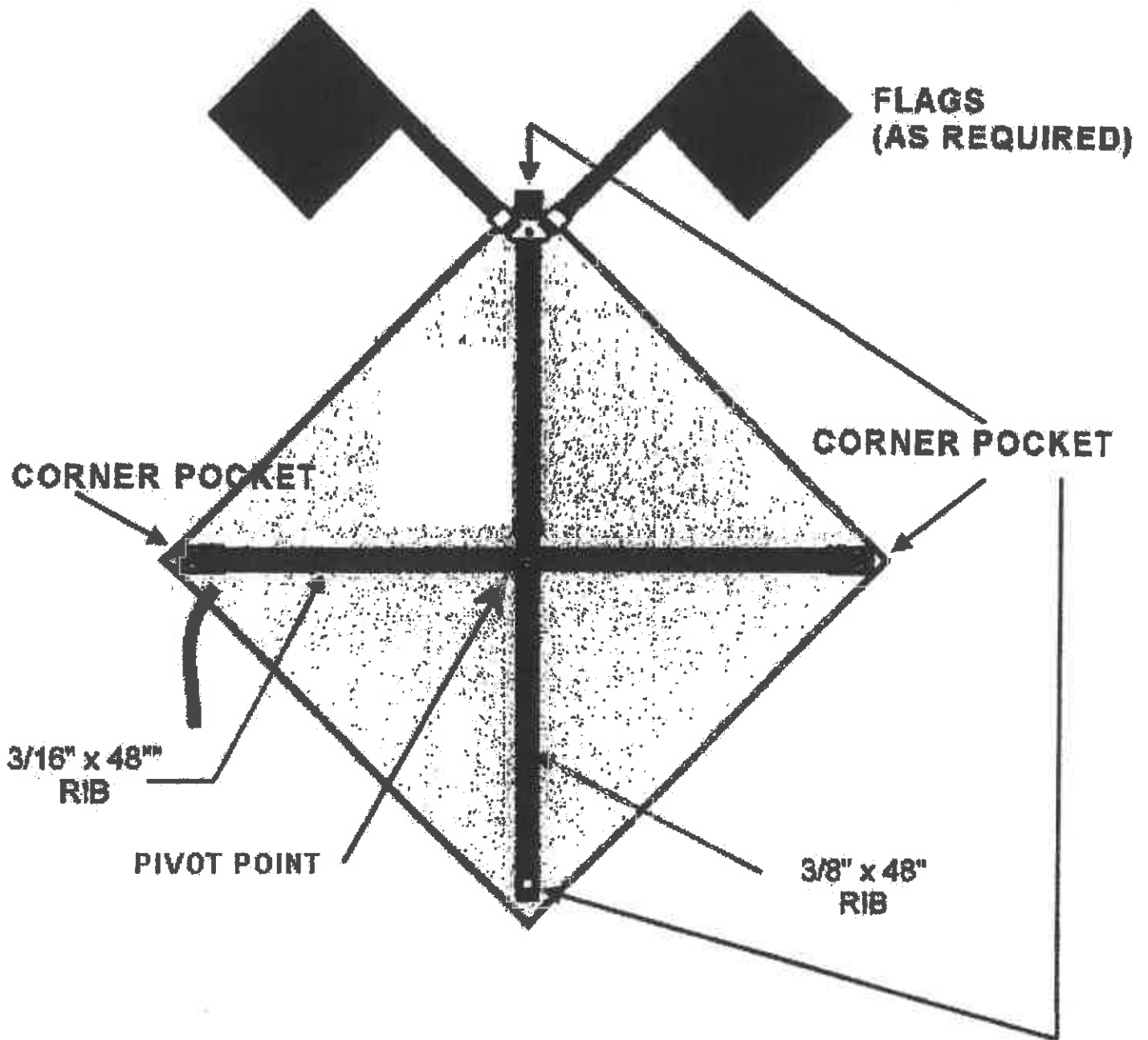

EXHIBIT F

48x48 DIAMOND - CORNER POCKET AND RIB CONFIGURATION

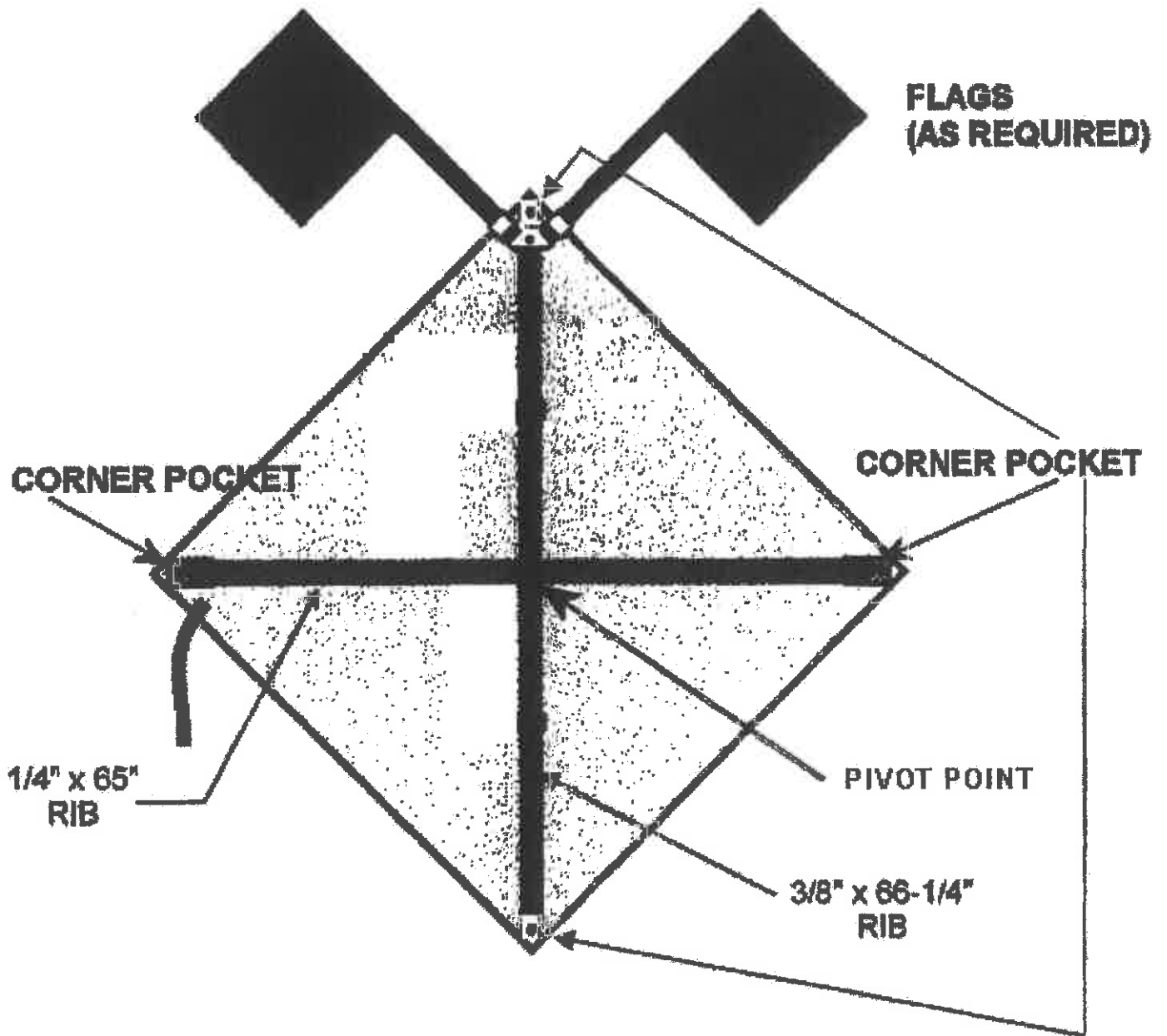

EXHIBIT G

36" TRIANGLE - CORNER POCKET AND RIB CONFIGURATION

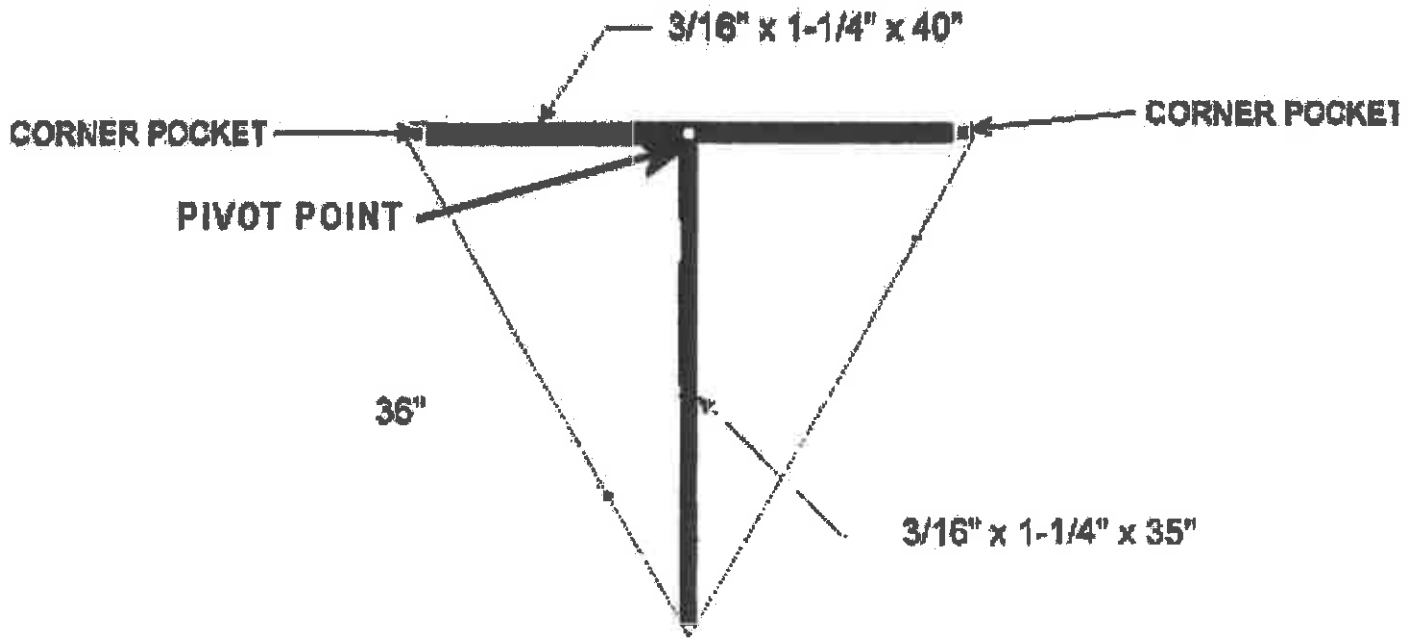

EXHIBIT H

48" TRIANGLE - CORNER POCKET AND RIB CONFIGURATION

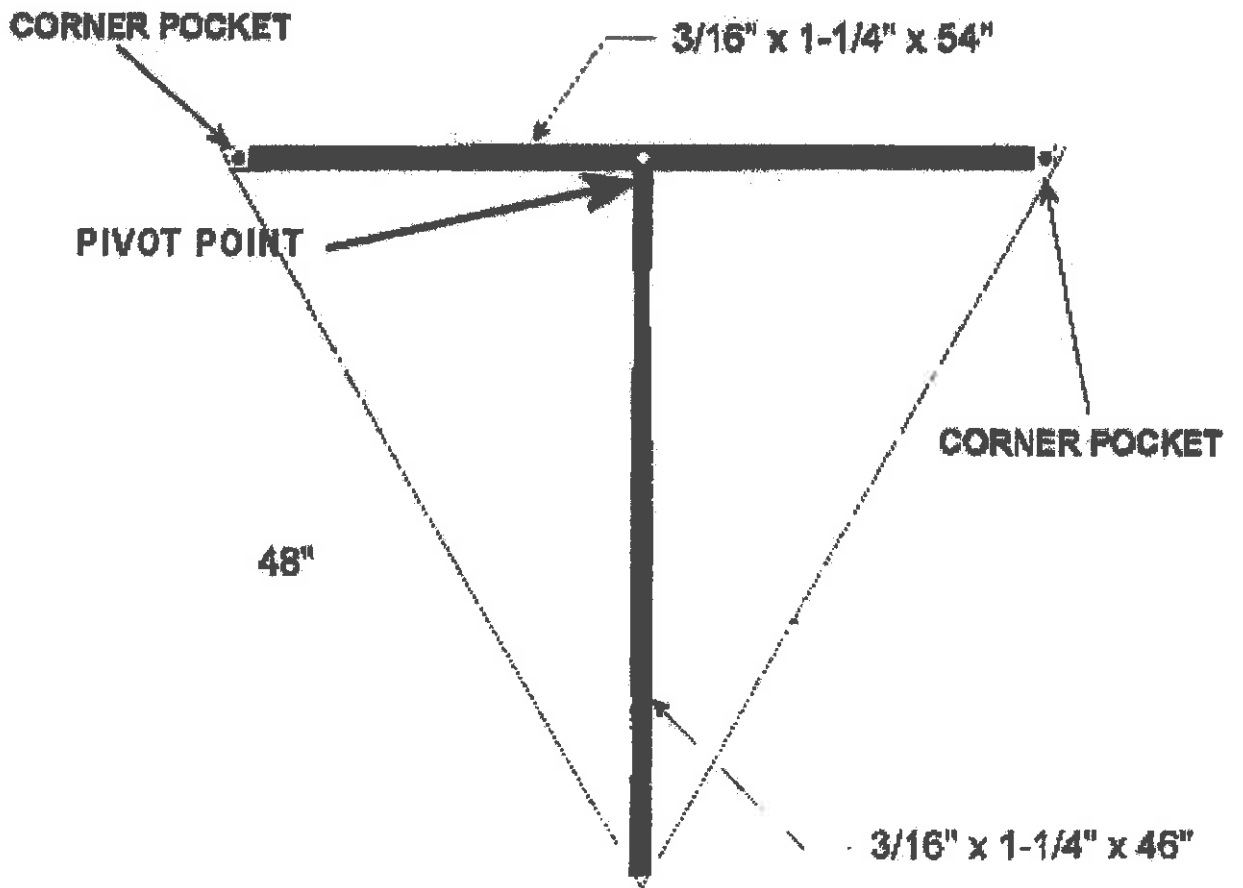
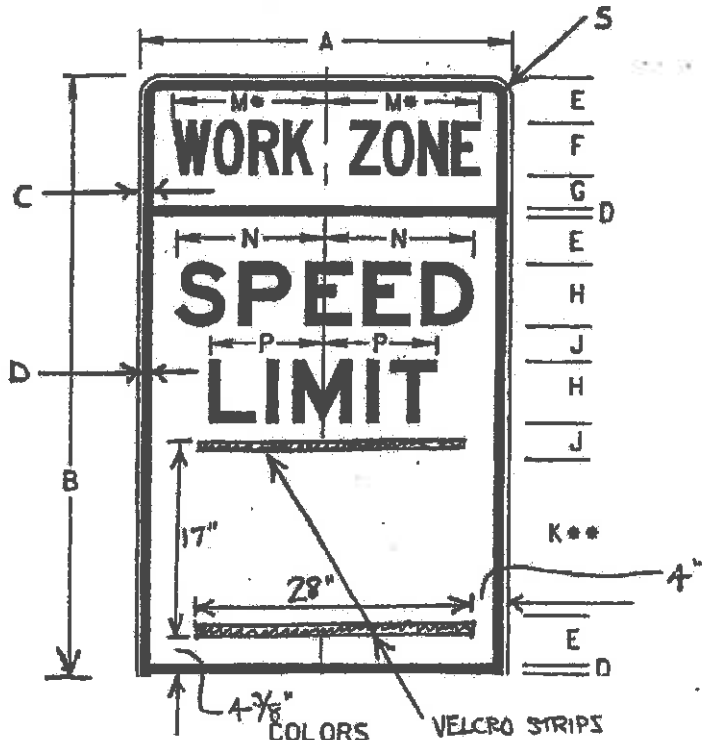

EXHIBIT I
 BID ITEM 11 - MODIFIED STANDARD DETAIL



LEGEND - BLACK (NON-REF)
 TOP BACKGROUND - ORANGE (REF)
 MIDDLE BACKGROUND - WHITE (REF)

DIMENSIONS (INCHES)

A	B	C	D	E	F	G	H	J	K	M	N	P	S
36	60	5/8	3/8	4 1/2	5C	3 3/8	6E	3 1/2	15E	14 7/8	14 5/8	10 5/8	1 5/8

* - REDUCE SPACING 50%

EXHIBIT J

36x60 VERTICAL RECTANGLE -
CORNER POCKET AND RIB CONFIGURATION

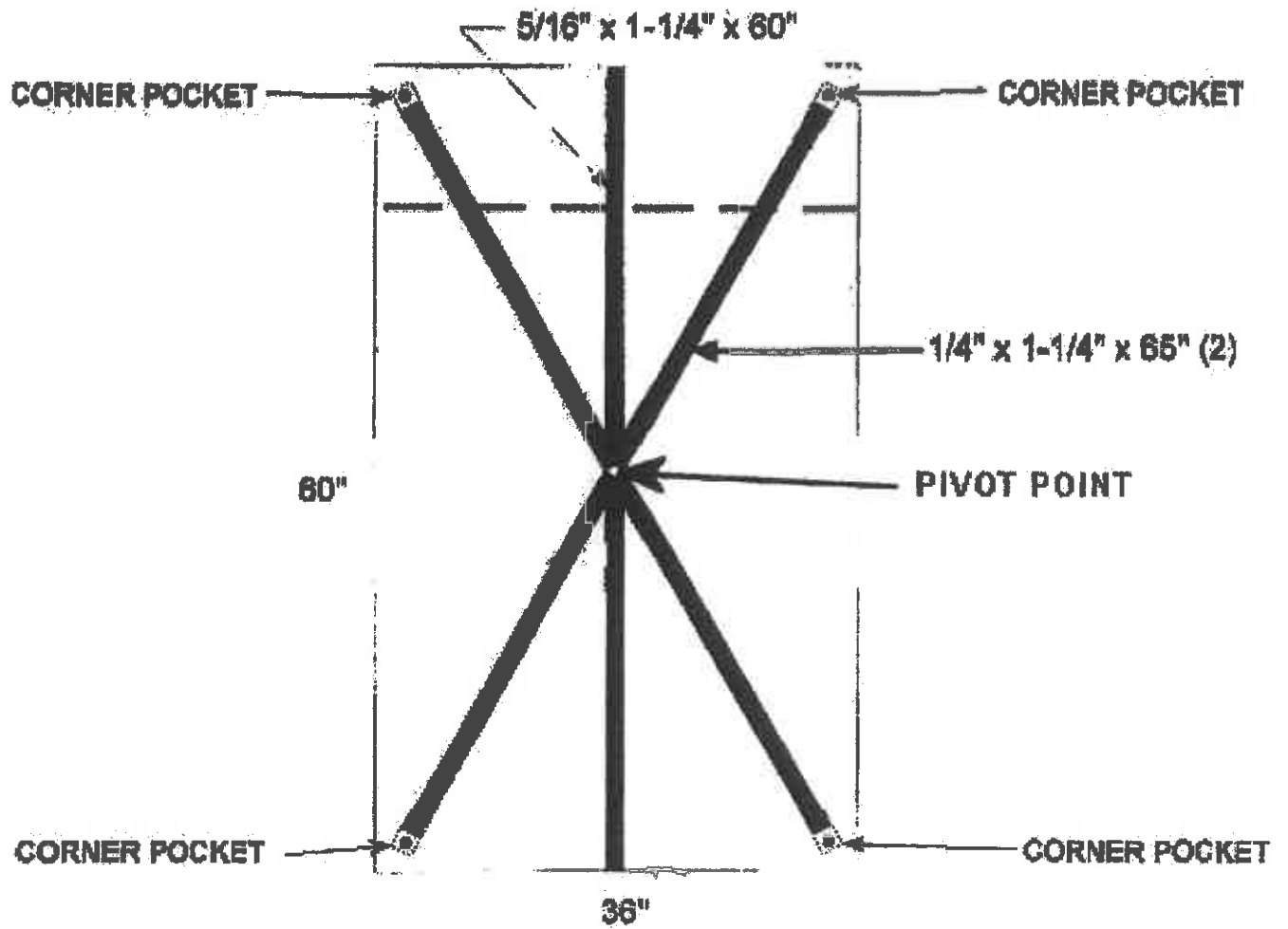
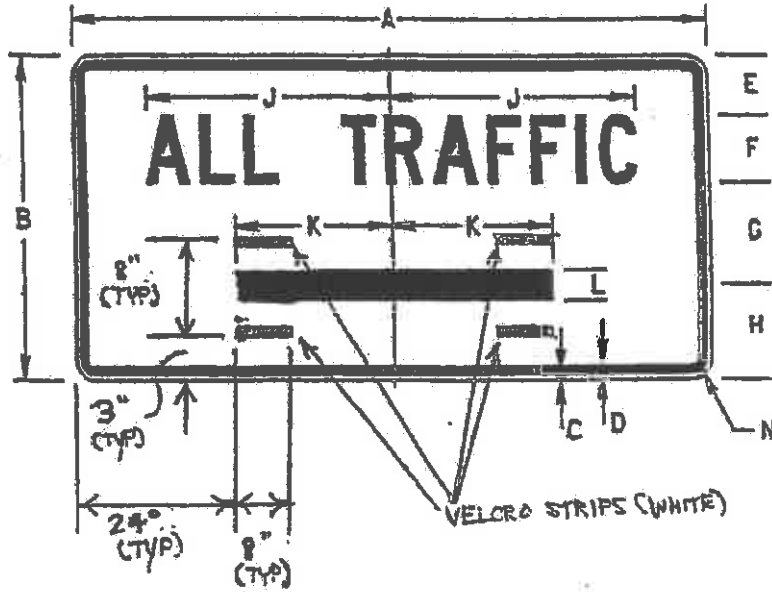

EXHIBIT K
BID ITEM 13 - MODIFIED STANDARD DETAIL



COLOR
LEGEND - BLACK (NON-REF)
BACKGROUND - WHITE (REF)

DIMENSIONS (INCHES)

A	B	C	D	E	F	G	H	J	K	L	M	N
4B	24	3/8	5/8	4 1/2	5C	7 1/2	7	18 1/16	12	2 1/4		1 1/8

ARROW DETAIL

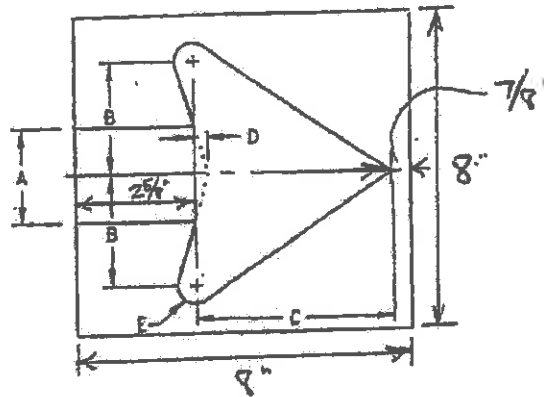

A	B	C	D	E
2 1/4	2 5/8	4 1/2	3/8	1/8

EXHIBIT L

**48X24 HORIZONTAL RECTANGLE -
CORNER POCKET AND RIB CONFIGURATION**

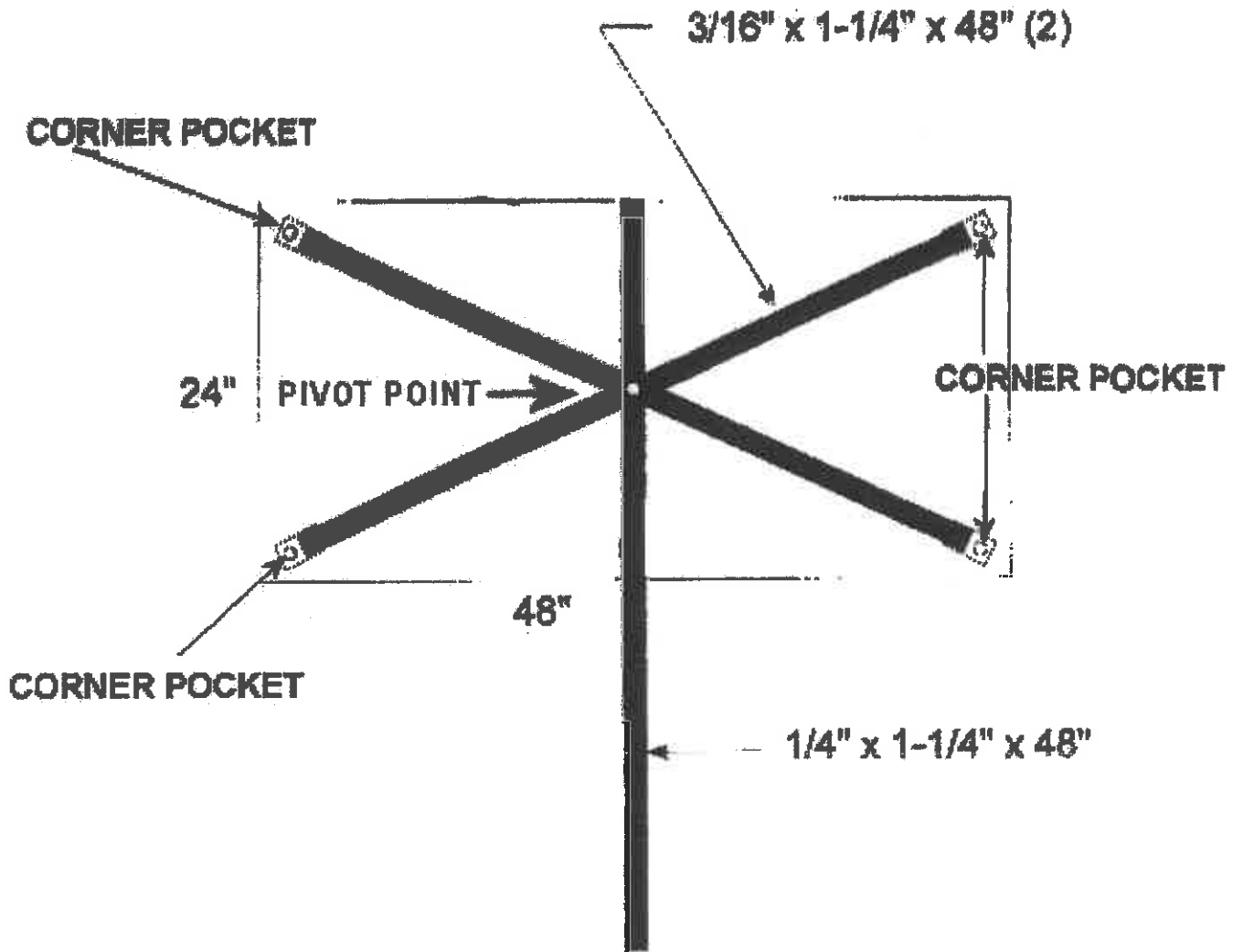

EXHIBIT M

24 X 30 VERTICAL RECTANGLE -
CORNER POCKET AND RIB CONFIGURATION

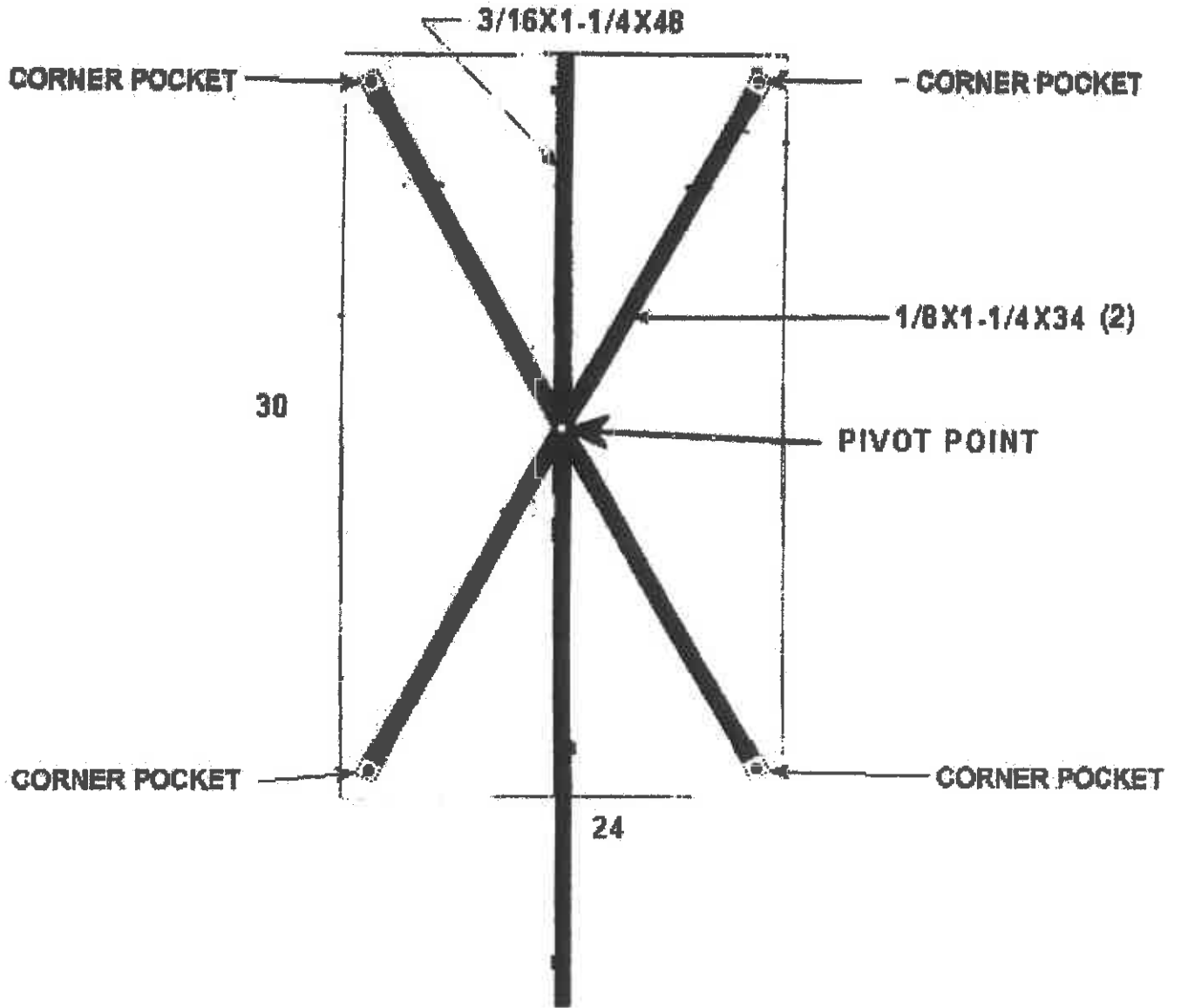

EXHIBIT N

36X48 VERTICAL RECTANGLE -
CORNER POCKET AND RIB CONFIGURATION

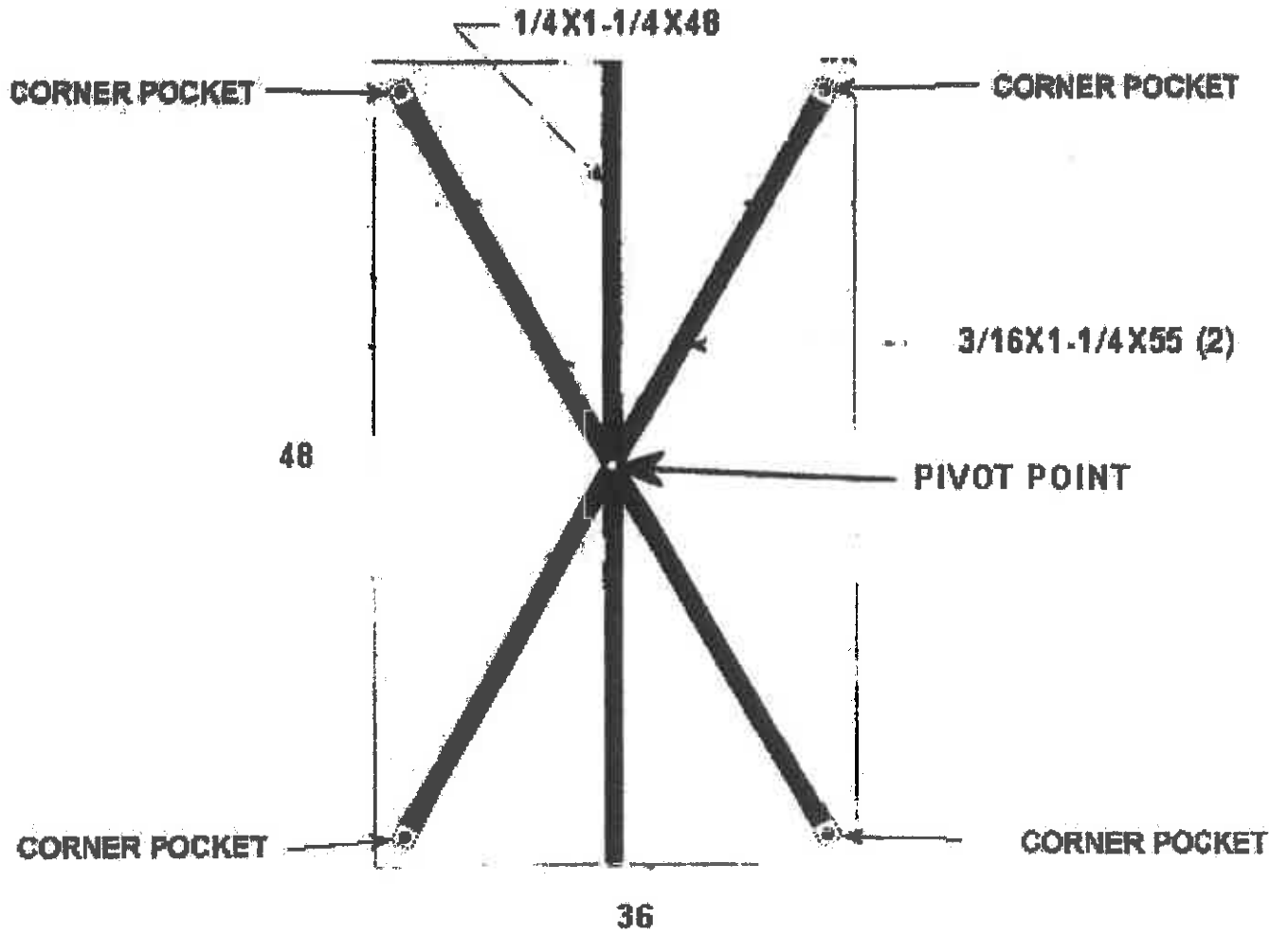

EXHIBIT O

**30X18 HORIZONTAL RECTANGLE -
CORNER POCKET AND RIB CONFIGURATION**

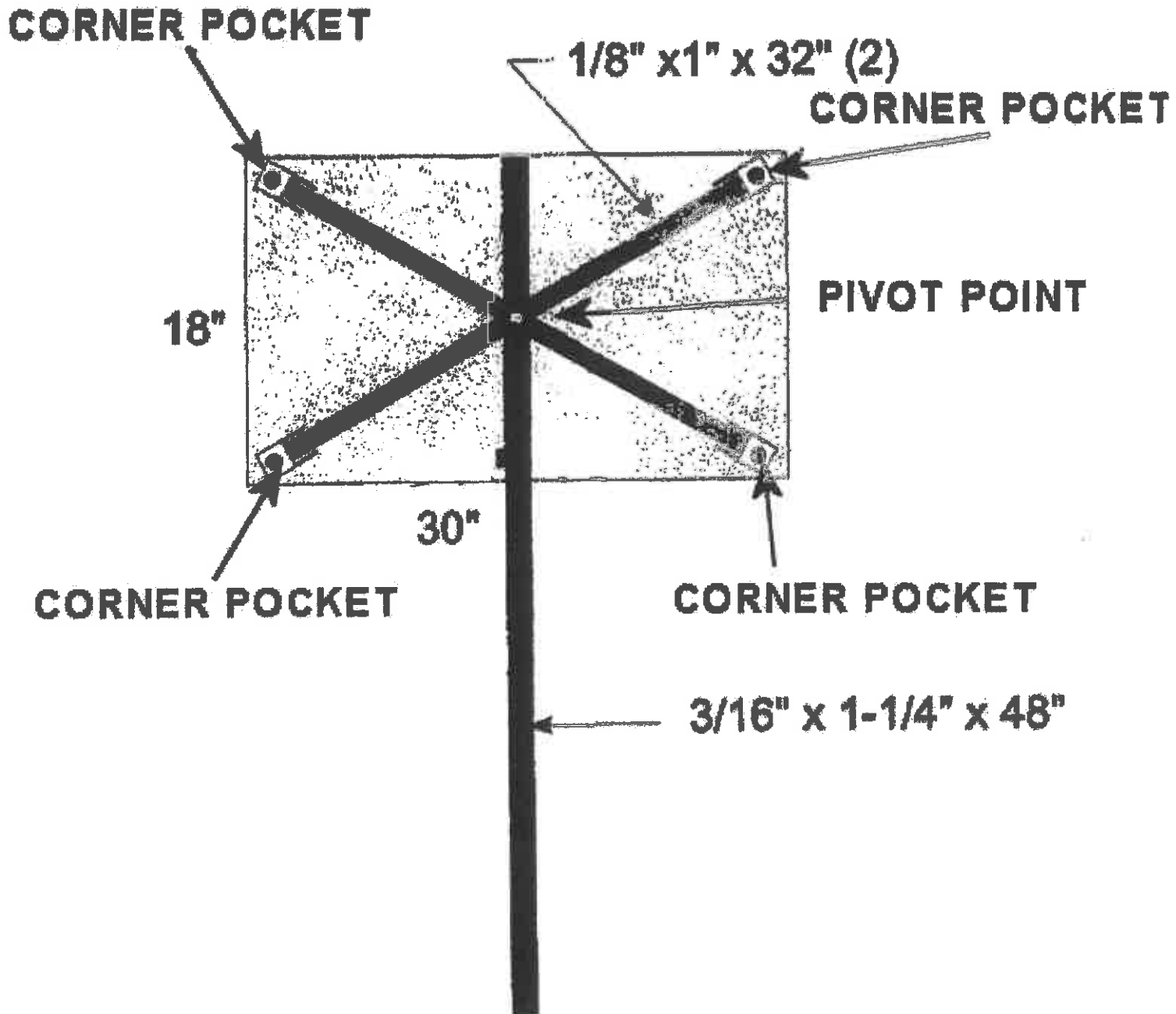
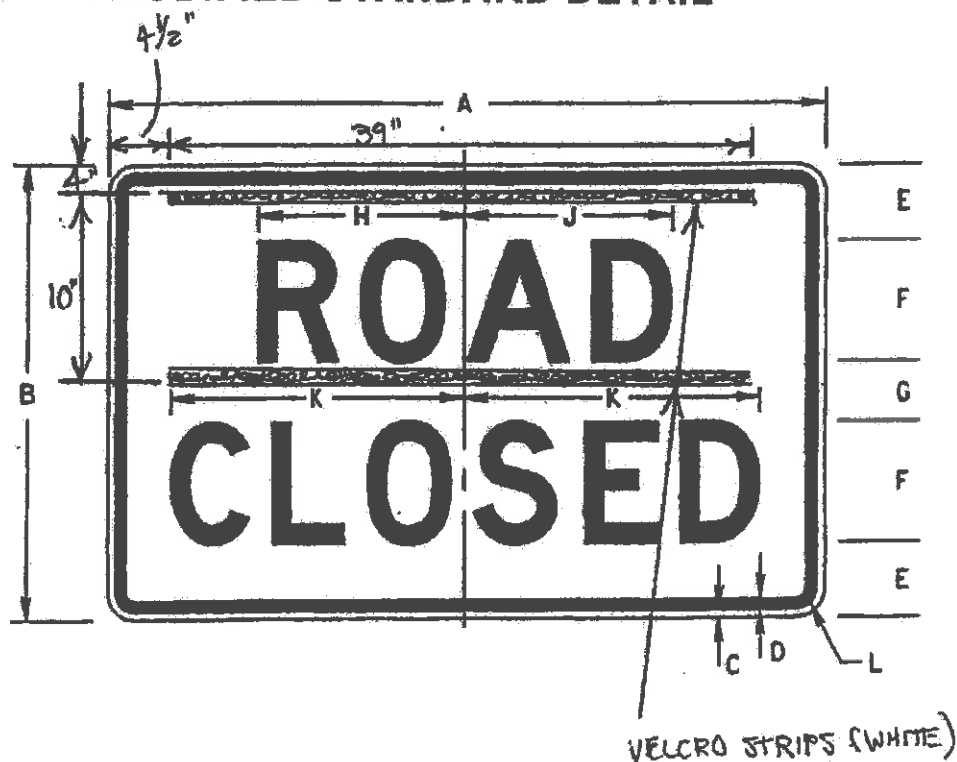

EXHIBIT P
 BID ITEM 17 - MODIFIED STANDARD DETAIL



COLORS
 LEGEND - BLACK (NON-REF)
 BACKGROUND - WHITE (REF)

DIMENSIONS (INCHES)

A	B	C	D	E	F	G	H	J	K	L
48	30	1/2	3/4	5	8D	4	3 1/4	13 1/2	19	1 3/8

EXHIBIT Q

**48x30 HORIZONTAL RECTANGLE -
CORNER POCKET AND RIB CONFIGURATION**

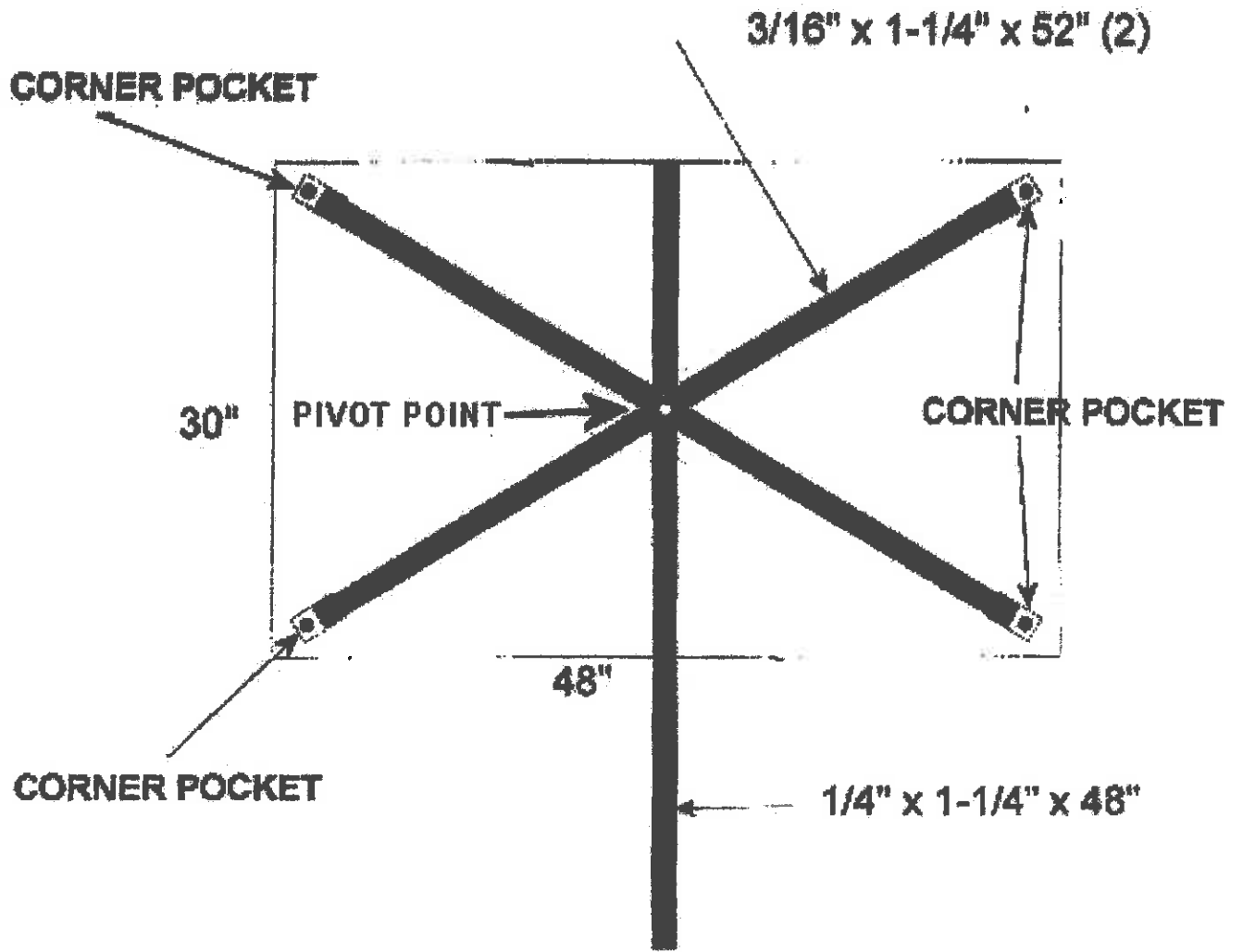
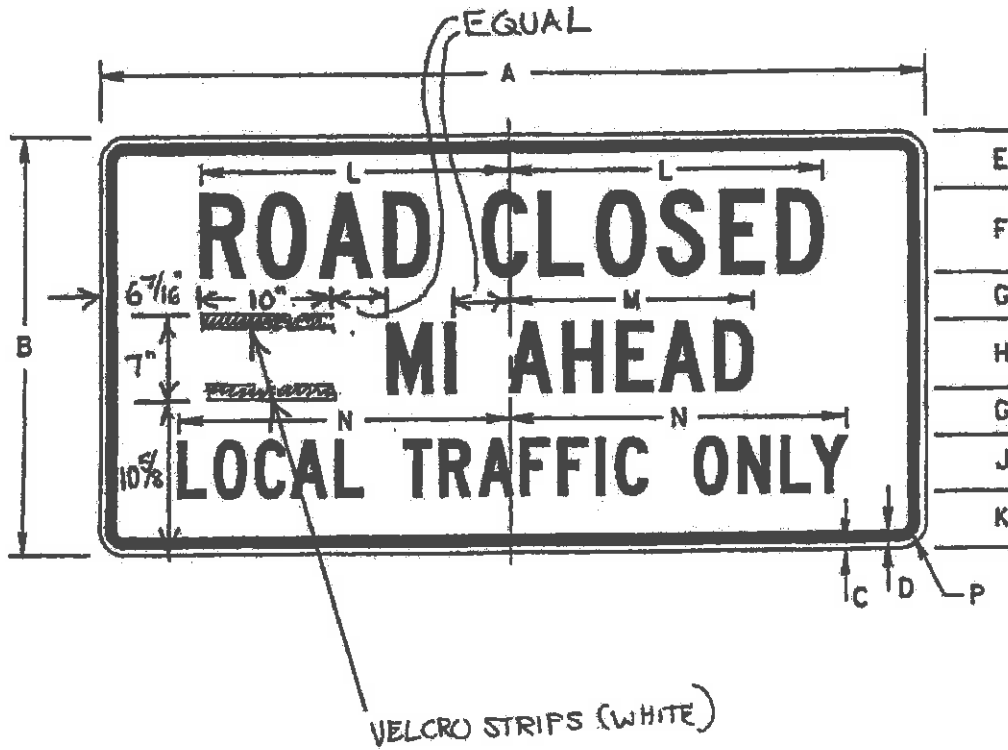

EXHIBIT R

BID ITEM 19 - MODIFIED STANDARD DETAIL



COLORS

LEGEND - BLACK (NON-REF)

BACKGROUND - WHITE (REF)

DIMENSIONS (INCHES)

A	B	C	D	E	F	G	H	J	K	L	M	N	P
60	30	1/2	3/4	4	6C	3 3/8	5C	4C	4 1/4	22 3/16	17 3/16	24 5/16	1 3/8

EXHIBIT S

**60X30 HORIZONTAL RECTANGLE -
CORNER POCKET AND RIB CONFIGURATION**

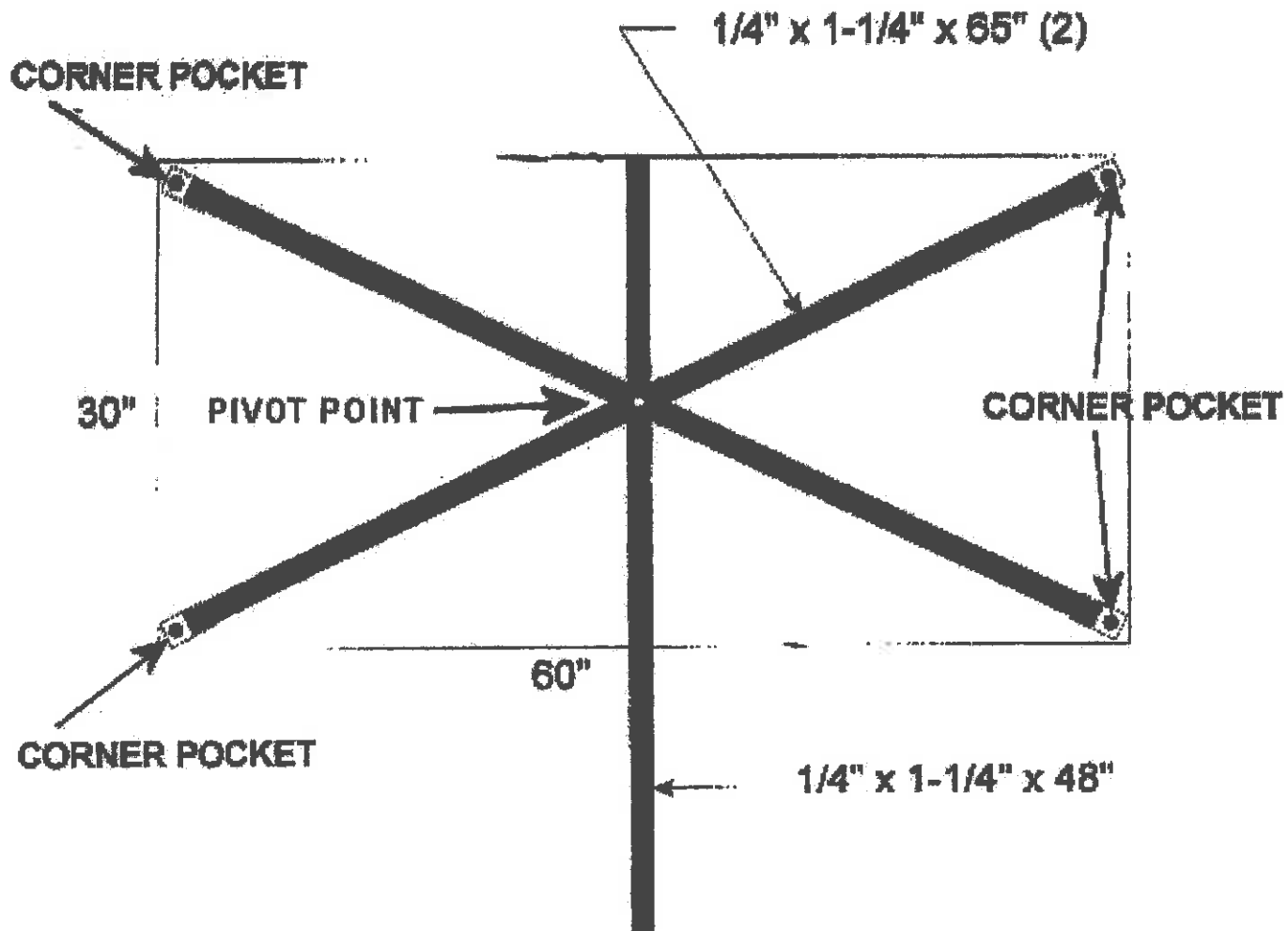
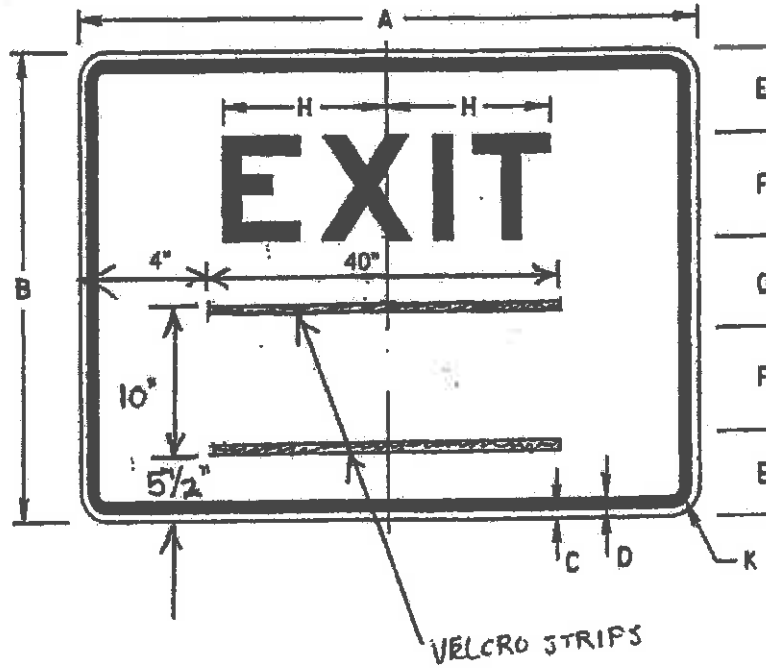

EXHIBIT T

BID ITEM 22 - MODIFIED STANDARD DETAIL



COLORS
 LEGEND - BLACK (NON-REF)
 BACKGROUND - ORANGE (REF)

DIMENSIONS (INCHES)

A	B	C	D	E	F	G	H	I	K
48	36	$\frac{5}{8}$	$\frac{3}{8}$	6 $\frac{1}{2}$	8E	7	12 $\frac{3}{8}$	1	1 $\frac{5}{8}$

EXHIBIT U

**48x36 HORIZONTAL RECTANGLE -
CORNER POCKET AND RIB CONFIGURATION**

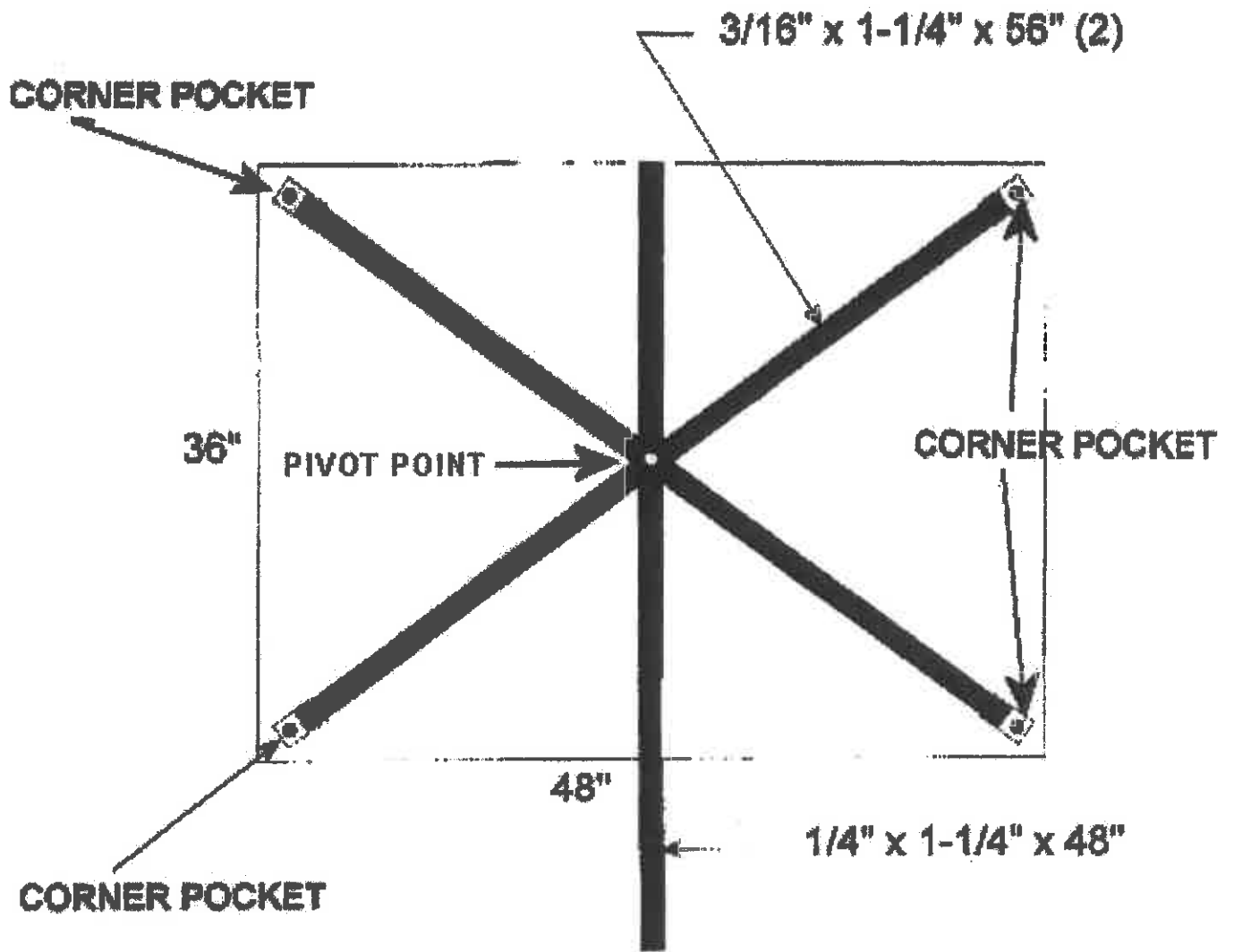

EXHIBIT V

60X60 SQUARE - CORNER POCKET AND RIB CONFIGURATION

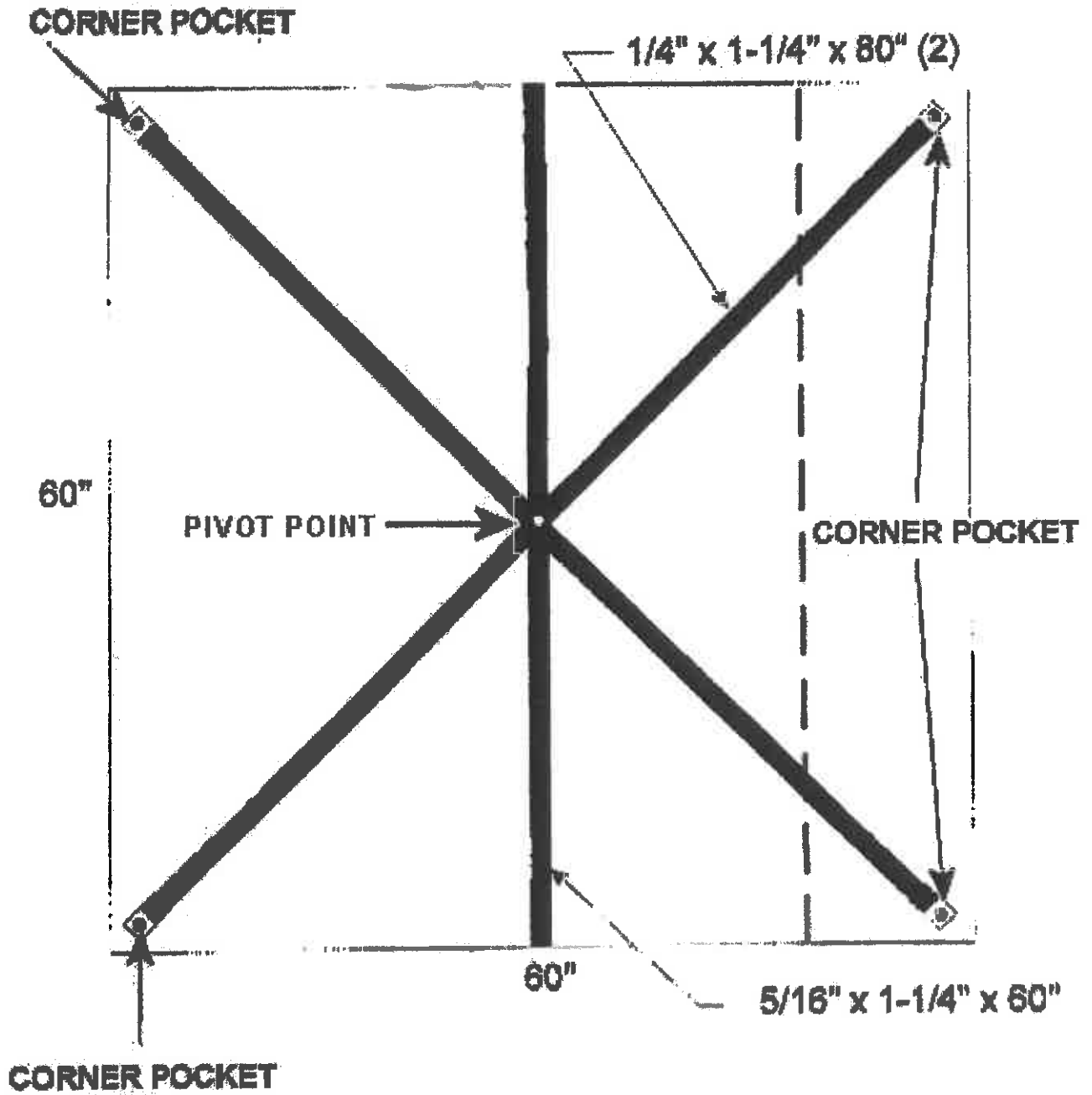
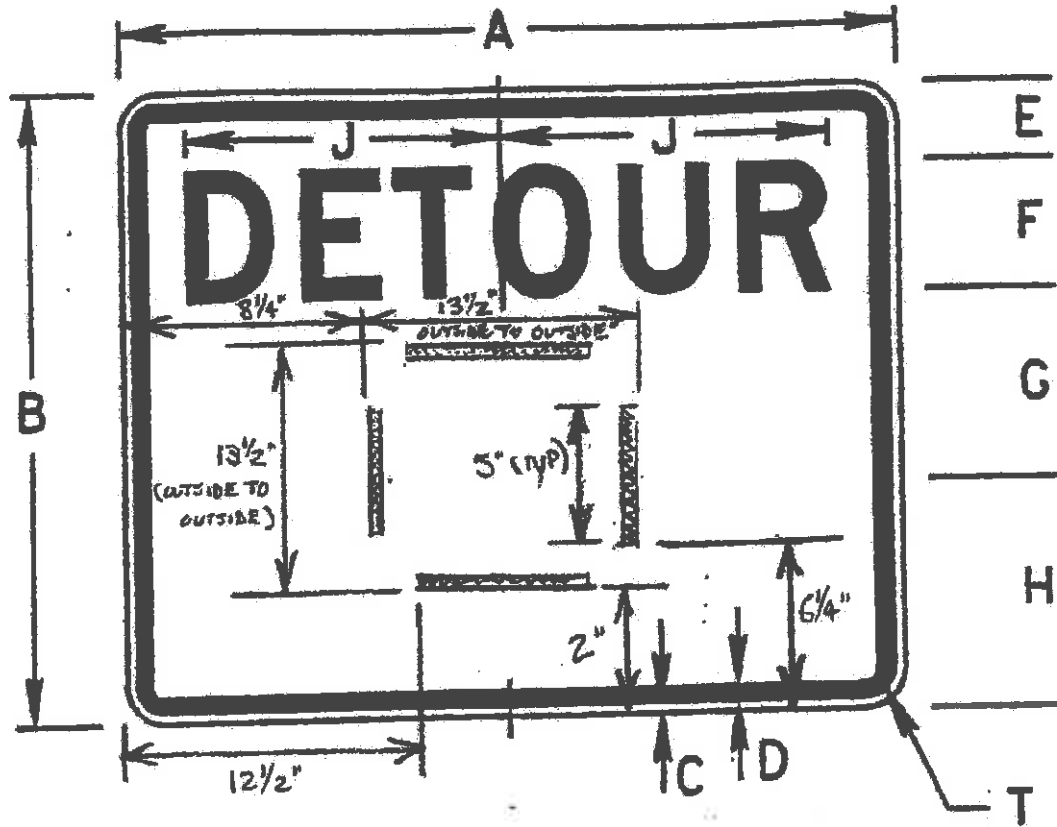

EXHIBIT W

BID ITEM 25 - MODIFIED STANDARD DETAIL.



COLORS
 LEGEND - BLACK (NON-REF)
 BACKGROUND - ORANGE (REF)
 DIMENSIONS (INCHES)

A	B	C	D	E	F	G	H	J	M	N	P	O	R	S	T
30	24	3/8	5/8	3	5D	7 1/4	8 3/4	12 3/16	5	1	12 1/2	2 1/2	3	10	1 1/8

EXHIBIT X
BID ITEM 25 - MODIFIED STANDARD DETAIL (CONTINUED)

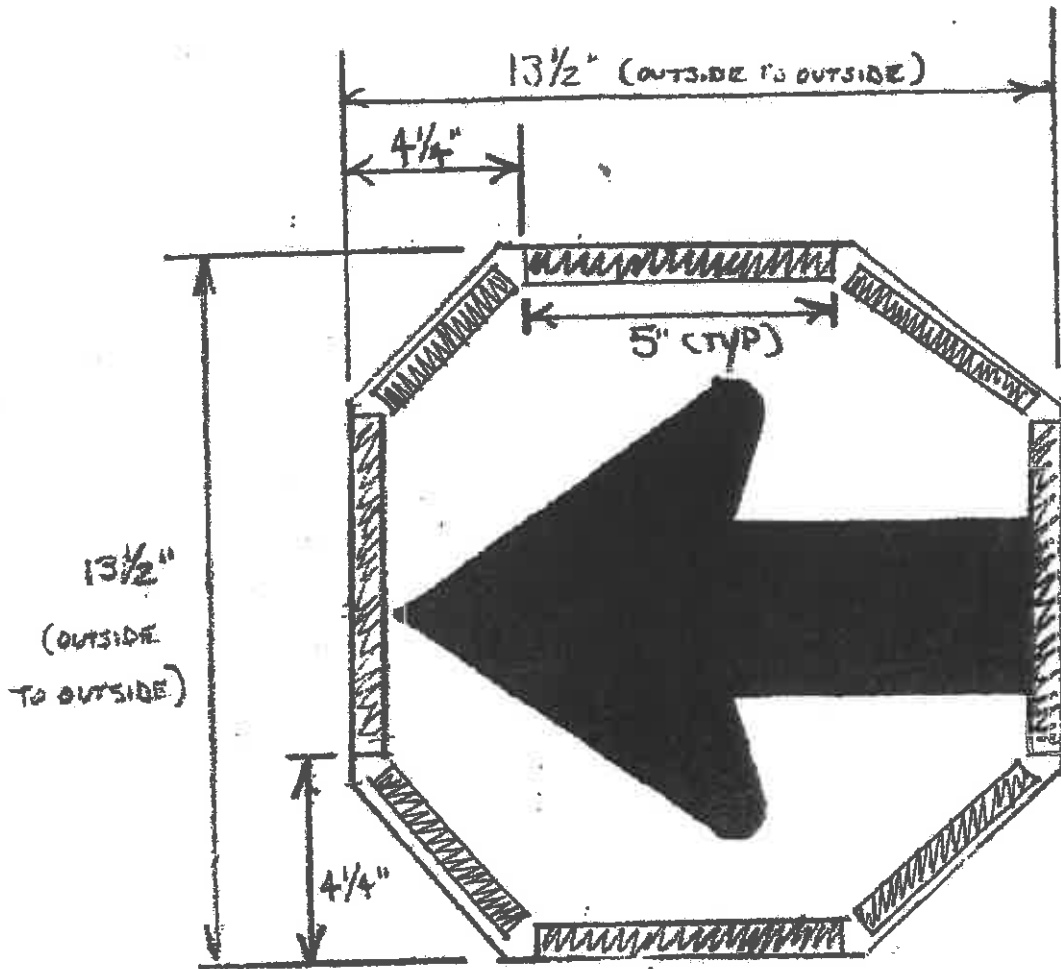

ARROW DETAIL

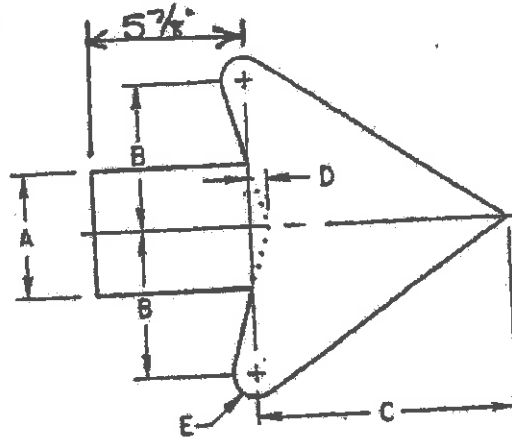

A	B	C	D	E
3/4	3/4	6 5/8	1/2	5/8

EXHIBIT Y

**30X24 HORIZONTAL RECTANGLE -
CORNER POCKET AND RIB CONFIGURATION**

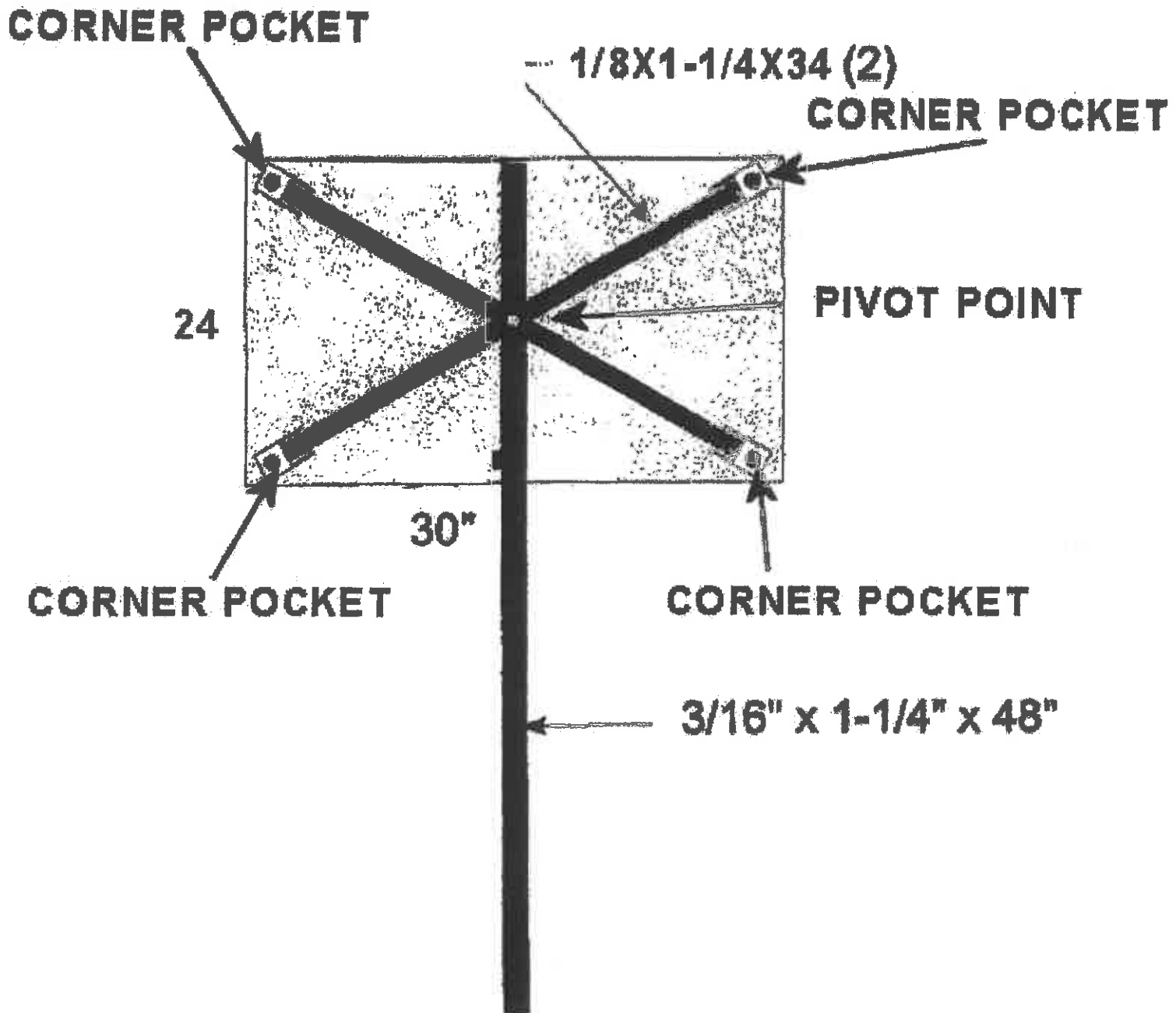

EXHIBIT Z

BID ITEM 26 - MODIFIED STANDARD DETAIL

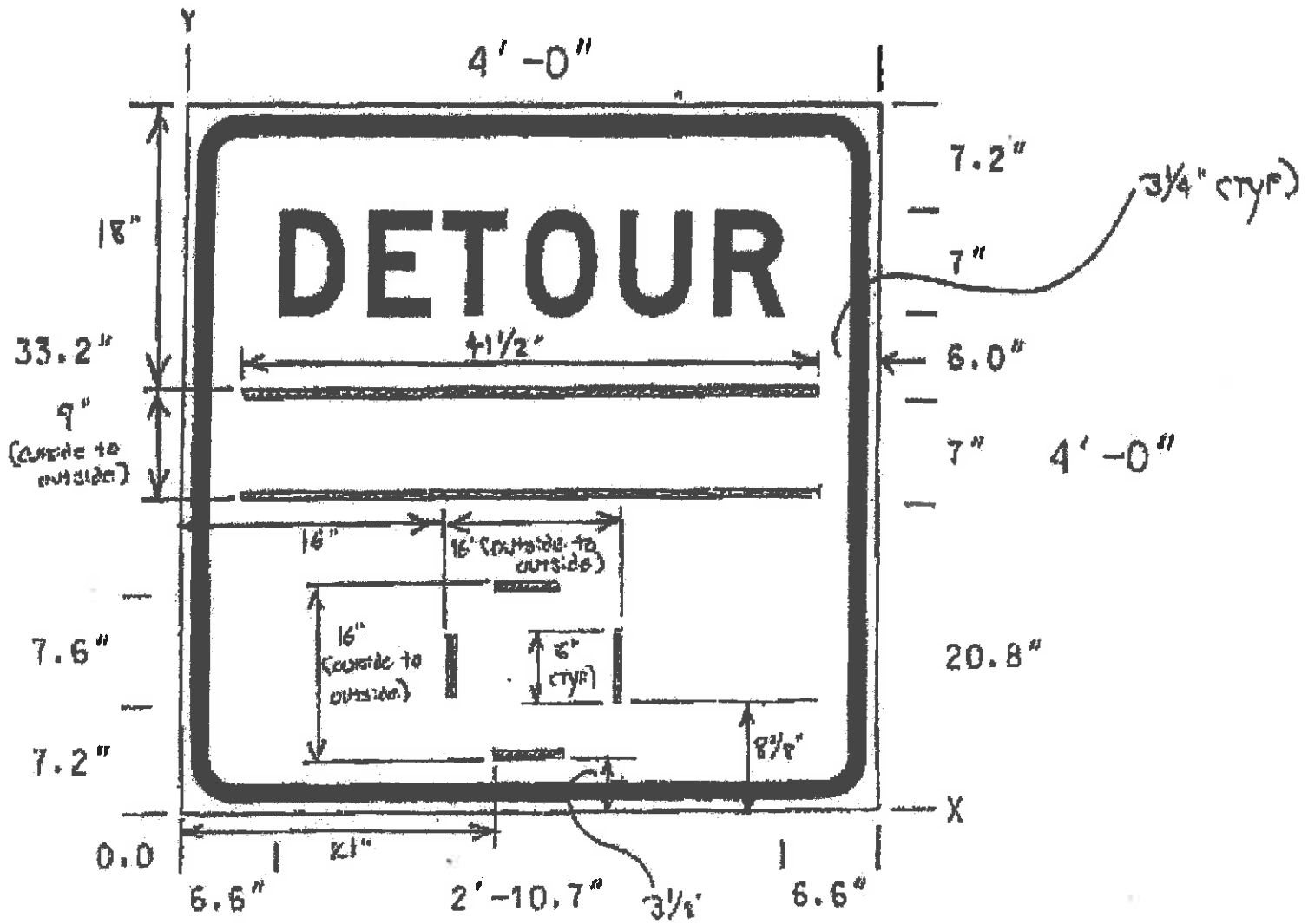
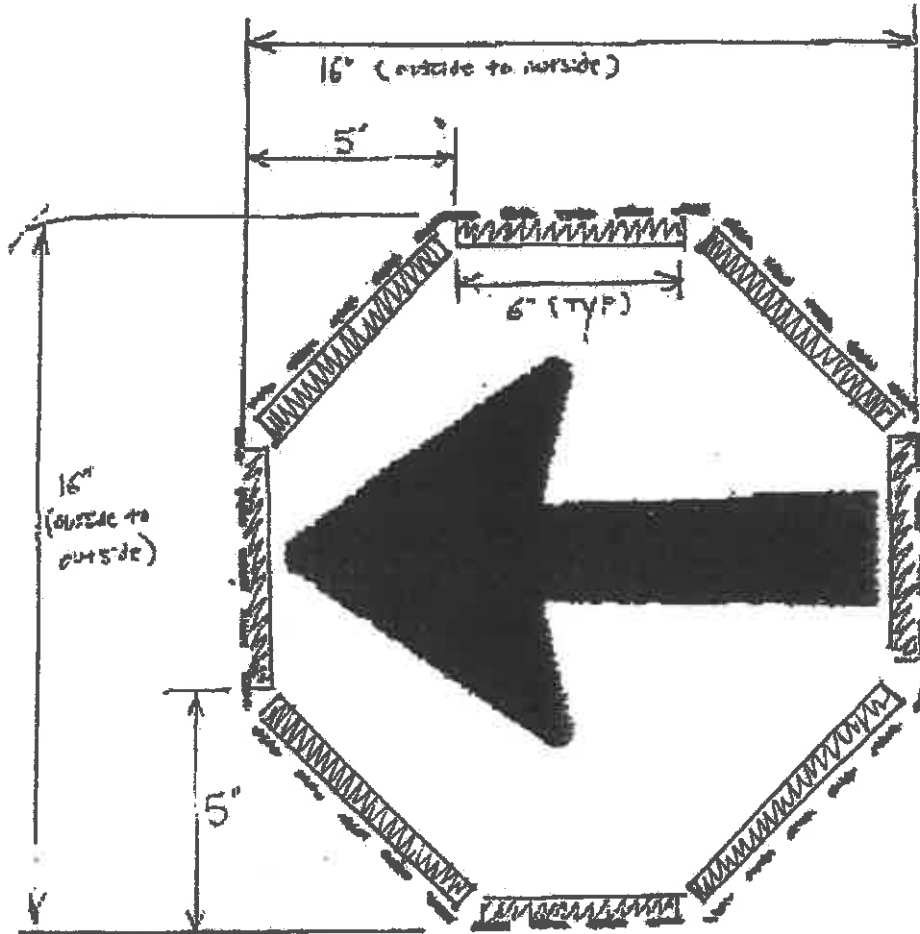
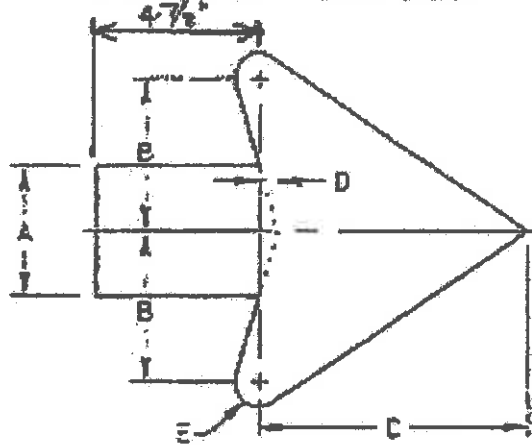

EXHIBIT AA

BID ITEM 26 - MODIFIED STANDARD DETAIL (CONTINUED)



ARROW DETAIL



A	B	C	D	E
3 1/2	4	7 1/8	3/16	3/16

EXHIBIT BB

48x48 SQUARE - CORNER POCKET AND RIB CONFIGURATION

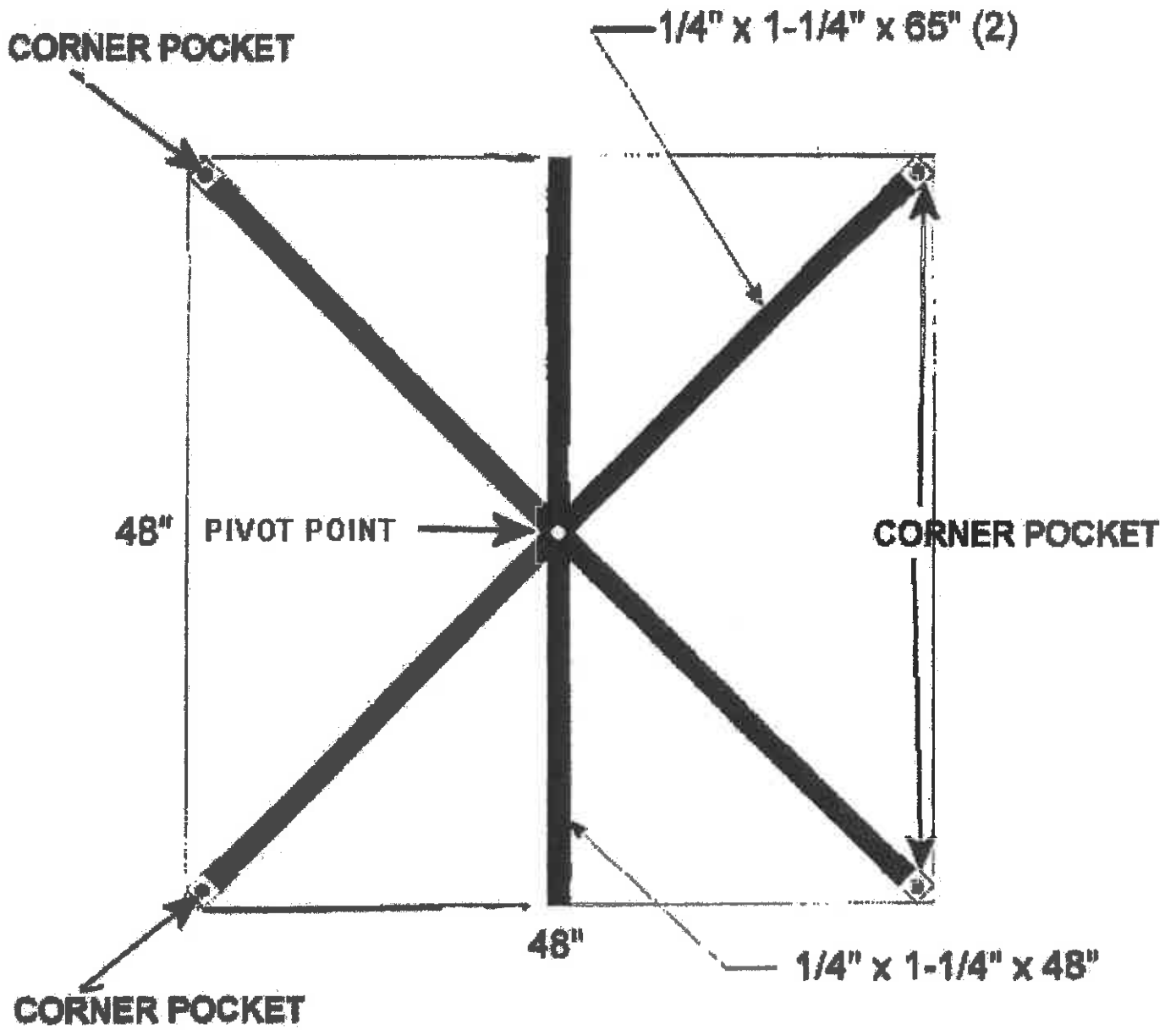

EXHIBIT CC

SUPPLEMENTAL ROLL-UP SIGN ORDERING INFORMATION

The following is a listing of diamond shaped signs for which alternate messages may be displayed using supplemental overlay plaques. All such signs are to be ordered with hook & loop strips under item numbers 33, 34, 35, or 36. In addition, all such signs are to be ordered with the indicated "base" sign message being the permanent sign message. All alternate messages to the "base" sign message are to be accomplished by using the supplemental overlay plaques supplied under item numbers 37 and 38.

Fabrication Number	Fab Book Description	Applicable Sizes	"Base" Sign Message *	Additional Notes
W4-7	THRU TRAFFIC MERGE LEFT (RIGHT)	36" and 48"	THRU TRAFFIC MERGE RIGHT	
W5-1	ROAD (LANE) (RAMP) NARROWS	36" and 48"	ROAD NARROWS	
W5-1C	NARROW ROAD (LANE) (LANES)	36" only	NARROW ROAD	
W8-9	LOW (NO) SHOULDER	36" and 48"	LOW SHOULDER	
W8-1	LEFT (RIGHT) LANE ENDS	36" and 48"	RIGHT LANE ENDS	
W20-1	ROAD WORK AHEAD (VARIOUS ALTERNATE MESSAGES)	36" only	ROAD WORK <u>AHEAD</u>	Use item #36
W20-1	ROAD WORK AHEAD (VARIOUS ALTERNATE MESSAGES)	48"	ROAD WORK <u>1 MILE</u>	Use item #34 No 8x28 "AHEAD" plaques are to be ordered for use with this sign
W20-2	DETOUR 1000 FT (VARIOUS ALTERNATE MESSAGES)	36" and 48"	DETOUR <u>1000 FT</u>	No 8x28 "AHEAD" plaques are to be ordered for use with this sign in the 48" size
W20-3	ROAD CLOSED 1000 FT (VARIOUS ALTERNATE MESSAGES)	36" and 48"	ROAD CLOSED <u>1000 FT</u>	No 8x28 "AHEAD" plaques are to be ordered for use with this sign in the 48" size
W20-4	ONE LANE ROAD 1000 FT (VARIOUS ALTERNATE MESSAGES)	36" and 48"	ONE LANE ROAD <u>1000 FT</u>	No 8x28 "AHEAD" plaques are to be ordered for use with this sign in the 48" size
W20-5	RIGHT (LEFT) (CENTER) LANE CLOSED 1500 FT (VARIOUS ALTERNATE MESSAGES)	36" and 48"	RIGHT LANE CLOSED <u>1500 FT</u>	No 8x28 "AHEAD" plaques are to be ordered for use with this sign in the 48" size
W20-5A	RIGHT (LEFT) TWO LANES CLOSED 1500 FT (VARIOUS ALTERNATE MESSAGES)	36" and 48"	RIGHT TWO LANES CLOSED <u>1500 FT</u>	No 8x28 "AHEAD" plaques are to be ordered for use with this sign in the 48" size
W20-10	SHOULDER CLOSED 1000 FT (VARIOUS ALTERNATE MESSAGES)	36" and 48"	SHOULDER CLOSED <u>1000 FT</u>	No 8x28 "AHEAD" plaques are to be ordered for use with this sign in the 48" size
W20-11	LANE SHIFT 1000 FT (VARIOUS ALTERNATE MESSAGES)	36" and 48"	LANE SHIFT <u>1000 FT</u>	No 8x28 "AHEAD" plaques are to be ordered for use with this sign in the 48" size
W21-5A	RIGHT (LEFT) SHOULDER CLOSED	36" and 48"	RIGHT SHOULDER CLOSED	
W21-5B	RIGHT (LEFT) SHOULDER CLOSED 1000 FT (VARIOUS ALTERNATE MESSAGES)	36" and 48"	RIGHT SHOULDER CLOSED <u>1000 FT</u>	No 8x28 "AHEAD" plaques are to be ordered for use with this sign in the 48" size
W21-5C	SHOULDER WORK AHEAD (VARIOUS ALTERNATE MESSAGES)	36" only	SHOULDER WORK <u>AHEAD</u>	
W21-5C	SHOULDER WORK AHEAD (VARIOUS ALTERNATE MESSAGES)	48"	SHOULDER WORK <u>500 FT</u>	No 8x28 "AHEAD" plaques are to be ordered for use with this sign
W21-7	UTILITY WORK AHEAD (VARIOUS ALTERNATE MESSAGES)	36" only	UTILITY WORK <u>AHEAD</u>	
W21-7	UTILITY WORK AHEAD (VARIOUS ALTERNATE MESSAGES)	48"	UTILITY WORK <u>1 MILE</u>	No 8x28 "AHEAD" plaques are to be ordered for use with this sign
W22-1	BLASTING ZONE AHEAD (VARIOUS ALTERNATE MESSAGES)	36" only	BLASTING ZONE <u>AHEAD</u>	
W22-1	BLASTING ZONE AHEAD (VARIOUS ALTERNATE MESSAGES)	48"	BLASTING ZONE <u>1500 FT</u>	No 8x28 "AHEAD" plaques are to be ordered for use with this sign

* For each sign shown in this column, the underlined portion(s) of the sign text shall have the "hook" strip portion of hook & loop strips installed above & below the text in accordance with the Contract specifications so that overlay plaques may be applied if needed.

36X18 HORIZONTAL RECTANGLE - CORNER POCKET AND RIB CONFIGURATION

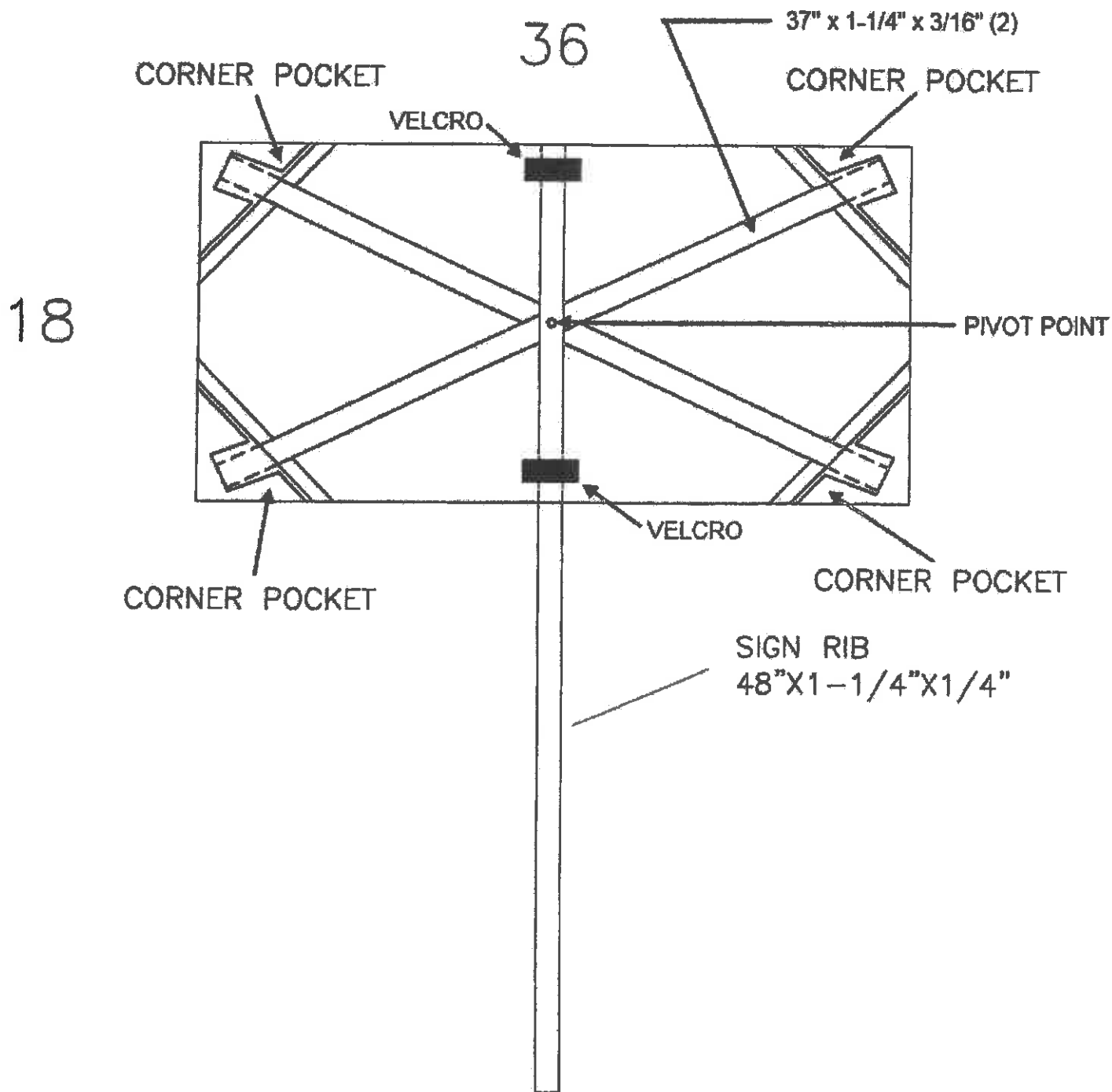

PRODUCT COMPLIANCE CHECKLIST FORM

This form shall be completed in its' entirety by the vendor, and submitted as part of the vendor's bid package.

EXHIBIT EE

SECTION I - ITEM #1 - COMPACT PORTABLE SIGN STAND

1) This section not applicable (this item is not being bid)?

Yes

2) Stand manufacturer: Eastern Metal

3) Stand trade name and model number: C-801-L-KLSH

4) Stand is FHWA approved as meeting all applicable NCHRP-350 or MASH crash testing requirements when used with all signs described under bid items 3 through 39 (except Item #24), and on all roadways (Speed Limit 25 MPH to 70 MPH)?

Yes	No
X	

5) List all applicable individual FHWA acceptance letter reference numbers below for which statement #4 is based on.

6) Stand capable of holding 36" and 48" diamond roll-up signs a minimum of 12" off the ground?

Yes	No
X	

7) By bidding this Contract, Vendor agrees to extend to the WVDOH a four (4) year warranty against defects in workmanship, parts, and materials?

Yes	No
X	

PRINT NAME: Lisa P. Booth

SIGN NAME: Lisa P Booth

NAME OF VENDOR: Highway Safety

DATE: 3-17-15

PRODUCT COMPLIANCE CHECKLIST FORM

This form shall be completed in its' entirety by the vendor, and submitted as part of the vendor's bid package.

EXHIBIT FF

SECTION II - ITEM #2 - LARGE, ALUMINUM SUBSTRATE SIGN AND OVERSIZED ROLL-UP SIGN PORTABLE SIGN STAND

1) This section not applicable (this item is not being bid)?

Yes

2) Stand manufacturer: Eastern Metal

3) Stand trade name and model number: X-553-DD

4) Stand is FHWA approved as meeting all applicable NCHRP-350 or MASH crash testing requirements when used with all signs described under bid items 3 through 39, and 80 ga aluminum substrate signs not larger than 48X48 (DIAMOND), 60X30 (HORIZONTAL RECTANGLE), 36X60 (VERTICAL RECTANGLE), 48" (OCTAGON), 48" (SQUARE), OR 48" (TRIANGLE), and on all roadways (Speed Limit 25 MPH to 70 MPH)?

Yes	No
X	

5) List all applicable individual FHWA acceptance letter reference numbers below for which statement #4 is based on.

6) Stand, as supplied, capable of holding 0.080 aluminum 48" diamond signs, 48" octagon signs, 48" triangle signs, 36x60 vertical rectangle signs, 60x30 horizontal rectangle signs, and smaller signs, as well as roll-up signs as large as 60x60 square?

Yes	No
X	

7) Stand designed such that the sign mounting height will be 12 in to 24 in off of the ground?

Yes	No
X	

8) Stand to be supplied with a adjustable mast, adjustable brackets for rigid signs, and an adjustable roll-up sign bracket?

Yes	No
X	

9) Supplied roll-up sign bracket accommodates all of the horizontal rib sizes detailed as part of this Contract?

Yes	No
X	

10) By bidding this Contract, Vendor agrees to extend to the WVDOH a four (4) year warranty against defects in workmanship, parts, and materials?

Yes	No
X	

PRINT NAME: Lisa P. Booth

SIGN NAME: Lisa P Booth

NAME OF VENDOR: Highway Safety

DATE: 3-17-15

PRODUCT COMPLIANCE CHECKLIST FORM

This form shall be completed in its' entirety by the vendor, and submitted as part of the vendor's bid package.

EXHIBIT GG

SECTION III - ITEMS 3 THROUGH 39 - ROLL-UP SIGNS

1) This section not applicable (these items not being bid)?

Yes

2) Sign manufacturer: Eastern Metal

3) Sheeting manufacturer and product code for sheeting being used: 3M DRAFLDL

4) Manufacturer's handling and manufacturing methods are in compliance with the sheeting manufacturer's recommendations?

Yes	No
X	

5) In cases where the splicing of roll-up sign material fabric is required as noted within the Contract specifications, the splice is to be accomplished by the method described within the Contract specifications?

Yes	No
X	

6) All vertical, horizontal, or diagonal ribs designed to pivot about a metallic (rivet) pivot point meeting the specifications herein?

Yes	No
X	

7) With the exception of signs having a vertical rib extending below the sign, the ends of the ribs on all signs to slide into a cloth pocket meeting the material, manufacturing, and dimensional requirements contained herein?

Yes	No
X	

8) Vertical ribs of all non-diamond signs (excluding stop signs) to be attached and secured to signs using Hook & Loop material as described herein when specified?

Yes	No
X	

9) All metal parts of the vinyl flag deployment system, when required, to be stainless steel, electro-deposit zinc coated steel, hot-dip galvanized steel, or powder coated steel?

Yes	No
X	

10) Flag staffs to be made using fiberglass or other material similar to the sign ribs, and have a minimum section modulus equal to that of a 1/8" thick x 1" wide fiberglass rib (0.002604 in³)?

Yes	No
X	

11) Flag staffs sufficiently long enough to hold the flags completely above the sign face?

Yes	No
X	

12) No hand tightening of any components required to hold the flags in the deployed position?

Yes	No
X	

13) When deployed, the two flags extend symmetrically (about the vertical centerline) up and out from their mounting point along the vertical rib, with the flags held in position completely above the sign face, and with each staff at an angle of 30 to 60 degrees from the vertical centerline of the sign?

Yes	No
X	

14) For particular signs and overlay plaques requiring hook and loop (H&L) strips for temporary overlay attachment, the hook ("coarse") side of the H&L is attached to the sign faces, and the loop ("fuzzy") side of the H&L is attached to the back face of the overlays?

Yes	No
X	

15) All signs to present a finished, professional look to the motorist with no sagging of the sign material?

Yes	No
X	

16) Signs to include anti-kite H&L loops attached to the back faces of the signs for connection around the ribs of the signs (manufacturer shall determine appropriate locations for anti-kite H&L strips)?

Yes	No
X	

17) H&L material to be fastened near the vertical center of one of the horizontal end points on each sign, and to be oriented such that when the sign is rolled up on the vertical rib the H&L material will encircle the sign and hold it in the rolled up storing position?

Yes	No
X	

18) All signs to have a permanent sticker affixed to the non-reflective face with the wording "PROPERTY OF WVDOH" in 1/2" minimum legend size?

Yes	No
X	

19) Rib sizes, rib locations, rib lengths, corner pocket locations, and rotation point locations to be in substantial conformance as shown in the supplemental drawings included within the Contract?

Yes	No
X	

20) Identification to be printed in the margin for convenient indication of the sign message when the sign is rolled up for storage?

Yes	No
X	

PRINT NAME: Lisa P Booth

SIGN NAME: Lisa P Booth

NAME OF VENDOR: Highway Safety

DATE: 3-17-15

PRODUCT COMPLIANCE CHECKLIST FORM

This form shall be completed in its' entirety by the vendor, and submitted as part of the vendor's bid package.

SECTION IV - ITEMS 40 THROUGH 55 - ROLL-UP SIGNS

1) This section not applicable (these items not being bid)?

Yes

2) Sign manufacturer: Eastern Metal

3) Sheeting manufacturer and product code for sheeting being used: 3M DRAFLOR

4) Sheeting manufacturers fluorescent-orange material is currently listed on the WVDOH APL for Retroreflective Sign Sheeting?

Yes	No
X	

5) Manufacturer's handling and manufacturing methods are in compliance with the sheeting manufacturer's recommendations?

Yes	No
X	

6) In cases where the splicing of roll-up sign material fabric is required as noted within the Contract specifications, the splice is to be accomplished by the method described within the Contract specifications?

Yes	No
X	

7) All vertical, horizontal, or diagonal ribs designed to pivot about a metallic (rivet) pivot point meeting the specifications herein?

Yes	No
X	

8) With the exception of signs having a vertical rib extending below the sign, the ends of the ribs on all signs to slide into a cloth pocket meeting the material, manufacturing, and dimensional requirements contained herein?

Yes	No
X	

9) Vertical ribs of all non-diamond signs to be attached and secured to signs using Hook & Loop material as described herein when specified?

Yes	No
X	

10) For particular signs and overlay plaques requiring hook and loop (H&L) strips for temporary overlay attachment, the hook ("coarse") side of the H&L is attached to the sign faces, and the loop ("fuzzy") side of the H&L is attached to the back face of the overlays?

Yes	No
X	

11) All signs to present a finished, professional look to the motorist with no sagging of the sign material?

Yes	No
X	

12) Signs to include anti-kite H&L loops attached to the back faces of the signs for connection around the ribs of the signs (manufacturer shall determine appropriate locations for anti-kite H&L strips)?

Yes	No
X	

13) H&L material to be fastened near the vertical center of one of the horizontal end points on each sign, and to be oriented such that when the sign is rolled up on the vertical rib the H&L material will encircle the sign and hold it in the rolled up storing position?

Yes	No
X	

14) All signs to have a permanent sticker affixed to the non-reflective face with the wording "PROPERTY OF WVDOH" in 1/2" minimum legend size?

Yes	No
X	

15) Rib sizes, rib locations, rib lengths, corner pocket locations, and rotation point locations to be in substantial conformance as shown in the supplemental drawings included within the Contract?

Yes	No
X	

16) Identification to be printed in the margin for convenient indication of the sign message when the sign is rolled up for storage?

Yes	No
X	

PRINT NAME: Lisa P. Booth

SIGN NAME: Lisa P Booth

NAME OF VENDOR: Highway Safety

DATE: 3-17-15

VENDOR PREFERENCE CERTIFICATE

Certification and application* is hereby made for Preference in accordance with West Virginia Code, §5A-3-37. (Does not apply to construction contracts). West Virginia Code, §5A-3-37, provides an opportunity for qualifying vendors to request (at the time of bid) preference for their residency status. Such preference is an evaluation method only and will be applied only to the cost bid in accordance with the West Virginia Code. This certificate for application is to be used to request such preference. The Purchasing Division will make the determination of the Vendor Preference, if applicable.

- 1. Application is made for 2.5% vendor preference for the reason checked: Bidder is an individual resident vendor and has resided continuously in West Virginia for four (4) years immediately preceding the date of this certification; or, Bidder is a partnership, association or corporation resident vendor and has maintained its headquarters or principal place of business continuously in West Virginia for four (4) years immediately preceding the date of this certification; or 80% of the ownership interest of Bidder is held by another individual, partnership, association or corporation resident vendor who has maintained its headquarters or principal place of business continuously in West Virginia for four (4) years immediately preceding the date of this certification; or, Bidder is a nonresident vendor which has an affiliate or subsidiary which employs a minimum of one hundred state residents and which has maintained its headquarters or principal place of business within West Virginia continuously for the four (4) years immediately preceding the date of this certification; or,
2. Application is made for 2.5% vendor preference for the reason checked: Bidder is a resident vendor who certifies that, during the life of the contract, on average at least 75% of the employees working on the project being bid are residents of West Virginia who have resided in the state continuously for the two years immediately preceding submission of this bid; or,
3. Application is made for 2.5% vendor preference for the reason checked: Bidder is a nonresident vendor employing a minimum of one hundred state residents or is a nonresident vendor with an affiliate or subsidiary which maintains its headquarters or principal place of business within West Virginia employing a minimum of one hundred state residents who certifies that, during the life of the contract, on average at least 75% of the employees or Bidder's affiliate's or subsidiary's employees are residents of West Virginia who have resided in the state continuously for the two years immediately preceding submission of this bid; or,
4. Application is made for 5% vendor preference for the reason checked: Bidder meets either the requirement of both subdivisions (1) and (2) or subdivision (1) and (3) as stated above; or,
5. Application is made for 3.5% vendor preference who is a veteran for the reason checked: Bidder is an individual resident vendor who is a veteran of the United States armed forces, the reserves or the National Guard and has resided in West Virginia continuously for the four years immediately preceding the date on which the bid is submitted; or,
6. Application is made for 3.5% vendor preference who is a veteran for the reason checked: Bidder is a resident vendor who is a veteran of the United States armed forces, the reserves or the National Guard, if, for purposes of producing or distributing the commodities or completing the project which is the subject of the vendor's bid and continuously over the entire term of the project, on average at least seventy-five percent of the vendor's employees are residents of West Virginia who have resided in the state continuously for the two immediately preceding years.
7. Application is made for preference as a non-resident small, women- and minority-owned business, in accordance with West Virginia Code §5A-3-59 and West Virginia Code of State Rules. Bidder has been or expects to be approved prior to contract award by the Purchasing Division as a certified small, women- and minority-owned business.

Bidder understands if the Secretary of Revenue determines that a Bidder receiving preference has failed to continue to meet the requirements for such preference, the Secretary may order the Director of Purchasing to: (a) reject the bid; or (b) assess a penalty against such Bidder in an amount not to exceed 5% of the bid amount and that such penalty will be paid to the contracting agency or deducted from any unpaid balance on the contract or purchase order.

By submission of this certificate, Bidder agrees to disclose any reasonably requested information to the Purchasing Division and authorizes the Department of Revenue to disclose to the Director of Purchasing appropriate information verifying that Bidder has paid the required business taxes, provided that such information does not contain the amounts of taxes paid nor any other information deemed by the Tax Commissioner to be confidential.

Under penalty of law for false swearing (West Virginia Code, §61-5-3), Bidder hereby certifies that this certificate is true and accurate in all respects; and that if a contract is issued to Bidder and if anything contained within this certificate changes during the term of the contract, Bidder will notify the Purchasing Division in writing immediately.

Bidder: Highway Safety
Date: 3-17-15

Signed: Lisa P. Boddie
Title: President

STATE OF WEST VIRGINIA
Purchasing Division**PURCHASING AFFIDAVIT**

MANDATE: Under W. Va. Code §5A-3-10a, no contract or renewal of any contract may be awarded by the state or any of its political subdivisions to any vendor or prospective vendor when the vendor or prospective vendor or a related party to the vendor or prospective vendor is a debtor and: (1) the debt owed is an amount greater than one thousand dollars in the aggregate; or (2) the debtor is in employer default.

EXCEPTION: The prohibition listed above does not apply where a vendor has contested any tax administered pursuant to chapter eleven of the W. Va. Code, workers' compensation premium, permit fee or environmental fee or assessment and the matter has not become final or where the vendor has entered into a payment plan or agreement and the vendor is not in default of any of the provisions of such plan or agreement.

DEFINITIONS:

"Debt" means any assessment, premium, penalty, fine, tax or other amount of money owed to the state or any of its political subdivisions because of a judgment, fine, permit violation, license assessment, defaulted workers' compensation premium, penalty or other assessment presently delinquent or due and required to be paid to the state or any of its political subdivisions, including any interest or additional penalties accrued thereon.

"Employer default" means having an outstanding balance or liability to the old fund or to the uninsured employers' fund or being in policy default, as defined in W. Va. Code § 23-2c-2, failure to maintain mandatory workers' compensation coverage, or failure to fully meet its obligations as a workers' compensation self-insured employer. An employer is not in employer default if it has entered into a repayment agreement with the Insurance Commissioner and remains in compliance with the obligations under the repayment agreement.

"Related party" means a party, whether an individual, corporation, partnership, association, limited liability company or any other form or business association or other entity whatsoever, related to any vendor by blood, marriage, ownership or contract through which the party has a relationship of ownership or other interest with the vendor so that the party will actually or by effect receive or control a portion of the benefit, profit or other consideration from performance of a vendor contract with the party receiving an amount that meets or exceeds five percent of the total contract amount.

AFFIRMATION: By signing this form, the vendor's authorized signer affirms and acknowledges under penalty of law for false swearing (W. Va. Code §61-5-3) that neither vendor nor any related party owe a debt as defined above and that neither vendor nor any related party are in employer default as defined above, unless the debt or employer default is permitted under the exception above.

WITNESS THE FOLLOWING SIGNATURE:

Vendor's Name: Highway Safety
Authorized Signature: [Signature] Date: 3-17-15

State of WV

County of Wayne, to-wit:

Taken, subscribed, and sworn to before me this 17th day of March, 2015

My Commission expires 10-4, 2020

AFFIX SEAL HERE

NOTARY PUBLIC

[Signature]

Purchasing Affidavit (Revised 07/01/2012)

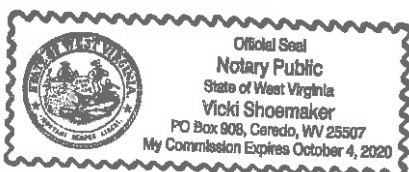
**NOTE:**

Vendor and Notary's date must be the same.
Notary required to AFFIX SEAL on Purchasing Affidavit.