



Purchasing Division
 2019 Washington Street East
 Post Office Box 50130
 Charleston, WV 25305-0130

State of West Virginia
 Request for Quotation
 32 - Reclamation

TOTAL
 \$ 720,000 -

Proc Folder: 18934

Doc Description: Addendum No 03: Buffalo Coal Co.,S-52-80, DEP16308 Reclam.

Proc Type: Central Purchase Order

Date Issued	Solicitation Closes	Solicitation No	Version
2014-12-08	2014-12-30 13:30:00	CRFQ 0313 DEP1500000021	4

BID RECEIVING LOCATION

BID CLERK
 DEPARTMENT OF ADMINISTRATION
 PURCHASING DIVISION
 2019 WASHINGTON ST E
 CHARLESTON WV 25305
 US

VENDOR

Vendor Name, Address and Telephone Number:

12/30/14 11:40:37
 West Virginia Purchasing Division

FOR INFORMATION CONTACT THE BUYER

Jamie H Adkins
 (304) 926-0499
 jamie.h.adkins@wv.gov

Signature X

FEIN # 55-0580174

DATE 12/30/14

All offers subject to all terms and conditions contained in this solicitation

INVOICE TO		SHIP TO	
ENVIRONMENTAL PROTECTION OFFICE OF SPECIAL RECLAMATION 47 SCHOOL ST, STE 301 PHILIPPI WV26416 US		ENVIRONMENTAL PROTECTION OFFICE OF SPECIAL RECLAMATION 47 SCHOOL ST, STE 301 PHILIPPI WV 26416-9998 US	

Line	Comm Ln Desc	Qty	Unit Issue	Unit Price	Total Price
1	Mobilization and Demobilization	1	L.S.	10,000	10,000

Comm Code	Manufacturer	Specification	Model #
77111603			

Extended Description :
Mobilization and Demobilization (Cannot be more than 10% of TOTAL AMOUNT BID for the Project)

INVOICE TO		SHIP TO	
ENVIRONMENTAL PROTECTION OFFICE OF SPECIAL RECLAMATION 47 SCHOOL ST, STE 301 PHILIPPI WV26416 US		ENVIRONMENTAL PROTECTION OFFICE OF SPECIAL RECLAMATION 47 SCHOOL ST, STE 301 PHILIPPI WV 26416-9998 US	

Line	Comm Ln Desc	Qty	Unit Issue	Unit Price	Total Price
2	Construction Layout Stakes	1.00000	LS	5,000	5,000

Comm Code	Manufacturer	Specification	Model #
77111603			

Extended Description :
Construction Layout Stakes (Cannot be more than 5% of TOTAL AMOUNT BID for the Project)

INVOICE TO		SHIP TO	
ENVIRONMENTAL PROTECTION OFFICE OF SPECIAL RECLAMATION 47 SCHOOL ST, STE 301 PHILIPPI WV26416 US		ENVIRONMENTAL PROTECTION OFFICE OF SPECIAL RECLAMATION 47 SCHOOL ST, STE 301 PHILIPPI WV 26416-9998 US	

Line	Comm Ln Desc	Qty	Unit Issue	Unit Price	Total Price
3	Quality Control	1.00000	LS	5,000	5,000

Comm Code	Manufacturer	Specification	Model #
77111603			

Extended Description :

Quality Control (Cannot be more than 5% of TOTALAMOUNT BID for the Project)

INVOICE TO		SHIP TO	
ENVIRONMENTAL PROTECTION OFFICE OF SPECIAL RECLAMATION 47 SCHOOL ST, STE 301 PHILIPPI WV26416 US		ENVIRONMENTAL PROTECTION OFFICE OF SPECIAL RECLAMATION 47 SCHOOL ST, STE 301 PHILIPPI WV 26416-9998 US	

Line	Comm Ln Desc	Qty	Unit Issue	Unit Price	Total Price
4	Site Preparation	1.00000	LS	33,920	33,920

Comm Code	Manufacturer	Specification	Model #
77111603			

Extended Description :

Site Preparation (Cannot be more than 10% of TOTALAMOUNT BID for the Project)

INVOICE TO		SHIP TO	
ENVIRONMENTAL PROTECTION OFFICE OF SPECIAL RECLAMATION 47 SCHOOL ST, STE 301 PHILIPPI WV26416 US		ENVIRONMENTAL PROTECTION OFFICE OF SPECIAL RECLAMATION 47 SCHOOL ST, STE 301 PHILIPPI WV 26416-9998 US	

Line	Comm Ln Desc	Qty	Unit Issue	Unit Price	Total Price
5	Incidental Stone	500.00000	TON	40	20,000

Comm Code	Manufacturer	Specification	Model #
77111603			

Extended Description :

Incidental Stone

INVOICE TO		SHIP TO	
ENVIRONMENTAL PROTECTION OFFICE OF SPECIAL RECLAMATION 47 SCHOOL ST, STE 301 PHILIPPI WV26416 US		ENVIRONMENTAL PROTECTION OFFICE OF SPECIAL RECLAMATION 47 SCHOOL ST, STE 301 PHILIPPI WV 26416-9998 US	

Line	Comm Ln Desc	Qty	Unit Issue	Unit Price	Total Price
6	Fence	2800.00000	LF	12	33,600

Comm Code	Manufacturer	Specification	Model #
77111603			

Extended Description :
Fence

INVOICE TO		SHIP TO	
ENVIRONMENTAL PROTECTION OFFICE OF SPECIAL RECLAMATION 47 SCHOOL ST, STE 301 PHILIPPI WV26416 US		ENVIRONMENTAL PROTECTION OFFICE OF SPECIAL RECLAMATION 47 SCHOOL ST, STE 301 PHILIPPI WV 26416-9998 US	

Line	Comm Ln Desc	Qty	Unit Issue	Unit Price	Total Price
7	Farm Gate	6.00000	EA	1,100	6,600

Comm Code	Manufacturer	Specification	Model #
77111603			

Extended Description :
Farm Gate

INVOICE TO		SHIP TO	
ENVIRONMENTAL PROTECTION OFFICE OF SPECIAL RECLAMATION 47 SCHOOL ST, STE 301 PHILIPPI WV26416 US		ENVIRONMENTAL PROTECTION OFFICE OF SPECIAL RECLAMATION 47 SCHOOL ST, STE 301 PHILIPPI WV 26416-9998 US	

Line	Comm Ln Desc	Qty	Unit Issue	Unit Price	Total Price
8	Access Road Number One	1000.00000	LF	16	16,000

Comm Code	Manufacturer	Specification	Model #
77111603			

Extended Description :
Access Road Number One

INVOICE TO	SHIP TO
ENVIRONMENTAL PROTECTION OFFICE OF SPECIAL RECLAMATION 47 SCHOOL ST, STE 301 PHILIPPI WV26416 US	ENVIRONMENTAL PROTECTION OFFICE OF SPECIAL RECLAMATION 47 SCHOOL ST, STE 301 PHILIPPI WV 26416-9998 US

Line	Comm Ln Desc	Qty	Unit Issue	Unit Price	Total Price
9	Straw Wattles	6200.00000	LF	1.5	6,200

Comm Code	Manufacturer	Specification	Model #
77111603			

Extended Description :
Straw Wattles

INVOICE TO	SHIP TO
ENVIRONMENTAL PROTECTION OFFICE OF SPECIAL RECLAMATION 47 SCHOOL ST, STE 301 PHILIPPI WV26416 US	ENVIRONMENTAL PROTECTION OFFICE OF SPECIAL RECLAMATION 47 SCHOOL ST, STE 301 PHILIPPI WV 26416-9998 US

Line	Comm Ln Desc	Qty	Unit Issue	Unit Price	Total Price
10	Silt Fence	2100.00000	LF	1.5	2,100

Comm Code	Manufacturer	Specification	Model #
77111603			

Extended Description :
Silt Fence

INVOICE TO		SHIP TO	
ENVIRONMENTAL PROTECTION OFFICE OF SPECIAL RECLAMATION 47 SCHOOL ST, STE 301 PHILIPPI WV26416 US		ENVIRONMENTAL PROTECTION OFFICE OF SPECIAL RECLAMATION 47 SCHOOL ST, STE 301 PHILIPPI WV 26416-9998 US	

Line	Comm Ln Desc	Qty	Unit Issue	Unit Price	Total Price
11	Revegetation (Plan View)	41.00000	ACRE	1,000	41,000

Comm Code	Manufacturer	Specification	Model #
77111603			

Extended Description :
Revegetation (Plan View)

INVOICE TO		SHIP TO	
ENVIRONMENTAL PROTECTION OFFICE OF SPECIAL RECLAMATION 47 SCHOOL ST, STE 301 PHILIPPI WV26416 US		ENVIRONMENTAL PROTECTION OFFICE OF SPECIAL RECLAMATION 47 SCHOOL ST, STE 301 PHILIPPI WV 26416-9998 US	

Line	Comm Ln Desc	Qty	Unit Issue	Unit Price	Total Price
12	2.0 Ft. Deep V shaped Riprap Ditch	800.00000	LF	45	36,000

Comm Code	Manufacturer	Specification	Model #
77111603			

Extended Description :
2.0 Ft. Deep V Shaped Grouted Riprap Ditch

INVOICE TO		SHIP TO	
ENVIRONMENTAL PROTECTION OFFICE OF SPECIAL RECLAMATION 47 SCHOOL ST, STE 301 PHILIPPI WV26416 US		ENVIRONMENTAL PROTECTION OFFICE OF SPECIAL RECLAMATION 47 SCHOOL ST, STE 301 PHILIPPI WV 26416-9998 US	

Line	Comm Ln Desc	Qty	Unit Issue	Unit Price	Total Price
13	2.5 Ft. Deep V shaped Riprap Ditch	1550.00000	LF	50	77,500

Comm Code	Manufacturer	Specification	Model #
77111603			

Extended Description :

2.5 Ft. Deep V Shaped Grouted Riprap Ditch

INVOICE TO	SHIP TO
ENVIRONMENTAL PROTECTION OFFICE OF SPECIAL RECLAMATION 47 SCHOOL ST, STE 301 PHILIPPI WV26416 US	ENVIRONMENTAL PROTECTION OFFICE OF SPECIAL RECLAMATION 47 SCHOOL ST, STE 301 PHILIPPI WV 26416-9998 US

Line	Comm Ln Desc	Qty	Unit Issue	Unit Price	Total Price
14	3.0 Ft. Deep V shaped Riprap Ditch	500.00000	LF	105	52,500

Comm Code	Manufacturer	Specification	Model #
77111603			

Extended Description :

3.0 Ft. Deep V Shaped Grouted Riprap Ditch

INVOICE TO	SHIP TO
ENVIRONMENTAL PROTECTION OFFICE OF SPECIAL RECLAMATION 47 SCHOOL ST, STE 301 PHILIPPI WV26416 US	ENVIRONMENTAL PROTECTION OFFICE OF SPECIAL RECLAMATION 47 SCHOOL ST, STE 301 PHILIPPI WV 26416-9998 US

Line	Comm Ln Desc	Qty	Unit Issue	Unit Price	Total Price
15	Spillway Number One	1.00000	LS	3,000	3,000

Comm Code	Manufacturer	Specification	Model #
77111603			

Extended Description :

Spillway Number One

INVOICE TO		SHIP TO	
ENVIRONMENTAL PROTECTION OFFICE OF SPECIAL RECLAMATION 47 SCHOOL ST, STE 301 PHILIPPI WV26416 US		ENVIRONMENTAL PROTECTION OFFICE OF SPECIAL RECLAMATION 47 SCHOOL ST, STE 301 PHILIPPI WV 26416-9998 US	

Line	Comm Ln Desc	Qty	Unit Issue	Unit Price	Total Price
16	Spillway Number Two	1.00000	LS	3,000	3,000

Comm Code	Manufacturer	Specification	Model #
77111603			

Extended Description :
Spillway Number Two

INVOICE TO		SHIP TO	
ENVIRONMENTAL PROTECTION OFFICE OF SPECIAL RECLAMATION 47 SCHOOL ST, STE 301 PHILIPPI WV26416 US		ENVIRONMENTAL PROTECTION OFFICE OF SPECIAL RECLAMATION 47 SCHOOL ST, STE 301 PHILIPPI WV 26416-9998 US	

Line	Comm Ln Desc	Qty	Unit Issue	Unit Price	Total Price
17	Spillway Number Three	1.00000	LS	3,000	3,000

Comm Code	Manufacturer	Specification	Model #
77111603			

Extended Description :
Spillway Number Three

INVOICE TO		SHIP TO	
ENVIRONMENTAL PROTECTION OFFICE OF SPECIAL RECLAMATION 47 SCHOOL ST, STE 301 PHILIPPI WV26416 US		ENVIRONMENTAL PROTECTION OFFICE OF SPECIAL RECLAMATION 47 SCHOOL ST, STE 301 PHILIPPI WV 26416-9998 US	

Line	Comm Ln Desc	Qty	Unit Issue	Unit Price	Total Price
18	Spillway Number Four	1.00000	LS	3,000	3,000

Comm Code	Manufacturer	Specification	Model #
77111603			

Extended Description :

Spillway Number Four

INVOICE TO	SHIP TO
ENVIRONMENTAL PROTECTION OFFICE OF SPECIAL RECLAMATION 47 SCHOOL ST, STE 301 PHILIPPI WV26416 US	ENVIRONMENTAL PROTECTION OFFICE OF SPECIAL RECLAMATION 47 SCHOOL ST, STE 301 PHILIPPI WV 26416-9998 US

Line	Comm Ln Desc	Qty	Unit Issue	Unit Price	Total Price
19	Spillway Number Five	1.00000	LS	8,000	8,000

Comm Code	Manufacturer	Specification	Model #
77111603			

Extended Description :

Spillway Number Five

INVOICE TO	SHIP TO
ENVIRONMENTAL PROTECTION OFFICE OF SPECIAL RECLAMATION 47 SCHOOL ST, STE 301 PHILIPPI WV26416 US	ENVIRONMENTAL PROTECTION OFFICE OF SPECIAL RECLAMATION 47 SCHOOL ST, STE 301 PHILIPPI WV 26416-9998 US

Line	Comm Ln Desc	Qty	Unit Issue	Unit Price	Total Price
20	Siphon Box	1.00000	LS	30,000	30,000

Comm Code	Manufacturer	Specification	Model #
77111603			

Extended Description :

Siphon Box

INVOICE TO		SHIP TO	
ENVIRONMENTAL PROTECTION OFFICE OF SPECIAL RECLAMATION 47 SCHOOL ST, STE 301 PHILIPPI WV26416 US		ENVIRONMENTAL PROTECTION OFFICE OF SPECIAL RECLAMATION 47 SCHOOL ST, STE 301 PHILIPPI WV 26416-9998 US	

Line	Comm Ln Desc	Qty	Unit Issue	Unit Price	Total Price
21	Distribution Box	1.00000	LS	14,850	14,850

Comm Code	Manufacturer	Specification	Model #
77111603			

Extended Description :
Distribution Box

INVOICE TO		SHIP TO	
ENVIRONMENTAL PROTECTION OFFICE OF SPECIAL RECLAMATION 47 SCHOOL ST, STE 301 PHILIPPI WV26416 US		ENVIRONMENTAL PROTECTION OFFICE OF SPECIAL RECLAMATION 47 SCHOOL ST, STE 301 PHILIPPI WV 26416-9998 US	

Line	Comm Ln Desc	Qty	Unit Issue	Unit Price	Total Price
22	8 inch SDR35 PVC Pipe	400.00000	LF	20	8,000

Comm Code	Manufacturer	Specification	Model #
77111603			

Extended Description :
8 inch SDR35 PVC Pipe

INVOICE TO		SHIP TO	
ENVIRONMENTAL PROTECTION OFFICE OF SPECIAL RECLAMATION 47 SCHOOL ST, STE 301 PHILIPPI WV26416 US		ENVIRONMENTAL PROTECTION OFFICE OF SPECIAL RECLAMATION 47 SCHOOL ST, STE 301 PHILIPPI WV 26416-9998 US	

Line	Comm Ln Desc	Qty	Unit Issue	Unit Price	Total Price
23	6 inch HDPE DR-17 Pipe	1900.00000	LF	20	38,000

Comm Code	Manufacturer	Specification	Model #
77111603			

Extended Description :
6 inch HDPE DR-17 Pipe

INVOICE TO	SHIP TO
ENVIRONMENTAL PROTECTION OFFICE OF SPECIAL RECLAMATION 47 SCHOOL ST, STE 301 PHILIPPI WV26416 US	ENVIRONMENTAL PROTECTION OFFICE OF SPECIAL RECLAMATION 47 SCHOOL ST, STE 301 PHILIPPI WV 26416-9998 US

Line	Comm Ln Desc	Qty	Unit Issue	Unit Price	Total Price
24	4 inch HDPE DR-17 Pipe	100.00000	LF	10	1,000

Comm Code	Manufacturer	Specification	Model #
77111603			

Extended Description :
4 inch HDPE DR-17 Pipe

INVOICE TO	SHIP TO
ENVIRONMENTAL PROTECTION OFFICE OF SPECIAL RECLAMATION 47 SCHOOL ST, STE 301 PHILIPPI WV26416 US	ENVIRONMENTAL PROTECTION OFFICE OF SPECIAL RECLAMATION 47 SCHOOL ST, STE 301 PHILIPPI WV 26416-9998 US

Line	Comm Ln Desc	Qty	Unit Issue	Unit Price	Total Price
25	Pipe Number One	70.00000	LF	45	3150

Comm Code	Manufacturer	Specification	Model #
77111603			

Extended Description :
Pipe Number One

INVOICE TO		SHIP TO	
ENVIRONMENTAL PROTECTION OFFICE OF SPECIAL RECLAMATION 47 SCHOOL ST, STE 301 PHILIPPI WV26416 US		ENVIRONMENTAL PROTECTION OFFICE OF SPECIAL RECLAMATION 47 SCHOOL ST, STE 301 PHILIPPI WV 26416-9998 US	

Line	Comm Ln Desc	Qty	Unit Issue	Unit Price	Total Price
26	Pipe Number Two	61.00000	LF	30	1,830

Comm Code	Manufacturer	Specification	Model #
77111603			

Extended Description :
Pipe Number Two

INVOICE TO		SHIP TO	
ENVIRONMENTAL PROTECTION OFFICE OF SPECIAL RECLAMATION 47 SCHOOL ST, STE 301 PHILIPPI WV26416 US		ENVIRONMENTAL PROTECTION OFFICE OF SPECIAL RECLAMATION 47 SCHOOL ST, STE 301 PHILIPPI WV 26416-9998 US	

Line	Comm Ln Desc	Qty	Unit Issue	Unit Price	Total Price
27	Weir	1.00000	LS	1,000	1,000

Comm Code	Manufacturer	Specification	Model #
77111603			

Extended Description :
Weir

INVOICE TO		SHIP TO	
ENVIRONMENTAL PROTECTION OFFICE OF SPECIAL RECLAMATION 47 SCHOOL ST, STE 301 PHILIPPI WV26416 US		ENVIRONMENTAL PROTECTION OFFICE OF SPECIAL RECLAMATION 47 SCHOOL ST, STE 301 PHILIPPI WV 26416-9998 US	

Line	Comm Ln Desc	Qty	Unit Issue	Unit Price	Total Price
28	Intake Support System	1.00000	LS	2,000	2,000

Comm Code	Manufacturer	Specification	Model #
77111603			

Extended Description :
Intake Support System

INVOICE TO		SHIP TO	
ENVIRONMENTAL PROTECTION OFFICE OF SPECIAL RECLAMATION 47 SCHOOL ST, STE 301 PHILIPPI WV26416 US		ENVIRONMENTAL PROTECTION OFFICE OF SPECIAL RECLAMATION 47 SCHOOL ST, STE 301 PHILIPPI WV 26416-9998 US	

Line	Comm Ln Desc	Qty	Unit Issue	Unit Price	Total Price
29	Unclassified Excavation	90000.00000	CY	2,75	247,500

Comm Code	Manufacturer	Specification	Model #
77111603			

Extended Description :
Unclassified Excavation

INVOICE TO		SHIP TO	
ENVIRONMENTAL PROTECTION OFFICE OF SPECIAL RECLAMATION 47 SCHOOL ST, STE 301 PHILIPPI WV26416 US		ENVIRONMENTAL PROTECTION OFFICE OF SPECIAL RECLAMATION 47 SCHOOL ST, STE 301 PHILIPPI WV 26416-9998 US	

Line	Comm Ln Desc	Qty	Unit Issue	Unit Price	Total Price
30	12 inch Subsurface Drain	500.00000	LF	10	5,000

Comm Code	Manufacturer	Specification	Model #
77111603			

Extended Description :
12 inch Subsurface Drain

INVOICE TO		SHIP TO	
ENVIRONMENTAL PROTECTION OFFICE OF SPECIAL RECLAMATION 47 SCHOOL ST, STE 301 PHILIPPI WV26416 US		ENVIRONMENTAL PROTECTION OFFICE OF SPECIAL RECLAMATION 47 SCHOOL ST, STE 301 PHILIPPI WV 26416-9998 US	

Line	Comm Ln Desc	Qty	Unit Issue	Unit Price	Total Price
31	Conveyance Pipe	50.00000	LF	5.1	250.1

Comm Code	Manufacturer	Specification	Model #
77111603			

Extended Description :
Conveyance Pipe

INVOICE TO		SHIP TO	
ENVIRONMENTAL PROTECTION OFFICE OF SPECIAL RECLAMATION 47 SCHOOL ST, STE 301 PHILIPPI WV26416 US		ENVIRONMENTAL PROTECTION OFFICE OF SPECIAL RECLAMATION 47 SCHOOL ST, STE 301 PHILIPPI WV 26416-9998 US	

Line	Comm Ln Desc	Qty	Unit Issue	Unit Price	Total Price
32	12 inch Inline Cleanout	5.00000	EA	400.1	2,000.1

Comm Code	Manufacturer	Specification	Model #
77111603			

Extended Description :
12 inch Inline Cleanout

TOTAL! \$ 720,000.1

DEP1500000021	Document Phase Draft	Document Description Addendum No. 03: Buffalo Coal Co., S-52-80, DEP16308 Reclam.	Page 15 of 15
----------------------	--------------------------------	--	--

ADDITIONAL TERMS AND CONDITIONS

See attached document(s) for additional Terms and Conditions

SOLICITATION NUMBER: DEP150000021

Addendum Number: 03

The purpose of this addendum is to modify the solicitation identified as ("Solicitation") to reflect the change(s) identified and described below.

Applicable Addendum Category:

- Modify bid opening date and time
- Modify specifications of product or service being sought
- Attachment of vendor questions and responses
- Attachment of pre-bid sign-in sheet
- Correction of error
- Other

Description of Modification to Solicitation:

This addendum is issued to provide additional revisions to plans and specifications.

The bid opening date is changed to December 30, 2014 at 1:30 PM, EST.

Additional Documentation: Documentation related to this Addendum (if any) has been included herewith as Attachment A and is specifically incorporated herein by reference.

Terms and Conditions:

1. All provisions of the Solicitation and other addenda not modified herein shall remain in full force and effect.
2. Vendor should acknowledge receipt of all addenda issued for this Solicitation by completing an Addendum Acknowledgment, a copy of which is included herewith. Failure to acknowledge addenda may result in bid disqualification. The addendum acknowledgement should be submitted with the bid to expedite document processing.

ATTACHMENT A

**Addendum #3 - Questions During Pre-Bid Conference
For DEP16308
BUFFALO COAL COMPANY, INC.
Permit S-52-80**

REVISION #1: Plans

Detail #17 on plans for the 6 inch HDPE sludge pipe currently indicates using 1.5 inch crusher run limestone for pipe bedding and surrounding the entire pipe. The revision is that the 1.5 inch crusher run limestone shall remain on the bottom 4 inches for leveling, but the remainder stone may be omitted, and onsite select backfill may be used around and above the pipe.

REVISION #2: Specifications

Section 6.0 Revegetation

Item 6.2.2 Limestone

The lime to be used will be an agricultural grade pulverized limestone containing a minimum of 75% total carbonates or calcium carbonate equivalent. Fineness will be such that no less than 70% will pass through a #100 sieve and 100% will pass through a #20 sieve.

ADDENDUM ACKNOWLEDGEMENT FORM
SOLICITATION NO.: DEP150000021

Instructions: Please acknowledge receipt of all addenda issued with this solicitation by completing this addendum acknowledgment form. Check the box next to each addendum received and sign below. Failure to acknowledge addenda may result in bid disqualification.

Acknowledgment: I hereby acknowledge receipt of the following addenda and have made the necessary revisions to my proposal, plans and/or specification, etc.

Addendum Numbers Received:

(Check the box next to each addendum received)

- | | |
|--|--|
| <input checked="" type="checkbox"/> Addendum No. 1 | <input type="checkbox"/> Addendum No. 6 |
| <input checked="" type="checkbox"/> Addendum No. 2 | <input type="checkbox"/> Addendum No. 7 |
| <input checked="" type="checkbox"/> Addendum No. 3 | <input type="checkbox"/> Addendum No. 8 |
| <input type="checkbox"/> Addendum No. 4 | <input type="checkbox"/> Addendum No. 9 |
| <input type="checkbox"/> Addendum No. 5 | <input type="checkbox"/> Addendum No. 10 |

I understand that failure to confirm the receipt of addenda may be cause for rejection of this bid. I further understand that any verbal representation made or assumed to be made during any oral discussion held between Vendor's representatives and any state personnel is not binding. Only the information issued in writing and added to the specifications by an official addendum is binding.

GREEN MOUNTAIN COMPANY
Company
 PRESIDENT
Authorized Signature
12/30/14
Date

NOTE: This addendum acknowledgement should be submitted with the bid to expedite document processing.

Revised 6/8/2012

CERTIFICATION AND SIGNATURE PAGE

By signing below, or submitting documentation through wvOASIS, I certify that I have reviewed this Solicitation in its entirety; understand the requirements, terms and conditions, and other information contained herein; that I am submitting this bid, offer or proposal for review and consideration; that I am authorized by the vendor to execute and submit this bid, offer, or proposal, or any documents related thereto on vendor's behalf; that I am authorized to bind the vendor in a contractual relationship; and that to the best of my knowledge, the vendor has properly registered with any State agency that may require registration.

GREEN MOUNTAIN COMPANY
(Company)

[Signature] PRESIDENT
(Authorized Signature) (Representative Name, Title)

304-925-0253 (F) 9230 12/09/14
(Phone Number) (Fax Number) (Date)

ADDITIONAL TERMS AND CONDITIONS (Construction Contracts Only)

1. **CONTRACTOR'S LICENSE:** West Virginia Code § 21-11-2 requires that all persons desiring to perform contracting work in this state be licensed. The West Virginia Contractors Licensing Board is empowered to issue the contractor's license. Applications for a contractor's license may be made by contacting the West Virginia Division of Labor. West Virginia Code § 21-11-11 requires any prospective Vendor to include the contractor's license number on its bid. Failure to include a contractor's license number on the bid shall result in Vendor's bid being disqualified. Vendors should include a contractor's license number in the space provided below.

Contractor's Name: GREEN MOUNTAIN COMPANY

Contractor's License No. WV 002057

The apparent successful Vendor must furnish a copy of its contractor's license prior to the issuance of a Award Document.

2. **DRUG-FREE WORKPLACE AFFIDAVIT:** W. Va. Code § 21-1D-5 provides that any solicitation for a public improvement contract requires each Vendor that submits a bid for the work to submit at the same time an affidavit that the Vendor has a written plan for a drug-free workplace policy. To comply with this law, Vendor must either complete the enclosed drug-free workplace affidavit and submit the same with its bid or complete a similar affidavit that fulfills all of the requirements of the applicable code. Failure to submit the signed and notarized drug-free workplace affidavit or a similar affidavit that fully complies with the requirements of the applicable code, with the bid shall result in disqualification of Vendor's bid. Pursuant to W. Va. Code 21-1D-2(b) and (k), this provision does not apply to public improvement contracts the value of which is \$100,000 or less or temporary or emergency repairs.

2.1. **DRUG-FREE WORKPLACE POLICY:** Pursuant to W. Va. Code § 21-1D-4, Vendor and its subcontractors must implement and maintain a written drug-free workplace policy that complies with said article. The awarding public authority shall cancel this contract if: (1) Vendor fails to implement and maintain a written drug-free workplace policy described in the preceding paragraph, (2) Vendor fails to provide information regarding implementation of its drug-free workplace policy at the request of the public authority; or (3) Vendor provides to the public authority false information regarding the contractor's drug-free workplace policy. Pursuant to W. Va. Code 21-1D-2(b) and (k), this provision does not apply to public improvement contracts the value of which is \$100,000 or less or temporary or emergency repairs.

3. **DRUG FREE WORKPLACE REPORT:** Pursuant to W. Va. Code § 21-1D-7b, no less than once per year, or upon completion of the project, every contractor shall provide a certified report to the public authority which let the contract. For contracts over \$25,000, the

For the purposes of this section, the cost is the value of the steel product as delivered to the project; or

- d. The Director of the Purchasing Division determines that specified steel materials are not produced in the United States in sufficient quantity or otherwise are not reasonably available to meet contract requirements.

43. PREFERENCE FOR USE OF DOMESTIC ALUMINUM, GLASS, AND STEEL: In Accordance with W. Va. Code § 5-19-1 et seq., and W. Va. CSR § 148-10-1 et seq., for every contract or subcontract, subject to the limitations contained herein, for the construction, reconstruction, alteration, repair, improvement or maintenance of public works or for the purchase of any item of machinery or equipment to be used at sites of public works, only domestic aluminum, glass or steel products shall be supplied unless the spending officer determines, in writing, after the receipt of offers or bids, (1) that the cost of domestic aluminum, glass or steel products is unreasonable or inconsistent with the public interest of the State of West Virginia, (2) that domestic aluminum, glass or steel products are not produced in sufficient quantities to meet the contract requirements, or (3) the available domestic aluminum, glass, or steel do not meet the contract specifications. This provision only applies to public works contracts awarded in an amount more than fifty thousand dollars (\$50,000) or public works contracts that require more than ten thousand pounds of steel products.

The cost of domestic aluminum, glass, or steel products may be unreasonable if the cost is more than twenty percent (20%) of the bid or offered price for foreign made aluminum, glass, or steel products. If the domestic aluminum, glass or steel products to be supplied or produced in a "substantial labor surplus area", as defined by the United States Department of Labor, the cost of domestic aluminum, glass, or steel products may be unreasonable if the cost is more than thirty percent (30%) of the bid or offered price for foreign made aluminum, glass, or steel products.

This preference shall be applied to an item of machinery or equipment, as indicated above, when the item is a single unit of equipment or machinery manufactured primarily of aluminum, glass or steel, is part of a public works contract and has the sole purpose or of being a permanent part of a single public works project. This provision does not apply to equipment or machinery purchased by a spending unit for use by that spending unit and not as part of a single public works project.

All bids and offers including domestic aluminum, glass or steel products that exceed bid or offer prices including foreign aluminum, glass or steel products after application of the preferences provided in this provision may be reduced to a price equal to or lower than the lowest bid or offer price for foreign aluminum, glass or steel products plus the applicable preference. If the reduced bid or offer prices are made in writing and supersede the prior bid or offer prices, all bids or offers, including the reduced bid or offer prices, will be reevaluated in accordance with this rule.

BID BOND

KNOW ALL MEN BY THESE PRESENTS, That we, the undersigned, Green Mountain Company
of 511 50th Street, Charleston WV 25304, as Principal, and Ohio Farmers Insurance Company
of One Park Circle Westfield Center OH, a corporation organized and existing under the laws of the State of Ohio
with its principal office in the City of Westfield Center, as Surety, are held and firmly bound unto the State
of West Virginia, as Obligee, in the penal sum of Five Percent (\$ 5%) for the payment of which,
well and truly to be made, we jointly and severally bind ourselves, our heirs, administrators, executors, successors and assigns.

The Condition of the above obligation is such that whereas the Principal has submitted to the Purchasing Section of the
Department of Administration a certain bid or proposal, attached hereto and made a part hereof, to enter into a contract in writing for
DEP150000021 (DEP16308), Buffalo Coal Company in Grant County
according to plans and specifications.

NOW THEREFORE,

- (a) If said bid shall be rejected, or
- (b) If said bid shall be accepted and the Principal shall enter into a contract in accordance with the bid or proposal attached
hereto and shall furnish any other bonds and insurance required by the bid or proposal, and shall in all other respects perform the
agreement created by the acceptance of said bid, then this obligation shall be null and void, otherwise this obligation shall remain in full
force and effect. It is expressly understood and agreed that the liability of the Surety for any and all claims hereunder shall, in no event,
exceed the penal amount of this obligation as herein stated.

The Surety, for the value received, hereby stipulates and agrees that the obligations of said Surety and its bond shall be in no
way impaired or affected by any extension of the time within which the Obligee may accept such bid, and said Surety does hereby
waive notice of any such extension.

IN WITNESS WHEREOF, Principal and Surety have hereunto set their hands and seals, and such of them as are corporations
have caused their corporate seals to be affixed hereunto and these presents to be signed by their proper officers, this
14th day of November, 2014.

Principal Corporate Seal

Green Mountain Company
(Name of Principal)

By [Signature]
Rodney W. Clay (Must be President or
Vice President)

President
(Title)

Surety Corporate Seal

Ohio Farmers Insurance Company
(Name of Surety)

[Signature]
Sheila D. McCormick
Attorney-in-Fact

IMPORTANT – Surety executing bonds must be licensed in West Virginia to transact surety insurance. Corporate seals must be affixed,
and a power of attorney must be attached.

General
Power
of Attorney

POWER NO. 4751892 01

**Westfield Insurance Co.
Westfield National Insurance Co.
Ohio Farmers Insurance Co.**
Westfield Center, Ohio

CERTIFIED COPY

Know All Men by These Presents, That WESTFIELD INSURANCE COMPANY, WESTFIELD NATIONAL INSURANCE COMPANY and OHIO FARMERS INSURANCE COMPANY, corporations, hereinafter referred to individually as a "Company" and collectively as "Companies," duly organized and existing under the laws of the State of Ohio, and having its principal office in Westfield Center, Medina County, Ohio, do by these presents make, constitute and appoint

ROSS E. JOHNSON, H. RANDOLPH NEVILLE, PATRICK B. KEE, SHEILA D. MCCORMICK, JOINTLY OR SEVERALLY

of CHARLESTON and State of WV its true and lawful Attorney(s)-in-Fact, with full power and authority hereby conferred in its name, place and stead, to execute, acknowledge and deliver any and all bonds, recognizances, undertakings, or other instruments or contracts of suretyship-

LIMITATION: THIS POWER OF ATTORNEY CANNOT BE USED TO EXECUTE NOTE GUARANTEE, MORTGAGE DEFICIENCY, MORTGAGE GUARANTEE, OR BANK DEPOSITORY BONDS.

and to bind any of the Companies thereby as fully and to the same extent as if such bonds were signed by the President, sealed with the corporate seal of the applicable Company and duly attested by its Secretary, hereby ratifying and confirming all that the said Attorney(s)-in-Fact may do in the premises. Said appointment is made under and by authority of the following resolution adopted by the Board of Directors of each of the WESTFIELD INSURANCE COMPANY, WESTFIELD NATIONAL INSURANCE COMPANY and OHIO FARMERS INSURANCE COMPANY:

"Be It Resolved, that the President, any Senior Executive, any Secretary or any Fidelity & Surety Operations Executive or other Executive shall be and is hereby vested with full power and authority to appoint any one or more suitable persons as Attorney(s)-in-Fact to represent and act for and on behalf of the Company subject to the following provisions:

The Attorney-in-Fact, may be given full power and authority for and in the name of and on behalf of the Company, to execute, acknowledge and deliver, any and all bonds, recognizances, contracts, agreements of indemnity and other conditional or obligatory undertakings and any and all notices and documents canceling or terminating the Company's liability thereunder, and any such instruments so executed by any such Attorney-in-Fact shall be as binding upon the Company as if signed by the President and sealed and attested by the Corporate Secretary."

"Be It Further Resolved, that the signature of any such designated person and the seal of the Company heretofore or hereafter affixed to any power of attorney or any certificate relating thereto by facsimile, and any power of attorney or certificate bearing facsimile signatures or facsimile seal shall be valid and binding upon the Company with respect to any bond or undertaking to which it is attached." (Each adopted at a meeting held on February 8, 2000).

In Witness Whereof, WESTFIELD INSURANCE COMPANY, WESTFIELD NATIONAL INSURANCE COMPANY and OHIO FARMERS INSURANCE COMPANY have caused these presents to be signed by their National Surety Leader and Senior Executive and their corporate seals to be hereto affixed this 21st day of MARCH A.D., 2014 .

Corporate
Seals
Affixed



WESTFIELD INSURANCE COMPANY
WESTFIELD NATIONAL INSURANCE COMPANY
OHIO FARMERS INSURANCE COMPANY

By: *Dennis P. Baus*
Dennis P. Baus, National Surety Leader and Senior Executive

State of Ohio
County of Medina ss.:

On this 21st day of MARCH A.D., 2014 , before me personally came Dennis P. Baus to me known, who, being by me duly sworn, did depose and say, that he resides in Wooster, Ohio; that he is National Surety Leader and Senior Executive of WESTFIELD INSURANCE COMPANY, WESTFIELD NATIONAL INSURANCE COMPANY and OHIO FARMERS INSURANCE COMPANY, the companies described in and which executed the above instrument; that he knows the seals of said Companies; that the seals affixed to said instrument are such corporate seals; that they were so affixed by order of the Boards of Directors of said Companies; and that he signed his name thereto by like order.

Notarial
Seal
Affixed



David A. Kotnik

David A. Kotnik, Attorney at Law, Notary Public
My Commission Does Not Expire (Sec. 147.03 Ohio Revised Code)

State of Ohio
County of Medina ss.:

I, Frank A. Carrino, Secretary of WESTFIELD INSURANCE COMPANY, WESTFIELD NATIONAL INSURANCE COMPANY and OHIO FARMERS INSURANCE COMPANY, do hereby certify that the above and foregoing is a true and correct copy of a Power of Attorney, executed by said Companies, which is still in full force and effect; and furthermore, the resolutions of the Boards of Directors, set out in the Power of Attorney are in full force and effect.

In Witness Whereof, I have hereunto set my hand and affixed the seals of said Companies at Westfield Center, Ohio, this 14th day of November A.D., 2014 .



Frank A. Carrino Secretary
Frank A. Carrino, Secretary

Instructions for Completing AML Contractor Form OMB #1029-0119¹

Part A: General Information. Part A should be completed by the AML Contractor.

Part B: Legal Structure. Part B should be completed by the AML Contractor.

Part C: Certifying and updating information in the Applicant/Violator System (AVS). Part C should be completed by the AML Contractor, selecting the statement that best describes their situation.

If information is accurate, complete and up-to-date, then check the first statement and sign and date. Attach the Entity OFT printout to the OMB #1029-0119 form and submit the form and attachment to the AML Contracting Officer your business is working with.²

Upon reviewing an Entity OFT printout, if you discover the information contained in AVS is not accurate, complete and up-to-date, then check the second statement and complete Part D to provide missing or corrected information that needs reflected in AVS. Attach the Entity OFT printout to the OMB #1029-0119 form and submit the form and attachment to the AML Contracting Officer your business is working with.

If your business does not appear to have any information in AVS, then check the third statement and complete Part D. Submit the OMB #1029-0119 form to the AML Contracting Officer your business is working with.

Part D:

If current Entity OFT information for your business is incomplete, incorrect, or if you believe there is no information currently in the AVS for your business, you must complete Part D. Submit the OMB #1029-0119 form to the AML Contracting Officer your business is working with.

¹ If you need any assistance completing OMB #1029-0119, please contact the AVS Office at 800.643.9748.

² You may obtain your business' Entity OFT for certification purposes two ways. One way is to contact the AVS Office at 800.643.9748 and request the information. The second way is to access the AVS from your personal computer by visiting <https://avss.osmre.gov>. Click "Access AVS", and then Login as Guest. Place your cursor on the "Entity" Module and "Click". Type your business name in search box and press enter key. If more than one entity record appears, select your company and then "Click" on the "relationship" tab to display your Entity OFT information. Print the Entity OFT from AVS.

NOTES:

- THE FILTER FABRIC SHALL BE OVERLAPPED 1.0 FOOT, MINIMUM, AT ALL JOINTS.

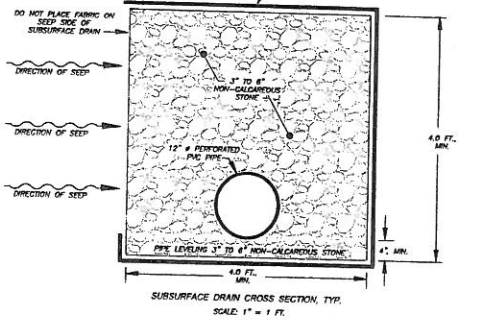

**DETAIL 21
SUBSURFACE DRAIN DETAILS**
SCALE: AS NOTED

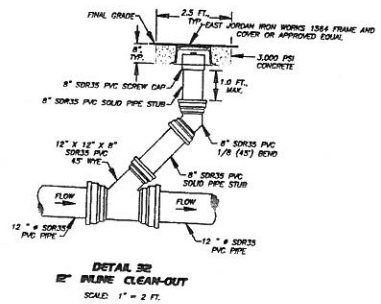
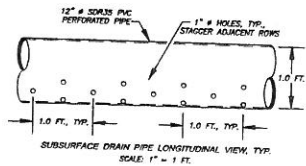
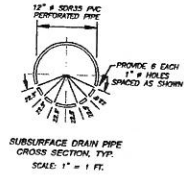

**DETAIL 22
PIPE CLEAN-OUT**
SCALE: 1\"/>

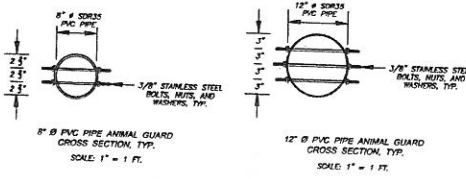

**DETAIL 23
ANIMAL GUARD DETAILS**
SCALE: AS NOTED

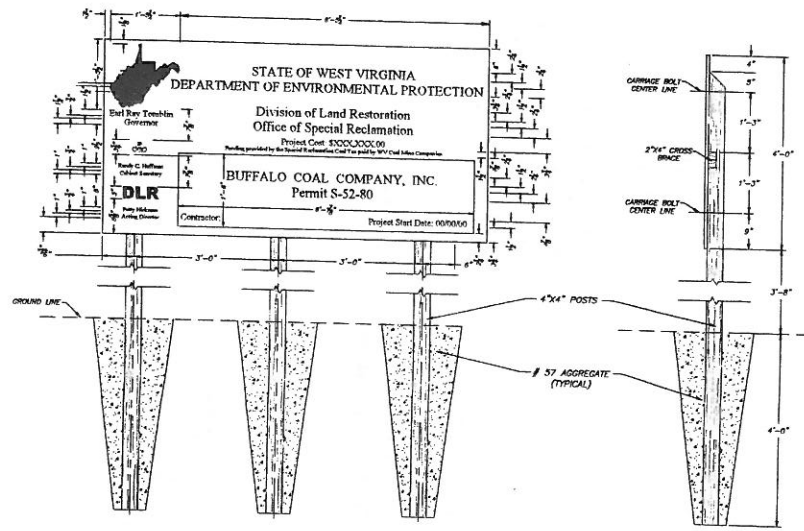

**DETAIL 24
PROJECT SIGN**
NOT TO SCALE

Copyright © (2013) Civil & Environmental Services, Inc.

C&E
Civil & Environmental Consultants, Inc.
80 Cambridge Place • Bridgeport, WV 26330
PA: 304.933.2119 • 855.468.9539 • Fax: 304.933.3387
www.cacinc.com

PROJECT NO. 130-497
DESIGNED BY: RMC
DRAWN BY: APD
CHECKED BY: RMC
APPROVED BY: GSL

west virginia
dep West Virginia Department of Environmental Protection
Office of Special Reclamation

REVISIONS	
DATE:	BY:
4/13/2014	rmc
4/22/2014	rmc

BUFFALO COAL COMPANY, INC
Permit Number S-52-80
P.O. No. DEPI6308
NEAR MT. STORM LAKE, UNION DISTRICT,
GRANT COUNTY, WEST VIRGINIA

MISCELLANEOUS DETAILS
SHEET 3

SCALE: AS SHOWN DATE: MARCH 2014

33
33

Part D.

Contractor's Business Name: GREEN MOUNTAIN COMPANY

If the current Entity OFT information for your business is incomplete or incorrect in AVS, or if there is no information in AVS for your business, you must provide all of the following information as it applies to your business. Please make as many copies of this page as you require.

- Every officer (President, Vice President, Secretary, Treasurer, etc.);
- All Directors;
- All persons performing a function similar to a Director;
- Every person or business that owns 10% or more of the voting stock in your business;
- Every partner, if your business is a partnership;
- Every member and manager, if your business is a limited liability company; and
- Any other person(s) who has the ability to determine the manner in which the AML reclamation project is being conducted.

Name	_____	Position/Title	_____
Address	_____	Telephone #	_____
Begin Date:	_____	% of Ownership	_____
		Ending Date:	_____
Name	_____	Position/Title	_____
Address	_____	Telephone #	_____
Begin Date:	_____	% of Ownership	_____
		Ending Date:	_____
Name	_____	Position/Title	_____
Address	_____	Telephone #	_____
Begin Date:	_____	% of Ownership	_____
		Ending Date:	_____
Name	_____	Position/Title	_____
Address	_____	Telephone #	_____
Begin Date:	_____	% of Ownership	_____
		Ending Date:	_____

PAPERWORK REDUCTION STATEMENT

The Paperwork Reduction Act of 1995 (44 U.S.C. 3501) requires us to inform you that: Federal Agencies may not conduct or sponsor, and a person is not required to respond to, a collection of information unless it displays a currently valid OMB control number. This information is necessary for all successful bidders prior to the distribution of AML funds, and is required to obtain a benefit.

Public reporting burden for this form is estimated to range from 15 minutes to 1 hour, with an average of 22 minutes per response, including time for reviewing instructions, gathering and maintaining data, and completing and reviewing the form. You may direct comments regarding the burden estimate or any other aspect of this form to the Information Collection Clearance Officer, Office of Surface Mining Reclamation and Enforcement, Room 202 SIB, Constitution Ave., NW, Washington, D.C. 20240.

AML CONTRACTOR INFORMATION FORM

You must complete this form for your AML contracting officer to request an eligibility evaluation from the Office of Surface Mining to determine if you are eligible to receive an AML contract. This requirement applies to contractors and their sub-contractors and is found under OSM's regulations at 30 CFR 874.16. When possible, please type your information onto this form to reduce errors on our end. NOTE: Signature and date this form is signed must be recent (within the last month) to be considered for a current bid

Part A: General Information

Business Name: Green Mountain Company Tax Payer ID No.: 55-0580174
Address: 511 50th Street
City: Charleston State: WV Zip Code: 25304 Phone: (304)925-0253
Fax No.: (304)925-9230 E-mail address: gmtk16@aol.com

Part B: Legal Structure

Corporation Sole Proprietorship Partnership LLC
 Other (please specify) _____

Part C: Certifying and updating information in the Applicant/Violator System (AVS). Select only one of the following options, follow the instructions for that option, and sign below.

I, Rodney W. Clay, have the express authority to certify that:
(print name)

- Information on the **attached** Entity Organizational Family Tree (OFT) from AVS is accurate, complete, and up-to-date. If you select this option, you **must** attach an Entity OFT from AVS to this form. Sign and date below and do not complete Part D.
- Part of the information on the **attached** Entity OFT from AVS is missing or incorrect and must be updated. If you select this option, you **must** attach an Entity OFT from AVS to this form. Use Part D to provide the missing or corrected information. Sign and date below and complete Part D.
- Our business currently is not listed in AVS. If you select this option, you must provide all information required in Part D. Sign and date below and complete Part D.

12/09/14
Date

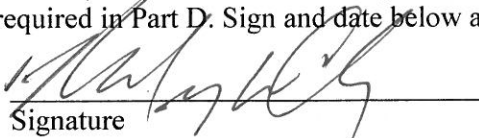
Signature

President
Title

IMPORTANT! In order to certify in Part C to the accuracy of existing information in AVS, you must obtain a copy of your business' Entity OFT. To obtain an Entity OFT, contact the AVS Office, toll-free, at 800-643-9748 or from the AVS website at <https://avss.osmre.gov>.



AVS OFT Report - 5/23/2013 9:33:04 AM

All OFT's where the selected entity is listed as an entity or related entity

Entity Selected (139758) Green Mountain Company

Parent Entity

- (139758) Green Mountain Company
- (139758) Green Mountain Company
- (139758) Green Mountain Company
- (139758) Green Mountain Company
- (139758) Green Mountain Company
- (139758) Green Mountain Company
- (139758) Green Mountain Company

Description	ExtDesc	Related Entity	% Ownership	Begin Date	End Date
Vice President		(139754) David H Bowman		3/1/1993	
Chairman of the Board		(139752) Rodney W Clay		12/1/1988	
Director		(139752) Rodney W Clay		12/1/1988	
President		(139752) Rodney W Clay		12/1/1985	
Shareholder		(139752) Rodney W Clay	100%	12/1/1985	
Treasurer		(139752) Rodney W Clay		12/1/1988	
Secretary		(139753) Tammy J Clay		4/1/1987	

PRESIDENT

STATE OF WEST VIRGINIA
Purchasing Division
PURCHASING AFFIDAVIT

MANDATE: Under W. Va. Code §5A-3-10a, no contract or renewal of any contract may be awarded by the state or any of its political subdivisions to any vendor or prospective vendor when the vendor or prospective vendor or a related party to the vendor or prospective vendor is a debtor and: (1) the debt owed is an amount greater than one thousand dollars in the aggregate; or (2) the debtor is in employer default.

EXCEPTION: The prohibition listed above does not apply where a vendor has contested any tax administered pursuant to chapter eleven of the W. Va. Code, workers' compensation premium, permit fee or environmental fee or assessment and the matter has not become final or where the vendor has entered into a payment plan or agreement and the vendor is not in default of any of the provisions of such plan or agreement.

DEFINITIONS:

"Debt" means any assessment, premium, penalty, fine, tax or other amount of money owed to the state or any of its political subdivisions because of a judgment, fine, permit violation, license assessment, defaulted workers' compensation premium, penalty or other assessment presently delinquent or due and required to be paid to the state or any of its political subdivisions, including any interest or additional penalties accrued thereon.

"Employer default" means having an outstanding balance or liability to the old fund or to the uninsured employers' fund or being in policy default, as defined in W. Va. Code § 23-2c-2, failure to maintain mandatory workers' compensation coverage, or failure to fully meet its obligations as a workers' compensation self-insured employer. An employer is not in employer default if it has entered into a repayment agreement with the Insurance Commissioner and remains in compliance with the obligations under the repayment agreement.

"Related party" means a party, whether an individual, corporation, partnership, association, limited liability company or any other form or business association or other entity whatsoever, related to any vendor by blood, marriage, ownership or contract through which the party has a relationship of ownership or other interest with the vendor so that the party will actually or by effect receive or control a portion of the benefit, profit or other consideration from performance of a vendor contract with the party receiving an amount that meets or exceeds five percent of the total contract amount.

AFFIRMATION: By signing this form, the vendor's authorized signer affirms and acknowledges under penalty of law for false swearing (W. Va. Code §61-5-3) that neither vendor nor any related party owe a debt as defined above and that neither vendor nor any related party are in employer default as defined above, unless the debt or employer default is permitted under the exception above.

WITNESS THE FOLLOWING SIGNATURE:

Vendor's Name: Green Mountain Company

Authorized Signature: [Signature], President

Date: 12/09/14

State of West Virginia

County of Kanawha, to-wit:

Taken, subscribed, and sworn to before me this 09th day of December, 2014,

My Commission expires April 06th, 2019.

AFFIX SEAL HERE

NOTARY PUBLIC

[Signature]

Purchasing Affidavit (Revised 07/01/2012)

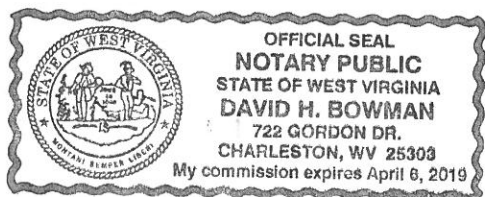

State of West Virginia
Purchasing Division

CERTIFIED DRUG-FREE WORKPLACE REPORT COVERSHEET

In accordance with **West Virginia Code § 21-1D-7b**, no less than once per year, or upon completion of the project, every contractor shall provide a certified report to the public authority which let the contract. That report must include each of the items identified below in the Required Report Content section.

Instructions: Vendor should complete this coversheet, attach it to the required report, and submit it to the appropriate location as follows: For contracts more than \$25,000, the report should be mailed to the West Virginia Purchasing Division at 2019 Washington Street East, Charleston, WV 25305. For contracts of \$25,000 or less, the vendor should mail the report to the public authority issuing the contract.

Contract Identification:

Contract Number: _____

Contract Purpose: _____

Agency Requesting Work: _____

Required Report Content: The attached report must include each of the items listed below. The vendor should check each box as an indication that the required information has been included in the attached report.

- Information indicating the education and training service to the requirements of **West Virginia Code § 21-1D-5** was provided;
- Name of the laboratory certified by the United States Department of Health and Human Services or its successor that performs the drug tests;
- Average number of employees in connection with the construction on the public improvement;
- Drug test results for the following categories including the number of positive tests and the number of negative tests: (A) Pre-employment and new hires; (B) Reasonable suspicion; (C) Post-accident; and (D) Random.

Vendor Contact Information:

Vendor Name: GREEN MOUNTAIN COMPANY Vendor Telephone: 304-925-0253
Vendor Address: 511 50th ST Vendor Fax: 304-925-9230
CHARLESTON WV
25304



State of West Virginia
DRUG FREE WORKPLACE CONFORMANCE AFFIDAVIT
West Virginia Code §21-1D-5

STATE OF WEST VIRGINIA,
COUNTY OF KANAWHA , TO-WIT:

I, Rodney W. Clay , after being first duly sworn, depose and state as follows:

- 1. I am an employee of GREEN MOUNTAIN COMPANY ; and,
(Company Name)
- 2. I do hereby attest that GREEN MOUNTAIN COMPANY
(Company Name)

maintains a valid written drug free workplace policy and that such policy is in compliance with **West Virginia Code §21-1D**.

The above statements are sworn to under the penalty of perjury.

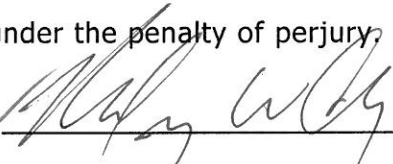
By: 
 Title: PRESIDENT
 Company Name: GREEN MOUNTAIN COMPANY
 Date: 12/09/14

Taken, subscribed and sworn to before me this 09th day of December, 2014.

~~By Commission expires April 06, 2019~~

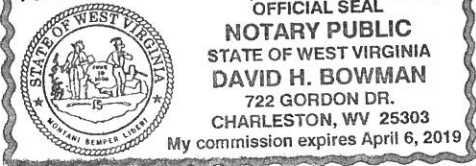

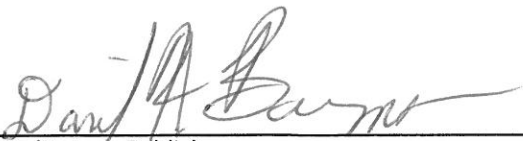
 (Notary Public)

THIS AFFIDAVIT MUST BE SUBMITTED WITH THE BID IN ORDER TO COMPLY WITH WV CODE PROVISIONS. FAILURE TO INCLUDE THE AFFIDAVIT WITH THE BID SHALL RESULT IN DISQUALIFICATION OF THE BID.

SOLICITATION NUMBER: DEP150000021
Addendum Number: 02

The purpose of this addendum is to modify the solicitation identified as ("Solicitation") to reflect the change(s) identified and described below.

Applicable Addendum Category:

- | Modify bid opening date and time
- | Modify specifications of product or service being sought
- | Attachment of vendor questions and responses
- | Attachment of pre-bid sign-in sheet
- | Correction of error
- | Other

Description of Modification to Solicitation:

This addendum is issued for the following reasons:

1. To provide a copy of the mandatory pre bid sign-in sheet.
2. To provide answers to vendor submitted questions.
3. To provide a revised bid schedule and commodity lines.

Additional Documentation: Documentation related to this Addendum (if any) has been included herewith as Attachment A and is specifically incorporated herein by reference.

Terms and Conditions:

1. All provisions of the Solicitation and other addenda not modified herein shall remain in full force and effect.
2. Vendor should acknowledge receipt of all addenda issued for this Solicitation by completing an Addendum Acknowledgment, a copy of which is included herewith. Failure to acknowledge addenda may result in bid disqualification. The addendum acknowledgement should be submitted with the bid to expedite document processing.

ATTACHMENT A

**Addendum #2- Questions During Pre-Bid Conference
For DEP16308
BUFFALO COAL COMPANY, INC.
Permit S-52-80**

The following questions were identified at the Pre-Bid Conference (PBC) conducted on-site on October 30, 2014. The answers and clarifications provided herein take precedence over verbal answers at the PBC and previously provided specifications and descriptions provided in the Solicitation should there be any conflicts between the two.

Note 1: Grout keys are being added to spillways 1, 2 and 3.

Note 2: The length of Pipe 2 is being changed to 61 feet long from 56 feet long. This has been revised on the Bid Schedule.

Note 3: The landowner, Dominion Power, for the bonded access road requires all gates to be closed and locked when not passing traffic, or to have an attendant if left open. A set of keys will be provided to the contractor for his/her use.

Note 4: Excavation of Pond One is specified as included in the lump sum price bid for **Item 4.1 "Site Preparation"**. As such any cross section lines that cross Pond One used to calculate final excavation quantities will be paid for excavation from the final water level of 3395.5 and up as everything below the water elevation has been paid under Item 4.1 "Site Preparation". In addition, should a highwall or solid rock be encountered while excavating the eastern portions of Pond One, the solid rock does not have to be drilled and shot. The Contractor shall make every effort to excavate the pond as specified and can only abandon the effort with the approval of the Engineer. Should solid rock be encountered and remain, the 15" diameter heavy duty PE pipe intake line and associated support system to the Siphon Box shall be modified. The modification will involve moving the intake support system to ensure the perforated portion of the 15" diameter heavy duty PE pipe will be suspended in the deepest portions of the pond with any portion of the 15" diameter heavy duty PE pipe lying on the pond bottom being installed with solid pipe.

Q1: What is the Engineer's estimate?

A1: \$1.16 million.

Q2: Can "SmartDitch" be used in lieu of grouted rip-rap ditches?

A2: No, per preliminary calculations, Ditches One, Two and Four carry flows too large for 24 inch Trapezoidal SmartDitch substitutions. Ditch Three might be a candidate for a SmartDitch substitution, but we want all ditches to be constructed consistently. In addition, one of the primary goals of the project is to add alkalinity to the watershed which can only be accomplished by using limestone riprap.

Q3: The contract calls for a soil cover of 12 inches for vegetation. Is there enough topsoil for the total area to be reclaimed?

19

**Addendum #2- Questions During Pre-Bid Conference
For DEP16308
BUFFALO COAL COMPANY, INC.
Permit S-52-80**

- A3: No. There are a topsoil pile and an ash pile near the top of the permit that is to be used in the reclamation process. The contract calls for a lime rate of 12 tons per acre to be incorporated into the upper six inches of the final grade material to counteract the acidity of the material on site and aid in vegetation establishment. Please see Specification 8.0, Unclassified Excavation, for further information.
- Q4: Large rocks and boulders seem to be apparent on the site. The specifications call for no material to be larger than 24 inches in any dimension to be used in the backfill. Are these rocks and boulders to be broken up?
- A4: In accordance with Specification Paragraph 8.5.3.3, boulders incorporated into the fill are not to be larger than 24 inches in any dimension.
- Q5: The specifications call for one foot thick layers for the fill material, but the fill material contains two feet thick material. Please clarify.
- A5: The allowable fill layer thickness will be revised to two feet thick. Specification 8.5.3.5 should now read "Excavated material shall be placed in embankments in successive layers not to exceed two foot (2') in thickness before compaction. The layers shall be constructed approximately horizontal. Each layer, before starting the next, shall be leveled and smoothed by means of power driven graders, dozers, or other suitable equipment with adequate weight, capacity, and power to do the work. Layers shall be extended across the entire fill at the level of deposition unless otherwise authorized by the Owner. Each layer, before starting the next, shall be compacted".
- Q6: How much ash is available on site?
- A6: There is an old ash pile stockpile from Baseline Station 9+65, 75 feet right to Baseline Station 10+70, 105 feet left. This is to be used as a soil amendment in accordance with Specification Paragraph 8.5.3.11.3. The amount has not been calculated but it is not substantial.
- Q7: Can the rock on site be used for ditches?
- A7: No, it is acidic in nature, which would contribute to the existing AMD problem.

REVISIONS

REVISED BID SCHEDULE

The BID SCHEDULE has been revised for Item #7.15. A new schedule has been included and labeled "Revised".

REVISED SPECIFICATIONS

20

**Addendum #2 - Questions During Pre-Bid Conference
For DEP16308
BUFFALO COAL COMPANY, INC.
Permit S-52-80**

Project Sign specifications have been added.

1.1 PROJECT SIGN

The work to be performed under this Section consists of providing all labor, material and equipment necessary to install a project sign as indicated on the detail included herein and as specified herein.

2.0 MATERIALS

Paint. Paint for the project sign shall be one (1) coat Exterior-Grade Wood Primer-Sealer, and two (2) coats Exterior-Grade Enamel by Glidden or equivalent.

Wood. Sign face shall be 3/4" X 4' X 8' Marine Exterior plywood, and posts and cross braces shall be treated.

Hardware. All hardware shall be manufactured from good, commercial-quality material and be rust resistant such as galvanized coated.

3.0 EXECUTION

Project Sign. The signboard shall be cut to the dimensions shown on the details herein. The sign shall be painted with one (1) coat of primer and two (2) coats of white enamel. All exterior cut edges shall be smooth sanded prior to painting. All edges shall be double primed. The letters, border and strips shall be painted as shown on the detail drawing.

The Contractor shall bolt the sign to posts and provide required cross bracing. The posts and sign shall be erected and posts set in gravel base, as shown on the drawings. One (1) sign is required and is to be located at the direction of WVDEP.

Specification 8.5.3.5 has been changed to read:

8.5.3.5 Excavated material shall be placed in embankments in successive layers not to exceed two foot (2') in thickness before compaction. The layers shall be constructed approximately horizontal. Each layer, before starting the next, shall be leveled and smoothed by means of power driven graders, dozers, or other suitable equipment with adequate weight, capacity, and power to do the work. Layers shall be extended across the entire fill at the level of deposition unless otherwise authorized by the Owner. Each layer, before starting the next, shall be compacted

REQUEST FOR QUOTATION NO. DEP16308
(15*21)

SIGN IN SHEET
PLEASE PRINT

Page 1 of 3
Date: October 30, 2014

* PLEASE BE SURE TO PRINT LEGIBLY - IF POSSIBLE, LEAVE A BUSINESS CARD

FIRM & REPRESENTATIVE NAME	MAILING ADDRESS	TELEPHONE & FAX NUMBERS
Company: <u>GREEN MOUNTAIN COMPANY</u> Rep: <u>DAVID H. BOWMAN</u> Email Address: <u>DHB722@yahoo.com</u>	<u>511 50th ST</u> <u>Charleston WV</u> <u>25304</u>	PHONE <u>304-925-0258</u> TOLL FREE FAX <u>304-925-9230</u>
Company: <u>McCourt & Son Const.</u> Rep: <u>GARY LONG</u> Email Address: <u>glong@wirefire.com</u>	<u>5802 Centralia Rd</u> <u>Sutton WV 26601</u>	PHONE <u>304 765-5288</u> TOLL FREE FAX <u>304 765-5293</u>
Company: <u>J F ALLEN CO</u> Rep: <u>JAMES ALLEN</u> Email Address: <u>JAMES.ALLEN@JFALLENCO.COM</u>	<u>PO Box 2079</u> <u>Buckhannon WV</u> <u>26201</u>	PHONE <u>304/472 8890</u> TOLL FREE FAX <u>304/472 8887</u>
Company: <u>Pineville Paving & Excavating Inc.</u> Rep: <u>Tony Bradford</u> Email Address: <u>tony@ppi@aol.com</u>	<u>P.O. Box 1290</u> <u>Pineville WV 24874</u>	PHONE <u>304-732-8303</u> TOLL FREE FAX <u>304-732-7855</u>
Company: <u>Collins Building & Contracting Inc.</u> Rep: <u>Roger Collins</u> Email Address: <u>Collins building @ Hughes.net</u>	<u>3406 Carling Rd</u> <u>Flintwood, WV</u> <u>26421</u>	PHONE <u>304-765-3521</u> TOLL FREE FAX

REQUEST FOR QUOTATION NO. DEP16308
 (15+21)

SIGN IN SHEET

PLEASE PRINT

Page 2 of 3
 Date: October 30, 2014

* PLEASE BE SURE TO PRINT LEGIBLY - IF POSSIBLE, LEAVE A BUSINESS CARD

FIRM & REPRESENTATIVE NAME	MAILING ADDRESS	TELEPHONE & FAX NUMBERS
Company: <u>CIVIL & ENVIRONMENTAL CONSULTANTS</u>	<u>90 CAMBRIDGE PLACE</u>	PHONE <u>304-333-3119</u>
Rep: <u>RADY CALKINS</u>	<u>DROGERSPORT, WV</u>	TOLL FREE
Email Address: <u>RCALKINS@CECALK.COM</u>		FAX
Company: <u>Mountaineer Infrastructure</u>	<u>2336 LOUISVILLE RD</u>	PHONE <u>304-866-4953</u>
Rep: <u>John Summerhill</u>	<u>Dry Fork</u>	TOLL FREE
Email Address: <u>JHEVANS@11105.COM</u>		FAX <u>304-866-4329</u>
Company: <u>A.L.L. CONSTRUCTION INC.</u>	<u>P.O. Box 232</u>	PHONE <u>304 693-7131</u>
Rep: <u>STEVE SZABO</u>	<u>Mr. Storm, WV</u>	TOLL FREE
Email Address: <u>all.estimator@saunter.com</u>		FAX <u>304 693-7199</u>
Company: <u>JOE WILLIAMS</u>	<u>P8801 CR22A</u>	PHONE <u>304-614-8887</u>
Rep: <u>WILLIAMS EXCAVATING</u>	<u>Bloomington, OH</u>	TOLL FREE
Email Address: _____		FAX
Company: <u>Williams Excavating</u>	<u>89 Wagon LN</u>	PHONE <u>740 937 2077</u>
Rep: <u>TODD Bishop</u>	<u>Kingwood WV</u>	TOLL FREE
Email Address: <u>tbishop@williamsx.com</u>	<u>26537</u>	FAX

REQUEST FOR QUOTATION NO. DEP16308
(15#21)

SIGN IN SHEET

PLEASE PRINT

Page 3 of 3

Date: October 30, 2014

* PLEASE BE SURE TO PRINT LEGIBLY - IF POSSIBLE, LEAVE A BUSINESS CARD

FIRM & REPRESENTATIVE NAME	MAILING ADDRESS	TELEPHONE & FAX NUMBERS
Company: <u>EASTERN Arrow</u>	<u>PO BOX 4108</u>	PHONE <u>304-44-0255</u>
Rep: <u>Ann WARDWELL</u>	<u>CHARLESTON WV</u>	TOLL FREE
Email Address: <u>easternarrow@hotmail.com</u>	<u>25364</u>	FAX
Company: <u>RBS</u>	<u>PO BOX 198</u>	PHONE <u>304-497-3800</u>
Rep: <u>JK ROSE</u>	<u>MAXWELTON, WV 24957</u>	TOLL FREE
Email Address: <u>UNIDN CONCRETE@FRONTIER.NET</u>		FAX <u>304-497-3802</u>
Company: <u>ASPEN CORPORATION</u>	<u>2400 ZITTER DR</u>	PHONE <u>304-763-4573</u>
Rep: <u>BRIAN KNIGHT</u>	<u>DANIELS WV 25832</u>	TOLL FREE
Email Address: <u>BKNIGHT@ASPEN-506.COM</u>		FAX <u>304-763-4591</u>
Company: <u>RLD construction</u>	<u>11665 Box 274</u>	PHONE <u>1304 227 4468</u>
Rep: <u>Jed Mullenex</u>	<u>Marman WV 26270</u>	TOLL FREE <u>1304 642 4818</u>
Email Address:		FAX
Company: <u>Breakaway Inc.</u>	<u>1539 Old Turnpike Rd</u>	PHONE <u>765-5317</u>
Rep: <u>Doug Vincent</u>	<u>Sutton WV 26601</u>	TOLL FREE
Email Address: <u>doug@breakawaywv.com</u>		FAX <u>765-5389</u>

END

David McCoy WVDEP

ADDENDUM ACKNOWLEDGEMENT FORM
SOLICITATION NO.: DEP1500000021

Instructions: Please acknowledge receipt of all addenda issued with this solicitation by completing this addendum acknowledgment form. Check the box next to each addendum received and sign below. Failure to acknowledge addenda may result in bid disqualification.

Acknowledgment: I hereby acknowledge receipt of the following addenda and have made the necessary revisions to my proposal, plans and/or specification, etc.

Addendum Numbers Received:

(Check the box next to each addendum received)

- | | |
|--|--|
| <input checked="" type="checkbox"/> Addendum No. 1 | <input type="checkbox"/> Addendum No. 6 |
| <input checked="" type="checkbox"/> Addendum No. 2 | <input type="checkbox"/> Addendum No. 7 |
| <input checked="" type="checkbox"/> Addendum No. 3 | <input type="checkbox"/> Addendum No. 8 |
| <input type="checkbox"/> Addendum No. 4 | <input type="checkbox"/> Addendum No. 9 |
| <input type="checkbox"/> Addendum No. 5 | <input type="checkbox"/> Addendum No. 10 |

I understand that failure to confirm the receipt of addenda may be cause for rejection of this bid. I further understand that any verbal representation made or assumed to be made during any oral discussion held between Vendor's representatives and any state personnel is not binding. Only the information issued in writing and added to the specifications by an official addendum is binding.

GREEN MOUNTAIN COMPANY
Company

[Signature] PRESIDENT
Authorized Signature

12/30/14
Date

NOTE: This addendum acknowledgement should be submitted with the bid to expedite document processing.
Revised 6/8/2012

BUFFALO COAL COMPANY, INC. – Permit Number S-52-80

Green Mountain Co. **REVISED- BID SCHEDULE**
 511 50th Street
 Charleston, WV 25304 **DEP 16308**

Company Name: _____

Address: _____

The DEP reserves the right to request additional information and supporting documentation regarding Unit Prices, when the Unit Price appears to be unreasonable.

ITEM NO.	QUANTITY		DESCRIPTION	UNIT PRICE	AMOUNT
1.0	Lump Sum		Mobilization and Demobilization (Cannot be more than 10% of TOTAL AMOUNT BID for the Project)	\$10,000	\$10,000
2.0	Lump Sum		Construction Layout Stakes (Cannot be more than 5% of TOTAL AMOUNT BID for the Project)	\$5,000	\$5,000
3.0	Lump Sum		Quality Control (Cannot be more than 5% of TOTAL AMOUNT BID for the Project)	\$5,000	\$5,000
4.1	Lump Sum		Site Preparation (Cannot be more than 10% of TOTAL AMOUNT BID for the Project)	\$33,920	\$33,920
4.2	500	TN	Incidental Stone	\$40	\$20,000
4.3	2800	LF	Fence	\$12	\$33,600
4.4	6	EA	Farm Gate	\$1,100	\$6,600
4.5	1,000	LF	Access Road Number One	\$16	\$16,000
5.1	6,200	LF	Straw Wattles	\$1	\$6,200
5.2	2,100	LF	Silt Fence	\$1	\$2,100
6.0	41	AC	Revegetation (Plan View)	\$1,000	\$41,000
7.1	800	LF	2.0 Ft. Deep "Vee" Shaped Grouted Riprap Ditch	\$45	\$36,000
7.2	1,550	LF	2.5 Ft. Deep "Vee" Shaped Grouted Riprap Ditch	\$50	\$77,500
7.3	500	LF	3.0 Ft. Deep "Vee" Shaped Grouted Riprap Ditch	\$105	\$52,500
7.4	Lump Sum		Spillway Number One	\$3,000	\$3,000
7.5	Lump Sum		Spillway Number Two	\$3,000	\$3,000
7.6	Lump Sum		Spillway Number Three	\$3,000	\$3,000
7.7	Lump Sum		Spillway Number Four	\$3,000	\$3,000
7.8	Lump Sum		Spillway Number Five	\$8,000	\$8,000
7.9	Lump Sum		Siphon Box	\$30,000	\$30,000
7.10	Lump Sum		Distribution Box	\$14,850	\$14,850
7.11	400	LF	8" SDR35 PVC Pipe	\$20	\$8,000
7.12	1,900	LF	6" HDPE DR-17 Pipe	\$20	\$38,000
7.13	100	LF	4" HDPE DR-17 Pipe	\$10	\$1,000
7.14	70	LF	Pipe Number One	\$45	\$3,150
7.15	61	LF	Pipe Number Two	\$30	\$1,830
7.16	Lump Sum		Weir	\$1,000	\$1,000
7.17	Lump Sum		Intake Support System	\$2,000	\$2,000
8.0	90,000	CY	Unclassified Excavation	\$275	\$24,750
10.1	500	LF	12" Subsurface Drain	\$10	\$5,000
10.2	50	LF	Conveyance Pipe	\$5	\$250
10.3	5	EA	12" Inline Cleanout	\$400	\$2,000
TOTAL:				\$720,000	

Bidders Authorized Signature: _____

Date: 12/30/14

SOLICITATION NUMBER: CRFQ DEP150000021

Addendum Number: 01

The purpose of this addendum is to modify the solicitation identified as ("Solicitation") to reflect the change(s) identified and described below.

Applicable Addendum Category:

- | Modify bid opening date and time
- | Modify specifications of product or service being sought
- | Attachment of vendor questions and responses
- | Attachment of pre-bid sign-in sheet
- | Correction of error
- | Other

Description of Modification to Solicitation:

This addendum is issued to modify the bid opening date.

The bid opening date will be changed to December 9, 2014 at 1:30 PM, EST.

Additional Documentation: Documentation related to this Addendum (if any) has been included herewith as Attachment A and is specifically incorporated herein by reference.

Terms and Conditions:

1. All provisions of the Solicitation and other addenda not modified herein shall remain in full force and effect.
2. Vendor should acknowledge receipt of all addenda issued for this Solicitation by completing an Addendum Acknowledgment, a copy of which is included herewith. Failure to acknowledge addenda may result in bid disqualification. The addendum acknowledgement should be submitted with the bid to expedite document processing.

ADDENDUM ACKNOWLEDGEMENT FORM
SOLICITATION NO.: DEP150000021

Instructions: Please acknowledge receipt of all addenda issued with this solicitation by completing this addendum acknowledgment form. Check the box next to each addendum received and sign below. Failure to acknowledge addenda may result in bid disqualification.

Acknowledgment: I hereby acknowledge receipt of the following addenda and have made the necessary revisions to my proposal, plans and/or specification, etc.

Addendum Numbers Received:

(Check the box next to each addendum received)

- | | |
|--|--|
| <input checked="" type="checkbox"/> Addendum No. 1 | <input type="checkbox"/> Addendum No. 6 |
| <input checked="" type="checkbox"/> Addendum No. 2 | <input type="checkbox"/> Addendum No. 7 |
| <input checked="" type="checkbox"/> Addendum No. 3 | <input type="checkbox"/> Addendum No. 8 |
| <input type="checkbox"/> Addendum No. 4 | <input type="checkbox"/> Addendum No. 9 |
| <input type="checkbox"/> Addendum No. 5 | <input type="checkbox"/> Addendum No. 10 |

I understand that failure to confirm the receipt of addenda may be cause for rejection of this bid. I further understand that any verbal representation made or assumed to be made during any oral discussion held between Vendor's representatives and any state personnel is not binding. Only the information issued in writing and added to the specifications by an official addendum is binding.

GREEN MOUNTAIN COMPANY
Company
[Signature] PRESIDENT
Authorized Signature
12/09/14
Date

NOTE: This addendum acknowledgment should be submitted with the bid to expedite document processing.
Revised 6/8/2012

BUFFALO COAL COMPANY, INC. – Permit Number S-52-80
-REVISED- BID SCHEDULE *Green Mountain Company*
DEP 16308 511 50th Street
 Charleston, WV 25304

Company Name: _____
 Address: _____

The DEP reserves the right to request additional information and supporting documentation regarding Unit Prices, when the Unit Price appears to be unreasonable.

ITEM NO.	QUANTITY	DESCRIPTION	UNIT PRICE	AMOUNT
1.0	Lump Sum	Mobilization and Demobilization (Cannot be more than 10% of TOTAL AMOUNT BID for the Project)	\$	\$
2.0	Lump Sum	Construction Layout Stakes (Cannot be more than 5% of TOTAL AMOUNT BID for the Project)	\$	\$
3.0	Lump Sum	Quality Control (Cannot be more than 5% of TOTAL AMOUNT BID for the Project)	\$	\$
4.1	Lump Sum	Site Preparation (Cannot be more than 10% of TOTAL AMOUNT BID for the Project)	\$	\$
4.2	500 TN	Incidental Stone	\$	\$
4.3	2800 LF	Fence	\$	\$
4.4	6 EA	Farm Gate	\$	\$
4.5	1,000 LF	Access Road Number One	\$	\$
5.1	6,200 LF	Straw Wattles	\$	\$
5.2	2,100 LF	Silt Fence	\$	\$
6.0	41 AC	Revegetation (Plan View)	\$	\$
7.1	800 LF	2.0 Ft. Deep "Vee" Shaped Grouted Riprap Ditch	\$	\$
7.2	1,550 LF	2.5 Ft. Deep "Vee" Shaped Grouted Riprap Ditch	\$	\$
7.3	500 LF	3.0 Ft. Deep "Vee" Shaped Grouted Riprap Ditch	\$	\$
7.4	Lump Sum	Spillway Number One	\$	\$
7.5	Lump Sum	Spillway Number Two	\$	\$
7.6	Lump Sum	Spillway Number Three	\$	\$
7.7	Lump Sum	Spillway Number Four	\$	\$
7.8	Lump Sum	Spillway Number Five	\$	\$
7.9	Lump Sum	Siphon Box	\$	\$
7.10	Lump Sum	Distribution Box	\$	\$
7.11	400 LF	8" SDR35 PVC Pipe	\$	\$
7.12	1,900 LF	6" HDPE DR-17 Pipe	\$	\$
7.13	100 LF	4" HDPE DR-17 Pipe	\$	\$
7.14	70 LF	Pipe Number One	\$	\$
7.15	61 LF	Pipe Number Two	\$	\$
7.16	Lump Sum	Weir	\$	\$
7.17	Lump Sum	Intake Support System	\$	\$
8.0	90,000 CY	Unclassified Excavation	\$	\$
10.1	500 LF	12" Subsurface Drain	\$	\$
10.2	50 LF	Conveyance Pipe	\$	\$
10.3	5 EA	12" Inline Cleanout	\$	\$
TOTAL:			\$	\$

Bidders Authorized Signature: *[Handwritten Signature]*

Date: 12/09/14

ADDENDUM ACKNOWLEDGEMENT FORM
SOLICITATION NO.: DEP150000021

Instructions: Please acknowledge receipt of all addenda issued with this solicitation by completing this addendum acknowledgment form. Check the box next to each addendum received and sign below. Failure to acknowledge addenda may result in bid disqualification.

Acknowledgment: I hereby acknowledge receipt of the following addenda and have made the necessary revisions to my proposal, plans and/or specification, etc.

Addendum Numbers Received:
(Check the box next to each addendum received)

- | | |
|--|--|
| <input checked="" type="checkbox"/> Addendum No. 1 | <input type="checkbox"/> Addendum No. 6 |
| <input checked="" type="checkbox"/> Addendum No. 2 | <input type="checkbox"/> Addendum No. 7 |
| <input checked="" type="checkbox"/> Addendum No. 3 | <input type="checkbox"/> Addendum No. 8 |
| <input type="checkbox"/> Addendum No. 4 | <input type="checkbox"/> Addendum No. 9 |
| <input type="checkbox"/> Addendum No. 5 | <input type="checkbox"/> Addendum No. 10 |

I understand that failure to confirm the receipt of addenda may be cause for rejection of this bid. I further understand that any verbal representation made or assumed to be made during any oral discussion held between Vendor's representatives and any state personnel is not binding. Only the information issued in writing and added to the specifications by an official addendum is binding.

GREEN MOUNTAIN COMPANY
Company
[Signature] PRESIDENT
Authorized Signature
12/09/14
Date

NOTE: This addendum acknowledgment should be submitted with the bid to expedite document processing.
Revised 6/8/2012