



State of West Virginia  
 Department of Administration  
 Purchasing Division  
 2019 Washington Street East  
 Post Office Box 50130  
 Charleston, WV 25305-0130

**Solicitation**

NUMBER
HOP14103

PAGE
1

ADDRESS CORRESPONDENCE TO ATTENTION OF:
ROBERTA WAGNER
304-558-0067

\*B22102807 304-562-0121

CIMCO INC  
 2336 VIRGINIA AVE

HURRICANE WV 25526

HEALTH AND HUMAN RESOURCES  
 HOPEMONT HOSPITAL  
 CENTRAL RECEIVING  
 150 HOPEMONT DRIVE  
 TERRA ALTA, WV  
 26764-7728 304-789-2411

VENDOR

SHIP TO

**RECEIVED**  
 NOV 12 2013

DATE PRINTED
11/07/2013

BID OPENING DATE: 12/11/2013 BID OPENING TIME 1:30PM

LINE	QUANTITY	UOP	CAT. NO.	ITEM NUMBER	UNIT PRICE	AMOUNT
0001	1	JB	936-75	THE WEST VIRGINIA PURCHASING DIVISION IS SOLICITING BIDS ON BEHALF OF THE WVDHHR/HOPEMONT HOSPITAL TO ESTABLISH A CONTRACT FOR THE ONE TIME PURCHASE OF REPLACEMENT OF (1) INTERMEDIATE CAST IRON SECTION #5 IN MIDDLE OF HB SMITH CAST IRON BOILER M/N 3500 LOCATED IN THE MORGAN HALL BUILDING AND REPLACE CONTROL PANEL WITH CONTROL SYTEM INTERNATIONAL MODEL # 7728 OR EQUAL IN BASEMENT OF UNIT BUILDING LOCATED AT HOPEMONT HOSPITAL PER THE ATTACHED SPECIFICATIONS AND INSTRUCTIONS TO BIDDERS.		\$45,858.00
				REPAIR TWO BOILERS AT HOPEMONT HOSPITAL AS FOLLOWS:  (1) REPLACE ONE INTERMEDIATE CAST IRON SECTION IN MIDDLE OF HB SMITH CAST IRON BOILER M/N 3500 LOCATED IN THE MORGAN HALL BUILDING. (2) REPLACE CONTROL PANEL FOR GAS FIRED BOILER SYSTEM WITH CONTROL SYSTEM INTERNATIONAL MODEL #7728 OR EQUAL, LOCATED IN THE BASEMENT OF THE UNITS BUILDING.		

RECEIVED  
 2013 DEC 11 AM 8:16  
 WV PURCHASING DIVISION

SIGNATURE <i>Jeff Hillman</i>	TELEPHONE 304-562-7205	DATE 12-11-13
TITLE Service Manager	FEIN 55-0749511	ADDRESS CHANGES TO BE NOTED ABOVE

WHEN RESPONDING TO SOLICITATION, INSERT NAME AND ADDRESS IN SPACE ABOVE LABELED 'VENDOR'

All Vendors should arrive prior to the starting time for the pre-bid. Vendors who arrive after the starting time but prior to the end of the pre-bid will be permitted to sign in, but are charged with knowing all matters discussed at the pre-bid.

Questions submitted at least five business days prior to a scheduled pre-bid will be discussed at the pre-bid meeting if possible. Any discussions or answers to questions at the pre-bid meeting are preliminary in nature and are non-binding. Official and binding answers to questions will be published in a written addendum to the Solicitation prior to bid opening.

4. **VENDOR QUESTION DEADLINE:** Vendors may submit questions relating to this Solicitation to the Purchasing Division. Questions must be submitted in writing. All questions must be submitted on or before the date listed below and to the address listed below in order to be considered. A written response will be published in a Solicitation addendum if a response is possible and appropriate. Non-written discussions, conversations, or questions and answers regarding this Solicitation are preliminary in nature and are non-binding.

Question Submission Deadline: November 22, 2013 - end of business

Submit Questions to: Roberta A. Wagner

2019 Washington Street, East

Charleston, WV 25305

Fax: 304-558-4115

Email: [roberta.a.wagner@wv.gov](mailto:roberta.a.wagner@wv.gov)

5. **VERBAL COMMUNICATION:** Any verbal communication between the Vendor and any State personnel is not binding, including that made at the mandatory pre-bid conference. Only information issued in writing and added to the Solicitation by an official written addendum by the Purchasing Division is binding.
6. **BID SUBMISSION:** All bids must be signed and delivered by the Vendor to the Purchasing Division at the address listed below on or before the date and time of the bid opening. Any bid received by the Purchasing Division staff is considered to be in the possession of the Purchasing Division and will not be returned for any reason. The bid delivery address is:

Department of Administration, Purchasing Division  
2019 Washington Street East  
Charleston, WV 25305-0130

The bid should contain the information listed below on the face of the envelope or the bid may not be considered:

**SEALED BID**

BUYER: \_\_\_\_\_  
 SOLICITATION NO.: \_\_\_\_\_  
 BID OPENING DATE: \_\_\_\_\_  
 BID OPENING TIME: \_\_\_\_\_  
 FAX NUMBER: \_\_\_\_\_

In the event that Vendor is responding to a request for proposal, the Vendor shall submit one original technical and one original cost proposal plus \_\_\_\_\_ convenience copies of each to the Purchasing Division at the address shown above. Additionally, the Vendor should identify the bid type as either a technical or cost proposal on the face of each bid envelope submitted in response to a request for proposal as follows:

BID TYPE:  Technical  
 Cost

7. **BID OPENING:** Bids submitted in response to this Solicitation will be opened at the location identified below on the date and time listed below. Delivery of a bid after the bid opening date and time will result in bid disqualification. For purposes of this Solicitation, a bid is considered delivered when time stamped by the official Purchasing Division time clock.

Bid Opening Date and Time: December 11, 2013 - Wednesday @ 1:30 P.M.

Bid Opening Location: Department of Administration, Purchasing Division  
 2019 Washington Street East  
 Charleston, WV 25305-0130

8. **ADDENDUM ACKNOWLEDGEMENT:** Changes or revisions to this Solicitation will be made by an official written addendum issued by the Purchasing Division. Vendor should acknowledge receipt of all addenda issued with this Solicitation by completing an Addendum Acknowledgment Form, a copy of which is included herewith. Failure to acknowledge addenda may result in bid disqualification. The addendum acknowledgement should be submitted with the bid to expedite document processing.
9. **BID FORMATTING:** Vendor should type or electronically enter the information onto its bid to prevent errors in the evaluation. Failure to type or electronically enter the information may result in bid disqualification.

**GENERAL TERMS AND CONDITIONS:**

1. **CONTRACTUAL AGREEMENT:** Issuance of a Purchase Order signed by the Purchasing Division Director, or his designee, and approved as to form by the Attorney General's office constitutes acceptance of this Contract made by and between the State of West Virginia and the Vendor. Vendor's signature on its bid signifies Vendor's agreement to be bound by and accept the terms and conditions contained in this Contract.
  
2. **DEFINITIONS:** As used in this Solicitation/Contract, the following terms shall have the meanings attributed to them below. Additional definitions may be found in the specifications included with this Solicitation/Contract.
  - 2.1 **"Agency" or "Agencies"** means the agency, board, commission, or other entity of the State of West Virginia that is identified on the first page of the Solicitation or any other public entity seeking to procure goods or services under this Contract.
  
  - 2.2 **"Contract"** means the binding agreement that is entered into between the State and the Vendor to provide the goods and services requested in the Solicitation.
  
  - 2.3 **"Director"** means the Director of the West Virginia Department of Administration, Purchasing Division.
  
  - 2.4 **"Purchasing Division"** means the West Virginia Department of Administration, Purchasing Division.
  
  - 2.5 **"Purchase Order"** means the document signed by the Agency and the Purchasing Division, and approved as to form by the Attorney General, that identifies the Vendor as the successful bidder and Contract holder.
  
  - 2.6 **"Solicitation"** means the official solicitation published by the Purchasing Division and identified by number on the first page thereof.
  
  - 2.7 **"State"** means the State of West Virginia and/or any of its agencies, commissions, boards, etc. as context requires.
  
  - 2.8 **"Vendor" or "Vendors"** means any entity submitting a bid in response to the Solicitation, the entity that has been selected as the lowest responsible bidder, or the entity that has been awarded the Contract as context requires.

3. **CONTRACT TERM; RENEWAL; EXTENSION:** The term of this Contract shall be determined in accordance with the category that has been identified as applicable to this Contract below:

**Term Contract**

**Initial Contract Term:** This Contract becomes effective on

and extends for a period of \_\_\_\_\_ year(s).

**Renewal Term:** This Contract may be renewed upon the mutual written consent of the Agency, and the Vendor, with approval of the Purchasing Division and the Attorney General's office (Attorney General approval is as to form only). Any request for renewal must be submitted to the Purchasing Division Director thirty (30) days prior to the expiration date of the initial contract term or appropriate renewal term. A Contract renewal shall be in accordance with the terms and conditions of the original contract. Renewal of this Contract is limited to \_\_\_\_\_ successive one (1) year periods. Automatic renewal of this Contract is prohibited. Notwithstanding the foregoing, Purchasing Division approval is not required on agency delegated or exempt purchases. Attorney General approval may be required for vendor terms and conditions.

**Reasonable Time Extension:** At the sole discretion of the Purchasing Division Director, and with approval from the Attorney General's office (Attorney General approval is as to form only), this Contract may be extended for a reasonable time after the initial Contract term or after any renewal term as may be necessary to obtain a new contract or renew this Contract. Any reasonable time extension shall not exceed twelve (12) months. Vendor may avoid a reasonable time extension by providing the Purchasing Division Director with written notice of Vendor's desire to terminate this Contract 30 days prior to the expiration of the then current term. During any reasonable time extension period, the Vendor may terminate this Contract for any reason upon giving the Purchasing Division Director 30 days written notice. Automatic extension of this Contract is prohibited. Notwithstanding the foregoing, Purchasing Division approval is not required on agency delegated or exempt purchases, but Attorney General approval may be required.

**Release Order Limitations:** In the event that this contract permits release orders, a release order may only be issued during the time this Contract is in effect. Any release order issued within one year of the expiration of this Contract shall be effective for one year from the date the release order is issued. No release order may be extended beyond one year after this Contract has expired.

**Fixed Period Contract:** This Contract becomes effective upon Vendor's receipt of the notice to proceed and must be completed within \_\_\_\_\_ 45 calendar \_\_\_\_\_ days.

- One Time Purchase:** The term of this Contract shall run from the issuance of the Purchase Order until all of the goods contracted for have been delivered, but in no event shall this Contract extend for more than one fiscal year.
- Other:** See attached.
4. **NOTICE TO PROCEED:** Vendor shall begin performance of this Contract immediately upon receiving notice to proceed unless otherwise instructed by the Agency. Unless otherwise specified, the fully executed Purchase Order will be considered notice to proceed
5. **QUANTITIES:** The quantities required under this Contract shall be determined in accordance with the category that has been identified as applicable to this Contract below.
- Open End Contract:** Quantities listed in this Solicitation are approximations only, based on estimates supplied by the Agency. It is understood and agreed that the Contract shall cover the quantities actually ordered for delivery during the term of the Contract, whether more or less than the quantities shown.
- Service:** The scope of the service to be provided will be more clearly defined in the specifications included herewith.
- Combined Service and Goods:** The scope of the service and deliverable goods to be provided will be more clearly defined in the specifications included herewith.
- One Time Purchase:** This Contract is for the purchase of a set quantity of goods that are identified in the specifications included herewith. Once those items have been delivered, no additional goods may be procured under this Contract without an appropriate change order approved by the Vendor, Agency, Purchasing Division, and Attorney General's office.
6. **PRICING:** The pricing set forth herein is firm for the life of the Contract, unless specified elsewhere within this Solicitation/Contract by the State. A Vendor's inclusion of price adjustment provisions in its bid, without an express authorization from the State in the Solicitation to do so, may result in bid disqualification.
7. **EMERGENCY PURCHASES:** The Purchasing Division Director may authorize the Agency to purchase goods or services in the open market that Vendor would otherwise provide under this Contract if those goods or services are for immediate or expedited delivery in an emergency. Emergencies shall include, but are not limited to, delays in transportation or an unanticipated increase in the volume of work. An emergency purchase in the open market, approved by the Purchasing Division Director, shall not constitute of breach of this Contract and shall not entitle the Vendor to any form of compensation or damages. This provision does not excuse the State from fulfilling its obligations under a One Time Purchase contract.
8. **REQUIRED DOCUMENTS:** All of the items checked below must be provided to the Purchasing Division by the Vendor as specified below.

**BID BOND:** All Vendors shall furnish a bid bond in the amount of five percent (5%) of the total amount of the bid protecting the State of West Virginia. The bid bond must be submitted with the bid.

**PERFORMANCE BOND:** The apparent successful Vendor shall provide a performance bond in the amount of . The performance bond must be issued and received by the Purchasing Division prior to Contract award. On construction contracts, the performance bond must be 100% of the Contract value.

**LABOR/MATERIAL PAYMENT BOND:** The apparent successful Vendor shall provide a labor/material payment bond in the amount of 100% of the Contract value. The labor/material payment bond must be issued and delivered to the Purchasing Division prior to Contract award.

In lieu of the Bid Bond, Performance Bond, and Labor/Material Payment Bond, the Vendor may provide certified checks, cashier's checks, or irrevocable letters of credit. Any certified check, cashier's check, or irrevocable letter of credit provided in lieu of a bond must be of the same amount and delivered on the same schedule as the bond it replaces. A letter of credit submitted in lieu of a performance and labor/material payment bond will only be allowed for projects under \$100,000. Personal or business checks are not acceptable.

**MAINTENANCE BOND:** The apparent successful Vendor shall provide a two (2) year maintenance bond covering the roofing system. The maintenance bond must be issued and delivered to the Purchasing Division prior to Contract award.

**WORKERS' COMPENSATION INSURANCE:** The apparent successful Vendor shall have appropriate workers' compensation insurance and shall provide proof thereof upon request.

**INSURANCE:** The apparent successful Vendor shall furnish proof of the following insurance prior to Contract award and shall list the state as a certificate holder:

**Commercial General Liability Insurance:**  
\$ 1,000,000.00 or more.

**Builders Risk Insurance:** builders risk – all risk insurance in an amount equal to 100% of the amount of the Contract.

The apparent successful Vendor shall also furnish proof of any additional insurance requirements contained in the specifications prior to Contract award regardless of whether or not that insurance requirement is listed above.

**LICENSE(S) / CERTIFICATIONS / PERMITS:** In addition to anything required under the Section entitled Licensing, of the General Terms and Conditions, the apparent successful Vendor shall furnish proof of the following licenses, certifications, and/or permits prior to Contract award, in a form acceptable to the Purchasing Division.

- General Contractor's License
- Master License (HVAC/Plumber)
- 
- 

The apparent successful Vendor shall also furnish proof of any additional licenses or certifications contained in the specifications prior to Contract award regardless of whether or not that requirement is listed above.

9. **LITIGATION BOND:** The Director reserves the right to require any Vendor that files a protest of an award to submit a litigation bond in the amount equal to one percent of the lowest bid submitted or \$5,000, whichever is greater. The entire amount of the bond shall be forfeited if the hearing officer determines that the protest was filed for frivolous or improper purpose, including but not limited to, the purpose of harassing, causing unnecessary delay, or needless expense for the Agency. All litigation bonds shall be made payable to the Purchasing Division. In lieu of a bond, the protester may submit a cashier's check or certified check payable to the Purchasing Division. Cashier's or certified checks will be deposited with and held by the State Treasurer's office. If it is determined that the protest has not been filed for frivolous or improper purpose, the bond or deposit shall be returned in its entirety.
10. **ALTERNATES:** Any model, brand, or specification listed herein establishes the acceptable level of quality only and is not intended to reflect a preference for, or in any way favor, a particular brand or vendor. Vendors may bid alternates to a listed model or brand provided that the alternate is at least equal to the model or brand and complies with the required specifications. The equality of any alternate being bid shall be determined by the State at its sole discretion. Any Vendor bidding an alternate model or brand should clearly identify the alternate items in its bid and should include manufacturer's specifications, industry literature, and/or any other relevant documentation demonstrating the equality of the alternate items. Failure to provide information for alternate items may be grounds for rejection of a Vendor's bid.
11. **EXCEPTIONS AND CLARIFICATIONS:** The Solicitation contains the specifications that shall form the basis of a contractual agreement. Vendor shall clearly mark any exceptions, clarifications, or



other proposed modifications in its bid. Exceptions to, clarifications of, or modifications of a requirement or term and condition of the Solicitation may result in bid disqualification.

- 12. LIQUIDATED DAMAGES:** Vendor shall pay liquidated damages in the amount  
for
- This clause shall in no way be considered exclusive and shall not limit the State or Agency's right to pursue any other available remedy.
- 13. ACCEPTANCE/REJECTION:** The State may accept or reject any bid in whole, or in part. Vendor's signature on its bid signifies acceptance of the terms and conditions contained in the Solicitation and Vendor agrees to be bound by the terms of the Contract, as reflected in the Purchase Order, upon receipt.
- 14. REGISTRATION:** Prior to Contract award, the apparent successful Vendor must be properly registered with the West Virginia Purchasing Division and must have paid the \$125 fee if applicable.
- 15. COMMUNICATION LIMITATIONS:** In accordance with West Virginia Code of State Rules §148-1-6.6, communication with the State of West Virginia or any of its employees regarding this Solicitation during the solicitation, bid, evaluation or award periods, except through the Purchasing Division, is strictly prohibited without prior Purchasing Division approval. Purchasing Division approval for such communication is implied for all agency delegated and exempt purchases.
- 16. FUNDING:** This Contract shall continue for the term stated herein, contingent upon funds being appropriated by the Legislature or otherwise being made available. In the event funds are not appropriated or otherwise made available, this Contract becomes void and of no effect beginning on July 1 of the fiscal year for which funding has not been appropriated or otherwise made available.
- 17. PAYMENT:** Payment in advance is prohibited under this Contract. Payment may only be made after the delivery and acceptance of goods or services. The Vendor shall submit invoices, in arrears, to the Agency at the address on the face of the purchase order labeled "Invoice To."
- 18. UNIT PRICE:** Unit prices shall prevail in cases of a discrepancy in the Vendor's bid.
- 19. DELIVERY:** All quotations are considered freight on board destination ("F.O.B. destination") unless alternate shipping terms are clearly identified in the bid. Vendor's listing of shipping terms that contradict the shipping terms expressly required by this Solicitation may result in bid disqualification.
- 20. INTEREST:** Interest attributable to late payment will only be permitted if authorized by the West Virginia Code. Presently, there is no provision in the law for interest on late payments.
- 21. PREFERENCE:** Vendor Preference may only be granted upon written request and only in accordance with the West Virginia Code § 5A-3-37 and the West Virginia Code of State Rules. A Resident Vendor Certification form has been attached hereto to allow Vendor to apply for the preference. Vendor's

failure to submit the Resident Vendor Certification form with its bid will result in denial of Vendor Preference. Vendor Preference does not apply to construction projects.

- 22. SMALL, WOMEN-OWNED, OR MINORITY-OWNED BUSINESSES:** For any solicitations publicly advertised for bid on or after July 1, 2012, in accordance with West Virginia Code §5A-3-37(a)(7) and W. Va. CSR § 148-22-9, any non-resident vendor certified as a small, women-owned, or minority-owned business under W. Va. CSR § 148-22-9 shall be provided the same preference made available to any resident vendor. Any non-resident small, women-owned, or minority-owned business must identify itself as such in writing, must submit that writing to the Purchasing Division with its bid, and must be properly certified under W. Va. CSR § 148-22-9 prior to submission of its bid to receive the preferences made available to resident vendors. Preference for a non-resident small, women-owned, or minority owned business shall be applied in accordance with W. Va. CSR § 148-22-9.
- 23. TAXES:** The Vendor shall pay any applicable sales, use, personal property or any other taxes arising out of this Contract and the transactions contemplated thereby. The State of West Virginia is exempt from federal and state taxes and will not pay or reimburse such taxes.
- 24. CANCELLATION:** The Purchasing Division Director reserves the right to cancel this Contract immediately upon written notice to the vendor if the materials or workmanship supplied do not conform to the specifications contained in the Contract. The Purchasing Division Director may cancel any purchase or Contract upon 30 days written notice to the Vendor in accordance with West Virginia Code of State Rules § 148-1-7.16.2.
- 25. WAIVER OF MINOR IRREGULARITIES:** The Director reserves the right to waive minor irregularities in bids or specifications in accordance with West Virginia Code of State Rules § 148-1-4.6.
- 26. TIME:** Time is of the essence with regard to all matters of time and performance in this Contract.
- 27. APPLICABLE LAW:** This Contract is governed by and interpreted under West Virginia law without giving effect to its choice of law principles. Any information provided in specification manuals, or any other source, verbal or written, which contradicts or violates the West Virginia Constitution, West Virginia Code or West Virginia Code of State Rules is void and of no effect.
- 28. COMPLIANCE:** Vendor shall comply with all applicable federal, state, and local laws, regulations and ordinances. By submitting a bid, Vendors acknowledge that they have reviewed, understand, and will comply with all applicable law.
- 29. PREVAILING WAGE:** On any contract for the construction of a public improvement, Vendor and any subcontractors utilized by Vendor shall pay a rate or rates of wages which shall not be less than the fair minimum rate or rates of wages (prevailing wage), as established by the West Virginia Division of Labor under West Virginia Code §§ 21-5A-1 et seq. and available at <http://www.sos.wv.gov/administrative-law/wagerates/Pages/default.aspx>. Vendor shall be responsible for ensuring compliance with prevailing wage requirements and determining when prevailing wage

requirements are applicable. The required contract provisions contained in West Virginia Code of State Rules § 42-7-3 are specifically incorporated herein by reference.

- 30. ARBITRATION:** Any references made to arbitration contained in this Contract, Vendor's bid, or in any American Institute of Architects documents pertaining to this Contract are hereby deleted, void, and of no effect.
- 31. MODIFICATIONS:** This writing is the parties' final expression of intent. Notwithstanding anything contained in this Contract to the contrary, no modification of this Contract shall be binding without mutual written consent of the Agency, and the Vendor, with approval of the Purchasing Division and the Attorney General's office (Attorney General approval is as to form only). **No Change shall be implemented by the Vendor until such time as the Vendor receives an approved written change order from the Purchasing Division.**
- 32. WAIVER:** The failure of either party to insist upon a strict performance of any of the terms or provision of this Contract, or to exercise any option, right, or remedy herein contained, shall not be construed as a waiver or a relinquishment for the future of such term, provision, option, right, or remedy, but the same shall continue in full force and effect. Any waiver must be expressly stated in writing and signed by the waiving party.
- 33. SUBSEQUENT FORMS:** The terms and conditions contained in this Contract shall supersede any and all subsequent terms and conditions which may appear on any form documents submitted by Vendor to the Agency or Purchasing Division such as price lists, order forms, invoices, sales agreements, or maintenance agreements, and includes internet websites or other electronic documents. Acceptance or use of Vendor's forms does not constitute acceptance of the terms and conditions contained thereon.
- 34. ASSIGNMENT:** Neither this Contract nor any monies due, or to become due hereunder, may be assigned by the Vendor without the express written consent of the Agency, the Purchasing Division, the Attorney General's office (as to form only), and any other government agency or office that may be required to approve such assignments. Notwithstanding the foregoing, Purchasing Division approval may or may not be required on certain agency delegated or exempt purchases.
- 35. WARRANTY:** The Vendor expressly warrants that the goods and/or services covered by this Contract will: (a) conform to the specifications, drawings, samples, or other description furnished or specified by the Agency; (b) be merchantable and fit for the purpose intended; and (c) be free from defect in material and workmanship.
- 36. STATE EMPLOYEES:** State employees are not permitted to utilize this Contract for personal use and the Vendor is prohibited from permitting or facilitating the same.
- 37. BANKRUPTCY:** In the event the Vendor files for bankruptcy protection, the State of West Virginia may deem this Contract null and void, and terminate this Contract without notice.

**38. [RESERVED]**

**39. CONFIDENTIALITY:** The Vendor agrees that it will not disclose to anyone, directly or indirectly, any such personally identifiable information or other confidential information gained from the Agency, unless the individual who is the subject of the information consents to the disclosure in writing or the disclosure is made pursuant to the Agency's policies, procedures, and rules. Vendor further agrees to comply with the Confidentiality Policies and Information Security Accountability Requirements, set forth in <http://www.state.wv.us/admin/purchase/privacy/default.html>.

**40. DISCLOSURE:** Vendor's response to the Solicitation and the resulting Contract are considered public documents and will be disclosed to the public in accordance with the laws, rules, and policies governing the West Virginia Purchasing Division. Those laws include, but are not limited to, the Freedom of Information Act found in West Virginia Code § 29B-1-1 et seq.

If a Vendor considers any part of its bid to be exempt from public disclosure, Vendor must so indicate by specifically identifying the exempt information, identifying the exemption that applies, providing a detailed justification for the exemption, segregating the exempt information from the general bid information, and submitting the exempt information as part of its bid but in a segregated and clearly identifiable format. Failure to comply with the foregoing requirements will result in public disclosure of the Vendor's bid without further notice. A Vendor's act of marking all or nearly all of its bid as exempt is not sufficient to avoid disclosure and WILL NOT BE HONORED. Vendor's act of marking a bid or any part thereof as "confidential" or "proprietary" is not sufficient to avoid disclosure and WILL NOT BE HONORED. In addition, a legend or other statement indicating that all or substantially all of the bid is exempt from disclosure is not sufficient to avoid disclosure and WILL NOT BE HONORED. Vendor will be required to defend any claimed exemption for nondisclosure in the event of an administrative or judicial challenge to the State's nondisclosure. Vendor must indemnify the State for any costs incurred related to any exemptions claimed by Vendor. Any questions regarding the applicability of the various public records laws should be addressed to your own legal counsel prior to bid submission.

**41. LICENSING:** In accordance with West Virginia Code of State Rules §148-1-6.1.7, Vendor must be licensed and in good standing in accordance with any and all state and local laws and requirements by any state or local agency of West Virginia, including, but not limited to, the West Virginia Secretary of State's Office, the West Virginia Tax Department, West Virginia Insurance Commission, or any other state agency or political subdivision. Upon request, the Vendor must provide all necessary releases to obtain information to enable the Purchasing Division Director or the Agency to verify that the Vendor is licensed and in good standing with the above entities.

**42. ANTITRUST:** In submitting a bid to, signing a contract with, or accepting a Purchase Order from any agency of the State of West Virginia, the Vendor agrees to convey, sell, assign, or transfer to the State of West Virginia all rights, title, and interest in and to all causes of action it may now or hereafter acquire under the antitrust laws of the United States and the State of West Virginia for price fixing and/or unreasonable restraints of trade relating to the particular commodities or services purchased or acquired

by the State of West Virginia. Such assignment shall be made and become effective at the time the purchasing agency tenders the initial payment to Vendor.

- 43. VENDOR CERTIFICATIONS:** By signing its bid or entering into this Contract, Vendor certifies (1) that its bid was made without prior understanding, agreement, or connection with any corporation, firm, limited liability company, partnership, person or entity submitting a bid for the same material, supplies, equipment or services; (2) that its bid is in all respects fair and without collusion or fraud; (3) that this Contract is accepted or entered into without any prior understanding, agreement, or connection to any other entity that could be considered a violation of law; and (4) that it has reviewed this RFQ in its entirety; understands the requirements, terms and conditions, and other information contained herein. Vendor's signature on its bid also affirms that neither it nor its representatives have any interest, nor shall acquire any interest, direct or indirect, which would compromise the performance of its services hereunder. Any such interests shall be promptly presented in detail to the Agency.

The individual signing this bid on behalf of Vendor certifies that he or she is authorized by the Vendor to execute this bid or any documents related thereto on Vendor's behalf; that he or she is authorized to bind the Vendor in a contractual relationship; and that, to the best of his or her knowledge, the Vendor has properly registered with any State agency that may require registration.

- 44. PURCHASING CARD ACCEPTANCE:** The State of West Virginia currently utilizes a Purchasing Card program, administered under contract by a banking institution, to process payment for goods and services. The Vendor must accept the State of West Virginia's Purchasing Card for payment of all orders under this Contract unless the box below is checked.

Vendor is not required to accept the State of West Virginia's Purchasing Card as payment for all goods and services.

- 45. VENDOR RELATIONSHIP:** The relationship of the Vendor to the State shall be that of an independent contractor and no principal-agent relationship or employer-employee relationship is contemplated or created by this Contract. The Vendor as an independent contractor is solely liable for the acts and omissions of its employees and agents. Vendor shall be responsible for selecting, supervising, and compensating any and all individuals employed pursuant to the terms of this Solicitation and resulting contract. Neither the Vendor, nor any employees or subcontractors of the Vendor, shall be deemed to be employees of the State for any purpose whatsoever. Vendor shall be exclusively responsible for payment of employees and contractors for all wages and salaries, taxes, withholding payments, penalties, fees, fringe benefits, professional liability insurance premiums, contributions to insurance and pension, or other deferred compensation plans, including but not limited to, Workers' Compensation and Social Security obligations, licensing fees, *etc.* and the filing of all necessary documents, forms and returns pertinent to all of the foregoing. Vendor shall hold harmless the State, and shall provide the State and Agency with a defense against any and all claims including, but not limited to, the foregoing payments, withholdings, contributions, taxes, Social Security taxes, and employer income tax returns.

- 46. INDEMNIFICATION:** The Vendor agrees to indemnify, defend, and hold harmless the State and the Agency, their officers, and employees from and against: (1) Any claims or losses for services rendered

by any subcontractor, person, or firm performing or supplying services, materials, or supplies in connection with the performance of the Contract; (2) Any claims or losses resulting to any person or entity injured or damaged by the Vendor, its officers, employees, or subcontractors by the publication, translation, reproduction, delivery, performance, use, or disposition of any data used under the Contract in a manner not authorized by the Contract, or by Federal or State statutes or regulations; and (3) Any failure of the Vendor, its officers, employees, or subcontractors to observe State and Federal laws including, but not limited to, labor and wage and hour laws.

- 47. PURCHASING AFFIDAVIT:** In accordance with West Virginia Code § 5A-3-10a, all Vendors are required to sign, notarize, and submit the Purchasing Affidavit stating that neither the Vendor nor a related party owe a debt to the State in excess of \$1,000. The affidavit must be submitted prior to award, but should be submitted with the Vendor's bid. A copy of the Purchasing Affidavit is included herewith.
- 48. ADDITIONAL AGENCY AND LOCAL GOVERNMENT USE:** This Contract may be utilized by and extends to other agencies, spending units, and political subdivisions of the State of West Virginia; county, municipal, and other local government bodies; and school districts ("Other Government Entities"). This Contract shall be extended to the aforementioned Other Government Entities on the same prices, terms, and conditions as those offered and agreed to in this Contract. If the Vendor does not wish to extend the prices, terms, and conditions of its bid and subsequent contract to the Other Government Entities, the Vendor must clearly indicate such refusal in its bid. A refusal to extend this Contract to the Other Government Entities shall not impact or influence the award of this Contract in any manner.
- 49. CONFLICT OF INTEREST:** Vendor, its officers or members or employees, shall not presently have or acquire any interest, direct or indirect, which would conflict with or compromise the performance of its obligations hereunder. Vendor shall periodically inquire of its officers, members and employees to ensure that a conflict of interest does not arise. Any conflict of interest discovered shall be promptly presented in detail to the Agency.
- 50. REPORTS:** Vendor shall provide the Agency and/or the Purchasing Division with the following reports identified by a checked box below:
- Such reports as the Agency and/or the Purchasing Division may request. Requested reports may include, but are not limited to, quantities purchased, agencies utilizing the contract, total contract expenditures by agency, etc.
  - Quarterly reports detailing the total quantity of purchases in units and dollars, along with a listing of purchases by agency. Quarterly reports should be delivered to the Purchasing Division via email at [purchasing.requisitions@wv.gov](mailto:purchasing.requisitions@wv.gov).
- 51. BACKGROUND CHECK:** In accordance with W. Va. Code § 15-2D-3, the Director of the Division of Protective Services shall require any service provider whose employees are regularly employed on the grounds or in the buildings of the Capitol complex or who have access to sensitive or critical information

to submit to a fingerprint-based state and federal background inquiry through the state repository. The service provider is responsible for any costs associated with the fingerprint-based state and federal background inquiry.

After the contract for such services has been approved, but before any such employees are permitted to be on the grounds or in the buildings of the Capitol complex or have access to sensitive or critical information, the service provider shall submit a list of all persons who will be physically present and working at the Capitol complex to the Director of the Division of Protective Services for purposes of verifying compliance with this provision.

The State reserves the right to prohibit a service provider's employees from accessing sensitive or critical information or to be present at the Capitol complex based upon results addressed from a criminal background check.

Service providers should contact the West Virginia Division of Protective Services by phone at (304)558-9911 for more information.

**52. PREFERENCE FOR USE OF DOMESTIC STEEL PRODUCTS:** Except when authorized by the Director of the Purchasing Division pursuant to W. Va. Code § 5A-3-56, no contractor may use or supply steel products for a State Contract Project other than those steel products made in the United States. A contractor who uses steel products in violation of this section may be subject to civil penalties pursuant to W. Va. Code § 5A-3-56. As used in this section:

- a. "State Contract Project" means any erection or construction of, or any addition to, alteration of or other improvement to any building or structure, including, but not limited to, roads or highways, or the installation of any heating or cooling or ventilating plants or other equipment, or the supply of and materials for such projects, pursuant to a contract with the State of West Virginia for which bids were solicited on or after June 6, 2001.
- b. "Steel Products" means products rolled, formed, shaped, drawn, extruded, forged, cast, fabricated or otherwise similarly processed, or processed by a combination of two or more or such operations, from steel made by the open heath, basic oxygen, electric furnace, Bessemer or other steel making process.

The Purchasing Division Director may, in writing, authorize the use of foreign steel products if:

- a. The cost for each contract item used does not exceed one tenth of one percent (.1%) of the total contract cost or two thousand five hundred dollars (\$2,500.00), whichever is greater. For the purposes of this section, the cost is the value of the steel product as delivered to the project; or
- b. The Director of the Purchasing Division determines that specified steel materials are not produced in the United States in sufficient quantity or otherwise are not reasonably available to meet contract requirements.

**53. PREFERENCE FOR USE OF DOMESTIC ALUMINUM, GLASS, AND STEEL:** In Accordance with W. Va. Code § 5-19-1 et seq., and W. Va. CSR § 148-10-1 et seq., for every contract or subcontract, subject to the limitations contained herein, for the construction, reconstruction, alteration, repair, improvement or maintenance of public works or for the purchase of any item of machinery or equipment to be used at sites of public works, only domestic aluminum, glass or steel products shall be supplied unless the spending officer determines, in writing, after the receipt of offers or bids, (1) that the cost of domestic aluminum, glass or steel products is unreasonable or inconsistent with the public interest of the State of West Virginia, (2) that domestic aluminum, glass or steel products are not produced in sufficient quantities to meet the contract requirements, or (3) the available domestic aluminum, glass, or steel do not meet the contract specifications. This provision only applies to public works contracts awarded in an amount more than fifty thousand dollars (\$50,000) or public works contracts that require more than ten thousand pounds of steel products.

The cost of domestic aluminum, glass, or steel products may be unreasonable if the cost is more than twenty percent (20%) of the bid or offered price for foreign made aluminum, glass, or steel products. If the domestic aluminum, glass or steel products to be supplied or produced in a “substantial labor surplus area”, as defined by the United States Department of Labor, the cost of domestic aluminum, glass, or steel products may be unreasonable if the cost is more than thirty percent (30%) of the bid or offered price for foreign made aluminum, glass, or steel products.

This preference shall be applied to an item of machinery or equipment, as indicated above, when the item is a single unit of equipment or machinery manufactured primarily of aluminum, glass or steel, is part of a public works contract and has the sole purpose or of being a permanent part of a single public works project. This provision does not apply to equipment or machinery purchased by a spending unit for use by that spending unit and not as part of a single public works project.

All bids and offers including domestic aluminum, glass or steel products that exceed bid or offer prices including foreign aluminum, glass or steel products after application of the preferences provided in this provision may be reduced to a price equal to or lower than the lowest bid or offer price for foreign aluminum, glass or steel products plus the applicable preference. If the reduced bid or offer prices are made in writing and supersede the prior bid or offer prices, all bids or offers, including the reduced bid or offer prices, will be reevaluated in accordance with this rule.



**ADDITIONAL TERMS AND CONDITIONS (Construction Contracts Only)**

1. **CONTRACTOR'S LICENSE:** West Virginia Code § 21-11-2 requires that all persons desiring to perform contracting work in this state be licensed. The West Virginia Contractors Licensing Board is empowered to issue the contractor's license. Applications for a contractor's license may be made by contacting the West Virginia Division of Labor.

West Virginia Code § 21-11-11 requires any prospective Vendor to include the contractor's license number on its bid. Failure to include a contractor's license number on the bid shall result in Vendor's bid being disqualified. Vendors should include a contractor's license number in the space provided below.

Contractor's Name: CIMCO INC

Contractor's License No. WV 025512

The apparent successful Vendor must furnish a copy of its contractor's license prior to the issuance of a purchase order/contract.

2. **DRUG-FREE WORKPLACE AFFIDAVIT:** W. Va. Code § 21-1D-5 provides that any solicitation for a public improvement contract requires each Vendor that submits a bid for the work to submit at the same time an affidavit that the Vendor has a written plan for a drug-free workplace policy. To comply with this law, Vendor must either complete the enclosed drug-free workplace affidavit and submit the same with its bid or complete a similar affidavit that fulfills all of the requirements of the applicable code. Failure to submit the signed and notarized drug-free workplace affidavit or a similar affidavit that fully complies with the requirements of the applicable code, with the bid shall result in disqualification of Vendor's bid.

**2.1 DRUG-FREE WORKPLACE POLICY:** Pursuant to W. Va. Code § 21-1D-4, Vendor and its subcontractors must implement and maintain a written drug-free workplace policy that complies with said article.

The awarding public authority may cancel this contract if: (1) Vendor fails to implement and maintain a written drug-free workplace policy described in the preceding paragraph, (2) Vendor fails to provide information regarding implementation of its drug-free workplace policy at the request of the public authority; or (3) Vendor provides to the public authority false information regarding the contractor's drug-free workplace policy.

3. **DRUG FREE WORKPLACE REPORT:** Pursuant to W. Va. Code § 21-1D-7b, no less than once per year, or upon completion of the project, every contractor shall provide a certified report to the public authority which let the contract. For contracts over \$25,000, the public authority shall be the West Virginia Purchasing Division. For contracts of \$25,000 or less, the public authority shall be the agency issuing the contract. The report shall include:

- (1) Information to show that the education and training service to the requirements of West Virginia Code § 21-1D-5 was provided;
- (2) The name of the laboratory certified by the United States Department of Health and Human Services or its successor that performs the drug tests;
- (3) The average number of employees in connection with the construction on the public improvement;
- (4) Drug test results for the following categories including the number of positive tests and the number of negative tests: (A) Pre-employment and new hires; (B) Reasonable suspicion; (C) Post-accident; and (D) Random.

Vendor should utilize the attached Certified Drug Free Workplace Report Coversheet when submitting the report required hereunder.

4. **AIA DOCUMENTS:** All construction contracts that will be completed in conjunction with architectural services procured under Chapter 5G of the West Virginia Code will be governed by the AIA A101-2007 and A201-2007 or the A107-2007 documents, as amended by the Supplementary Conditions for the State of West Virginia, in addition to the terms and conditions contained herein.
5. **SUBCONTRACTOR LIST SUBMISSION:** In accordance with W. Va. Code § 5-22-1, The apparent low bidder on a contract for the construction, alteration, decoration, painting or improvement of a new or existing building or structure valued at more than \$250,000.00 shall submit a list of all subcontractors who will perform more than \$25,000.00 of work on the project including labor and materials. This provision shall not apply to any other construction projects, such as highway, mine reclamation, water or sewer projects. Additionally, if no subcontractors who will perform more than \$25,000.00 of work are to be used to complete the project, it will be noted on the subcontractor list.
  - a. **Required Information.** The subcontractor list shall contain the following information:
    - i. Bidder's name
    - ii. Name of each subcontractor
    - iii. License numbers as required by W. Va. Code § 21-11-1 et. seq.
    - iv. Notation that no subcontractor will be used to perform more than \$25,000.00 of work, when applicable
  - b. **Submission.** The completed subcontractor list shall be provided to the Purchasing Division within one business day of the opening of bids for review. Failure to submit the subcontractor list within one business day after the deadline for submitting bids shall result in disqualification of the bid.
  - c. **Substitution of Subcontractor.** Written approval must be obtained from the State Spending Unit before any subcontractor substitution is permitted. Substitutions are not permitted unless:

- i. The subcontractor listed in the original bid has filed for bankruptcy;
  - ii. The subcontractor in the original bid has been debarred or suspended; or
  - iii. The contractor certifies in writing that the subcontractor listed in the original bill fails, is unable, or refuses to perform his subcontract.
6. **GREEN BUILDINGS MINIMUM ENERGY STANDARDS:** In accordance with § 22-29-4, all new building construction projects of public agencies that have not entered the schematic design phase prior to July 1, 2012, or any building construction project receiving state grant funds and appropriations, including public schools, that have not entered the schematic design phase prior to July 1, 2012, shall be designed and constructed complying with the ICC International Energy Conservation Code, adopted by the State Fire Commission, and the ANSI/ASHRAE/IESNA Standard 90.1-2007: *Provided*, That if any construction project has a commitment of federal funds to pay for a portion of such project, this provision shall only apply to the extent such standards are consistent with the federal standards.

REQUEST FOR QUOTATION  
HOP14103 BOILER REPAIRS TO MORGAN HALL AND REPLACE  
THE CONTROL PANEL IN UNITS BUILDING

---

SPECIFICATIONS

1. **PURPOSE AND SCOPE:** The West Virginia Purchasing Division is soliciting bids on behalf of WVDHHR/Hopemont Hospital to establish a contract for the one time purchase of Replacement of (1) Intermediate Cast Iron Section #5 in Middle of HB Smith Cast Iron Boiler M/N 3500 located in the Morgan Hall building and replace Control Panel with Control System International Model# 7728 or equal in basement of Unit Building located at Hopemont Hospital.
2. **DEFINITIONS:** The terms listed below shall have the meanings assigned to them below. Additional definitions can be found in section 2 of the General Terms and Conditions.
  - 2.1 **“Contract Item”** means Replacement of (1) Intermediate Cast Iron Section #5 in Middle of HB Smith Cast Iron Boiler M/N 3500, located in the Morgan Hall building at Hopemont Hospital.
  - 2.2 **“Contract Item”** means Replacement of the Control Panel with Control System International Model#7728 or equal in basement of unit Building at Hopemont Hospital.
  - 2.3 **“Pricing Page”** means the pages upon which Vendor should list its proposed price for the Contract Items in the manner requested. The Pricing Page is either included on the last page of this RFQ.
  - 2.4 **“RFQ”** means the official request for quotation published by the Purchasing Division and identified as HOP14103.
3. **GENERAL REQUIREMENTS:**
  - 3.1 **Mandatory Contract Item Requirements:** Contract Item must meet or exceed the mandatory requirements listed below.
    - 3.1.1 Replace (1) Intermediate Cast Iron Section #5 in Middle of HB Smith Cast Iron Boiler M/N 3500.
      - 3.1.1.1 The vendor shall remove and replace the existing Intermediate Cast Iron Section #5 in Middle of the existing HP Smith Cast Iron Boiler Model #3500 with same or equal.

**REQUEST FOR QUOTATION  
HOP14103 BOILER REPAIRS TO MORGAN HALL AND REPLACE  
THE CONTROL PANEL IN UNITS BUILDING**

---

**3.1.1.2** Vendor will replace all nipples on sections that have to be removed. Install new Gaskets, Install a new Refractor Fire Box, and perform combustion analyses on burner after repairs are made.

**3.1.1.3** Vendor shall keep the work area as clean as possible during the entire progress of work, and shall be responsible to remove from the site, the packing materials from his products and other debris as it accumulates. All items of equipment that are removed to allow the installation of new items will become the property of the vendor to dispose of at a landfill or location authorized to accept the items as waste or recycled parts.

**3.1.2** Replace Control Panel for Boiler systems with Control System International Model # 7728 (custom control for this specific application) or equal in the Units Basement, located at Hopemont Hospital. Resource used for Control Panel: [www.csicontrols.com](http://www.csicontrols.com).

**3.1.2.1** The vendor shall remove the existing Control Panel and replace with Control System International Model#7728 or equal.

**3.1.2.2** The vendor shall to provide all labor and materials or incidentals to replace Control Panel.

**3.1.2.3** The vendor shall provide analysis and testing of the new control panel to insure proper functionality acceptable to the Agency.

**3.1.2.4** The vendor shall provide training for use of the new control panel system to Hopemont Maintenance staff within 1-3 days of installation.

**4. CONTRACT AWARD:**

**4.1 Contract Award:** The Contract is intended to provide Agencies with a purchase price for the Contract Items. The Contract shall be awarded to the Vendor that provides the Contract Items meeting the required specifications for the lowest overall lump sum cost as shown on the Pricing Pages.

REQUEST FOR QUOTATION  
HOP14103 BOILER REPAIRS TO MORGAN HALL AND REPLACE  
THE CONTROL PANEL IN UNITS BUILDING

---

**4.2 Pricing Page:** Vendor should complete the Pricing Page by Cost to be lump Sum figure to include all labor, materials, equipment training, and anything incidental to remove and replace **Item#1** (3.1.1) One (1) Intermediate Cast Iron Section #5 in Middle of boiler. **Item#2** (3.1.2) Replace the control panel with Control System International Model #7728 or equal in basement of units building. Vendor to provide training for use of the new control panel system to Hopemont Maintenance staff within 1-3 days of installation. Vendor should complete the Pricing Page in full as failure to complete the Pricing Page in its entirety may result in Vendor's bid being disqualified.

Notwithstanding the foregoing, the Purchasing Division may correct errors as it deems appropriate. Vendor should type or electronically enter the information into the Pricing Page to prevent errors in the evaluation.

**5. PAYMENT:**

**5.1 Payment:** Vendor shall accept payment in accordance with the payment procedures of the State of West Virginia.

**6. DELIVERY AND RETURN:**

**6.1 Shipment and Delivery:** Vendor shall ship the Contract Items immediately after being awarded this Contract and receiving a notice to proceed. Contract items must be delivered to Morgan Hall and the Units Building at Hopemont Hospital, 150 Hopemont Drive, Terra Alta, W.V. 26764. Vendor shall deliver the Contract Items within 45 days after receiving a notice to proceed.

**6.2 Late Delivery:** The Agency placing the order under this Contract must be notified in writing if the shipment of the Contract Items will be delayed for any reason. Any delay in delivery that could cause harm to an Agency will be grounds for cancellation of the Contract, and/or obtaining the Contract Items from a third party.

Any Agency seeking to obtain the Contract Items from a third party under this provision must first obtain approval of the Purchasing Division.

**6.3 Delivery Payment/Risk of Loss:** Vendor shall deliver the Contract Items F.O.B. destination to the Agency's location.

**6.4 Return of Unacceptable Items:** If the Agency deems the Contract Items to be unacceptable, the Contract Items shall be returned to Vendor at Vendor's expense and with no restocking charge. Vendor shall either make arrangements for the return within five (5) days of being notified that items are unacceptable, or permit

REQUEST FOR QUOTATION  
HOP14103 BOILER REPAIRS TO MORGAN HALL AND REPLACE  
THE CONTROL PANEL IN UNITS BUILDING

---

the Agency to arrange for the return and reimburse Agency for delivery expenses. If the original packaging cannot be utilized for the return, Vendor will supply the Agency with appropriate return packaging upon request. All returns of unacceptable items shall be F.O.B. the Agency's location. The returned product shall either be replaced, or the Agency shall receive a full credit or refund for the purchase price, at the Agency's discretion.

- 6.5 Return Due to Agency Error:** Items ordered in error by the Agency will be returned for credit within 30 days of receipt, F.O.B. Vendor's location. Vendor shall not charge a restocking fee if returned products are in a resalable condition. Items shall be deemed to be in a resalable condition if they are unused and in the original packaging. Any restocking fee for items not in a resalable condition shall be the lower of the Vendor's customary restocking fee or 5% of the total invoiced value of the returned items.

# URNER

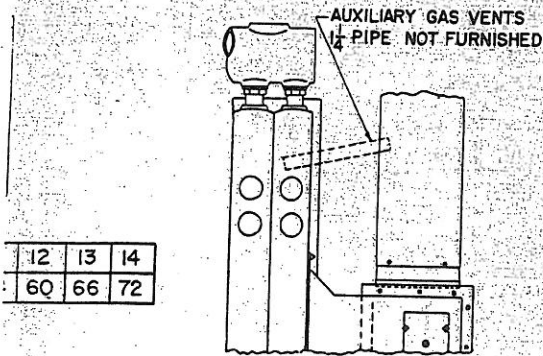

SIDE VIEW-GAS FIRED

OPTIONAL DISCHARGE POSITIONS—AUBURN INDUCED DRAFT FAN

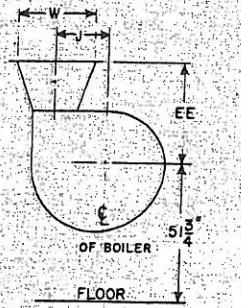

TOP VERTICAL DISCHARGE  
CLOCKWISE ROTATION  
(This view as seen from back of boiler)

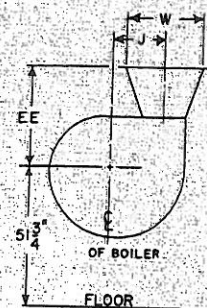

TOP VERTICAL DISCHARGE  
COUNTERCLOCKWISE ROTATION  
(This view as seen from back of boiler)

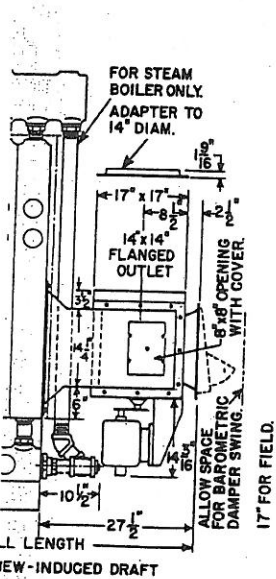

SIDE VIEW  
INDUCED DRAFT  
INDUCED DRAFT

TOP 45° DISCHARGE  
COUNTER CLOCKWISE ROTATION  
OPPOSITE HAND TO  
VIEW SHOWN!

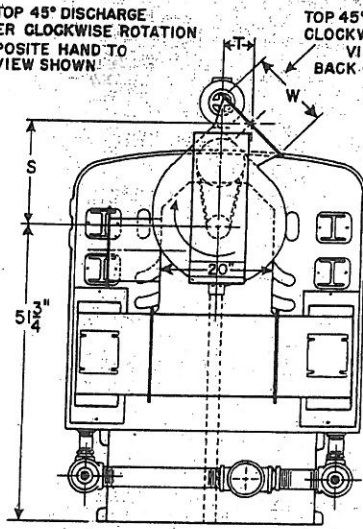

REAR VIEW  
AUBURN FAN

TOP 45° DISCHARGE  
CLOCKWISE ROTATION  
VIEW FROM  
BACK OF BOILER

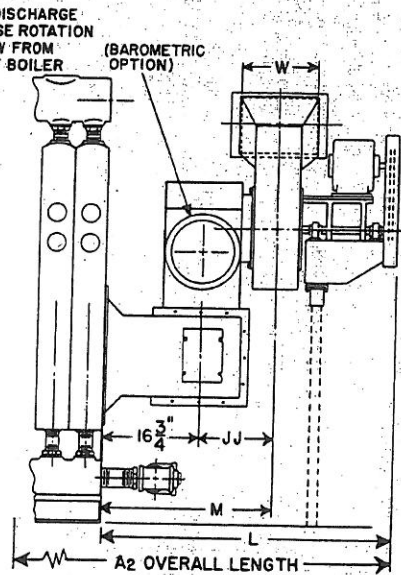

SIDE VIEW  
AUBURN FAN

## MILLS 3500

Boiler Model Number	Smokehood Outlet Adapter (Inches) Natural Draft			Auburn Fan Dimensions (Inches)								Burner Model Number				Electrical Requirements				Boiler Model Number		
												Carlin		Power-Flame		Burner Motor (HP) (Note 8)					Induced Draft Fan Motor (HP)	
	Oil LO3500	Oil LO3500	Gas G3500	Gas/Oil GO3500	Carlin	Power-Flame	Carlin	Power-Flame	Carlin	Power-Flame	Wing	Auburn										
	N	O	P	J	L	M	S	T	W	EE	JJ	LO3500	LO3500	G3500	GO3500	Wing	Auburn					
1/2	13 3/4	13 3/4	4 1/4									801CRD	C2-OA	C2-G-15	C2-GO-15	3/4	3/4	1/2	3/4	1/4	1/4	13500-Δ-6
1/2	15 1/4	13 3/4	3 3/4									801CRD	C2-OA	C2-G-15	C2-GO-15	3/4	3/4	1/2	3/4	1/4	1/4	13500-Δ-7
1/2	17 1/4	13 3/4	2 1/4									801CRD	C2-OA	C2-G-20A	C2-GO-20A	3/4	1	3/4	1	1/4	1/4	13500-Δ-8
1/2	17 1/4	13 3/4	2 1/4	8 1/2	47	29 3/4	17 1/4	5 1/4	12	16	12 1/4	801CRD	C2-OB	C2-G-20B	C2-GO-20B	3/4	1	3/4	1	1/2	1/2	13500-Δ-9
1/2	17 1/4	13 3/4	2 1/4									1050FFD	C2-OB1	C2-G-20B1	C2-GO-20B1	1	1	3/4	1	1/2	1/2	13500-Δ-10
1/2	-	-	-									1050FFD	C3-O	C3-G-20	C3-GO-20	1	2	1 1/2	2	1/2	1/2	13500-Δ-11
1/2	-	-	-	9 1/2	53 1/4	30	19	5 3/4	14	17 1/2	15 1/4	1150FFD	C3-O	C3-G-20	C3-GO-20	1 1/2	2	1 1/2	2	1/2	1/2	13500-Δ-12
1/2	-	-	-									1150FFD	C3-O	C3-G-25	C3-GO-25	1 1/2	2	1 1/2	2	3/4	3/4	13500-Δ-13
1/2	-	-	-									1150FFD	C3-O	C3-G-25	C3-GO-25	1 1/2	2	1 1/2	2	3/4	3/4	13500-Δ-14

The manufacturer should be consulted before selecting a boiler having unusual piping and pick-up requirements, such as intermittent system operation, extensive piping, etc.

For forced hot water heating systems where the boiler and all the piping are within the area to be heated, the boiler may be selected on the basis of gross output. Note 8 Fractional horsepower motors are for operation with 115/230V, 60-Hz current at constant speed. Integral horsepower motors are for 230/460V, 60-Hz or 208V, 60-Hz current at constant speed.

Other voltages and variable speed options are available on special order.



## Existing Boiler Diagram & Specifications

**OIL - GAS**  
**or**  
**COMBINATION GAS/LIGHT OIL**  
**I=B=R RATINGS: GROSS OUTPUT 1,200 to 3,500 MBH**

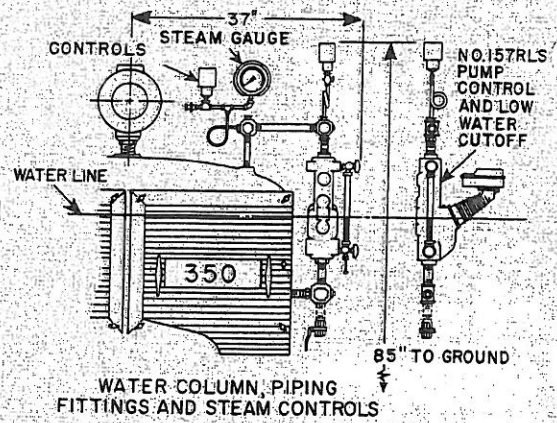

WATER COLUMN, PIPING, FITTINGS AND STEAM CONTROLS

WATER COLUMN, PIPING, FITTINGS AND STEAM CONTROLS

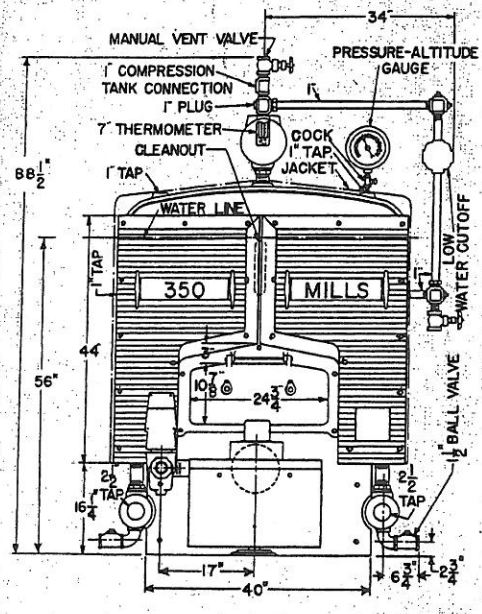

FRONT VIEW - WATER

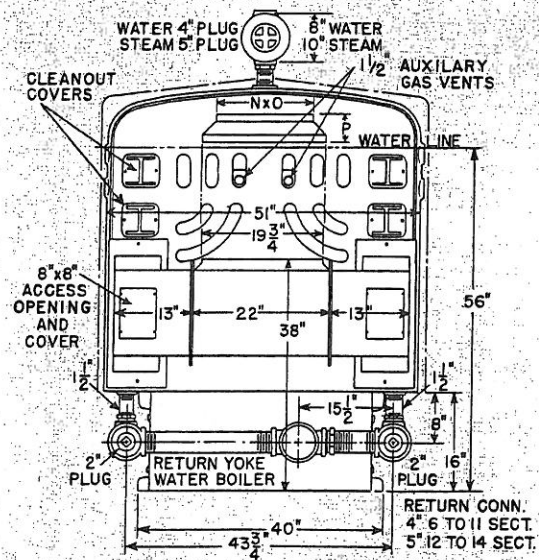

REAR VIEW - NATURAL DRAFT - WATER

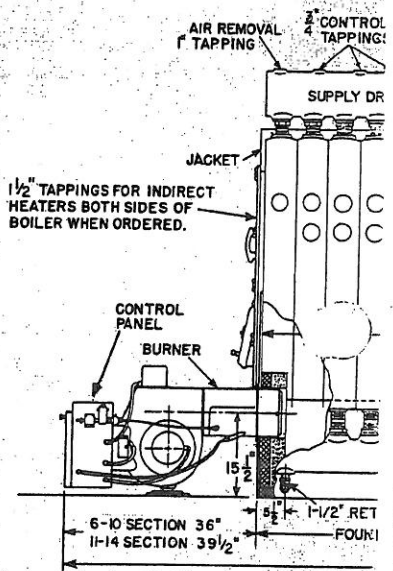

SIDE VIEW - NATURAL DRAFT

### I=B=R RATINGS, BURNER CAPACITIES, DRAFT and CHIMNEY DATA

DESIGNED AND TESTED ACCORDING TO ... ING PRESSURE. STEAM 15 LBS. WATER

BOILER MODEL NUMBER	Boiler Horsepower	I=B=R Gross Output (MBH)	NET I=B=R RATINGS			I=B=R Burner Capacity		Draft Requirements (Inches, W.C.)			Natural Draft Chimney		Induced Draft Fan Capacity CFM (Wing & Auburn)	Induced Draft Fan Catalog Number (Note 5)	
			Steam		Water	Oil GPH (Note 3)	Gas MBH	Over Fire	Draft Loss	Total	Size (Inches)	Height (Feet) (Note 4)		Wing Fan to Fit Smokehood	Auburn Fan and Smokehood to Fit Boiler
			Sq. Ft.	MBH (Note 1)	MBH (Note 2)										
†3500-Δ-6	35.8	1,200	3,750	900.2	1,043.5	10.8	1557	.02	.06	.08	16 x 16	19	575	14D-¼	12A25
†3500-Δ-7	44.4	1,488	4,730	1,135.0	1,293.9	13.4	1932	.02	.08	.10	16 x 20	23	713	14D-¼	12A25
†3500-Δ-8	53.0	1,776	5,730	1,374.6	1,544.3	16.0	2307	.02	.09	.11	20 x 20	26	851	14D-¼	12A33
†3500-Δ-9	61.6	2,064	6,675	1,602.5	1,794.8	18.6	2682	.02	.11	.13	20 x 20	30	990	14D-½	12A33
†3500-Δ-10	70.2	2,352	7,610	1,826.1	2,045.2	21.0	3028	.02	.12	.14	20 x 20	33	1,117	14D-½	12A50
†3500-Δ-11	78.7	2,636	8,525	2,042.6	2,292.2	23.5	3389	.02	.14	.16	20 x 24	37	1,250	14D-½	12A50
†3500-Δ-12	87.4	2,924	9,460	2,270.2	2,542.6	26.0	3749	.02	.16	.18	20 x 24	40	1,383	14D-½	14A50
†3500-Δ-13	95.9	3,210	10,385	2,492.2	2,791.3	28.5	4110	.02	.17	.19	24 x 24	44	1,516	14D-¾	14A75
†3500-Δ-14	104.5	3,500	11,320	2,717.4	3,043.5	31.5	4542	.02	.19	.21	24 x 24	47	1,676	14D-¾	14A75

† Insert "LO" for Light Oil, "G" for Gas, "G/O" for Gas/Oil.  
 Δ Insert "S" for Steam, "W" for Water.

Note 1 Net I=B=R Steam Ratings shown are based on piping and pick-up allowances of 1.288 except for 6 Section (1.333), 7 Section (1.333), and 8 Section (1.292).

Note 2 Net I=B=R Water Ratings shown are based on an allowance of 1.15.

Note 3 Based on Light Oil having a heat content of 140,000 Btu/Gal.

# 100 QUICK RESPONSE BOILER-B

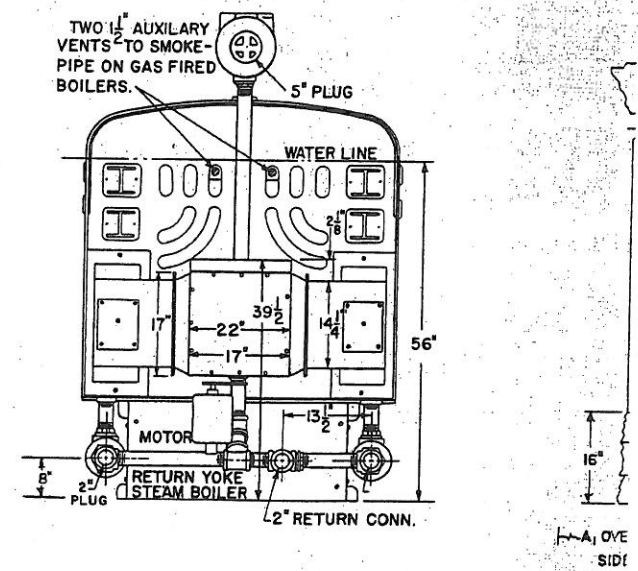
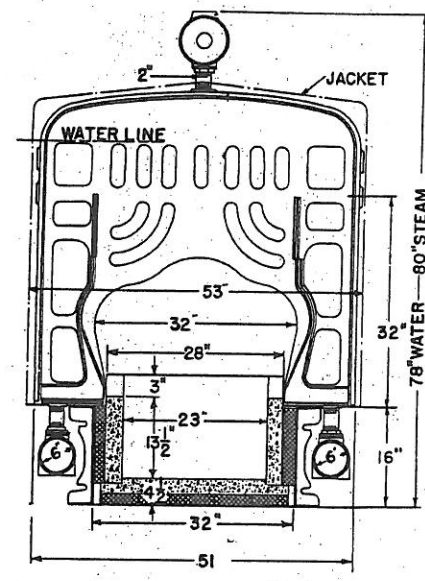
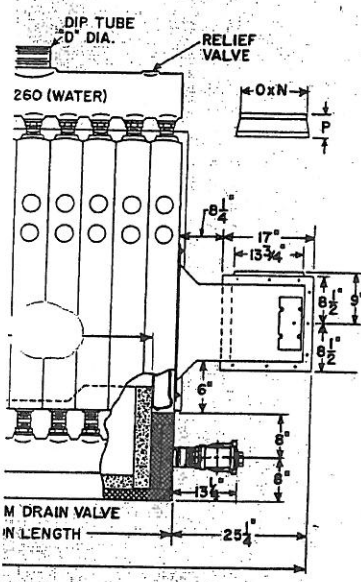
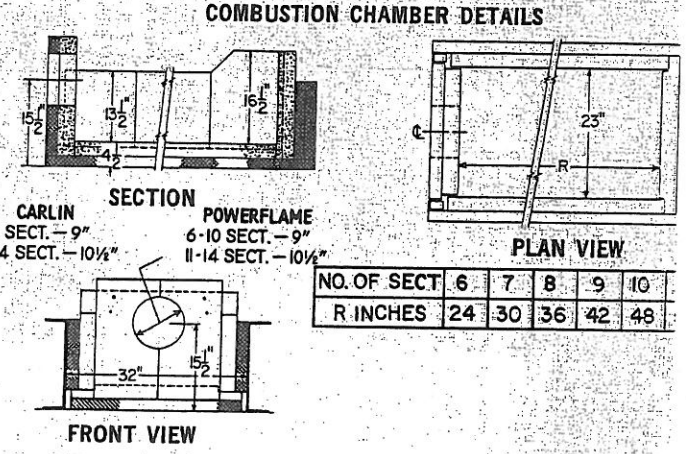
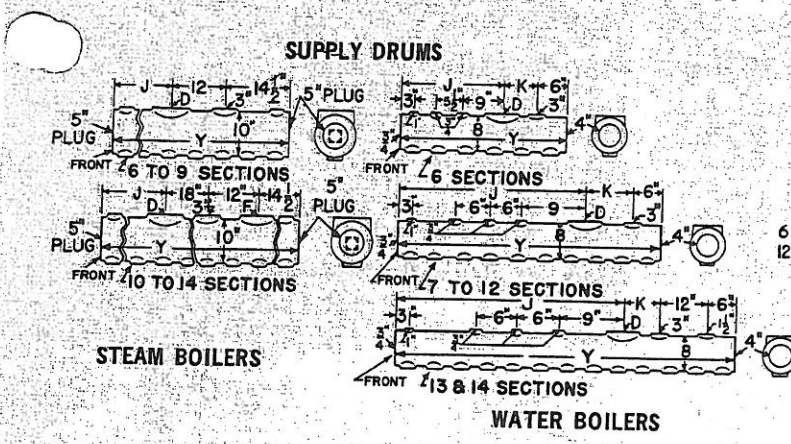

WATER - POWERFLAME

INTERMEDIATE SECTION

REAR VIEW WING FAN

S.M.E. BOILER AND PRESSURE VESSEL CODE, SECTION IV FOR MAXIMUM ALLOWABLE WORK BS. FOR 80 PSI WORKING PRESSURE CONSULT THE H.B. SMITH CO., INC.

Induced Draft Chimney, Inside Dimensions			Heating Surface (Sq. Ft.)	Furnace Volume (Cu. Ft.) (Note 6)	Water Content (Gals.)		Weight (Lbs.) (Note 7)
Metal Flue Pipe or Smooth Lined Masonry (in.)		Unlined Brick (Nom. Inches)			Steam	Water	
Round (I.D.) Min.	Rectangular Minimum	Rectangular Minimum					
13	9½ x 13½	12 x 16	168.4	16.43	68.5	107.0	4,755
13	9½ x 13½	12 x 16	197.6	19.67	79.0	123.0	5,285
14	13¼ x 13¼	16 x 16	226.4	22.91	89.0	139.5	5,910
15	13 x 17	16 x 20	255.6	26.15	99.5	156.0	6,575
16	13 x 17	16 x 20	284.8	29.39	110.0	172.0	7,300
17	16¾ x 16¾	20 x 20	313.6	32.64	120.0	188.0	7,880
17	16¾ x 16¾	20 x 20	342.8	35.88	130.0	204.5	8,475
18	16½ x 20½	20 x 24	371.6	39.12	140.5	221.0	9,130
18	16½ x 20½	20 x 24	400.8	42.36	151.0	237.0	9,705

## DIMENSIONS, ELECTRICAL REQUIREMENTS

Overall Length (Inches)			Furnace Length (Inches)	Foundation Length (In.)	Water Supply Drum			Steam Supply		
All Models					Tapping Size (Inches)	Tapping Location (Inches)		Tapping Size (Inches)		Tapping Location (In.)
Natural Draft	Wing Fan	Auburn Fan	A	J		K	Y	D	F	
97%	A1	A2	B	4	21	9	36	6	-	15
103%	117	119½	32¼	4	27	9	42	6	-	21
109%	123	125½	38¾	4	27	15	48	6	-	27
115%	129	131½	44¼	4	33	15	54	6	-	33
121%	135	137½	50¼	4	33	21	60	6	6	21
131%	144%	147¼	56¼	4	39	21	66	6	6	27
131%	150%	153¼	62¼	4	39	21	66	6	6	27
137½	156%	165½	68¼	5	45	21	72	6	6	33
143½	162%	171½	74¼	5	39	21	78	6	6	39
149½	168%	177½	80¼	5	45	21	84	6	6	45

- Note 4 Chimney height shall be sufficient to avoid creating a nuisance. See chart, "Induced Draft Chimney" for inside dimensions.
- Note 5 The induced draft fan selections listed are based on a chimney capable of offsetting the friction in the fan discharge connection. For other conditions, consult your H.B. Smith representative.
- Note 6 Includes the volume of the precast combustion chamber.
- Note 7 Includes boiler castings, trim, draft inducer, combustion chamber and jacket. To obtain gross operating weight, add weight of water.

# 3500 SPECIFICATIONS

## BURNERS:

The forced draft flame retention burners for light oil, gas, or gas-oil firing are U.L. certified and have been custom designed for optimum performance in each size 3500 unit.

All burners have prewired burner mounted controls with standard low fire start, high fire run, and two position air control.

Burner specification sheet lists standard and optional burner components.

Burners can be furnished for lo-hi-lo and full modulation firing, and equipped with control systems to comply with most insurance and state or local code requirements.

## STANDARD EQUIPMENT

### ALL UNITS

- Foundation front plate completely cut and tapped.
- Insulated metal jacket.
- Pre-cast combustion chamber complete with insulating blocks.
- Return yoke with flexible seals.
- Two 1 1/2" drain valves with pipe and fittings.

### WATER UNITS

- Manual reset high-temperature limit control.
- Operating temperature control.
- ASME relief valve set at 40 psi.
- Low water cut-off and piping.
- Pressure-altitude gauge.
- Mercury column thermometer.
- Dip tube.
- Air removal fitting.
- Manual air vent valve.

### STEAM UNITS

- Manual reset high-pressure limit control.
- Operating pressure control.
- Syphon, pipe tree for control mounting including inspector's gauge cock.
- ASME side-outlet safety valve set at 15 psi.
- Combination water column, low water cut-off and pump controller with piping.
- 4 1/2" pressure gauge.

### GAS UNITS

- Forced draft flame retention power burner (Model CG).
- Prewired electronic burner-mounted control panel with numbered terminal strip (115V, 1 phase, 60-Hz control circuit).
- U. L. approved gas train.

### OIL UNITS

- Pressure-atomizing oil burner (low-high-off) fire-tested at the factory.
- Prewired burner-mounted controls.

### COMBINATION GAS/OIL UNITS

- Forced draft pressure atomizing flame retention combination gas/oil burner (Model CGO).
- Prewired electronic burner-mounted control panel with numbered terminal strip (115V, 1 phase, 60-Hz control circuit).
- U. L. approved gas train.

## OPTIONAL EQUIPMENT

- Combination water feeder and low water cut-off. (Steam boilers only, piping not included.)
- Field draft control for natural draft units in the following sizes: 12" (6 section), 14" (7 section), 16" (8-10 section), and 18" (11-14 section).
- Induced draft fan—Wing or Auburn. Fan systems are equipped with constant speed 1,750 rpm, 60-Hz motor. Adjustable pitch sheaves are used to achieve fan speed regulation.
- Draft control panel which includes magnetic starter, prepurge and draft safety switch and eight-point terminal block (1 phase) or 12-point terminal block (3 phase) installed and wired in panel box suitable for wall mounting. Red warning light (for low draft condition) in cover.
- Field draft controls with special mounting collars are available for Auburn and Wing fans.
- Start-up and one year's service.

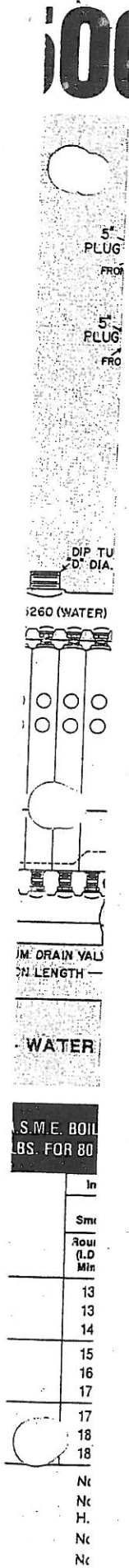

S. M. E. BOIL  
LBS. FOR 80

In
13
13
14
15
16
17
17
18
18
Nc
Nc
H.
Nc
Nc

# MAKEUP WATER FOR STEAM BOILERS

In modern automatic intermittently operating steam heating systems there regularly occurs a period of pickup during which the return of condensate from the system lags behind the evaporation from the boiler. The duration of this pickup period varies according to the physical characteristics of the system. It is generally agreed that average systems require from 15 to 30 minutes to achieve a balance between condensate return and evaporation. With modern fast steaming boilers, careful consideration of the provisions for makeup water must be given to insure the following operating results:

1. Maintain a safe, effective boiler water line.
2. Avoid the introduction of excessive amounts of raw makeup water.
3. Prevent nuisance burner shut-down because of temporary low water level.

In some localities standard practice for compact piping systems has consisted of providing an automatic water feeder to supply makeup water directly to the boiler according to drop in water level. This arrangement requires the introduction of raw makeup water during each pickup period and, in most instances, the excess system water must be drained manually at frequent intervals. Operation in this manner usually results in increased corrosion of system components and the consequent added maintenance. Some states and municipalities require a mechanical water feeder for all steam boilers to function as a safety feeder. This feeder should be set to commence feeding when water level is approximately 1 inch above the bottom of the gauge glass but does not function as a principal source of makeup water.

The H. B. Smith Co. recommends a feed water system capable of satisfying the three previously listed requirements. It should include a condensate return unit consisting of at least one condensate pump sized to feed water to the boilers at a rate sufficient to maintain operating water level at full boiler rated output and a condensate receiver having sufficient storage capacity to provide for the operation of the boiler during start-up of a cold system.

In the following schedule, the minimum recommended pumping rates and storage capacities for each 3500 Series boiler size are listed. For two boilers, the pumping rate and storage capacity should be doubled.

No. of Boiler Sections	SCHEDULE 1	
	Minimum Pumping Rate GPM (1)	Minimum Receiver Capacity Gals. (2) (3)
6	5	47
7	6 $\frac{1}{4}$	58
8	7 $\frac{1}{2}$	70
9	8 $\frac{3}{4}$	80
10	10	92
11	11	103
12	12 $\frac{1}{4}$	114
13	13	122
14	14 $\frac{3}{4}$	137

This schedule is based on the following:

1. Minimum recommended pumping rate is double the boiler evaporating rate at catalog rating.
2. Minimum storage capacity will provide 15 minutes of boiler operation at full rating using 80 percent of the receiver capacity without the addition of makeup water. Makeup water feeder should be set to commence feeding when receiver water level drops to  $\frac{1}{3}$  full.
3. The receiver capacities shown are considered adequate only for compact buildings. Receivers for extended buildings require two or three times larger tanks depending upon the sizes, length, and pitch of the piping.

For single boiler applications, the pump controller furnished with the boiler can be used to start and stop condensate pump. For two or more boilers each pump controller should be wired to start and stop the pump and, in addition, a positive closing water level regulator or electric valve must be provided in the feed connection to each boiler. In all instances a manual fill connection to each boiler should be provided.

The H. B. Smith Company does not furnish the condensate return units or water level regulators.

In the interest of product improvement, H.B. Smith reserves the right to make changes without notice.

## HBSmith

260 North Elm Street • Westfield, MA 01085 • (413) 562-9631 • FAX: (413) 562-3799

Printed in U.S.A.

**HOP14103****PRICING PAGE**

Cost to be a lump sum figure to include all labor, materials, equipment, training and anything incidental to replace (1) Intermediate Cast Iron Section in Middle of boiler located in Morgan Hall and Replace Control Panel to the Boiler System in Units Basement of Hopemont Hospital located at 150 Hopemont Drive, Terra Alta WV 26764 as per the specifications within this Request for Quotations.

Item#1: Replace (1) Intermediate Cast Iron Section #5 in Middle of HB Smith Cast Iron Boiler M/N 3500.

Item#1 Bid \$ 24,718.00

Item#2: Replace Control Panel for Boiler systems with Control System International Model#7728 (custom control for this specific application) or equal in the Units Basement, located at Hopemont Hospital, Bid to include training.

Item#2 Bid \$ 21,140.00

Overall Total Lump Sum Cost: \$ 45,858.00

Contractor's Name: CIMCO INC

Contractor's Address: Po Box 480 Culloden WV. 25510

Phone Number of Contact: 304-562-7705

Fax Number of Contact: 304-397-4178

E-Mail Address of Contact: JL.Gillenwater@Cimco WV.com

Signature: 

Date of Signature: 12/11/13

Basis of Award: Award to be made to the vendor that provides the Contract Services meeting the required specifications for the lowest overall total lump sum cost.

**CERTIFICATION AND SIGNATURE PAGE**

By signing below, I certify that I have reviewed this Solicitation in its entirety; understand the requirements, terms and conditions, and other information contained herein; that I am submitting this bid or proposal for review and consideration; that I am authorized by the bidder to execute this bid or any documents related thereto on bidder's behalf; that I am authorized to bind the bidder in a contractual relationship; and that to the best of my knowledge, the bidder has properly registered with any State agency that may require registration.

CIMCO INC.

(Company)

Jeff Gillenwater

(Authorized Signature)

Jeff Gillenwater Service Mgr

(Representative Name, Title)

304-562-7705      304-397-4178

(Phone Number)

(Fax Number)

12-11-13

(Date)



State of West Virginia  
DRUG FREE WORKPLACE CONFORMANCE AFFIDAVIT  
West Virginia Code §21-1D-5

STATE OF WEST VIRGINIA,  
COUNTY OF Putnam, TO-WIT:

I, MITCHELL SMITH, after being first duly sworn, depose and state as follows:

- 1. I am an employee of CIMCO INC; and,  
(Company Name)
- 2. I do hereby attest that CIMCO INC  
(Company Name)

maintains a valid written drug free workplace policy and that such policy is in compliance with **West Virginia Code §21-1D**.

The above statements are sworn to under the penalty of perjury.

By: Mitchell Smith  
 Title: PRESIDENT  
 Company Name: Cimco Inc  
 Date: 12/11/13

Taken, subscribed and sworn to before me this 11<sup>th</sup> day of Dec., 2013.

By Commission expires August 13, 2018

(Seal)

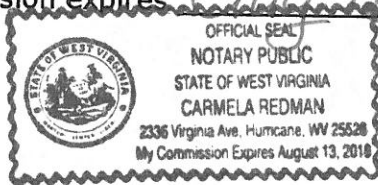

Carmela Redman  
(Notary Public)

**THIS AFFIDAVIT MUST BE SUBMITTED WITH THE BID IN ORDER TO COMPLY WITH WV CODE PROVISIONS. FAILURE TO INCLUDE THE AFFIDAVIT WITH THE BID SHALL RESULT IN DISQUALIFICATION OF THE BID.**

STATE OF WEST VIRGINIA  
Purchasing Division

**PURCHASING AFFIDAVIT**

**MANDATE:** Under W. Va. Code §5A-3-10a, no contract or renewal of any contract may be awarded by the state or any of its political subdivisions to any vendor or prospective vendor when the vendor or prospective vendor or a related party to the vendor or prospective vendor is a debtor and: (1) the debt owed is an amount greater than one thousand dollars in the aggregate; or (2) the debtor is in employer default.

**EXCEPTION:** The prohibition listed above does not apply where a vendor has contested any tax administered pursuant to chapter eleven of the W. Va. Code, workers' compensation premium, permit fee or environmental fee or assessment and the matter has not become final or where the vendor has entered into a payment plan or agreement and the vendor is not in default of any of the provisions of such plan or agreement.

**DEFINITIONS:**

**"Debt"** means any assessment, premium, penalty, fine, tax or other amount of money owed to the state or any of its political subdivisions because of a judgment, fine, permit violation, license assessment, defaulted workers' compensation premium, penalty or other assessment presently delinquent or due and required to be paid to the state or any of its political subdivisions, including any interest or additional penalties accrued thereon.

**"Employer default"** means having an outstanding balance or liability to the old fund or to the uninsured employers' fund or being in policy default, as defined in W. Va. Code § 23-2c-2, failure to maintain mandatory workers' compensation coverage, or failure to fully meet its obligations as a workers' compensation self-insured employer. An employer is not in employer default if it has entered into a repayment agreement with the Insurance Commissioner and remains in compliance with the obligations under the repayment agreement.

**"Related party"** means a party, whether an individual, corporation, partnership, association, limited liability company or any other form or business association or other entity whatsoever, related to any vendor by blood, marriage, ownership or contract through which the party has a relationship of ownership or other interest with the vendor so that the party will actually or by effect receive or control a portion of the benefit, profit or other consideration from performance of a vendor contract with the party receiving an amount that meets or exceed five percent of the total contract amount.

**AFFIRMATION:** By signing this form, the vendor's authorized signer affirms and acknowledges under penalty of law for false swearing (W. Va. Code §61-5-3) that neither vendor nor any related party owe a debt as defined above and that neither vendor nor any related party are in employer default as defined above, unless the debt or employer default is permitted under the exception above.

**WITNESS THE FOLLOWING SIGNATURE:**

Vendor's Name: Cimco Inc

Authorized Signature: Mitchell S. Smith Date: 12/11/13

State of West Virginia

County of Putnam, to-wit:

Taken, subscribed, and sworn to before me this 11<sup>th</sup> day of December, 2013

My Commission expires August 13, 2018

**AFFIX SEAL HERE**

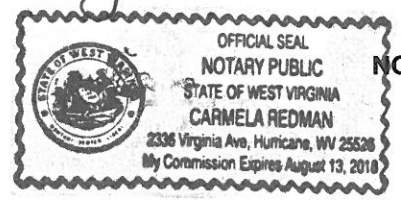

NOTARY PUBLIC Carmela Redman



**ADDENDUM ACKNOWLEDGEMENT FORM**  
**SOLICITATION NO.: HOP14103**

**Instructions:** Please acknowledge receipt of all addenda issued with this solicitation by completing this addendum acknowledgment form. Check the box next to each addendum received and sign below. Failure to acknowledge addenda may result in bid disqualification.

**Acknowledgment:** I hereby acknowledge receipt of the following addenda and have made the necessary revisions to my proposal, plans and/or specification, etc.

**Addendum Numbers Received:**

(Check the box next to each addendum received)

- |  |  |
|--|--|
| <input checked="" type="checkbox"/> Addendum No. 1 | <input type="checkbox"/> Addendum No. 6  |
| <input checked="" type="checkbox"/> Addendum No. 2 | <input type="checkbox"/> Addendum No. 7  |
| <input type="checkbox"/> Addendum No. 3            | <input type="checkbox"/> Addendum No. 8  |
| <input type="checkbox"/> Addendum No. 4            | <input type="checkbox"/> Addendum No. 9  |
| <input type="checkbox"/> Addendum No. 5            | <input type="checkbox"/> Addendum No. 10 |

I understand that failure to confirm the receipt of addenda may be cause for rejection of this bid. I further understand that any verbal representation made or assumed to be made during any oral discussion held between Vendor's representatives and any state personnel is not binding. Only the information issued in writing and added to the specifications by an official addendum is binding.

*CIMCO Inc*

\_\_\_\_\_  
Company

*Jeff Hellenmeyer*

\_\_\_\_\_  
Authorized Signature

*12-11-13*

\_\_\_\_\_  
Date

**NOTE:** This addendum acknowledgment should be submitted with the bid to expedite document processing.



State of West Virginia  
 Department of Administration  
 Purchasing Division  
 2019 Washington Street East  
 Post Office Box 50130  
 Charleston, WV 25305-0130

**Solicitation**

NUMBER
HOP14103

PAGE
1

ADDRESS CORRESPONDENCE TO ATTENTION OF:
ROBERTA WAGNER 304-558-0067

\*B22102807                      304-562-0121

VENDOR

CIMCO INC  
 2336 VIRGINIA AVE  
 HURRICANE WV 25526

SHIP TO

HEALTH AND HUMAN RESOURCES  
 HOPEMONT HOSPITAL  
 CENTRAL RECEIVING  
 150 HOPEMONT DRIVE  
 TERRA ALTA, WV  
 26764-7728                      304-789-2411

DATE PRINTED
11/08/2013

BID OPENING DATE: 12/11/2013

BID OPENING TIME 1:30PM

LINE	QUANTITY	UOP	CAT. NO.	ITEM NUMBER	UNIT PRICE	AMOUNT
				ADDENDUM NO. 1		
				ADDENDUM IS ISSUED:		
				1. TO SEND OUT FORMS NEEDED TO COMPLETE THE SOLICITATION PACKAGE.		
				2. TO PROVIDE ADDENDUM ACKNOWLEDGEMENT. THIS DOCUMENT SHOULD BE SIGNED AND RETURNED WITH YOUR BID. FAILURE TO SIGN AND RETURN MAY RESULT IN THE DISQUALIFICATION OF YOUR BID.		
				***** END OF ADDENDUM NO. 1 *****		

RECEIVED  
 NOV 13 2013

SIGNATURE <i>Jeff Silliman</i>	TELEPHONE 304-562-7205	DATE 12-11-13
TITLE <i>Service Mgr</i>	FEIN 55-0749511	ADDRESS CHANGES TO BE NOTED ABOVE

WHEN RESPONDING TO SOLICITATION, INSERT NAME AND ADDRESS IN SPACE ABOVE LABELED 'VENDOR'

**SOLICITATION NUMBER: HOP14103**  
**Addendum Number: 1**

---

The purpose of this addendum is to modify the solicitation identified as (“Solicitation”) to reflect the change(s) identified and described below.

**Applicable Addendum Category:**

- Modify bid opening date and time
- Modify specifications of product or service being sought
- Attachment of vendor questions and responses
- Attachment of pre-bid sign-in sheet
- Correction of error
- Other

**Description of Modification to Solicitation:**

1. To send out required forms for the solicitation.
2. To provide Addendum Acknowledgement form.

**Additional Documentation:** Documentation related to this Addendum (if any) has been included herewith as Attachment A and is specifically incorporated herein by reference.

**Terms and Conditions:**

1. All provisions of the Solicitation and other addenda not modified herein shall remain in full force and effect.
2. Vendor should acknowledge receipt of all addenda issued for this Solicitation by completing an Addendum Acknowledgment, a copy of which is included herewith. Failure to acknowledge addenda may result in bid disqualification. The addendum acknowledgement should be submitted with the bid to expedite document processing.

ATTACHMENT A

**INSTRUCTIONS TO VENDORS SUBMITTING BIDS**

1. **REVIEW DOCUMENTS THOROUGHLY:** The attached documents contain a solicitation for bids. Please read these instructions and all documents attached in their entirety. These instructions provide critical information about requirements that if overlooked could lead to disqualification of a Vendor's bid. All bids must be submitted in accordance with the provisions contained in these instructions and the Solicitation. Failure to do so may result in disqualification of Vendor's bid.
2. **MANDATORY TERMS:** The Solicitation may contain mandatory provisions identified by the use of the words "must," "will," and "shall." Failure to comply with a mandatory term in the Solicitation will result in bid disqualification.
3. **PREBID MEETING:** The item identified below shall apply to this Solicitation.
  - A pre-bid meeting will not be held prior to bid opening.
  - A **NON-MANDATORY PRE-BID** meeting will be held at the following place and time:

- A **MANDATORY PRE-BID** meeting will be held at the following place and time:

Room # - AD 1 Training Room  
 150 Hopemont Drive  
 Terra Alta, WV 26764

November 19, 2013 - Tuesday @ 11 A.M.

All Vendors submitting a bid must attend the mandatory pre-bid meeting. Failure to attend the mandatory pre-bid meeting shall result in disqualification of the Vendor's bid. No one person attending the pre-bid meeting may represent more than one Vendor.

An attendance sheet provided at the pre-bid meeting shall serve as the official document verifying attendance. The State will not accept any other form of proof or documentation to verify attendance. Any person attending the pre-bid meeting on behalf of a Vendor must list on the attendance sheet his or her name and the name of the Vendor he or she is representing. Additionally, the person attending the pre-bid meeting should include the Vendor's E-Mail address, phone number, and Fax number on the attendance sheet. It is the Vendor's responsibility to locate the attendance sheet and provide the required information. Failure to complete the attendance sheet as required may result in disqualification of Vendor's bid.



State of West Virginia

## **PURCHASING DIVISION**

### **Construction Bid Submission Review Form**

*This list has been provided for informational purposes only and is not to be construed as a complete list of request for quotation or bidding requirements for any individual construction project. This list does not and cannot include every item, mistake or oversight that could cause a contractor's bid to be disqualified. Rather, this list is intended to draw attention to some of the most common problems that the Purchasing Division encounters in the bidding process for construction projects. All potential bidders must read the request for quotation, all additional documents, and all instructions relating thereto ("Bid Documents") in their entirety to identify the actual request for quotation and bidding requirements. Failure to read the Bid Documents in their entirety and comply with the stated requirements contained therein may result in bid disqualification.*

#### **Errors That Shall Be Reason for Immediate Bid Disqualification**

1. Failure to attend a mandatory pre-bid meeting
2. Failure to sign the bid
3. Failure to supply West Virginia contractor's license # on bid
4. Failure to supply a signed drug free workplace affidavit with the bid
5. Failure to supply a valid bid bond or other surety approved by the State of West Virginia
6. Failure to meet any mandatory requirement of the RFQ
7. Failure to acknowledge receipt of Addenda (only if stipulated as mandatory)
8. Failure to submit bid prior to the bid opening date and time
9. Federal debarment
10. State of West Virginia debarment or suspension

#### **Errors that May Be Reason for Bid Disqualification Before Contract Award**

1. Uncontested debt to the State exceeding \$1,000.00 (must be cured prior to award)
2. Workers' Compensation or Unemployment Compensation delinquency (must be cured prior to award)
3. Not registered as a vendor with the State (must be cured prior to award)
4. Failure to obtain required bonds and/or insurance
5. Failure to provide the sub-contractor listing within 1 business day of bid opening.
6. Failure to use the provided RFQ form (only if stipulated as mandatory).

**ADDENDUM ACKNOWLEDGEMENT FORM**  
**SOLICITATION NO.: HOP14103**

**Instructions:** Please acknowledge receipt of all addenda issued with this solicitation by completing this addendum acknowledgment form. Check the box next to each addendum received and sign below. Failure to acknowledge addenda may result in bid disqualification.

**Acknowledgment:** I hereby acknowledge receipt of the following addenda and have made the necessary revisions to my proposal, plans and/or specification, etc.

**Addendum Numbers Received:**

(Check the box next to each addendum received)

- |  |  |
|--|--|
| <input checked="" type="checkbox"/> Addendum No. 1 | <input type="checkbox"/> Addendum No. 6  |
| <input type="checkbox"/> Addendum No. 2            | <input type="checkbox"/> Addendum No. 7  |
| <input type="checkbox"/> Addendum No. 3            | <input type="checkbox"/> Addendum No. 8  |
| <input type="checkbox"/> Addendum No. 4            | <input type="checkbox"/> Addendum No. 9  |
| <input type="checkbox"/> Addendum No. 5            | <input type="checkbox"/> Addendum No. 10 |

I understand that failure to confirm the receipt of addenda may be cause for rejection of this bid. I further understand that any verbal representation made or assumed to be made during any oral discussion held between Vendor's representatives and any state personnel is not binding. Only the information issued in writing and added to the specifications by an official addendum is binding.

CTMCO INC  
Company

Jeff Gillenwater  
Authorized Signature

12-11-13  
Date



State of West Virginia  
 Department of Administration  
 Purchasing Division  
 2019 Washington Street East  
 Post Office Box 50130  
 Charleston, WV 25305-0130

**Solicitation**

NUMBER
HOP14103

PAGE
1

ADDRESS CORRESPONDENCE TO ATTENTION OF
ROBERTA WAGNER
304-558-0067

RFQ COPY

TYPE NAME/ADDRESS HERE

V  
E  
N  
D  
O  
R

Lee Brown  
 CIMCO, Inc.  
 2736 Virginia Ave.  
 Hurricane, WV 25526

S  
H  
I  
P  
T  
O

HEALTH AND HUMAN RESOURCES  
 HOPEMONT HOSPITAL  
 CENTRAL RECEIVING  
 150 HOPEMONT DRIVE  
 TERRA ALTA, WV  
 26764-7728 304-789-2411



DATE PRINTED
11/25/2013

BID OPENING DATE: 12/11/2013

BID OPENING TIME 1:30PM

LINE	QUANTITY	UOP	CAT. NO.	ITEM NUMBER	UNIT PRICE	AMOUNT
ADDENDUM NO. 2						
ADDENDUM IS ISSUED:						
1. TO PROVIDE A COPY OF THE PRE-BID MEETING SIGN-IN SHEET FOR THE ABOVE SOLICITATION.						
2. TO PROVIDE RESPONSES TO VENDORS' QUESTIONS REGARDING THE ABOVE SOLICITATION. QUESTION AND ANSWER PAGES ARE ATTACHED.						
3. TO PROVIDE ADDENDUM ACKNOWLEDGEMENT. THIS DOCUMENT SHOULD BE SIGNED AND RETURNED WITH YOUR BID. FAILURE TO SIGN AND RETURN MAY RESULT IN THE DISQUALIFICATION OF YOUR BID.						
***** END OF ADDENDUM NO.2 *****						

SIGNATURE <i>Jeff Hillman</i>	TELEPHONE 304-562-7705	DATE 12-11-13
TITLE Service Manager	FEIN 55-0749511	ADDRESS CHANGES TO BE NOTED ABOVE

WHEN RESPONDING TO SOLICITATION, INSERT NAME AND ADDRESS IN SPACE ABOVE LABELED 'VENDOR'



**SOLICITATION NUMBER: HOP14103**  
**Addendum Number: 2**

---

The purpose of this addendum is to modify the solicitation identified as (“Solicitation”) to reflect the change(s) identified and described below.

**Applicable Addendum Category:**

- Modify bid opening date and time
- Modify specifications of product or service being sought
- Attachment of vendor questions and responses
- Attachment of pre-bid sign-in sheet
- Correction of error
- Other

**Description of Modification to Solicitation:**

1. To provide copy of the pre-bid meeting sign-in sheet.
2. To provide copy of vendor questions and responses.
3. To provide Addendum Acknowledgement form.

**Additional Documentation:** Documentation related to this Addendum (if any) has been included herewith as Attachment A and is specifically incorporated herein by reference.

**Terms and Conditions:**

1. All provisions of the Solicitation and other addenda not modified herein shall remain in full force and effect.
2. Vendor should acknowledge receipt of all addenda issued for this Solicitation by completing an Addendum Acknowledgment, a copy of which is included herewith. Failure to acknowledge addenda may result in bid disqualification. The addendum acknowledgement should be submitted with the bid to expedite document processing.

# ATTACHMENT A

**SIGN IN SHEET**

Page 1 of 2

Request for Proposal No. HOP/4103

PLEASE PRINT

Date: 11/19/13

\* PLEASE BE SURE TO PRINT LEGIBLY - IF POSSIBLE, LEAVE A BUSINESS CARD

FIRM & REPRESENTATIVE NAME	MAILING ADDRESS	TELEPHONE & FAX NUMBERS
Company: <u>H.E. NEUMANN</u>	<u>1100 Grafton Rd.</u>	PHONE <u>304-292-5462</u>
Rep: <u>Chris Stone</u>	<u>Morgantown WV 26508</u>	TOLL FREE
Email Address: <u>stone@heneumann-co.com / stone@heneumann.com</u>		FAX <u>304-292-9259</u>
Company: <u>CIMCO INC</u>	<u>2336 VIRGINIA AVE</u>	PHONE <u>304-562-7705</u>
Rep: <u>LEE BROWN</u>	<u>HURRICANE WV 26526</u>	TOLL FREE <u>304-397-41</u>
Email Address: <u>LBROWN@CIMCO.COM</u>		FAX <u>304-397-4178</u>
Company: <u>MON VALLEY ELECTRIC</u>	<u>PO Box 338</u>	PHONE <u>304-366-2340</u>
Rep: <u>CHRIS RUSH</u>	<u>KINGMONT, WV 26578</u>	TOLL FREE
Email Address: <u>MVE@CHRIS@FRONTIER.COM</u>		FAX <u>304-366-2342</u>

**CIMCO INC.**

BUILDING SERVICES DIVISION

**Lee Brown**

ENERGY MANAGEMENT SPECIALIST

Office: 304.562.7705 Fax: 304.562.0320 Cell: 304.552.5257  
 Billing: PO Box 480, Culloden, WV 25510  
 Office/Shipping: 2336 Virginia Ave, Hurricane, WV 25526  
 Email: service@cimco.com | WV Contractor License WV025512



**Mon Valley Electric, Inc.**

P.O. Box 338  
 KINGMONT, WV 26578  
 PHONE: 304-366-2340  
 CELL: 304-534-2228  
 FAX: 304-366-2342

**CHRIS RUSH**

VICE PRESIDENT  
 EMAIL: MVE.CHRIS@FRONTIER.COM

PHONE  
 TOLL  
 FREE

FAX

PHONE  
 TOLL  
 FREE

FAX

SIGN IN SHEET

Request for Proposal No. HOP 14103

PLEASE PRINT

Page 2 of 2

Date: 11/19/13

\* PLEASE BE SURE TO PRINT LEGIBLY - IF POSSIBLE, LEAVE A BUSINESS CARD

FIRM & REPRESENTATIVE NAME	MAILING ADDRESS	TELEPHONE & FAX NUMBERS
Company: _____	_____	PHONE _____
Rep: _____	_____	TOLL _____
_____	_____	FREE _____
Email Address: _____	_____	FAX _____
Company: _____	_____	PHONE _____
Rep: _____	_____	TOLL _____
_____	_____	FREE _____
Email Address: _____	_____	FAX _____
Company: _____	_____	PHONE _____
Rep: _____	_____	TOLL _____
_____	_____	FREE _____
Email Address: _____	_____	FAX _____
Company: _____	_____	PHONE _____
Rep: _____	_____	TOLL _____
_____	_____	FREE _____
Email Address: _____	_____	FAX _____

**HOP14103-ADDENDUM#2**  
**Replace One Intermediate Cast Iron Section on M/N3500 Boiler**  
**Replace Control Panel for Gas Fired Boiler system in Units Building**

**Question #1:** We are considering submitting a proposal for the Boiler replacement project at Hopemont. Will drawings be available at the pre-bid tomorrow?

**Answer:** Drawings in question are on pages 25, 26 and 27 of the Bid Packet, this was acceptable to the vendors present.

**Question #2:** I would like to know if there is a budget or cost estimate available for the Hopemont Hospital Intermediate Cast Iron Section Replacement Project, just so I can get a better idea of how big this project is. If not, can you just give me a ballpark this project would fall under?

**Answer:** No, we can't divulge the budget amount for this project, nor can we give a ballpark figure.

**Question #3:** We will not know if the 8 sensors are working until the new control panel is installed, are we to include replacing sensors in the bid?

**Answer:** Yes, we will want any non- functioning sensors to be replaced when the control panel is installed, otherwise the control panel would not give us the functionality that is required.

**Question #4:** Do you want all the drawings/schematics/manuals left on the job site?

**Answer:** Yes, all documentation related to the boiler section replacement and the control panel replacement is to be left with Hopemont Hospital Maintenance Supervisor.

**Question #5:** 45 days will not be enough time to complete the job, the control panel is custom built and the weather will be a factor, can we extend the job from 45 days to 90 days?

**Answer:** Yes, that is acceptable to Hopemont to extent the job to 90 calendar days.

**ADDENDUM ACKNOWLEDGEMENT FORM**  
**SOLICITATION NO.: HOP14103**

**Instructions:** Please acknowledge receipt of all addenda issued with this solicitation by completing this addendum acknowledgment form. Check the box next to each addendum received and sign below. Failure to acknowledge addenda may result in bid disqualification.

**Acknowledgment:** I hereby acknowledge receipt of the following addenda and have made the necessary revisions to my proposal, plans and/or specification, etc.

**Addendum Numbers Received:**

(Check the box next to each addendum received)

- |  |  |
|--|--|
| <input type="checkbox"/> Addendum No. 1            | <input type="checkbox"/> Addendum No. 6  |
| <input checked="" type="checkbox"/> Addendum No. 2 | <input type="checkbox"/> Addendum No. 7  |
| <input type="checkbox"/> Addendum No. 3            | <input type="checkbox"/> Addendum No. 8  |
| <input type="checkbox"/> Addendum No. 4            | <input type="checkbox"/> Addendum No. 9  |
| <input type="checkbox"/> Addendum No. 5            | <input type="checkbox"/> Addendum No. 10 |

I understand that failure to confirm the receipt of addenda may be cause for rejection of this bid. I further understand that any verbal representation made or assumed to be made during any oral discussion held between Vendor's representatives and any state personnel is not binding. Only the information issued in writing and added to the specifications by an official addendum is binding.

*CTMCO INC*

Company

*Jeff Miller*

Authorized Signature

*12-11-13*

Date

NOTE: This addendum acknowledgement should be submitted with the bid to expedite document processing.

**BID BOND**

KNOW ALL MEN BY THESE PRESENTS, That we, the undersigned, Cimco, Inc.  
of P.O. Box 480, Culloden, WV 25510, as Principal, and Travelers Casualty and Surety Company of  
America of 1 Tower Square, Hartford, CT 06183, a corporation organized and existing under the laws of the State of Connecticut with its principal office in the City of Hartford, as Surety, are held and firmly bound unto the State of West Virginia, as Oblige, in the penal sum of Five Percent of Total Amount Bid (\$ 5%) for the payment of which, well and truly to be made, we jointly and severally bind ourselves, our heirs, administrators, executors, successors and assigns.

The Condition of the above obligation is such that whereas the Principal has submitted to the Purchasing Section of the Department of Administration a certain bid or proposal, attached hereto and made a part hereof, to enter into a contract in writing for HOP14103: Repair two boilers at Hopemont Hospital, Terra Alta, WV

NOW THEREFORE,

- (a) If said bid shall be rejected, or
- (b) If said bid shall be accepted and the Principal shall enter into a contract in accordance with the bid or proposal attached hereto and shall furnish any other bonds and insurance required by the bid or proposal, and shall in all other respects perform the agreement created by the acceptance of said bid, then this obligation shall be null and void, otherwise this obligation shall remain in full force and effect. It is expressly understood and agreed that the liability of the Surety for any and all claims hereunder shall, in no event, exceed the penal amount of this obligation as herein stated.

The Surety, for the value received, hereby stipulates and agrees that the obligations of said Surety and its bond shall be in no way impaired or affected by any extension of the time within which the Oblige may accept such bid, and said Surety does hereby waive notice of any such extension.

IN WITNESS WHEREOF, Principal and Surety have hereunto set their hands and seals, and such of them as are corporations have caused their corporate seals to be affixed hereunto and these presents to be signed by their proper officers, this 11th day of December, 20 13.

Principal Corporate Seal

Cimco, Inc.

(Name of Principal)

By Mitchell Smith

(Must be President or Vice President)

PRESIDENT

(Title)

Surety Corporate Seal

Travelers Casualty and Surety Company of America

(Name of Surety)

Lepi Vustard Shwood  
Attorney-in-Fact

**IMPORTANT – Surety executing bonds must be licensed in West Virginia to transact surety insurance. Raised corporate seals must be affixed, a power of attorney must be attached.**



POWER OF ATTORNEY

Farmington Casualty Company
Fidelity and Guaranty Insurance Company
Fidelity and Guaranty Insurance Underwriters, Inc.
St. Paul Fire and Marine Insurance Company
St. Paul Guardian Insurance Company

St. Paul Mercury Insurance Company
Travelers Casualty and Surety Company
Travelers Casualty and Surety Company of America
United States Fidelity and Guaranty Company

Attorney-In Fact No. 218346

Certificate No. 005025845

KNOW ALL MEN BY THESE PRESENTS: That St. Paul Fire and Marine Insurance Company, St. Paul Guardian Insurance Company and St. Paul Mercury Insurance Company are corporations duly organized under the laws of the State of Minnesota, that Farmington Casualty Company, Travelers Casualty and Surety Company, and Travelers Casualty and Surety Company of America are corporations duly organized under the laws of the State of Connecticut, that United States Fidelity and Guaranty Company is a corporation duly organized under the laws of the State of Maryland, that Fidelity and Guaranty Insurance Company is a corporation duly organized under the laws of the State of Iowa, and that Fidelity and Guaranty Insurance Underwriters, Inc., is a corporation duly organized under the laws of the State of Wisconsin (herein collectively called the "Companies"), and that the Companies do hereby make, constitute and appoint

C. David Thomas, Richard L. Higginbotham, Bunnie Marie Perrine, Jeffery O'Dell, and Robin Hubbard-Sherrod

of the City of Charleston, State of West Virginia, their true and lawful Attorney(s)-in-Fact, each in their separate capacity if more than one is named above, to sign, execute, seal and acknowledge any and all bonds, recognizances, conditional undertakings and other writings obligatory in the nature thereof on behalf of the Companies in their business of guaranteeing the fidelity of persons, guaranteeing the performance of contracts and executing or guaranteeing bonds and undertakings required or permitted in any actions or proceedings allowed by law.

IN WITNESS WHEREOF, the Companies have caused this instrument to be signed and their corporate seals to be hereto affixed, this 6th day of September, 2012.

Farmington Casualty Company
Fidelity and Guaranty Insurance Company
Fidelity and Guaranty Insurance Underwriters, Inc.
St. Paul Fire and Marine Insurance Company
St. Paul Guardian Insurance Company

St. Paul Mercury Insurance Company
Travelers Casualty and Surety Company
Travelers Casualty and Surety Company of America
United States Fidelity and Guaranty Company



State of Connecticut
City of Hartford ss.

By: [Signature]
George W. Thompson, Senior Vice President

On this the 6th day of September, 2012, before me personally appeared George W. Thompson, who acknowledged himself to be the Senior Vice President of Farmington Casualty Company, Fidelity and Guaranty Insurance Company, Fidelity and Guaranty Insurance Underwriters, Inc., St. Paul Fire and Marine Insurance Company, St. Paul Guardian Insurance Company, St. Paul Mercury Insurance Company, Travelers Casualty and Surety Company, Travelers Casualty and Surety Company of America, and United States Fidelity and Guaranty Company, and that he, as such, being authorized so to do, executed the foregoing instrument for the purposes therein contained by signing on behalf of the corporations by himself as a duly authorized officer.

In Witness Whereof, I hereunto set my hand and official seal.
My Commission expires the 30th day of June, 2016.



[Signature]
Marie C. Tetreault, Notary Public



# CONTRACTOR LICENSE

Authorized by the

West Virginia Contractor Licensing Board

Number: WV025512

**Classification:**

HEATING, VENTILATING & COOLING  
PIPING  
PLUMBING

CIMCO INC  
DBA CIMCO INC  
PO BOX 480  
CULLODEN, WV 25510

**Date Issued**

MAY 09, 2013

**Expiration Date**

MAY 09, 2014

*Mitchell Smith*

Authorized Company Signature

*Michael A. Carl*

Chair, West Virginia Contractor  
Licensing Board

WEST VIRGINIA  
CONTRACTOR  
LICENSING  
BOARD

This license, or a copy thereof, must be posted in a conspicuous place at every construction site where work is being performed. This license number must appear in all advertisements, on all bid submissions and on all fully executed and binding contracts. This license cannot be assigned or transferred by licensee. Issued under provisions of West Virginia Code, Chapter 21, Article 11.



DATE (MM/DD/YYYY)

05/01/2013

# CERTIFICATE OF LIABILITY INSURANCE

THIS CERTIFICATE IS ISSUED AS A MATTER OF INFORMATION ONLY AND CONFERS NO RIGHTS UPON THE CERTIFICATE HOLDER. THIS CERTIFICATE DOES NOT AFFIRMATIVELY OR NEGATIVELY AMEND, EXTEND OR ALTER THE COVERAGE AFFORDED BY THE POLICIES BELOW. THIS CERTIFICATE OF INSURANCE DOES NOT CONSTITUTE A CONTRACT BETWEEN THE ISSUING INSURER(S), AUTHORIZED REPRESENTATIVE OR PRODUCER, AND THE CERTIFICATE HOLDER.

**IMPORTANT:** If the certificate holder is an ADDITIONAL INSURED, the policy(ies) must be endorsed. If SUBROGATION IS WAIVED, subject to the terms and conditions of the policy, certain policies may require an endorsement. A statement on this certificate does not confer rights to the certificate holder in lieu of such endorsement(s).

PRODUCER George H. Friedlander Co. PO Box 2466 1566 Kanawha Blvd. E. Charleston, WV 25311	Phone: 304-357-4520 Fax: 304-345-8724	CONTACT NAME: PHONE (A/C, No, Ext): 304-357-4520 FAX (A/C, No): 304-345-8724 E-MAIL ADDRESS: INSURER(S) AFFORDING COVERAGE INSURER A: Travelers Insurance INSURER B: INSURER C: INSURER D: INSURER E: INSURER F:	NAIC # 25674
INSURED Cimco, Inc. P O Box 480 Culloden, WV 25510-0480			

**COVERAGES**      **CERTIFICATE NUMBER:**      **REVISION NUMBER:**

THIS IS TO CERTIFY THAT THE POLICIES OF INSURANCE LISTED BELOW HAVE BEEN ISSUED TO THE INSURED NAMED ABOVE FOR THE POLICY PERIOD INDICATED. NOTWITHSTANDING ANY REQUIREMENT, TERM OR CONDITION OF ANY CONTRACT OR OTHER DOCUMENT WITH RESPECT TO WHICH THIS CERTIFICATE MAY BE ISSUED OR MAY PERTAIN, THE INSURANCE AFFORDED BY THE POLICIES DESCRIBED HEREIN IS SUBJECT TO ALL THE TERMS, EXCLUSIONS AND CONDITIONS OF SUCH POLICIES. LIMITS SHOWN MAY HAVE BEEN REDUCED BY PAID CLAIMS.

INSR LTR	TYPE OF INSURANCE	ADDL INSR	SUBR WVD	POLICY NUMBER	POLICY EFF (MM/DD/YYYY)	POLICY EXP (MM/DD/YYYY)	LIMITS
A	GENERAL LIABILITY <input checked="" type="checkbox"/> COMMERCIAL GENERAL LIABILITY <input type="checkbox"/> CLAIMS-MADE <input checked="" type="checkbox"/> OCCUR <input checked="" type="checkbox"/> Contractual Liab  GEN'L AGGREGATE LIMIT APPLIES PER: <input type="checkbox"/> POLICY <input type="checkbox"/> PRO-JECT <input type="checkbox"/> LOC			CO-5614B143-13	05/01/2013	05/01/2014	EACH OCCURRENCE \$ 1,000,000 DAMAGE TO RENTED PREMISES (Ea occurrence) \$ 300,000 MED EXP (Any one person) \$ 5,000 PERSONAL & ADV INJURY \$ 1,000,000 GENERAL AGGREGATE \$ 2,000,000 PRODUCTS - COMP/OP AGG \$ 2,000,000
A	AUTOMOBILE LIABILITY <input checked="" type="checkbox"/> ANY AUTO <input type="checkbox"/> ALL OWNED AUTOS <input checked="" type="checkbox"/> HIRED AUTOS <input type="checkbox"/> SCHEDULED AUTOS <input checked="" type="checkbox"/> NON-OWNED AUTOS			810-5614B143-13	05/01/2013	05/01/2014	COMBINED SINGLE LIMIT (Ea accident) \$ 1,000,000 BODILY INJURY (Per person) \$ BODILY INJURY (Per accident) \$ PROPERTY DAMAGE (Per accident) \$
A	<input checked="" type="checkbox"/> UMBRELLA LIAB <input checked="" type="checkbox"/> OCCUR <input type="checkbox"/> EXCESS LIAB <input type="checkbox"/> CLAIMS-MADE  DED    RETENTION \$			CUP-5614B143-13	05/01/2013	05/01/2014	EACH OCCURRENCE \$ 5,000,000 AGGREGATE \$ 5,000,000
A	WORKERS COMPENSATION AND EMPLOYERS' LIABILITY ANY PROPRIETOR/PARTNER/EXECUTIVE OFFICER/MEMBER EXCLUDED? (Mandatory in NH) If yes, describe under DESCRIPTION OF OPERATIONS below		N/A	UB-6557N779-13 INCL WV CODE ANNOT 23-4-2	05/01/2013	05/01/2014	<input checked="" type="checkbox"/> WC STATUTORY LIMITS    OTH-ER E.L. EACH ACCIDENT \$ 1,000,000 E.L. DISEASE - EA EMPLOYEE \$ 1,000,000 E.L. DISEASE - POLICY LIMIT \$ 1,000,000

DESCRIPTION OF OPERATIONS / LOCATIONS / VEHICLES (Attach ACORD 101, Additional Remarks Schedule, if more space is required)  
Evidence of insurance

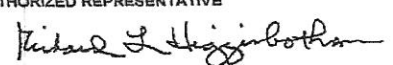
<b>CERTIFICATE HOLDER</b>  <b>TO WHOM IT MAY CONCERN</b>  BLAN002	<b>CANCELLATION</b>  SHOULD ANY OF THE ABOVE DESCRIBED POLICIES BE CANCELLED BEFORE THE EXPIRATION DATE THEREOF, NOTICE WILL BE DELIVERED IN ACCORDANCE WITH THE POLICY PROVISIONS.
	AUTHORIZED REPRESENTATIVE 



West Virginia Division of Labor  
PLUMBER LICENSE



License #  
**PL00326**

Classification  
**MASTER**

Expiration Date  
12/31/2014

Issued To:

**MITCHELL R SMITH**



**WV 25143**

(Authorized Signature)

Issued under the provision of West Virginia Code  
§21-14, Supervision of Plumbing Work.