

**Technical Proposal**  
**Solicitation Number EBA464**

**S & M Total Comfort, LLC**

**Bid Opening August 8, 2013**

**Bid Opening Time: 1:30p.m.**

08/08/13 01:17:56 PM  
West Virginia Purchasing Division



State of West Virginia  
 Department of Administration  
 Purchasing Division  
 2019 Washington Street East  
 Post Office Box 50130  
 Charleston, WV 25305-0130

**Solicitation**

NUMBER
EBA464

PAGE
1

ADDRESS CORRESPONDENCE TO ATTENTION OF:
CONNIE OSWALD 304-558-2157

VENDOR

RFQ COPY  
 TYPE NAME/ADDRESS HERE

SHIP TO

WSWP-TV  
 AIRPORT ROAD  
  
 BECKLEY, WV  
 25801 255-1501

DATE PRINTED
07/14/2013

BID OPENING DATE: 08/08/2013 BID OPENING TIME 01:30PM

LINE	QUANTITY	UCP	CAT. NO.	ITEM NUMBER	UNIT PRICE	AMOUNT
THE STATE OF WEST VIRGINIA AND ITS AGENCY THE WEST VIRGINIA EDUCATIONAL BROADCASTING AUTHORITY; WSWP-TV LOCATED AT 124 INDUSTRIAL PARK ROAD, BEAVER, WV 25813 REQUEST A QUOTE TO PROVIDE LABOR & MATERIALS TO INSTALL A ROOFTOP HVAC SYSTEM TRANE VOYAGER OR EQUAL PER THE ATTACHED SPECIFICATIONS AND INSTRUCTIONS TO BIDDERS.  MANDATORY PRE-BID: JULY 30, 2013 @ 10:30AM (SEE INSTRUCTIONS TO BIDDERS)  BID OPENING: AUGUST 8, 2013 AT 1:30PM						
0001	1	EA		031-03	\$24,000	\$31,200
				HVAC ROOFTOP SYSTEM TRANE VOYAGER (OR EQUAL)		
0002	1	LS		031-03	\$2,400	\$3,120
				LABOR TO INSTALL HVAC ROOFTOP SYSTEM AS NOTED ABOVE		

SIGNATURE	TELEPHONE 304-356-7407	DATE 8/8/2013
TITLE Owner	FEIN 46-2563811	ADDRESS CHANGES TO BE NOTED ABOVE

WHEN RESPONDING TO SOLICITATION, INSERT NAME AND ADDRESS IN SPACE ABOVE LABELED 'VENDOR'



State of West Virginia  
 Department of Administration  
 Purchasing Division  
 2019 Washington Street East  
 Post Office Box 50130  
 Charleston, WV 25305-0130

**Solicitation**

NUMBER
EBA464

PAGE
2

ADDRESS CORRESPONDENCE TO ATTENTION OF
CONNIE OSWALD 304-558-2157

VENDOR

RFQ COPY  
 TYPE NAME/ADDRESS HERE

SHIP TO

WSWP-TV  
 AIRPORT ROAD  
  
 BECKLEY, WV  
 25801 255-1501

DATE PRINTED
07/14/2013

BID OPENING DATE: 08/08/2013 BID OPENING TIME 01:30PM

LINE	QUANTITY	UOP	CAT. NO.	ITEM NUMBER	UNIT PRICE	AMOUNT
***** THIS IS THE END OF RFQ EBA464 ***** TOTAL:						\$34,320

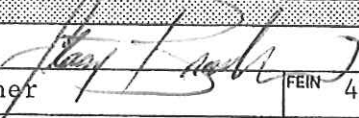
SIGNATURE 	TELEPHONE 304-356-7407	DATE 8/8/2013
TITLE Owner	FEIN 46-2563811	ADDRESS CHANGES TO BE NOTED ABOVE

WHEN RESPONDING TO SOLICITATION, INSERT NAME AND ADDRESS IN SPACE ABOVE LABELED 'VENDOR'

**ADDENDUM ACKNOWLEDGEMENT FORM**

**SOLICITATION NO.:** EBA464

**Instructions:** Please acknowledge receipt of all addenda issued with this solicitation by completing this addendum acknowledgment form. Check the box next to each addendum received and sign below. Failure to acknowledge addenda may result in bid disqualification.

**Acknowledgment:** I hereby acknowledge receipt of the following addenda and have made the necessary revisions to my proposal, plans and/or specification, etc.

**Addendum Numbers Received:**

(Check the box next to each addendum received)

- |  |  |
|--|--|
| <input checked="" type="checkbox"/> ] Addendum No. 1 | <input type="checkbox"/> ] Addendum No. 6  |
| <input checked="" type="checkbox"/> ] Addendum No. 2 | <input type="checkbox"/> ] Addendum No. 7  |
| <input type="checkbox"/> ] Addendum No. 3            | <input type="checkbox"/> ] Addendum No. 8  |
| <input type="checkbox"/> ] Addendum No. 4            | <input type="checkbox"/> ] Addendum No. 9  |
| <input type="checkbox"/> ] Addendum No. 5            | <input type="checkbox"/> ] Addendum No. 10 |

I understand that failure to confirm the receipt of addenda may be cause for rejection of this bid. I further understand that any verbal representation made or assumed to be made during any oral discussion held between Vendor's representatives and any state personnel is not binding. Only the information issued in writing and added to the specifications by an official addendum is binding.

S&M Total Comfort LLC

Company

Authorized Signature

8/8/2013

Date

NOTE: This addendum acknowledgment should be submitted with the bid to expedite document processing.



State of West Virginia  
 Department of Administration  
 Purchasing Division  
 2019 Washington Street East  
 Post Office Box 50130  
 Charleston, WV 25305-0130

**Solicitation**

NUMBER
EBA464

PAGE
1

ADDRESS CORRESPONDENCE TO ATTENTION OF:
CONNIE OSWALD
304-558-2157

RFQ COPY  
 TYPE NAME/ADDRESS HERE

V E N D O R
----------------------------

S H I P T O
WSWP-TV
AIRPORT ROAD
BECKLEY, WV
25801
255-1501

DATE PRINTED
07/25/2013

BID OPENING DATE: 08/08/2013 BID OPENING TIME 1:30PM

LINE	QUANTITY	UOP	CAT. NO.	ITEM NUMBER	UNIT PRICE	AMOUNT
ADDENDUM NO. 1						
1.				TO CLARIFY AND CONFIRM THE MANDATORY PRE-BID MEETING SCHEDULED FOR JULY 30, 2013 AT 10:30 AM, PREVIOUSLY LISTED IN THE PURCHASING BULLETIN IN ERROR. LOCATION HAS NOT CHANGED.		
2.				TO PROVIDE THE ADDENDUM ACKNOWLEDGMENT. THIS DOCUMENT SHOULD BE SIGNED AND RETURNED WITH YOUR BID. FAILURE TO SIGN AND RETURN MAY RESULT IN DISQUALIFICATION OF YOUR BID.		
END OF ADDENDUM NO. 1						

SIGNATURE	TELEPHONE 304-356-7407	DATE 8/8/2013
TITLE Owner	FEN 46-2563811	ADDRESS CHANGES TO BE NOTED ABOVE

WHEN RESPONDING TO SOLICITATION, INSERT NAME AND ADDRESS IN SPACE ABOVE LABELED 'VENDOR'



State of West Virginia  
 Department of Administration  
 Purchasing Division  
 2019 Washington Street East  
 Post Office Box 50130  
 Charleston, WV 25305-0130

### Solicitation

NUMBER
EBA464

PAGE
1

ADDRESS CORRESPONDENCE TO ATTENTION OF:
CONNIE OSWALD 304-558-2157

VENDOR

RFQ COPY  
 TYPE NAME/ADDRESS HERE

SHIP TO

WSWP-TV  
 AIRPORT ROAD  
 BECKLEY, WV  
 25801 255-1501

DATE PRINTED
08/02/2013

BID OPENING DATE: 08/08/2013 BID OPENING TIME 1:30PM

LINE	QUANTITY	UOP	CAT. NO.	ITEM NUMBER	UNIT PRICE	AMOUNT
ADDENDUM NO. 2						
1.				TO PROVIDE ANSWERS TO QUESTIONS RECEIVED FOR THIS SOLICITATION.		
2.				TO PROVIDE THE MANDATORY PRE-BID SIGN IN SHEETS.		
3.				TO PROVIDE THE ADDENDUM ACKNOWLEDGMENT. THIS DOCUMENT SHOULD BE SIGNED AND RETURNED WITH BID, FAILURE TO SIGN AND RETURN MAY RESULT IN DISQUALIFICATION OF YOUR BID.		
END OF ADDENDUM NO. 2						

SIGNATURE	TELEPHONE 304-356-7407	DATE 8/8/2013
TITLE <i>Owner</i>	FAX 46-2563811	ADDRESS CHANGES TO BE NOTED ABOVE

WHEN RESPONDING TO SOLICITATION, INSERT NAME AND ADDRESS IN SPACE ABOVE LABELED 'VENDOR'

# Technical Proposal

## S & M Total Comfort, LLC.

### General Requirements

**3.1-S & M Total Comfort, LLC** agrees to provide all necessary requirements to fulfill this solicitation # EBA464.

**3.1.1 S & M Total Comfort, LLC** will install a turn-key rooftop packaged HVAC system with a cooling rating of 25 ton BTU and a minimum heating capacity exceeding the basic requirements of 36KW to supply 54KW.

**3.1.1.1 S & M Total Comfort, LLC** will provide a new HVAC system the American Standard which is equivalent to the Trane Voyager with the following features:

- a. Economizer system
- b. Low ambient kit
- c. Dual Compressor
- d. 208 volts/3phase power
- e. Filter units shall be in an easily accessible location and accept readily available, standard sized filters.

**3.1.1.2 S & M Total Comfort, LLC** will install the new unit on a newly built curb and will physically sit on the roof directly above the existing duct work from the old unit.

**3.1.1.3 S & M Total Comfort, LLC** will be responsible for connecting new drain lines to existing drain system.

**3.1.1.4 S & M Total Comfort, LLC** will test for water leaks after installation around the unit and curb and repair any leaks if necessary.

**3.1.1.5 S & M Total Comfort, LLC** will furnish and install the new programmable thermostat for the new HVAC unit. If found that the control wiring needs to be replaced, S & M Total Comfort, LLC will replace.

**3.1.1.6 S & M Total Comfort, LLC** will provide an electrical disconnect at the rating of 130 Amp mounted within sight of the outside units to allow positive disconnect during servicing.

**3.1.1.7 S & M Total Comfort, LLC** will provide all exterior electricity, both power and control, will be installed using water-tight connections and enclosures.

**3.1.1.8** S & M Total Comfort, LLC will ensure that all exterior hardware will be galvanized.

**3.1.1.9** S & M Total Comfort, LLC will connect the new HVAC unit to connect and function with the current fire alarm system Edwards model 5721.

**3.1.1.10** S & M Total Comfort, LLC will tie the new HVAC system into and utilize the existing air supply and return air ducts located in the studio ceiling and scene shop areas.

**3.1.1.11** S & M Total Comfort, LLC will reconnect the branch duct to the studio lighting dimming cabinet room.

**3.1.1.12** S & M Total Comfort, LLC will install a new duct smoke detector and will be tied into fire alarm panel.

**3.1.1.13** Upon completion S & M Total Comfort, LLC will provide full documentation of installation with particular emphasis on the control wiring and power distribution.

**3.1.1.14** S & M Total Comfort, LLC was at the pre-bid and inspected the conditions and the work required. No allowance will be made on behalf of S & M Total Comfort, LLC for any error or negligence on their part in connection with this requirement.

### **Schedule of Work**

Weather permitting, S & M Total Comfort, LLC plans to provide all work described above to take approximately four business days. Outlining the basics of what is to be completed each day.

Day 1: Roof penetration, run electric and curb construction (Roof cuts will be made by warranty contractor Boggs Roofing, Inc.)

Day 2: Crane set up, set unit, Plenum construction

Day 3: Install smoke detectors, thermostat and all controls. Tie in duct work.

Day 4: Finish duct work, check for leaks, roof flashing, system start up and test.

Upon completion of installation, S & M Total Comfort, LLC will provide complete documentation of installation with emphasis of control wiring and power distribution.



S & M Total Comfort, LLC abides by West Virginia Code 21-1D-7b pertaining to a Drug-Free Workplace.

A handwritten signature in black ink, appearing to read "Steve Paul", written over a horizontal line. The signature is cursive and stylized.

Signature

# CONTRACTOR LICENSE

Authorized by the  
West Virginia Contractor Licensing Board

Number: WV050844

Classification:

SHEET METAL  
INSULATION

S&M TOTAL COMFORT LLC  
DBA S&M TOTAL COMFORT LLC  
124 ALLEN CT  
TORNADO, WV 25202

Date Issued

MAY 06, 2013

Expiration Date

MAY 06, 2014

Authorized Company Signature

*Michael A. Carl*

Chair, West Virginia Contractor  
Licensing Board

WEST VIRGINIA  
CONTRACTOR  
LICENSING  
BOARD

This license, or a copy thereof, must be posted in a conspicuous place at every construction site where work is being performed. This license number must appear in all advertisements, on all bid submissions and on all fully executed and binding contracts. This license cannot be assigned or transferred by licensee. Issued under provisions of West Virginia Code, Chapter 21, Article 11.



# CERTIFICATE OF LIABILITY INSURANCE

DATE (MM/DD/YYYY)

06/18/2013

THIS CERTIFICATE IS ISSUED AS A MATTER OF INFORMATION ONLY AND CONFERS NO RIGHTS UPON THE CERTIFICATE HOLDER. THIS CERTIFICATE DOES NOT AFFIRMATIVELY OR NEGATIVELY AMEND, EXTEND OR ALTER THE COVERAGE AFFORDED BY THE POLICIES BELOW. THIS CERTIFICATE OF INSURANCE DOES NOT CONSTITUTE A CONTRACT BETWEEN THE ISSUING INSURER(S), AUTHORIZED REPRESENTATIVE OR PRODUCER, AND THE CERTIFICATE HOLDER.

**IMPORTANT:** If the certificate holder is an ADDITIONAL INSURED, the policy(ies) must be endorsed. If SUBROGATION IS WAIVED, subject to the terms and conditions of the policy, certain policies may require an endorsement. A statement on this certificate does not confer rights to the certificate holder in lieu of such endorsement(s).

<b>PRODUCER</b> Garlow Insurance Agency, Inc. 1217 Quarrier Street  Charleston, WV 25301	<b>CONTACT NAME:</b> PHONE (A/C, No, Ext): (304)347-8972	FAX (A/C, No): (304)347-8973
	<b>E-MAIL ADDRESS:</b>	
<b>INSURED</b> S&M Total Comfort LLC Stacy Branham 124 Allen Ct Tornado, WV 25202	<b>INSURER(S) AFFORDING COVERAGE</b>	
	<b>INSURER A:</b> Erie Insurance	
	<b>INSURER B:</b>	
	<b>INSURER C:</b>	
	<b>INSURER D:</b>	
	<b>INSURER E:</b>	
<b>INSURER F:</b>		

**COVERAGES**

CERTIFICATE NUMBER:

REVISION NUMBER:

THIS IS TO CERTIFY THAT THE POLICIES OF INSURANCE LISTED BELOW HAVE BEEN ISSUED TO THE INSURED NAMED ABOVE FOR THE POLICY PERIOD INDICATED. NOTWITHSTANDING ANY REQUIREMENT, TERM OR CONDITION OF ANY CONTRACT OR OTHER DOCUMENT WITH RESPECT TO WHICH THIS CERTIFICATE MAY BE ISSUED OR MAY PERTAIN, THE INSURANCE AFFORDED BY THE POLICIES DESCRIBED HEREIN IS SUBJECT TO ALL THE TERMS, EXCLUSIONS AND CONDITIONS OF SUCH POLICIES. LIMITS SHOWN MAY HAVE BEEN REDUCED BY PAID CLAIMS.

INSR LTR	TYPE OF INSURANCE	ADDL SUBR INSR   WVD	POLICY NUMBER	POLICY EFF (MM/DD/YYYY)	POLICY EXP (MM/DD/YYYY)	LIMITS	
A	<b>GENERAL LIABILITY</b> <input type="checkbox"/> COMMERCIAL GENERAL LIABILITY <input type="checkbox"/> CLAIMS-MADE <input checked="" type="checkbox"/> OCCUR  GEN'L AGGREGATE LIMIT APPLIES PER: <input checked="" type="checkbox"/> POLICY <input type="checkbox"/> PRO-JECT <input type="checkbox"/> LOC		Q306820115	6/18/2013	6/18/2014	EACH OCCURRENCE	\$ 1,000,000
						DAMAGE TO RENTED PREMISES (Ea occurrence)	\$ 1,000,000
						MED EXP (Any one person)	\$ 5,000
						PERSONAL & ADV INJURY	\$ 1,000,000
						GENERAL AGGREGATE	\$ 2,000,000
						PRODUCTS - COMP/OP AGG	\$ 2,000,000
							\$
	<b>AUTOMOBILE LIABILITY</b> <input type="checkbox"/> ANY AUTO <input type="checkbox"/> ALL OWNED AUTOS <input type="checkbox"/> HIRED AUTOS <input type="checkbox"/> SCHEDULED AUTOS <input type="checkbox"/> NON-OWNED AUTOS					COMBINED SINGLE LIMIT (Ea accident)	\$
						BODILY INJURY (Per person)	\$
						BODILY INJURY (Per accident)	\$
						PROPERTY DAMAGE (Per accident)	\$
							\$
	<b>UMBRELLA LIAB</b> <input type="checkbox"/> OCCUR <b>EXCESS LIAB</b> <input type="checkbox"/> CLAIMS-MADE  DED RETENTION \$					EACH OCCURRENCE	\$
						AGGREGATE	\$
							\$
	<b>WORKERS COMPENSATION AND EMPLOYERS' LIABILITY</b> ANY PROPRIETOR/PARTNER/EXECUTIVE OFFICER/MEMBER EXCLUDED? (Mandatory in NH) If yes, describe under DESCRIPTION OF OPERATIONS below	Y/N	N/A			WC STATUTORY LIMITS	OTHER
						E.L. EACH ACCIDENT	\$
						E.L. DISEASE - EA EMPLOYEE	\$
						E.L. DISEASE - POLICY LIMIT	\$

DESCRIPTION OF OPERATIONS / LOCATIONS / VEHICLES (Attach ACORD 101, Additional Remarks Schedule, If more space is required)

Contractors Enhancement Endorsement

**CERTIFICATE HOLDER**

Proof of coverage

**CANCELLATION**

SHOULD ANY OF THE ABOVE DESCRIBED POLICIES BE CANCELLED BEFORE THE EXPIRATION DATE THEREOF, NOTICE WILL BE DELIVERED IN ACCORDANCE WITH THE POLICY PROVISIONS.

AUTHORIZED REPRESENTATIVE

© 1988-2010 ACORD CORPORATION. All rights reserved.



# S&M TOTAL COMFORT, LLC

A Small, Service Disabled Veteran Owned Company

Tel: (304) 356-7407

## Capability Statement

S & M Total Comfort, LLC is a reliable company that has the expertise in all facets of construction. With 20 years of experience, owner Stacy Branham is a Service Disabled Veteran possessing Active Secret Security Clearance.

### Past Performances Include:

- ⇒ FBI Chiller Project
- ⇒ Ground Zero 9/11 Generator Projects
- ⇒ The Navel Research Chiller Project
- ⇒ The Project Manager for Facility Maintenance for the WV Military Authority.

### Primary NAICS Codes

- 238220-Plumbing, Heating & Air-Conditioning
- 238910-Demolition
- 237310-Asphalt
- 236220-Construction
- 238210-Electrical
- 238990-Concrete



EIN # 462563811

DUNS # 078868091

S & M Total Comfort LLC

Tornado, West Virginia

Phone: (304) 356-7407

Fax: (304)722-5899

Email: [smtotalcomfort@gmail.com](mailto:smtotalcomfort@gmail.com)



### Certifications

Universal CFC's/EPA  
600 Volt/4160 Electrical Certification  
Cryogenic Specialist/Piping & Technical Support  
Industrial HVAC Specialist  
Med Gas Brazing & Piping Certified

**Cost Proposal**

**Solicitation Number EBA464**

**S & M Total Comfort, LLC**

**Bid Opening August 8, 2013**

**Bid Opening Time: 1:30p.m.**



State of West Virginia  
 Department of Administration  
 Purchasing Division  
 2019 Washington Street East  
 Post Office Box 50130  
 Charleston, WV 25305-0130

**Solicitation**

NUMBER
EBA464

PAGE
1

ADDRESS CORRESPONDENCE TO ATTENTION OF:
CONNIE OSWALD 304-558-2157

VENDOR

RFQ COPY  
 TYPE NAME/ADDRESS HERE

SHIP TO

WSWP-TV  
 AIRPORT ROAD  
  
 BECKLEY, WV  
 25801 255-1501

DATE PRINTED
07/14/2013

BID OPENING DATE: 08/08/2013 BID OPENING TIME 01:30PM

LINE	QUANTITY	UOP	CAT. NO.	ITEM NUMBER	UNIT PRICE	AMOUNT
THE STATE OF WEST VIRGINIA AND ITS AGENCY THE WEST VIRGINIA EDUCATIONAL BROADCASTING AUTHORITY; WSWP-TV LOCATED AT 124 INDUSTRIAL PARK ROAD, BEAVER, WV 25813 REQUEST A QUOTE TO PROVIDE LABOR & MATERIALS TO INSTALL A ROOFTOP HVAC SYSTEM TRANE VOYAGER OR EQUAL PER THE ATTACHED SPECIFICATIONS AND INSTRUCTIONS TO BIDDERS.  MANDATORY PRE-BID: JULY 30, 2013 @ 10:30AM (SEE INSTRUCTIONS TO BIDDERS)  BID OPENING: AUGUST 8, 2013 AT 1:30PM						
0001	1	EA		031-03	\$24,000	\$31,200
HVAC ROOFTOP SYSTEM TRANE VOYAGER (OR EQUAL)						
0002	1	LS		031-03	\$2,400	\$3,120
LABOR TO INSTALL HVAC ROOFTOP SYSTEM AS NOTED ABOVE						

SIGNATURE	TELEPHONE 304-356-7407	DATE 8/8/2013
TITLE Owner	FEIN 46-2563811	ADDRESS CHANGES TO BE NOTED ABOVE

WHEN RESPONDING TO SOLICITATION, INSERT NAME AND ADDRESS IN SPACE ABOVE LABELED 'VENDOR'



State of West Virginia  
 Department of Administration  
 Purchasing Division  
 2019 Washington Street East  
 Post Office Box 50130  
 Charleston, WV 25305-0130

**Solicitation**

NUMBER  
**EBA464**

PAGE  
**2**

ADDRESS CORRESPONDENCE TO ATTENTION OF:  
**CONNIE OSWALD**  
**304-558-2157**

VENDOR

RFQ COPY  
 TYPE NAME/ADDRESS HERE

SHIP TO

**WSWP-TV**  
**AIRPORT ROAD**  
  
**BECKLEY, WV**  
**25801**                      **255-1501**

DATE PRINTED  
**07/14/2013**

BID OPENING DATE: **08/08/2013**                      **BID OPENING TIME 01:30PM**

LINE	QUANTITY	UOP	CAT NO	ITEM NUMBER	UNIT PRICE	AMOUNT
***** THIS IS THE END OF RFQ                      EBA464 ***** TOTAL:						\$34,320

SIGNATURE: *[Signature]*                      TELEPHONE: 304-356-7407                      DATE: 8/8/2013  
 TITLE: Owner                      FEIN: 46-2563811

ADDRESS CHANGES TO BE NOTED ABOVE

WHEN RESPONDING TO SOLICITATION, INSERT NAME AND ADDRESS IN SPACE ABOVE LABELED 'VENDOR'



The bid should contain the information listed below on the face of the envelope or the bid may not be considered:

SEALED BID

BUYER: \_\_\_\_\_  
SOLICITATION NO.: \_\_\_\_\_  
BID OPENING DATE: \_\_\_\_\_  
BID OPENING TIME: \_\_\_\_\_  
FAX NUMBER: \_\_\_\_\_

In the event that Vendor is responding to a request for proposal, the Vendor shall submit one original technical and one original cost proposal plus  convenience copies of each to the Purchasing Division at the address shown above. Additionally, the Vendor should identify the bid type as either a technical or cost proposal on the face of each bid envelope submitted in response to a request for proposal as follows:

BID TYPE:     Technical  
                   Cost

7. **BID OPENING:** Bids submitted in response to this Solicitation will be opened at the location identified below on the date and time listed below. Delivery of a bid after the bid opening date and time will result in bid disqualification. For purposes of this Solicitation, a bid is considered delivered when time stamped by the official Purchasing Division time clock.

Bid Opening Date and Time:

August 8, 2013 at 1:30 pm

Bid Opening Location:

Department of Administration, Purchasing Division  
2019 Washington Street East  
P.O. Box 50130,  
Charleston, WV 25305-0130

8. **ADDENDUM ACKNOWLEDGEMENT:** Changes or revisions to this Solicitation will be made by an official written addendum issued by the Purchasing Division. Vendor should acknowledge receipt of all addenda issued with this Solicitation by completing an Addendum Acknowledgment Form, a copy of which is included herewith. Failure to acknowledge addenda may result in bid disqualification. The addendum acknowledgement should be submitted with the bid to expedite document processing.
9. **BID FORMATTING:** Vendor should type or electronically enter the information onto its bid to prevent errors in the evaluation. Failure to type or electronically enter the information may result in bid disqualification.



**ADDITIONAL TERMS AND CONDITIONS (Construction Contracts Only)**

1. **CONTRACTOR'S LICENSE:** West Virginia Code § 21-11-2 requires that all persons desiring to perform contracting work in this state be licensed. The West Virginia Contractors Licensing Board is empowered to issue the contractor's license. Applications for a contractor's license may be made by contacting the West Virginia Division of Labor.

West Virginia Code § 21-11-11 requires any prospective Vendor to include the contractor's license number on its bid. Failure to include a contractor's license number on the bid shall result in Vendor's bid being disqualified. Vendors should include a contractor's license number in the space provided below.

Contractor's Name:

Contractor's License No.

The apparent successful Vendor must furnish a copy of its contractor's license prior to the issuance of a purchase order/contract.

2. **DRUG-FREE WORKPLACE AFFIDAVIT:** W. Va. Code § 21-1D-5 provides that any solicitation for a public improvement contract requires each Vendor that submits a bid for the work to submit at the same time an affidavit that the Vendor has a written plan for a drug-free workplace policy. To comply with this law, Vendor must either complete the enclosed drug-free workplace affidavit and submit the same with its bid or complete a similar affidavit that fulfills all of the requirements of the applicable code. Failure to submit the signed and notarized drug-free workplace affidavit, or a similar affidavit that fully complies with the requirements of the applicable code, with the bid shall result in disqualification of Vendor's bid.
3. **DRUG FREE WORKPLACE REPORT:** Pursuant to W. Va. Code § 21-1D-7b, no less than once per year, or upon completion of the project, every contractor shall provide a certified report to the public authority which let the contract. For contracts over \$25,000, the public authority shall be the West Virginia Purchasing Division. For contracts of \$25,000 or less, the public authority shall be the agency issuing the contract. The report shall include:
  - (1) Information to show that the education and training service to the requirements of West Virginia Code § 21-1D-5 was provided;
  - (2) The name of the laboratory certified by the United States Department of Health and Human Services or its successor that performs the drug tests;
  - (3) The average number of employees in connection with the construction on the public improvement;

00000127

Agency GARLOW INS. AGENCY, INC.  
REQ.P.O# \_\_\_\_\_

**BID BOND**

KNOW ALL MEN BY THESE PRESENTS, That we, the undersigned, S & M TOTAL COMFORT, LLC  
of TORNADO, WEST VIRGINIA, as Principal, and OLD REPUBLIC SURETY GROUP  
of MILWAUKEE, WISCONSIN, a corporation organized and existing under the laws of the State of WISCONSIN  
with its principal office in the City of MILWAUKEE, as Surety, are held and firmly bound unto the State  
of West Virginia, as Obligee, in the penal sum of ONE THOUSAND SEVEN HUNDRED SIXTEEN (\$ 1,716.00) for the payment of which,  
well and truly to be made, we jointly and severally bind ourselves, our heirs, administrators, executors, successors and assigns.

The Condition of the above obligation is such that whereas the Principal has submitted to the Purchasing Section of the  
Department of Administration a certain bid or proposal, attached hereto and made a part hereof, to enter into a contract in writing for  
HEATING & COOLING INSTALLATION (HVAC)

NOW THEREFORE,

- (a) If said bid shall be rejected, or
- (b) If said bid shall be accepted and the Principal shall enter into a contract in accordance with the bid or proposal attached hereto and shall furnish any other bonds and insurance required by the bid or proposal, and shall in all other respects perform the agreement created by the acceptance of said bid, then this obligation shall be null and void, otherwise this obligation shall remain in full force and effect. It is expressly understood and agreed that the liability of the Surety for any and all claims hereunder shall, in no event, exceed the penal amount of this obligation as herein stated.

The Surety, for the value received, hereby stipulates and agrees that the obligations of said Surety and its bond shall be in no way impaired or affected by any extension of the time within which the Obligee may accept such bid, and said Surety does hereby waive notice of any such extension.

WITNESS, the following signatures and seals of Principal and Surety, executed and sealed by a proper officer of Principal and Surety, or by Principal individually if Principal is an individual, this 7<sup>th</sup> day of August, 2013.

Principal Seal



STACY L. BRANHAM  
(Name of Principal)  
By [Signature]  
(Must be President, Vice President, or Duly Authorized Agent)  
OWNER  
(Title)

Surety Seal

OLD REPUBLIC SURETY GROUP  
(Name of Surety)  
[Signature]  
Attorney-in-Fact

**IMPORTANT** – Surety executing bonds must be licensed in West Virginia to transact surety insurance, must affix its seal, and must attach a power of attorney with its seal affixed.



POWER OF ATTORNEY

KNOW ALL MEN BY THESE PRESENTS: That OLD REPUBLIC SURETY COMPANY, a Wisconsin stock insurance corporation, does make, constitute and appoint:

PHILIP P. GARLOW, TONY E. LUCAS, TINA LYNN WHITE, LINDA E. GOFF, DERREL MATTHEW BEARD, OF CHARLESTON, WV

its true and lawful Attorney(s)-in-Fact, with full power and authority, not exceeding \$10,000,000, for and on behalf of the company as surety, to execute and deliver and affix the seal of the company thereto (if a seal is required), bonds, undertakings, recognizances or other written obligations in the nature thereof, (other than bail bonds, bank depository bonds, mortgage deficiency bonds, mortgage guaranty bonds, guarantees of installment paper and note guaranty bonds, self-insurance workers compensation bonds guaranteeing payment of benefits, asbestos abatement contract bonds, waste management bonds, hazardous waste remediation bonds or black lung bonds), as follows:

ALL WRITTEN INSTRUMENTS IN AN AMOUNT NOT TO EXCEED AN AGGREGATE OF TWO HUNDRED FIFTY THOUSAND DOLLARS (\$250,000) ----- FOR ANY SINGLE OBLIGATION, REGARDLESS OF THE NUMBER OF INSTRUMENTS ISSUED FOR THE OBLIGATION.

and to bind OLD REPUBLIC SURETY COMPANY thereby, and all of the acts of said Attorneys-in-Fact, pursuant to these presents, are ratified and confirmed. This document is not valid unless printed on colored background and is multi-colored. This appointment is made under and by authority of the board of directors at a special meeting held on February 18, 1982. This Power of Attorney is signed and sealed by facsimile under and by the authority of the following resolutions adopted by the board of directors of the OLD REPUBLIC SURETY COMPANY on February 18, 1982.

RESOLVED that, the president, any vice-president, or assistant vice president in conjunction with the secretary or any assistant secretary, may appoint attorneys-in-fact or agents with authority as defined or limited in the instrument evidencing the appointment in each case, for and on behalf of the company to execute and deliver and affix the seal of the company to bonds, undertakings, recognizances, and suretyship obligations of all kinds; and said officers may remove any such attorney-in-fact or agent and revoke any Power of Attorney previously granted to such person.

- RESOLVED FURTHER, that any bond, undertaking, recognizance, or suretyship obligation shall be valid and binding upon the Company (i) when signed by the president, any vice president or assistant vice president, and attested and sealed (if a seal be required) by any secretary or assistant secretary; or (ii) when signed by the president, any vice president or assistant vice president, secretary or assistant secretary, and countersigned and sealed (if a seal be required) by a duly authorized attorney-in-fact or agent; or (iii) when duly executed and sealed (if a seal be required) by one or more attorneys-in-fact or agents pursuant to and within the limits of the authority evidenced by the Power of Attorney issued by the company to such person or persons.

RESOLVED FURTHER, that the signature of any authorized officer and the seal of the company may be affixed by facsimile to any Power of Attorney or certification thereof authorizing the execution and delivery of any bond, undertaking, recognizance, or other suretyship obligations of the company; and such signature and seal when so used shall have the same force and effect as though manually affixed.

IN WITNESS WHEREOF, OLD REPUBLIC SURETY COMPANY has caused these presents to be signed by its proper officer, and its corporate seal to be affixed this 6TH day of AUGUST, 2008.

[Signature of Assistant Secretary]

Assistant Secretary



OLD REPUBLIC SURETY COMPANY

[Signature of Gerald C. Leach]

President

STATE OF WISCONSIN, COUNTY OF WAUKESHA - SS

On this 6TH day of AUGUST, 2008, personally came before me, GERALD C. LEACH and RICK A. JOHNSON to me known to be the individuals and officers of the OLD REPUBLIC SURETY COMPANY who executed the above instrument, and they each acknowledged the execution of the same, and being by me duly sworn, did severally depose and say; that they are said officers of the corporation aforesaid, and that the seal affixed to the above instrument is the seal of the corporation, and that said corporate seal and their signatures as such officers were duly affixed and subscribed to the said instrument by the authority of the board of directors of said corporation.



[Signature of Sharon A. Piezo]

Notary Public

My commission expires: 01/18/2009

CERTIFICATE

I, the undersigned, assistant secretary of the OLD REPUBLIC SURETY COMPANY, a Wisconsin corporation, CERTIFY that the foregoing and attached Power of Attorney remains in full force and has not been revoked; and furthermore, that the Resolutions of the board of directors set forth in the Power of Attorney, are now in force.

27-1202



Signed and sealed at the City of Brookfield, WI this \_\_\_ day of \_\_\_

GARLOW INSURANCE AGENCY INC.

[Signature of Jane E. Cheney]

Assistant Secretary

REQUEST FOR QUOTATION  
EBA464 HVAC System for Television Studio

**PRICING PAGE**

Shipping costs shall be included in equipment price.

Description	QTY	Unit Price	Extended Price
Trane Voyager HVAC system or equal with a minimum cooling rating of 25 ton BTU. To include all materials, equipment and incidentals.	1	<u>\$24,000</u>	<u>\$31,200</u>
Labor to install a Trane Voyager HVAC System or equal per the spec. provided.	1	<u>\$2,400</u>	<u>\$3,120</u>

**GRAND TOTAL** \$ 34,320

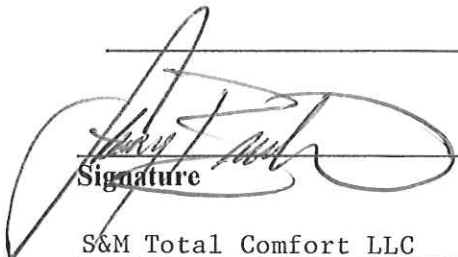
  
\_\_\_\_\_  
Signature

8/8/2013  
Date

S&M Total Comfort LLC  
Company Name

304-356-7407  
Phone

304-722-5899  
FAX

smtotalcomfort@gmail.com  
E-mail

**CERTIFICATION AND SIGNATURE PAGE**

By signing below, I certify that I have reviewed this Solicitation in its entirety; understand the requirements, terms and conditions, and other information contained herein; that I am submitting this bid or proposal for review and consideration; that I am authorized by the bidder to execute this bid or any documents related thereto on bidder's behalf; that I am authorized to bind the bidder in a contractual relationship; and that to the best of my knowledge, the bidder has properly registered with any State agency that may require registration.

S&M Total Comfort LLC  
(Company)

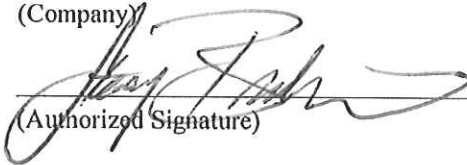
  
(Authorized Signature)

Stacy Branham, Owner  
(Representative Name, Title)

304-356-7407                      304-722-5899  
(Phone Number)                      (Fax Number)

8/8/2013  
(Date)

**ADDENDUM ACKNOWLEDGEMENT FORM**

**SOLICITATION NO.:** EBA464

**Instructions:** Please acknowledge receipt of all addenda issued with this solicitation by completing this addendum acknowledgment form. Check the box next to each addendum received and sign below. Failure to acknowledge addenda may result in bid disqualification.

**Acknowledgment:** I hereby acknowledge receipt of the following addenda and have made the necessary revisions to my proposal, plans and/or specification, etc.

**Addendum Numbers Received:**

(Check the box next to each addendum received)

- |  |  |
|--|--|
| <input checked="" type="checkbox"/> ] Addendum No. 1 | <input type="checkbox"/> ] Addendum No. 6  |
| <input checked="" type="checkbox"/> ] Addendum No. 2 | <input type="checkbox"/> ] Addendum No. 7  |
| <input type="checkbox"/> ] Addendum No. 3            | <input type="checkbox"/> ] Addendum No. 8  |
| <input type="checkbox"/> ] Addendum No. 4            | <input type="checkbox"/> ] Addendum No. 9  |
| <input type="checkbox"/> ] Addendum No. 5            | <input type="checkbox"/> ] Addendum No. 10 |

I understand that failure to confirm the receipt of addenda may be cause for rejection of this bid. I further understand that any verbal representation made or assumed to be made during any oral discussion held between Vendor's representatives and any state personnel is not binding. Only the information issued in writing and added to the specifications by an official addendum is binding.

S&M Total Comfort LLC

Company

Authorized Signature

8/8/2013

Date

NOTE: This addendum acknowledgment should be submitted with the bid to expedite document processing.



State of West Virginia  
 Department of Administration  
 Purchasing Division  
 2019 Washington Street East  
 Post Office Box 50130  
 Charleston, WV 25305-0130

**Solicitation**

NUMBER
EBA464

PAGE
1

ADDRESS CORRESPONDENCE TO ATTENTION OF:
CONNIE OSWALD 304-558-2157

RFQ COPY  
 TYPE NAME/ADDRESS HERE

VENDOR

SHIP TO

WSWP-TV  
 AIRPORT ROAD  
 BECKLEY, WV  
 25801 255-1501

DATE PRINTED
07/25/2013

BID OPENING DATE: 08/08/2013 BID OPENING TIME 1:30PM

LINE	QUANTITY	UOP	CAT. NO.	ITEM NUMBER	UNIT PRICE	AMOUNT
				ADDENDUM NO. 1		
1.				TO CLARIFY AND CONFIRM THE MANDATORY PRE-BID MEETING SCHEDULED FOR JULY 30, 2013 AT 10:30 AM, PREVIOUSLY LISTED IN THE PURCHASING BULLETIN IN ERROR. LOCATION HAS NOT CHANGED.		
2.				TO PROVIDE THE ADDENDUM ACKNOWLEDGMENT. THIS DOCUMENT SHOULD BE SIGNED AND RETURNED WITH YOUR BID. FAILURE TO SIGN AND RETURN MAY RESULT IN DISQUALIFICATION OF YOUR BID.		
				END OF ADDENDUM NO. 1		

SIGNATURE	TELEPHONE 304-356-7407	DATE 8/8/2013
TITLE Owner	FEN 46-2563811	ADDRESS CHANGES TO BE NOTED ABOVE

WHEN RESPONDING TO SOLICITATION, INSERT NAME AND ADDRESS IN SPACE ABOVE LABELED 'VENDOR'





State of West Virginia  
 Department of Administration  
 Purchasing Division  
 2019 Washington Street East  
 Post Office Box 50130  
 Charleston, WV 25305-0130

**Solicitation**

NUMBER
EBA464

PAGE
1

ADDRESS CORRESPONDENCE TO ATTENTION OF:
CONNIE OSWALD 304-558-2157

RFQ COPY  
 TYPE NAME/ADDRESS HERE

VENDOR

SHIP TO

WSWP-TV  
 AIRPORT ROAD  
 BECKLEY, WV  
 25801 255-1501

DATE PRINTED
08/02/2013

BID OPENING DATE: 08/08/2013 BID OPENING TIME 1:30PM

LINE	QUANTITY	UOP	CAT. NO.	ITEM NUMBER	UNIT PRICE	AMOUNT
				ADDENDUM NO. 2		
				1. TO PROVIDE ANSWERS TO QUESTIONS RECEIVED FOR THIS SOLICITATION.		
				2. TO PROVIDE THE MANDATORY PRE-BID SIGN IN SHEETS.		
				3. TO PROVIDE THE ADDENDUM ACKNOWLEDGMENT. THIS DOCUMENT SHOULD BE SIGNED AND RETURNED WITH BID, FAILURE TO SIGN AND RETURN MAY RESULT IN DISQUALIFICATION OF YOUR BID.		
				END OF ADDENDUM NO. 2		

SIGNATURE	TELEPHONE 304-356-7407	DATE 8/8/2013
TITLE Owner	FEIN 46-2563811	ADDRESS CHANGES TO BE NOTED ABOVE

WHEN RESPONDING TO SOLICITATION, INSERT NAME AND ADDRESS IN SPACE ABOVE LABELED 'VENDOR'





**State of West Virginia  
DRUG FREE WORKPLACE CONFORMANCE AFFIDAVIT  
West Virginia Code §21-1D-5**

STATE OF West Virginia

COUNTY OF Kanawha, TO-WIT:

I, Stacy Branham, after being first duly sworn, depose and state as follows:

1. I am an employee of S&M Total Comfort LLC; and,  
(Company Name)
2. I do hereby attest that S&M Total Comfort LLC  
(Company Name)

maintains a valid written drug free workplace policy and that such policy is in compliance with **West Virginia Code §21-1D-5**.

The above statements are sworn to under the penalty of perjury.

S&M Total Comfort LLC  
(Company Name)

By: Stacy Branham

Title: Owner

Date: 8/8/2013

Taken, subscribed and sworn to before me this 8 day of August.

By Commission expires July 6, 2020



NOTARY PUBLIC - OFFICIAL SEAL  
KENDRA A. MARKER  
State of West Virginia  
My Comm. Expires Jul 6, 2020  
RCAC, Inc. 1116 Smith St., Suite 202  
Charleston, WV 25301

Kendra A. Marker  
(Notary Public)

**THIS AFFIDAVIT MUST BE SUBMITTED WITH THE BID IN ORDER TO COMPLY WITH WV CODE PROVISIONS. FAILURE TO INCLUDE THE AFFIDAVIT WITH THE BID SHALL RESULT IN DISQUALIFICATION OF THE BID.**

STATE OF WEST VIRGINIA  
Purchasing Division

**PURCHASING AFFIDAVIT**

**MANDATE:** Under W. Va. Code §5A-3-10a, no contract or renewal of any contract may be awarded by the state or any of its political subdivisions to any vendor or prospective vendor when the vendor or prospective vendor or a related party to the vendor or prospective vendor is a debtor and: (1) the debt owed is an amount greater than one thousand dollars in the aggregate; or (2) the debtor is in employer default.

**EXCEPTION:** The prohibition listed above does not apply where a vendor has contested any tax administered pursuant to chapter eleven of the W. Va. Code, workers' compensation premium, permit fee or environmental fee or assessment and the matter has not become final or where the vendor has entered into a payment plan or agreement and the vendor is not in default of any of the provisions of such plan or agreement.

**DEFINITIONS:**

**"Debt"** means any assessment, premium, penalty, fine, tax or other amount of money owed to the state or any of its political subdivisions because of a judgment, fine, permit violation, license assessment, defaulted workers' compensation premium, penalty or other assessment presently delinquent or due and required to be paid to the state or any of its political subdivisions, including any interest or additional penalties accrued thereon.

**"Employer default"** means having an outstanding balance or liability to the old fund or to the uninsured employers' fund or being in policy default, as defined in W. Va. Code § 23-2c-2, failure to maintain mandatory workers' compensation coverage, or failure to fully meet its obligations as a workers' compensation self-insured employer. An employer is not in employer default if it has entered into a repayment agreement with the Insurance Commissioner and remains in compliance with the obligations under the repayment agreement.

**"Related party"** means a party, whether an individual, corporation, partnership, association, limited liability company or any other form or business association or other entity whatsoever, related to any vendor by blood, marriage, ownership or contract through which the party has a relationship of ownership or other interest with the vendor so that the party will actually or by effect receive or control a portion of the benefit, profit or other consideration from performance of a vendor contract with the party receiving an amount that meets or exceeds five percent of the total contract amount.

**AFFIRMATION:** By signing this form, the vendor's authorized signer affirms and acknowledges under penalty of law for false swearing (W. Va. Code §61-5-3) that neither vendor nor any related party owe a debt as defined above and that neither vendor nor any related party are in employer default as defined above, unless the debt or employer default is permitted under the exception above.

**WITNESS THE FOLLOWING SIGNATURE:**

Vendor's Name: S&M Total Comfort LLC

Authorized Signature: [Signature] Date: 8/8/2013

State of WV

County of Kanawha, to-wit:

Taken, subscribed, and sworn to before me this 8 day of August, 2013.

My Commission expires July 6, 2020, 2020.

AFFIX SEAL HERE

NOTARY PUBLIC Kendra A. Marker

*Purchasing Affidavit (Revised 07/01/2012)*





# CERTIFICATE OF LIABILITY INSURANCE

DATE (MM/DD/YYYY)  
06/18/2013

THIS CERTIFICATE IS ISSUED AS A MATTER OF INFORMATION ONLY AND CONFERS NO RIGHTS UPON THE CERTIFICATE HOLDER. THIS CERTIFICATE DOES NOT AFFIRMATIVELY OR NEGATIVELY AMEND, EXTEND OR ALTER THE COVERAGE AFFORDED BY THE POLICIES BELOW. THIS CERTIFICATE OF INSURANCE DOES NOT CONSTITUTE A CONTRACT BETWEEN THE ISSUING INSURER(S), AUTHORIZED REPRESENTATIVE OR PRODUCER, AND THE CERTIFICATE HOLDER.

**IMPORTANT:** If the certificate holder is an ADDITIONAL INSURED, the policy(ies) must be endorsed. If SUBROGATION IS WAIVED, subject to the terms and conditions of the policy, certain policies may require an endorsement. A statement on this certificate does not confer rights to the certificate holder in lieu of such endorsement(s).

<b>PRODUCER</b> Garlow Insurance Agency, Inc. 1217 Quarrier Street  Charleston, WV 25301	<b>CONTACT NAME:</b> PHONE (A/C, No, Ext): (304)347-8972 E-MAIL ADDRESS:	FAX (A/C, No): (304)347-8973													
	<table border="1"> <thead> <tr> <th>INSURER(S) AFFORDING COVERAGE</th> <th>NAIC #</th> </tr> </thead> <tbody> <tr> <td>INSURER A : Erie Insurance</td> <td></td> </tr> <tr> <td>INSURER B :</td> <td></td> </tr> <tr> <td>INSURER C :</td> <td></td> </tr> <tr> <td>INSURER D :</td> <td></td> </tr> <tr> <td>INSURER E :</td> <td></td> </tr> <tr> <td>INSURER F :</td> <td></td> </tr> </tbody> </table>		INSURER(S) AFFORDING COVERAGE	NAIC #	INSURER A : Erie Insurance		INSURER B :		INSURER C :		INSURER D :		INSURER E :		INSURER F :
INSURER(S) AFFORDING COVERAGE	NAIC #														
INSURER A : Erie Insurance															
INSURER B :															
INSURER C :															
INSURER D :															
INSURER E :															
INSURER F :															

**COVERAGES**                      **CERTIFICATE NUMBER:**                      **REVISION NUMBER:**

THIS IS TO CERTIFY THAT THE POLICIES OF INSURANCE LISTED BELOW HAVE BEEN ISSUED TO THE INSURED NAMED ABOVE FOR THE POLICY PERIOD INDICATED. NOTWITHSTANDING ANY REQUIREMENT, TERM OR CONDITION OF ANY CONTRACT OR OTHER DOCUMENT WITH RESPECT TO WHICH THIS CERTIFICATE MAY BE ISSUED OR MAY PERTAIN, THE INSURANCE AFFORDED BY THE POLICIES DESCRIBED HEREIN IS SUBJECT TO ALL THE TERMS, EXCLUSIONS AND CONDITIONS OF SUCH POLICIES. LIMITS SHOWN MAY HAVE BEEN REDUCED BY PAID CLAIMS.

INSR LTR	TYPE OF INSURANCE	ADDL SUBR INSR WVD	POLICY NUMBER	POLICY EFF (MM/DD/YYYY)	POLICY EXP (MM/DD/YYYY)	LIMITS
A	<b>GENERAL LIABILITY</b> <input type="checkbox"/> COMMERCIAL GENERAL LIABILITY <input type="checkbox"/> CLAIMS-MADE <input checked="" type="checkbox"/> OCCUR  GEN'L AGGREGATE LIMIT APPLIES PER: <input checked="" type="checkbox"/> POLICY <input type="checkbox"/> PRO-JECT <input type="checkbox"/> LOC		Q306820115	6/18/2013	6/18/2014	EACH OCCURRENCE \$ 1,000,000 DAMAGE TO RENTED PREMISES (Ea occurrence) \$ 1,000,000 MED EXP (Any one person) \$ 5,000 PERSONAL & ADV INJURY \$ 1,000,000 GENERAL AGGREGATE \$ 2,000,000 PRODUCTS - COMP/OP AGG \$ 2,000,000
	<b>AUTOMOBILE LIABILITY</b> <input type="checkbox"/> ANY AUTO <input type="checkbox"/> ALL OWNED AUTOS <input type="checkbox"/> SCHEDULED AUTOS <input type="checkbox"/> HIRED AUTOS <input type="checkbox"/> NON-OWNED AUTOS					COMBINED SINGLE LIMIT (Ea accident) \$ BODILY INJURY (Per person) \$ BODILY INJURY (Per accident) \$ PROPERTY DAMAGE (Per accident) \$
	<b>UMBRELLA LIAB</b> <input type="checkbox"/> OCCUR <b>EXCESS LIAB</b> <input type="checkbox"/> CLAIMS-MADE DED RETENTION \$					EACH OCCURRENCE \$ AGGREGATE \$
	<b>WORKERS COMPENSATION AND EMPLOYERS' LIABILITY</b> ANY PROPRIETOR/PARTNER/EXECUTIVE OFFICER/MEMBER EXCLUDED? (Mandatory in NH) If yes, describe under DESCRIPTION OF OPERATIONS below	Y/N	N/A			WC STATUTORY LIMITS OTHER E.L. EACH ACCIDENT \$ E.L. DISEASE - EA EMPLOYEE \$ E.L. DISEASE - POLICY LIMIT \$

DESCRIPTION OF OPERATIONS / LOCATIONS / VEHICLES (Attach ACORD 101, Additional Remarks Schedule, If more space is required)  
Contractors Enhancement Endorsement

<b>CERTIFICATE HOLDER</b> Proof of coverage	<b>CANCELLATION</b> SHOULD ANY OF THE ABOVE DESCRIBED POLICIES BE CANCELLED BEFORE THE EXPIRATION DATE THEREOF, NOTICE WILL BE DELIVERED IN ACCORDANCE WITH THE POLICY PROVISIONS.
	AUTHORIZED REPRESENTATIVE 

# BOGGS

# "PROPOSAL"

## ROOFING, INC.

Contractor License No. WV003858

P.O. BOX 7455 320 WEST 15<sup>TH</sup> STREET HUNTINGTON, WV 25776-7455 304-429-4233 FAX: 304-429-2811

To: S&M Total Comfort

Fax: (304) 722-5899

Page	<u>1</u>	of	<u>1</u>
Date	<u>8/6/2013</u>		
Project	<u>WVPBS</u>		
	<u>New Curb Flashing</u>		
Location	<u>Beckley, WV</u>		

We propose to furnish the necessary material and labor to complete the work as outlined below:

1. Cut existing roof membrane to allow for installation of new roof curb.
2. Flash one (1) approximately 7'x10' roof curb into the roof system.
3. Flash up to two (2) 1" conduits into the roof system.

Notes:

1. All flashing work to be done in one day with one mobilization.
2. Installation of roof curb and blocking is excluded.
3. Excludes all bonds and permits.
4. Any temporary drying in of the top of the roof curb is excluded.
5. Any penetrations not listed above are excluded.

The above proposal for the sum of

Five Thousand Four Hundred Thirty Dollars

\$

5,430.00

*Proposal for acceptance within 30 days.*

Accepted: (Sign & return one (1) copy)

Firm \_\_\_\_\_  
 By \_\_\_\_\_  
 Title \_\_\_\_\_  
 Date \_\_\_\_\_

**BOGGS ROOFING, INC.**

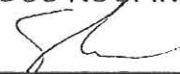
  
 \_\_\_\_\_  
 Shane Abshire

Protected by West Virginia Workman's Compensation  
Public Liability and Property Damage Insurance

# R.E. MICHEL COMPANY, INC.

Wholesale Distributors

SPECIAL PRICING QUOTATION



**QUOTE TO**

**JOB NAME** TV Job

Account Nbr 857305

Account Name S & M Total Comfort, LLC

Address Rt. 4 Boc 163 A

Charleston ,Wv. 25312

Contact Name \_\_\_\_\_

Phone 304-984-3778

Fax \_\_\_\_\_

E-Mail \_\_\_\_\_

Quote Date Aug. 1,2013

Quote Expires Sept. 1,2013

Quoted By Alan O'Bryan

1	BAYCURB027B	KNOCKED DOWN		\$243.00
	14" TALL FLAT CONVENTIONAL ROOF CURB			
1	AYDHTRL354A	FIELD INSTALLED		\$697.00
	54 KW @ 230-3PH ELECTRIC HEATER			
	UNIT AND HEATER ARE SINGLE POINT POWER ENTRY			
1	BAYECONO90B	FIELD INSTALLED		\$889.00
	0-100% ECONOMIZER DRY BULB CONTROLS			
1	TSD300F3R0A0000			\$11,721.00
	25 TON PKG. A/C R410A / 208-230-3PH			
	272,000 COOLING NO HEAT			
	RELIA TEL CONTROLS LOW AMB. TO ZERO DEG.			
	DOWNFLOW ONLY			

**\$13,550.00**

TAX

**\$813.00**

FREIGHT CHARGE

TOTAL QUOTED AMOUNT

**\$14,363.00**

Quote Notes CURRENTLY NEED 5-7 WORKING DAY LEADTIME

Customer : Stacy / HVAC Solutions

Project : TV

Name : TV

**T4V**

**General**

Unit function	<b>DX cooling</b>	Unit controls	<b>Reliatel</b>
---------------	-------------------	---------------	-----------------

**Main Cooling**

Cooling Entering Dry Bulb	<b>80.00</b>	Cooling Entering Wet Bulb	<b>67.00</b>
Ambient Temp	<b>95.00</b>	Saturated Suction Temp Circuit 1	<b>0.00</b>
Airflow	<b>Downflow</b>	Tonnage	<b>25 Ton</b>

**Motor/Electrical**

Voltage	<b>208-230/60/3</b>
---------	---------------------

**Field installed accessories**

Fresh air selection	<b>0-100% Economizer, dry bulb control</b>	Electric heaters	<b>54 kW electric heater</b>
Roof curb	<b>Roof curb</b>		

**Notes**

Enter Notes

## Job Information

*American Standard*  
NEW STANDARDS FOR LIVING™

Tag	T4V	Model number	TSD300F3R0A**0000000000
Quantity	1		000000000000000000

## Unit Information

Tonnage	25 Ton	Unit function	DX cooling
Min. Unit Operating Weight		Max Unit Operating Weight	
Design Airflow			

## Cooling Information

Gross Total Capacity		Gross Sensible Capacity	
Gross Latent Capacity		Net Total Capacity	
Net Sensible Capacity		Net Sensible Heat Ratio	
Cooling Entering Dry Bulb	80.00 F	Cooling Entering Wet Bulb	67.00 F
Cooling Leaving Unit DB		Cooling Leaving Unit WB	
Ambient Temp	95.00 F		

## Heating Information

Heating capacity	Without heat	Heating EAT
Output Htg Capacity		Heating LAT
Heating Temp Rise		

## Motor/Electrical Information

Voltage	208-230/60/3	Design ESP
Indoor Motor Power		Indoor Mtr. Operating Power
Compressor Power		System Power
MCA		MOP
Condenser Fan FLA		Evaporator Fan FLA
Compressor 1 RLA		Compressor 2 RLA

## Information for LEED Projects

ASHRAE 90.1	
Refrig charge (HFC-410A) - ckt 1	Compressor Power
Refrig charge (HFC-410A) - ckt 2	Outdoor Motor Power

Job Information

*American Standard*  
NEW STANDARDS FOR LIVING™

---

Tag	T4V	Model number	TSD300F3R0A**0000000000
Quantity	1		000000000000000000

---

Rated capacity (AHRI)	Indoor Mtr. Operating Power
SEER @ AHRI	Exhaust fan power

Electrical values provided are estimated only and are subject to change without notice and may differ from nameplate values.



- NOTES:  
 1 THRU THE BASE GAS AND ELECTRICAL IS NOT STANDARD ON ALL UNITS. (SELECTED OPTION; SEE ACCESSORY SHEET)  
 2 VERIFY WEIGHT, CONNECTION, AND ALL DIMENSION WITH INSTALLER DOCUMENTS BEFORE INSTALLATION

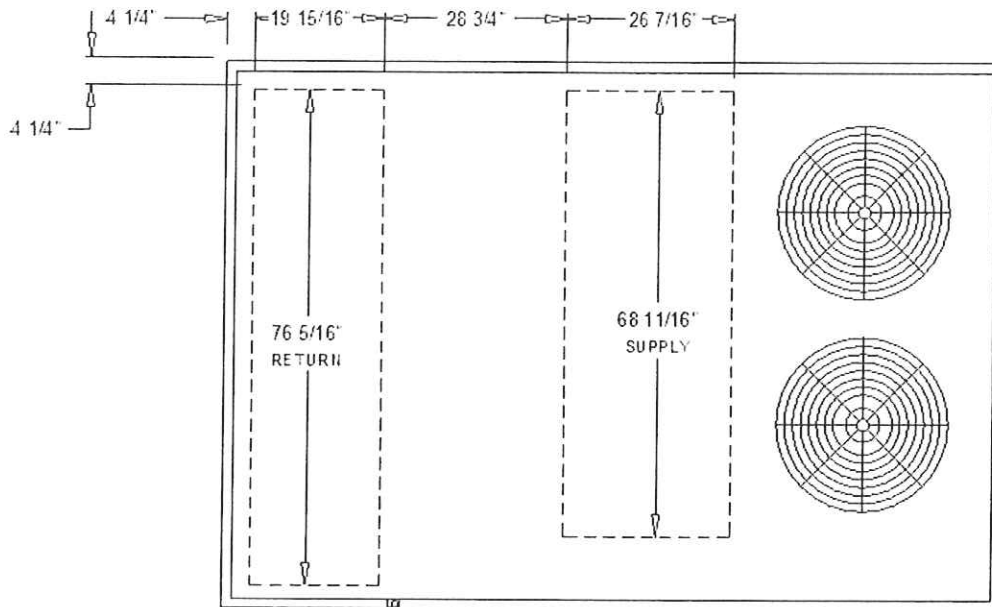
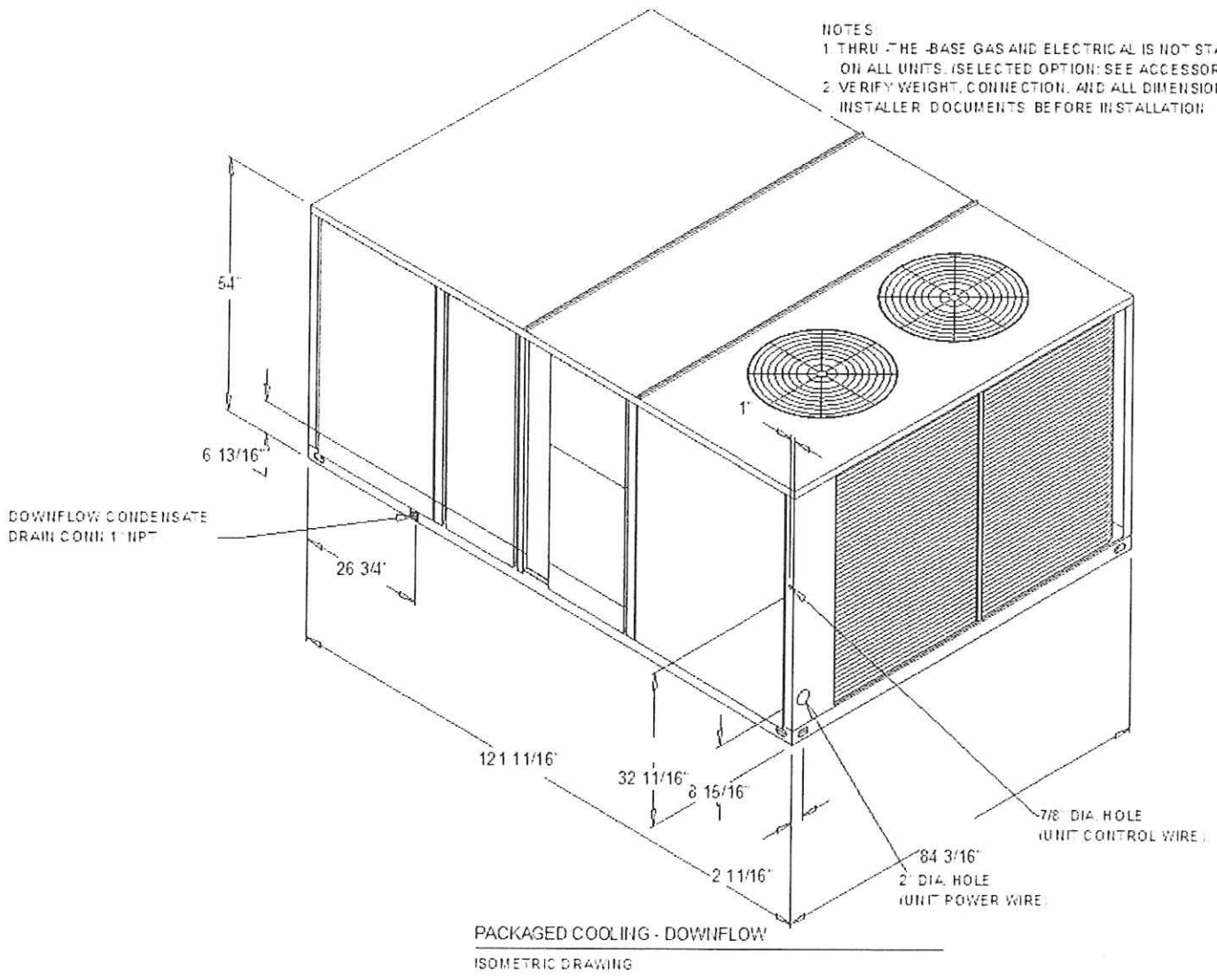

## ELECTRICAL / GENERAL DATA

<b>GENERAL</b> Model (Tons): TSD300F (25.0) Unit Operating Voltage Range: 187-252 Unit Primary Voltage: 208 Unit Secondary Voltage: 230 Unit Hertz: 60 Unit Phase: 3		<b>Standard Motor</b> Minimum Circuit Ampacity: 124.0 Maximum Fuse Size: 150.0 Maximum (HACR) Circuit Breaker: 150.0	
EER: 10.0		<b>Oversized Motor</b> Minimum Circuit Ampacity: Maximum Fuse Size: Maximum (HACR) Circuit Breaker:	
		<b>Field Installed Oversized Motor</b> Minimum Circuit Ampacity: Maximum Fuse Size: Maximum (HACR) Circuit Breaker:	
<b>HEATER</b> Heater kW Rating: 5.4kW			
Standard Motor with Heat Stage: 2 Minimum Circuit Ampacity: 171.0/192.0 Maximum Fuse Size: 175.0/200.0 Maximum (HACR) Circuit Breaker: 175.0/200.0		<b>Oversized Motor</b> Minimum Circuit Ampacity: Maximum Fuse Size: Maximum (HACR) Circuit Breaker:	
		<b>Field Installed Oversized Motor</b> Minimum Circuit Ampacity: Maximum Fuse Size: Maximum (HACR) Circuit Breaker:	
<b>COMPRESSOR</b> Circuit #1 / 2 Number: 2 Horsepower: 10.0 Phase: 3 Rated Load Amps: 39.1 Locked Rotor Amps: 267		<b>OUTDOOR MOTOR</b> Number: 2 Horsepower: 1.00 Motor speed (RPM): 1,125 Phase: 1 Full Load Amps: 5.0 Locked Rotor Amps: 14.4	
<b>INDOOR MOTOR</b>			
<b>Standard Motor</b> Number: 1 Horsepower: 7.5 Motor Speed (RPM): 3,470 Phase: 3 Full Load Amps: 24.2 Locked Rotor Amps: 120.4		<b>Oversized Motor</b> Number: Horsepower: Motor Speed (RPM): Phase: Full Load Amps: Locked Rotor Amps:	
		<b>Field Installed Oversized Motor</b> Number: Horsepower: Motor Speed (RPM): Phase: Full Load Amps: Locked Rotor Amps:	
<b>POWER EXHAUST ACCESSORY</b> (Field Installed Power Exhaust) Horsepower: Motor Speed (RPM): Phase: Full Load Amps: Locked Rotor Amps:		<b>FILTERS</b> Type:                      Throwaway Furnished:              Yes Number:                  4 / 4 Recommended Size:    20"x20"x2" / 20"x25"x2"	
		<b>REFRIGERANT</b> Circuit #1 / 2 Type:                      R410 Factory Charge: Circuit #1 / 2:              10.5 lb/10.5 lb	

### NOTES

1. Maximum (HACR) Circuit Breaker sizing is for installations in the United States only.
2. Refrigerant charge is an approximate value. For a more precise value, see unit nameplate and service instructions.
3. Value does not include Power Exhaust Accessory.
4. Value includes oversized motor.
5. Value does not include Power Exhaust Accessory.
6. EER is rated at AHRI conditions and in accordance with DOE test procedures.

### INSTALLED ACCESSORIES NET WEIGHT DATA

ACCESSORY		WEIGHTS			
ECONOMIZER		80.0 lb			
MOTORIZED OUTSIDE AIR DAMPER					
MANUAL OUTSIDE AIR DAMPER					
HEATER		40.0 lb			
OVERSIZED MOTOR					
HIGH STATIC DRIVE					
HIGH EFFICIENCY MOTOR (FIOPS)					
THROUGH THE BASE ELECTRICAL (FIOPS)					
UNIT MOUNTED CIRCUIT BREAKER (FIOPS)					
UNIT MOUNTED DISCONNECT (FIOPS)					
POWERED CONVENIENCE OUTLET (FIOPS)					
HINGED DOORS (FIOPS)					
TOOL-LESS HAIL GUARD (FIOPS)					
POWER EXHAUST					
ROOF CURB		225.0 lb			
BASE UNIT WEIGHTS		CORNER WEIGHTS		CENTER OF GRAVITY	
SHIPPING	NET	(A)	(C)	(E) LENGTH	(F) WIDTH
2337.0 lb	1878.0 lb	(B) 595.0 lb	(D) 372.0 lb	60'	35'

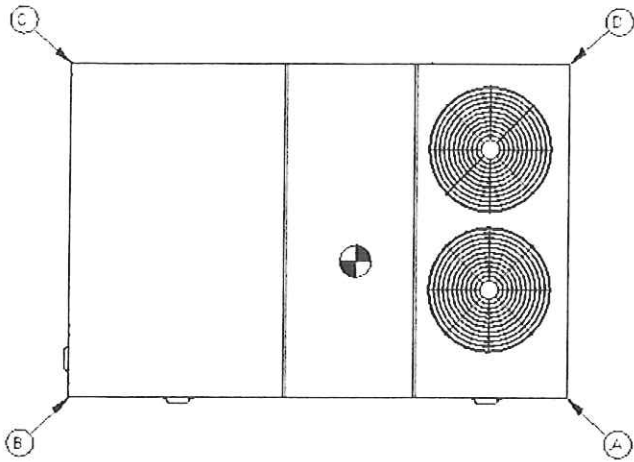

CORNER WEIGHT

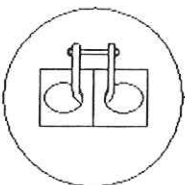
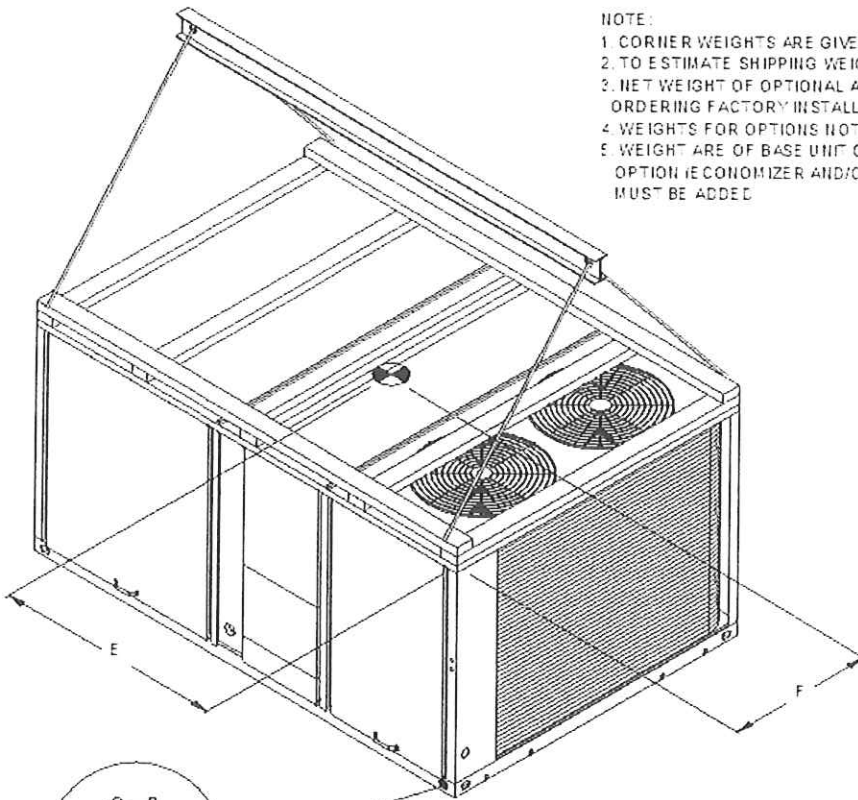

RIGGING AND CENTER OF GRAVITY

**NOTE:**

1. CORNER WEIGHTS ARE GIVEN FOR INFORMATION ONLY.
2. TO ESTIMATE SHIPPING WEIGHT OF OPTION/ACCESSORIES ADD 5 LBS TO NET WEIGHT.
3. NET WEIGHT OF OPTIONAL ACCESSORIES SHOULD BE ADD TO UNIT WEIGHT WHEN ORDERING FACTORY INSTALLED ACCESSORIES.
4. WEIGHTS FOR OPTIONS NOT LISTED ARE + 5 LBS.
5. WEIGHT ARE OF BASE UNIT ONLY. FOR TOTAL WEIGHT, 10 DIGIT FACTORY INSTALLED OPTION IE ECONOMIZER AND/OR OVERSIZED MOTOR OR FIOP/ACCESSORY WEIGHT MUST BE ADDED.

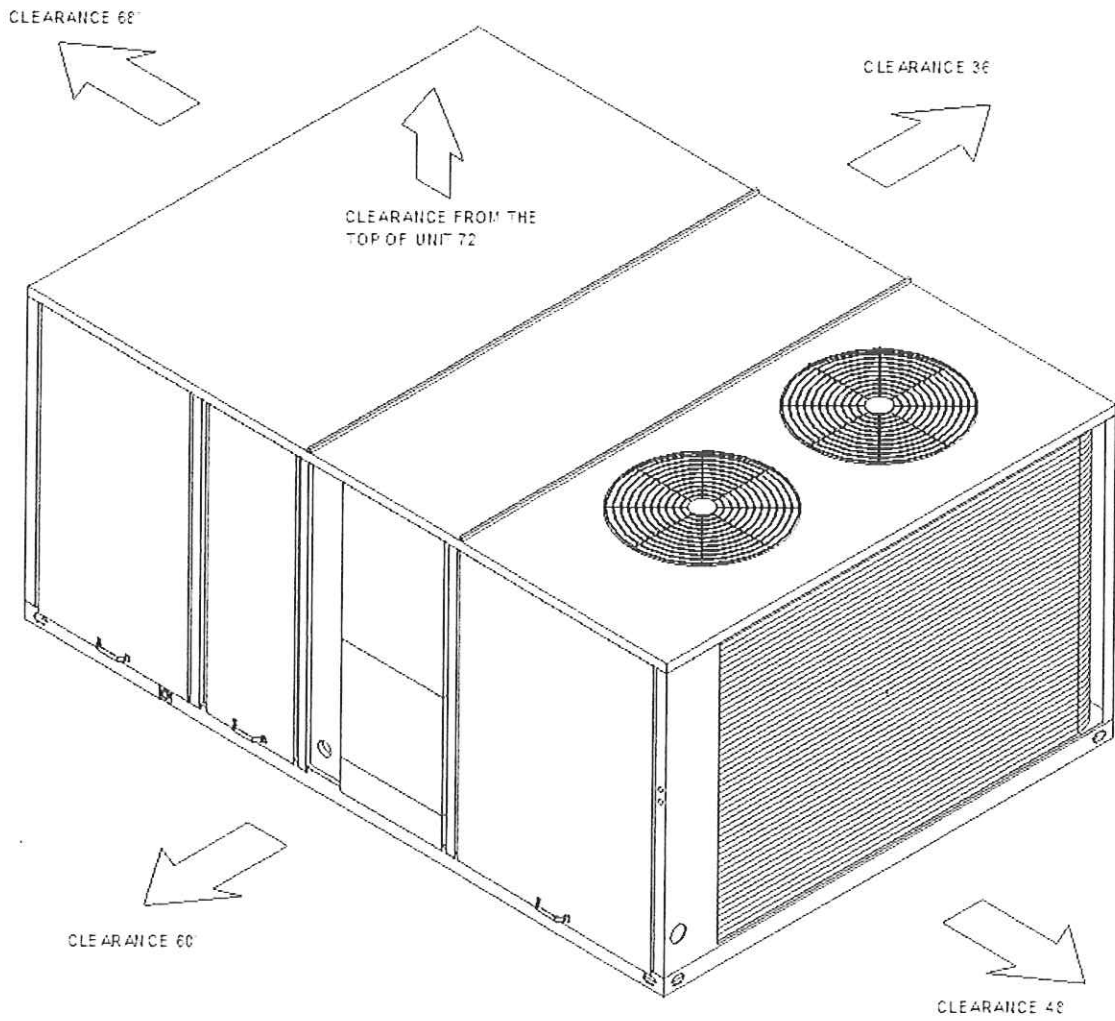

DOWNFLOW-PACKAGED COOLING WITH ELECTRIC CLEARANCE

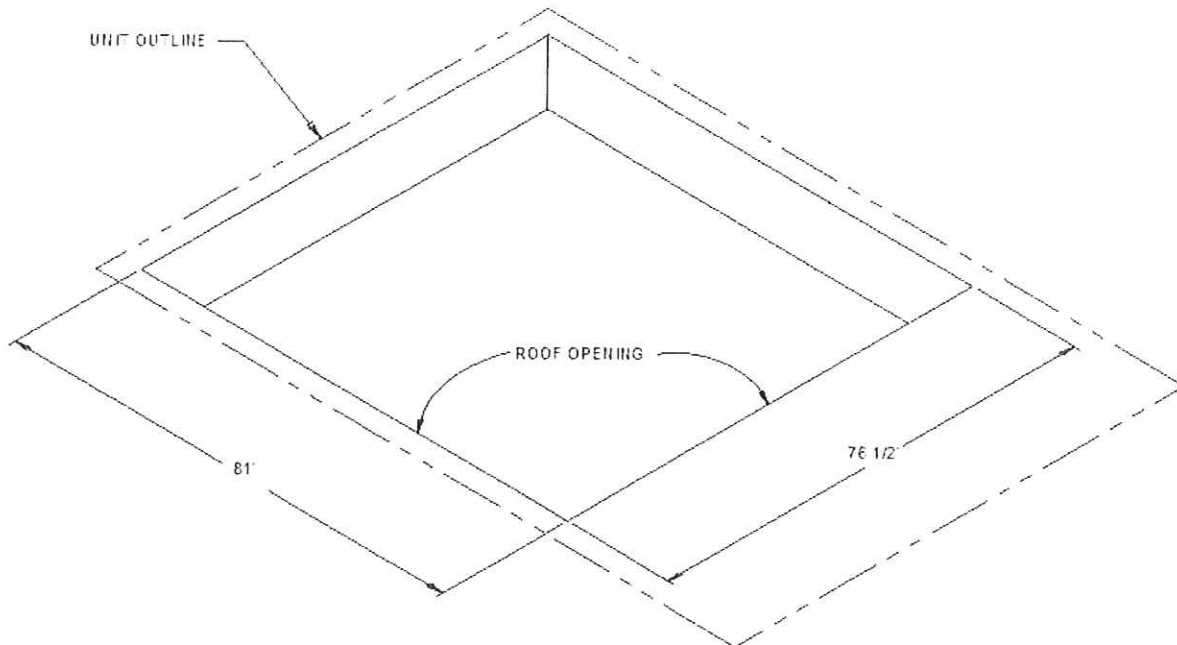

DOWNFLOW-PACKAGED COOLING WITH ELECTRIC ROOF OPENING CLEARANCE

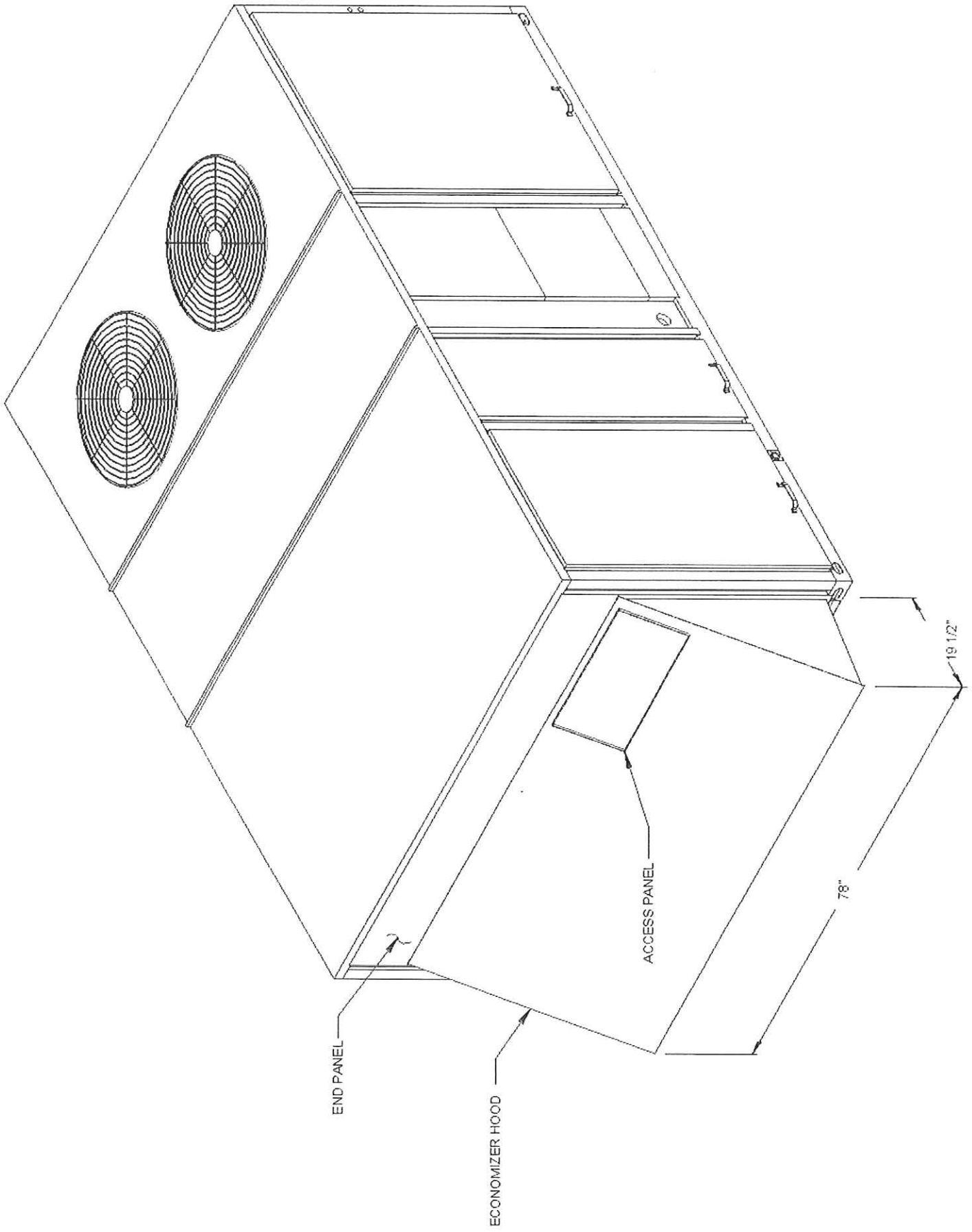

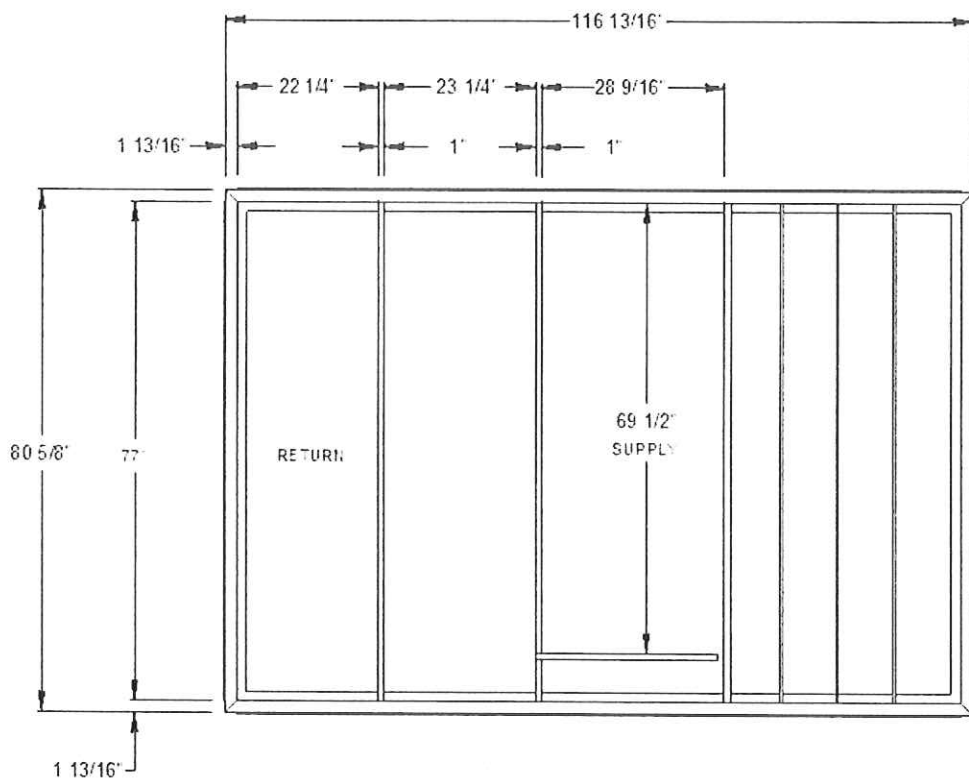

UNIT ROOF CURB  
ACCESSORY DRAWING

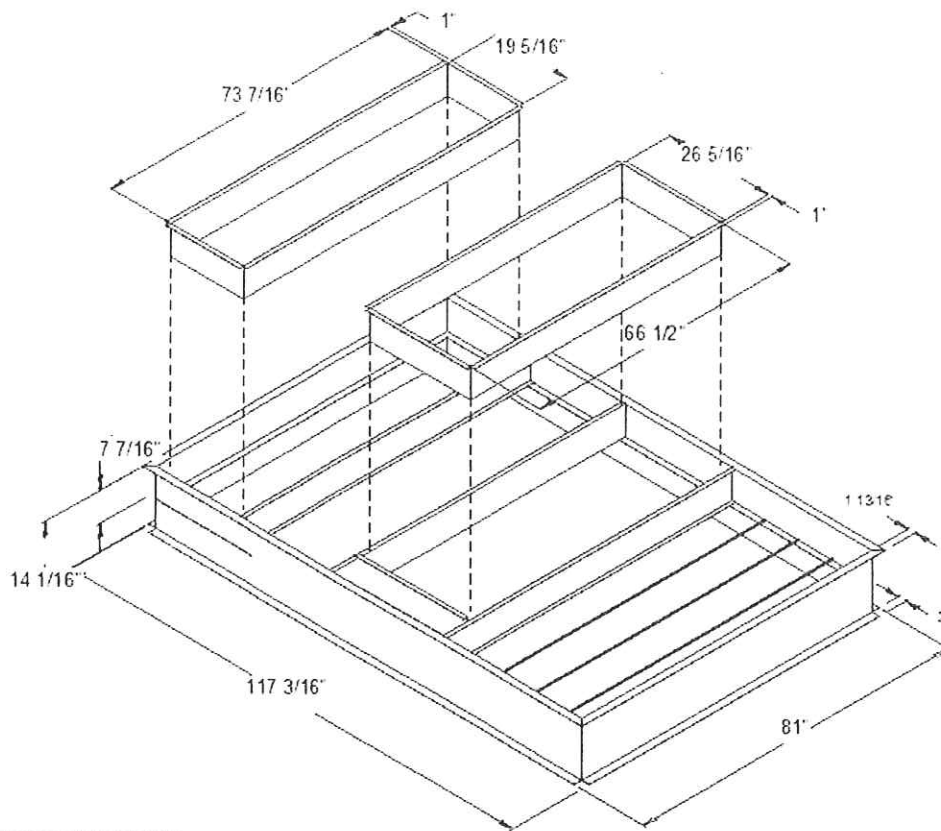

DOWNFLOW DUCT CONNECTIONS  
ACCESSORY DRAWING

### **General (R-410A)**

The units shall be dedicated downflow or horizontal airflow. The operating range shall be between 115F and 0F in cooling as standard from the factory for all units. Cooling performance shall be rated in accordance with AHRI testing procedures. All units shall be factory assembled, internally wired, fully charged with R-410A, and 100 percent run tested to check cooling operation, fan and blower rotation and control sequence, before leaving the factory. Wiring internal to the unit shall be colored and numbered for simplified identification. Units shall be UL listed and labeled, classified in accordance to UL 1995/C 22.2, 236-05 3rd Edition.

### **Casing (R-410A)**

Unit casing shall be constructed of zinc coated, heavy gauge, galvanized steel. Exterior surfaces shall be cleaned, phosphatized, and finished with a weather-resistant baked enamel finish. Unit's surface shall be tested 672 hours in a salt spray test in compliance with ASTM B117. Cabinet construction shall allow for all maintenance on one side of the unit. In order to ensure a water and air tight seal, service panels shall have lifting handles and no more than three screws to remove. All exposed vertical panels and top covers in the indoor air section shall be insulated with a 1/2", 1 pound density foil-faced, fire-resistant, permanent, odorless, glass fiber material. The base of the downflow unit shall be insulated with 1/2", 1 pound density foil-faced, closed-cell material. The downflow unit's base pan shall have no penetrations within the perimeter of the curb other than the raised 1 1/8" high supply/return openings to provide an added water integrity precaution, if the condensate drain backs up. The base of the unit shall have provisions for forklift and crane lifting.

### **Unit Top (R-410A)**

The top cover shall be one piece, or where seams exist, double hemmed and gasket sealed to prevent water leakage.

### **Filters (R-410A)**

Two inch standard filters shall be factory supplied on all units. Optional two inch pleated media filters shall be available.

### **Compressors (R-410A)**

All units shall have direct-drive, hermetic, scroll type compressors with centrifugal type oil pumps. Motor shall be suction gas-cooled and shall have a voltage utilization range of plus or minus 10 percent of nameplate voltage. Internal overloads shall be provided with the scroll compressors. All models shall have crankcase heaters, phase monitors and low and high pressure control as standard.

### **Crankcase Heaters (R-410A)**

These band heaters provide improved compressor reliability by warming the oil to prevent migration during off-cycles or low ambient conditions. These are standard on all Voyager models.

### **Refrigerant Circuits (R-410A)**

Each refrigerant circuit shall have independent fixed orifice or thermostatic expansion devices, service pressure ports, and refrigerant line filter driers factory installed as standard. An area shall be provided for replacement suction line driers.

### **High Pressure Cutout (R-410A)**

This option is offered for units that do not have High Pressure cutout as standard.

### **Microchannel coils**

The microchannel type condenser coil is standard for the T/YCD 12.5-25 ton standard efficiency models. Due to flat streamlined tubes with small ports, and metallurgical tube-to-fin bond, microchannel coil has better heat transfer performance. Microchannel condenser coil can reduce system refrigerant charge by up to 50% because of smaller internal volume, which leads to better compressor reliability. Compact all-aluminum

microchannel coils more dust resistant and easier to clean. Coils shall be leak tested at the factory to ensure the pressure integrity. The evaporator coil and condenser coil shall be leak tested to 600 psig. The assembled unit shall be leak tested to 465 psig.

### **Outdoor Fans (R-410A)**

The outdoor fan shall be direct-drive, statically and dynamically balanced, draw-through in the vertical discharge position. The fan motor(s) shall be permanently lubricated and shall have built-in thermal overload protection.

### **Indoor Fan (R-410A)**

Units above shall have belt driven, FC centrifugal fans with adjustable motor sheaves. Units with standard motors shall have an adjustable idler-arm assembly for quick-adjustment of fan belts and motor sheaves. All motors shall be thermally protected. Oversized motors shall be available for high static application. All indoor fan motors meet the U.S. Energy Policy Act of 1992 (EPACT).

### **Controls (R-410A)**

Unit shall be completely factory wired with necessary controls and contactor pressure lugs or terminal block for power wiring. Unit shall provide an external location for mounting a fused disconnect device. ReliaTel controls shall be provided for all 24 volt control functions. The resident control algorithms shall make all heating, cooling, and/or ventilating decisions in response to electronic signals from sensors measuring indoor and outdoor temperatures. The control algorithm maintains accurate temperature control, minimizes drift from set point, and provides better building comfort. A centralized control shall provide anti-short cycle timing and time delay between compressors to provide a higher level of machine protection.

### **Discharge Line Thermostat (R410A)**

A bi-metal element discharge line thermostat is installed as a standard option on the discharge line of each system. This standard option provides extra protection to the compressors against high discharge temperatures in case of loss of charge, extremely high ambient and other conditions which could drive the discharge temperature higher. Discharge line thermostat is wired in series with high pressure control. When the discharge temperature rises above the protection limit, the bi-metal disc in the thermostat switches to the off position, opening the 24 VAC circuit. When the temperature on the discharge line cools down, the bi-metal disc closes the contactor circuit, providing power to the compressor. When the thermostat opens the fourth time, the ReliaTel control must be manually reset to resume operation on that stage.

### **Accessory - Roof Curb - Downflow (R-410A)**

The roof curb shall be designed to mate with the downflow unit and provide support and a water tight installation when installed properly. The roof curb design shall allow field-fabricated rectangular supply/return ductwork to be connected directly to the curb. Curb design shall comply with NRCA requirements. Curb shall be shipped knocked down for field assembly and shall include wood nailer strips.

### **Accessory - Economizer - Downflow (R-410A)**

The assembly includes fully modulating 0-100 percent motor and dampers, barometric relief, minimum position setting, preset linkage, wiring harness with plug, fixed dry bulb and spring return actuator. The barometric relief damper shall be standard with the downflow economizer and shall provide a pressure operated damper that shall be gravity closing and shall prohibit entrance of outside air during the equipment "off" cycle. Solid state enthalpy and differential enthalpy control shall be field-installed.

### **Accessory - Electric Heaters (R-410A)**

Electric heat modules shall be available for installation within the basic unit. Electric heater elements shall be constructed of heavy-duty nickel chromium elements internally delta connected for 240 volt, wye connected for 480 and 600 volt. Staging shall be achieved through ReliaTel. Each heater package shall have automatically reset high limit control operating through heating element contactors. All heaters shall be individually fused from the factory, where required, and shall meet all NEC and CEC requirements when properly installed. Power assemblies shall provide single-point connection. Electric heat modules shall be UL listed or CSA certified. If ordering the Through the Base Electrical option with an Electric Heater, the heater must be factory installed. 122 RT-PRC028-EN