



State of West Virginia
 Department of Administration
 Purchasing Division
 2019 Washington Street East
 Post Office Box 50130
 Charleston, WV 25305-0130

Solicitation

NUMBER
COR61512

PAGE
1

ADDRESS CORRESPONDENCE TO ATTENTION OF:
TARA LYLE 304-558-2544

RFQ COPY
 TYPE NAME/ADDRESS HERE

VENDOR

Danhill Construction Company
 PO Box 685
 Gauley Bridge, WV 25085

SHIP TO

DENMAR CORRECTIONAL CENTER
 HC-64, BOX 125
 DENMAR ROAD
 HILLSBORO, WV
 24946

DATE PRINTED
07/31/2013

BID OPENING DATE: 08/15/2013 BID OPENING TIME 1:30PM

LINE	QUANTITY	UOP	CAT NO.	ITEM NUMBER	UNIT PRICE	AMOUNT
***** PLEASE NOTE A MANDATORY PRE-BID MEETING IS SCHEDULED FOR 08/06/2013 AT 11:00 AM AT THE DENMAR CORRECTIONAL CENTER LOCATED AT HC64 BOX 125 HILLSBORO, WV 24946. ***** PLEASE NOTE: THE DRUG FREE WORKPLACE AFFIDAVIT AND BID BOND ARE REQUIRED WITH BID SUBMISSION. ***** VENDORS MAY PICK-UP COPIES OF THE CONTRACT DOCUMENTS AT THE OFFICE OF S & S ENGINEERS, INC., LOCATED AT 501 EAGLE MOUNTAIN ROAD CHARLESTON, WV 25311. THERE IS A NON-REFUNDABLE \$200.00 CHARGE FOR THE CONTRACT DOCUMENTS. MAILED CONTRACT DOCUMENTS WILL BE CHARGED AN ADDITIONAL NON-REFUNDABLE FEE OF \$35.00. FOR MORE INFORMATION, CONTACT S & S ENGINEERS, INC. AT 304-342-7168. *****						
0001	1	JB	968-42	REMOVAL/INSTALL OF WATER STORAGE TANKS		
					08/29/13 11:38:15 AM	West Virginia Purchasing Division
THE WEST VIRGINIA PURCHASING DIVISION FOR THE AGENCY, WV DIVISION OF CORRECTIONS - DENMAR CORRECTIONAL CENTER, IS SOLICITING BIDS TO REMOVE						
SIGNATURE <i>Robert D. Hill</i>				TELEPHONE (304) 632-1600	DATE 8/29/2013	
TITLE PRESIDENT		FERN 55-0648251		ADDRESS CHANGES TO BE NOTED ABOVE		

WHEN RESPONDING TO SOLICITATION, INSERT NAME AND ADDRESS IN SPACE ABOVE LABELED 'VENDOR'



State of West Virginia
 Department of Administration
 Purchasing Division
 2019 Washington Street East
 Post Office Box 50130
 Charleston, WV 25305-0130

Solicitation

NUMBER
COR61512

PAGE
2

ADDRESS CORRESPONDENCE TO ATTENTION OF:
TARA LYLE
304-558-2544

VENDOR

RFQ COPY
 TYPE NAME/ADDRESS HERE

Danhill Construction Company
 PO Box 685
 Gauley Bridge, WV 25085

SHIP TO

DENMAR CORRECTIONAL CENTER
 HC-64, BOX 125
 DENMAR ROAD
 HILLSBORO, WV
 24946

DATE PRINTED
07/31/2013

BID OPENING DATE: 08/15/2013 BID OPENING TIME 1:30PM

LINE	QUANTITY	UOP	CAT NO.	ITEM NUMBER	UNIT PRICE	AMOUNT
				TWO (2) EXISTING WATER STORAGE TANKS AND INSTALL ONE (1) NEW WATER STORAGE TANK AT THE DENMAR CORRECTIONAL COMPLEX LOCATED AT HC64, BOX 125 HILLSBORO, WV 24949, PER THE ATTACHED SPECIFICATIONS. ATTACHMENTS INCLUDE: 1. INSTRUCTIONS TO VENDORS SUBMITTING BIDS 2. GENERAL TERMS AND CONDITIONS 3. ADDITIONAL TERMS AND CONDITIONS (CONSTRUCTION CONTRACTS ONLY) 4. COR61512 SPECIFICATIONS 5. CERTIFICATION AND SIGNATURE PAGE 6. ADDENDUM ACKNOWLEDGEMENT FORM 7. PURCHASING AFFIDAVIT 8. BID BOND INSTRUCTIONS AND FORM 9. DRUG-FREE WORKPLACE AFFIDAVIT 10. WV-75-CONSTRUCTION BID SUBMISSION REVIEW FORM ***** THIS IS THE END OF RFQ COR61512 ***** TOTAL: _____ ***** Denmar Correctional Center Water Storage Tank Replacement Project - Installation of a new 300,000 gallon above ground water storage tank to replace the existing water storage tanks and two (2) high service pumps with control panel at the Denmar Correctional Center. *****		

SIGNATURE <i>Robert D. Hill</i>	TELEPHONE (304)632-1600	DATE 8/29/2013
TITLE <i>PRESIDENT</i>	FEIN 55-0648251	ADDRESS CHANGES TO BE NOTED ABOVE

WHEN RESPONDING TO SOLICITATION, INSERT NAME AND ADDRESS IN SPACE ABOVE LABELED 'VENDOR'

INSTRUCTIONS TO VENDORS SUBMITTING BIDS

1. **REVIEW DOCUMENTS THOROUGHLY:** The attached documents contain a solicitation for bids. Please read these instructions and all documents attached in their entirety. These instructions provide critical information about requirements that if overlooked could lead to disqualification of a Vendor's bid. All bids must be submitted in accordance with the provisions contained in these instructions and the Solicitation. Failure to do so may result in disqualification of Vendor's bid.
2. **MANDATORY TERMS:** The Solicitation may contain mandatory provisions identified by the use of the words "must," "will," and "shall." Failure to comply with a mandatory term in the Solicitation will result in bid disqualification.
3. **PREBID MEETING:** The item identified below shall apply to this Solicitation.

- A pre-bid meeting will not be held prior to bid opening.
- A NON-MANDATORY PRE-BID meeting will be held at the following place and time:

- A MANDATORY PRE-BID meeting will be held at the following place and time:
August 6, 2013 at 11:00 am

Location:
Denmar Correctional Center
HC64, Box 125
Hillsboro, WV 24946

All Vendors submitting a bid must attend the mandatory pre-bid meeting. Failure to attend the mandatory pre-bid meeting shall result in disqualification of the Vendor's bid. No one person attending the pre-bid meeting may represent more than one Vendor.

An attendance sheet provided at the pre-bid meeting shall serve as the official document verifying attendance. The State will not accept any other form of proof or documentation to verify attendance. Any person attending the pre-bid meeting on behalf of a Vendor must list on the attendance sheet his or her name and the name of the Vendor he or she is representing. Additionally, the person attending the pre-bid meeting should include the Vendor's E-Mail address, phone number, and Fax number on the attendance sheet. It is the Vendor's responsibility to locate the attendance sheet and provide the required

information. Failure to complete the attendance sheet as required may result in disqualification of Vendor's bid.

All Vendors should arrive prior to the starting time for the pre-bid. Vendors who arrive after the starting time but prior to the end of the pre-bid will be permitted to sign in, but are charged with knowing all matters discussed at the pre-bid.

Questions submitted at least five business days prior to a scheduled pre-bid will be discussed at the pre-bid meeting if possible. Any discussions or answers to questions at the pre-bid meeting are preliminary in nature and are non-binding. Official and binding answers to questions will be published in a written addendum to the Solicitation prior to bid opening.

4. **VENDOR QUESTION DEADLINE:** Vendors may submit questions relating to this Solicitation to the Purchasing Division. Questions must be submitted in writing. All questions must be submitted on or before the date listed below and to the address listed below in order to be considered. A written response will be published in a Solicitation addendum if a response is possible and appropriate. Non-written discussions, conversations, or questions and answers regarding this Solicitation are preliminary in nature and are non-binding.

Question Submission Deadline: August 7, 2013 at 5:00 pm

Submit Questions to: Tara Lyle, File 32
2019 Washington Street, East
Charleston, WV 25305
Fax: 304-558-4115
Email: Tara.L.Lyle@wv.gov

5. **VERBAL COMMUNICATION:** Any verbal communication between the Vendor and any State personnel is not binding, including that made at the mandatory pre-bid conference. Only information issued in writing and added to the Solicitation by an official written addendum by the Purchasing Division is binding.
6. **BID SUBMISSION:** All bids must be signed and delivered by the Vendor to the Purchasing Division at the address listed below on or before the date and time of the bid opening. Any bid received by the Purchasing Division staff is considered to be in the possession of the Purchasing Division and will not be returned for any reason. The bid delivery address is:

Department of Administration, Purchasing Division
2019 Washington Street East
Charleston, WV 25305-0130

The bid should contain the information listed below on the face of the envelope or the bid may not be considered:

SEALED BID

BUYER: _____
 SOLICITATION NO.: _____
 BID OPENING DATE: _____
 BID OPENING TIME: _____
 FAX NUMBER: _____

In the event that Vendor is responding to a request for proposal, the Vendor shall submit one original technical and one original cost proposal plus n/a convenience copies of each to the Purchasing Division at the address shown above. Additionally, the Vendor should identify the bid type as either a technical or cost proposal on the face of each bid envelope submitted in response to a request for proposal as follows:

BID TYPE: Technical
 Cost

7. **BID OPENING:** Bids submitted in response to this Solicitation will be opened at the location identified below on the date and time listed below. Delivery of a bid after the bid opening date and time will result in bid disqualification. For purposes of this Solicitation, a bid is considered delivered when time stamped by the official Purchasing Division time clock.

Bid Opening Date and Time: August 15, 2013 at 1:30 pm

Bid Opening Location: Department of Administration, Purchasing Division
 2019 Washington Street East
 Charleston, WV 25305-0130

8. **ADDENDUM ACKNOWLEDGEMENT:** Changes or revisions to this Solicitation will be made by an official written addendum issued by the Purchasing Division. Vendor should acknowledge receipt of all addenda issued with this Solicitation by completing an Addendum Acknowledgment Form, a copy of which is included herewith. Failure to acknowledge addenda may result in bid disqualification. The addendum acknowledgement should be submitted with the bid to expedite document processing.
9. **BID FORMATTING:** Vendor should type or electronically enter the information onto its bid to prevent errors in the evaluation. Failure to type or electronically enter the information may result in bid disqualification.

GENERAL TERMS AND CONDITIONS:

1. **CONTRACTUAL AGREEMENT:** Issuance of a Purchase Order signed by the Purchasing Division Director, or his designee, and approved as to form by the Attorney General's office constitutes acceptance of this Contract made by and between the State of West Virginia and the Vendor. Vendor's signature on its bid signifies Vendor's agreement to be bound by and accept the terms and conditions contained in this Contract.

2. **DEFINITIONS:** As used in this Solicitation / Contract, the following terms shall have the meanings attributed to them below. Additional definitions may be found in the specifications included with this Solicitation / Contract.
 - 2.1 **"Agency"** or **"Agencies"** means the agency, board, commission, or other entity of the State of West Virginia that is identified on the first page of the Solicitation or any other public entity seeking to procure goods or services under this Contract.
 - 2.2 **"Contract"** means the binding agreement that is entered into between the State and the Vendor to provide the goods and services requested in the Solicitation.
 - 2.3 **"Director"** means the Director of the West Virginia Department of Administration, Purchasing Division.
 - 2.4 **"Purchasing Division"** means the West Virginia Department of Administration, Purchasing Division.
 - 2.5 **"Purchase Order"** means the document signed by the Agency and the Purchasing Division, and approved as to form by the Attorney General, that identifies the Vendor as the successful bidder and Contract holder.
 - 2.6 **"Solicitation"** means the official solicitation published by the Purchasing Division and identified by number on the first page thereof.
 - 2.7 **"State"** means the State of West Virginia and/or any of its agencies, commissions, boards, etc. as context requires.
 - 2.8 **"Vendor"** or **"Vendors"** means any entity submitting a bid in response to the Solicitation, the entity that has been selected as the lowest responsible bidder, or the entity that has been awarded the Contract as context requires.

3. **CONTRACT TERM; RENEWAL; EXTENSION:** The term of this Contract shall be determined in accordance with the category that has been identified as applicable to this Contract below:

Term Contract

Initial Contract Term: This Contract becomes effective on _____
and extends for a period of _____ year(s).

Renewal Term: This Contract may be renewed upon the mutual written consent of the Agency, and the Vendor, with approval of the Purchasing Division and the Attorney General's office (Attorney General approval is as to form only). Any request for renewal must be submitted to the Purchasing Division Director thirty (30) days prior to the expiration date of the initial contract term or appropriate renewal term. A Contract renewal shall be in accordance with the terms and conditions of the original contract. Renewal of this Contract is limited to _____ successive one (1) year periods. Automatic renewal of this Contract is prohibited. Notwithstanding the foregoing, Purchasing Division approval is not required on agency delegated or exempt purchases. Attorney General approval may be required for vendor terms and conditions.

Reasonable Time Extension: At the sole discretion of the Purchasing Division Director, and with approval from the Attorney General's office (Attorney General approval is as to form only), this Contract may be extended for a reasonable time after the initial Contract term or after any renewal term as may be necessary to obtain a new contract or renew this Contract. Any reasonable time extension shall not exceed twelve (12) months. Vendor may avoid a reasonable time extension by providing the Purchasing Division Director with written notice of Vendor's desire to terminate this Contract 30 days prior to the expiration of the then current term. During any reasonable time extension period, the Vendor may terminate this Contract for any reason upon giving the Purchasing Division Director 30 days written notice. Automatic extension of this Contract is prohibited. Notwithstanding the foregoing, Purchasing Division approval is not required on agency delegated or exempt purchases, but Attorney General approval may be required.

Release Order Limitations: In the event that this contract permits release orders, a release order may only be issued during the time this Contract is in effect. Any release order issued within one year of the expiration of this Contract shall be effective for one year from the date the release order is issued. No release order may be extended beyond one year after this Contract has expired.

Fixed Period Contract: This Contract becomes effective upon Vendor's receipt of the notice to proceed and must be completed within _____ 60 _____ days.

- One Time Purchase:** The term of this Contract shall run from the issuance of the Purchase Order until all of the goods contracted for have been delivered, but in no event shall this Contract extend for more than one fiscal year.
- Other:** See attached.
4. **NOTICE TO PROCEED:** Vendor shall begin performance of this Contract immediately upon receiving notice to proceed unless otherwise instructed by the Agency. Unless otherwise specified, the fully executed Purchase Order will be considered notice to proceed
5. **QUANTITIES:** The quantities required under this Contract shall be determined in accordance with the category that has been identified as applicable to this Contract below.
- Open End Contract:** Quantities listed in this Solicitation are approximations only, based on estimates supplied by the Agency. It is understood and agreed that the Contract shall cover the quantities actually ordered for delivery during the term of the Contract, whether more or less than the quantities shown.
- Service:** The scope of the service to be provided will be more clearly defined in the specifications included herewith.
- Combined Service and Goods:** The scope of the service and deliverable goods to be provided will be more clearly defined in the specifications included herewith.
- One Time Purchase:** This Contract is for the purchase of a set quantity of goods that are identified in the specifications included herewith. Once those items have been delivered, no additional goods may be procured under this Contract without an appropriate change order approved by the Vendor, Agency, Purchasing Division, and Attorney General's office.
6. **PRICING:** The pricing set forth herein is firm for the life of the Contract, unless specified elsewhere within this Solicitation/Contract by the State. A Vendor's inclusion of price adjustment provisions in its bid, without an express authorization from the State in the Solicitation to do so, may result in bid disqualification.
7. **EMERGENCY PURCHASES:** The Purchasing Division Director may authorize the Agency to purchase goods or services in the open market that Vendor would otherwise provide under this Contract if those goods or services are for immediate or expedited delivery in an emergency. Emergencies shall include, but are not limited to, delays in transportation or an unanticipated increase in the volume of work. An emergency purchase in the open market, approved by the Purchasing Division Director, shall not constitute of breach of this Contract and shall not entitle the Vendor to any form of compensation or damages. This provision does not excuse the State from fulfilling its obligations under a One Time Purchase contract.
8. **REQUIRED DOCUMENTS:** All of the items checked below must be provided to the Purchasing Division by the Vendor as specified below.

- BID BOND:** All Vendors shall furnish a bid bond in the amount of five percent (5%) of the total amount of the bid protecting the State of West Virginia. The bid bond must be submitted with the bid.
- PERFORMANCE BOND:** The apparent successful Vendor shall provide a performance bond in the amount of 100% of contract value . The performance bond must be issued and received by the Purchasing Division prior to Contract award. On construction contracts, the performance bond must be 100% of the Contract value.
- LABOR/MATERIAL PAYMENT BOND:** The apparent successful Vendor shall provide a labor/material payment bond in the amount of 100% of the Contract value. The labor/material payment bond must be issued and delivered to the Purchasing Division prior to Contract award.

In lieu of the Bid Bond, Performance Bond, and Labor/Material Payment Bond, the Vendor may provide certified checks, cashier's checks, or irrevocable letters of credit. Any certified check, cashier's check, or irrevocable letter of credit provided in lieu of a bond must be of the same amount and delivered on the same schedule as the bond it replaces. A letter of credit submitted in lieu of a performance and labor/material payment bond will only be allowed for projects under \$100,000. Personal or business checks are not acceptable.

- MAINTENANCE BOND:** The apparent successful Vendor shall provide a two (2) year maintenance bond covering the roofing system. The maintenance bond must be issued and delivered to the Purchasing Division prior to Contract award.
- WORKERS' COMPENSATION INSURANCE:** The apparent successful Vendor shall have appropriate workers' compensation insurance and shall provide proof thereof upon request.
- INSURANCE:** The apparent successful Vendor shall furnish proof of the following insurance prior to Contract award and shall list the state as a certificate holder:

- Commercial General Liability Insurance:**
\$1,000,000.00 or more.
- Builders Risk Insurance:** builders risk – all risk insurance in an amount equal to 100% of the amount of the Contract.
-
-
-
-
-

The apparent successful Vendor shall also furnish proof of any additional insurance requirements contained in the specifications prior to Contract award regardless of whether or not that insurance requirement is listed above.

LICENSE(S) / CERTIFICATIONS / PERMITS: In addition to anything required under the Section entitled Licensing, of the General Terms and Conditions, the apparent successful Vendor shall furnish proof of the following licenses, certifications, and/or permits prior to Contract award, in a form acceptable to the Purchasing Division.

WV Contractor's License

The apparent successful Vendor shall also furnish proof of any additional licenses or certifications contained in the specifications prior to Contract award regardless of whether or not that requirement is listed above.

9. LITIGATION BOND: The Director reserves the right to require any Vendor that files a protest of an award to submit a litigation bond in the amount equal to one percent of the lowest bid submitted or \$5,000, whichever is greater. The entire amount of the bond shall be forfeited if the hearing officer determines that the protest was filed for frivolous or improper purpose, including but not limited to, the purpose of harassing, causing unnecessary delay, or needless expense for the Agency. All litigation bonds shall be made payable to the Purchasing Division. In lieu of a bond, the protester may submit a cashier's check or certified check payable to the Purchasing Division. Cashier's or certified checks will be deposited with and held by the State Treasurer's office. If it is determined that the protest has not been filed for frivolous or improper purpose, the bond or deposit shall be returned in its entirety.

10. ALTERNATES: Any model, brand, or specification listed herein establishes the acceptable level of quality only and is not intended to reflect a preference for, or in any way favor, a particular brand or vendor. Vendors may bid alternates to a listed model or brand provided that the alternate is at least equal to the model or brand and complies with the required specifications. The equality of any alternate being bid shall be determined by the State at its sole discretion. Any Vendor bidding an alternate model or brand should clearly identify the alternate items in its bid and should include manufacturer's specifications, industry literature, and/or any other relevant documentation demonstrating the equality of the alternate items. Failure to provide information for alternate items may be grounds for rejection of a Vendor's bid.

11. EXCEPTIONS AND CLARIFICATIONS: The Solicitation contains the specifications that shall form the basis of a contractual agreement. Vendor shall clearly mark any exceptions, clarifications, or

other proposed modifications in its bid. Exceptions to, clarifications of, or modifications of a requirement or term and condition of the Solicitation may result in bid disqualification.

12. LIQUIDATED DAMAGES: Vendor shall pay liquidated damages in the amount
for

This clause shall in no way be considered exclusive and shall not limit the State or Agency's right to pursue any other available remedy.

13. ACCEPTANCE/REJECTION: The State may accept or reject any bid in whole, or in part. Vendor's signature on its bid signifies acceptance of the terms and conditions contained in the Solicitation and Vendor agrees to be bound by the terms of the Contract, as reflected in the Purchase Order, upon receipt.

14. REGISTRATION: Prior to Contract award, the apparent successful Vendor must be properly registered with the West Virginia Purchasing Division and must have paid the \$125 fee if applicable.

15. COMMUNICATION LIMITATIONS: In accordance with West Virginia Code of State Rules §148-1-6.6, communication with the State of West Virginia or any of its employees regarding this Solicitation during the solicitation, bid, evaluation or award periods, except through the Purchasing Division, is strictly prohibited without prior Purchasing Division approval. Purchasing Division approval for such communication is implied for all agency delegated and exempt purchases.

16. FUNDING: This Contract shall continue for the term stated herein, contingent upon funds being appropriated by the Legislature or otherwise being made available. In the event funds are not appropriated or otherwise made available, this Contract becomes void and of no effect beginning on July 1 of the fiscal year for which funding has not been appropriated or otherwise made available.

17. PAYMENT: Payment in advance is prohibited under this Contract. Payment may only be made after the delivery and acceptance of goods or services. The Vendor shall submit invoices, in arrears, to the Agency at the address on the face of the purchase order labeled "Invoice To."

18. UNIT PRICE: Unit prices shall prevail in cases of a discrepancy in the Vendor's bid.

19. DELIVERY: All quotations are considered freight on board destination ("F.O.B. destination") unless alternate shipping terms are clearly identified in the bid. Vendor's listing of shipping terms that contradict the shipping terms expressly required by this Solicitation may result in bid disqualification.

20. INTEREST: Interest attributable to late payment will only be permitted if authorized by the West Virginia Code. Presently, there is no provision in the law for interest on late payments.

21. PREFERENCE: Vendor Preference may only be granted upon written request and only in accordance with the West Virginia Code § 5A-3-37 and the West Virginia Code of State Rules. A Resident Vendor Certification form has been attached hereto to allow Vendor to apply for the preference. Vendor's

failure to submit the Resident Vendor Certification form with its bid will result in denial of Vendor Preference. Vendor Preference does not apply to construction projects.

22. **SMALL, WOMEN-OWNED, OR MINORITY-OWNED BUSINESSES:** For any solicitations publicly advertised for bid on or after July 1, 2012, in accordance with West Virginia Code §5A-3-37(a)(7) and W. Va. CSR § 148-22-9, any non-resident vendor certified as a small, women-owned, or minority-owned business under W. Va. CSR § 148-22-9 shall be provided the same preference made available to any resident vendor. Any non-resident small, women-owned, or minority-owned business must identify itself as such in writing, must submit that writing to the Purchasing Division with its bid, and must be properly certified under W. Va. CSR § 148-22-9 prior to submission of its bid to receive the preferences made available to resident vendors. Preference for a non-resident small, women-owned, or minority owned business shall be applied in accordance with W. Va. CSR § 148-22-9.
23. **TAXES:** The Vendor shall pay any applicable sales, use, personal property or any other taxes arising out of this Contract and the transactions contemplated thereby. The State of West Virginia is exempt from federal and state taxes and will not pay or reimburse such taxes.
24. **CANCELLATION:** The Purchasing Division Director reserves the right to cancel this Contract immediately upon written notice to the vendor if the materials or workmanship supplied do not conform to the specifications contained in the Contract. The Purchasing Division Director may cancel any purchase or Contract upon 30 days written notice to the Vendor in accordance with West Virginia Code of State Rules § 148-1-7.16.2.
25. **WAIVER OF MINOR IRREGULARITIES:** The Director reserves the right to waive minor irregularities in bids or specifications in accordance with West Virginia Code of State Rules § 148-1-4.6.
26. **TIME:** Time is of the essence with regard to all matters of time and performance in this Contract.
27. **APPLICABLE LAW:** This Contract is governed by and interpreted under West Virginia law without giving effect to its choice of law principles. Any information provided in specification manuals, or any other source, verbal or written, which contradicts or violates the West Virginia Constitution, West Virginia Code or West Virginia Code of State Rules is void and of no effect.
28. **COMPLIANCE:** Vendor shall comply with all applicable federal, state, and local laws, regulations and ordinances. By submitting a bid, Vendors acknowledge that they have reviewed, understand, and will comply with all applicable law.
29. **PREVAILING WAGE:** On any contract for the construction of a public improvement, Vendor and any subcontractors utilized by Vendor shall pay a rate or rates of wages which shall not be less than the fair minimum rate or rates of wages (prevailing wage), as established by the West Virginia Division of Labor under West Virginia Code §§ 21-5A-1 et seq. and available at <http://www.sos.wv.gov/administrative-law/wagerates/Pages/default.aspx>. Vendor shall be responsible for ensuring compliance with prevailing wage requirements and determining when prevailing wage

requirements are applicable. The required contract provisions contained in West Virginia Code of State Rules § 42-7-3 are specifically incorporated herein by reference.

- 30. ARBITRATION:** Any references made to arbitration contained in this Contract, Vendor's bid, or in any American Institute of Architects documents pertaining to this Contract are hereby deleted, void, and of no effect.
- 31. MODIFICATIONS:** This writing is the parties' final expression of intent. Notwithstanding anything contained in this Contract to the contrary, no modification of this Contract shall be binding without mutual written consent of the Agency, and the Vendor, with approval of the Purchasing Division and the Attorney General's office (Attorney General approval is as to form only). **No Change shall be implemented by the Vendor until such time as the Vendor receives an approved written change order from the Purchasing Division.**
- 32. WAIVER:** The failure of either party to insist upon a strict performance of any of the terms or provision of this Contract, or to exercise any option, right, or remedy herein contained, shall not be construed as a waiver or a relinquishment for the future of such term, provision, option, right, or remedy, but the same shall continue in full force and effect. Any waiver must be expressly stated in writing and signed by the waiving party.
- 33. SUBSEQUENT FORMS:** The terms and conditions contained in this Contract shall supersede any and all subsequent terms and conditions which may appear on any form documents submitted by Vendor to the Agency or Purchasing Division such as price lists, order forms, invoices, sales agreements, or maintenance agreements, and includes internet websites or other electronic documents. Acceptance or use of Vendor's forms does not constitute acceptance of the terms and conditions contained thereon.
- 34. ASSIGNMENT:** Neither this Contract nor any monies due, or to become due hereunder, may be assigned by the Vendor without the express written consent of the Agency, the Purchasing Division, the Attorney General's office (as to form only), and any other government agency or office that may be required to approve such assignments. Notwithstanding the foregoing, Purchasing Division approval may or may not be required on certain agency delegated or exempt purchases.
- 35. WARRANTY:** The Vendor expressly warrants that the goods and/or services covered by this Contract will: (a) conform to the specifications, drawings, samples, or other description furnished or specified by the Agency; (b) be merchantable and fit for the purpose intended; and (c) be free from defect in material and workmanship.
- 36. STATE EMPLOYEES:** State employees are not permitted to utilize this Contract for personal use and the Vendor is prohibited from permitting or facilitating the same.
- 37. BANKRUPTCY:** In the event the Vendor files for bankruptcy protection, the State of West Virginia may deem this Contract null and void, and terminate this Contract without notice.

38. [RESERVED]

39. CONFIDENTIALITY: The Vendor agrees that it will not disclose to anyone, directly or indirectly, any such personally identifiable information or other confidential information gained from the Agency, unless the individual who is the subject of the information consents to the disclosure in writing or the disclosure is made pursuant to the Agency's policies, procedures, and rules. Vendor further agrees to comply with the Confidentiality Policies and Information Security Accountability Requirements, set forth in <http://www.state.wv.us/admin/purchase/privacy/default.html>.

40. DISCLOSURE: Vendor's response to the Solicitation and the resulting Contract are considered public documents and will be disclosed to the public in accordance with the laws, rules, and policies governing the West Virginia Purchasing Division. Those laws include, but are not limited to, the Freedom of Information Act found in West Virginia Code § 29B-1-1 et seq.

If a Vendor considers any part of its bid to be exempt from public disclosure, Vendor must so indicate by specifically identifying the exempt information, identifying the exemption that applies, providing a detailed justification for the exemption, segregating the exempt information from the general bid information, and submitting the exempt information as part of its bid but in a segregated and clearly identifiable format. Failure to comply with the foregoing requirements will result in public disclosure of the Vendor's bid without further notice. A Vendor's act of marking all or nearly all of its bid as exempt is not sufficient to avoid disclosure and WILL NOT BE HONORED. Vendor's act of marking a bid or any part thereof as "confidential" or "proprietary" is not sufficient to avoid disclosure and WILL NOT BE HONORED. In addition, a legend or other statement indicating that all or substantially all of the bid is exempt from disclosure is not sufficient to avoid disclosure and WILL NOT BE HONORED. Vendor will be required to defend any claimed exemption for nondisclosure in the event of an administrative or judicial challenge to the State's nondisclosure. Vendor must indemnify the State for any costs incurred related to any exemptions claimed by Vendor. Any questions regarding the applicability of the various public records laws should be addressed to your own legal counsel prior to bid submission.

41. LICENSING: In accordance with West Virginia Code of State Rules §148-1-6.1.7, Vendor must be licensed and in good standing in accordance with any and all state and local laws and requirements by any state or local agency of West Virginia, including, but not limited to, the West Virginia Secretary of State's Office, the West Virginia Tax Department, West Virginia Insurance Commission, or any other state agency or political subdivision. Upon request, the Vendor must provide all necessary releases to obtain information to enable the Purchasing Division Director or the Agency to verify that the Vendor is licensed and in good standing with the above entities.

42. ANTITRUST: In submitting a bid to, signing a contract with, or accepting a Purchase Order from any agency of the State of West Virginia, the Vendor agrees to convey, sell, assign, or transfer to the State of West Virginia all rights, title, and interest in and to all causes of action it may now or hereafter acquire under the antitrust laws of the United States and the State of West Virginia for price fixing and/or unreasonable restraints of trade relating to the particular commodities or services purchased or acquired by the State of West Virginia. Such assignment shall be made and become effective at the time the

purchasing agency tenders the initial payment to Vendor.

- 43. VENDOR CERTIFICATIONS:** By signing its bid or entering into this Contract, Vendor certifies (1) that its bid was made without prior understanding, agreement, or connection with any corporation, firm, limited liability company, partnership, person or entity submitting a bid for the same material, supplies, equipment or services; (2) that its bid is in all respects fair and without collusion or fraud; (3) that this Contract is accepted or entered into without any prior understanding, agreement, or connection to any other entity that could be considered a violation of law; and (4) that it has reviewed this RFQ in its entirety; understands the requirements, terms and conditions, and other information contained herein. Vendor's signature on its bid also affirms that neither it nor its representatives have any interest, nor shall acquire any interest, direct or indirect, which would compromise the performance of its services hereunder. Any such interests shall be promptly presented in detail to the Agency.

The individual signing this bid on behalf of Vendor certifies that he or she is authorized by the Vendor to execute this bid or any documents related thereto on Vendor's behalf; that he or she is authorized to bind the Vendor in a contractual relationship; and that, to the best of his or her knowledge, the Vendor has properly registered with any State agency that may require registration.

- 44. PURCHASING CARD ACCEPTANCE:** The State of West Virginia currently utilizes a Purchasing Card program, administered under contract by a banking institution, to process payment for goods and services. The Vendor must accept the State of West Virginia's Purchasing Card for payment of all orders under this Contract unless the box below is checked.

Vendor is not required to accept the State of West Virginia's Purchasing Card as payment for all goods and services.

- 45. VENDOR RELATIONSHIP:** The relationship of the Vendor to the State shall be that of an independent contractor and no principal-agent relationship or employer-employee relationship is contemplated or created by this Contract. The Vendor as an independent contractor is solely liable for the acts and omissions of its employees and agents. Vendor shall be responsible for selecting,

supervising, and compensating any and all individuals employed pursuant to the terms of this Solicitation and resulting contract. Neither the Vendor, nor any employees or subcontractors of the Vendor, shall be deemed to be employees of the State for any purpose whatsoever. Vendor shall be exclusively responsible for payment of employees and contractors for all wages and salaries, taxes, withholding payments, penalties, fees, fringe benefits, professional liability insurance premiums, contributions to insurance and pension, or other deferred compensation plans, including but not limited to, Workers' Compensation and Social Security obligations, licensing fees, *etc.* and the filing of all necessary documents, forms and returns pertinent to all of the foregoing. Vendor shall hold harmless the State, and shall provide the State and Agency with a defense against any and all claims including, but not limited to, the foregoing payments, withholdings, contributions, taxes, Social Security taxes, and employer income tax returns.

- 46. INDEMNIFICATION:** The Vendor agrees to indemnify, defend, and hold harmless the State and the Agency, their officers, and employees from and against: (1) Any claims or losses for services rendered

by any subcontractor, person, or firm performing or supplying services, materials, or supplies in connection with the performance of the Contract; (2) Any claims or losses resulting to any person or entity injured or damaged by the Vendor, its officers, employees, or subcontractors by the publication, translation, reproduction, delivery, performance, use, or disposition of any data used under the Contract in a manner not authorized by the Contract, or by Federal or State statutes or regulations; and (3) Any failure of the Vendor, its officers, employees, or subcontractors to observe State and Federal laws including, but not limited to, labor and wage and hour laws.

- 47. PURCHASING AFFIDAVIT:** In accordance with West Virginia Code § 5A-3-10a, all Vendors are required to sign, notarize, and submit the Purchasing Affidavit stating that neither the Vendor nor a related party owe a debt to the State in excess of \$1,000. The affidavit must be submitted prior to award, but should be submitted with the Vendor's bid. A copy of the Purchasing Affidavit is included herewith.
- 48. ADDITIONAL AGENCY AND LOCAL GOVERNMENT USE:** This Contract may be utilized by and extends to other agencies, spending units, and political subdivisions of the State of West Virginia; county, municipal, and other local government bodies; and school districts ("Other Government Entities"). This Contract shall be extended to the aforementioned Other Government Entities on the same prices, terms, and conditions as those offered and agreed to in this Contract. If the Vendor does not wish to extend the prices, terms, and conditions of its bid and subsequent contract to the Other Government Entities, the Vendor must clearly indicate such refusal in its bid. A refusal to extend this Contract to the Other Government Entities shall not impact or influence the award of this Contract in any manner.
- 49. CONFLICT OF INTEREST:** Vendor, its officers or members or employees, shall not presently have or acquire any interest, direct or indirect, which would conflict with or compromise the performance of its obligations hereunder. Vendor shall periodically inquire of its officers, members and employees to ensure that a conflict of interest does not arise. Any conflict of interest discovered shall be promptly presented in detail to the Agency.
- 50. REPORTS:** Vendor shall provide the Agency and/or the Purchasing Division with the following reports identified by a checked box below:
- Such reports as the Agency and/or the Purchasing Division may request. Requested reports may include, but are not limited to, quantities purchased, agencies utilizing the contract, total contract expenditures by agency, etc.
 - Quarterly reports detailing the total quantity of purchases in units and dollars, along with a listing of purchases by agency. Quarterly reports should be delivered to the Purchasing Division via email at purchasing.requisitions@wv.gov.
- 51. BACKGROUND CHECK:** In accordance with W. Va. Code § 15-2D-3, the Director of the Division of Protective Services shall require any service provider whose employees are regularly employed on the grounds or in the buildings of the Capitol complex or who have access to sensitive or critical information to submit to a fingerprint-based state and federal background inquiry through the state

repository. The service provider is responsible for any costs associated with the fingerprint-based state and federal background inquiry.

After the contract for such services has been approved, but before any such employees are permitted to be on the grounds or in the buildings of the Capitol complex or have access to sensitive or critical information, the service provider shall submit a list of all persons who will be physically present and working at the Capitol complex to the Director of the Division of Protective Services for purposes of verifying compliance with this provision.

The State reserves the right to prohibit a service provider's employees from accessing sensitive or critical information or to be present at the Capitol complex based upon results addressed from a criminal background check.

Service providers should contact the West Virginia Division of Protective Services by phone at (304) 558-9911 for more information.

52. PREFERENCE FOR USE OF DOMESTIC STEEL PRODUCTS: Except when authorized by the Director of the Purchasing Division pursuant to W. Va. Code § 5A-3-56, no contractor may use or supply steel products for a State Contract Project other than those steel products made in the United States. A contractor who uses steel products in violation of this section may be subject to civil penalties pursuant to W. Va. Code § 5A-3-56. As used in this section:

- a. "State Contract Project" means any erection or construction of, or any addition to, alteration of or other improvement to any building or structure, including, but not limited to, roads or highways, or the installation of any heating or cooling or ventilating plants or other equipment, or the supply of and materials for such projects, pursuant to a contract with the State of West Virginia for which bids were solicited on or after June 6, 2001.
- b. "Steel Products" means products rolled, formed, shaped, drawn, extruded, forged, cast, fabricated or otherwise similarly processed, or processed by a combination of two or more or such operations, from steel made by the open heath, basic oxygen, electric furnace, Bessemer or other steel making process.

The Purchasing Division Director may, in writing, authorize the use of foreign steel products if:

- a. The cost for each contract item used does not exceed one tenth of one percent (.1%) of the total contract cost or two thousand five hundred dollars (\$2,500.00), whichever is greater. For the purposes of this section, the cost is the value of the steel product as delivered to the project; or
- b. The Director of the Purchasing Division determines that specified steel materials are not produced in the United States in sufficient quantity or otherwise are not reasonably available to meet contract requirements.

53. PREFERENCE FOR USE OF DOMESTIC ALUMINUM, GLASS, AND STEEL: In Accordance

with W. Va. Code § 5-19-1 et seq., and W. Va. CSR § 148-10-1 et seq., for every contract or subcontract, subject to the limitations contained herein, for the construction, reconstruction, alteration, repair, improvement or maintenance of public works or for the purchase of any item of machinery or equipment to be used at sites of public works, only domestic aluminum, glass or steel products shall be supplied unless the spending officer determines, in writing, after the receipt of offers or bids, (1) that the cost of domestic aluminum, glass or steel products is unreasonable or inconsistent with the public interest of the State of West Virginia, (2) that domestic aluminum, glass or steel products are not produced in sufficient quantities to meet the contract requirements, or (3) the available domestic aluminum, glass, or steel do not meet the contract specifications. This provision only applies to public works contracts awarded in an amount more than fifty thousand dollars (\$50,000) or public works contracts that require more than ten thousand pounds of steel products.

The cost of domestic aluminum, glass, or steel products may be unreasonable if the cost is more than twenty percent (20%) of the bid or offered price for foreign made aluminum, glass, or steel products. If the domestic aluminum, glass or steel products to be supplied or produced in a "substantial labor surplus area", as defined by the United States Department of Labor, the cost of domestic aluminum, glass, or steel products may be unreasonable if the cost is more than thirty percent (30%) of the bid or offered price for foreign made aluminum, glass, or steel products.

This preference shall be applied to an item of machinery or equipment, as indicated above, when the item is a single unit of equipment or machinery manufactured primarily of aluminum, glass or steel, is part of a public works contract and has the sole purpose or of being a permanent part of a single public works project. This provision does not apply to equipment or machinery purchased by a spending unit for use by that spending unit and not as part of a single public works project.

All bids and offers including domestic aluminum, glass or steel products that exceed bid or offer prices including foreign aluminum, glass or steel products after application of the preferences provided in this provision may be reduced to a price equal to or lower than the lowest bid or offer price for foreign aluminum, glass or steel products plus the applicable preference. If the reduced bid or offer prices are made in writing and supersede the prior bid or offer prices, all bids or offers, including the reduced bid or offer prices, will be reevaluated in accordance with this rule.

ADDITIONAL TERMS AND CONDITIONS (Construction Contracts Only)

1. **CONTRACTOR'S LICENSE:** West Virginia Code § 21-11-2 requires that all persons desiring to perform contracting work in this state be licensed. The West Virginia Contractors Licensing Board is empowered to issue the contractor's license. Applications for a contractor's license may be made by contacting the West Virginia Division of Labor.

West Virginia Code § 21-11-11 requires any prospective Vendor to include the contractor's license number on its bid. Failure to include a contractor's license number on the bid shall result in Vendor's bid being disqualified. Vendors should include a contractor's license number in the space provided below.

Contractor's Name: DANHILL CONSTRUCTION Co.

Contractor's License No. WV 001196

The apparent successful Vendor must furnish a copy of its contractor's license prior to the issuance of a purchase order/contract.

2. **DRUG-FREE WORKPLACE AFFIDAVIT:** W. Va. Code § 21-1D-5 provides that any solicitation for a public improvement contract requires each Vendor that submits a bid for the work to submit at the same time an affidavit that the Vendor has a written plan for a drug-free workplace policy. To comply with this law, Vendor must either complete the enclosed drug-free workplace affidavit and submit the same with its bid or complete a similar affidavit that fulfills all of the requirements of the applicable code. Failure to submit the signed and notarized drug-free workplace affidavit, or a similar affidavit that fully complies with the requirements of the applicable code, with the bid shall result in disqualification of Vendor's bid.
3. **DRUG FREE WORKPLACE REPORT:** Pursuant to W. Va. Code § 21-1D-7b, no less than once per year, or upon completion of the project, every contractor shall provide a certified report to the public authority which let the contract. For contracts over \$25,000, the public authority shall be the West Virginia Purchasing Division. For contracts of \$25,000 or less, the public authority shall be the agency issuing the contract. The report shall include:
- (1) Information to show that the education and training service to the requirements of West Virginia Code § 21-1D-5 was provided;
 - (2) The name of the laboratory certified by the United States Department of Health and Human Services or its successor that performs the drug tests;
 - (3) The average number of employees in connection with the construction on the public improvement;

(4) Drug test results for the following categories including the number of positive tests and the number of negative tests: (A) Pre-employment and new hires; (B) Reasonable suspicion; (C) Post-accident; and (D) Random.

Vendor should utilize the attached Certified Drug Free Workplace Report Coversheet when submitting the report required hereunder.

3. **AIA DOCUMENTS:** All construction contracts that will be completed in conjunction with architectural services procured under Chapter 5G of the West Virginia Code will be governed by the AIA A101-2007 and A201-2007 or the A107-2007 documents, as amended by the Supplementary Conditions for the State of West Virginia, in addition to the terms and conditions contained herein.
4. **SUBCONTRACTOR LIST SUBMISSION:** In accordance with W. Va. Code § 5-22-1, The apparent low bidder on a contract for the construction, alteration, decoration, painting or improvement of a new or existing building or structure valued at more than \$250,000.00 shall submit a list of all subcontractors who will perform more than \$25,000.00 of work on the project including labor and materials. This provision shall not apply to any other construction projects, such as highway, mine reclamation, water or sewer projects. Additionally, if no subcontractors who will perform more than \$25,000.00 of work are to be used to complete the project, it will be noted on the subcontractor list.
 - a. **Required Information.** The subcontractor list shall contain the following information:
 - i. Bidder's name
 - ii. Name of each subcontractor
 - iii. License numbers as required by W. Va. Code § 21-11-1 et. seq.
 - iv. Notation that no subcontractor will be used to perform more than \$25,000.00 of work, when applicable
 - b. **Submission.** The completed subcontractor list shall be provided to the Purchasing Division within one business day of the opening of bids for review. Failure to submit the subcontractor list within one business day after the deadline for submitting bids shall result in disqualification of the bid.
 - c. **Substitution of Subcontractor.** Written approval must be obtained from the State Spending Unit before any subcontractor substitution is permitted. Substitutions are not permitted unless:
 - i. The subcontractor listed in the original bid has filed for bankruptcy;
 - ii. The subcontractor in the original bid has been debarred or suspended; or
 - iii. The contractor certifies in writing that the subcontractor listed in the original bill fails, is unable, or refuses to perform his subcontract.

5. **GREEN BUILDINGS MINIMUM ENERGY STANDARDS:** In accordance with § 22-29-4, all new building construction projects of public agencies that have not entered the schematic design phase prior to July 1, 2012, or any building construction project receiving state grant funds and appropriations, including public schools, that have not entered the schematic design phase prior to July 1, 2012, shall be designed and constructed complying with the ICC International Energy Conservation Code, adopted by the State Fire Commission, and the ANSI/ASHRAE/IESNA Standard 90.1-2007: *Provided*, That if any construction project has a commitment of federal funds to pay for a portion of such project, this provision shall only apply to the extent such standards are consistent with the federal standards.

CERTIFICATION AND SIGNATURE PAGE

By signing below, I certify that I have reviewed this Solicitation in its entirety; understand the requirements, terms and conditions, and other information contained herein; that I am submitting this bid or proposal for review and consideration; that I am authorized by the bidder to execute this bid or any documents related thereto on bidder's behalf; that I am authorized to bind the bidder in a contractual relationship; and that to the best of my knowledge, the bidder has properly registered with any State agency that may require registration.

DANHILL CONSTRUCTION COMPANY
(Company)

Robert D Hill
(Authorized Signature)

ROBERT DAN HILL, PRESIDENT
(Representative Name, Title)

(304)632-1600 (304)632-1501
(Phone Number) (Fax Number)

8/29/2013
(Date)

RFQ # COR61512

ALL LABOR, MATERIALS, EQUIPMENT, AND SUPPLIES NECESSARY TO REMOVE TWO (2) EXISTING WATER STORAGE TANKS AND INSTALL ONE (1) WATER STORAGE TANK

DENMAR CORRECTIONAL CENTER

POCAHONTAS COUNTY, WV

BID FORM

Bidder's Company Name: DANHILL CONSTRUCTION COMPANY

Bidder's Address: P.O. Box 685
GAULEY BRIDGE, WV 25085

Remittance Address: _____
(If different)

Phone Number: (304) 632-1600

Fax Number: (304) 632-1501

Email Address: JUSTIN-DOZIER @ YAHOO.COM

WV Contractor's License Number: WV001196

We, the undersigned, hereby propose to furnish all materials, equipment, and labor to complete all work in a workmanlike manner, as described in the Bidding Documents.

**Contract Base Bid Option A - 300,000 Gallon Glass Coated, Bolted-Steel Water Storage Tank With Concrete Bottom and Foundation, Mixing System, Valve Vault, Fencing, Site Preparation, Access Road, 6" DIP Water Main, Connections to Existing System, Demolition and Removal of the Two (2) Existing Water Tanks, Replacement of High Service Pumps, Control Panel, Valves, Piping and Related Appurtenances for a Functional System
Complete-in-Place**

**Contract Base Bid Option B - 300,000 Gallon Welded Steel Water Storage Tank With Concrete Foundation, Mixing System, Valve Vault, Fencing, Site Preparation, Access Road, 6" DIP Water main, Connections to Existing System, Demolition and Removal of the Two (2) Existing Water Tanks, Replacement of High Service Pumps, Control Panel, Valves, Piping and Related Appurtenances for a Functional System
Complete-in-Place**

The basis of award will be issued to the lowest bidder meeting specifications on the Contract Base Bid Option A or Contract Base Bid Option B.

CONTRACT BASE BID OPTION A: NO BID THIS OPTION
(\$ _____) (Contract base bid to be written in words and numbers.)

CONTRACT BASE BID OPTION B: SIX HUNDRED FIFTY THREE THOUSAND DOLLARS
(\$ 653,000.⁰⁰) (Contract base bid to be written in words and numbers.)

Bidder understands that to the extent allowed by the West Virginia Code, the OWNER reserves the right to waive any informality or irregularity in any Bid, or Bids, and to reject any or all Bids in whole or in part; to reject a bid not accompanied by the required bid security or by other data required by the Bidding Documents; to reject any conditions of the bid by the Bidder that is in any way inconsistent with the requirements, terms, and conditions of the Bidding Documents; or to reject a bid that is in any way incomplete or irregular.

RESPECTFULLY SUBMITTED:

DATE: 8/29/2013

WV VENDOR NO.: 709053330

CONTRACTOR LICENSE NO.: WV001196

BY: Robert D. Hill

(SIGNATURE, IN INK)

TITLE: PRESIDENT

FIRM NAME: DANHILL CONSTRUCTION COMPANY

(CORPORATE SEAL
IF APPLICABLE)

ADDRESS: P.O. Box 685 GAULEY BRIDGE, WV 25085

END OF BID FORM

BID BOND

KNOW ALL MEN BY THESE PRESENTS, That we, the undersigned, Danhill Construction Company
of Gauley Bridge, West Virginia, as Principal, and Colonial Surety Co. of
Montvale, New Jersey, a corporation organized and existing under the laws of the State of NJ with its
principal office in the City of Montvale, as Surety, are held and firmly bound unto the State of West Virginia, as Obligee, in the
penal sum of 5 % Of Bid Amount (\$ 5%) for the payment of which, well and truly to be made, we jointly and
severally bind ourselves, our heirs, administrators, executors, successors and assigns.

The Condition of the above obligation is such that whereas the Principal has submitted to the Purchasing Section of the
Department of Administration a certain bid or proposal, attached hereto and made a part hereof, to enter into a contract in writing for
Remove and install water storage tanks at Denmar Correctional Center, Hillsboro, WV

NOW THEREFORE,

(a) If said bid shall be rejected, or
(b) If said bid shall be accepted and the Principal shall enter into a contract in accordance with the bid or proposal attached
hereto and shall furnish any other bonds and insurance required by the bid or proposal, and shall in all other respects perform the
agreement created by the acceptance of said bid, then this obligation shall be null and void, otherwise this obligation shall remain in full
force and effect. It is expressly understood and agreed that the liability of the Surety for any and all claims hereunder shall, in no event,
exceed the penal amount of this obligation as herein stated.

The Surety, for the value received, hereby stipulates and agrees that the obligations of said Surety and its bond shall be in no
way impaired or affected by any extension of the time within which the Obligee may accept such bid, and said Surety does hereby
waive notice of any such extension.

IN WITNESS WHEREOF, Principal and Surety have hereunto set their hands and seals, and such of them as are corporations
have caused their corporate seals to be affixed hereunto and these presents to be signed by their proper officers, this
21st day of August, 20 13.

Principal Corporate Seal

Danhill Construction Company
(Name of Principal)
By Robert D. Hill *Robert D. Hill*
(Must be President or
Vice President)
President
(Title)

Surety Corporate Seal

Colonial Surety company
(Name of Surety)
Roberta Bird *Roberta Bird*
Attorney-in-Fact

**IMPORTANT – Surety executing bonds must be licensed in West Virginia to transact surety insurance. Raised corporate seals
must be affixed, a power of attorney must be attached.**

COLONIAL SURETY COMPANY

Duncannon, Pennsylvania
Administrative Office: 50 Chestnut Ridge Road, Montvale, New Jersey 07645

GENERAL POWER OF ATTORNEY

Know all Men by These Presents, That COLONIAL SURETY COMPANY, a corporation duly organized and existing under the laws of the Commonwealth of Pennsylvania and having an administrative office in Montvale, Bergen County, NJ does by these presents make, constitute and appoint

Roberta Bird Gauley Bridge
Wayne Nunziata or Anthony J. Cimasko or Audie B. Murphy

of Montvale and the State of New Jersey its true and lawful Attorney(s)-in-Fact, with full power and authority hereby conferred in its name, place and stead, to execute, acknowledge and deliver.

Any and All Bonds

and to bind the Company thereby as fully and to the same extent as if such bonds were signed by the President, sealed with the corporate seal of the Company and duly attested by its Secretary, hereby ratifying and confirming all that the said Attorney(s)-in-Fact may do in the premises.

Be it Resolved, that the President, any Vice-President, any Secretary or any Assistant Secretary shall be and is hereby vested with full power and authority to appoint any one or more suitable persons as Attorney(s)-in-Fact to represent and act for and on behalf of the Company subject to the following provisions:

Section 1. Attorney-in-Fact. Attorney-in-Fact may be given full power and authority for and in the name of and on behalf of the Company, to execute, acknowledge and deliver, any and all bonds, recognizances, contracts, agreements of indemnity and other conditional or obligatory undertakings and any and all notices and documents canceling or terminating the Company's liability thereunder, and any such instruments so executed by any such Attorney-in-Fact shall be binding upon the Company as if signed by the President and sealed and attested by the Corporate Secretary.

In Witness Whereof, Colonial Surety Company has caused these presents to be signed by its President and its corporate seal to be hereto affixed the 27th day of April, A.D., 2011.

State of New Jersey
County of Bergen
SS.:



COLONIAL SURETY COMPANY

By Wayne Nunziata, President

On this 27th day of April, in the year 2011, before me Theresa Spinelli, a notary public, personally appeared Wayne Nunziata, personally known to me to be the person who executed the within instrument as President, on behalf of the corporation therein named and acknowledged to me that the corporation executed it.



THERESA SPINELLI
A Notary Public of New Jersey
My Commission Expires September 9, 2015

Theresa Spinelli, Notary Public

I, the undersigned Secretary of Colonial Surety Company, hereby certify that the above and foregoing is a full, true and correct copy of the Original Power of Attorney issued by said Company, and do hereby further certify that the said Power of Attorney is still in force and effect.

And I do hereby further certify that the Certification of this Power of Attorney is signed and sealed by facsimile under and by the authority of the following resolution adopted by the Board of Directors of the Colonial Surety Company at a meeting duly called and held on the 30th of January 1968, and that said resolution has not been amended or repealed:

RESOLVED, that the signature of the Secretary or any Assistant Secretary of this Corporation, and the seal of Corporation, may be affixed or printed by facsimile to any certificate to a Power of Attorney of this Corporation, and that such printed facsimile signature and seal shall be valid and binding upon this Corporation.

GIVEN under my hand and the seal of said Company, at Montvale, New Jersey this 21st day of August, 20 13.

Original printed with Blue and Black ink. For verification of the authenticity of this Power of Attorney you may call (201) 573-8788 and ask for the Power of Attorney clerk. Please refer to the above named individual(s) and details of the bond to which the power is attached.

Audie B. Murphy, Secretary

State of West Virginia
County of Fayette

AND NOW, this 21st day of August, in the calendar year of 2013, before me, a duly appointed and commissioned notary public, came the identified subscriber to the within instrument or instruments, and/or the demonstrated attorney-in-fact for said signatory and subscriber on said instrument or instruments, **Roberta Bird, attorney-in-fact of Colonial Surety Company**, an insurance company duly organized and existing under the laws of the Commonwealth of Pennsylvania and which is authorized to conduct business in this State, and that as such being authorized to do so, acknowledged that the within instrument or instruments were executed as the authorized act of his disclosed principal for the purposes therein contained, and declared to be a person executing said instrument or instruments as attorney-in-fact and with full capacity and competency, at the request of and on behalf of Colonial Surety Company therein named and acknowledged to me that the aforesaid Colonial Surety Company had authorized the execution by the aforesaid attorney-in-fact of said instrument or instruments with the intent to be legally bound as required by common and statutory law.

IN WITNESS WHEREOF, I hereunto set my hand and official seal.

A Notary Public of West Virginia
My Commission Expires on 3/28/2015

Notary Public in and for the

County of Fayette
State of West Virginia

Jessica VanMeter
NOTARY PUBLIC

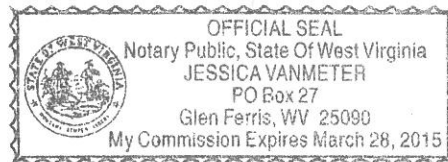

Copies of the following notice will be posted in conspicuous places available to employees or applicants for employment:

**NOTICE TO LABOR UNIONS OR OTHER ORGANIZATIONS OF WORKERS
NONDISCRIMINATION IN EMPLOYMENT**

TO: _____
(Name or union or organization or workers)

The undersigned currently holds contract(s) with (Name of Applicant) involving funds or credit of the U.S. Government or (a) subcontractor(s) with a prime contractor holding such contract(s).

You are advised that under the provisions of the above contract(s) or subcontract(s) and in accordance the Executive Order No. 11246, Section 202, dated September 24, 1965, the undersigned is obliged not to discriminate against any employee or applicant for employment because of race, color, creed, or national origin. This obligation not to discriminate in employment includes, but is not limited to, the following:

**HIRING, PLACEMENT, UPGRADING, TRANSFER OR DEMOTION,
RECRUITMENT, ADVERTISING, OR SOLICITATION FOR
EMPLOYMENT, TRAINING DURING EMPLOYMENT, RATES OF
PAY OR OTHER FORMS OF COMPENSATION, SELECTION FOR
TRAINING INCLUDING APPRENTICESHIP, LAYOFF, OR TERMINATION.**

This notice is furnished you pursuant to the provisions of the above contract(s) or subcontract(s) and Executive Order No. 11246.

Danhill Construction Construction
PO Box 685
Gauley Bridge WV 25085

(Contractor or Subcontractor)

DENMAR CORRECTIONAL COMPLEX WATER TANK REPLACEMENT
(Project Name)

CERTIFICATION OF BIDDER REGARDING EQUAL EMPLOYMENT OPPORTUNITY

INSTRUCTIONS

This certification is required pursuant to Executive Order 11246 (30 FR 12319-25). The implementing rules and regulations provide that any bidder or prospective contractor, or any of their proposed subcontractors, shall state as an initial part of the bid or negotiations of the contract whether it has participated in any previous contract or subcontract subject to the Equal Opportunity Clause; and, if so, whether it has filed all compliance reports due under applicable instructions.

Where the certificate indicates that the bidder has not filed a compliance report due under applicable instructions, such bidder shall be required to submit a compliance report within seven calendar days after bid opening. No contract shall be awarded until such report is submitted.

Robert D. Hill

CERTIFICATION BY BIDDER

NAME AND ADDRESS OF BIDDER	Danhill Construction company PO Box 685 Gowley Bridge WV 25085
-----------------------------------	--

1. Bidder had developed and maintains on file an affirmative action plan pursuant to 41 CFR Part 61-2.	<input checked="" type="radio"/> Yes	<input type="radio"/> No
---	--------------------------------------	--------------------------

2. Bidder has participated in a previous contract or subcontract subject to the Equal Opportunity Clause.	<input checked="" type="radio"/> Yes	<input type="radio"/> No
--	--------------------------------------	--------------------------

3. If #2 above is checked, compliance reports were required to be filed in connection with such contract or subcontract, and all required reports that were filed.	<input checked="" type="radio"/> Yes	<input type="radio"/> No
---	--------------------------------------	--------------------------

NAME AND TITLE OR SIGNER (Please type)	Robert D. Hill, PRESIDENT
---	---------------------------

SIGNATURE	Date: <u>8/29/2013</u>
<i>Robert D. Hill</i>	

United States Environmental Protection Agency
Washington, D.C.

**Certification Regarding
Debarment, Suspension, and Other Responsibility Matters**

The prospective participant certifies to the best of its knowledge and belief that it and its principals:

- (a) Are not presently debarred, suspended, proposed for debarment, declared ineligible, or voluntarily excluded from covered transactions by any Federal department or agency;
- (b) Have not within a three year period preceding this proposal been convicted of or had a civil judgment rendered against them for commission of fraud or a criminal offense in connection with obtaining, attempting to obtain, or performing a public (Federal, State, or local) transaction or contract under a public transaction; violation of Federal or State antitrust statutes or commission of embezzlement, theft, forgery, bribery, falsification or destruction of records, making false statements, or receiving stolen property;
- (c) Are not presently indicted for or otherwise criminally or civilly charged by a government entity (Federal, State, or local) with commission of any of the offenses enumerated in paragraph (1)(b) of this certification; and
- (d) Have not within a three-year period preceding this application/proposal had one ore more public transactions (Federal, State, or local) terminated for cause or default.

I understand that a false statement on this certification may be grounds for rejection of this proposal or termination of the award. In addition, under 18 USC Sec. 1001, a false statement may result in a fine of up to \$10,000 or imprisonment for up to 5 years, or both.

ROBERT DAN HILL, PRESIDENT

Typed Name & Title of Authorized Representative

Robert D. Hill

Signature of Authorized Representative

8/29/2013

Date

I am unable to certify to the above statements. My explanation is attached.

Davis-Bacon Certification

I hereby certify that the project listed below complies, to the best of my knowledge, with 29CFR5.5(a)(1) and all other applicable provisions of the Davis-Bacon Act.

29CFR5.5(a)(1): Minimum wages. (i) All laborers and mechanics employed or working upon the site of the work (or under the United States Housing Act of 1937 or under the Housing Act of 1949 in the construction or development of the project), will be paid unconditionally and not less often than once a week, and without subsequent deduction or rebate on any account (except such payroll deductions as are permitted by regulations issued by the Secretary of Labor under the Copeland Act (29CFR part 3)), the full amount of wages and bona fide fringe benefits (or cash equivalents thereof) due at time of payment computed at rates not less than those contained in the wage determination of the Secretary of Labor which is attached hereto and made a part hereof, regardless of any contractual relationship which may be alleged to exist between the contractor and such laborers and mechanics.

Contributions made or costs reasonably anticipated for bona fide fringe benefits under section 1(b)(2) of the Davis-Bacon Act on behalf of laborers or mechanics are considered wages paid to such laborers or mechanics, subject to the provisions of paragraph (a)(1)(iv) of this section; also, regular contributions made or costs incurred for more than a weekly period (but not less often than quarterly) under plans, funds, or programs which cover the particular weekly period, are deemed to be constructively made or incurred during such weekly period. Such laborers and mechanics shall be paid the appropriate wage rate and fringe benefits on the wage determination for the classification of work actually performed, without regard to skill, except as provided in Sec. 5.5(a)(4). Laborers or mechanics performing work in more than one classification may be compensated at the rate specified for each classification for the time actually worked therein: Provided, That the employer's payroll records accurately set forth the time spent in each classification in which work is performed. The wage determination (including any additional classification and wage rates conformed under paragraph (a)(1)(ii) of this section) and the Davis-Bacon poster (WH-1321) shall be posted at all times by the contractor and its subcontractors at the site of the work in a prominent and accessible place where it can be easily seen by the workers.

DENMAR CORRECTIONAL COMPLEX WATER TANK REPLACEMENT
Project Name

Payrolls received from _____ to _____

Robert D. Hill
Signature of Authorized Official

8/29/2013
Date

ROBERT DAN HILL, PRESIDENT
Print Name and Title of Authorized Official



State of West Virginia
DRUG FREE WORKPLACE CONFORMANCE AFFIDAVIT
West Virginia Code §21-1D-5

STATE OF West Virginia

COUNTY OF Fayette, TO-WIT:

I, Robert D. Hill, after being first duly sworn, depose and state as follows:

- 1. I am an employee of Danhill Construction Company; and,
2. I do hereby attest that Danhill Construction Company

maintains a valid written drug free workplace policy and that such policy is in compliance with West Virginia Code §21-1D-5.

The above statements are sworn to under the penalty of perjury.

Danhill Construction Company
(Company Name)

By: Robert D. Hill

Title: President

Date: August 29, 2013

Taken, subscribed and sworn to before me this 29th day of August

By Commission expires Nov. 1, 2021

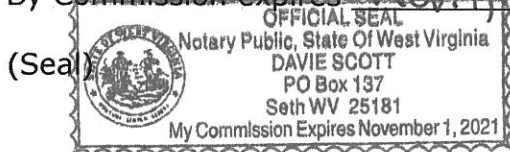

Davie Scott
(Notary Public)

THIS AFFIDAVIT MUST BE SUBMITTED WITH THE BID IN ORDER TO COMPLY WITH WV CODE PROVISIONS. FAILURE TO INCLUDE THE AFFIDAVIT WITH THE BID SHALL RESULT IN DISQUALIFICATION OF THE BID.

CONTRACTOR LICENSE

Authorized by the

West Virginia Contractor Licensing Board

Number: WV001196

Classification:

ELECTRICAL
GENERAL BUILDING
HEATING, VENTILATING & COOLING
MULTIFAMILY
PIPING
PLUMBING
RESIDENTIAL

DANHILL CONSTRUCTION COMPANY
DBA DANHILL CONSTRUCTION COMPANY
PO BOX 685
GAULEY BRIDGE, WV 25085-0685

Date Issued

AUGUST 06, 2013

Expiration Date

AUGUST 06, 2014

Robert D. Hill
Authorized Company Signature

Michael A. Carl
Chair, West Virginia Contractor
Licensing Board

**WEST VIRGINIA
CONTRACTOR
LICENSING
BOARD**

This license, or a copy thereof, must be posted in a conspicuous place at every construction site where work is being performed. This license number must appear in all advertisements, on all bid submissions and on all fully executed and binding contracts. This license cannot be assigned or transferred by licensee. Issued under provisions of West Virginia Code, Chapter 21, Article 11.



State of West Virginia
 Department of Administration
 Purchasing Division
 2019 Washington Street East
 Post Office Box 50130
 Charleston, WV 25305-0130

Solicitation

NUMBER
COR61512

PAGE
1

ADDRESS CORRESPONDENCE TO ATTENTION OF:
TARA LYLE
304-558-2544

RFQ COPY
 TYPE NAME/ADDRESS HERE

VENDOR FOR

Danhill Construction Company
 PO Box 685
 Gauley Bridge, WV 25085

SHIP TO

DENMAR CORRECTIONAL CENTER
 HC-64, BOX 125
 DENMAR ROAD
 HILLSBORO, WV
 24946

DATE PRINTED
08/06/2013

BID OPENING DATE: 08/22/2013 BID OPENING TIME 1:30PM

LINE	QUANTITY	UOP	CAT. NO.	ITEM NUMBER	UNIT PRICE	AMOUNT
				ADDENDUM NO. 1 SEE ATTACHED PAGES. END OF ADDENDUM NO. 1		
0001	1	JB		968-42 REMOVAL/INSTALL OF WATER STORAGE TANKS		
***** THIS IS THE END OF RFQ COR61512 ***** TOTAL:						

SIGNATURE	<i>Robert D. Hill</i>	TELEPHONE	(304)632-1600	DATE	8/29/2013
TITLE	PRESIDENT	FEIN	55-0648251	ADDRESS CHANGES TO BE NOTED ABOVE	

WHEN RESPONDING TO SOLICITATION, INSERT NAME AND ADDRESS IN SPACE ABOVE LABELED 'VENDOR'

SOLICITATION NUMBER: COR61512
Addendum Number: 1

The purpose of this addendum is to modify the solicitation identified as COR61512 ("Solicitation") to reflect the change(s) identified and described below.

Applicable Addendum Category:

- Modify bid opening date and time
- Modify specifications of product or service being sought
- Attachment of vendor questions and responses
- Attachment of pre-bid sign-in sheet
- Correction of error
- Other

Description of Modification to Solicitation:

1. Pre-bid sign in sheets attached – Exhibit 1.
2. To move the question deadline from 08/07/2013 at 5:00 pm to 8/13/2013 at 5:00 pm.
3. To move the bid opening date from 08/15/2013 to 08/22/2013 at 1:30 pm.

Additional Documentation: Documentation related to this Addendum (if any) has been included herewith as Attachment A and is specifically incorporated herein by reference.

Terms and Conditions:

1. All provisions of the Solicitation and other addenda not modified herein shall remain in full force and effect.
2. Vendor should acknowledge receipt of all addenda issued for this Solicitation by completing an Addendum Acknowledgment, a copy of which is included herewith. Failure to acknowledge addenda may result in bid disqualification. The addendum acknowledgement should be submitted with the bid to expedite document processing.

COR 61512 - Pre-Bid Sign-In Sheet **SIGN IN SHEET**

Request for Proposal No.

PLEASE PRINT

Page 1 of 1
Date: 8/6/2013

* PLEASE BE SURE TO PRINT LEGIBLY - IF POSSIBLE, LEAVE A BUSINESS CARD

FIRM & REPRESENTATIVE NAME	MAILING ADDRESS	TELEPHONE & FAX NUMBERS
Company: <u>Johnson Controls</u> Rep: <u>Bill Fazenbaker</u> Email Address: <u>Guy, W. Fazenbaker, Jr - EME@JCI.COM</u>	<u>940 E High St</u> <u>OAKLAND MD 21550</u>	PHONE <u>240-321-1796</u> TOLL FREE FAX
Company: <u>DANHILL CONSTRUCTION COMPANY</u> Rep: <u>JUSTIN DOZIER</u> Email Address: <u>JUSTIN-DOZIER@yahoo.com</u>	<u>P.O. Box 685</u> <u>GRAULEY BRIDGE, WV 25085</u>	PHONE <u>304-632-1600 Ext. 7</u> TOLL FREE FAX <u>304-632-1501</u>
Company: <u>Mid Atlantic Storage Systems, Inc</u> Rep: <u>Lorry Morris</u> Email Address: <u>Lorry@midatlanticstorage.com</u>	<u>1551 Robinson Rd SE</u> <u>Washington CH OH 43160</u>	PHONE <u>740 335 2019</u> TOLL FREE FAX <u>740 335 0584</u>
Company: _____ Rep: _____ Email Address: _____	_____ _____	PHONE _____ TOLL FREE FAX
Company: _____ Rep: _____ Email Address: _____	_____ _____	PHONE _____ TOLL FREE FAX

000003

ADDENDUM ACKNOWLEDGEMENT FORM
SOLICITATION NO.: COR61512

Instructions: Please acknowledge receipt of all addenda issued with this solicitation by completing this addendum acknowledgment form. Check the box next to each addendum received and sign below. Failure to acknowledge addenda may result in bid disqualification.

Acknowledgment: I hereby acknowledge receipt of the following addenda and have made the necessary revisions to my proposal, plans and/or specification, etc.

Addendum Numbers Received:

(Check the box next to each addendum received)

<input checked="" type="checkbox"/> Addendum No. 1	<input type="checkbox"/> Addendum No. 6
<input checked="" type="checkbox"/> Addendum No. 2	<input type="checkbox"/> Addendum No. 7
<input checked="" type="checkbox"/> Addendum No. 3	<input type="checkbox"/> Addendum No. 8
<input checked="" type="checkbox"/> Addendum No. 4	<input type="checkbox"/> Addendum No. 9
<input type="checkbox"/> Addendum No. 5	<input type="checkbox"/> Addendum No. 10

I understand that failure to confirm the receipt of addenda may be cause for rejection of this bid. I further understand that that any verbal representation made or assumed to be made during any oral discussion held between Vendor's representatives and any state personnel is not binding. Only the information issued in writing and added to the specifications by an official addendum is binding.

DANHILL CONSTRUCTION COMPANY
Company

Robert D. Hill

Authorized Signature

8/29/2013

Date

NOTE: This addendum acknowledgment should be submitted with the bid to expedite document processing.



State of West Virginia
 Department of Administration
 Purchasing Division
 2019 Washington Street East
 Post Office Box 50130
 Charleston, WV 25305-0130

Solicitation

NUMBER
COR61512

PAGE
1

ADDRESS CORRESPONDENCE TO ATTENTION OF:
TARA LYLE
304-558-2544

RFQ COPY

TYPE NAME/ADDRESS HERE

V
E
N
D
O
R

Danhill Construction Company
 PO Box 685
 Gauley Bridge, WV 25085

S
H
I
P
T
O

DENMAR CORRECTIONAL CENTER
 HC-64, BOX 125
 DENMAR ROAD
 HILLSBORO, WV
 24946

DATE PRINTED
08/14/2013

BID OPENING DATE: 08/22/2013

BID OPENING TIME 1:30PM

LINE	QUANTITY	UOP	CAT NO	ITEM NUMBER	UNIT PRICE	AMOUNT
				ADDENDUM NO. 2		
				SEE ATTACHED PAGES.		
				END OF ADDENDUM NO. 2		
0001	1	JB		968-42		
				REMOVAL/INSTALL OF WATER STORAGE TANKS		
***** THIS IS THE END OF RFQ COR61512 ***** TOTAL:						

SIGNATURE <i>Robert D. Hill</i>	TELEPHONE (304)632-1600	DATE 8/29/2013
TITLE PRESIDENT	FEIN 55-0648251	ADDRESS CHANGES TO BE NOTED ABOVE

WHEN RESPONDING TO SOLICITATION, INSERT NAME AND ADDRESS IN SPACE ABOVE LABELED 'VENDOR'

SOLICITATION NUMBER: COR61512
Addendum Number: 2

The purpose of this addendum is to modify the solicitation identified as COR61512 ("Solicitation") to reflect the change(s) identified and described below.

Applicable Addendum Category:

- Modify bid opening date and time
- Modify specifications of product or service being sought
- Attachment of vendor questions and responses
- Attachment of pre-bid sign-in sheet
- Correction of error
- Other

Description of Modification to Solicitation:

1. Vendor questions and responses attached.
2. Drawing entitled "Liquid Level Indicator Details" attached.
3. The bid opening remains 08/22/2013 at 1:30 pm.

Additional Documentation: Documentation related to this Addendum (if any) has been included herewith as Attachment A and is specifically incorporated herein by reference.

Terms and Conditions:

1. All provisions of the Solicitation and other addenda not modified herein shall remain in full force and effect.
2. Vendor should acknowledge receipt of all addenda issued for this Solicitation by completing an Addendum Acknowledgment, a copy of which is included herewith. Failure to acknowledge addenda may result in bid disqualification. The addendum acknowledgement should be submitted with the bid to expedite document processing.

ATTACHMENT A

Questions:

Q1: The existing tanks will need to be cut into pieces in order to move to staging area, is there a certain dimension that these pieces need to be cut?

A1: Contractor to cut the metal pieces of the existing tank to the discretion of the contractor. Please see Clarification C2.

Q2: Are there B&O, City, County, etc. taxes associated with this project?

A2: It will be up to the contractor to contact the necessary representative with the city, county, etc.

Q3: Are there any liquidated damages, if so, how much per day?

A3: Yes, the liquidated damages amount per day is \$750.00.

Q4: Are materials incorporated into the project subject to WV sales tax?

A4: Please refer to Section 23 – Taxes of the General Terms and Conditions in the RFQ.

Q5: Drawing 1 shows a 'spoil storage area'. Will demolition concrete be allowed in the 'spoil storage area'?

A5: Yes.

Q6: If demolition concrete isn't allowed in the 'spoil storage area', does the State have a disposal location and how far from the tank site is the disposal location?

A6: Please see Question 5.

Clarifications:

- C1: The liquid level indicator on the new water storage tank has been added. Please see Exhibit #1 for the drawing details.
- C2: It is the responsibility of the contractor to dispose of all the items from the existing metal storage tanks, foundations (other than concrete), pipes, and accessories at no cost of the owner.
- C3: On water storage tank #1, the facility will drain the tank below the areas where the wooden pegs are driven in the metal tank. Contractor must provide and weld metal plates large enough to cover the existing holes in the metal tank where the wooden pegs are located. This is required to be done before the winter season, this year.

The bid opening remains August 22, 2013 at 1:30 pm.

No additional questions will be accepted on this RFQ.

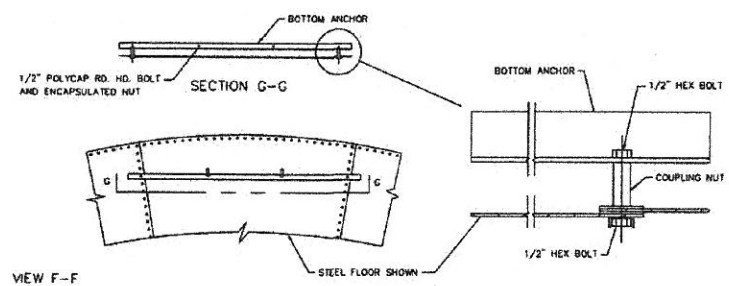
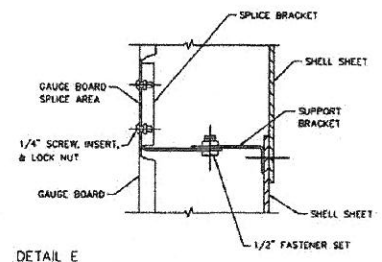
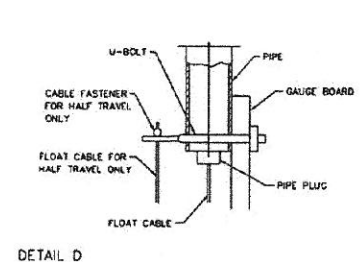
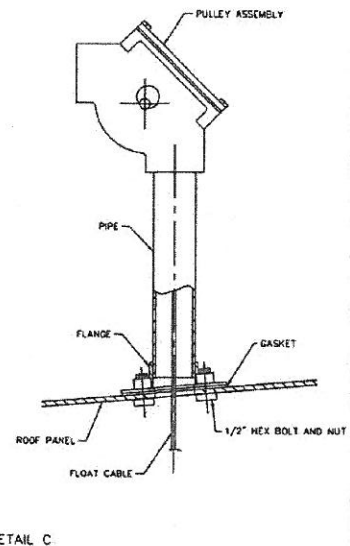
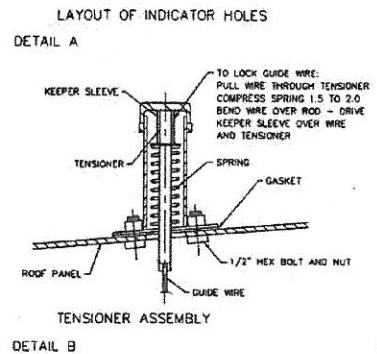
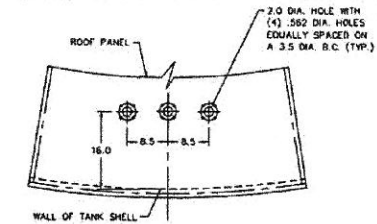
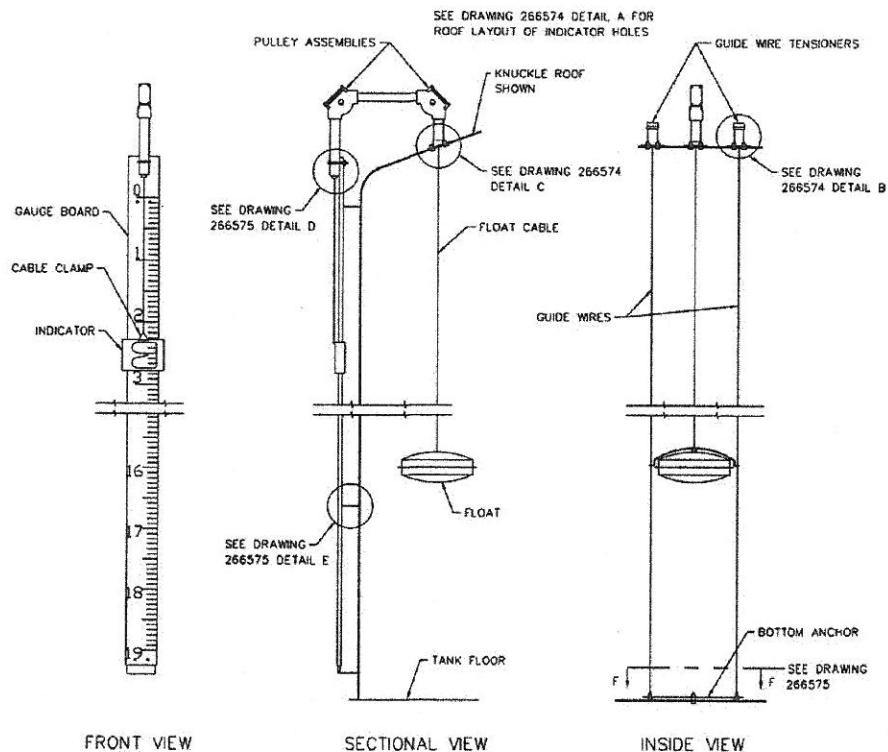

DENMAR CORRECTIONAL FACILITY
POCAHONTAS COUNTY, WEST VIRGINIA

LIQUID LEVEL INDICATOR DETAILS

NOT TO SCALE DATE: AUG. 2013

S & S ENGINEERS, INC.
501 EAGLE MTN. ROAD
CHARLESTON, WEST VIRGINIA



ADDENDUM ACKNOWLEDGEMENT FORM
SOLICITATION NO.: COR61512

Instructions: Please acknowledge receipt of all addenda issued with this solicitation by completing this addendum acknowledgment form. Check the box next to each addendum received and sign below. Failure to acknowledge addenda may result in bid disqualification.

Acknowledgment: I hereby acknowledge receipt of the following addenda and have made the necessary revisions to my proposal, plans and/or specification, etc.

Addendum Numbers Received:

(Check the box next to each addendum received)

- | | |
|--|--|
| <input checked="" type="checkbox"/> Addendum No. 1 | <input type="checkbox"/> Addendum No. 6 |
| <input checked="" type="checkbox"/> Addendum No. 2 | <input type="checkbox"/> Addendum No. 7 |
| <input checked="" type="checkbox"/> Addendum No. 3 | <input type="checkbox"/> Addendum No. 8 |
| <input checked="" type="checkbox"/> Addendum No. 4 | <input type="checkbox"/> Addendum No. 9 |
| <input type="checkbox"/> Addendum No. 5 | <input type="checkbox"/> Addendum No. 10 |

I understand that failure to confirm the receipt of addenda may be cause for rejection of this bid. I further understand that that any verbal representation made or assumed to be made during any oral discussion held between Vendor's representatives and any state personnel is not binding. Only the information issued in writing and added to the specifications by an official addendum is binding.

DANHILL CONSTRUCTION COMPANY
Company

Robert D. Hill

Authorized Signature

8/29/2013

Date

NOTE: This addendum acknowledgement should be submitted with the bid to expedite document processing.



State of West Virginia
 Department of Administration
 Purchasing Division
 2019 Washington Street East
 Post Office Box 50130
 Charleston, WV 25305-0130

Solicitation

NUMBER
COR61512

PAGE
1

ADDRESS CORRESPONDENCE TO ATTENTION OF:
TARA LYLE
304-558-2544

*709053330 304-632-1558
 DANHILL CONSTRUCTION COMPANY
 PO BOX 685

VENDOR

GAULEY BRIDGE WV 25085

DENMAR CORRECTIONAL CENTER

SHIP TO

HC-64, BOX 125
 DENMAR ROAD
 HILLSBORO, WV
 24946

DATE PRINTED
08/20/2013

BID OPENING DATE: 08/22/2013

BID OPENING TIME 1:30PM

LINE	QUANTITY	UOP	CAT NO.	ITEM NUMBER	UNIT PRICE	AMOUNT
				ADDENDUM NO. 3		
				SEE ATTACHED PAGES.		
				END OF ADDENDUM NO. 3		
0001		JB		968-42		
	1			REMOVAL/INSTALL OF WATER STORAGE TANKS		
				***** THIS IS THE END OF RFQ COR61512 ***** TOTAL:		

SIGNATURE	<i>Robert D. Hill</i>	TELEPHONE	(304)632-1600	DATE	8/29/2013
TITLE	PRESIDENT	FEIN	55-0648251	ADDRESS CHANGES TO BE NOTED ABOVE	

WHEN RESPONDING TO SOLICITATION, INSERT NAME AND ADDRESS IN SPACE ABOVE LABELED 'VENDOR'

SOLICITATION NUMBER: COR61512
Addendum Number: 3

The purpose of this addendum is to modify the solicitation identified as COR61512 ("Solicitation") to reflect the change(s) identified and described below.

Applicable Addendum Category:

- Modify bid opening date and time
- Modify specifications of product or service being sought
- Attachment of vendor questions and responses
- Attachment of pre-bid sign-in sheet
- Correction of error
- Other

Description of Modification to Solicitation:

1. To change the number of days in which to complete the project in Section 3 – Contract Term; Renewal; Extension, page 7 of the RFQ, from 60 days to 270 days.
2. The bid opening remains 08/22/2013 at 1:30 pm.

Additional Documentation: Documentation related to this Addendum (if any) has been included herewith as Attachment A and is specifically incorporated herein by reference.

Terms and Conditions:

1. All provisions of the Solicitation and other addenda not modified herein shall remain in full force and effect.
2. Vendor should acknowledge receipt of all addenda issued for this Solicitation by completing an Addendum Acknowledgment, a copy of which is included herewith. Failure to acknowledge addenda may result in bid disqualification. The addendum acknowledgement should be submitted with the bid to expedite document processing.

ADDENDUM ACKNOWLEDGEMENT FORM
SOLICITATION NO.: COR61512

Instructions: Please acknowledge receipt of all addenda issued with this solicitation by completing this addendum acknowledgment form. Check the box next to each addendum received and sign below. Failure to acknowledge addenda may result in bid disqualification.

Acknowledgment: I hereby acknowledge receipt of the following addenda and have made the necessary revisions to my proposal, plans and/or specification, etc.

Addendum Numbers Received:

(Check the box next to each addendum received)

- | | |
|--|--|
| <input checked="" type="checkbox"/> Addendum No. 1 | <input type="checkbox"/> Addendum No. 6 |
| <input checked="" type="checkbox"/> Addendum No. 2 | <input type="checkbox"/> Addendum No. 7 |
| <input checked="" type="checkbox"/> Addendum No. 3 | <input type="checkbox"/> Addendum No. 8 |
| <input checked="" type="checkbox"/> Addendum No. 4 | <input type="checkbox"/> Addendum No. 9 |
| <input type="checkbox"/> Addendum No. 5 | <input type="checkbox"/> Addendum No. 10 |

I understand that failure to confirm the receipt of addenda may be cause for rejection of this bid. I further understand that that any verbal representation made or assumed to be made during any oral discussion held between Vendor's representatives and any state personnel is not binding. Only the information issued in writing and added to the specifications by an official addendum is binding.

DANHILL CONSTRUCTION COMPANY
Company

Robert D. Hill
Authorized Signature

8/29/2013
Date

NOTE: This addendum acknowledgment should be submitted with the bid to expedite document processing.



State of West Virginia
 Department of Administration
 Purchasing Division
 2019 Washington Street East
 Post Office Box 50130
 Charleston, WV 25305-0130

WV PURCHASING AGENCY SECTION Fax 304-558-4115

Aug 23 2013 02:14pm P002/004

COR61512

1

ADDRESS CORRESPONDENCE TO ATTENTION OF:
 TARA LYLE
 304-558-2544

RFQ COPY

TYPE NAME/ADDRESS HERE

V
E
N
D
O
R

S
H
I
P
T
O

DENMAR CORRECTIONAL CENTER

HC-64, BOX 125
 DENMAR ROAD
 HILLSBORO, WV
 24946

DATE PRINTED
 08/23/2013

BID OPENING DATE: 08/29/2013

BID OPENING TIME 1:30PM

LINE	QUANTITY	UOP	CAT NO	ITEM NUMBER	UNIT PRICE	AMOUNT
ADDENDUM NO. 4						
THE BID OPENING FOR COR61512 SCHEDULED FOR AUGUST 22, 2013, 1:30 PM, HAS BEEN EXTENDED TO AUGUST 29, 2013. THE BID OPENING TIME AND LOCATION REMAINS THE SAME.						
END OF ADDENDUM NO. 4						
0001	1	JB		968-42		
REMOVAL/INSTALL OF WATER STORAGE TANKS						
***** THIS IS THE END OF RFQ COR61512 ***** TOTAL:						

SIGNATURE Robert D. Hill TELEPHONE (304)632-1600 DATE 8-29-2013
 TITLE PRESIDENT FEIN 55-0648251 ADDRESS CHANGES TO BE NOTED ABOVE

WHEN RESPONDING TO SOLICITATION, INSERT NAME AND ADDRESS IN SPACE ABOVE LABELED 'VENDOR'

000002

State of West Virginia
West Virginia Purchasing Division
COR61512 Addendum No. 4

The bid opening for COR61512 scheduled for August 22, 2013, 1:30 PM, has been extended to August 29, 2013. The bid-opening time and location remains the same.

000003

ADDENDUM ACKNOWLEDGEMENT FORM
SOLICITATION NO.: COR61512

Instructions: Please acknowledge receipt of all addenda issued with this solicitation by completing this addendum acknowledgment form. Check the box next to each addendum received and sign below. Failure to acknowledge addenda may result in bid disqualification.

Acknowledgment: I hereby acknowledge receipt of the following addenda and have made the necessary revisions to my proposal, plans and/or specification, etc.

Addendum Numbers Received:

(Check the box next to each addendum received)

- | | |
|--|--|
| <input checked="" type="checkbox"/> Addendum No. 1 | <input type="checkbox"/> Addendum No. 6 |
| <input checked="" type="checkbox"/> Addendum No. 2 | <input type="checkbox"/> Addendum No. 7 |
| <input checked="" type="checkbox"/> Addendum No. 3 | <input type="checkbox"/> Addendum No. 8 |
| <input checked="" type="checkbox"/> Addendum No. 4 | <input type="checkbox"/> Addendum No. 9 |
| <input type="checkbox"/> Addendum No. 5 | <input type="checkbox"/> Addendum No. 10 |

I understand that failure to confirm the receipt of addenda may be cause for rejection of this bid. I further understand that that any verbal representation made or assumed to be made during any oral discussion held between Vendor's representatives and any state personnel is not binding. Only the information issued in writing and added to the specifications by an official addendum is binding.

DANHILL CONSTRUCTION COMPANY
Company

Robert D. Hill
Authorized Signature

8/29/2013
Date

NOTE: This addendum acknowledgment should be submitted with the bid to expedite document processing.

RFQ No. COR61512

STATE OF WEST VIRGINIA
Purchasing Division
PURCHASING AFFIDAVIT

MANDATE: Under W. Va. Code §5A-3-10a, no contract or renewal of any contract may be awarded by the state or any of its political subdivisions to any vendor or prospective vendor when the vendor or prospective vendor or a related party to the vendor or prospective vendor is a debtor and: (1) the debt owed is an amount greater than one thousand dollars in the aggregate; or (2) the debtor is in employer default.

EXCEPTION: The prohibition listed above does not apply where a vendor has contested any tax administered pursuant to chapter eleven of the W. Va. Code, workers' compensation premium, permit fee or environmental fee or assessment and the matter has not become final or where the vendor has entered into a payment plan or agreement and the vendor is not in default of any of the provisions of such plan or agreement.

DEFINITIONS:

"Debt" means any assessment, premium, penalty, fine, tax or other amount of money owed to the state or any of its political subdivisions because of a judgment, fine, permit violation, license assessment, defaulted workers' compensation premium, penalty or other assessment presently delinquent or due and required to be paid to the state or any of its political subdivisions, including any interest or additional penalties accrued thereon.

"Employer default" means having an outstanding balance or liability to the old fund or to the uninsured employers' fund or being in policy default, as defined in W. Va. Code § 23-2c-2, failure to maintain mandatory workers' compensation coverage, or failure to fully meet its obligations as a workers' compensation self-insured employer. An employer is not in employer default if it has entered into a repayment agreement with the Insurance Commissioner and remains in compliance with the obligations under the repayment agreement.

"Related party" means a party, whether an individual, corporation, partnership, association, limited liability company or any other form or business association or other entity whatsoever, related to any vendor by blood, marriage, ownership or contract through which the party has a relationship of ownership or other interest with the vendor so that the party will actually or by effect receive or control a portion of the benefit, profit or other consideration from performance of a vendor contract with the party receiving an amount that meets or exceeds five percent of the total contract amount.

AFFIRMATION: By signing this form, the vendor's authorized signer affirms and acknowledges under penalty of law for false swearing (W. Va. Code §61-5-3) that neither vendor nor any related party owe a debt as defined above and that neither vendor nor any related party are in employer default as defined above, unless the debt or employer default is permitted under the exception above.

WITNESS THE FOLLOWING SIGNATURE:

Vendor's Name: DANHILL CONSTRUCTION COMPANY

Authorized Signature: Robert D. Hill Date: 8/29/2013

State of West Virginia

County of Fayette, to-wit:

Taken, subscribed, and sworn to before me this 29th day of August, 2013.

My Commission expires Nov. 1, 2021.

AFFIX SEAL HERE

NOTARY PUBLIC Janie Scott

Purchasing Affidavit (Revised 07/01/2012)

