



State of West Virginia
 Department of Administration
 Purchasing Division
 2019 Washington Street East
 Post Office Box 50130
 Charleston, WV 25305-0130

Solicitation

NUMBER
8514C2023

PAGE
1

ADDRESS CORRESPONDENCE TO ATTENTION OF:
CRYSTAL RINK 304-558-2402

*709032901 630-377-9100

VENDOR

WORK AREA PROTECTION CORP
 2500 PRODUCTION DR
 SAINT CHARLES IL 60174-3350

SHIP TO

DIVISION OF HIGHWAYS
 TRAFFIC ENGINEERING DIVISION
 VARIOUS LOCALES AS INDICATED
 BY ORDER

DATE PRINTED
04/08/2014

BID OPENING DATE: 05/07/2014 BID OPENING TIME 1:30PM

LINE	QUANTITY	UOP	CAT NO	ITEM NUMBER	UNIT PRICE	AMOUNT
0001		EA		550-78		
				CONES, TRAFFIC (PORTABLE)		
				REQUEST FOR QUOTATION (OPEN-END CONTRACT)		
				THE WEST VIRGINIA STATE PURCHASING DIVISION FOR THE AGENCY, THE WEST VIRGINIA DIVISION OF HIGHWAYS, IS SOLICITING BIDS TO ESTABLISH AN OPEN-END CONTRACT FOR FLEXIBLE PLASTIC CHANNELIZER CONES PER THE ATTACHED SPECIFICATIONS.		
0002	1	EA		550-78		
				REPLACEMENT FLEXIBLE PLASTIC CHANNELIZER CONE		
0003	1	EA		550-78		
				REPLACEMENT FLEXIBLE PLASTIC CHANNELIZER CONE RUBBER		

05/05/14 10:16:48AM
 West Virginia Purchasing Division

SIGNATURE 	TELEPHONE 800-327-4417	DATE 5/1/14
TITLE Vice President	FEIN 52-1488457	ADDRESS CHANGES TO BE NOTED ABOVE

WHEN RESPONDING TO SOLICITATION, INSERT NAME AND ADDRESS IN SPACE ABOVE LABELED 'VENDOR'

CERTIFICATION AND SIGNATURE PAGE

By signing below, I certify that I have reviewed this Solicitation in its entirety; understand the requirements, terms and conditions, and other information contained herein; that I am submitting this bid or proposal for review and consideration; that I am authorized by the bidder to execute this bid or any documents related thereto on bidder's behalf; that I am authorized to bind the bidder in a contractual relationship; and that to the best of my knowledge, the bidder has properly registered with any State agency that may require registration.

Work Area Protection Corp.

(Company)

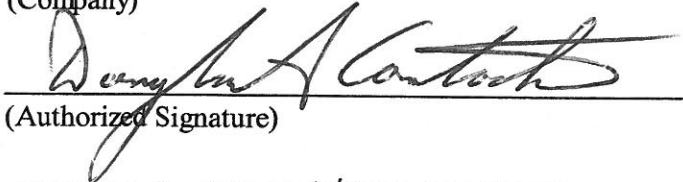

(Authorized Signature)

Douglas S. Comstock/Vice President

(Representative Name, Title)

800-327-4417

630-377-9270

(Phone Number)

(Fax Number)

5/1/14

(Date)

ADDENDUM ACKNOWLEDGEMENT FORM
SOLICITATION NO.: 8514C023

Instructions: Please acknowledge receipt of all addenda issued with this solicitation by completing this addendum acknowledgment form. Check the box next to each addendum received and sign below. Failure to acknowledge addenda may result in bid disqualification.

Acknowledgment: I hereby acknowledge receipt of the following addenda and have made the necessary revisions to my proposal, plans and/or specification, etc.

Addendum Numbers Received:

(Check the box next to each addendum received)

- | | |
|---|--|
| <input type="checkbox"/> Addendum No. 1 | <input type="checkbox"/> Addendum No. 6 |
| <input type="checkbox"/> Addendum No. 2 | <input type="checkbox"/> Addendum No. 7 |
| <input type="checkbox"/> Addendum No. 3 | <input type="checkbox"/> Addendum No. 8 |
| <input type="checkbox"/> Addendum No. 4 | <input type="checkbox"/> Addendum No. 9 |
| <input type="checkbox"/> Addendum No. 5 | <input type="checkbox"/> Addendum No. 10 |

I understand that failure to confirm the receipt of addenda may be cause for rejection of this bid. I further understand that any verbal representation made or assumed to be made during any oral discussion held between Vendor's representatives and any state personnel is not binding. Only the information issued in writing and added to the specifications by an official addendum is binding.

Work Area Protection Corp.

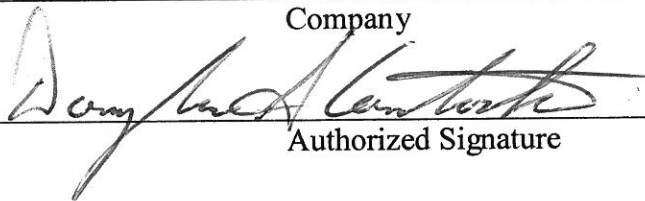
 Company

 Authorized Signature
 5/1/14

 Date

NOTE: This addendum acknowledgement should be submitted with the bid to expedite document processing.

-
- (b) Obtaining the items ordered from a third party, and/or
 - (c) Subjecting the Vendor to a daily (per Calendar Day) penalty at the purchasing organizations discretion for each Calendar Day beyond twenty-five (25) Working Days ARO until the order is received in full. This penalty shall be assessed by subtracting the penalty from the original total value of the Release Order. The penalty shall be calculated based on the Table attached as Exhibit G and shown at the following address:
<http://www.transportation.wv.gov/highways/contractadmin/specifications/Pages/LiquidDatedDamages.aspx>

The original total amount of the Release Order shall be substituted for the “Original Contract Amount” when using this Table.

Any Agency seeking to obtain items from a third party under this provision must first obtain approval of the Purchasing Division.

- 6.4 Delivery Payment/Risk of Loss:** Standard order delivery shall be F.O.B. destination to the Agency’s location. Vendor shall include the cost of standard order delivery charges in its bid pricing/discount and is not permitted to charge the Agency separately for such delivery. The Agency will pay delivery charges on all emergency orders provided that Vendor invoices those delivery costs as a separate charge with the original freight bill attached to the invoice.
- 6.5 Return of Unacceptable Items:** If the Agency deems the Contract Items to be unacceptable, the Contract Items shall be returned to Vendor at Vendor’s expense and with no restocking charge. Vendor shall either make arrangements for the return within five (5) days of being notified that items are unacceptable, or permit the Agency to arrange for the return and reimburse Agency for delivery expenses. If the original packaging cannot be utilized for the return, Vendor will supply the Agency with appropriate return packaging upon request. All returns of unacceptable items shall be F.O.B. the Agency’s location. The returned product shall either be replaced, or the Agency shall receive a full credit or refund for the purchase price, at the Agency’s discretion.

6.6 Return Due to Agency Error: Items ordered in error by the Agency will be returned for credit within 30 days of receipt, F.O.B. Vendor's location. Vendor shall not charge a restocking fee if returned products are in a resalable condition. Items shall be deemed to be in a resalable condition if they are unused and in the original packaging. Any restocking fee for items not in a resalable condition shall be the lower of the Vendor's customary restocking fee or 5% of the total invoiced value of the returned items.

7. MISCELLANEOUS:

7.1 No Substitutions: Vendor shall supply only Contract Items submitted in response to the RFQ unless a contract modification is approved in accordance with the provisions contained in this Contract.

7.2 Vendor Supply: Vendor must carry sufficient inventory of the Contract Items being offered to fulfill its obligations under this Contract. By signing its bid, Vendor certifies that it can supply the Contract Items contained in its bid response.

7.3 Reports: Vendor shall provide quarterly reports and annual summaries to the Agency showing the Agency's items purchased, quantities of items purchased, and total dollar value of the items purchased. Vendor shall also provide reports, upon request, showing the items purchased during the term of this Contract, the quantity purchased for each of those items, and the total value of purchases for each of those items. Failure to supply such reports may be grounds for cancellation of this Contract.

7.4 Contract Manager: During its performance of this Contract, Vendor must designate and maintain a primary contract manager responsible for overseeing Vendor's responsibilities under this Contract. The Contract manager must be available during normal business hours to address any customer service or other issues related to this Contract. Vendor should list its Contract manager and his or her contact information below.

Contract Manager: Charles Frick
Telephone Number: 770-527-7460
Fax Number: 630-327-4417
Email Address: workarea@workareaprotection.com

BID SCHEDULE

Quantities listed in this RFQ are approximations only. It is understood and agreed that the contract shall cover the quantities actually ordered for delivery during the term of the contract, whether more or less than the quantities shown.

Item Number	Estimated Quantity	Unit of Measure	Description	Unit Cost	Extended Total Amount	Inventory Subcode (DOH Use Only) (Class 019 Type 008)	
FLEXIBLE PLASTIC CHANNELIZER CONES							
"55 MPH OR LESS ROADWAY" CHANNELIZER CONES							
1	100	each	Complete Flexible Plastic Channelizer Cone, to include sheeting (pre-applied), and rubber base	\$23.86	\$2386.00	080614	
2	1	each	Replacement Flexible Plastic Channelizer Cone, to include sheeting pre-applied. Model supplied shall be same as model supplied under Item #1. (CHANNELIZER CONE ONLY)	\$15.31	\$ 15.31	080616	
3	1	each	Replacement Flexible Plastic Channelizer Cone rubber base. Model supplied shall be same as model supplied under Item #1. (BASE ONLY)	\$ 8.55	\$ 8.55	080617	
CONTRACT TOTAL					→	\$2409.86	

DOH PERSONNEL PLEASE NOTE: ITEMS SUPPLIED ARE INTENDED FOR USE ONLY ON ROADWAYS WITH A NORMAL POSTED SPEED LIMIT OF 55 MPH OR LESS. ITEMS 1 AND 3 INCLUDE A OCTAGONAL BASE.

The Traffic Engineering Division has established a online form in order for District personnel to submit a documented report to the Traffic Engineering Division regarding issues associated with material orders. This form is intended to serve as a manner in which District personnel may quickly and easily submit a documented report to the Traffic Engineering Division regarding issues associated with the ordering, delivery and receipt of materials ordered, quality issues with any of the materials received, and any issues associated with the reconciliation of orders. This form may also be used to report issues with the installation or post-installation performance of materials. This form is located in the "Traffic" section of the WVDOT intranet site (Click on "Traffic" on the left side of the page, then click on "PO Contract Report" on the left side of the page). The direct address for the location of this form is <http://sharepoint.wv.gov/sites/dot/highways/traffic/pocontractreport/Pages/default.aspx>. All reports submitted will be responded to by the Traffic Engineering Division. The Traffic Engineering Division will work with the individual at the District submitting the report to obtain additional needed facts or documentation such as photos or product samples, and will contact and work with the Contract Vendor and Materials Division if needed in order to reconcile the issues in a manner acceptable to all parties if possible. Typically, as a final step to address reported issues, the Traffic Engineering Division will complete and submit a WV-82 Vendor Performance Form in order to officially document any issues and their outcome. Once the report is submitted, an email verification will be automatically sent and an email notice will be sent to the Traffic Engineering Division. The initial point of contact for any submitted reports is Bruce Miller. If you have any questions or would like to follow up on the status of a report that has been submitted, please contact Mr. Miller at 558-9454 or bruce.f.miller@wv.gov.

PRODUCT COMPLIANCE CHECKLIST FORM

This form should be completed in its' entirety by the vendor, and submitted as part of the vendor's bid package.

CHANNELIZER CONES - 55 MPH OR LESS (ITEMS 1-3)

1) Channelizer Cone manufacturer: Work Area Protection Corp.

2) Trade name(s) and model number(s) of Channelizer Cones to be supplied: _____

3) Channelizer Cone APL lab approval number : 1394648

4) Manufacturer(s) and Series number(s) of sheeting(s) to be utilized : 3M Series 3300
3310 White and 3314 Orange

5) Sheeting APL lab approval number(s) : 1433736

6) Channelizer Cones supplied with horizontal, circumferential, alternating orange and white retroreflective stripes that are 6 inches wide?

Yes	No
X	

7) Channelizer Cones have a minimum of two orange and two white stripes with the top stripe being orange with any non-retroreflectorized spaces between the horizontal orange and white stripes not exceeding 1 inch?

Yes	No
X	

8) Sheeting used on Channelizer Cones is Type ASTM-IV material listed on the WVDOH APL for Retroreflective Sheetingings?

Yes	No
X	

9) Channelizer cone is listed on the Materials Division "Channelizer Cones". Approved Product List (APL)?

Yes	No
X	

10) Product bid for items 1-3 is a model listed within the "approved for use on roadways with a normal posted speed limit of 55 mph or less" section of the APL and is manufactured of low density polyethylene?

Yes	No
X	

11) Channelizer Cone is permanently stamped in a prominent location with the letters "WVDOH" a minimum of 1" in height?

Yes	No
X	

12) Channelizer Cone certified by the manufacturer to meet NCHRP-350 Requiremnts at test levels I, II, and III.

Yes	No
X	

PRINT NAME: Douglas S. Comstock

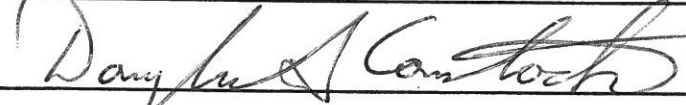
SIGN NAME: 

NAME OF VENDOR: Work Area Protection Corp.

DATE: 5/1/14



Ms. Barb Ray
Work Area Protection Corporation
2500 Production Dr.
St. Charles, IL 60174

April 16, 2014

Re: State of West Virginia RFQ 8514C2023

Dear Ms. Ray,

Work Area Protection Corporation has been certified by 3M Traffic Safety and Security Division to apply 3M™ Flexible Prismatic Reflective Sheeting Series 3300, APL lab approval number 1433736 (3310 white and 3314 orange) to the CC-42 4-6HIP Channelizer Cones as pertains to the State of West Virginia Dept. of Admin. Purchasing Division RFQ 8514C2023.

If you or your customers have questions regarding this certification, please contact me at the numbers below, or 3M Technical Service at 800-553-1380.

Sincerely,

A handwritten signature in cursive script that reads "MaryJo K. Lewis".

MaryJo K. Lewis | Division Quality Manager
3M Traffic Safety Systems Division
3M Center, 235-03-W-52 | St. Paul, MN 55144
Office: 651 736 2211 | Mobile: 651 331 6582 | Fax: 651 575 3055
mklewis1@mmm.com | www.3M.com



Work Area Protection Corporation
A SUBSIDIARY OF NEW ENTERPRISE STONE & LIME CO., INC.
2500 Production Drive • P.O. Box 4087 • St. Charles, IL 60174-9081
Phone 1-800-327-4417 • 1-630-377-9100 • Fax 1-630-377-9270

Certification of Crashworthiness
For Categories I, II and III Traffic Control Devices

The below listed traffic control device is certified as crashworthy in that it meets the evaluation criteria of the NCHRP Report 350, since the device is a type of device that is being certified as being crashworthy on the basis of years of demonstrably safe operational performance.

Work Area P/N	Description
C-42	42" Plastic Channelizer with or without rubber base, with or without stripes

Sincerely,

WORK AREA PROTECTION CORPORATION

Barbara Ray
Customer Service

State of Illinois

County of Kane

Being duly sworn upon oath says that the statements set forth are true and correct.

Subscribed and sworn before me on this

28th day April 2014.

Patricia L Willis Notary Public



Channelizer Cone

Tough enough
for any **work area**

Maximum visibility

Five-Tier design

Multi-purpose handle

Efficient stacking

Easy transport

Secure base

**WORK
AREA**

Specifications

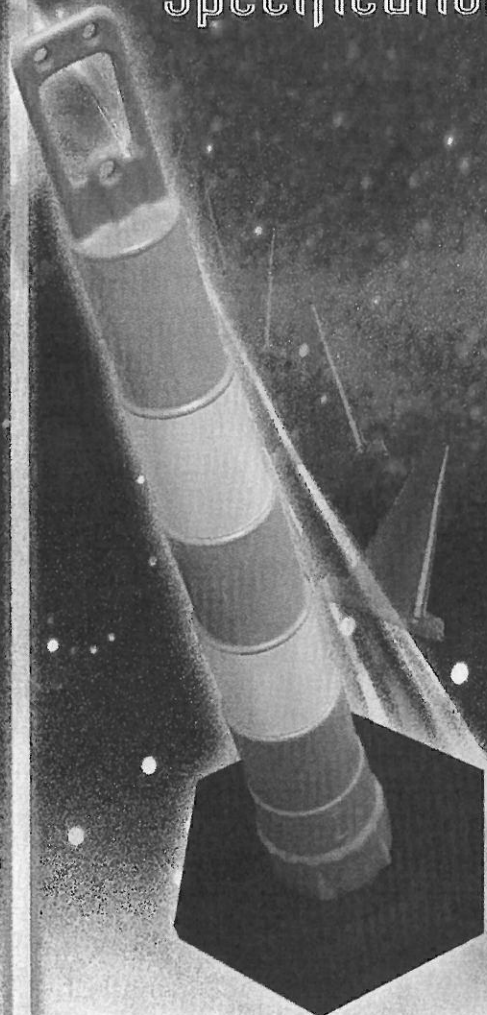

Part #	C-42
Material:	Linear Low-Density Polyethylene
Color:	UV Stabilized Highway Orange
Height:	42" (1.07m)
Weight:	3.0 lbs. (1.36kg.) approx.
Thickness:	.080" (2 mm)





Fracture-Resistant Handle

Features

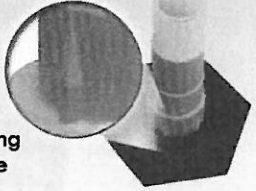

Locking Base



Signs

Applications



Lights

Part #	Weight	Height	Dimension	Hole
CB-16	16 lbs. (7.26kg)	2.4" (60mm)	17.75" Hex (451mm)	7.625" (194mm)
CB-30	30 lbs. (13.6kg)	2.4" (60mm)	16"x26" (406mm x 660mm)	7.625" (194mm)

ALL BASES ARE MADE OF 100% RECYCLED TIRE RUBBER.

Re-routing traffic has never been safer than with Work Area Protection's Channelizer Cones. Their trim-line design provides compact delineation which is ideal for detours, construction projects, concerts, sporting events, airports, etc. These durable and highly-visible channelizers come with or without reflective sheeting. A tapered, fracture-resistant handle provides for added strength, easy pickup and the mounting of lights and signs. The vertical sheeting surface has a five-tier, telescopic design which promotes ease of stacking. Anti-rotation ribs at the bottom make for a stable, secure attachment to the base. A rugged, recycled rubber base provides stability and support with designed-in features to enhance skid resistance, stacking and handling.



WORK AREA PROTECTION CORPORATION

www.workareaprotection.com e-mail: workarea@workareaprotection.com

A Division of Stabler Companies, Inc.
2500 Production Drive P.O. Box 4087
St. Charles, IL 60174-9081

630-377-9100
Fax: 630-377-9270
Ordering: 800-327-4417

VIEW top_1-top_1

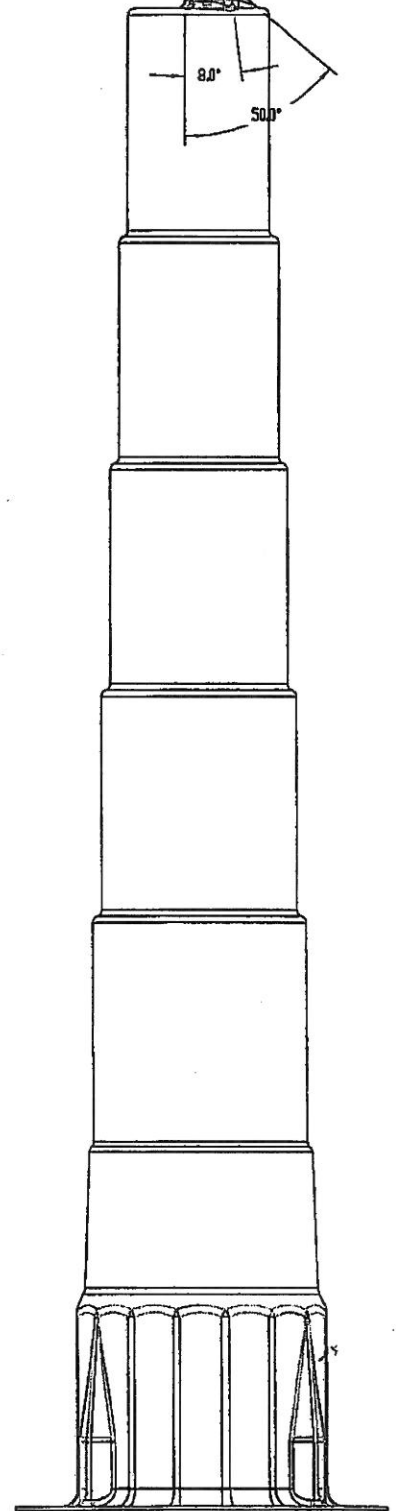
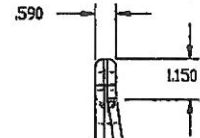
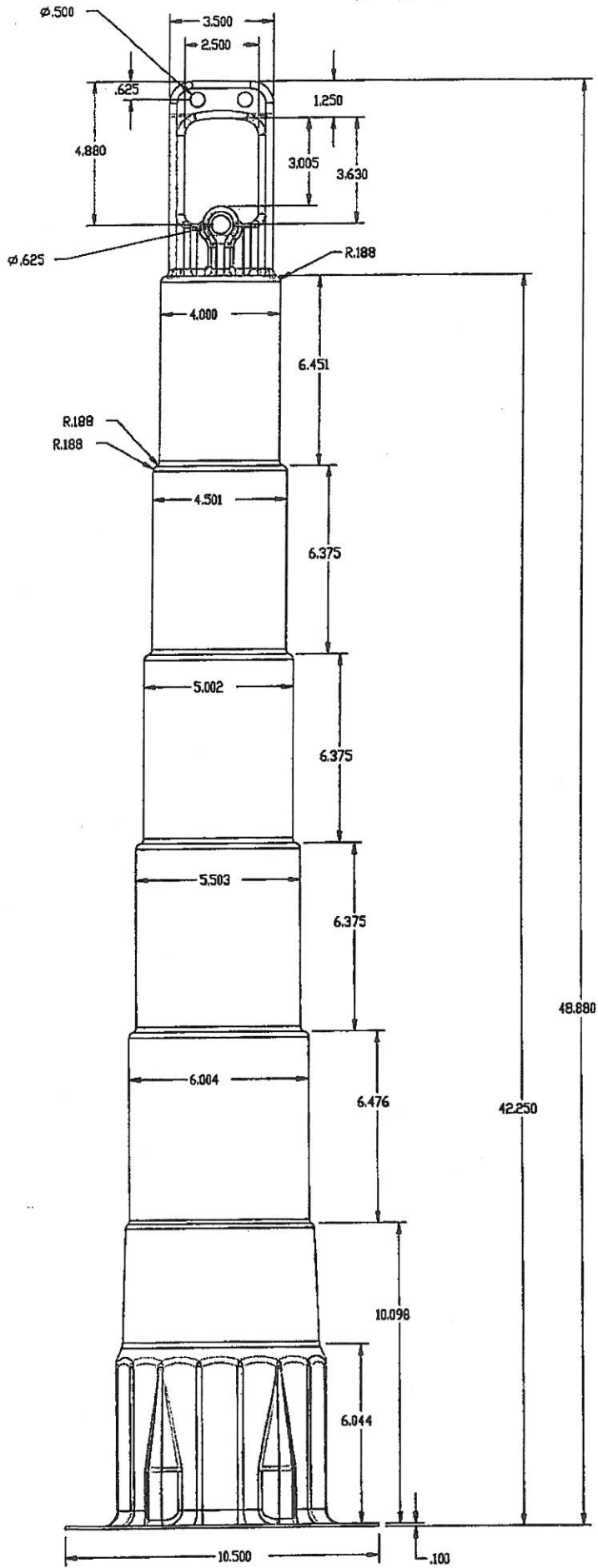

VIEW right_1-right_1

CHANNELIZER SPECIFICATIONS

Material	Linear Low Density Polyethylene
Color	Ultra-violet stabilized highway orange
Height (Cone)	42"-1.07m
Height (Overall)	48.75" - 1.24m
Weight (approx)	3 Lb. -1.36 Kg.
Wall Thickness (Nom.)	0.080" - 2mm

Band Circumferences	Square Feet/Square Centimeters					
	Inches	cm	6 inch	15cm	4 inch	10cm
#1	12.875	32.70	0.54	498	0.36	332
#2	14.375	36.51	0.60	556	0.40	371
#3	16	40.64	0.67	619	0.44	413
#4	17.625	44.77	0.73	682	0.49	455
#5	19.25	48.90	0.80	745	0.53	497

BASE SPECIFICATIONS

Model

CB4230

Material 100% recycled tire rubber
 Polyurethane Binder instead of Latex Binder to increase weatherization properties and maintain shear strength of rubber
 Width 16" - 406mm
 Length 26" - 660mm
 Height 2.4" - 60mm
 Hole 7.625"-194mm
 Handles (2) 1.5" x 4" - 38mm x 102mm
 Weight (nom.) 30 Lb. - 13.6kg
 Center hole recessed on bottom to capture bottom flange of channelizer cone
 4 Stacking lugs engage bottom of base to lock stacks for transportation

Model

CB4216

Material 100% recycled tire rubber
 Polyurethane Binder instead of Latex Binder to increase weatherization properties and maintain shear strength of rubber
 Hexagon 17.75" - 451 mm
 Height 2.4" - 60mm
 Hole 7.625" - 194mm
 Weight (nom.) 16Lb. - 7.3kg
 Center hole recessed on bottom to capture bottom flange of channelizer cone
 Top Ring engages bottom of base to lock stacks for transportation

BOTTOM VIEW

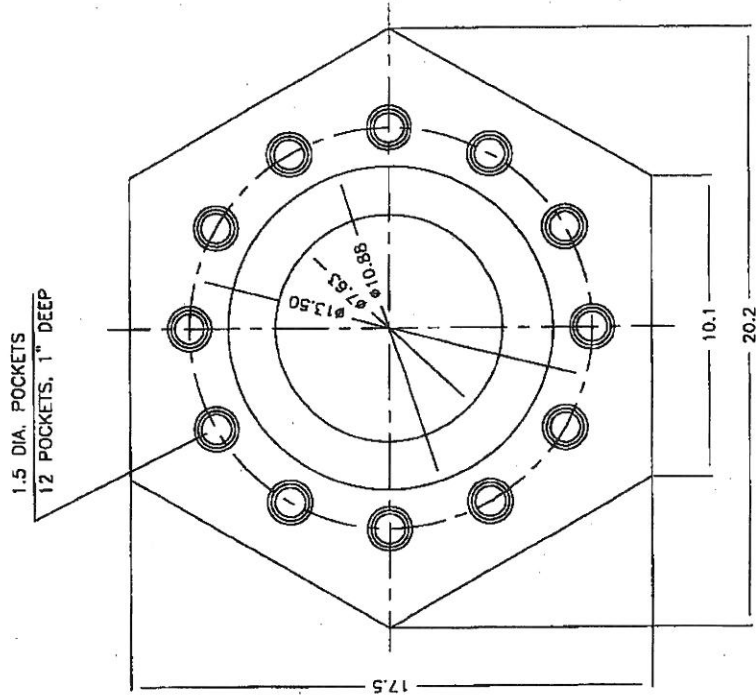

SECTION A-A

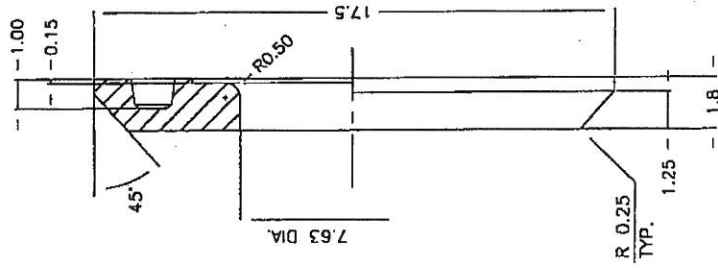

TOP VIEW

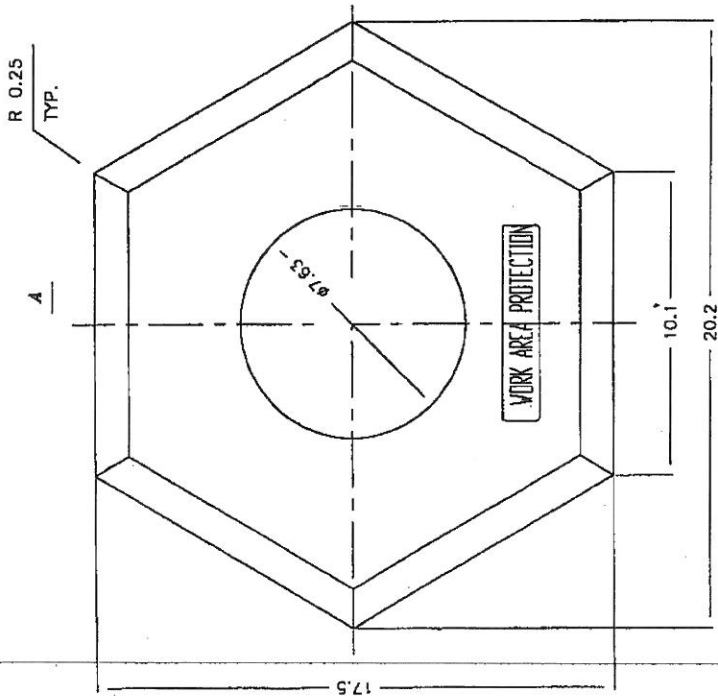

State of West Virginia VENDOR PREFERENCE CERTIFICATE

Certification and application* is hereby made for Preference in accordance with **West Virginia Code**, §5A-3-37. (Does not apply to construction contracts). **West Virginia Code**, §5A-3-37, provides an opportunity for qualifying vendors to request (at the time of bid) preference for their residency status. Such preference is an evaluation method only and will be applied only to the cost bid in accordance with the **West Virginia Code**. This certificate for application is to be used to request such preference. The Purchasing Division will make the determination of the Resident Vendor Preference, if applicable.

1. **Application is made for 2.5% resident vendor preference for the reason checked:**
 Bidder is an individual resident vendor and has resided continuously in West Virginia for four (4) years immediately preceding the date of this certification; **or**,
 Bidder is a partnership, association or corporation resident vendor and has maintained its headquarters or principal place of business continuously in West Virginia for four (4) years immediately preceding the date of this certification; or 80% of the ownership interest of Bidder is held by another individual, partnership, association or corporation resident vendor who has maintained its headquarters or principal place of business continuously in West Virginia for four (4) years immediately preceding the date of this certification; **or**,
 Bidder is a nonresident vendor which has an affiliate or subsidiary which employs a minimum of one hundred state residents and which has maintained its headquarters or principal place of business within West Virginia continuously for the four (4) years immediately preceding the date of this certification; **or**,
2. **Application is made for 2.5% resident vendor preference for the reason checked:**
 Bidder is a resident vendor who certifies that, during the life of the contract, on average at least 75% of the employees working on the project being bid are residents of West Virginia who have resided in the state continuously for the two years immediately preceding submission of this bid; **or**,
3. **Application is made for 2.5% resident vendor preference for the reason checked:**
 Bidder is a nonresident vendor employing a minimum of one hundred state residents or is a nonresident vendor with an affiliate or subsidiary which maintains its headquarters or principal place of business within West Virginia employing a minimum of one hundred state residents who certifies that, during the life of the contract, on average at least 75% of the employees or Bidder's affiliate's or subsidiary's employees are residents of West Virginia who have resided in the state continuously for the two years immediately preceding submission of this bid; **or**,
4. **Application is made for 5% resident vendor preference for the reason checked:**
 Bidder meets either the requirement of both subdivisions (1) and (2) or subdivision (1) and (3) as stated above; **or**,
5. **Application is made for 3.5% resident vendor preference who is a veteran for the reason checked:**
 Bidder is an individual resident vendor who is a veteran of the United States armed forces, the reserves or the National Guard and has resided in West Virginia continuously for the four years immediately preceding the date on which the bid is submitted; **or**,
6. **Application is made for 3.5% resident vendor preference who is a veteran for the reason checked:**
 Bidder is a resident vendor who is a veteran of the United States armed forces, the reserves or the National Guard, if, for purposes of producing or distributing the commodities or completing the project which is the subject of the vendor's bid and continuously over the entire term of the project, on average at least seventy-five percent of the vendor's employees are residents of West Virginia who have resided in the state continuously for the two immediately preceding years.
7. **Application is made for preference as a non-resident small, women- and minority-owned business, in accordance with West Virginia Code §5A-3-59 and West Virginia Code of State Rules.**
 Bidder has been or expects to be approved prior to contract award by the Purchasing Division as a certified small, women- and minority-owned business.

Bidder understands if the Secretary of Revenue determines that a Bidder receiving preference has failed to continue to meet the requirements for such preference, the Secretary may order the Director of Purchasing to: (a) reject the bid; or (b) assess a penalty against such Bidder in an amount not to exceed 5% of the bid amount and that such penalty will be paid to the contracting agency or deducted from any unpaid balance on the contract or purchase order.

By submission of this certificate, Bidder agrees to disclose any reasonably requested information to the Purchasing Division and authorizes the Department of Revenue to disclose to the Director of Purchasing appropriate information verifying that Bidder has paid the required business taxes, provided that such information does not contain the amounts of taxes paid nor any other information deemed by the Tax Commissioner to be confidential.

Under penalty of law for false swearing (West Virginia Code, §61-5-3), Bidder hereby certifies that this certificate is true and accurate in all respects; and that if a contract is issued to Bidder and if anything contained within this certificate changes during the term of the contract, Bidder will notify the Purchasing Division in writing immediately.

Bidder: _____ Signed: _____
 Date: _____ Title: _____

STATE OF WEST VIRGINIA
Purchasing Division

PURCHASING AFFIDAVIT

MANDATE: Under W. Va. Code §5A-3-10a, no contract or renewal of any contract may be awarded by the state or any of its political subdivisions to any vendor or prospective vendor when the vendor or prospective vendor or a related party to the vendor or prospective vendor is a debtor and: (1) the debt owed is an amount greater than one thousand dollars in the aggregate; or (2) the debtor is in employer default.

EXCEPTION: The prohibition listed above does not apply where a vendor has contested any tax administered pursuant to chapter eleven of the W. Va. Code, workers' compensation premium, permit fee or environmental fee or assessment and the matter has not become final or where the vendor has entered into a payment plan or agreement and the vendor is not in default of any of the provisions of such plan or agreement.

DEFINITIONS:

"Debt" means any assessment, premium, penalty, fine, tax or other amount of money owed to the state or any of its political subdivisions because of a judgment, fine, permit violation, license assessment, defaulted workers' compensation premium, penalty or other assessment presently delinquent or due and required to be paid to the state or any of its political subdivisions, including any interest or additional penalties accrued thereon.

"Employer default" means having an outstanding balance or liability to the old fund or to the uninsured employers' fund or being in policy default, as defined in W. Va. Code § 23-2c-2, failure to maintain mandatory workers' compensation coverage, or failure to fully meet its obligations as a workers' compensation self-insured employer. An employer is not in employer default if it has entered into a repayment agreement with the Insurance Commissioner and remains in compliance with the obligations under the repayment agreement.

"Related party" means a party, whether an individual, corporation, partnership, association, limited liability company or any other form or business association or other entity whatsoever, related to any vendor by blood, marriage, ownership or contract through which the party has a relationship of ownership or other interest with the vendor so that the party will actually or by effect receive or control a portion of the benefit, profit or other consideration from performance of a vendor contract with the party receiving an amount that meets or exceed five percent of the total contract amount.

AFFIRMATION: By signing this form, the vendor's authorized signer affirms and acknowledges under penalty of law for false swearing (W. Va. Code §61-5-3) that neither vendor nor any related party owe a debt as defined above and that neither vendor nor any related party are in employer default as defined above, unless the debt or employer default is permitted under the exception above.

WITNESS THE FOLLOWING SIGNATURE:

Vendor's Name: Work Area Protection Corp.

Authorized Signature: *Daryl A. Comstock* Date: 5/1/14

State of Illinois

County of Kane, to-wit:

Taken, subscribed, and sworn to before me this 1st day of May, 2014.

My Commission expires 3/9/15, 20 .

AFFIX SEAL HERE

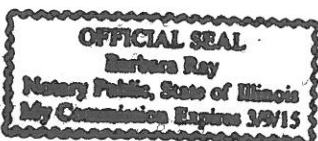

NOTARY PUBLIC

Barbara Ray
Purchasing Affidavit (Revised 07/01/2012)

NOTE:

Vendor and Notary's date must be the same.
Notary required to AFFIX SEAL on Purchasing Affidavit.