



State of West Virginia
 Department of Administration
 Purchasing Division
 2019 Washington Street East
 Post Office Box 50130
 Charleston, WV 25305-0130

Solicitation

NUMBER
7014EC03

PAGE
1

ADDRESS CORRESPONDENCE TO ATTENTION OF:
BUYER 33
304-558-2306

*709051756 304-346-5301

WV TRACTOR COMPANY
 PO BOX 473

CHARLESTON WV 25322

VENDOR

SHIP TO

DIVISION OF HIGHWAYS
 EQUIPMENT DIVISION
 ROUTE 33
 BRUSHY FORK ROAD
 BUCKHANNON, WV
 26201 304-472-1750

DATE PRINTED
11/07/2013

BID OPENING DATE: 12/11/2013

BID OPENING TIME 1:30PM

LINE	QUANTITY	UOP	CAT. NO.	ITEM NUMBER	UNIT PRICE	AMOUNT
0001	1	EA		025-50		
PROVIDE/AIR COMPRESSOR/PORTABLE/ELECTRIC REQUEST FOR QUOTATION (OPEN-END CONTRACT) THE WEST VIRGINIA PURCHASING DIVISION FOR THE AGENCY, THE WEST VIRGINIA DIVISION OF HIGHWAYS, IS SOLICITING BIDS FOR AN OPEN-END CONTRACT TO PROVIDE ELECTRIC PORTABLE AIR COMPRESSOR 185 C.F.M PER THE ATTACHED SPECIFICATIONS. ***** THIS IS THE END OF RFQ 7014EC03 ***** TOTAL:						
12/11/13 10:56:12AM West Virginia Purchasing Division						

SIGNATURE <i>Paul W. Gray</i>	TELEPHONE 304-346-5301	DATE 12-6-2013
TITLE President	FEIN 550621655	ADDRESS CHANGES TO BE NOTED ABOVE

WHEN RESPONDING TO SOLICITATION, INSERT NAME AND ADDRESS IN SPACE ABOVE LABELED 'VENDOR'

All Vendors should arrive prior to the starting time for the pre-bid. Vendors who arrive after the starting time but prior to the end of the pre-bid will be permitted to sign in, but are charged with knowing all matters discussed at the pre-bid.

Questions submitted at least five business days prior to a scheduled pre-bid will be discussed at the pre-bid meeting if possible. Any discussions or answers to questions at the pre-bid meeting are preliminary in nature and are non-binding. Official and binding answers to questions will be published in a written addendum to the Solicitation prior to bid opening.

4. **VENDOR QUESTION DEADLINE:** Vendors may submit questions relating to this Solicitation to the Purchasing Division. Questions must be submitted in writing. All questions must be submitted on or before the date listed below and to the address listed below in order to be considered. A written response will be published in a Solicitation addendum if a response is possible and appropriate. Non-written discussions, conversations, or questions and answers regarding this Solicitation are preliminary in nature and are non-binding.

Question Submission Deadline: November 29, 2013 at 5:00 PM EST

Submit Questions to: Crystal Rink
2019 Washington Street, East
Charleston, WV 25305
Fax: 304-558-2402
Email: Crystal.G.Rink@wv.gov

5. **VERBAL COMMUNICATION:** Any verbal communication between the Vendor and any State personnel is not binding, including that made at the mandatory pre-bid conference. Only information issued in writing and added to the Solicitation by an official written addendum by the Purchasing Division is binding.
6. **BID SUBMISSION:** All bids must be signed and delivered by the Vendor to the Purchasing Division at the address listed below on or before the date and time of the bid opening. Any bid received by the Purchasing Division staff is considered to be in the possession of the Purchasing Division and will not be returned for any reason. The bid delivery address is:

Department of Administration, Purchasing Division
2019 Washington Street East
Charleston, WV 25305-0130

INSTRUCTIONS TO VENDORS SUBMITTING BIDS

1. **REVIEW DOCUMENTS THOROUGHLY:** The attached documents contain a solicitation for bids. Please read these instructions and all documents attached in their entirety. These instructions provide critical information about requirements that if overlooked could lead to disqualification of a Vendor's bid. All bids must be submitted in accordance with the provisions contained in these instructions and the Solicitation. Failure to do so may result in disqualification of Vendor's bid.
2. **MANDATORY TERMS:** The Solicitation may contain mandatory provisions identified by the use of the words "must," "will," and "shall." Failure to comply with a mandatory term in the Solicitation will result in bid disqualification.
3. **PREBID MEETING:** The item identified below shall apply to this Solicitation.

A pre-bid meeting will not be held prior to bid opening.

A **NON-MANDATORY PRE-BID** meeting will be held at the following place and time:

A **MANDATORY PRE-BID** meeting will be held at the following place and time:

November 19, 2013 at 12:00 PM EST

2019 Washington Street, East
Charleston, WV 25305

All Vendors submitting a bid must attend the mandatory pre-bid meeting. Failure to attend the mandatory pre-bid meeting shall result in disqualification of the Vendor's bid. No one person attending the pre-bid meeting may represent more than one Vendor.

An attendance sheet provided at the pre-bid meeting shall serve as the official document verifying attendance. The State will not accept any other form of proof or documentation to verify attendance. Any person attending the pre-bid meeting on behalf of a Vendor must list on the attendance sheet his or her name and the name of the Vendor he or she is representing. Additionally, the person attending the pre-bid meeting should include the Vendor's E-Mail address, phone number, and Fax number on the attendance sheet. It is the Vendor's responsibility to locate the attendance sheet and provide the required information. Failure to complete the attendance sheet as required may result in disqualification of Vendor's bid.

The bid should contain the information listed below on the face of the envelope or the bid may not be considered:

SEALED BID

BUYER: _____ #33 Crystal Rink

SOLICITATION NO.: _____ 7014EC03

BID OPENING DATE: _____ 12-11-2013

BID OPENING TIME: _____ 1:30 PM

FAX NUMBER: _____ 304-346-5305

In the event that Vendor is responding to a request for proposal, the Vendor shall submit one original technical and one original cost proposal plus _____ convenience copies of each to the Purchasing Division at the address shown above. Additionally, the Vendor should identify the bid type as either a technical or cost proposal on the face of each bid envelope submitted in response to a request for proposal as follows:

BID TYPE: Technical
 Cost

7. **BID OPENING:** Bids submitted in response to this Solicitation will be opened at the location identified below on the date and time listed below. Delivery of a bid after the bid opening date and time will result in bid disqualification. For purposes of this Solicitation, a bid is considered delivered when time stamped by the official Purchasing Division time clock.

Bid Opening Date and Time: December 11, 2013 at 1:30 PM EST

Bid Opening Location: Department of Administration, Purchasing Division
 2019 Washington Street East
 Charleston, WV 25305-0130

8. **ADDENDUM ACKNOWLEDGEMENT:** Changes or revisions to this Solicitation will be made by an official written addendum issued by the Purchasing Division. Vendor should acknowledge receipt of all addenda issued with this Solicitation by completing an Addendum Acknowledgment Form, a copy of which is included herewith. Failure to acknowledge addenda may result in bid disqualification. The addendum acknowledgement should be submitted with the bid to expedite document processing.
9. **BID FORMATTING:** Vendor should type or electronically enter the information onto its bid to prevent errors in the evaluation. Failure to type or electronically enter the information may result in bid disqualification.

GENERAL TERMS AND CONDITIONS:

1. **CONTRACTUAL AGREEMENT:** Issuance of a Purchase Order signed by the Purchasing Division Director, or his designee, and approved as to form by the Attorney General's office constitutes acceptance of this Contract made by and between the State of West Virginia and the Vendor. Vendor's signature on its bid signifies Vendor's agreement to be bound by and accept the terms and conditions contained in this Contract.

2. **DEFINITIONS:** As used in this Solicitation/Contract, the following terms shall have the meanings attributed to them below. Additional definitions may be found in the specifications included with this Solicitation/Contract.
 - 2.1 **"Agency" or "Agencies"** means the agency, board, commission, or other entity of the State of West Virginia that is identified on the first page of the Solicitation or any other public entity seeking to procure goods or services under this Contract.

 - 2.2 **"Contract"** means the binding agreement that is entered into between the State and the Vendor to provide the goods and services requested in the Solicitation.

 - 2.3 **"Director"** means the Director of the West Virginia Department of Administration, Purchasing Division.

 - 2.4 **"Purchasing Division"** means the West Virginia Department of Administration, Purchasing Division.

 - 2.5 **"Purchase Order"** means the document signed by the Agency and the Purchasing Division, and approved as to form by the Attorney General, that identifies the Vendor as the successful bidder and Contract holder.

 - 2.6 **"Solicitation"** means the official solicitation published by the Purchasing Division and identified by number on the first page thereof.

 - 2.7 **"State"** means the State of West Virginia and/or any of its agencies, commissions, boards, etc. as context requires.

 - 2.8 **"Vendor" or "Vendors"** means any entity submitting a bid in response to the Solicitation, the entity that has been selected as the lowest responsible bidder, or the entity that has been awarded the Contract as context requires.

3. **CONTRACT TERM; RENEWAL; EXTENSION:** The term of this Contract shall be determined in accordance with the category that has been identified as applicable to this Contract below:



Term Contract

Initial Contract Term: This Contract becomes effective on
and extends for a period of 1 year(s).

Renewal Term: This Contract may be renewed upon the mutual written consent of the Agency, and the Vendor, with approval of the Purchasing Division and the Attorney General's office (Attorney General approval is as to form only). Any request for renewal must be submitted to the Purchasing Division Director thirty (30) days prior to the expiration date of the initial contract term or appropriate renewal term. A Contract renewal shall be in accordance with the terms and conditions of the original contract. Renewal of this Contract is limited to 2 successive one (1) year periods. Automatic renewal of this Contract is prohibited. Notwithstanding the foregoing, Purchasing Division approval is not required on agency delegated or exempt purchases. Attorney General approval may be required for vendor terms and conditions.

Reasonable Time Extension: At the sole discretion of the Purchasing Division Director, and with approval from the Attorney General's office (Attorney General approval is as to form only), this Contract may be extended for a reasonable time after the initial Contract term or after any renewal term as may be necessary to obtain a new contract or renew this Contract. Any reasonable time extension shall not exceed twelve (12) months. Vendor may avoid a reasonable time extension by providing the Purchasing Division Director with written notice of Vendor's desire to terminate this Contract 30 days prior to the expiration of the then current term. During any reasonable time extension period, the Vendor may terminate this Contract for any reason upon giving the Purchasing Division Director 30 days written notice. Automatic extension of this Contract is prohibited. Notwithstanding the foregoing, Purchasing Division approval is not required on agency delegated or exempt purchases, but Attorney General approval may be required.

Release Order Limitations: In the event that this contract permits release orders, a release order may only be issued during the time this Contract is in effect. Any release order issued within one year of the expiration of this Contract shall be effective for one year from the date the release order is issued. No release order may be extended beyond one year after this Contract has expired.



Fixed Period Contract: This Contract becomes effective upon Vendor's receipt of the notice to proceed and must be completed within _____ days.

- One Time Purchase:** The term of this Contract shall run from the issuance of the Purchase Order until all of the goods contracted for have been delivered, but in no event shall this Contract extend for more than one fiscal year.
- Other:** See attached.
4. **NOTICE TO PROCEED:** Vendor shall begin performance of this Contract immediately upon receiving notice to proceed unless otherwise instructed by the Agency. Unless otherwise specified, the fully executed Purchase Order will be considered notice to proceed
5. **QUANTITIES:** The quantities required under this Contract shall be determined in accordance with the category that has been identified as applicable to this Contract below.
- Open End Contract:** Quantities listed in this Solicitation are approximations only, based on estimates supplied by the Agency. It is understood and agreed that the Contract shall cover the quantities actually ordered for delivery during the term of the Contract, whether more or less than the quantities shown.
- Service:** The scope of the service to be provided will be more clearly defined in the specifications included herewith.
- Combined Service and Goods:** The scope of the service and deliverable goods to be provided will be more clearly defined in the specifications included herewith.
- One Time Purchase:** This Contract is for the purchase of a set quantity of goods that are identified in the specifications included herewith. Once those items have been delivered, no additional goods may be procured under this Contract without an appropriate change order approved by the Vendor, Agency, Purchasing Division, and Attorney General's office.
6. **PRICING:** The pricing set forth herein is firm for the life of the Contract, unless specified elsewhere within this Solicitation/Contract by the State. A Vendor's inclusion of price adjustment provisions in its bid, without an express authorization from the State in the Solicitation to do so, may result in bid disqualification.
7. **EMERGENCY PURCHASES:** The Purchasing Division Director may authorize the Agency to purchase goods or services in the open market that Vendor would otherwise provide under this Contract if those goods or services are for immediate or expedited delivery in an emergency. Emergencies shall include, but are not limited to, delays in transportation or an unanticipated increase in the volume of work. An emergency purchase in the open market, approved by the Purchasing Division Director, shall not constitute of breach of this Contract and shall not entitle the Vendor to any form of compensation or damages. This provision does not excuse the State from fulfilling its obligations under a One Time Purchase contract.
8. **REQUIRED DOCUMENTS:** All of the items checked below must be provided to the Purchasing Division by the Vendor as specified below.

BID BOND: All Vendors shall furnish a bid bond in the amount of five percent (5%) of the total amount of the bid protecting the State of West Virginia. The bid bond must be submitted with the bid.

PERFORMANCE BOND: The apparent successful Vendor shall provide a performance bond in the amount of . The performance bond must be issued and received by the Purchasing Division prior to Contract award. On construction contracts, the performance bond must be 100% of the Contract value.

LABOR/MATERIAL PAYMENT BOND: The apparent successful Vendor shall provide a labor/material payment bond in the amount of 100% of the Contract value. The labor/material payment bond must be issued and delivered to the Purchasing Division prior to Contract award.

In lieu of the Bid Bond, Performance Bond, and Labor/Material Payment Bond, the Vendor may provide certified checks, cashier's checks, or irrevocable letters of credit. Any certified check, cashier's check, or irrevocable letter of credit provided in lieu of a bond must be of the same amount and delivered on the same schedule as the bond it replaces. A letter of credit submitted in lieu of a performance and labor/material payment bond will only be allowed for projects under \$100,000. Personal or business checks are not acceptable.

MAINTENANCE BOND: The apparent successful Vendor shall provide a two (2) year maintenance bond covering the roofing system. The maintenance bond must be issued and delivered to the Purchasing Division prior to Contract award.

WORKERS' COMPENSATION INSURANCE: The apparent successful Vendor shall have appropriate workers' compensation insurance and shall provide proof thereof upon request.

INSURANCE: The apparent successful Vendor shall furnish proof of the following insurance prior to Contract award and shall list the state as a certificate holder:

Commercial General Liability Insurance:
or more.

Builders Risk Insurance: builders risk – all risk insurance in an amount equal to 100% of the amount of the Contract.

The apparent successful Vendor shall also furnish proof of any additional insurance requirements contained in the specifications prior to Contract award regardless of whether or not that insurance requirement is listed above.

LICENSE(S) / CERTIFICATIONS / PERMITS: In addition to anything required under the Section entitled Licensing, of the General Terms and Conditions, the apparent successful Vendor shall furnish proof of the following licenses, certifications, and/or permits prior to Contract award, in a form acceptable to the Purchasing Division.

The apparent successful Vendor shall also furnish proof of any additional licenses or certifications contained in the specifications prior to Contract award regardless of whether or not that requirement is listed above.

9. **LITIGATION BOND:** The Director reserves the right to require any Vendor that files a protest of an award to submit a litigation bond in the amount equal to one percent of the lowest bid submitted or \$5,000, whichever is greater. The entire amount of the bond shall be forfeited if the hearing officer determines that the protest was filed for frivolous or improper purpose, including but not limited to, the purpose of harassing, causing unnecessary delay, or needless expense for the Agency. All litigation bonds shall be made payable to the Purchasing Division. In lieu of a bond, the protester may submit a cashier's check or certified check payable to the Purchasing Division. Cashier's or certified checks will be deposited with and held by the State Treasurer's office. If it is determined that the protest has not been filed for frivolous or improper purpose, the bond or deposit shall be returned in its entirety.

10. **ALTERNATES:** Any model, brand, or specification listed herein establishes the acceptable level of quality only and is not intended to reflect a preference for, or in any way favor, a particular brand or vendor. Vendors may bid alternates to a listed model or brand provided that the alternate is at least equal to the model or brand and complies with the required specifications. The equality of any alternate being bid shall be determined by the State at its sole discretion. Any Vendor bidding an alternate model or brand should clearly identify the alternate items in its bid and should include manufacturer's specifications, industry literature, and/or any other relevant documentation demonstrating the equality of the alternate items. Failure to provide information for alternate items may be grounds for rejection of a Vendor's bid.

11. **EXCEPTIONS AND CLARIFICATIONS:** The Solicitation contains the specifications that shall form the basis of a contractual agreement. Vendor shall clearly mark any exceptions, clarifications, or

other proposed modifications in its bid. Exceptions to, clarifications of, or modifications of a requirement or term and condition of the Solicitation may result in bid disqualification.

12. LIQUIDATED DAMAGES: Vendor shall pay liquidated damages in the amount
NA for NA

This clause shall in no way be considered exclusive and shall not limit the State or Agency's right to pursue any other available remedy.

- 13. ACCEPTANCE/REJECTION:** The State may accept or reject any bid in whole, or in part. Vendor's signature on its bid signifies acceptance of the terms and conditions contained in the Solicitation and Vendor agrees to be bound by the terms of the Contract, as reflected in the Purchase Order, upon receipt.
- 14. REGISTRATION:** Prior to Contract award, the apparent successful Vendor must be properly registered with the West Virginia Purchasing Division and must have paid the \$125 fee if applicable.
- 15. COMMUNICATION LIMITATIONS:** In accordance with West Virginia Code of State Rules §148-1-6.6, communication with the State of West Virginia or any of its employees regarding this Solicitation during the solicitation, bid, evaluation or award periods, except through the Purchasing Division, is strictly prohibited without prior Purchasing Division approval. Purchasing Division approval for such communication is implied for all agency delegated and exempt purchases.
- 16. FUNDING:** This Contract shall continue for the term stated herein, contingent upon funds being appropriated by the Legislature or otherwise being made available. In the event funds are not appropriated or otherwise made available, this Contract becomes void and of no effect beginning on July 1 of the fiscal year for which funding has not been appropriated or otherwise made available.
- 17. PAYMENT:** Payment in advance is prohibited under this Contract. Payment may only be made after the delivery and acceptance of goods or services. The Vendor shall submit invoices, in arrears, to the Agency at the address on the face of the purchase order labeled "Invoice To."
- 18. UNIT PRICE:** Unit prices shall prevail in cases of a discrepancy in the Vendor's bid.
- 19. DELIVERY:** All quotations are considered freight on board destination ("F.O.B. destination") unless alternate shipping terms are clearly identified in the bid. Vendor's listing of shipping terms that contradict the shipping terms expressly required by this Solicitation may result in bid disqualification.
- 20. INTEREST:** Interest attributable to late payment will only be permitted if authorized by the West Virginia Code. Presently, there is no provision in the law for interest on late payments.
- 21. PREFERENCE:** Vendor Preference may only be granted upon written request and only in accordance with the West Virginia Code § 5A-3-37 and the West Virginia Code of State Rules. A Resident Vendor Certification form has been attached hereto to allow Vendor to apply for the preference. Vendor's

failure to submit the Resident Vendor Certification form with its bid will result in denial of Vendor Preference. Vendor Preference does not apply to construction projects.

22. **SMALL, WOMEN-OWNED, OR MINORITY-OWNED BUSINESSES:** For any solicitations publicly advertised for bid on or after July 1, 2012, in accordance with West Virginia Code §5A-3-37(a)(7) and W. Va. CSR § 148-22-9, any non-resident vendor certified as a small, women-owned, or minority-owned business under W. Va. CSR § 148-22-9 shall be provided the same preference made available to any resident vendor. Any non-resident small, women-owned, or minority-owned business must identify itself as such in writing, must submit that writing to the Purchasing Division with its bid, and must be properly certified under W. Va. CSR § 148-22-9 prior to submission of its bid to receive the preferences made available to resident vendors. Preference for a non-resident small, women-owned, or minority owned business shall be applied in accordance with W. Va. CSR § 148-22-9.
23. **TAXES:** The Vendor shall pay any applicable sales, use, personal property or any other taxes arising out of this Contract and the transactions contemplated thereby. The State of West Virginia is exempt from federal and state taxes and will not pay or reimburse such taxes.
24. **CANCELLATION:** The Purchasing Division Director reserves the right to cancel this Contract immediately upon written notice to the vendor if the materials or workmanship supplied do not conform to the specifications contained in the Contract. The Purchasing Division Director may cancel any purchase or Contract upon 30 days written notice to the Vendor in accordance with West Virginia Code of State Rules § 148-1-7.16.2.
25. **WAIVER OF MINOR IRREGULARITIES:** The Director reserves the right to waive minor irregularities in bids or specifications in accordance with West Virginia Code of State Rules § 148-1-4.6.
26. **TIME:** Time is of the essence with regard to all matters of time and performance in this Contract.
27. **APPLICABLE LAW:** This Contract is governed by and interpreted under West Virginia law without giving effect to its choice of law principles. Any information provided in specification manuals, or any other source, verbal or written, which contradicts or violates the West Virginia Constitution, West Virginia Code or West Virginia Code of State Rules is void and of no effect.
28. **COMPLIANCE:** Vendor shall comply with all applicable federal, state, and local laws, regulations and ordinances. By submitting a bid, Vendors acknowledge that they have reviewed, understand, and will comply with all applicable law.
29. **PREVAILING WAGE:** On any contract for the construction of a public improvement, Vendor and any subcontractors utilized by Vendor shall pay a rate or rates of wages which shall not be less than the fair minimum rate or rates of wages (prevailing wage), as established by the West Virginia Division of Labor under West Virginia Code §§ 21-5A-1 et seq. and available at <http://www.sos.wv.gov/administrative-law/wagerates/Pages/default.aspx>. Vendor shall be responsible for ensuring compliance with prevailing wage requirements and determining when prevailing wage

requirements are applicable. The required contract provisions contained in West Virginia Code of State Rules § 42-7-3 are specifically incorporated herein by reference.

- 30. ARBITRATION:** Any references made to arbitration contained in this Contract, Vendor's bid, or in any American Institute of Architects documents pertaining to this Contract are hereby deleted, void, and of no effect.
- 31. MODIFICATIONS:** This writing is the parties' final expression of intent. Notwithstanding anything contained in this Contract to the contrary, no modification of this Contract shall be binding without mutual written consent of the Agency, and the Vendor, with approval of the Purchasing Division and the Attorney General's office (Attorney General approval is as to form only). **No Change shall be implemented by the Vendor until such time as the Vendor receives an approved written change order from the Purchasing Division.**
- 32. WAIVER:** The failure of either party to insist upon a strict performance of any of the terms or provision of this Contract, or to exercise any option, right, or remedy herein contained, shall not be construed as a waiver or a relinquishment for the future of such term, provision, option, right, or remedy, but the same shall continue in full force and effect. Any waiver must be expressly stated in writing and signed by the waiving party.
- 33. SUBSEQUENT FORMS:** The terms and conditions contained in this Contract shall supersede any and all subsequent terms and conditions which may appear on any form documents submitted by Vendor to the Agency or Purchasing Division such as price lists, order forms, invoices, sales agreements, or maintenance agreements, and includes internet websites or other electronic documents. Acceptance or use of Vendor's forms does not constitute acceptance of the terms and conditions contained thereon.
- 34. ASSIGNMENT:** Neither this Contract nor any monies due, or to become due hereunder, may be assigned by the Vendor without the express written consent of the Agency, the Purchasing Division, the Attorney General's office (as to form only), and any other government agency or office that may be required to approve such assignments. Notwithstanding the foregoing, Purchasing Division approval may or may not be required on certain agency delegated or exempt purchases.
- 35. WARRANTY:** The Vendor expressly warrants that the goods and/or services covered by this Contract will: (a) conform to the specifications, drawings, samples, or other description furnished or specified by the Agency; (b) be merchantable and fit for the purpose intended; and (c) be free from defect in material and workmanship.
- 36. STATE EMPLOYEES:** State employees are not permitted to utilize this Contract for personal use and the Vendor is prohibited from permitting or facilitating the same.
- 37. BANKRUPTCY:** In the event the Vendor files for bankruptcy protection, the State of West Virginia may deem this Contract null and void, and terminate this Contract without notice.

38. [RESERVED]

39. CONFIDENTIALITY: The Vendor agrees that it will not disclose to anyone, directly or indirectly, any such personally identifiable information or other confidential information gained from the Agency, unless the individual who is the subject of the information consents to the disclosure in writing or the disclosure is made pursuant to the Agency's policies, procedures, and rules. Vendor further agrees to comply with the Confidentiality Policies and Information Security Accountability Requirements, set forth in <http://www.state.wv.us/admin/purchase/privacy/default.html>.

40. DISCLOSURE: Vendor's response to the Solicitation and the resulting Contract are considered public documents and will be disclosed to the public in accordance with the laws, rules, and policies governing the West Virginia Purchasing Division. Those laws include, but are not limited to, the Freedom of Information Act found in West Virginia Code § 29B-1-1 et seq.

If a Vendor considers any part of its bid to be exempt from public disclosure, Vendor must so indicate by specifically identifying the exempt information, identifying the exemption that applies, providing a detailed justification for the exemption, segregating the exempt information from the general bid information, and submitting the exempt information as part of its bid but in a segregated and clearly identifiable format. Failure to comply with the foregoing requirements will result in public disclosure of the Vendor's bid without further notice. A Vendor's act of marking all or nearly all of its bid as exempt is not sufficient to avoid disclosure and WILL NOT BE HONORED. Vendor's act of marking a bid or any part thereof as "confidential" or "proprietary" is not sufficient to avoid disclosure and WILL NOT BE HONORED. In addition, a legend or other statement indicating that all or substantially all of the bid is exempt from disclosure is not sufficient to avoid disclosure and WILL NOT BE HONORED. Vendor will be required to defend any claimed exemption for nondisclosure in the event of an administrative or judicial challenge to the State's nondisclosure. Vendor must indemnify the State for any costs incurred related to any exemptions claimed by Vendor. Any questions regarding the applicability of the various public records laws should be addressed to your own legal counsel prior to bid submission.

41. LICENSING: In accordance with West Virginia Code of State Rules §148-1-6.1.7, Vendor must be licensed and in good standing in accordance with any and all state and local laws and requirements by any state or local agency of West Virginia, including, but not limited to, the West Virginia Secretary of State's Office, the West Virginia Tax Department, West Virginia Insurance Commission, or any other state agency or political subdivision. Upon request, the Vendor must provide all necessary releases to obtain information to enable the Purchasing Division Director or the Agency to verify that the Vendor is licensed and in good standing with the above entities.

42. ANTITRUST: In submitting a bid to, signing a contract with, or accepting a Purchase Order from any agency of the State of West Virginia, the Vendor agrees to convey, sell, assign, or transfer to the State of West Virginia all rights, title, and interest in and to all causes of action it may now or hereafter acquire under the antitrust laws of the United States and the State of West Virginia for price fixing and/or unreasonable restraints of trade relating to the particular commodities or services purchased or acquired

by the State of West Virginia. Such assignment shall be made and become effective at the time the purchasing agency tenders the initial payment to Vendor.

- 43. VENDOR CERTIFICATIONS:** By signing its bid or entering into this Contract, Vendor certifies (1) that its bid was made without prior understanding, agreement, or connection with any corporation, firm, limited liability company, partnership, person or entity submitting a bid for the same material, supplies, equipment or services; (2) that its bid is in all respects fair and without collusion or fraud; (3) that this Contract is accepted or entered into without any prior understanding, agreement, or connection to any other entity that could be considered a violation of law; and (4) that it has reviewed this RFQ in its entirety, understands the requirements, terms and conditions, and other information contained herein. Vendor's signature on its bid also affirms that neither it nor its representatives have any interest, nor shall acquire any interest, direct or indirect, which would compromise the performance of its services hereunder. Any such interests shall be promptly presented in detail to the Agency.

The individual signing this bid on behalf of Vendor certifies that he or she is authorized by the Vendor to execute this bid or any documents related thereto on Vendor's behalf; that he or she is authorized to bind the Vendor in a contractual relationship; and that, to the best of his or her knowledge, the Vendor has properly registered with any State agency that may require registration.

- 44. PURCHASING CARD ACCEPTANCE:** The State of West Virginia currently utilizes a Purchasing Card program, administered under contract by a banking institution, to process payment for goods and services. The Vendor must accept the State of West Virginia's Purchasing Card for payment of all orders under this Contract unless the box below is checked.

Vendor is not required to accept the State of West Virginia's Purchasing Card as payment for all goods and services.

- 45. VENDOR RELATIONSHIP:** The relationship of the Vendor to the State shall be that of an independent contractor and no principal-agent relationship or employer-employee relationship is contemplated or created by this Contract. The Vendor as an independent contractor is solely liable for the acts and omissions of its employees and agents. Vendor shall be responsible for selecting, supervising, and compensating any and all individuals employed pursuant to the terms of this Solicitation and resulting contract. Neither the Vendor, nor any employees or subcontractors of the Vendor, shall be deemed to be employees of the State for any purpose whatsoever. Vendor shall be exclusively responsible for payment of employees and contractors for all wages and salaries, taxes, withholding payments, penalties, fees, fringe benefits, professional liability insurance premiums, contributions to insurance and pension, or other deferred compensation plans, including but not limited to, Workers' Compensation and Social Security obligations, licensing fees, *etc.* and the filing of all necessary documents, forms and returns pertinent to all of the foregoing. Vendor shall hold harmless the State, and shall provide the State and Agency with a defense against any and all claims including, but not limited to, the foregoing payments, withholdings, contributions, taxes, Social Security taxes, and employer income tax returns.

- 46. INDEMNIFICATION:** The Vendor agrees to indemnify, defend, and hold harmless the State and the Agency, their officers, and employees from and against: (1) Any claims or losses for services rendered

by any subcontractor, person, or firm performing or supplying services, materials, or supplies in connection with the performance of the Contract; (2) Any claims or losses resulting to any person or entity injured or damaged by the Vendor, its officers, employees, or subcontractors by the publication, translation, reproduction, delivery, performance, use, or disposition of any data used under the Contract in a manner not authorized by the Contract, or by Federal or State statutes or regulations; and (3) Any failure of the Vendor, its officers, employees, or subcontractors to observe State and Federal laws including, but not limited to, labor and wage and hour laws.

- 47. PURCHASING AFFIDAVIT:** In accordance with West Virginia Code § 5A-3-10a, all Vendors are required to sign, notarize, and submit the Purchasing Affidavit stating that neither the Vendor nor a related party owe a debt to the State in excess of \$1,000. The affidavit must be submitted prior to award, but should be submitted with the Vendor's bid. A copy of the Purchasing Affidavit is included herewith.
- 48. ADDITIONAL AGENCY AND LOCAL GOVERNMENT USE:** This Contract may be utilized by and extends to other agencies, spending units, and political subdivisions of the State of West Virginia; county, municipal, and other local government bodies; and school districts ("Other Government Entities"). This Contract shall be extended to the aforementioned Other Government Entities on the same prices, terms, and conditions as those offered and agreed to in this Contract. If the Vendor does not wish to extend the prices, terms, and conditions of its bid and subsequent contract to the Other Government Entities, the Vendor must clearly indicate such refusal in its bid. A refusal to extend this Contract to the Other Government Entities shall not impact or influence the award of this Contract in any manner.
- 49. CONFLICT OF INTEREST:** Vendor, its officers or members or employees, shall not presently have or acquire any interest, direct or indirect, which would conflict with or compromise the performance of its obligations hereunder. Vendor shall periodically inquire of its officers, members and employees to ensure that a conflict of interest does not arise. Any conflict of interest discovered shall be promptly presented in detail to the Agency.
- 50. REPORTS:** Vendor shall provide the Agency and/or the Purchasing Division with the following reports identified by a checked box below:
- Such reports as the Agency and/or the Purchasing Division may request. Requested reports may include, but are not limited to, quantities purchased, agencies utilizing the contract, total contract expenditures by agency, etc.
 - Quarterly reports detailing the total quantity of purchases in units and dollars, along with a listing of purchases by agency. Quarterly reports should be delivered to the Purchasing Division via email at purchasing.requisitions@wv.gov.
- 51. BACKGROUND CHECK:** In accordance with W. Va. Code § 15-2D-3, the Director of the Division of Protective Services shall require any service provider whose employees are regularly employed on the grounds or in the buildings of the Capitol complex or who have access to sensitive or critical information

to submit to a fingerprint-based state and federal background inquiry through the state repository. The service provider is responsible for any costs associated with the fingerprint-based state and federal background inquiry.

After the contract for such services has been approved, but before any such employees are permitted to be on the grounds or in the buildings of the Capitol complex or have access to sensitive or critical information, the service provider shall submit a list of all persons who will be physically present and working at the Capitol complex to the Director of the Division of Protective Services for purposes of verifying compliance with this provision.

The State reserves the right to prohibit a service provider's employees from accessing sensitive or critical information or to be present at the Capitol complex based upon results addressed from a criminal background check.

Service providers should contact the West Virginia Division of Protective Services by phone at (304)558-9911 for more information.

52. PREFERENCE FOR USE OF DOMESTIC STEEL PRODUCTS: Except when authorized by the Director of the Purchasing Division pursuant to W. Va. Code § 5A-3-56, no contractor may use or supply steel products for a State Contract Project other than those steel products made in the United States. A contractor who uses steel products in violation of this section may be subject to civil penalties pursuant to W. Va. Code § 5A-3-56. As used in this section:

- a. "State Contract Project" means any erection or construction of, or any addition to, alteration of or other improvement to any building or structure, including, but not limited to, roads or highways, or the installation of any heating or cooling or ventilating plants or other equipment, or the supply of and materials for such projects, pursuant to a contract with the State of West Virginia for which bids were solicited on or after June 6, 2001.
- b. "Steel Products" means products rolled, formed, shaped, drawn, extruded, forged, cast, fabricated or otherwise similarly processed, or processed by a combination of two or more or such operations, from steel made by the open heath, basic oxygen, electric furnace, Bessemer or other steel making process.

The Purchasing Division Director may, in writing, authorize the use of foreign steel products if:

- a. The cost for each contract item used does not exceed one tenth of one percent (.1%) of the total contract cost or two thousand five hundred dollars (\$2,500.00), whichever is greater. For the purposes of this section, the cost is the value of the steel product as delivered to the project; or
- b. The Director of the Purchasing Division determines that specified steel materials are not produced in the United States in sufficient quantity or otherwise are not reasonably available to meet contract requirements.

53. PREFERENCE FOR USE OF DOMESTIC ALUMINUM, GLASS, AND STEEL: In Accordance with W. Va. Code § 5-19-1 et seq., and W. Va. CSR § 148-10-1 et seq., for every contract or subcontract, subject to the limitations contained herein, for the construction, reconstruction, alteration, repair, improvement or maintenance of public works or for the purchase of any item of machinery or equipment to be used at sites of public works, only domestic aluminum, glass or steel products shall be supplied unless the spending officer determines, in writing, after the receipt of offers or bids, (1) that the cost of domestic aluminum, glass or steel products is unreasonable or inconsistent with the public interest of the State of West Virginia, (2) that domestic aluminum, glass or steel products are not produced in sufficient quantities to meet the contract requirements, or (3) the available domestic aluminum, glass, or steel do not meet the contract specifications. This provision only applies to public works contracts awarded in an amount more than fifty thousand dollars (\$50,000) or public works contracts that require more than ten thousand pounds of steel products.

The cost of domestic aluminum, glass, or steel products may be unreasonable if the cost is more than twenty percent (20%) of the bid or offered price for foreign made aluminum, glass, or steel products. If the domestic aluminum, glass or steel products to be supplied or produced in a “substantial labor surplus area”, as defined by the United States Department of Labor, the cost of domestic aluminum, glass, or steel products may be unreasonable if the cost is more than thirty percent (30%) of the bid or offered price for foreign made aluminum, glass, or steel products.

This preference shall be applied to an item of machinery or equipment, as indicated above, when the item is a single unit of equipment or machinery manufactured primarily of aluminum, glass or steel, is part of a public works contract and has the sole purpose or of being a permanent part of a single public works project. This provision does not apply to equipment or machinery purchased by a spending unit for use by that spending unit and not as part of a single public works project.

All bids and offers including domestic aluminum, glass or steel products that exceed bid or offer prices including foreign aluminum, glass or steel products after application of the preferences provided in this provision may be reduced to a price equal to or lower than the lowest bid or offer price for foreign aluminum, glass or steel products plus the applicable preference. If the reduced bid or offer prices are made in writing and supersede the prior bid or offer prices, all bids or offers, including the reduced bid or offer prices, will be reevaluated in accordance with this rule.

SPECIFICATIONS

1. **PURPOSE AND SCOPE:** The West Virginia Purchasing Division is soliciting bids On behalf of the West Virginia Division of Highways, Department of Transportation to establish an open-end contract for Air Compressor, Portable, Electric, 185 C.F.M.

2. **DEFINITIONS:** The terms listed below shall have the meanings assigned to them below. Additional definitions can be found in section 2 of the General Terms and Conditions.
 - 2.1 **“Contract Item” or “Contract Items”** means the list of items identified in Section 3, Subsection 1 below.
 - 2.2 **“Pricing Pages”** means the schedule of prices, estimated order quantity, and totals attached hereto as Exhibit A and used to evaluate the RFQ.
 - 2.3 **“RFQ”** means the official request for quotation published by the Purchasing Division and identified as 7014EC03.
 - 2.4 **“ASME”** means the American Society of Mechanical Engineers.
 - 2.5 **“PSIG”** means pounds per square inch gauge.
 - 2.6 **“CFM”** means cubic foot per minute.
 - 2.7 **“BHP”** means brake horse power.
 - 2.8 **“WVDOH”** means West Virginia Division of Highways.
 - 2.9 **“RPM”** means Revolutions per minute.

3. **GENERAL REQUIREMENTS:**
 - 3.1 **Contract Items and Mandatory Requirements:** Vendor shall provide Agency with the Contract Items listed below on an open-end and continuing basis. Contract Items must meet or exceed the mandatory requirements as shown below.
 - 3.1.1 **Compressor, Air, Portable, Electric, 185 C.F.M.**
 - 3.1.1.1 **General – Portable, electric air compressor general mandatory requirements must:**

3.1.1.1.1 Certify that unit offered will comply with Occupational Safety and Health Act of 1970 and subsequent amendments that are in effect at time the unit is manufactured.

3.1.1.2 Compressor – The following are mandatory requirements related to the compressor.

3.1.1.2.1 Compressor shall be single stage rotary screw type.

3.1.1.2.2 Shall have self contained, fully enclosed heavy duty portable air compressor.

3.1.1.2.3 Shall have free air capacity 185 CFM.

3.1.1.3 Air Receiver-The following are mandatory requirements related to the air receiver.

3.1.1.3.1 Air Receiver shall be ASME code construction and have a working pressure of 100 PSIG, minimum.

3.1.1.3.2 Air receiver capacity 1.06 cubic feet minimum with safety valve and two (2) $\frac{3}{4}$ inch service valves, universal type.

3.1.1.3.3 Discharge line shall be fitted with an automatic discharge moisture trap. Size and capacity shall be determined by manufacturer for compressor rating and located between air receiver and service valve.

3.1.1.3.4 Shall have two (2) discharge line lubricators - one (1) quart capacity each, to each outlet, fitted and easily accessible.

3.1.1.4 Engine – The following are mandatory requirements related to the engine.

3.1.1.4.1 Engine shall be diesel powered, water cooled.

3.1.1.4.2 Unit shall have a minimum of 49 BHP at a continuous rated speed of 2300 RPM minimum.

3.1.1.4.3 Shall have rain cap to protect engine and muffler.

3.1.1.5 Fuel Tank – The following are mandatory requirements related to the Fuel tank.

3.1.1.5.1 The fuel tank shall have a capacity 20 US gallon minimum.

3.1.1.6 Cooling System – The following are mandatory items related to the cooling system.

3.1.1.6.1 Cooling system shall be of sufficient to allow engine and compressor to operate at rated air delivery and pressure continuously.

3.1.1.6.2 Engine coolant shall be rated at -32 degrees F.

3.1.1.6.3 The solar panel generator array must recharge the battery bank at a rate of 2.5 hours sun to one (1) 24 hour period of usage.

3.1.1.7 Instrument Panel/Controls – The Following are mandatory items to be included in the units the instrument panel.

3.1.1.7.1 Tachometer, engine RPM.

3.1.1.7.2 Ammeter or voltmeter.

3.1.1.7.3 Engine temperature gauge.

3.1.1.7.4 Engine oil pressure gauge.

3.1.1.7.5 Discharge air pressure gauge.

3.1.1.7.6 Fuel gauge.

3.1.1.7.7 Hour Meter

3.1.1.7.8 Start and stop controls shall be located on control panel.

REQUEST FOR QUOTATION
RFQ 7014EC03 612 CLASS AIR COMPRESSOR, PORTABLE, ELECTRIC
185 C.F.M.

3.1.1.7.9 Operation, maintenance and instruction decals shall be located in a conspicuous place near controls.

3.1.1.7.10 Controls must be 0-100 percent demand type, controlling engine speed and intake of air compressor.

3.1.1.8 Trailer – The following are mandatory items related to the trailer.

3.1.1.8.1 Compressor shall be mounted on a two (2) wheeled type towing trailer.

3.1.1.8.2 Engine and compressor shall be frame mounted in a manner to minimize vibration.

3.1.1.8.3 Suspension shall be of sufficient strength and handling of unit at a towing speed of 55 MPH.

3.1.1.8.4 Shall have retractable, swivel type third wheel.

3.1.1.8.5 Tires shall be P205/75R15 load range C, highway tread. Must have wheel drop center 7 inches wide.

3.1.1.8.6 Hub shall be equipped with trailer wheel bearing protector (bearing must be Buddy Model 1980 or equal).

3.1.1.8.7 Shall have drawbar with pintle eye and safety chain.

3.1.1.8.8 Must have stop lights, tail lights, directional indicators, (LED type) license plate light and license plate bracket.

3.1.1.8.9 Shall have Cole Hersee No. 12081 (or approved equal) male plug for towing vehicle.

3.1.1.9 Lubrication – The following are mandatory items related to lubrication of air compressor.

3.1.1.9.1 Must have oil flooded or pressure type to provide sealing, lubrication, and cooling of air pump.

- 3.1.1.10 Oil Filter** – The following are mandatory requirements related to the oil filter.
- 3.1.1.10.1 Must have a oil filter replaceable element or spin-on flow type.
- 3.1.1.11 Air Intake** –The following are mandatory requirements related to the air intake.
- 3.1.1.11.1 Shall have air intake filter, dry type with maintenance signal.
- 3.1.1.12 Bearings** – The following are mandatory requirements related to the bearings.
- 3.1.1.12.1 Bearings must be anti-friction type, heaviest duty offered.
- 3.1.1.13 Electrical System** – The following are mandatory requirements related to the electrical system.
- 3.1.1.13.1 Must have a twelve (12) volt electrical system. heaviest duty system and batteries offered.
- 3.1.1.14 Safety Devices** – The following are mandatory requirements related to safety devices.
- 3.1.1.14.1 Shall have automatic blow-down valve.
 - 3.1.1.14.2 Engine shutdown devices shall be activated by high discharge air temperature, low engine oil pressure, and high engine temperature.
 - 3.1.1.14.3 Shall have excess air flow safety valve and a minimum pressure valve.
- 3.1.1.15 Accessories** – The following are mandatory requirements related to accessories.
- 3.1.1.15.1 Shall have service drain valve for air reservoir.
 - 3.1.1.15.2 Shall have manufacturers standard vandalism protection kit(s).

REQUEST FOR QUOTATION
RFQ 7014EC03 612 CLASS AIR COMPRESSOR, PORTABLE, ELECTRIC
185 C.F.M.

23

- 3.1.1.15.3 Must have lockable tool boxes.
- 3.1.1.15.4 Must have (1) set of replacement filters for compressor air and lube oil and engine air, fuel and lube oil, included with delivery of each unit.
- 3.1.1.15.5 Must have lifting bail, single point.
- 3.1.1.15.6 Must have twin hose reels capable of holding 50 foot x 1 inch outside diameter (O.D.) hose. (Hose supplied by the Division of Highways).
- 3.1.1.16 **Advertising** - The following are mandatory items related to advertising.
 - 3.1.1.16.1 Only one manufacturer's name decal, which must include the model number, may appear on the exterior of the unit. Logos created through the stamping or casting process of manufacture are also acceptable. No logos will interfere with the Divisions logo striping and decal.

4. CONTRACT AWARD:

- 4.1 Contract Award:** The Contract is intended to provide Agencies with a purchase price on all Contract Items. The Contract shall be awarded to the Vendor that provides the Contract Items meeting the required specifications for the lowest overall total cost as shown on the Pricing Pages.
- 4.2 Pricing Pages:** Vendor should complete the Pricing Pages (Exhibit A) by completing the Year, Make, and Model, and inserting quoted price. Vendor should complete the Pricing Pages in their entirety as failure to do so may result in Vendor's bids being disqualified.

The Pricing Page contains a list of the Contract Items and estimated purchase volume. The estimated purchase volume for each item represents the approximate volume of anticipated purchases only. No future use of the contract or any individual item is guaranteed or implied.

REQUEST FOR QUOTATION
RFQ 7014EC03 612 CLASS AIR COMPRESSOR, PORTABLE, ELECTRIC
185 C.F.M.

Notwithstanding the foregoing, the Purchasing Division may correct errors at its discretion. Vendor should type or electronically enter the information into the Pricing Page to prevent errors in evaluation. The Pricing Pages were created as a Microsoft Excel document and vendor can request an electronic copy for bid purposes by sending an email to the following address: Crystal.G.Rink@WV.Gov

- 4.3 Price Escalation:** Vendor may ask for a price increase at contract renewal time. Pass through cost only will be accepted at the discretion of the WV Purchasing Division.

5. ORDERING AND PAYMENT:

- 5.1 Ordering:** Vendor shall accept orders by regular mail, facsimile, e-mail, or any other written forms of communication.
- 5.2 Payment:** Vendor shall accept payment in accordance with the payment procedures of the State of West Virginia.
- 5.3 Equipment Contract Order:** Spending Unit shall issue a written Equipment Contract Order (form number WV-35) for items covered by this contract.

6. DELIVERY AND RETURN:

- 6.1 Delivery Time:** Vendor shall deliver standard orders within 90 working days after orders are received. Vendor shall ship all orders in accordance with the above schedule and shall not hold orders until a minimum delivery quantity is met. A completed pilot model for inspection must be provided within 60 working day(s) after receipt of the purchase agreement by the successful vendor. Working day is defined as any week day, Monday thru Friday, excluding Federal and State Holidays.
- 6.2 Late Delivery:** The Agency placing the order under this Contract must be notified in writing if orders will be delayed for any reason. Any delay in delivery that could cause harm to an Agency will be grounds for cancellation of the delayed order, and/or obtaining the items ordered from a third party.

Any Agency seeking to obtain items from a third party under this provision must first obtain approval of the Purchasing Division.

REQUEST FOR QUOTATION
RFQ 7014EC03 612 CLASS AIR COMPRESSOR, PORTABLE, ELECTRIC
185 C.F.M.

- 6.3 Delivery Payment/Risk of Loss:** Standard order delivery shall be F.O.B. destination to the Agency's location. Vendor shall include the cost of standard order delivery charges in its bid pricing/discount and is not permitted to charge the Agency separately for such delivery.
- 6.4 Representative Unit for Test:** The successful vendor must (if specified) provide the DOH one (1) completed represented unit to be observed and evaluated on each order to insure compliance with specification. If requested, the time period for testing and evaluation shall be seven (7) working days following receipt of the unit. DOH will incur no obligation for deterioration of surfaces, finishes, seals, and mechanical or electrical parts on the unit resulting from operation and testing within the limits of these specifications; nor will DOH incur obligation for damage to the unit resulting from failure to meet specifications when due care and attention is given by DOH and testing is done within the limits of these specifications. Failure of the pilot unit to satisfactorily meet specifications as bid may be cause for cancellation of the purchase order, and return of the delivered unit along with all associated equipment to the vendor at the vendor's expense.
- 6.5 Condition of Unit(s) Upon Delivery:** All units must arrive at the prescribed delivery point having been completely pre-serviced with oil, lubricants, and coolant. All prescribed precautions pertaining to first operations and break-in of the unit are to be posted conspicuously on the unit for ready observance by the operator.
- 6.6 Safety Features:** Units shall be delivered to the WVDOH with a manufacturers recommended safety related decals and safety features intact.
- 6.7 Delivery Point:** Delivery point of the completed representative unit will be the WVDOH, Equipment Division, Rt. 33 and Brushy Fork Road, Buckhannon, WV 26201.

REQUEST FOR QUOTATION
RFQ 7014EC03 612 CLASS AIR COMPRESSOR, PORTABLE, ELECTRIC
185 C.F.M.

7. MISCELLANEOUS:

- 7.1 No Substitutions:** Vendor shall supply only Contract Items submitted in response to the RFQ unless a contract modification is approved in accordance with the provisions contained in this Contract.
- 7.2 Exception to Non-Mandatory Specifications:** Exception to a non-mandatory specification may be made by the bidder, providing the exception is not available from the manufacturer. Any exception must be indicated on a separate attachment and labeled as "Exceptions to Specifications" and supported by documentation from the manufacturer. The state reserves the right to waive minor irregularities in bids or specifications in accordance with §148-1-4(f) of the WV Legislative Rules and Regulations.
- 7.3 Reports:** Vendor shall provide quarterly reports and annual summaries to the Agency showing the Agency's items purchased, quantities of items purchased, and total dollar value of the items purchased. Vendor shall also provide reports, upon request, showing the items purchased during the term of this Contract, the quantity purchased for each of those items, and the total value of purchases for each of those items. Failure to supply such reports may be grounds for cancellation of this Contract.
- 7.4 Contract Manager:** During its performance of this Contract, Vendor must designate and maintain a primary contract manager responsible for overseeing Vendor's responsibilities under this Contract. The Contract manager must be available during normal business hours to address any customer service or other issues related to this Contract. Vendor should list its Contract manager and his or her contact information below.

Contract Manager: Gary Grady
Telephone Number: 304-346-5301
Fax Number: 304-346-5305
Email Address: wvtractor@msn.com

- 7.5 Operating and Service Manuals and Parts Lists:** An operator's manual must be included with each unit upon delivery. A "line sheet" (if applicable) and the "Equipment Preventative Maintenance Questionnaire", (Exhibit "B") must be with pilot unit upon delivery, Attn Marcia Lee. There must be 12 service/shop/maintenance manuals and 14 parts manuals; CD-ROM is preferred in lieu of parts manuals. Manuals shall be delivered upon completion of delivery of total units. Failure to do so will delay payment.

REQUEST FOR QUOTATION
RFQ 7014EC03 612 CLASS AIR COMPRESSOR, PORTABLE, ELECTRIC
185 C.F.M.

27

- 7.6 Training:** Manufacturers and/or dealers will be required to stage a thorough seminar on the subjects of Preventative Maintenance, Operator, and Mechanic Training. In order to keep operators and mechanics updated, the successful vendor shall conduct training sessions covering the operation, maintenance, trouble shooting with each purchase order against this open-end contract. Manufacturers and/or dealers shall be required to furnish the Training Academy with one (1) Operator's Manual to be shipped direct to

WVDOH
Training Academy
P.O. Box 610
Buckhannon, West Virginia 26201

prior to delivery of the pilot unit. Training seminar to be held at the WVDOT, Equipment Division, Buckhannon, WV.

- 7.7 Preventative Maintenance & Operator Procedures:** Manufacturers and/or dealers will be required to submit to the Equipment Division, in addition to the operating and service manuals, booklets and pamphlets explaining the Preventative Maintenance and Operator Procedures to be used by the operators of this equipment, and must include such things as daily prestart inspection procedure, service schedule, and routine maintenance required, safety precautions, etc. The successful vendor shall furnish all training aids; i.e. videos, projectors as required in conducting the training.
- 7.8 Warranty and Service Policy:** The unit must be accompanied upon delivery by the unit's manufacturers executed warranty and service policy.
- 7.9 Unspecified Accessories & Features:** All parts, equipment, accessories, material, design and performance characteristics not specified herein, but which are necessary to provide a complete unit, must be furnished with each unit and required to conform to strength, quality of material, and quality of workmanship to those which are advertised and provided to the market in general by the unit industry. All parts and accessories advertised and regularly supplied as standard shall be included, except those which would represent duplication of these specified and except those which, by specification, are not to be furnished. All standard safety features, required by Federal and State Law, shall be included.

Exhibit A

Cost Sheet

RFQ 7014EC03

Item Number	Estimated Quantity	Unit of Measure	Description	Unit Price	Total
1	12	Each	One complete unit: Air Compressor, portable, electric, 185 C.F.M.	\$23,900.00	\$286,800.00

Vendor should also supply the year, make, and model of the following:

Air Compressor, Portable, Electric, 185 C.F.M. 2014 MMD Airman PDS 185S-6C2 Portable 185 CFM Air compressor

EXHIBIT B

EQUIPMENT PREVENTATIVE MAINTENANCE QUESTIONNAIRE

THIS FORM MUST BE COMPLETED IN ITS ENTIRETY BY SUCCESSFUL BIDDER OR MANUFACTURER'S TECHNICAL REPRESENTATIVE PRIOR TO DELIVERY OF PILOT MODEL TO THE WVDOT.

DESCRIPTION: _____ MAKE: _____

MODEL: _____ YEAR: _____ PURCHASE AMOUNT: _____

ENGINE: MAKE: _____ MODEL: _____ FUEL TYPE: _____

HORSEPOWER: _____ CYLINDER: _____ ENGINE SERIAL: _____

COOLING SYSTEM CAPACITY: _____

BELTS: DESCRIPTION: _____ PART NUMBERS: _____

GVW: _____ AXLE CAPACITY:FRONT: _____ REAR: _____

TIRES: FRONT MAKE & SIZE: _____

REAR MAKE & SIZE: _____

DIMENSIONS OF UNIT: LENGTH: _____ WIDTH: _____ LENGTH: _____

VENDOR CONTACT PERSON: _____ PHONE: _____

PARTS:

BATTERY MAKE: _____ MODEL: _____ CCA: _____

TOP OR SIDE POST: _____ DIMENSIONS: LENGTH _____ WIDTH _____ HEIGHT _____

SPARK PLUGS OR FUEL INJECTORS MAKE: _____ PART # _____

FUEL PUMP OR INJECTION PUMP MAKE: _____ MODEL: _____

ALTERNATOR MAKE: _____ PART #: _____

STARTER MAKE: _____ PART #: _____

TURBO CHARGER MAKE: _____ PART #: _____

TRANS. MAKE: _____ MODEL: _____ AUTO/MANUAL: _____

HYDRAULIC PUMP MAKE: _____ MODEL: _____

FILTERS	MAKE	PART NO.	LUBRICANT	MANUFACTURER TYPE
OIL	_____	_____	ENGINE	_____
AIR INNER	_____	_____	TRANSMISSION	_____
AIR OUTER	_____	_____	POWER STEERING	_____
FUEL PRIMARY	_____	_____	HYDRAULIC	_____
FUEL SECONDARY	_____	_____	DIFFERENTIALS	_____
COOLANT	_____	_____	BRAKE FLUID	_____
HYDRAULIC	_____	_____	COOLANT	_____
OTHER	_____	_____	OTHER	_____



State of West Virginia
 Department of Administration
 Purchasing Division
 2019 Washington Street East
 Post Office Box 50130
 Charleston, WV 25305-0130

WV PURCHASING ACA SECT Fax 304-558-4115
Solicitation

Nov 21 2013 04:53pm P001/004

NUMBER
 7014EC03

PAGE
 1

ADDRESS CORRESPONDENCE TO ATTENTION OF:
 CRYSTAL RINK
 304-558-2306

RFQ COPY

ADDRESS TO

TYPE NAME/ADDRESS HERE

West Virginia Tractor Company
 P.O. Box 473
 Charleston, WV 25322

SHIP TO

DIVISION OF HIGHWAYS
 EQUIPMENT DIVISION
 ROUTE 33
 BRUSHY FORK ROAD
 BUCKHANNON, WV
 26201 304-472-1750

DATE PRINTED:
 11/21/2013

BID OPENING DATE: 12/11/2013

BID OPENING TIME 1:30PM

LINE	QUANTITY	UOP	CAT NO	ITEM NUMBER	UNIT PRICE	AMOUNT
ADDENDUM NO. 01						
THIS ADDENDUM HAS BEEN ISSUED TO MODIFY THE ORIGINAL SOLICITATION PER THE ATTACHED DOCUMENTATION.						
001	1	EA		025-50		
				PROVIDE/AIR COMPRESSOR/PORTABLE/ELECTRIC		
***** THIS IS THE END OF RFQ 7014EC03 ***** TOTAL:						

SIGNATURE: *Raymond* TELEPHONE: 304-346-5301 DATE: 12-6-2013
 TITLE: President FEIN: 550621655 ADDRESS CHANGES TO BE NOTED ABOVE

WHEN RESPONDING TO SOLICITATION, INSERT NAME AND ADDRESS IN SPACE ABOVE LABELLED VENDOR

SOLICITATION NUMBER: 7014EC03
Addendum Number: 1

The purpose of this addendum is to modify the solicitation identified as ("Solicitation") to reflect the change(s) identified and described below.

Applicable Addendum Category:

- | Modify bid opening date and time
- | Modify specifications of product or service being sought
- | Attachment of vendor questions and responses
- | Attachment of pre-bid sign-in sheet
- | Correction of error
- | Other

Description of Modification to Solicitation:

To modify the technical question deadline to November 27, 2013 at 5:00 PM

To remove the must accept purchasing card requirement

Additional Documentation: Documentation related to this Addendum (if any) has been included herewith as Attachment A and is specifically incorporated herein by reference.

Terms and Conditions:

1. All provisions of the Solicitation and other addenda not modified herein shall remain in full force and effect.
2. Vendor should acknowledge receipt of all addenda issued for this Solicitation by completing an Addendum Acknowledgment, a copy of which is included herewith. Failure to acknowledge addenda may result in bid disqualification. The addendum acknowledgement should be submitted with the bid to expedite document processing.

ATTACHMENT A

ADDENDUM ACKNOWLEDGEMENT FORM
SOLICITATION NO.: 7014EC03

Instructions: Please acknowledge receipt of all addenda issued with this solicitation by completing this addendum acknowledgment form. Check the box next to each addendum received and sign below. Failure to acknowledge addenda may result in bid disqualification.

Acknowledgment: I hereby acknowledge receipt of the following addenda and have made the necessary revisions to my proposal, plans and/or specification, etc.

Addendum Numbers Received:

(Check the box next to each addendum received)

- | | |
|--|--|
| <input checked="" type="checkbox"/> Addendum No. 1 | <input type="checkbox"/> Addendum No. 6 |
| <input checked="" type="checkbox"/> Addendum No. 2 | <input type="checkbox"/> Addendum No. 7 |
| <input type="checkbox"/> Addendum No. 3 | <input type="checkbox"/> Addendum No. 8 |
| <input type="checkbox"/> Addendum No. 4 | <input type="checkbox"/> Addendum No. 9 |
| <input type="checkbox"/> Addendum No. 5 | <input type="checkbox"/> Addendum No. 10 |

I understand that failure to confirm the receipt of addenda may be cause for rejection of this bid. I further understand that any verbal representation made or assumed to be made during any oral discussion held between Vendor's representatives and any state personnel is not binding. Only the information issued in writing and added to the specifications by an official addendum is binding.

West Virginia Tractor Company

Company

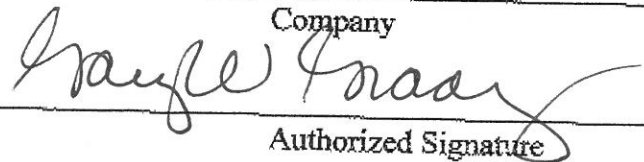

Authorized Signature

12-6-2013

Date

NOTE: This addendum acknowledgment should be submitted with the bid to expedite document processing.
 Revised 6/8/2012



State of West Virginia
 Department of Administration
 Purchasing Division
 2019 Washington Street East
 Post Office Box 50130
 Charleston, WV 25305-0130

Solicitation

NUMBER
7014EC03

PAGE
1

ADDRESS CORRESPONDENCE TO ATTENTION OF:
CRYSTAL RINK 304-558-2306

*709051756 304-346-5301

V
E
N
D
O
R

WV TRACTOR COMPANY
 PO BOX 473
 CHARLESTON WV 25322

S
H
I
P
T
O

DIVISION OF HIGHWAYS
 EQUIPMENT DIVISION
 ROUTE 33
 BRUSHY FORK ROAD
 BUCKHANNON, WV
 26201 304-472-1750

DATE PRINTED
12/03/2013

BID OPENING DATE: 12/11/2013 BID OPENING TIME 1:30PM

LINE	QUANTITY	UOP	CAT NO.	ITEM NUMBER	UNIT PRICE	AMOUNT
ADDENDUM NO. 02						
THIS ADDENDUM HAS BEEN ISSUED TO MODIFY THE ORIGINAL SOLICITATION PER THE ATTACHED DOCUMENTATION.						
0001	1	EA		025-50		
				PROVIDE/AIR COMPRESSOR/PORTABLE/ELECTRIC		
***** THIS IS THE END OF RFQ 7014EC03 ***** TOTAL:						

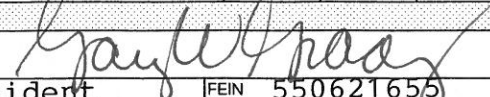
SIGNATURE		TELEPHONE	304-346-5301	DATE	12-6-2013
TITLE	President	FEIN	550621655	ADDRESS CHANGES TO BE NOTED ABOVE	

WHEN RESPONDING TO SOLICITATION, INSERT NAME AND ADDRESS IN SPACE ABOVE LABELED 'VENDOR'

SOLICITATION NUMBER: 7014EC03**Addendum Number:** 2

The purpose of this addendum is to modify the solicitation identified as (“Solicitation”) to reflect the change(s) identified and described below.

Applicable Addendum Category:

- | Modify bid opening date and time
- | Modify specifications of product or service being sought
- | Attachment of vendor questions and responses
- | Attachment of pre-bid sign-in sheet
- | Correction of error
- | Other

Description of Modification to Solicitation:

To provide the answers to vendor technical questions
To provide a copy of the pre-bid meeting sign-in sheet

Additional Documentation: Documentation related to this Addendum (if any) has been included herewith as Attachment A and is specifically incorporated herein by reference.

Terms and Conditions:

1. All provisions of the Solicitation and other addenda not modified herein shall remain in full force and effect.
2. Vendor should acknowledge receipt of all addenda issued for this Solicitation by completing an Addendum Acknowledgment, a copy of which is included herewith. Failure to acknowledge addenda may result in bid disqualification. The addendum acknowledgement should be submitted with the bid to expedite document processing.

ATTACHMENT A

ADDENDUM # 2 FOR PRE-BID**7014EC03****AIR COMPRESSOR, PORTABLE, ELECTRIC 185 C.F.M.**

The original language in contract will be listed first with question and answer to follow below.

1. 3.1.1. Compressor, Air, Portable, Electric, 185 C.F.M.

Question # 1: Will you change definition of this?

Answer: Yes, we will change to read: 3.1.1. Compressor, Air, Portable 185 C.F.M.

2. 3.1.1.3.3 Discharge line shall be fitted with an automatic discharge moisture trap. Size and capacity shall be determined by manufacturer for compressor rating and located between air receiver and service valve.

Question: Which kind do you want? A metal bowl or a polycarbonate bowl with metal guard?:

Answer: You need to bid both bowls

3. 3.1.1.3.4 Shall have two (2) discharge line lubricators – one (1) quart capacity each, to each outlet, fitted and easily accessible.

Question: What type of bowl do you want? Metal bowl or polycarbonate with metal guard?

Answer: You need to bid both bowls

4. 3.1.1.4.

Question: Is this to be a Tier 4 engine?

Answer: Yes, this will be added to read: 3.1.1.4.4 Shall have Tier 4 Engine

5. 3.1.1.4.3 Shall have rain cap to protect engine and muffler.

Question # 1: Our exhaust pipe/muffler has a turn out position so it doesn't face wind during tow. Will this be acceptable?

Answer: Yes

Question # 2: Our standard muffler has holes for water drain. We could add an exhaust cap, but it would be noisy and redundant. Will you accept our standard?

Answer: This is acceptable.

6. 3.1.1.6.2 Engine coolant shall be rated at -32 degrees F.

Question: Will you accept -20 degrees F.?

Answer: Yes

7. 3.1.1.6.3 The solar panel generator array must recharge the battery bank at a rate of 2.5 hours sun to one (1) 24 hour period of usage.

Answer: This was inadvertently put in by mistake. We will delete 3.1.1.6.3

8. 3.1.1.7.2 Ammeter or voltmeter.

Question: With the new Tier IV engine, the gauge package includes a charge light rather than an ammeter or voltmeter. Will you change this?

Answer: Yes, we will change to read 3.1.1.7.2 Charge Light.

9. 3.1.1.8.5 Tires shall be P205/75R15 load range C, highway tread. Must have wheel drop center 7 inches wide.

Question : Ours is P215/75R14 Load Range C, Will this be acceptable?

Answer: Yes this is acceptable

10. 3.1.1.15.6 Must have twin hose reels capable of holding 50 foot x 1 inch outside diameter (O.D.) hose. (Hose supplied by the WV Division of Highways)

Question: Is this to be manual or self retracting? Check inside diameter of Hose, should be $\frac{3}{4}$ inch diameter?

Answer: We will change to read: 3.1.1.15.6 Must have, manual twin hose reels capable of holding 50 foot x $\frac{3}{4}$ " inside diameter (I.D.) hose. (Hose supplied by the WV Division of Highways).

11. **Question:** Is there a particular paint color?

Answer: We will add Section 3.1.1.17 to read as: **3.1.1.17 Paint** – The following are mandatory items related to the paint color.

We will also add 3.1.1.17.1 to read as: 3.1.1.17.1 Manufacturers standard paint color.

12. **6.1 Delivery Time:** Vendor shall deliver standard orders within 90 working days after orders are received.

Question: Can this be changed to 120?

Answer: Yes, this will be changed to read as: Vendor shall deliver standard orders within 120 working days after orders are received.

PRE-BID CONFERENCE
SIGN IN SHEET

Request for Quotation Number:

7014EC03

Date:

11/19/13 12:00 P.M.

Project Description:

Portable/Electric Air Compressor

PLEASE PRINT LEGIBLY. THIS INFORMATION IS ESSENTIAL TO CONTACT THE ATTENDEES IN A TIMELY MANNER. FAILURE TO DO SO MAY RESULT IN DELAYS IN YOUR COMPANY GETTING IMPORTANT BID INFORMATION.

Firm Name:	WV Purchasing Division
Firm Address:	2019 Washington St. East Charleston WV 25305
Representative Attending:	Crystal Pink
Phone Number:	304.558.2402
Fax Number:	304.558.4115
Email Address:	Crystal.G.Pink@wv.gov

Firm Name:	ROPE, INC.
Firm Address:	PO Box 99 FALLING ROCK, WV 25079
Representative Attending:	JOE HOOVER ^{cell} 304-389-7804
Phone Number:	304-548-6701
Fax Number:	304-548-7186
Email Address:	joe@ropeincorporated.com

Firm Name:	MARCIA Lee
Firm Address:	DOH
Representative Attending:	
Phone Number:	
Fax Number:	
Email Address:	

Firm Name:	WVDOH
Firm Address:	
Representative Attending:	Michael J. Neely
Phone Number:	
Fax Number:	
Email Address:	

Firm Name:	QUEST VIRGINIA TRACTOR
Firm Address:	P.O. BOX 473 CHARLESTON WV 25322
Representative Attending:	GARY GRADY
Phone Number:	304-346-5301
Fax Number:	304-346-5305
Email Address:	WV tractor @ usm.com

Firm Name:	WVDOH
Firm Address:	
Representative Attending:	Pam Hall
Phone Number:	Angie Moorman DOH
Fax Number:	
Email Address:	

ADDENDUM ACKNOWLEDGEMENT FORM
SOLICITATION NO.: 7014EC03

Instructions: Please acknowledge receipt of all addenda issued with this solicitation by completing this addendum acknowledgment form. Check the box next to each addendum received and sign below. Failure to acknowledge addenda may result in bid disqualification.

Acknowledgment: I hereby acknowledge receipt of the following addenda and have made the necessary revisions to my proposal, plans and/or specification, etc.

Addendum Numbers Received:

(Check the box next to each addendum received)

- | | |
|--|--|
| <input checked="" type="checkbox"/> Addendum No. 1 | <input type="checkbox"/> Addendum No. 6 |
| <input checked="" type="checkbox"/> Addendum No. 2 | <input type="checkbox"/> Addendum No. 7 |
| <input type="checkbox"/> Addendum No. 3 | <input type="checkbox"/> Addendum No. 8 |
| <input type="checkbox"/> Addendum No. 4 | <input type="checkbox"/> Addendum No. 9 |
| <input type="checkbox"/> Addendum No. 5 | <input type="checkbox"/> Addendum No. 10 |

I understand that failure to confirm the receipt of addenda may be cause for rejection of this bid. I further understand that any verbal representation made or assumed to be made during any oral discussion held between Vendor's representatives and any state personnel is not binding. Only the information issued in writing and added to the specifications by an official addendum is binding.

West Virginia Tractor Company

Company

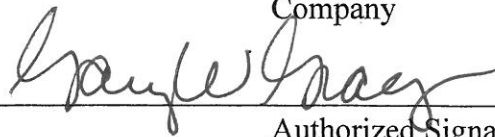

Authorized Signature

12-6-2013

Date



MMD
EQUIPMENT

AIR COMPRESSORS

PDS 185S-6C2



- Simply the best 185 compressor anywhere!
- Equipped with a Yanmar 45 HP engine.
- Airman Compressors by MMD Equipment are designed to be Super-quiet, Super-efficient, and Super-profitable.
- AIRMAN Screw Air Compressors utilize large diameter air screws that produce more air at lower RPM's, thereby reducing wear and offering the best fuel economy of any air compressor in its class.
- Can be used anywhere, anytime, as the ultra quiet design results in a noise level as low as 62 dBA at 23 feet when idling.
- Diagnostic Panel monitors fuel level, battery, fuel filter, engine air filter, water temperature, compressor air filter, oil pressure, discharge air temperature and auto idle.
- Rear Service Valves & Gauges are located on the rear of the machine and display the tachometer reading, fuel gauge and hours of operation.
- Manually operated compressor oil and fuel drains (no tools necessary).
- External oil/separator filters and cartridge-type fuel filter reduce service time and cost.
- Drains for the receiver oil, engine oil and fuel drain simplify maintenance.
- LED Tail Lights increase visibility and long-term reliability.
- Trailer is made of powder-coated, ¼" steel to insure unparalleled value and utility.
- Standard 2 year or 2,000 hour warranty, extendable up to 5 years or 5,000 hours with use of MMD authorized oil and filters.

AIRMAN Engineered. Durable. Reliable. Quality.

3 HAWK COURT • SWEDESBORO, NJ 08085

Voice: 800.433.1382 Facsimile: 800.225.5579 www.mmdequipment.com

7700 DENSMORE AVENUE • VAN NUYS, CA 91406



SALES: 1.800.433.1382

SERVICE SUPPORT: 1.800.869.0321

PARTS: 1.800.257-7859

PRODUCTS

SALES NETWORK

PARTS & SERVICE NETWORK

DOWNLOADS

ABOUT US

AIR COMPRESSORS

Airman Compressors

Features

PowerPro Generators

Thermobile Heaters

Lynxrite Trailers

Credit Applications

AIRMAN SCREW AIR COMPRESSORS — THE ULTIMATE IN RELIABILITY.

Thick, reinforced castings deliver increased strength, increased dimensional stability in sealing areas, and better support to the bearings and rotors. Airman's heavier castings evenly transfer heat away from the bearings and rotors to reduce internal thermal stresses.

One-way valve automatically controls air entry into the compressor based on demand sensed by the pressure regulator.

Fiber gear coupler delivers quiet operation, is maintenance free, and allows easy removal of either the engine or air end. The coupling will not deteriorate due to vibration, heat or length of service.

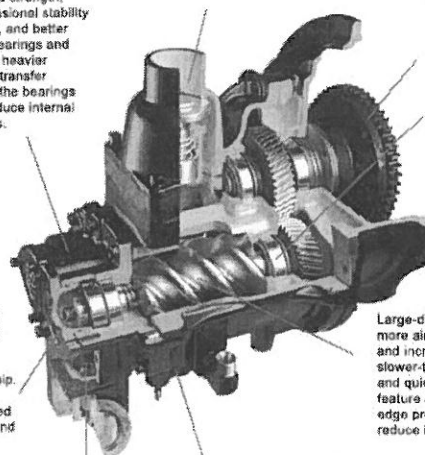

Oversized bearings combine to give solid support during transfer of power from the gear train to the rotors. This ensures excellent reliability and extended service life.

Double oversized bearings hold the positions of the two rotors in a precise relationship. Bearings are pressure lubricated for both cooling and long service life.

Large-diameter air screws produce more air at lower RPMs, reducing wear and increasing fuel efficiency. Also, slower-turning screws mean less noise and quieter operation. Airman screws feature a patented SmoothSeal™ rotor edge profile to eliminate blow-by and reduce internal friction.

Check valve eliminates backflow and allows multiple compressors to safely feed a common pressure tank in high-volume installations.

The pressurized oiling system continuously lubricates and cools the mechanical components including rotors, gears and bearings. Airman's AI-seasons™ oil is specially formulated to provide unmatched compressor reliability and service life.

NISSAN DIESEL POWER — A BREAKTHROUGH IN PERFORMANCE.

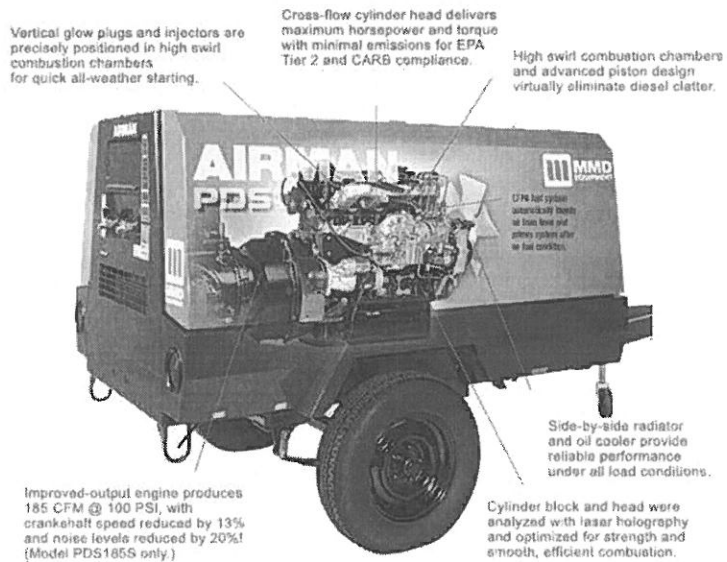

5-YEAR WARRANTY
 DAY-IN/DAY-OUT DEPENDABILITY.
 THE RELIABILITY OF THE AIRMAN AIR COMPRESSORS ARE PROVEN IN THOUSANDS OF APPLICATIONS WORLDWIDE AND BACKED BY A STANDARD WITH A 5 YEAR OR 5,000 HOUR ENGINE WARRANTY AND A STANDARD 2 YEAR AIR-END AND COUPLER WARRANTY THAT IS EXTENDABLE TO 5 YEARS WITH THE USE OF AIRMAN OIL AND FILTERS. IN ADDITION, YOU'LL BE SUPPORTED BY MMD EQUIPMENT - YOUR PARTNER IN SUCCESS. (SEE COMPLETE WARRANTY FOR DETAILS)

[MMD Airman Compressors](#) [MMD PowerPro Generators](#) [MMD Thermobile Heaters](#) [LynxRite Trailers](#)
[Home](#) [Sales](#) [Tech Support](#) [Downloads](#) [Press](#) [About Us](#)
[Sitemap](#) [Legal](#) [Privacy](#) [Terms & Conditions](#)

© 2012 Copyright Rajysan Inc, MMD Equipment, Airman, PowerPro, Thermobile, Lynxrite Trailers. All rights reserved.

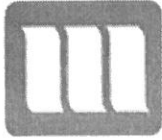

SALES: 1.800.433.1382

SERVICE SUPPORT: 1.800.869.0321

PARTS: 1.800.257-7859

PRODUCTS SALES NETWORK PARTS & SERVICE NETWORK DOWNLOADS ABOUT US

AIR COMPRESSORS

Airman Compressors

Features

PowerPro Generators

Thermobile Heaters

Lynxrite Trailers

Credit Applications

AIR COMPRESSORS

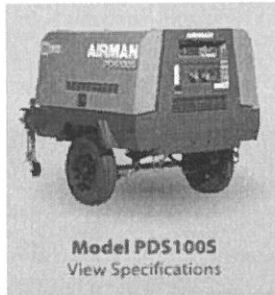

Model PDS100S
View Specifications

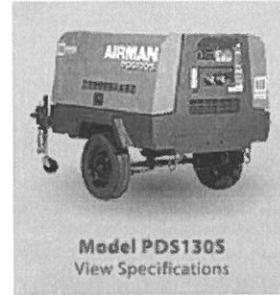

Model PDS130S
View Specifications

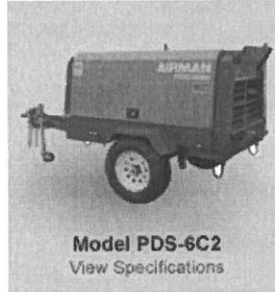

Model PDS-6C2
View Specifications

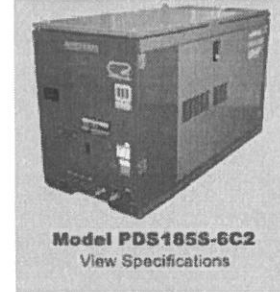

Model PDS185S-6C2
View Specifications

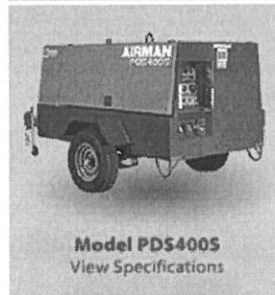

Model PDS400S
View Specifications

QUIET, EFFICIENT, AND PROFITABLE.

When it comes to efficiency and dependability, MMD Equipment's ultra-quiet air compressors are designed for today's demands. They're extremely reliable — which helps reduce downtime and maintenance as well as increasing your profitability. Just as important, our superior designs meet environmental concerns and are fuel-efficient, light and well-balanced.

QUIET, HIGH-EFFICIENCY DESIGN

Engine idles as low as 1,300 RPM - less than half the speed of competitive models - to increase fuel economy and reduce component wear.

Noise level is as low as 63dBA at 7 meters when idling. This is substantially less noise than competitor's machine.

Direct-injection engine meets strict new EPA Tier 2 emission standards.

CONVENIENT ACCESS AND STORAGE

Gull-wing style doors allow easy one-hand operation! Large, lockable doors with gas struts virtually lift themselves

COMPRESSORS

	PDS100S	PDS130S	PDS185S - 6C2	PDS185S - 5C2	PDS400S
Type	Rotary Twin-Screw, Single-Stage	Rotary Twin-Screw, Single-Stage	Rotary Twin-Screw, Single-Stage	Rotary Twin-Screw, Single-Stage	Rotary Twin-Screw, Single-Stage
Free Air Delivery	100 cfm	130 cfm	185 cfm	175 cfm	400 cfm
Working Pressure	100 psi	100 psi	100 psi	100 psi	100 psi
Max.	120 psi	120 psi	120 psi	120 psi	120 psi

for easy access to tool storage and service components.

NEW larger tool compartments hold 90-lb. breakers, various tools and hoses. Optional factory-installed hose reels (50' and 100') are available for self-storing air hose.

ELECTRIC FUEL PRIMER AND AIR-BLEED (EFPA) PUMP

Automatically primes and bleeds the air from the system without opening injector lines if the compressor runs out of fuel.

Reduces downtime and service calls.

EASIER, FASTER SERVICE AND MAINTENANCE

Engine oil and water drain to the outside of the machine.

Hand-operated compressor oil and fuel drains (no tools required).

New external oil/air separator filter and cartridge-type fuel filter reduce service time and cost.

Side-by-side radiator and oil cooler are more efficient and easier to clean.

DURABLE, RELIABLE CONSTRUCTION

Powder-coated finish and stainless steel hardware maintain their attractive appearance.

Engine is directly coupled to the air-end by a fiber gear coupler for improved power transmission.

Improved unloader valve and air pressure regulator feature O-rings instead of a diaphragm.

Working Pressure					
Air Receiver Tank	7.92 gal	7.92 gal	5.56 gal	5.56 gal	25.88 gal
Air Outlets	3/4" x 2	3/4" x 2	3/4" x 2	3/4" x 2	3/4" x 2 plus
Engine Coupling Type	Fiber Gear Direct Coupling	Fiber Gear Direct Coupling	Fiber Gear Direct Coupling	Fiber Gear Direct Coupling	Rubber Coupling 1" 1/4 x 1"
Lubrication System Type	Forced by Compressed Air	Forced by Compressed Air	Forced by Compressed Air	Forced by Compressed Air	Forced by Compressed Air
Lubrication System Capacity	3.7 gal	3.7 gal	4.0 gal	4.0 gal	13.74 gal
Oil Cooler Type	Separate Side-by-Side Oil Cooler and Radiator	Separate Side-by-Side Oil Cooler and Radiator	Separate Side-by-Side Oil Cooler and Radiator	Separate Side-by-Side Oil Cooler and Radiator	Separate Side-by-Side Oil Cooler and Radiator
Separator	External	External	External	External	Internal

DIESEL ENGINE

	PDS100S	PDS130S	PDS185S - 6C2	PDS185S - 5C2	PDS400S
Model	Shibaura S773L-C	Shibaura N843L-C	Yanmar 4TNV88-B	Yanmar 4TNV88-B	Isuzu 4JJ1X
Type	Inline, Water-Cooled, Direct-Injected, Tier 2 Compliant	Inline, Water-Cooled, 4-Stroke, High-Swirl, Direct-Injected, Tier 2 Compliant	Interim Tier 4	Interim Tier 4	Inline, Water-Cooled, Direct-Injected, Tier 3 Compliant, Inter-cooler
Cylinders	3	3	4	4	4
Displacement	69 cu in (1.130 L)	101.4 cu in (1.661 L)	133.6 cu in (2.189 L)	133.6 cu in (2.189 L)	183 cu in (2.999 L)
Horsepower	27.1 hp	37.5 hp	46.8 hp (34.9 kw)	45 hp (33.5 kw)	113.2 hp (84.4 kw)
Max Torque	44.1 ft-lb/2,000 rpm	73.5 ft-lb/2,200 rpm	49.5 hp (36.4 kw)	48.8 hp (36.4 kw)	126.1 hp (94.0 kw)
Low Idle	1,950 rpm	1,600 rpm	1,300 rpm	1,300 rpm	1,300 rpm
High Idle	3,500 rpm	3,000 rpm	3,000 rpm	3,000 rpm	2,200 rpm
Fuel Consumption	1.6 gph @ Full Load, 1.2 gph @ 70% Load, 0.7 gph @ No Load	2.0 gph @ Full Load, 1.5 gph @ 70% Load, 0.8 gph @ No Load	2.4 gph @ 100% Full Load, 1.6 gph @ 70% Load, 0.65 gph @ No Load (with Auto-Idle)	2.4 gph @ 100% Full Load, 1.6 gph @ 70% Load, 0.65 gph @ No Load (with Auto-Idle)	5.3 gph @ 100% Full Load, 4.1 gph @ 70% Load, 2.0 gph @ No Load (with Auto-Idle)
Fuel	18.5 gal	18.5 gal	24 gal	25 gal	47.02 gal

Capacity					
Cooling System Capacity	1.2 gal	1.72 gal	1.5 gal	2.5 gal	2.90 gal
Oil Capacity	1.3 gal	1.59 gal	2 gal	2 gal	3.96 gal
Electrical System	12-Volt, Maintenance-Free Battery	12-Volt, Maintenance-Free Battery	12-Volt, Maintenance-Free Battery	12-Volt, Maintenance-Free Battery	24-Volt, Maintenance-Free Battery

WEIGHTS AND DIMENSIONS

	PDS100S	PDS130S	PDS185S - 6C2	PDS185S - 5C2	PDS400S
Dry Weight	1,742 lbs	1,676 lbs	1,962 lbs (890 kgs) - no fuel	1,653 lbs (750 kgs) - no fuel	3,550 lbs
Weight with Towing Frame	1,956 lbs	2,072 lbs	1,962 lbs	N/A	3,975 lbs
Weight w/o Towing Frame	1,724 lbs	1,852 lbs	1,896 lbs	1,653 lbs.	3,550 lbs
Length with Towing Frame	116 in	116 in	128.7 in (3,217.5 mm)	N/A	157 in
Length w/o Towing Frame	62 in	62 in	74 in	78.7 in (2,000 mm)	105.5 in
Overall Width	57 in	57 in	66.9 in (1,700 mm)	33 in	57.26 in
Height with Towing Frame	57 in	57 in	59.8 in	N/A	64 in
Height w/o Towing Frame	39 in	39 in	38 in	45.3 in (1,150 mm)	47.63 in
Operating Weight			2,183 lbs.	1,896 lbs.	4,012 lbs.

OPERATING PARAMETERS

	PDS100S	PDS130S	PDS185S - 6C2	PDS185S - 5C2	PDS400S
Max Altitude	4,921 ft	4,921 ft	4,921 ft (1,500 meters)	4,921 ft (1,500 meters)	4,921 ft (1,500 meters)
Max Ambient Temperature	113 degrees F	113 degrees F	104 degrees F (40 degrees C)	their att ractive app	113 degrees F
Min Ambient Temperature	-5 degrees F	5 degrees F	5 degrees F (-15 degrees C)	5 degrees F (-15 degrees C)	5 degrees F (-15 degrees C)
Max Incline	15 degrees	15 degrees	15 degrees	15 degrees	15 degrees
Sound Level	68 dBA	68 dBA	62 dBA @ 23 ft when idling	69 dBA @ 23 ft when idling	73.6 dBA

AIRMAN WARRANTY TERM - The complete machine within 1 year of the original

purchase date. The air-end within 2 years from the original purchase date. (A 5-year air-end warranty is available based on exclusive use of Airman Oil and filters). Internal parts of the Isuzu, Nissan or Shibaura engine within 5 years of the original purchase date or 5,000 hours whichever occurs first.

[MMD Airman Compressors](#) [MMD PowerPro Generators](#) [MMD Thermobile Heaters](#) [LynxRite Trailers](#)

[Home](#) [Sales](#) [Tech Support](#) [Downloads](#) [Press](#) [About Us](#)

[Sitemap](#) [Legal](#) [Privacy](#) [Terms & Conditions](#)

© 2012 Copyright Rajysan Inc. MMD Equipment, Airman, PowerPro, Thermobile, Lynxrite Trailers. All rights reserved.

State of West Virginia

VENDOR PREFERENCE CERTIFICATE

Certification and application* is hereby made for Preference in accordance with West Virginia Code, §5A-3-37. (Does not apply to construction contracts). West Virginia Code, §5A-3-37, provides an opportunity for qualifying vendors to request (at the time of bid) preference for their residency status. Such preference is an evaluation method only and will be applied only to the cost bid in accordance with the West Virginia Code. This certificate for application is to be used to request such preference. The Purchasing Division will make the determination of the Resident Vendor Preference, if applicable.

- 1. Application is made for 2.5% resident vendor preference for the reason checked: Bidder is an individual resident vendor and has resided continuously in West Virginia for four (4) years immediately preceding the date of this certification; or, [x] Bidder is a partnership, association or corporation resident vendor and has maintained its headquarters or principal place of business continuously in West Virginia for four (4) years immediately preceding the date of this certification; or 80% of the ownership interest of Bidder is held by another individual, partnership, association or corporation resident vendor who has maintained its headquarters or principal place of business continuously in West Virginia for four (4) years immediately preceding the date of this certification; or, Bidder is a nonresident vendor which has an affiliate or subsidiary which employs a minimum of one hundred state residents and which has maintained its headquarters or principal place of business within West Virginia continuously for the four (4) years immediately preceding the date of this certification; or,
2. Application is made for 2.5% resident vendor preference for the reason checked: [x] Bidder is a resident vendor who certifies that, during the life of the contract, on average at least 75% of the employees working on the project being bid are residents of West Virginia who have resided in the state continuously for the two years immediately preceding submission of this bid; or,
3. Application is made for 2.5% resident vendor preference for the reason checked: Bidder is a nonresident vendor employing a minimum of one hundred state residents or is a nonresident vendor with an affiliate or subsidiary which maintains its headquarters or principal place of business within West Virginia employing a minimum of one hundred state residents who certifies that, during the life of the contract, on average at least 75% of the employees or Bidder's affiliate's or subsidiary's employees are residents of West Virginia who have resided in the state continuously for the two years immediately preceding submission of this bid; or,
4. Application is made for 5% resident vendor preference for the reason checked: [x] Bidder meets either the requirement of both subdivisions (1) and (2) or subdivision (1) and (3) as stated above; or,
5. Application is made for 3.5% resident vendor preference who is a veteran for the reason checked: Bidder is an individual resident vendor who is a veteran of the United States armed forces, the reserves or the National Guard and has resided in West Virginia continuously for the four years immediately preceding the date on which the bid is submitted; or,
6. Application is made for 3.5% resident vendor preference who is a veteran for the reason checked: Bidder is a resident vendor who is a veteran of the United States armed forces, the reserves or the National Guard, if, for purposes of producing or distributing the commodities or completing the project which is the subject of the vendor's bid and continuously over the entire term of the project, on average at least seventy-five percent of the vendor's employees are residents of West Virginia who have resided in the state continuously for the two immediately preceding years.

Bidder understands if the Secretary of Revenue determines that a Bidder receiving preference has failed to continue to meet the requirements for such preference, the Secretary may order the Director of Purchasing to: (a) reject the bid; or (b) assess a penalty against such Bidder in an amount not to exceed 5% of the bid amount and that such penalty will be paid to the contracting agency or deducted from any unpaid balance on the contract or purchase order.

By submission of this certificate, Bidder agrees to disclose any reasonably requested information to the Purchasing Division and authorizes the Department of Revenue to disclose to the Director of Purchasing appropriate information verifying that Bidder has paid the required business taxes, provided that such information does not contain the amounts of taxes paid nor any other information deemed by the Tax Commissioner to be confidential.

Under penalty of law for false swearing (West Virginia Code, §61-5-3), Bidder hereby certifies that this certificate is true and accurate in all respects; and that if a contract is issued to Bidder and if anything contained within this certificate changes during the term of the contract, Bidder will notify the Purchasing Division in writing immediately.

West Virginia Tractor Company Bidder:

Signed: [Signature] Title: President

Date: 12-6-2013

*Check any combination of preference consideration(s) indicated above, which you are entitled to receive.

STATE OF WEST VIRGINIA
Purchasing Division

PURCHASING AFFIDAVIT

MANDATE: Under W. Va. Code §5A-3-10a, no contract or renewal of any contract may be awarded by the state or any of its political subdivisions to any vendor or prospective vendor when the vendor or prospective vendor or a related party to the vendor or prospective vendor is a debtor and: (1) the debt owed is an amount greater than one thousand dollars in the aggregate; or (2) the debtor is in employer default.

EXCEPTION: The prohibition listed above does not apply where a vendor has contested any tax administered pursuant to chapter eleven of the W. Va. Code, workers' compensation premium, permit fee or environmental fee or assessment and the matter has not become final or where the vendor has entered into a payment plan or agreement and the vendor is not in default of any of the provisions of such plan or agreement.

DEFINITIONS:

"Debt" means any assessment, premium, penalty, fine, tax or other amount of money owed to the state or any of its political subdivisions because of a judgment, fine, permit violation, license assessment, defaulted workers' compensation premium, penalty or other assessment presently delinquent or due and required to be paid to the state or any of its political subdivisions, including any interest or additional penalties accrued thereon.

"Employer default" means having an outstanding balance or liability to the old fund or to the uninsured employers' fund or being in policy default, as defined in W. Va. Code § 23-2c-2, failure to maintain mandatory workers' compensation coverage, or failure to fully meet its obligations as a workers' compensation self-insured employer. An employer is not in employer default if it has entered into a repayment agreement with the Insurance Commissioner and remains in compliance with the obligations under the repayment agreement.

"Related party" means a party, whether an individual, corporation, partnership, association, limited liability company or any other form or business association or other entity whatsoever, related to any vendor by blood, marriage, ownership or contract through which the party has a relationship of ownership or other interest with the vendor so that the party will actually or by effect receive or control a portion of the benefit, profit or other consideration from performance of a vendor contract with the party receiving an amount that meets or exceeds five percent of the total contract amount.

AFFIRMATION: By signing this form, the vendor's authorized signer affirms and acknowledges under penalty of law for false swearing (W. Va. Code §61-5-3) that neither vendor nor any related party owe a debt as defined above and that neither vendor nor any related party are in employer default as defined above, unless the debt or employer default is permitted under the exception above.

WITNESS THE FOLLOWING SIGNATURE:

Vendor's Name: West Virginia Tractor Company

Authorized Signature: [Signature] Date: 12-6-2013

State of West Virginia

County of Kanawha, to-wit:

Taken, subscribed, and sworn to before me this 6 day of December, 2013.

My Commission expires August 12, 2022.

AFFIX SEAL HERE

NOTARY PUBLIC [Signature]

Purchasing Affidavit (Revised 07/01/2012)

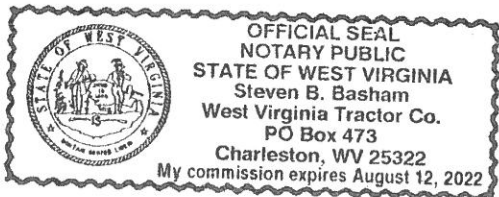

NOTE:

Vendor and Notary's date must be the same.

Notary required to AFFIX SEAL on Purchasing Affidavit.