



State of West Virginia
 Department of Administration
 Purchasing Division
 2019 Washington Street East
 Post Office Box 50130
 Charleston, WV 25305-0130

Solicitation

NUMBER
70135014

PAGE
1

ADDRESS CORRESPONDENCE TO ATTENTION OF
ALAN CUMMINGS 304-558-2402

RFQ COPY
 *111140344 (304) 254-7827
 Heritage Equipment Inc. Inc.
 322 Dry Hill Road
 Beckley, WV 25801

VENDOR

SPECIAL TO

DIVISION OF HIGHWAYS
 EQUIPMENT DIVISION
 ROUTE 33
 BRUSHY FORK ROAD
 BUCKHANNON, WV
 26201 304-472-1750

DATE PRINTED
06/06/2013

BID OPENING DATE: 07/03/2013 BID OPENING TIME 1:30PM

LINE	QUANTITY	UOP	CAT NO	ITEM NUMBER	UNIT PRICE	AMOUNT
0001	1	EA		070-93		see page 34
CAB AND CHASSIS FREIGHTLINER 114SD OR EQUAL						
REQUEST FOR QUOTATION						
THE WEST VIRGINIA STATE PURCHASING DIVISION FOR THE AGENCY, THE WEST VIRGINIA DIVISION OF HIGHWAYS, IS SOLICITING BIDS TO PROVIDE THE AGENCY WITH THE ONE TIME PURCHASE OF A CAB AND CHASSIS, FREIGHTLINER 114SD OR EQUAL, PER THE ATTACHED SPECIFICATIONS.						
***** THIS IS THE END OF RFQ 70135014 ***** TOTAL:						
07/03/13 11:48:22 AM West Virginia Purchasing Division						

SIGNATURE	TELEPHONE	DATE
<i>Paul Hubbard, VP</i>	304-254-7827	7-3-13
TITLE	FEIN	ADDRESS CHANGES TO BE NOTED ABOVE
Sales Manager	550759079	

WHEN RESPONDING TO SOLICITATION, INSERT NAME AND ADDRESS IN SPACE ABOVE LABELED 'VENDOR'

INSTRUCTIONS TO VENDORS SUBMITTING BIDS

1. **REVIEW DOCUMENTS THOROUGHLY:** The attached documents contain a solicitation for bids. Please read these instructions and all documents attached in their entirety. These instructions provide critical information about requirements that if overlooked could lead to disqualification of a Vendor's bid. All bids must be submitted in accordance with the provisions contained in these instructions and the Solicitation. Failure to do so may result in disqualification of Vendor's bid.
2. **MANDATORY TERMS:** The Solicitation may contain mandatory provisions identified by the use of the words "must," "will," and "shall." Failure to comply with a mandatory term in the Solicitation will result in bid disqualification.
3. **PREBID MEETING:** The item identified below shall apply to this Solicitation.

A pre-bid meeting will not be held prior to bid opening.

A **NON-MANDATORY PRE-BID** meeting will be held at the following place and time:

--

A **MANDATORY PRE-BID** meeting will be held at the following place and time:

--

All Vendors submitting a bid must attend the mandatory pre-bid meeting. Failure to attend the mandatory pre-bid meeting shall result in disqualification of the Vendor's bid. No one person attending the pre-bid meeting may represent more than one Vendor.

An attendance sheet provided at the pre-bid meeting shall serve as the official document verifying attendance. The State will not accept any other form of proof or documentation to verify attendance. Any person attending the pre-bid meeting on behalf of a Vendor must list on the attendance sheet his or her name and the name of the Vendor he or she is representing. Additionally, the person attending the pre-bid meeting should include the Vendor's E-Mail address, phone number, and Fax number on the attendance sheet. It is the Vendor's responsibility to locate the attendance sheet and provide the required

information. Failure to complete the attendance sheet as required may result in disqualification of Vendor's bid.

All Vendors should arrive prior to the starting time for the pre-bid. Vendors who arrive after the starting time but prior to the end of the pre-bid will be permitted to sign in, but are charged with knowing all matters discussed at the pre-bid.

Questions submitted at least five business days prior to a scheduled pre-bid will be discussed at the pre-bid meeting if possible. Any discussions or answers to questions at the pre-bid meeting are preliminary in nature and are non-binding. Official and binding answers to questions will be published in a written addendum to the Solicitation prior to bid opening.

4. **VENDOR QUESTION DEADLINE:** Vendors may submit questions relating to this Solicitation to the Purchasing Division. Questions must be submitted in writing. All questions must be submitted on or before the date listed below and to the address listed below in order to be considered. A written response will be published in a Solicitation addendum if a response is possible and appropriate. Non-written discussions, conversations, or questions and answers regarding this Solicitation are preliminary in nature and are non-binding.

Question Submission Deadline: 06/25/2013

Submit Questions to:

Alan Cummings

2019 Washington Street, East

P.O. Box 50130

Charleston, WV 25305

Fax: 304-558-3970

Email: Alan.W.Cummings@WV.Gov

5. **VERBAL COMMUNICATION:** Any verbal communication between the Vendor and any State personnel is not binding, including that made at the mandatory pre-bid conference. Only information issued in writing and added to the Solicitation by an official written addendum by the Purchasing Division is binding.
6. **BID SUBMISSION:** All bids must be signed and delivered by the Vendor to the Purchasing Division at the address listed below on or before the date and time of the bid opening. Any bid received by the Purchasing Division staff is considered to be in the possession of the Purchasing Division and will not be returned for any reason. The bid delivery address is:

Department of Administration, Purchasing Division
2019 Washington Street East
P.O. Box 50130,
Charleston, WV 25305-0130

The bid should contain the information listed below on the face of the envelope or the bid may not be considered:

SEALED BID

BUYER: _____
SOLICITATION NO.: _____
BID OPENING DATE: _____
BID OPENING TIME: _____
FAX NUMBER: _____

In the event that Vendor is responding to a request for proposal, the Vendor shall submit one original technical and one original cost proposal plus n/a convenience copies of each to the Purchasing Division at the address shown above. Additionally, the Vendor should identify the bid type as either a technical or cost proposal on the face of each bid envelope submitted in response to a request for proposal as follows:

BID TYPE: Technical
 Cost

- 7. **BID OPENING:** Bids submitted in response to this Solicitation will be opened at the location identified below on the date and time listed below. Delivery of a bid after the bid opening date and time will result in bid disqualification. For purposes of this Solicitation, a bid is considered delivered when time stamped by the official Purchasing Division time clock.

Bid Opening Date and Time:

07/03/2013 - 1:30 P.M.

Bid Opening Location:

Department of Administration, Purchasing Division
2019 Washington Street East
P.O. Box 50130,
Charleston, WV 25305-0130

- 8. **ADDENDUM ACKNOWLEDGEMENT:** Changes or revisions to this Solicitation will be made by an official written addendum issued by the Purchasing Division. Vendor should acknowledge receipt of all addenda issued with this Solicitation by completing an Addendum Acknowledgment Form, a copy of which is included herewith. Failure to acknowledge addenda may result in bid disqualification. The addendum acknowledgement should be submitted with the bid to expedite document processing.
- 9. **BID FORMATTING:** Vendor should type or electronically enter the information onto its bid to prevent errors in the evaluation. Failure to type or electronically enter the information may result in bid disqualification.

GENERAL TERMS AND CONDITIONS:

1. **CONTRACTUAL AGREEMENT:** Issuance of a Purchase Order signed by the Purchasing Division Director, or his designee, and approved as to form by the Attorney General's office constitutes acceptance of this Contract made by and between the State of West Virginia and the Vendor. Vendor's signature on its bid signifies Vendor's agreement to be bound by and accept the terms and conditions contained in this Contract.

2. **DEFINITIONS:** As used in this Solicitation / Contract, the following terms shall have the meanings attributed to them below. Additional definitions may be found in the specifications included with this Solicitation / Contract.
 - 2.1 "Agency" or "Agencies" means the agency, board, commission, or other entity of the State of West Virginia that is identified on the first page of the Solicitation or any other public entity seeking to procure goods or services under this Contract.

 - 2.2 "Contract" means the binding agreement that is entered into between the State and the Vendor to provide the goods and services requested in the Solicitation.

 - 2.3 "Director" means the Director of the West Virginia Department of Administration, Purchasing Division.

 - 2.4 "Purchasing Division" means the West Virginia Department of Administration, Purchasing Division.

 - 2.5 "Purchase Order" means the document signed by the Agency and the Purchasing Division, and approved as to form by the Attorney General, that identifies the Vendor as the successful bidder and Contract holder.

 - 2.6 "Solicitation" means the official solicitation published by the Purchasing Division and identified by number on the first page thereof.

 - 2.7 "State" means the State of West Virginia and/or any of its agencies, commissions, boards, etc. as context requires.

 - 2.8 "Vendor" or "Vendors" means any entity submitting a bid in response to the Solicitation, the entity that has been selected as the lowest responsible bidder, or the entity that has been awarded the Contract as context requires.

3. **CONTRACT TERM; RENEWAL; EXTENSION:** The term of this Contract shall be determined in accordance with the category that has been identified as applicable to this Contract below:

Term Contract

Initial Contract Term: This Contract becomes effective on

and extends for a period of _____ year(s).

Renewal Term: This Contract may be renewed upon the mutual written consent of the Agency, and the Vendor, with approval of the Purchasing Division and the Attorney General's office (Attorney General approval is as to form only). Any request for renewal must be submitted to the Purchasing Division Director thirty (30) days prior to the expiration date of the initial contract term or appropriate renewal term. A Contract renewal shall be in accordance with the terms and conditions of the original contract. Renewal of this Contract is limited to _____ successive one (1) year periods. Automatic renewal of this Contract is prohibited. Notwithstanding the foregoing, Purchasing Division approval is not required on agency delegated or exempt purchases. Attorney General approval may be required for vendor terms and conditions.

Reasonable Time Extension: At the sole discretion of the Purchasing Division Director, and with approval from the Attorney General's office (Attorney General approval is as to form only), this Contract may be extended for a reasonable time after the initial Contract term or after any renewal term as may be necessary to obtain a new contract or renew this Contract. Any reasonable time extension shall not exceed twelve (12) months. Vendor may avoid a reasonable time extension by providing the Purchasing Division Director with written notice of Vendor's desire to terminate this Contract 30 days prior to the expiration of the then current term. During any reasonable time extension period, the Vendor may terminate this Contract for any reason upon giving the Purchasing Division Director 30 days written notice. Automatic extension of this Contract is prohibited. Notwithstanding the foregoing, Purchasing Division approval is not required on agency delegated or exempt purchases, but Attorney General approval may be required.

- Fixed Period Contract:** This Contract becomes effective upon Vendor's receipt of the notice to proceed and must be completed within 120 working days.
- One Time Purchase:** The term of this Contract shall run from the issuance of the Purchase Order until all of the goods contracted for have been delivered, but in no event shall this Contract extend for more than one fiscal year.
- Other:** See attached.

4. **NOTICE TO PROCEED:** Vendor shall begin performance of this Contract immediately upon receiving notice to proceed unless otherwise instructed by the Agency. Unless otherwise specified, the fully executed Purchase Order will be considered notice to proceed
5. **QUANTITIES:** The quantities required under this Contract shall be determined in accordance with the category that has been identified as applicable to this Contract below.
- Open End Contract:** Quantities listed in this Solicitation are approximations only, based on estimates supplied by the Agency. It is understood and agreed that the Contract shall cover the quantities actually ordered for delivery during the term of the Contract, whether more or less than the quantities shown.
- Service:** The scope of the service to be provided will be more clearly defined in the specifications included herewith.
- Combined Service and Goods:** The scope of the service and deliverable goods to be provided will be more clearly defined in the specifications included herewith.
- One Time Purchase:** This Contract is for the purchase of a set quantity of goods that are identified in the specifications included herewith. Once those items have been delivered, no additional goods may be procured under this Contract without an appropriate change order approved by the Vendor, Agency, Purchasing Division, and Attorney General's office.
6. **PRICING:** The pricing set forth herein is firm for the life of the Contract, unless specified elsewhere within this Solicitation/Contract by the State. A Vendor's inclusion of price adjustment provisions in its bid, without an express authorization from the State in the Solicitation to do so, may result in bid disqualification.
7. **EMERGENCY PURCHASES:** The Purchasing Division Director may authorize the Agency to purchase goods or services in the open market that Vendor would otherwise provide under this Contract if those goods or services are for immediate or expedited delivery in an emergency. Emergencies shall include, but are not limited to, delays in transportation or an unanticipated increase in the volume of work. An emergency purchase in the open market, approved by the Purchasing Division Director, shall not constitute a breach of this Contract and shall not entitle the Vendor to any form of compensation or damages. This provision does not excuse the State from fulfilling its obligations under a One Time Purchase contract.
8. **REQUIRED DOCUMENTS:** All of the items checked below must be provided to the Purchasing Division by the Vendor as specified below.
- BID BOND:** All Vendors shall furnish a bid bond in the amount of five percent (5%) of the total amount of the bid protecting the State of West Virginia. The bid bond must be submitted with the bid.

[] **PERFORMANCE BOND:** The apparent successful Vendor shall provide a performance bond in the amount of []. The performance bond must be issued and received by the Purchasing Division prior to Contract award. On construction contracts, the performance bond must be 100% of the Contract value.

[] **LABOR/MATERIAL PAYMENT BOND:** The apparent successful Vendor shall provide a labor/material payment bond in the amount of 100% of the Contract value. The labor/material payment bond must be issued and delivered to the Purchasing Division prior to Contract award.

In lieu of the Bid Bond, Performance Bond, and Labor/Material Payment Bond, the Vendor may provide certified checks, cashier's checks, or irrevocable letters of credit. Any certified check, cashier's check, or irrevocable letter of credit provided in lieu of a bond must be of the same amount and delivered on the same schedule as the bond it replaces. A letter of credit submitted in lieu of a performance and labor/material payment bond will only be allowed for projects under \$100,000. Personal or business checks are not acceptable.

[] **MAINTENANCE BOND:** The apparent successful Vendor shall provide a two (2) year maintenance bond covering the roofing system. The maintenance bond must be issued and delivered to the Purchasing Division prior to Contract award.

[] **WORKERS' COMPENSATION INSURANCE:** The apparent successful Vendor shall have appropriate workers' compensation insurance and shall provide proof thereof upon request.

[] **INSURANCE:** The apparent successful Vendor shall furnish proof of the following insurance prior to Contract award:

[] **Commercial General Liability Insurance:** [] or more.

[] **Builders Risk Insurance:** builders risk – all risk insurance in an amount equal to 100% of the amount of the Contract.

[] []

[] []

[] []

[] []

[] []

The apparent successful Vendor shall also furnish proof of any additional insurance requirements contained in the specifications prior to Contract award regardless of whether or not that insurance requirement is listed above.

[] **LICENSE(S) / CERTIFICATIONS / PERMITS:** In addition to anything required under the Section entitled Licensing, of the General Terms and Conditions, the apparent successful Vendor shall furnish proof of the following licenses, certifications, and/or permits prior to Contract award, in a form acceptable to the Purchasing Division.

[]	
[]	
[]	
[]	

The apparent successful Vendor shall also furnish proof of any additional licenses or certifications contained in the specifications prior to Contract award regardless of whether or not that requirement is listed above.

9. LITIGATION BOND: The Director reserves the right to require any Vendor that files a protest of an award to submit a litigation bond in the amount equal to one percent of the lowest bid submitted or \$5,000, whichever is greater. The entire amount of the bond shall be forfeited if the hearing officer determines that the protest was filed for frivolous or improper purpose, including but not limited to, the purpose of harassing, causing unnecessary delay, or needless expense for the Agency. All litigation bonds shall be made payable to the Purchasing Division. In lieu of a bond, the protester may submit a cashier's check or certified check payable to the Purchasing Division. Cashier's or certified checks will be deposited with and held by the State Treasurer's office. If it is determined that the protest has not been filed for frivolous or improper purpose, the bond or deposit shall be returned in its entirety.

10. ALTERNATES: Any model, brand, or specification listed herein establishes the acceptable level of quality only and is not intended to reflect a preference for, or in any way favor, a particular brand or vendor. Vendors may bid alternates to a listed model or brand provided that the alternate is at least equal to the model or brand and complies with the required specifications. The equality of any alternate being bid shall be determined by the State at its sole discretion. Any Vendor bidding an alternate model or brand should clearly identify the alternate items in its bid and should include manufacturer's specifications, industry literature, and/or any other relevant documentation demonstrating the equality of the alternate items. Failure to provide information for alternate items may be grounds for rejection of a Vendor's bid.

11. EXCEPTIONS AND CLARIFICATIONS: The Solicitation contains the specifications that shall form the basis of a contractual agreement. Vendor shall clearly mark any exceptions, clarifications, or

other proposed modifications in its bid. Exceptions to, clarifications of, or modifications of a requirement or term and condition of the Solicitation may result in bid disqualification.

12. LIQUIDATED DAMAGES: Vendor shall pay liquidated damages in the amount

n/a	for	n/a

This clause shall in no way be considered exclusive and shall not limit the State or Agency's right to pursue any other available remedy.

13. ACCEPTANCE/REJECTION: The State may accept or reject any bid in whole, or in part. Vendor's signature on its bid signifies acceptance of the terms and conditions contained in the Solicitation and Vendor agrees to be bound by the terms of the Contract, as reflected in the Purchase Order, upon receipt.

14. REGISTRATION: Prior to Contract award, the apparent successful Vendor must be properly registered with the West Virginia Purchasing Division and must have paid the \$125 fee if applicable.

15. COMMUNICATION LIMITATIONS: In accordance with West Virginia Code of State Rules §148-1-6.6, communication with the State of West Virginia or any of its employees regarding this Solicitation during the solicitation, bid, evaluation or award periods, except through the Purchasing Division, is strictly prohibited without prior Purchasing Division approval. Purchasing Division approval for such communication is implied for all agency delegated and exempt purchases.

16. FUNDING: This Contract shall continue for the term stated herein, contingent upon funds being appropriated by the Legislature or otherwise being made available. In the event funds are not appropriated or otherwise made available, this Contract becomes void and of no effect beginning on July 1 of the fiscal year for which funding has not been appropriated or otherwise made available.

17. PAYMENT: Payment in advance is prohibited under this Contract. Payment may only be made after the delivery and acceptance of goods or services. The Vendor shall submit invoices, in arrears, to the Agency at the address on the face of the purchase order labeled "Invoice To."

18. UNIT PRICE: Unit prices shall prevail in cases of a discrepancy in the Vendor's bid.

19. DELIVERY: All quotations are considered freight on board destination ("F.O.B. destination") unless alternate shipping terms are clearly identified in the bid. Vendor's listing of shipping terms that contradict the shipping terms expressly required by this Solicitation may result in bid disqualification.

20. INTEREST: Interest attributable to late payment will only be permitted if authorized by the West Virginia Code. Presently, there is no provision in the law for interest on late payments.

21. PREFERENCE: Vendor Preference may only be granted upon written request and only in accordance with the West Virginia Code § 5A-3-37 and the West Virginia Code of State Rules. A Resident Vendor Certification form has been attached hereto to allow Vendor to apply for the preference. Vendor's

failure to submit the Resident Vendor Certification form with its bid will result in denial of Vendor Preference. Vendor Preference does not apply to construction projects.

22. **SMALL, WOMEN-OWNED, OR MINORITY-OWNED BUSINESSES:** For any solicitations publicly advertised for bid on or after July 1, 2012, in accordance with West Virginia Code §5A-3-37(a)(7) and W. Va. CSR § 148-22-9, any non-resident vendor certified as a small, women-owned, or minority-owned business under W. Va. CSR § 148-22-9 shall be provided the same preference made available to any resident vendor. Any non-resident small, women-owned, or minority-owned business must identify itself as such in writing, must submit that writing to the Purchasing Division with its bid, and must be properly certified under W. Va. CSR § 148-22-9 prior to submission of its bid to receive the preferences made available to resident vendors. Preference for a non-resident small, women-owned, or minority owned business shall be applied in accordance with W. Va. CSR § 148-22-9.
23. **TAXES:** The Vendor shall pay any applicable sales, use, personal property or any other taxes arising out of this Contract and the transactions contemplated thereby. The State of West Virginia is exempt from federal and state taxes and will not pay or reimburse such taxes.
24. **CANCELLATION:** The Purchasing Division Director reserves the right to cancel this Contract immediately upon written notice to the vendor if the materials or workmanship supplied do not conform to the specifications contained in the Contract. The Purchasing Division Director may cancel any purchase or Contract upon 30 days written notice to the Vendor in accordance with West Virginia Code of State Rules § 148-1-7.16.2.
25. **WAIVER OF MINOR IRREGULARITIES:** The Director reserves the right to waive minor irregularities in bids or specifications in accordance with West Virginia Code of State Rules § 148-1-4.6.
26. **TIME:** Time is of the essence with regard to all matters of time and performance in this Contract.
27. **APPLICABLE LAW:** This Contract is governed by and interpreted under West Virginia law without giving effect to its choice of law principles. Any information provided in specification manuals, or any other source, verbal or written, which contradicts or violates the West Virginia Constitution, West Virginia Code or West Virginia Code of State Rules is void and of no effect.
28. **COMPLIANCE:** Vendor shall comply with all applicable federal, state, and local laws, regulations and ordinances. By submitting a bid, Vendors acknowledge that they have reviewed, understand, and will comply with all applicable law.
29. **PREVAILING WAGE:** On any contract for the construction of a public improvement, Vendor and any subcontractors utilized by Vendor shall pay a rate or rates of wages which shall not be less than the fair minimum rate or rates of wages (prevailing wage), as established by the West Virginia Division of Labor under West Virginia Code §§ 21-5A-1 et seq. and available at <http://www.sos.wv.gov/administrative-law/wagerates/Pages/default.aspx>. Vendor shall be responsible for ensuring compliance with prevailing wage requirements and determining when prevailing wage

requirements are applicable. The required contract provisions contained in West Virginia Code of State Rules § 42-7-3 are specifically incorporated herein by reference.

- 30. ARBITRATION:** Any references made to arbitration contained in this Contract, Vendor's bid, or in any American Institute of Architects documents pertaining to this Contract are hereby deleted, void, and of no effect.
- 31. MODIFICATIONS:** This writing is the parties' final expression of intent. Notwithstanding anything contained in this Contract to the contrary, no modification of this Contract shall be binding without mutual written consent of the Agency, and the Vendor, with approval of the Purchasing Division and the Attorney General's office (Attorney General approval is as to form only). **No Change shall be implemented by the Vendor until such time as the Vendor receives an approved written change order from the Purchasing Division.**
- 32. WAIVER:** The failure of either party to insist upon a strict performance of any of the terms or provision of this Contract, or to exercise any option, right, or remedy herein contained, shall not be construed as a waiver or a relinquishment for the future of such term, provision, option, right, or remedy, but the same shall continue in full force and effect. Any waiver must be expressly stated in writing and signed by the waiving party.
- 33. SUBSEQUENT FORMS:** The terms and conditions contained in this Contract shall supersede any and all subsequent terms and conditions which may appear on any form documents submitted by Vendor to the Agency or Purchasing Division such as price lists, order forms, invoices, sales agreements, or maintenance agreements, and includes internet websites or other electronic documents. Acceptance or use of Vendor's forms does not constitute acceptance of the terms and conditions contained thereon.
- 34. ASSIGNMENT:** Neither this Contract nor any monies due, or to become due hereunder, may be assigned by the Vendor without the express written consent of the Agency, the Purchasing Division, the Attorney General's office (as to form only), and any other government agency or office that may be required to approve such assignments. Notwithstanding the foregoing, Purchasing Division approval may or may not be required on certain agency delegated or exempt purchases.
- 35. WARRANTY:** The Vendor expressly warrants that the goods and/or services covered by this Contract will: (a) conform to the specifications, drawings, samples, or other description furnished or specified by the Agency; (b) be merchantable and fit for the purpose intended; and (c) be free from defect in material and workmanship.
- 36. STATE EMPLOYEES:** State employees are not permitted to utilize this Contract for personal use and the Vendor is prohibited from permitting or facilitating the same.
- 37. BANKRUPTCY:** In the event the Vendor files for bankruptcy protection, the State of West Virginia may deem this Contract null and void, and terminate this Contract without notice.

- 38. HIPAA BUSINESS ASSOCIATE ADDENDUM:** The West Virginia State Government HIPAA Business Associate Addendum (BAA), approved by the Attorney General, is available online at <http://www.state.wv.us/admin/purchase/vrc/hipaa.html> and is hereby made part of the agreement provided that the Agency meets the definition of a Covered entity (45 CFR §160.103) and will be disclosing Protected Health Information (45 CFR §160.103) to the Vendor. Additionally, the HIPAA Privacy, Security, Enforcement & Breach Notification Final Omnibus Rule was published on January 25, 2013. It may be viewed online at <http://www.gpo.gov/fdsys/pkg/FR-2013-01-25/pdf/2013-01073.pdf>. Any organization, that qualifies as the Agency's Business Associate, is expected to be in compliance with this Final Rule. For those Business Associates entering into contracts with a HIPAA Covered State Agency between January 25, 2013 and the release of the 2013 WV State Agency Business Associate Agreement, or September 23, 2013 (whichever is earlier), be advised that you will be required to comply with the 2013 WV State Agency Business Associate Agreement. For those Business Associates with contracts with a HIPAA Covered State Agency executed prior to January 25, 2013, be advised that upon renewal or modification, you will be required to comply with the 2013 WV State Agency Business Associate Agreement no later than September 22, 2014.
- 39. CONFIDENTIALITY:** The Vendor agrees that it will not disclose to anyone, directly or indirectly, any such personally identifiable information or other confidential information gained from the Agency, unless the individual who is the subject of the information consents to the disclosure in writing or the disclosure is made pursuant to the Agency's policies, procedures, and rules. Vendor further agrees to comply with the Confidentiality Policies and Information Security Accountability Requirements, set forth in <http://www.state.wv.us/admin/purchase/privacy/default.html>.
- 40. DISCLOSURE:** Vendor's response to the Solicitation and the resulting Contract are considered public documents and will be disclosed to the public in accordance with the laws, rules, and policies governing the West Virginia Purchasing Division. Those laws include, but are not limited to, the Freedom of Information Act found in West Virginia Code § 29B-1-1 et seq.

If a Vendor considers any part of its bid to be exempt from public disclosure, Vendor must so indicate by specifically identifying the exempt information, identifying the exemption that applies, providing a detailed justification for the exemption, segregating the exempt information from the general bid information, and submitting the exempt information as part of its bid but in a segregated and clearly identifiable format. Failure to comply with the foregoing requirements will result in public disclosure of the Vendor's bid without further notice. A Vendor's act of marking all or nearly all of its bid as exempt is not sufficient to avoid disclosure and WILL NOT BE HONORED. Vendor's act of marking a bid or any part thereof as "confidential" or "proprietary" is not sufficient to avoid disclosure and WILL NOT BE HONORED. In addition, a legend or other statement indicating that all or substantially all of the bid is exempt from disclosure is not sufficient to avoid disclosure and WILL NOT BE HONORED. Vendor will be required to defend any claimed exemption for nondisclosure in the event of an administrative or judicial challenge to the State's nondisclosure. Vendor must indemnify the State for any costs incurred related to any exemptions claimed by Vendor. Any questions regarding the applicability of the various public records laws should be addressed to your own legal counsel prior to bid submission.

- 41. LICENSING:** In accordance with West Virginia Code of State Rules §148-1-6.1.7, Vendor must be licensed and in good standing in accordance with any and all state and local laws and requirements by any state or local agency of West Virginia, including, but not limited to, the West Virginia Secretary of State's Office, the West Virginia Tax Department, West Virginia Insurance Commission, or any other state agency or political subdivision. Upon request, the Vendor must provide all necessary releases to obtain information to enable the Purchasing Division Director or the Agency to verify that the Vendor is licensed and in good standing with the above entities.
- 42. ANTITRUST:** In submitting a bid to, signing a contract with, or accepting a Purchase Order from any agency of the State of West Virginia, the Vendor agrees to convey, sell, assign, or transfer to the State of West Virginia all rights, title, and interest in and to all causes of action it may now or hereafter acquire under the antitrust laws of the United States and the State of West Virginia for price fixing and/or unreasonable restraints of trade relating to the particular commodities or services purchased or acquired by the State of West Virginia. Such assignment shall be made and become effective at the time the purchasing agency tenders the initial payment to Vendor.
- 43. VENDOR CERTIFICATIONS:** By signing its bid or entering into this Contract, Vendor certifies (1) that its bid was made without prior understanding, agreement, or connection with any corporation, firm, limited liability company, partnership, person or entity submitting a bid for the same material, supplies, equipment or services; (2) that its bid is in all respects fair and without collusion or fraud; (3) that this Contract is accepted or entered into without any prior understanding, agreement, or connection to any other entity that could be considered a violation of law; and (4) that it has reviewed this RFQ in its entirety; understands the requirements, terms and conditions, and other information contained herein. Vendor's signature on its bid also affirms that neither it nor its representatives have any interest, nor shall acquire any interest, direct or indirect, which would compromise the performance of its services hereunder. Any such interests shall be promptly presented in detail to the Agency.

The individual signing this bid on behalf of Vendor certifies that he or she is authorized by the Vendor to execute this bid or any documents related thereto on Vendor's behalf; that he or she is authorized to bind the Vendor in a contractual relationship; and that, to the best of his or her knowledge, the Vendor has properly registered with any State agency that may require registration.

- 44. PURCHASING CARD ACCEPTANCE:** The State of West Virginia currently utilizes a Purchasing Card program, administered under contract by a banking institution, to process payment for goods and services. The Vendor must accept the State of West Virginia's Purchasing Card for payment of all orders under this Contract unless the box below is checked.

Vendor is not required to accept the State of West Virginia's Purchasing Card as payment for all goods and services.

- 45. VENDOR RELATIONSHIP:** The relationship of the Vendor to the State shall be that of an independent contractor and no principal-agent relationship or employer-employee relationship is contemplated or created by this Contract. The Vendor as an independent contractor is solely liable for the acts and omissions of its employees and agents. Vendor shall be responsible for selecting,

supervising, and compensating any and all individuals employed pursuant to the terms of this Solicitation and resulting contract. Neither the Vendor, nor any employees or subcontractors of the Vendor, shall be deemed to be employees of the State for any purpose whatsoever. Vendor shall be exclusively responsible for payment of employees and contractors for all wages and salaries, taxes, withholding payments, penalties, fees, fringe benefits, professional liability insurance premiums, contributions to insurance and pension, or other deferred compensation plans, including but not limited to, Workers' Compensation and Social Security obligations, licensing fees, *etc.* and the filing of all necessary documents, forms and returns pertinent to all of the foregoing. Vendor shall hold harmless the State, and shall provide the State and Agency with a defense against any and all claims including, but not limited to, the foregoing payments, withholdings, contributions, taxes, Social Security taxes, and employer income tax returns.

- 46. INDEMNIFICATION:** The Vendor agrees to indemnify, defend, and hold harmless the State and the Agency, their officers, and employees from and against: (1) Any claims or losses for services rendered by any subcontractor, person, or firm performing or supplying services, materials, or supplies in connection with the performance of the Contract; (2) Any claims or losses resulting to any person or entity injured or damaged by the Vendor, its officers, employees, or subcontractors by the publication, translation, reproduction, delivery, performance, use, or disposition of any data used under the Contract in a manner not authorized by the Contract, or by Federal or State statutes or regulations; and (3) Any failure of the Vendor, its officers, employees, or subcontractors to observe State and Federal laws including, but not limited to, labor and wage and hour laws.
- 47. PURCHASING AFFIDAVIT:** In accordance with West Virginia Code § 5A-3-10a, all Vendors are required to sign, notarize, and submit the Purchasing Affidavit stating that neither the Vendor nor a related party owe a debt to the State in excess of \$1,000. The affidavit must be submitted prior to award, but should be submitted with the Vendor's bid. A copy of the Purchasing Affidavit is included herewith.
- 48. ADDITIONAL AGENCY AND LOCAL GOVERNMENT USE:** This Contract may be utilized by and extends to other agencies, spending units, and political subdivisions of the State of West Virginia; county, municipal, and other local government bodies; and school districts ("Other Government Entities"). This Contract shall be extended to the aforementioned Other Government Entities on the same prices, terms, and conditions as those offered and agreed to in this Contract. If the Vendor does not wish to extend the prices, terms, and conditions of its bid and subsequent contract to the Other Government Entities, the Vendor must clearly indicate such refusal in its bid. A refusal to extend this Contract to the Other Government Entities shall not impact or influence the award of this Contract in any manner.
- 49. CONFLICT OF INTEREST:** Vendor, its officers or members or employees, shall not presently have or acquire any interest, direct or indirect, which would conflict with or compromise the performance of its obligations hereunder. Vendor shall periodically inquire of its officers, members and employees to ensure that a conflict of interest does not arise. Any conflict of interest discovered shall be promptly presented in detail to the Agency.

50. REPORTS: Vendor shall provide the Agency and/or the Purchasing Division with the following reports identified by a checked box below:

- Such reports as the Agency and/or the Purchasing Division may request. Requested reports may include, but are not limited to, quantities purchased, agencies utilizing the contract, total contract expenditures by agency, etc.
- Quarterly reports detailing the total quantity of purchases in units and dollars, along with a listing of purchases by agency. Quarterly reports should be delivered to the Purchasing Division via email at purchasing.requisitions@wv.gov.

51. BACKGROUND CHECK: In accordance with W. Va. Code § 15-2D-3, the Director of the Division of Protective Services shall require any service provider whose employees are regularly employed on the grounds or in the buildings of the Capitol complex or who have access to sensitive or critical information to submit to a fingerprint-based state and federal background inquiry through the state repository. The service provider is responsible for any costs associated with the fingerprint-based state and federal background inquiry.

After the contract for such services has been approved, but before any such employees are permitted to be on the grounds or in the buildings of the Capitol complex or have access to sensitive or critical information, the service provider shall submit a list of all persons who will be physically present and working at the Capitol complex to the Director of the Division of Protective Services for purposes of verifying compliance with this provision.

The State reserves the right to prohibit a service provider's employees from accessing sensitive or critical information or to be present at the Capitol complex based upon results addressed from a criminal background check.

Service providers should contact the West Virginia Division of Protective Services by phone at (304) 558-9911 for more information.

52. PREFERENCE FOR USE OF DOMESTIC STEEL PRODUCTS: Except when authorized by the Director of the Purchasing Division pursuant to W. Va. Code § 5A-3-56, no contractor may use or supply steel products for a State Contract Project other than those steel products made in the United States. A contractor who uses steel products in violation of this section may be subject to civil penalties pursuant to W. Va. Code § 5A-3-56. As used in this section:

- a. "State Contract Project" means any erection or construction of, or any addition to, alteration of or other improvement to any building or structure, including, but not limited to, roads or highways, or the installation of any heating or cooling or ventilating plants or other equipment, or the supply of and materials for such projects, pursuant to a contract with the State of West Virginia for which bids were solicited on or after June 6, 2001.
- b. "Steel Products" means products rolled, formed, shaped, drawn, extruded, forged, cast, fabricated or otherwise similarly processed, or processed by a combination of two or more or

such operations, from steel made by the open hearth, basic oxygen, electric furnace, Bessemer or other steel making process.

The Purchasing Division Director may, in writing, authorize the use of foreign steel products if:

- a. The cost for each contract item used does not exceed one tenth of one percent (.1%) of the total contract cost or two thousand five hundred dollars (\$2,500.00), whichever is greater. For the purposes of this section, the cost is the value of the steel product as delivered to the project; or
- b. The Director of the Purchasing Division determines that specified steel materials are not produced in the United States in sufficient quantity or otherwise are not reasonably available to meet contract requirements.

53. PREFERENCE FOR USE OF DOMESTIC ALUMINUM, GLASS, AND STEEL: In Accordance with W. Va. Code § 5-19-1 et seq., and W. Va. CSR § 148-10-1 et seq., for every contract or subcontract, subject to the limitations contained herein, for the construction, reconstruction, alteration, repair, improvement or maintenance of public works or for the purchase of any item of machinery or equipment to be used at sites of public works, only domestic aluminum, glass or steel products shall be supplied unless the spending officer determines, in writing, after the receipt of offers or bids, (1) that the cost of domestic aluminum, glass or steel products is unreasonable or inconsistent with the public interest of the State of West Virginia, (2) that domestic aluminum, glass or steel products are not produced in sufficient quantities to meet the contract requirements, or (3) the available domestic aluminum, glass, or steel do not meet the contract specifications. This provision only applies to public works contracts awarded in an amount more than fifty thousand dollars (\$50,000) or public works contracts that require more than ten thousand pounds of steel products.

The cost of domestic aluminum, glass, or steel products may be unreasonable if the cost is more than twenty percent (20%) of the bid or offered price for foreign made aluminum, glass, or steel products. If the domestic aluminum, glass or steel products to be supplied or produced in a "substantial labor surplus area", as defined by the United States Department of Labor, the cost of domestic aluminum, glass, or steel products may be unreasonable if the cost is more than thirty percent (30%) of the bid or offered price for foreign made aluminum, glass, or steel products.

This preference shall be applied to an item of machinery or equipment, as indicated above, when the item is a single unit of equipment or machinery manufactured primarily of aluminum, glass or steel, is part of a public works contract and has the sole purpose or of being a permanent part of a single public works project. This provision does not apply to equipment or machinery purchased by a spending unit for use by that spending unit and not as part of a single public works project.

All bids and offers including domestic aluminum, glass or steel products that exceed bid or offer prices including foreign aluminum, glass or steel products after application of the preferences provided in this provision may be reduced to a price equal to or lower than the lowest bid or offer price for foreign aluminum, glass or steel products plus the applicable preference. If the reduced bid or offer prices are made in writing and supersede the prior bid or offer prices, all bids or offers, including the reduced bid or offer prices, will be reevaluated in accordance with this rule.

CERTIFICATION AND SIGNATURE PAGE

By signing below, I certify that I have reviewed this Solicitation in its entirety; understand the requirements, terms and conditions, and other information contained herein; that I am submitting this bid or proposal for review and consideration; that I am authorized by the bidder to execute this bid or any documents related thereto on bidder's behalf; that I am authorized to bind the bidder in a contractual relationship; and that to the best of my knowledge, the bidder has properly registered with any State agency that may require registration.

Heritage Equipment, Inc.

(Company)

Carl L. Hubbard, VP

(Authorized Signature)

Carl L. Hubbard, Vice President

(Representative Name, Title)

304-254-7827

(Phone Number)

304-254-9007

(Fax Number)

7-3-13

(Date)

ADDENDUM ACKNOWLEDGEMENT FORM
SOLICITATION NO.: 70135014

Instructions: Please acknowledge receipt of all addenda issued with this solicitation by completing this addendum acknowledgment form. Check the box next to each addendum received and sign below. Failure to acknowledge addenda may result in bid disqualification.

Acknowledgment: I hereby acknowledge receipt of the following addenda and have made the necessary revisions to my proposal, plans and/or specification, etc.

Addendum Numbers Received:

(Check the box next to each addendum received)

NONE

- | | |
|---|--|
| <input type="checkbox"/> Addendum No. 1 | <input type="checkbox"/> Addendum No. 6 |
| <input type="checkbox"/> Addendum No. 2 | <input type="checkbox"/> Addendum No. 7 |
| <input type="checkbox"/> Addendum No. 3 | <input type="checkbox"/> Addendum No. 8 |
| <input type="checkbox"/> Addendum No. 4 | <input type="checkbox"/> Addendum No. 9 |
| <input type="checkbox"/> Addendum No. 5 | <input type="checkbox"/> Addendum No. 10 |

I understand that failure to confirm the receipt of addenda may be cause for rejection of this bid. I further understand that any verbal representation made or assumed to be made during any oral discussion held between Vendor's representatives and any state personnel is not binding. Only the information issued in writing and added to the specifications by an official addendum is binding.

Heritage Equipment Inc.

Company

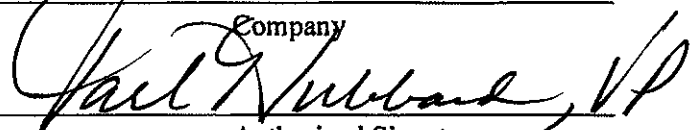

Authorized Signature

7-3-13

Date

NOTE: This addendum acknowledgment should be submitted with the bid to expedite document processing.

SPECIFICATIONS

1. **PURPOSE AND SCOPE:** The West Virginia Purchasing Division is soliciting bids on behalf of West Virginia Department of Transportation/Division of Highways to establish a contract for the one time purchase of a cab and chassis.
2. **DEFINITIONS:** The terms listed below shall have the meanings assigned to them below. Additional definitions can be found in section 2 of the General Terms and Conditions.
 - 2.1 **"Contract Item"** means Cab and Chassis.
 - 2.2 **"Pricing Page"** means the page upon which Vendor should list its proposed price for the Desired Items in the manner requested by thereon. The Desired Item is either included on the last page of this RFQ or attached hereto as Exhibit A.
 - 2.3 **"RFQ"** means the official RFQ published by the Purchasing Division and identified as 70135014.
 - 2.4 **"GVW"** means gross vehicle weight.
 - 2.5 **"RPM"** means revolutions per minute.
 - 2.6 **"MPH"** means miles per hour.
 - 2.7 **"PTO"** means power take off.
 - 2.8 **"CFM"** means cubic feet per minute.
 - 2.9 **"PSI"** means pounds per square inch.
 - 2.10 **"US FMVSS"** means United States Department of Transportation Federal Motor Vehicle Safety Standards.
3. **GENERAL REQUIREMENTS:**
 - 3.1 **Mandatory Contract Item Requirements:** Contract Item must meet or exceed the mandatory requirements listed below.

REQUEST FOR QUOTATION
70135014 Cab and Chassis

3.1.1 Cab and Chassis, Axle Forward Design, Freightliner 114SD or equal must:

3.1.1.1 Have 60,000 lbs. GVW Capacity.

3.1.1.2 Have a GVW Plate Rating of 60,000 lbs. minimum.

3.1.1.3 Have a Wheel Base 239" minimum.

3.1.2 Cab - The following are mandatory requirements related to the cab.

3.1.1.1 The cab shall be the manufacturer's standard steel and/or fiberglass, and/or aluminum with premium or manufacturers highest level interior trim with inside noise level rating not to exceed 80dba; all must be in compliance with US FMVSS certifications.

3.1.3 Interior of Cab – The following are mandatory requirements related to the cabs interior.

3.1.3.1 Driver seat must have fully adjustable high back with head rest, air ride, bucket style; seat must include air lumbar, hip bolsters, side bolsters, and back bolsters , with full cloth on entire seat and material must be Modura or approved equivalent.

3.1.3.2 Passenger seat shall be fully adjustable high back with head rest, air ride, bucket style; cloth covered or minimum of cloth insert in vinyl. Clearance between drivers and passenger seats shall be a minimum of 12 inches.

3.1.3.3 Shall have adjustable tilt telescoping steering column.

3.1.3.4 Must have interior sun visors for both driver and passenger.

3.1.3.5 Must have heater, defroster, and air conditioner.

3.1.3.6 Must have a 5 lb. fire extinguisher.

3.1.3.7 Floor mats shall be through cab area with non-absorbent backing.

3.1.3.8 Shall have dash mounted ashtray without lighter.

3.1.3.9 Shall have forward roof mounted console with upper storage compartments without netting. (package has netting standard, will be removed)

3.1.3.10 Must have two (2) cup holders dash mounted.

3.1.3.11 Shall have interior 3-way dome light.

3.1.3.12 Must have electric door locks and windows.

3.1.3.13 Must supply 1-12 volt power supply in dash.

3.1.3.14 Must have door panel arm rests for driver and passenger.
Top of door panel below window serves as
an arm rest.

3.1.4 Cab Exterior – The following are mandatory requirements related to the cab exterior and shall include:

3.1.4.1 Air cab mounts.

3.1.4.2 Non-removable bug screen mounted behind grille.

3.1.4.3 3 ½" fender extensions. Exception 2"

REQUEST FOR QUOTATION
70135014 Cab and Chassis

3.1.4.4 Door locks and ignition switch keyed alike.

3.1.4.5 Grab handles: left and right hand mounted.

3.1.4.6 Stationary black grille. Stationary, but Chrome

3.1.4.7 Fiberglass hood.

3.1.4.8 Single 14" round polished air horn roof mounted.

Exception: 26" rectangular

3.1.4.9 Single electric horn.

3.1.4.10 Single horn shield

3.1.4.11 Dual West Coast style, bright finish, heated mirrors with left hand and right hand remote.

3.1.4.12 Glass shall be manufacturers tinted safety glass; front, sides and rear.

3.1.4.13 Windshield wipers and washers: Manufacturers heaviest duty artic type with intermittent features and 8 liter wind shield washer reservoir cab mounted. W/S 1.5 gallon

3.1.5 Instruments – The following are mandatory requirements related to the Manufacturer's gauges with visual and/or audible and/or programmable warning to inform driver when operating conditions are exceeded, and shall include:

3.1.5.1 Low air pressure light and buzzer.

3.1.5.2 Single brake application air gauge.

3.1.5.3 2" primary and secondary air pressure gauges.

3.1.5.4 Dash mounted air restriction indicator with graduations.

3.1.5.5 97db back-up alarm.

3.1.5.6 Electronic cruise control.

3.1.5.7 Key operated ignition switch.

3.1.5.8 Odometer

3.1.5.9 Hour meter *See Note Below under trip miles

3.1.5.10 Voltmeter

3.1.5.11 Fuel gauge

3.1.5.12 Temperature gauge

3.1.5.13 Transmission oil temperature gauge

3.1.5.14 Engine and trip hour meter display *Day Star Code includes
Hour Meter & Trip Miles

3.1.5.15 Oil pressure gauge

REQUEST FOR QUOTATION
70135014 Cab and Chassis

3.1.5.16 Electric engine coolant temperature gauge

3.1.5.17 AM/FM radio

3.1.6. Engine – The following are mandatory requirements related to the engine and shall include:

3.1.6.1 Cummins ISL 370 HP or equal @ 2000 RPM; 2100 Gov RPM, 1250 LB/FT @ 1400 RPM.

3.1.6.2 Max Road Speed 69 MPH

3.1.6.3 Cruise control speed limit same as road speed limit.

3.1.6.4 PTO with programmable settings.

3.1.6.5 Alternator; Delco Remy or equal 12 volt 160 AMP, 28 Series Quadramount pad with remote battery volt sense.

3.1.6.6 Three (3) 12 volt maintenance free batteries, threaded stud, 3375 CCA, Group 31, Alliance Model 1231 or equal.

3.1.6.7 Frame mounted battery box with battery jumper studs.

Exception: (+) (-) terminal mounted on frame
next to starter

3.1.6.8 Positive Load disconnect with cab mounted control switch mounted outboard driver seat.

3.1.6.9 Cummins or equal 18.7 CFM air compressor with internal safety valve.

3.1.6.10 Electronic engine integral shutdown protection system.

3.1.6.11 Engine Exhaust Brake.

3.1.6.12 Engine Block Heater 1000 Watt/115 Volt Phillips-Temro or equal.

3.1.6.13 Black plastic engine heater receptacle mounted under left hand door.

3.1.6.14 Heavy duty 12 volt starter with integrated magnetic switch Delco 38MT or equal.

3.1.6.15 Aluminum radiator minimum of 1300 spin.

3.1.6.16 NOAT (Nitric Organic Acid Technology) Extend Life Antifreeze -34°F minimum or equal contained within the engine coolant system.

3.1.6.17 Coolant hoses, which will be Gages Blue Stripe or equal with constant tension hose clamps.

3.1.7 Exhaust Brake and Exhaust system- The following mandatory requirement is related to the Engine Exhaust Brake and the Exhaust System and shall include:

3.1.7.1 Engine exhaust brake must be right hand outboard understep mounted, horizontal after treatment system assembly with right hand B-Pillar mounted vertical tailpipe. This is a manufacturer's locate. Brake will be located at position where functional by engine and exhaust system

**REQUEST FOR QUOTATION
70135014 Cab and Chassis**

3.1.7.2 Exhaust system height 9'6" maximum.
11' 0" Federal minimum for sound abatement

3.1.7.3 Horizontal muffler and selective catalytic reduction chamber (can be referred to as after treatment system assembly) to be located under right side (passenger side) of cab and is not to extend beyond back side of cab, and is to include a vertical tailpipe mounted on right side rear of cab (this location is commonly called the B-Pillar) and is not to extend more than a maximum of 2 inches behind cab.

3.1.7.4 13 gallon diesel exhaust fluid tank.

3.1.7.5 Fan drive, on/off switch, Horton Drivemaster or equal.

3.1.8. Transmission – The following are mandatory requirements related to the transmission and shall include:

3.1.8.1 Allison 3000 RDS (Rugged Duty Series) automatic transmission with PTO provisions or equal.

3.1.8.2 Magnetic plugs for engine drain, transmission drain, as well as axle (s) fill and drain.

3.1.8.3 Push button, electronic shift control and dash mounted.

3.1.8.4 Synthetic Transmission Fluid, (Spec TES-295 Compliant; Industry standard).

3.1.9 Front Axle and Suspension – The following are mandatory requirements related to the front axle and suspension and shall include:

3.1.9.1 20,000 lb. front axle with 20,000 lb. flat leaf springs with heavy duty shock absorbers.

3.1.9.2 Front oil seals SKF Scotseal Plus XL or equal

3.1.9.3 Vented front hub caps with windows, center and side plugs – oil

3.1.9.4 Automatic front slack adjusters, Meritor or equal.

3.1.9.5 TRW THP-60 or equal Power steering, with RCH45 or equal auxiliary gear.

3.1.9.6 Power steering reservoir 4 Qt. minimum.

3.1.9.7 Oil/Air power steering cooler, synthetic front axle oil.

3.1.9.8 Maintenance free rubber bushings – front suspension, front shock absorbers. Exception: threaded front spring pins and bushings in lieu of maintenance free- not available with leaf springs.

3.1.10 Rear Axle and Suspension – The following are mandatory requirements related to the rear axle and suspension and shall include:

3.1.10.1 40,000 lb. rear axle and 40,000 lb. flat leaf rear springs with heavy duty crossmembers and heavy duty fore/aft control rods.

3.1.10.2 4.78 rear axle ratio Ratio to be determined at time of bid award. This ratio may not be available with requested rear axle assembly

3.1.10.3 Extended lube interaxle driveline with half round yokes, Meritor MXL1TT or equal.

REQUEST FOR QUOTATION
70135014 Cab and Chassis

- 3.1.10.4 Drive controlled traction differential; both tandem rear axle.
- 3.1.10.5 Rear oil seals, SKF Scotseal Plus XL or equal.
- 3.1.10.6 Long stroke 2-drive axle spring, parking chambers, Haldex Goldseal or equal.
- 3.1.10.7 Automatic rear slack adjuster, Meritor or equal.
- 3.1.10.8 Synthetic rear axle oil.
- 3.1.10.9 52" minimum axle spacing.
- 3.1.11 Brakes – The following are mandatory requirements related to the brakes.
 - 3.1.11.1 Shall have air dryer with integral air governor and heated, Wabco SS-1200 plug or equal.
- 3.1.12 Frame – The following are mandatory requirements related to the frame and shall include:
 - 3.1.12.1 Wheelbase 239" minimum
 - 3.1.12.2 Frame minimum 11/32 x 3" – ½ x 10 15/16" steel frame 120,000 psi yield strength.
 - 3.1.12.3 ¼" minimum C-channel inner frame reinforcement.
 - 3.1.12.4 63" minimum rear frame overhang. W/S = 64"

3.1.12.5 Cab to rear axle 152" minimum.
157.78"

3.1.12.6 16 ½" minimum painted steel straight bumper.
Exception" 16" with W/S

3.1.13 Fuel Tank – The following are mandatory requirements related to the fuel tank.

3.1.13.1 Shall have a 60 gallon minimum aluminum fuel tank (left hand mounted); 25" diameter minimum.

3.1.13.2 Shall include fuel filter/water separator.

3.1.14 Tires/wheels – The following are mandatory requirements related to the tires and wheels and shall include:

3.1.14.1 Front – 445/65R22.5 20 ply radial Michelin XYZ-3 or equal.

3.1.14.2 Rear tires – 11R22.5 16 ply radial Michelin XDE radial or equal.

3.1.14.3 Front wheel 22.5 x 12.25 10-hub pilot 4.75 inset, 5-hand steel disc Accuride 29807 or equal.

3.1.14.4 Rear wheel 22.5 x 8.25 10-hub pilot 2-hand HD steel disc Accuride 28828 or equal.

3.1.15 Paint – The following are mandatory requirements related to the color of unit. The following shall be painted:

3.1.15.1 Cab – White

REQUEST FOR QUOTATION
70135014 Cab and Chassis

3.1.15.2 Chassis – Black, high polyurethane Chassis paint.

3.1.15.3 Wheel Rims – Vender White

3.1.15.4 Bumper – Standard black bumper paint.

4. CONTRACT AWARD:

4.1 Contract Award: The Contract is intended to provide Agencies with a purchase price for the Contract Items. The Contract shall be awarded to the Vendor that provides the Contract Items meeting the required specifications for the lowest overall total cost as shown on the Pricing Pages.

4.2 Bid Evaluation Page: Vendor should complete the Bid Evaluation Page (Exhibit A) by inserting the Year, Make, Model and inserting quoted price. Vendor should complete the Bid Evaluation Page in full as failure to complete the Bid Evaluation Page in its entirety may result in Vendor's bid being disqualified.

Notwithstanding the foregoing, the Purchasing Division may correct errors as it deems appropriate. Vendor should type or electronically enter the information into the Bid Evaluation Page to prevent errors in the evaluation.

5. PAYMENT:

5.1 Payment: Vendor shall accept payment in accordance with the payment procedures of the State of West Virginia.

6. DELIVERY AND RETURN:

6.1 Shipment and Delivery: Vendor shall ship the Contract Items immediately after being awarded this Contract and receiving a purchase order or notice to proceed. Vendor shall deliver the Contract Items within 120 working days after receiving a purchase order or notice to proceed. Contract Items must be delivered to Agency at WVDOT/Equipment Division, Rt. 33 and Brushy Fork Road, Buckhannon, WV 26201.

6.2 Late Delivery: The Agency placing the order under this Contract must be notified in writing if the shipment of the Contract Items will be delayed for any reason. Any delay in delivery that could cause harm to an Agency will be grounds for cancellation of the Contract, and/or obtaining the Contract Items from a third party.

Any Agency seeking to obtain the Contract Items from a third party under this provision must first obtain approval of the Purchasing Division.

6.3 Delivery Payment/Risk of Loss: Vendor shall deliver the Contract Items F.O.B. destination to the Agency's location.

7. MISCELLANEOUS

7.1 Operating and Service Manuals and Parts Lists: An operator's manual must be included with unit upon delivery. A "line sheet" (if applicable) and the "Equipment Preventative Maintenance Questionnaire", (Exhibit "B") must be with unit upon delivery, Attn: Marcia Lee. There must be 3 service/shop/ maintenance manuals and 3 parts manuals; CD-ROM is preferred in lieu of parts manuals. Manuals shall be delivered upon completion of delivery of unit. Failure to do so will delay payment.

7.2 Preventative Maintenance & Operator Procedures: Manufacturers and/or dealers will be required to submit to the Equipment Division, in addition to the operating and service manuals, booklets and pamphlets explaining the Preventative Maintenance and Operator Procedures to be used by the operators of this equipment, and must include such things as daily prestart inspection procedure, service schedule, and routine maintenance required, safety precautions, etc. The successful vendor shall furnish all training aids; i.e. videos, projectors as needed.

REQUEST FOR QUOTATION
70135014 Cab and Chassis

- 7.3 Warranty and Service Policy:** The unit must be accompanied upon delivery by the unit's manufacturers executed warranty and service policy.
- 7.4 Unspecified Accessories & Features:** All parts, equipment, accessories, material, design and performance characteristics not specified herein, but which are necessary to provide a complete unit, must be furnished with each unit and required to conform to strength, quality of material, and quality of workmanship to those which are advertised and provided to the market in general by the unit industry. All parts and accessories advertised and regularly supplied as standard shall be included, except those which would represent duplication of these specified and except those which, by specification, are not to be furnished. All standard safety features, required by Federal and State Law, shall be included.

Exhibit A

Cost Sheet

RFQ 70135014

Item Number	Estimated Quantity	Unit of Measure	Description	Unit Price	Total
1	1	Each	One complete unit: Cab and chassis	\$97,602.00	\$97,602.00

Vendor should also supply the year, make, and model of the following:

Cab and Chassis: 2014 Western Star Model 4700

Will be provided after bid award

EXHIBIT B

EQUIPMENT PREVENTATIVE MAINTENANCE QUESTIONNAIRE

THIS FORM MUST BE COMPLETED IN ITS ENTIRETY BY SUCCESSFUL BIDDER OR MANUFACTURER'S TECHNICAL REPRESENTATIVE PRIOR TO DELIVERY OF PILOT MODEL TO THE WVDOH.

DESCRIPTION: _____ MAKE: _____

MODEL: _____ YEAR: _____ PURCHASE AMOUNT: _____

ENGINE: MAKE: _____ MODEL: _____ FUEL TYPE: _____

HORSEPOWER: _____ CYLINDER: _____ ENGINE SERIAL: _____

COOLING SYSTEM CAPACITY: _____

BELTS: DESCRIPTION: _____ PART NUMBERS: _____

GVW: _____ AXLE CAPACITY: FRONT: _____ REAR: _____

TIRES: FRONT MAKE & SIZE: _____

REAR MAKE & SIZE: _____

DIMENSIONS OF UNIT: LENGTH: _____ WIDTH: _____ LENGTH: _____

VENDOR CONTACT PERSON: _____ PHONE: _____

PARTS:

BATTERY MAKE: _____ MODEL: _____ CCA: _____

TOP OR SIDE POST: _____ DIMENSIONS: LENGTH _____ WIDTH _____ HEIGHT _____

SPARK PLUGS OR FUEL INJECTORS MAKE: _____ PART # _____

FUEL PUMP OR INJECTION PUMP MAKE: _____ MODEL: _____

ALTERNATOR MAKE: _____ PART #: _____

STARTER MAKE: _____ PART #: _____

TURBO CHARGER MAKE: _____ PART #: _____

TRANS. MAKE: _____ MODEL: _____ AUTO/MANUAL: _____

HYDRAULIC PUMP MAKE: _____ MODEL: _____

FILTERS	MAKE	PART NO.	LUBRICANT	MANUFACTURER TYPE
---------	------	----------	-----------	-------------------

OIL	_____	_____	ENGINE	_____
AIR INNER	_____	_____	TRANSMISSION	_____
AIR OUTER	_____	_____	POWER STEERING	_____
FUEL PRIMARY	_____	_____	HYDRAULIC	_____
FUEL SECONDARY	_____	_____	DIFFERENTIALS	_____
COOLANT	_____	_____	BRAKE FLUID	_____
HYDRAULIC	_____	_____	COOLANT	_____
OTHER	_____	_____	OTHER	_____

State of West Virginia
VENDOR PREFERENCE CERTIFICATE

Certification and application* is hereby made for Preference in accordance with *West Virginia Code*, §5A-3-37. (Does not apply to construction contracts). *West Virginia Code*, §5A-3-37, provides an opportunity for qualifying vendors to request (at the time of bid) preference for their residency status. Such preference is an evaluation method only and will be applied only to the cost bid in accordance with the *West Virginia Code*. This certificate for application is to be used to request such preference. The Purchasing Division will make the determination of the Resident Vendor Preference, if applicable.

1. **Application is made for 2.5% resident vendor preference for the reason checked:**
 Bidder is an individual resident vendor and has resided continuously in West Virginia for four (4) years immediately preceding the date of this certification; or,
 Bidder is a partnership, association or corporation resident vendor and has maintained its headquarters or principal place of business continuously in West Virginia for four (4) years immediately preceding the date of this certification; or 80% of the ownership interest of Bidder is held by another individual, partnership, association or corporation resident vendor who has maintained its headquarters or principal place of business continuously in West Virginia for four (4) years immediately preceding the date of this certification; or,
 Bidder is a nonresident vendor which has an affiliate or subsidiary which employs a minimum of one hundred state residents and which has maintained its headquarters or principal place of business within West Virginia continuously for the four (4) years immediately preceding the date of this certification; or,
2. **Application is made for 2.5% resident vendor preference for the reason checked:**
 Bidder is a resident vendor who certifies that, during the life of the contract, on average at least 75% of the employees working on the project being bid are residents of West Virginia who have resided in the state continuously for the two years immediately preceding submission of this bid; or,
3. **Application is made for 2.5% resident vendor preference for the reason checked:**
 Bidder is a nonresident vendor employing a minimum of one hundred state residents or is a nonresident vendor with an affiliate or subsidiary which maintains its headquarters or principal place of business within West Virginia employing a minimum of one hundred state residents who certifies that, during the life of the contract, on average at least 75% of the employees or Bidder's affiliate's or subsidiary's employees are residents of West Virginia who have resided in the state continuously for the two years immediately preceding submission of this bid; or,
4. **Application is made for 5% resident vendor preference for the reason checked:**
 Bidder meets either the requirement of both subdivisions (1) and (2) or subdivision (1) and (3) as stated above; or,
5. **Application is made for 3.5% resident vendor preference who is a veteran for the reason checked:**
 Bidder is an individual resident vendor who is a veteran of the United States armed forces, the reserves or the National Guard and has resided in West Virginia continuously for the four years immediately preceding the date on which the bid is submitted; or,
6. **Application is made for 3.5% resident vendor preference who is a veteran for the reason checked:**
 Bidder is a resident vendor who is a veteran of the United States armed forces, the reserves or the National Guard, if, for purposes of producing or distributing the commodities or completing the project which is the subject of the vendor's bid and continuously over the entire term of the project, on average at least seventy-five percent of the vendor's employees are residents of West Virginia who have resided in the state continuously for the two immediately preceding years.
7. **Application is made for preference as a non-resident small, women- and minority-owned business, in accordance with *West Virginia Code* §5A-3-59 and *West Virginia Code of State Rules*.**
 Bidder has been or expects to be approved prior to contract award by the Purchasing Division as a certified small, women- and minority-owned business.

Bidder understands if the Secretary of Revenue determines that a Bidder receiving preference has failed to continue to meet the requirements for such preference, the Secretary may order the Director of Purchasing to: (a) reject the bid; or (b) assess a penalty against such Bidder in an amount not to exceed 5% of the bid amount and that such penalty will be paid to the contracting agency or deducted from any unpaid balance on the contract or purchase order.

By submission of this certificate, Bidder agrees to disclose any reasonably requested information to the Purchasing Division and authorizes the Department of Revenue to disclose to the Director of Purchasing appropriate information verifying that Bidder has paid the required business taxes, provided that such information does not contain the amounts of taxes paid nor any other information deemed by the Tax Commissioner to be confidential.

Under penalty of law for false swearing (*West Virginia Code*, §61-5-3), Bidder hereby certifies that this certificate is true and accurate in all respects; and that if a contract is issued to Bidder and if anything contained within this certificate changes during the term of the contract, Bidder will notify the Purchasing Division in writing immediately.

Bidder: Heritage Equipment Inc.

Signed: 

Date: 7-3-13

Title: Sales Manager

RFQ No. 70135014

STATE OF WEST VIRGINIA
Purchasing Division

PURCHASING AFFIDAVIT

MANDATE: Under W. Va. Code §5A-3-10a, no contract or renewal of any contract may be awarded by the state or any of its political subdivisions to any vendor or prospective vendor when the vendor or prospective vendor or a related party to the vendor or prospective vendor is a debtor and: (1) the debt owed is an amount greater than one thousand dollars in the aggregate; or (2) the debtor is in employer default.

EXCEPTION: The prohibition listed above does not apply where a vendor has contested any tax administered pursuant to chapter eleven of the W. Va. Code, workers' compensation premium, permit fee or environmental fee or assessment and the matter has not become final or where the vendor has entered into a payment plan or agreement and the vendor is not in default of any of the provisions of such plan or agreement.

DEFINITIONS:

"Debt" means any assessment, premium, penalty, fine, tax or other amount of money owed to the state or any of its political subdivisions because of a judgment, fine, permit violation, license assessment, defaulted workers' compensation premium, penalty or other assessment presently delinquent or due and required to be paid to the state or any of its political subdivisions, including any interest or additional penalties accrued thereon.

"Employer default" means having an outstanding balance or liability to the old fund or to the uninsured employers' fund or being in policy default, as defined in W. Va. Code § 23-2c-2, failure to maintain mandatory workers' compensation coverage, or failure to fully meet its obligations as a workers' compensation self-insured employer. An employer is not in employer default if it has entered into a repayment agreement with the Insurance Commissioner and remains in compliance with the obligations under the repayment agreement.

"Related party" means a party, whether an individual, corporation, partnership, association, limited liability company or any other form or business association or other entity whatsoever, related to any vendor by blood, marriage, ownership or contract through which the party has a relationship of ownership or other interest with the vendor so that the party will actually or by effect receive or control a portion of the benefit, profit or other consideration from performance of a vendor contract with the party receiving an amount that meets or exceed five percent of the total contract amount.

AFFIRMATION: By signing this form, the vendor's authorized signer affirms and acknowledges under penalty of law for false swearing (W. Va. Code §61-5-3) that neither vendor nor any related party owe a debt as defined above and that neither vendor nor any related party are in employer default as defined above, unless the debt or employer default is permitted under the exception above.

WITNESS THE FOLLOWING SIGNATURE:

Vendor's Name: Heritage Equipment Inc.

Authorized Signature: *Paul Nubland, VP* Date: 7-3-13

State of West Virginia

County of Raleigh, to-wit:

Taken, subscribed, and sworn to before me this 3rd day of July 3, 2013.

My Commission expires October 2, 2022.

AFFIX SEAL HERE

NOTARY PUBLIC

Donna S Johnson

Purchasing Affidavit (Revised 07/01/2012)

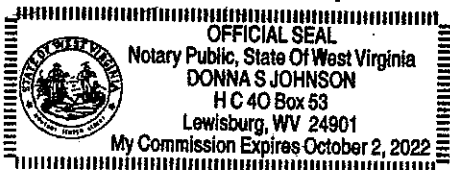

NOTE:

Vendor and Notary's date must be the same.

Notary required to AFFIX SEAL on Purchasing Affidavit.

Prepared for:
ALAN CUMMINGS
STATE OF WEST VIRGINIA
2019 WASHINGTON ST EAST
PO BOX 50130
CHARLESTON, WV 25305
Phone: 304-558-2402

Prepared by:
Bobby Slade
HERITAGE EQUIPMENT, INC.
322 DRY HILL RD.
BECKLEY, WV 25801
Phone: (304) 254-7827

A proposal for
STATE OF WEST VIRGINIA

Prepared by
HERITAGE EQUIPMENT, INC.
Bobby Slade

Jul 01, 2013

Western Star 4700SF

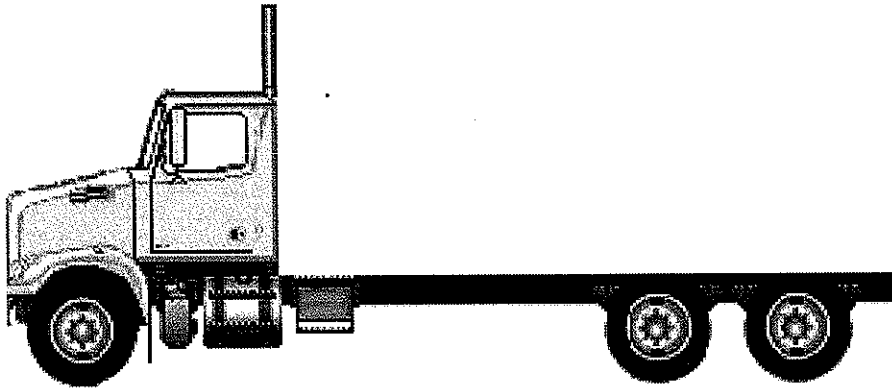

Components shown may not reflect all spec'd options and are not to scale

Prepared for:
 ALAN CUMMINGS
 STATE OF WEST VIRGINIA
 2019 WASHINGTON ST EAST
 PO BOX 50130
 CHARLESTON, WV 25305
 Phone: 304-558-2402

Prepared by:
 Bobby Slade
 HERITAGE EQUIPMENT, INC.
 322 DRY HILL RD.
 BECKLEY, WV 25801
 Phone: (304) 254-7827

S P E C I F I C A T I O N P R O P O S A L

Data Code	Description	Weight Front	Weight Rear	Retail Price
Price Level				
PRL-05T	WESTERN STAR 4700 PRL-05T (EFF:03/8/13)			STD
Data Version				
DRL-016	SPECPRO21 DATA RELEASE VER 016			N/C
Vehicle Configuration				
001-450	WESTERN STAR 4700 SET-FORWARD FRONT AXLE CHASSIS	8,555	6,555	\$130,835.00
004-214	2014 MODEL YEAR SPECIFIED			STD
002-003	SET FORWARD AXLE - TRUCK			STD
019-002	STRAIGHT TRUCK PROVISION			STD
003-001	LH PRIMARY STEERING LOCATION			STD
General Service				
AA1-002	TRUCK CONFIGURATION			STD
AA6-002	DOMICILED, USA (EXCLUDING CALIFORNIA AND CARB OPT-IN STATES)			STD
A85-011	CONSTRUCTION SERVICE			STD
A84-1CO	CONSTRUCTION BUSINESS SEGMENT			STD
AA4-003	DRY BULK COMMODITY			STD
AA5-002	TERRAIN/DUTY: 100% (ALL) OF THE TIME, IN TRANSIT, IS SPENT ON PAVED ROADS			STD
AB1-008	MAXIMUM 8% EXPECTED GRADE			STD
AB5-001	SMOOTH CONCRETE OR ASPHALT PAVEMENT - MOST SEVERE IN-TRANSIT (BETWEEN SITES) ROAD SURFACE			STD
995-1A5	WESTERN STAR VOCATIONAL WARRANTY			STD
A66-99D	EXPECTED FRONT AXLE(S) LOAD : 20000.0 lbs			
A68-99D	EXPECTED REAR DRIVE AXLE(S) LOAD : 40000.0 lbs			
A63-99D	EXPECTED GROSS VEHICLE WEIGHT CAPACITY : 60000.0 lbs			
Truck Service				
AA3-005	FLATBED/PLATFORM/STAKE BODY			N/C



Prepared for:
 ALAN CUMMINGS
 STATE OF WEST VIRGINIA
 2019 WASHINGTON ST EAST
 PO BOX 50130
 CHARLESTON, WV 25305
 Phone: 304-558-2402

Prepared by:
 Bobby Slade
 HERITAGE EQUIPMENT, INC.
 322 DRY HILL RD.
 BECKLEY, WV 25801
 Phone: (304) 254-7827

Data Code	Description	Weight Front	Weight Rear	Retail Price
Engine				
101-2XN	CUM ISL 370 HP @ 2000 RPM, 2100 GOV RPM, 1250 LB/FT @ 1400 RPM			\$3,117.00
Electronic Parameters				
79A-069	69 MPH ROAD SPEED LIMIT			N/C
79B-000	CRUISE CONTROL SPEED LIMIT SAME AS ROAD SPEED LIMIT			N/C
79K-007	PTO MODE ENGINE RPM LIMIT - 1100 RPM			N/C
79P-002	PTO RPM WITH CRUISE SET SWITCH - 700 RPM			N/C
79Q-003	PTO RPM WITH CRUISE RESUME SWITCH - 800 RPM			N/C
79S-001	PTO MODE CANCEL VEHICLE SPEED - 5 MPH			N/C
79U-007	PTO GOVERNOR RAMP RATE - 250 RPM PER SECOND			N/C
80G-002	PTO MINIMUM RPM - 700			N/C
80J-002	REGEN INHIBIT SPEED THRESHOLD - 5 MPH			N/C
Engine Equipment				
99C-013	2013 ONBOARD DIAGNOSTICS/2010 EPA/CARB/GHG14			STD
99D-010	NO 2008 CARB EMISSION CERTIFICATION			STD
13E-001	STANDARD OIL PAN			STD
105-001	ENGINE MOUNTED OIL CHECK AND FILL			STD
133-004	ONE PIECE VALVE COVER			STD
014-099	SIDE OF HOOD AIR INTAKE WITH FIREWALL MOUNTED DONALDSON AIR CLEANER			STD
124-1D7	DR 12V 160 AMP 28-SI QUADRAMOUNT PAD ALTERNATOR WITH REMOTE BATTERY VOLT SENSE			STD
292-071	(3) ALLIANCE MODEL 1231, GROUP 31, 12 VOLT MAINTENANCE FREE 3375 CCA THREADED STUD BATTERIES	-10		(\$191.00)
290-017	BATTERY BOX FRAME MOUNTED	35		\$135.00
282-003	SINGLE BATTERY BOX FRAME MOUNTED LH SIDE BACK OF CAB			N/C
291-017	WIRE GROUND RETURN FOR BATTERY CABLES WITH ADDITIONAL FRAME GROUND RETURN			STD
289-001	NON-POLISHED BATTERY BOX COVER			N/C
293-058	POSITIVE LOAD DISCONNECT WITH CAB MOUNTED CONTROL SWITCH MOUNTED OUTBOARD DRIVER SEAT	8		\$155.00



Prepared for:
 ALAN CUMMINGS
 STATE OF WEST VIRGINIA
 2019 WASHINGTON ST EAST
 PO BOX 50130
 CHARLESTON, WV 25305
 Phone: 304-558-2402

Prepared by:
 Bobby Slade
 HERITAGE EQUIPMENT, INC.
 322 DRY HILL RD.
 BECKLEY, WV 25801
 Phone: (304) 254-7827

Data Code	Description	Weight Front	Weight Rear	Retail Price
295-029	POSITIVE AND NEGATIVE POSTS FOR JUMPSTART LOCATED ON FRAME NEXT TO STARTER	2		\$157.00
107-032	CUMMINS TURBOCHARGED 18.7 CFM AIR COMPRESSOR WITH INTERNAL SAFETY VALVE			STD
131-013	AIR COMPRESSOR DISCHARGE LINE			STD
152-041	ELECTRONIC ENGINE INTEGRAL SHUTDOWN PROTECTION SYSTEM			STD
128-076	CUMMINS EXHAUST BRAKE INTEGRAL WITH VARIABLE GEOMETRY TURBO WITH ON/OFF DASH SWITCH			\$14.00
016-1C2	RH OUTBOARD UNDER STEP MOUNTED HORIZONTAL AFTERTREATMENT SYSTEM ASSEMBLY WITH RH B-PILLAR MOUNTED VERTICAL TAILPIPE			STD
28F-002	ENGINE AFTERTREATMENT DEVICE, AUTOMATIC OVER THE ROAD REGENERATION AND DASH MOUNTED REGENERATION REQUEST SWITCH			STD
239-032	11 FOOT 00 INCH (132 INCH+0/-5 INCH) EXHAUST SYSTEM HEIGHT			N/C
237-1CR	RH CURVED VERTICAL TAILPIPE B-PILLAR MOUNTED ROUTED FROM STEP			STD
23U-002	13 GALLON DIESEL EXHAUST FLUID TANK	40	20	(\$93.00)
23Y-001	STANDARD DIESEL EXHAUST FLUID PUMP MOUNTING			STD
43X-001	LH HEAVY DUTY STANDARD DIESEL EXHAUST FLUID TANK LOCATION			N/C
242-001	STAINLESS STEEL AFTERTREATMENT DEVICE/MUFFLER/TAILOPIPE SHIELD			STD
273-018	HORTON DRIVEMASTER ON/OFF FAN DRIVE			STD
276-002	AUTOMATIC FAN CONTROL WITH DASH SWITCH AND INDICATOR LIGHT, NON ENGINE MOUNTED			\$31.00
110-003	CUMMINS SPIN ON FUEL FILTER			STD
118-008	COMBINATION FULL FLOW/BYPASS OIL FILTER			STD
266-017	1300 SQUARE INCH ALUMINUM RADIATOR			STD
267-006	MOUNTING FOR FIREWALL MOUNTED SURGE TANK			STD
103-004	ANTIFREEZE TO -34F, NOAT EXTENDED LIFE COOLANT			STD
171-007	GATES BLUE STRIPE COOLANT HOSES OR EQUIVALENT			STD
172-001	CONSTANT TENSION HOSE CLAMPS FOR COOLANT HOSES			STD



Prepared for:
 ALAN CUMMINGS
 STATE OF WEST VIRGINIA
 2019 WASHINGTON ST EAST
 PO BOX 50130
 CHARLESTON, WV 25305
 Phone: 304-558-2402

Prepared by:
 Bobby Slade
 HERITAGE EQUIPMENT, INC.
 322 DRY HILL RD.
 BECKLEY, WV 25801
 Phone: (304) 254-7827

Data Code	Description	Weight Front	Weight Rear	Retail Price
270-016	RADIATOR DRAIN VALVE			STD
138-011	PHILLIPS-TEMRO 1000 WATT/115 VOLT BLOCK HEATER	4		\$88.00
140-022	CHROME ENGINE HEATER RECEPTACLE MOUNTED UNDER LH DOOR			N/C
134-001	ALUMINUM FLYWHEEL HOUSING			STD
132-004	ELECTRIC GRID AIR INTAKE WARMER			STD
155-058	DELCO 12V 38MT HD STARTER WITH INTEGRATED MAGNETIC SWITCH			STD
Transmission				
342-582	ALLISON 3000 RDS AUTOMATIC TRANSMISSION WITH PTO PROVISION	-110	-35	\$9,697.00
Transmission Equipment				
343-019	WTEC CALIBRATION - 6 SPEED RDS/TRV (PACKAGE 113)			N/C
362-035	CUSTOMER INSTALLED CHELSEA 277 SERIES PTO			N/C
363-001	PTO MOUNTING, LH SIDE OF MAIN TRANSMISSION			N/C
341-018	MAGNETIC PLUGS, ENGINE DRAIN, TRANSMISSION DRAIN, AXLE(S) FILL AND DRAIN			N/C
345-003	PUSH BUTTON ELECTRONIC SHIFT CONTROL, DASH MOUNTED			N/C
97G-005	TRANSMISSION PROGNOSTICS - DISABLED(N/A) 2013			N/C
370-015	WATER TO OIL TRANSMISSION COOLER, IN RADIATOR END TANK			N/C
346-003	TRANSMISSION OIL CHECK AND FILL WITH ELECTRONIC OIL LEVEL CHECK			N/C
35T-001	SYNTHETIC TRANSMISSION FLUID (TES-295 COMPLIANT)			N/C
Front Axle and Equipment				
400-1AC	MFS-20-133A 20,000# FL1 SINGLE FRONT AXLE	60		\$1,549.00
389-998	NO FRONT AXLE DRIVESHAFT			STD
402-030	MERITOR 16.5X6 Q+ CAST SPIDER CAM FRONT BRAKES, DOUBLE ANCHOR, FABRICATED SHOES			STD
403-002	NON-ASBESTOS FRONT BRAKE LINING			STD
419-023	CONMET CAST IRON FRONT BRAKE DRUMS			STD
409-021	SKF SCOTSEAL PLUS XL FRONT OIL SEALS			STD
408-001	VENTED FRONT HUB CAPS WITH WINDOW, CENTER AND SIDE PLUGS - OIL			STD



Prepared for:
 ALAN CUMMINGS
 STATE OF WEST VIRGINIA
 2019 WASHINGTON ST EAST
 PO BOX 50130
 CHARLESTON, WV 25305
 Phone: 304-558-2402

Prepared by:
 Bobby Slade
 HERITAGE EQUIPMENT, INC.
 322 DRY HILL RD.
 BECKLEY, WV 25801
 Phone: (304) 254-7827

Data Code	Description	Weight Front	Weight Rear	Retail Price
416-022	STANDARD SPINDLE NUTS FOR ALL AXLES			STD
405-002	MERITOR AUTOMATIC FRONT SLACK ADJUSTERS			(\$61.00)
406-001	STANDARD KING PIN BUSHINGS			STD
536-055	TRW THP-60 POWER STEERING WITH RCH45 AUXILIARY GEAR	90		N/C
539-003	POWER STEERING PUMP			STD
534-003	4 QUART POWER STEERING RESERVOIR			N/C
533-001	OIL/AIR POWER STEERING COOLER			N/C
40T-003	SYNTHETIC 50W FRONT AXLE LUBE			STD
Front Suspension				
620-006	20,000# FLAT LEAF FRONT SUSPENSION	50		\$147.00
619-002	THREADED SPRING PINS AND BUSHINGS - FRONT SUSPENSION			\$237.00
410-001	FRONT SHOCK ABSORBERS			\$135.00
Rear Axle and Equipment				
420-1K3	MT-40-14X 40,000# R-SERIES TANDEM REAR AXLE			STD
421-529	5.29 REAR AXLE RATIO			N/C
424-003	IRON REAR AXLE CARRIER WITH OPTIONAL HEAVY DUTY AXLE HOUSING			STD
386-074	MXL 176T MERITOR EXTENDED LUBE MAIN DRIVELINE WITH HALF ROUND YOKES	30	30	\$477.00
388-073	MXL 17T MERITOR EXTENDED LUBE INTERAXLE DRIVELINE WITH HALF ROUND YOKES			STD
452-006	DRIVER CONTROLLED TRACTION DIFFERENTIAL - BOTH TANDEM REAR AXLES		30	\$1,390.00
878-022	(1) INTERAXLE LOCK VALVE, (1) DRIVER CONTROLLED DIFFERENTIAL LOCK FORWARD-REAR AXLE VALVE AND (1) REAR-REAR AXLE VALVE			\$42.00
87A-005	INDICATOR LIGHT FOR EACH INTERAXLE LOCKOUT SWITCH			STD
87B-008	INDICATOR LIGHT FOR EACH DRIVER CONTROLLED TRACTION DEVICE SWITCH			N/C
423-020	MERITOR 16.5X7 Q+ CAST SPIDER CAM REAR BRAKES, DOUBLE ANCHOR, FABRICATED SHOES			STD
433-002	NON-ASBESTOS REAR BRAKE LINING			STD
434-003	STANDARD BRAKE CHAMBER LOCATION			N/C
451-023	CONMET CAST IRON REAR BRAKE DRUMS			STD
440-021	SKF SCOTSEAL PLUS XL REAR OIL SEALS			STD



Prepared for:
 ALAN CUMMINGS
 STATE OF WEST VIRGINIA
 2019 WASHINGTON ST EAST
 PO BOX 50130
 CHARLESTON, WV 25305
 Phone: 304-558-2402

Prepared by:
 Bobby Slade
 HERITAGE EQUIPMENT, INC.
 322 DRY HILL RD.
 BECKLEY, WV 25801
 Phone: (304) 254-7827

Data Code	Description	Weight Front	Weight Rear	Retail Price
426-075	HALDEX GOLDSEAL LONGSTROKE 2-DRIVE AXLES SPRING PARKING CHAMBERS			STD
428-003	HALDEX AUTOMATIC REAR SLACK ADJUSTERS			STD
41T-002	SYNTHETIC 75W-90 REAR AXLE LUBE			STD
Rear Suspension				
622-1CH	HENDRICKSON RT403 REAR SUSPENSION @ 40,000#		390	(\$348.00)
621-016	HENDRICKSON RT/RTE - 7.19" SADDLE			N/C
431-001	STANDARD U-BOLT PAD			N/C
624-011	52 INCH AXLE SPACING			N/C
628-004	STEEL BEAMS AND RUBBER CENTER BUSHINGS WITH BAR PIN ADJUSTABLE END CONNECTIONS			N/C
623-005	FORE/AFT CONTROL RODS			N/C
Brake System				
490-100	WABCO 4S/4M ABS WITHOUT TRACTION CONTROL			STD
871-001	REINFORCED NYLON, FABRIC BRAID AND WIRE BRAID CHASSIS AIR LINES			STD
904-001	FIBER BRAID PARKING BRAKE HOSE			STD
412-001	STANDARD BRAKE SYSTEM VALVES			STD
432-003	RELAY VALVE WITH 5-8 PSI CRACK PRESSURE, NO REAR PROPORTIONING VALVE			STD
480-034	BW AD-IP BRAKE LINE AIR DRYER WITH HEATER	5		N/C
483-003	BENDIX OIL COALESCING FILTER FOR AIR DRYER			N/C
479-003	AIR DRYER MOUNTED INBOARD ON LH RAIL			STD
460-095	STEEL AIR BRAKE RESERVOIRS MOUNTED PERPENDICULAR RH UNDER CAB			STD
477-001	PULL CABLE ON WET TANK, PETCOCK DRAIN VALVES ON ALL OTHER AIR TANKS			STD
Trailer Connections				
310-998	NO TRAILER ELECTRICAL CABLE			STD
Wheelbase & Frame				
545-607	6075MM (239 INCH) WHEELBASE			N/C
546-101	11/32X3-1/2X10-15/16 INCH STEEL FRAME (8.73MMX277.8MM/0.344X10.94 INCH) 120KSI	340		\$473.00
547-001	1/4 INCH (6.35MM) C-CHANNEL INNER FRAME REINFORCEMENT	187	403	\$988.00
552-018	1625MM (64 INCH) REAR FRAME OVERHANG			N/C



Prepared for:
 ALAN CUMMINGS
 STATE OF WEST VIRGINIA
 2019 WASHINGTON ST EAST
 PO BOX 50130
 CHARLESTON, WV 25305
 Phone: 304-558-2402

Prepared by:
 Bobby Slade
 HERITAGE EQUIPMENT, INC.
 322 DRY HILL RD.
 BECKLEY, WV 25801
 Phone: (304) 254-7827

Data Code	Description	Weight Front	Weight Rear	Retail Price
55W-006	FRAME OVERHANG RANGE: 61 INCH TO 70 INCH	-20	70	N/C
AC8-99D	CALC'D BACK OF CAB TO REAR SUSP C/L (CA) : 157.78 in			
AE8-99D	CALCULATED EFFECTIVE BACK OF CAB TO REAR SUSPENSION C/L (CA) : 154.78 in			
AE4-99D	CALC'D FRAME LENGTH - OVERALL : 319.97			
AM6-99D	CALC'D SPACE AVAILABLE FOR DECKPLATE : 157.78 in			
FSS-0LH	FRAME SPACE LH SIDE : 97.84 in			N/C
FSS-0RH	FRAME SPACE RH SIDE : 127.78 in			N/C
553-001	SQUARE END OF FRAME			STD
559-001	STANDARD WEIGHT ENGINE CROSSMEMBER			STD
562-001	STANDARD MIDSHIP #1 CROSSMEMBER(S)			STD
572-001	STANDARD REARMOST CROSSMEMBER			STD
565-002	HEAVY DUTY SUSPENSION CROSSMEMBER			STD
568-001	STANDARD WEIGHT REAR SUSPENSION CROSSMEMBER			STD

Chassis Equipment

556-1EE	16 INCH PAINTED STEEL BUMPER			STD
558-033	REMOVABLE FRONT TOW HOOKS STORED ON THE CHASSIS FRAME	25		\$98.00
574-001	BUMPER MOUNTING FOR SINGLE LICENSE PLATE			STD
585-998	NO MUDFLAP BRACKETS			STD
590-998	NO REAR MUDFLAPS			STD
586-015	FRONT ANTI-SPRAY CAB MOUNTED MUDFLAPS			STD
551-007	GRADE 8 THREADED HEX HEADED FRAME FASTENERS			STD
609-998	NO STORAGE BOX BRIGHTWORK			STD

Fifth Wheel

578-998	NO FIFTH WHEEL			STD
---------	----------------	--	--	-----

Fuel Tanks

204-151	60 GALLON/227 LITER ALUMINUM FUEL TANK - LH			STD
218-006	25 INCH DIAMETER FUEL TANK(S)			STD
215-005	PLAIN ALUMINUM/PAINTED STEEL FUEL/HYDRAULIC TANK(S) WITH PAINTED BANDS			STD
212-007	FUEL TANK(S) FORWARD			STD
664-001	PLAIN STEP FINISH			STD



Prepared for:
 ALAN CUMMINGS
 STATE OF WEST VIRGINIA
 2019 WASHINGTON ST EAST
 PO BOX 50130
 CHARLESTON, WV 25305
 Phone: 304-558-2402

Prepared by:
 Bobby Slade
 HERITAGE EQUIPMENT, INC.
 322 DRY HILL RD.
 BECKLEY, WV 25801
 Phone: (304) 254-7827

Data Code	Description	Weight Front	Weight Rear	Retail Price
205-001	FUEL TANK CAP(S)			STD
122-075	ALLIANCE FUEL FILTER/WATER SEPARATOR			STD
216-020	EQUIFLO INBOARD FUEL SYSTEM			STD
202-016	HIGH TEMPERATURE REINFORCED NYLON FUEL LINE			STD
Tires				
093-0TC	MICHELIN XZY-3 445/65R22.5 20 PLY RADIAL FRONT TIRES	232		\$1,564.00
094-0DJ	MICHELIN XDE M/S 11R22.5 16 PLY RADIAL REAR TIRES		88	\$1,680.00
529-998	TIRE QTY - PUSHER AXLE: 0			N/C
530-998	TIRE QTY - TAG AXLE: 0			N/C
Hubs				
418-045	CONMET PRE-SET BEARING IRON FRONT HUBS			STD
450-045	CONMET PRE-SET BEARING IRON REAR HUBS			STD
Wheels				
502-574	ACCURIDE 29807 22.5X12.25 10-HUB PILOT 4.75 INSET 5-HAND STEEL DISC FRONT WHEELS	82		\$350.00
505-428	ACCURIDE 28828 22.5X8.25 10-HUB PILOT 2-HAND HD STEEL DISC REAR WHEELS		40	STD
496-011	FRONT WHEEL MOUNTING NUTS			STD
497-011	REAR WHEEL MOUNTING NUTS			STD
Cab Exterior				
829-1A8	110 INCH BBC STEEL CONVENTIONAL CAB			STD
682-998	NO SLEEPER BOX/SLEEPER CAB			STD
82A-023	WESTERN STAR PAINTED ALUMINUM CAB SKIRT			STD
650-008	AIR CAB MOUNTS			STD
648-002	NONREMOVABLE BUGSCREEN MOUNTED BEHIND GRILLE			STD
667-001	FRONT FENDERS			STD
754-001	2 INCH FENDER EXTENSIONS	5		\$210.00
678-009	LH AND RH EXTERIOR GRAB HANDLES AND RH INTERIOR GRAB HANDLE MOUNTED TO A POST			STD
646-008	STATIONARY BRIGHT FINISH GRILLE			STD
65X-003	CHROMED HOOD MOUNTED AIR INTAKE GRILLE			STD
640-009	HEAVY DUTY STEEL CAB FLOOR			(\$326.00)
644-004	FIBERGLASS HOOD			STD



Prepared for:
 ALAN CUMMINGS
 STATE OF WEST VIRGINIA
 2019 WASHINGTON ST EAST
 PO BOX 50130
 CHARLESTON, WV 25305
 Phone: 304-558-2402

Prepared by:
 Bobby Slade
 HERITAGE EQUIPMENT, INC.
 322 DRY HILL RD.
 BECKLEY, WV 25801
 Phone: (304) 254-7827

Data Code	Description	Weight Front	Weight Rear	Retail Price
690-007	HOOD LINER INSULATION WITH SINGLE FIREWALL INSULATION			\$159.00
727-019	SINGLE HADLEY SD-978 26 INCH RECTANGULAR AIR HORN	-4		(\$129.00)
726-001	SINGLE ELECTRIC HORN			STD
728-001	SINGLE HORN SHIELD			N/C
657-1AF	DOORS AND IGNITION KEYED THE SAME (3 KEYS)			\$7.00
575-001	REAR LICENSE PLATE MOUNT END OF FRAME			STD
312-072	SINGLE RECTANGULAR SEALED BEAM HEADLIGHTS WITH BRIGHT BEZELS			STD
302-001	(5) AMBER MARKER LIGHTS			STD
294-001	INTEGRAL STOP/TAIL/BACKUP LIGHTS			STD
300-015	STANDARD FRONT TURN SIGNAL LAMPS			STD
744-1E0	DUAL WEST COAST STAINLESS STEEL HEATED MIRRORS WITH LH AND RH REMOTE			\$413.00
797-001	DOOR MOUNTED MIRRORS			STD
796-001	102 INCH EQUIPMENT WIDTH			STD
743-1AC	LH AND RH 8 INCH STAINLESS STEEL CONVEX MIRRORS MOUNTED BELOW PRIMARY MIRRORS			STD
74A-001	RH DOWN VIEW MIRROR			STD
729-001	STANDARD SIDE/REAR REFLECTORS			STD
787-020	ELECTRIC DOOR LOCKS, MECHANICAL KEY TUMBLER			\$190.00
768-046	17.5X35 INCH TINTED REAR WINDOW			STD
661-006	TINTED DOOR GLASS			STD
654-011	RH AND LH ELECTRIC POWERED WINDOWS	4		\$264.00
663-014	2-PIECE TINTED CURVED BONDED WINDSHIELD			(\$49.00)
659-016	1.5 GALLON WINDSHIELD WASHER RESERVOIR MOUNTED UNDER CAB WITH REMOTE FILL			STD

Cab Interior

707-1D4	SMOKY MOUNTAIN GRAY VINYL PREMIUM INTERIOR			\$184.00
70K-005	BLACK HARD TRIM			STD
706-049	BASE LEFT HAND DOOR TRIM			STD
708-049	BASE RIGHT HAND DOOR TRIM			STD
772-007	BLACK MATS WITH DOUBLE INSULATION			N/C
785-016	DASH MOUNTED ASH TRAY AND (1) POWER OUTLET			N/C
691-001	FORWARD ROOF MOUNTED CONSOLE			STD



Prepared for:
 ALAN CUMMINGS
 STATE OF WEST VIRGINIA
 2019 WASHINGTON ST EAST
 PO BOX 50130
 CHARLESTON, WV 25305
 Phone: 304-558-2402

Prepared by:
 Bobby Slade
 HERITAGE EQUIPMENT, INC.
 322 DRY HILL RD.
 BECKLEY, WV 25801
 Phone: (304) 254-7827

Data Code	Description	Weight Front	Weight Rear	Retail Price
694-009	PASSENGER SIDE WING DASH MOUNTED GLOVE BOX WITH LOCKING DOOR			STD
693-025	LH AND RH DOOR MAP POCKETS			STD
741-029	COAT HOOK ON RH BACKWALL OF CAB			STD
742-032	(1) DOUBLE CUP HOLDER WITH CELL PHONE HOLDER LH OR RH DASH			\$31.00
680-034	TWO-TONE CHARCOAL UPPER/COOL GRAY LOWER SOFT TOUCH WING DASH WITH BLACK DRIVER SIDE COSMETIC UNDER DASH COVER			STD
320-004	STANDARD WIRING			STD
720-003	5 LB. FIRE EXTINGUISHER	10		\$65.00
700-015	HEATER, DEFROSTER AND AIR CONDITIONER WITH COSMETIC COVER			STD
701-010	HVAC DUCTING WITH FOAM MAIN FRESH AIR FILTER AND OUTSIDE PRE-FILTER			STD
703-005	MAIN HVAC CONTROLS WITH RECIRCULATION SWITCH			STD
170-019	STANDARD HEATER PLUMBING WITH BALL SHUTOFF VALVES			\$33.00
130-033	DENSO HEAVY DUTY AIR CONDITIONER COMPRESSOR			STD
698-001	RADIATOR MOUNTED AIR CONDITIONER CONDENSER			STD
702-002	BINARY CONTROL, R-134A			STD
739-002	ADDITIONAL CAB SIDEWALL INSULATION	60	10	\$162.00
285-003	CIRCUIT FUSES			STD
324-076	DOOR ACTIVATED DOME LIGHT, UNDER DASH LIGHT WITH LH AND RH DOOR MOUNTED COURTESY LIGHTS AND LH AND RH READING LIGHTS			\$61.00
655-005	LH AND RH ELECTRIC DOOR LOCKS			N/C
284-023	(1) 12 VOLT POWER SUPPLY IN DASH			\$107.00
* 756-1G5	PREMIUM HIGH BACK AIR SUSPENSION DRIVER SEAT WITH 3 CHAMBER AIR LUNBAR, INTEGRATED CUSHION EXTENSION, FOWARD AND REAR CUSHION TILT, ACTIVE CUSHION & BOLSTER			\$459.00
760-1DD	BASIC HIGH BACK AIR SUSPENSION PASSENGER SEAT WITH 1 CHAMBER AIR LUMBAR, INTEGRATED CUSHION EXTENSION AND REAR CUSHION TILT	-20		(\$545.00)
758-022	BLACK MORDURA CLOTH DRIVER SEAT COVER			STD
761-023	BLACK MORDURA CLOTH PASSENGER SEAT COVER			STD



Prepared for:
 ALAN CUMMINGS
 STATE OF WEST VIRGINIA
 2019 WASHINGTON ST EAST
 PO BOX 50130
 CHARLESTON, WV 25305
 Phone: 304-558-2402

Prepared by:
 Bobby Slade
 HERITAGE EQUIPMENT, INC.
 322 DRY HILL RD.
 BECKLEY, WV 25801
 Phone: (304) 254-7827

Data Code	Description	Weight Front	Weight Rear	Retail Price
763-003	3 POINT DRIVER AND PASSENGER SEAT BELT RETRACTORS			STD
532-002	ADJUSTABLE TILT AND TELESCOPING STEERING COLUMN			STD
540-020	2-SPOKE 18 INCH (450MM) BLACK STEERING WHEEL(S)			N/C
765-002	DRIVER AND PASSENGER INTERIOR SUN VISORS			STD
Instruments & Controls				
185-004	STANDARD FOOT PEDAL SYSTEM			STD
870-004	STAR GAUGES WITH BLACK BEZELS			STD
732-001	BLACK DRIVER INSTRUMENT PANEL			STD
734-001	BLACK CENTER INSTRUMENT PANEL			STD
486-001	LOW AIR PRESSURE LIGHT AND BUZZER			STD
838-001	(1) SINGLE BRAKE APPLICATION AIR GAUGE			\$36.00
840-002	2 INCH PRIMARY AND SECONDARY AIR PRESSURE GAUGES			STD
198-003	DASH MOUNTED AIR RESTRICTION INDICATOR WITH GRADUATIONS			\$53.00
721-001	97 DB BACKUP ALARM		3	\$71.00
149-012	CRUISE CONTROL SWITCHES IN THE CENTER PANEL			STD
156-007	KEY OPERATED IGNITION SWITCH AND INTEGRAL START POSITION; 4 POSITION OFF/RUN/START/ACCESSORY			STD
811-1AJ	DATASTAR DRIVER DISPLAY AND WARNING LAMP/LIGHT BAR DISPLAY, NON-DATA LINKED			\$237.00
160-025	DIAGNOSTIC INTERFACE CONNECTOR, 9 PIN, SAE J1939, LOCATED BELOW DASH			STD
844-001	2 INCH ELECTRIC FUEL GAUGE			STD
148-003	PROGRAMMABLE RPM CONTROL - ELECTRONIC ENGINE			STD
856-001	ELECTRICAL ENGINE COOLANT TEMPERATURE GAUGE			STD
864-001	2 INCH TRANSMISSION OIL TEMPERATURE GAUGE			STD
49B-998	NO VEHICLE STABILITY ADVISOR OR CONTROL			STD
852-002	ELECTRIC ENGINE OIL PRESSURE GAUGE			STD
746-1A2	AM/FM/WB RADIO WITH FRONT AUXILIARY INPUT	10		\$281.00
747-002	ROOF/OVERHEAD CONSOLE MOUNTED RADIO			N/C
750-004	(4) RADIO SPEAKERS IN CAB			N/C



Prepared for:
 ALAN CUMMINGS
 STATE OF WEST VIRGINIA
 2019 WASHINGTON ST EAST
 PO BOX 50130
 CHARLESTON, WV 25305
 Phone: 304-558-2402

Prepared by:
 Bobby Slade
 HERITAGE EQUIPMENT, INC.
 322 DRY HILL RD.
 BECKLEY, WV 25801
 Phone: (304) 254-7827

Data Code	Description	Weight Front	Weight Rear	Retail Price
748-026	POWER AND GROUND WIRING FOR CB RADIO IN OVERHEAD CONSOLE			STD
752-017	MULTI-BAND AM/FM/WB/CB LH MIRROR MOUNTED ANTENNA SYSTEM			STD
810-042	ELECTRONIC MPH SPEEDOMETER WITH SECONDARY KPH SCALE, WITH ODOMETER			STD
817-001	STANDARD VEHICLE SPEED SENSOR			STD
812-001	ELECTRONIC 3000 RPM TACHOMETER			STD
162-002	IGNITION SWITCH CONTROLLED ENGINE STOP			STD
836-001	2 INCH VOLTMETER			STD
660-001	SINGLE ELECTRIC WINDSHIELD WIPER MOTOR WITH DELAY AND ARCTIC TYPE BLADES			\$22.00
304-015	CAB/TRAILER MARKER LIGHT SWITCH WITH SEPARATE HEADLIGHT SWITCH			STD
882-009	ONE VALVE PARKING BRAKE SYSTEM WITH WARNING INDICATOR			STD
299-026	VSM NON CANCELING TURN SIGNAL SWITCH WITH INTEGRAL HEADLAMP DIMMER WITH BRAKE OVERRIDE			STD
298-036	PACIFIC INSIGHT ELECTRONIC FLASHER			STD
Design				
065-000	PAINT: ONE SOLID COLOR			STD
Color				
980-8FC	CAB COLOR A: HSB905935 WHITE PPG BASE/CLEAR			STD
96J-001	CAB INTERIOR PAINTED SAME AS CAB COLOR			STD
986-020	BLACK, HIGH SOLIDS POLYURETHANE CHASSIS PAINT			STD
962-970	VENDOR WHITE FRONT WHEELS/RIMS (PW, TKWHT21, W, TW)			STD
966-970	VENDOR WHITE REAR WHEELS/RIMS (PW, TKWHT21, W, TW)			STD
964-993	BUMPER PAINTED SAME AS CHASSIS			STD
Certification / Compliance				
996-001	U.S. FMVSS CERTIFICATION, EXCEPT SALES CABS AND GLIDER KITS			STD
Sales Programs				
NO SALES PROGRAMS HAVE BEEN SELECTED				

T O T A L V E H I C L E S U M M A R Y



Prepared for:
 ALAN CUMMINGS
 STATE OF WEST VIRGINIA
 2019 WASHINGTON ST EAST
 PO BOX 50130
 CHARLESTON, WV 25305
 Phone: 304-558-2402

Prepared by:
 Bobby Slade
 HERITAGE EQUIPMENT, INC.
 322 DRY HILL RD.
 BECKLEY, WV 25801
 Phone: (304) 254-7827

Adjusted List Price

Adjusted List Price ** \$154,662.00

Weight Summary

	Weight Front	Weight Rear	Total Weight
Factory Weight ⁺	9670 lbs	7604 lbs	17274 lbs
Dealer Installed Options	0 lbs	0 lbs	0 lbs
Total Weight⁺	9670 lbs	7604 lbs	17274 lbs

ITEMS NOT INCLUDED IN ADJUSTED LIST PRICE

Other Factory Charges

PMR-210	2010 ENGINE EMISSIONS ESCALATOR	\$7,300.00
PMT-013	2013 OBD/2010 EPA/CARB/GHG14 ESCALATOR	\$1,085.00
	DELIVERY & ORDER PROCESSING CHARGE	\$1,975.00

Dealer Installed Options

		Weight Front	Weight Rear	Price
001	3 - COPIES MATIANCE MANUALS	0	0	\$90.00
002	3 - CD ROME SERVICE-SHOP MANUALS	0	0	\$630.00
003	3 - CD ROME PARTS MANUALS	0	0	\$630.00
Total Dealer Installed Options		0 lbs	0 lbs	\$1,350.00

(+) Weights shown are estimates only.

If weight is critical, contact Customer Application Engineering.

(**) Prices shown do not include taxes, fees, etc... "Net Equipment Selling Price" is located on the Quotation Details Proposal Report.



Prepared for:
 ALAN CUMMINGS
 STATE OF WEST VIRGINIA
 2019 WASHINGTON ST EAST
 PO BOX 50130
 CHARLESTON, WV 25305
 Phone: 304-558-2402

Prepared by:
 Bobby Slade
 HERITAGE EQUIPMENT, INC.
 322 DRY HILL RD.
 BECKLEY, WV 25801
 Phone: (304) 254-7827

Q U O T A T I O N

WESTERN STAR 4700 SET-FORWARD FRONT AXLE CHASSIS

SET FORWARD AXLE - TRUCK CUM ISL 370 HP @ 2000 RPM, 2100 GOV RPM, 1250 LB/FT @ 1400 RPM ALLISON 3000 RDS AUTOMATIC TRANSMISSION WITH PTO PROVISION MT-40-14X 40,000# R-SERIES TANDEM REAR AXLE HENDRICKSON RT403 REAR SUSPENSION @ 40,000# MFS-20-133A 20,000# FL1 SINGLE FRONT AXLE 20,000# FLAT LEAF FRONT SUSPENSION	110 INCH BBC STEEL CONVENTIONAL CAB NO SLEEPER BOX/SLEEPERCAB 6075MM (239 INCH) WHEELBASE NO FIFTH WHEEL 11/32X3-1/2X10-15/16 INCH STEEL FRAME (8.73MMX277.8MM/0.344X10.94 INCH) 120KSI 1625MM (64 INCH) REAR FRAME OVERHANG 1/4 INCH (6.35MM) C-CHANNEL INNER FRAME REINFORCEMENT
---	--

			PER UNIT		TOTAL
VEHICLE PRICE	TOTAL # OF UNITS (1)	\$	96,252	\$	96,252
EXTENDED WARRANTY		\$	0	\$	0
DEALER INSTALLED OPTIONS		\$	1,350	\$	1,350
CUSTOMER PRICE BEFORE TAX		\$	97,602	\$	97,602

TAXES AND FEES

TAXES AND FEES	\$	0	\$	0
OTHER CHARGES	\$	0	\$	0

TRADE-IN

TRADE-IN ALLOWANCE	\$	(0)	\$	(0)
--------------------	----	-----	----	-----

BALANCE DUE	(LOCAL CURRENCY)	\$	97,602	\$	97,602
-------------	------------------	----	--------	----	--------

COMMENTS: Projected delivery on ___ / ___ / ___ provided the order is received before ___ / ___ / ___.
 APPROVAL: Please indicate your acceptance of this quotation by signing below: Customer:
 X_____ Date: ___ / ___ / ___.



Prepared for:
 ALAN CUMMINGS
 STATE OF WEST VIRGINIA
 2019 WASHINGTON ST EAST
 PO BOX 50130
 CHARLESTON, WV 25305
 Phone: 304-558-2402

Prepared by:
 Bobby Slade
 HERITAGE EQUIPMENT, INC.
 322 DRY HILL RD.
 BECKLEY, WV 25801
 Phone: (304) 254-7827

SHIFT CHART

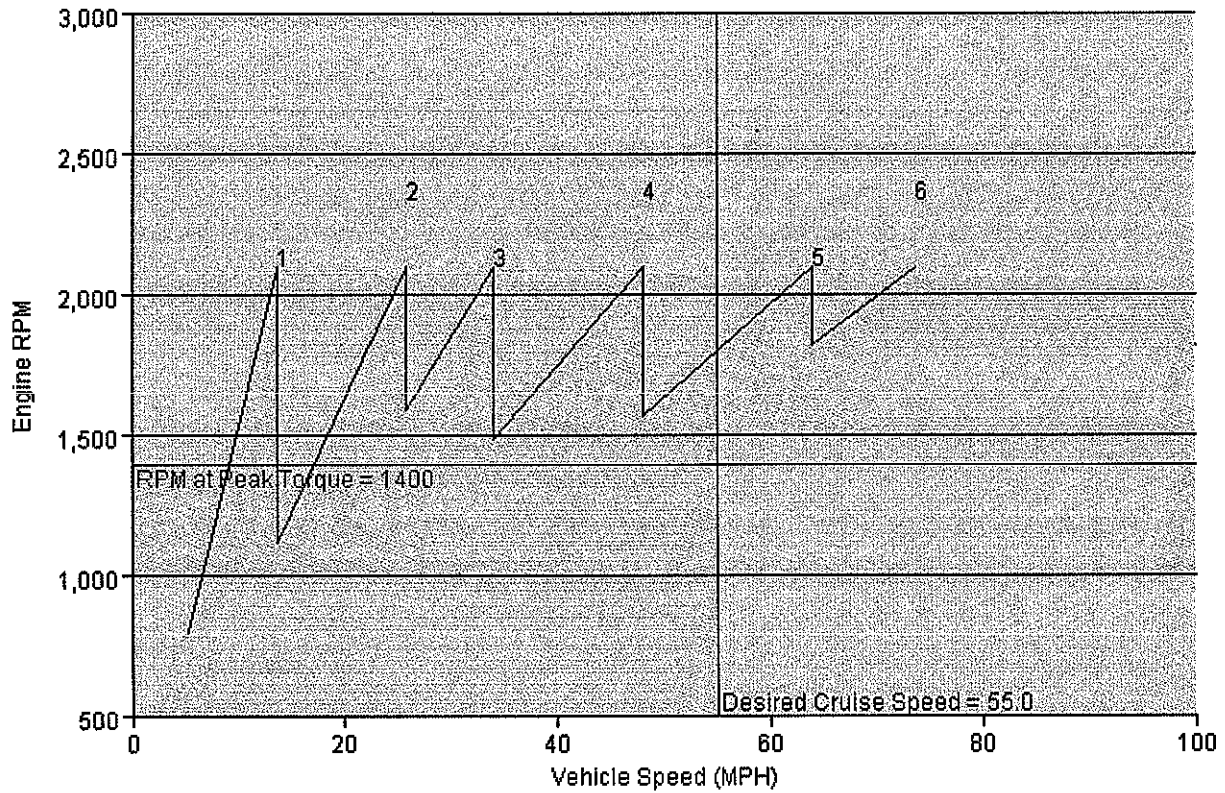

VEHICLE SPECIFICATIONS SUMMARY - SHIFT CHART

Model.....	4700SF
Cab Size (829).....	110 INCH BBC STEEL CONVENTIONAL CAB
Desired Cruise Speed (mph).....	55.0
Engine (101).....	CUM ISL 370 HP @ 2000 RPM, 2100 GOV RPM, 1250 LB/FT @ 1400 RPM
RPM at Peak Torque.....	1400
Governed RPM.....	2100



Prepared for:
 ALAN CUMMINGS
 STATE OF WEST VIRGINIA
 2019 WASHINGTON ST EAST
 PO BOX 50130
 CHARLESTON, WV 25305
 Phone: 304-558-2402

Prepared by:
 Bobby Slade
 HERITAGE EQUIPMENT, INC.
 322 DRY HILL RD.
 BECKLEY, WV 25801
 Phone: (304) 254-7827

Transmission (342) ALLISON 3000 RDS AUTOMATIC TRANSMISSION WITH PTO PROVISION
 Gear Ratio: LL N/A
 Gear Ratio: L N/A
 Gear Ratio: 1 3.49
 Gear Ratio: 2 1.86
 Gear Ratio: 3 1.41
 Gear Ratio: 4 1
 Gear Ratio: 5 0.75
 Gear Ratio: 6 0.65
 Gear Ratio: 7 N/A
 Gear Ratio: 8 N/A
 Gear Ratio: 9 N/A
 Gear Ratio: 10 N/A
 Gear Ratio: 11 N/A
 Gear Ratio: 12 N/A
 Gear Ratio: 13 N/A
 Gear Ratio: 14 N/A
 Gear Ratio: 15 N/A
 Gear Ratio: 16 N/A
 Gear Ratio: 17 N/A
 Gear Ratio: 18 N/A
 Low Gear Ratio N/A
 High Gear Ratio N/A
 Low Gear Ratio N/A
 High Gear Ratio N/A
 Rear Axle (420) MT-40-14X 40,000# R-SERIES TANDEM REAR AXLE
 Number of Speeds 1
 Rear Axle Gear Ratio(s) 5.29 REAR AXLE RATIO
 Rear Tires (094) MICHELIN XDE M/S 11R22.5 16 PLY RADIAL REAR TIRES
 Revolutions per Mile 496

TABLE SUMMARY - SHIFT CHART

Transmission Gear	Transmission Gear Ratio	Rear Axle Ratio	Overall Gear Ratio	Percent Split	RPM After Shift	MPH at Peak Torque RPM	MPH at Governed
1	3.49	5.29	18.46	N/A	800	9.2	13.8
2	1.86	5.29	9.84	87.6	1119	17.2	25.8
3	1.41	5.29	7.46	31.9	1592	22.7	34.1
4	1.00	5.29	5.29	41.0	1489	32.0	48.0
5	0.75	5.29	3.97	33.3	1575	42.7	64.0
6	0.65	5.29	3.44	15.4	1820	49.3	73.9

Performance calculations are estimates only. If performance calculations are critical, please contact Customer Application Engineering.



Prepared for:
ALAN CUMMINGS
STATE OF WEST VIRGINIA
2019 WASHINGTON ST EAST
PO BOX 50130
CHARLESTON, WV 25305
Phone: 304-558-2402

Prepared by:
Bobby Slade
HERITAGE EQUIPMENT, INC.
322 DRY HILL RD.
BECKLEY, WV 25801
Phone: (304) 254-7827



Prepared for:
 ALAN CUMMINGS
 STATE OF WEST VIRGINIA
 2019 WASHINGTON ST EAST
 PO BOX 50130
 CHARLESTON, WV 25305
 Phone: 304-558-2402

Prepared by:
 Bobby Slade
 HERITAGE EQUIPMENT, INC.
 322 DRY HILL RD.
 BECKLEY, WV 25801
 Phone: (304) 254-7827

D I M E N S I O N S

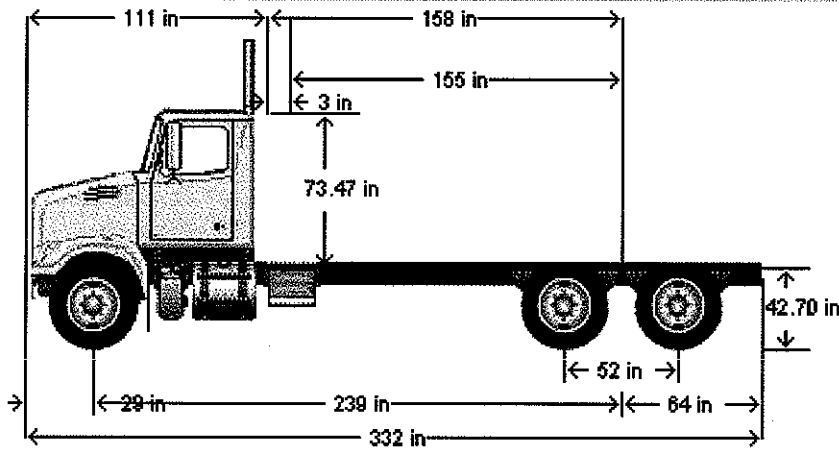

VEHICLE SPECIFICATIONS SUMMARY - DIMENSIONS

Model.....	4700SF
Wheelbase (545)	6075MM (239 INCH) WHEELBASE
Rear Frame Overhang (552)	1625MM (64 INCH) REAR FRAME OVERHANG
Fifth Wheel (578)	NO FIFTH WHEEL
Mounting Location (577).....	NO FIFTH WHEEL LOCATION
Maximum Forward Position (in).....	0
Maximum Rearward Position (in)	0
Amount of Slide Travel (in).....	0
Slide Increment (in).....	0
Desired Slide Position (in).....	0.0
Cab Size (829).....	110 INCH BBC STEEL CONVENTIONAL CAB
Sleeper (682).....	NO SLEEPER BOX/SLEEPER CAB
Exhaust System (016).....	RH OUTBOARD UNDER STEP MOUNTED HORIZONTAL AFTERTREATMENT SYSTEM ASSEMBLY WITH RH B-PILLAR MOUNTED VERTICAL TAILPIPE



Prepared for:
 ALAN CUMMINGS
 STATE OF WEST VIRGINIA
 2019 WASHINGTON ST EAST
 PO BOX 50130
 CHARLESTON, WV 25305
 Phone: 304-558-2402

Prepared by:
 Bobby Slade
 HERITAGE EQUIPMENT, INC.
 322 DRY HILL RD.
 BECKLEY, WV 25801
 Phone: (304) 254-7827

TABLE SUMMARY - DIMENSIONS

Dimensions	Inches
Bumper to Back of Cab (BBC)	110.7
Bumper to Centerline of Front Axle (BA)	29.5
Min. Cab to Body Clearance (CB)	3.0
Back of Cab to Centerline of Rear Axle(s) (CA)	157.8
Effective Back of Cab to Centerline of Rear Axle(s) (Effective CA)	154.8
Back of Cab Protrusions (Exhaust/Intake) (CP)	0.0
Back of Cab Protrusions (Side Extenders/Trim Tab) (CP)	0.0
Back of Cab Clearance (CL)	3.0
Back of Cab to End of Frame	221.8
Cab Height (CH)	73.5
Wheelbase (WB)	239.0
Frame Overhang (OH)	64.0
Overall Length (OAL)	332.5
Rear Axle Spacing	52.0
Unladen Frame Height at Centerline of Rear Axle	42.7

Performance calculations are estimates only. If performance calculations are critical, please contact Customer Application Engineering.

