



SALES PROPOSAL

RECEIVED
2012 SEP 27 AM 10: 01
WV PURCHASING
DIVISION



Sales Proposal

Sold To:
 State of West Virginia - Department HHS
 2019 Washington Street East
 Charleston, WV 25305

Ship To:
 State of West Virginia - Department HHS
 2019 Washington Street East
 Charleston, WV 25305

Contact: Roberta Wagner
Email: roberta.a.wagner@wv.gov
Phone: 304-558-0067
Fax: 304-558-4115

Proposal Date	Expiration	F.O.B.	Ship Via	Terms of Payment	Sales Rep
9/26/12	10/11/12	ORIGIN	BEST WAY	Balance on Receipt	Nick Morgan

Item/Description	Amount
------------------	--------

System

AMSCO 3085 SP "General Surgical Table" RECONDITIONED
 The AmSCO 3085 SP general surgical table provides complete flexibility with its five-way patient positioning through automatic translation of functions for reverse patient positioning, Bieri hydraulics for precise tabletop articulation, T-shaped pedestal design and reverse orientation to provide optimal access to the patient, radiolucent tabletop ensures superior fluoroscopic imaging, locking side-tilt cylinder to prevent unanticipated lateral movement, battery backup override protection during power outages.

\$21,800.00

Training

On-Site System Set up/In-Service Training

Included

Warranty

Warranty - 90 days parts and labor
 *Includes 24/7 Technical Support
 Extended Warranty available at "Point of Sale" only

Included
 Included
 Optional

Comments:

Competitive Flexible Financing options available. (ask for details)
 Extended Service/Warranty options available (ask for details)

This quote is subject to BOX Terms and Conditions which are incorporated by reference and attached hereto.
 Applicable taxes will be added to your final invoice.

accepted by: _____	Total:	\$21,800.00
--------------------	---------------	--------------------

Blue Ox Terms & Conditions of Sale

All sales are made subject to the following terms and conditions. Blue Ox Medical Technologies, LLC's (BLUE OX) acceptance of any purchase order is expressly made conditional on Customer's assent to these terms and conditions.

- Price:** By signing this Agreement and/or presenting a deposit, Customer accepts the prices and terms of payment stated for the Product or Products that is the subject of this Agreement. All deliveries are F.O.B. BLUE OX's location or the equipment's location, freight prepaid or freight collect to destination. If shipped freight prepaid, the charge for freight will be added to the invoice. All taxes of any kind levied by a Federal, State, Municipal or other governmental authority which BLUE OX is required to collect or pay with respect to the sale or shipment of the equipment sold hereunder shall be the responsibility of Customer. Customer agrees to pay all such taxes and further agrees to reimburse BLUE OX for any such payments made by BLUE OX. If the terms of the sale are other than cash, BLUE OX shall have a security interest in the equipment to secure full payment for the equipment. BLUE OX may, at its option file a UCC financing statement or similar document as necessary to perfect its security interest. The cost of any such filing shall be added to the purchase price. In the event Customer fails to make payment of the purchase price or any portion thereof when due, BLUE OX shall have the right to employ an attorney to collect the balance due and Customer agrees to pay all collection costs incurred by BLUE OX, including its reasonable attorneys' fees. BLUE OX may charge interest on past due amounts at the rate of 1 1/2% per month, but not in excess of the maximum rate permitted by law.
- Exchange/Core Charge Policy (Parts or Peripherals):** Exchanges must be returned to BLUE OX within 7 days of delivery. Exchanges must be original OEM parts of the exact same part number. Exchanges that have been opened, attempted to be repaired, or otherwise altered or tampered with or otherwise did not fail under normal use will not be accepted. BLUE OX reserves the right to charge the listed core charge if the item is not received within the 7 day period. If the exchange is received between 7 and 14 days of delivery, 50% of the Core Charge will be billed as defined below. If the exchange has not been received within 14 days, BLUE OX reserves the right to charge the OEM outright list price plus 10% as an additional billing. The Core Charge for exchanges is defined as an additional billing equal to the OEM list price for that part PLUS 10%. Core Charge Invoices received for non-returned exchange/core charges are NET 5 from Invoice Date.
- Return Policy for Parts & Consumables:** Customer shall inspect all parts, probes and peripherals upon delivery and notify BLUE OX immediately of any defect. Warranty returns will be handled as provided in paragraph 4 below. Non-warranty returns must be received by BLUE OX within 5 days from the shipment date. BLUE OX reserves the right to charge a restocking fee of up to 25% to all returned items. Full systems or other special order items are not returnable unless agreed to in writing by BLUE OX. No credit will be granted for any Products returned without a valid return material authorization number (RMA#) that can be received by contacting returns@blueox1.com. Credits for paid orders can be applied to future orders but all credits expire 90 days after issued.
- Loaner Parts:** If the Customer receives a loaner part from BLUE OX, the Customer has 5 days from the receipt of the repair quote to approve the repair or return the Loaner part. Additionally, the Customer has 3 days from the receipt of the repaired part to return the Loaner part to BLUE OX. Failure to approve the quote or return the Loaner part as stated herein will result in a Loaner Fee additional billing of \$250 per five (5) business days. Failure to return a Loaner part after 15 days will result in an additional billing to include all outstanding Loaner fees plus the outright price of the part that is defined as the OEM list plus 10%. All Loaner fee additional billings are due NET 5 from invoice date.
- Hero Kits:** If the Customer receives a "Hero Kit" from BLUE OX, the Customer has 5 days to return the Hero Kit to BLUE OX from the date of receipt. If a portion of the Hero Kit is used, the Customer will be billed for the parts consumed and there will be no additional charge to return the unused parts. If no parts are used, and there is no subsequent Hero Kit to resolve the same service event, then a restock fee of 25% will be charged on the highest value part in the Hero Kit. All additional Hero Kit Billings will be due NET 5 from invoice date. If a Hero Kit is not returned within 5 days of receipt, the Customer will be charged as follows unless BLUE OX otherwise agrees in writing: If the Hero kit return is received between 5 and 10 days of delivery, 50% of the outright price (as defined below) will be billed. If the Hero Kit has not been returned within 10 days, BLUE OX reserves the right to charge the OEM outright list price plus 10% as an additional billing. The outright price for Hero Kit parts is defined as OEM list price for that part PLUS 10%. Hero Kit Invoices received for non-returned Hero Kits are NET 5 from Invoice Date.
- Limited Warranty:** For a period of 30 days from the date of delivery (unless otherwise specified in the sales order), BLUE OX warrants that all equipment or service will be free from material defects and will perform substantially in accordance with the original equipment manufacturers written technical specifications for that equipment or service. If BLUE OX is notified of any material defects within such 30 day period (unless otherwise specified in the sales order), BLUE OX will have the option of repairing or replacing the equipment or refunding the purchase price. This warranty does not extend to any equipment which has been (a) subject to misuse, neglect, accident, fire, lightning or other casualty, (b) installed, repaired or altered by anyone other than BLUE OX or its authorized representatives, (c) moved from its original location or no longer owned and used by the Customer named herein, and (d) is not transferable to any other party. THIS WARRANTY IS IN LIEU OF AND EXCLUDES ALL OTHER EXPRESS OR IMPLIED WARRANTIES, Macintosh HD:Users:rdienst:Dropbox:0 - Blue Ox:Legal Docs:2011 Blue Ox T&Cs.docx

INCLUDING ANY WARRANTY OF MERCHANTABILITY OR FITNESS FOR A PARTICULAR PURPOSE. CUSTOMER'S EXCLUSIVE REMEDY AGAINST BLUE OX AND BLUE OX'S SOLE OBLIGATION, FOR ANY AND ALL CLAIMS, WHETHER FOR BREACH OF CONTRACT, WARRANTY, TORT (INCLUDING NEGLIGENCE), OR OTHERWISE, SHALL BE LIMITED TO BLUE OX'S REPAIRING OR REPLACING THE DEFECTIVE EQUIPMENT, OR AT BLUE OX'S OPTION, REFUNDING THE PURCHASE PRICE. IN NO EVENT SHALL BLUE OX HAVE ANY LIABILITY FOR DAMAGES IN AN AMOUNT EXCEEDING THE PURCHASE PRICE OF THE EQUIPMENT SOLD HEREUNDER, NOR SHALL BLUE OX HAVE ANY LIABILITY FOR INCIDENTAL OR CONSEQUENTIAL DAMAGES.

- Shipping and Delivery:** Standard delivery time for any Systems is 4 to 12 weeks after receipt of signed order, deposit, and all necessary paperwork depending on the product and modality. Standard delivery times for any part order is 3 business days after receipt of signed order, PO and all necessary paperwork. Delivery dates are approximate. BLUE OX shall not be responsible for delays in delivery or performance due to causes beyond its reasonable control, including, but not limited to, acts of God, acts of Customer, strikes or other labor disturbances, inability to obtain fuel, materials, or parts, delays in transportation, repairs to the equipment, fires or accidents. Partial shipments are allowed if any items on an order are backordered. BLUE OX reserves the right to invoice for the items that are shipped and will backorder items that did not ship. Partial payments for invoiced items are not allowed unless approved by both parties in writing before the equipment is shipped to Customer. All Invoices, including those for partial shipments, are due from the invoice date and Payment shall not be withheld for shipped items notwithstanding that other items are backordered.
- Risk of Loss:** Risk of loss or damage to the equipment in transit shall be borne by BLUE OX and claims shall be made directly with the carrier unless the Customer has made its own shipping arrangements.
- Assignment:** This Agreement may not be assigned, in whole or in part by Customer, without the written consent of BLUE OX.
- Indemnification:** Customer shall indemnify and hold BLUE OX harmless from and against any and all costs, fees, expenses, liabilities and claims (including, without limitation BLUE OX's reasonable attorneys' fees and costs) incurred by or asserted against BLUE OX arising out of or related to this Agreement not caused by the negligence of BLUE OX. BLUE OX shall indemnify and hold Customer harmless from and against any and all costs, fees, expenses, liabilities and claims (including, without limitation, Customer's reasonable attorneys' fees and costs) incurred by or asserted against Customer arising out of or related to this agreement not caused by the negligence of the customer.
- Governing Law:** This Agreement and its enforcement shall be governed by, and construed in accordance with, the laws of the State of North Carolina. Customer, acting for itself and its successors and assigns, hereby expressly and irrevocably consents to the exclusive jurisdiction of the state and federal courts of Charlotte or Mecklenburg County, North Carolina for any litigation or arbitration award which may arise out of or be related to this Agreement. Customer waives any objection based on forum non conveniens or any objection to venue of any such action.
- Entire Agreement:** This Agreement (which consists of this Selling Agreement and any other necessary documents) constitutes the entire understanding between the parties, and supersedes all proposals, oral or written, and all other communications between the parties relating to the subject matter of this Agreement. Any modification to this Agreement must be in writing and signed by all parties to this Agreement. Any provision(s) of Customer's own purchase order form that differs in any manner from, or contains terms in addition to those set forth in this Agreement shall be of no force or effect. By signing this Agreement, Customer expressly agrees to be bound by the terms and conditions hereof, notwithstanding any terms and conditions in Customer's own documents to the contrary. BLUE OX's acceptance of Customer's purchase order is expressly made conditional on Customer's assent to the terms of this Agreement. Any terms that differ in any manner from or are in addition to the provisions of this Agreement shall be of no force or effect. Any clerical errors (for example, mathematical mistakes) are subject to correction to reflect the intent of the parties.
- Severability:** If any provision(s) of this Agreement shall be determined by a court of competent jurisdiction to be invalid, illegal or otherwise unenforceable, the validity, legality, and enforceability of the remaining provisions shall not in any way be affected or impaired thereby.

The terms and conditions of this Agreement shall apply to all equipment ordered by Customer from BLUE OX from and after the date hereof, except as otherwise expressly specified in an order signed by BLUE OX.

Company Name: _____

Name / Title: _____

Printed Name / Title: _____

Authorized Signature: _____ Date: _____



SALES PROPOSAL



Sales Proposal

Sold To:
 State of West Virginia - Department HHS
 2019 Washington Street East
 Charleston, WV 25305

Ship To:
 State of West Virginia - Department HHS
 2019 Washington Street East
 Charleston, WV 25305

Contact: Roberta Wagner
Email: roberta.a.wagner@wv.gov
Phone: 304-558-0067
Fax: 304-558-4115

Proposal Date	Expiration	F.O.B.	Ship Via	Terms of Payment	Sales Rep
9/26/12	10/11/12	ORIGIN	BEST WAY	Balance on Receipt	Nick Morgan
Item/Description					Amount

System

BIODEX 058-800 "Surgical Urology Table" NEW
 - Low Attenuation Carbon Fiber tabletop with innovative design
 - Low profile base for C-Arm clearance
 - 500lb patient capacity
 - High speed actuator for quick vertical movement
 - Accessory Rails
 - Large 54" x 17.5" radiolucent area
 - Fowler back (0° to 80°)
 - Five-axis motorized tabletop positioning
 - Four convenient positioning controllers (main panel control, joystick control with variable speed, hand-held controller and foot controller)
 - Smooth starts and stops programmed into all motorized movements
 - Low profile base for C-Arm clearance
 - Both AC and battery power are standard
 - Includes 1 Year Biodex Warranty
 - (See attached specifications for more details)

\$31,700.00

Options / Peripherals

- 058-848 Catheter Tray Extension (removable) \$400.
- 056-850 IV Pole, Rail Mounted \$390.
- 056-865 Arm Board, Carbon Fiber, one arm \$600.
- 056-866 Arm Board, Carbon Fiber, two arms \$1,150.
- 058-864 Arm Board, Surgical, Carbon Fiber. \$2,495.
- 058-856 Radiation Shield, Head/Cervical. \$1,595.
- 058-857 Radiation Shield, Thoracic/AB. \$1,695.
- 058-849 Clamp, Accessory, C-Arm Table. \$695.

Warranty

Warranty, 1 Year (Parts and Labor) Included
 Extended Warranty available at "Point of Sale Only" (\$750./year)

Comments:

This quote is subject to BOX Terms and Conditions which are incorporated by reference and attached hereto.
 Quoted price does not include Shipping and Handling (\$750.) Applicable taxes will be added to your final invoice.

accepted by: _____	Total:	\$ 31,700.00
--------------------	---------------	---------------------

Blue Ox Terms & Conditions of Sale

All sales are made subject to the following terms and conditions. Blue Ox Medical Technologies, LLC's (BLUE OX) acceptance of any purchase order is expressly made conditional on Customer's assent to these terms and conditions.

1. **Price:** By signing this Agreement and/or presenting a deposit, Customer accepts the prices and terms of payment stated for the Product or Products that is the subject of this Agreement. All deliveries are F.O.B. BLUE OX's location or the equipment's location, freight prepaid or freight collect to destination. If shipped freight prepaid, the charge for freight will be added to the invoice. All taxes of any kind levied by a Federal, State, Municipal or other governmental authority which BLUE OX is required to collect or pay with respect to the sale or shipment of the equipment sold hereunder shall be the responsibility of Customer. Customer agrees to pay all such taxes and further agrees to reimburse BLUE OX for any such payments made by BLUE OX. If the terms of the sale are other than cash, BLUE OX shall have a security interest in the equipment to secure full payment for the equipment. BLUE OX may, at its option file a UCC financing statement or similar document as necessary to perfect its security interest. The cost of any such filing shall be added to the purchase price. In the event Customer fails to make payment of the purchase price or any portion thereof when due, BLUE OX shall have the right to employ an attorney to collect the balance due and Customer agrees to pay all collection costs incurred by BLUE OX, including its reasonable attorneys' fees. BLUE OX may charge interest on past due amounts at the rate of 1 1/2% per month, but not in excess of the maximum rate permitted by law.
 2. **Exchange/Core Charge Policy (Parts or Peripherals):** Exchanges must be returned to BLUE OX within 7 days of delivery. Exchanges must be original OEM parts of the exact same part number. Exchanges that have been opened, attempted to be repaired, or otherwise altered or tampered with or otherwise did not fail under normal use will not be accepted. BLUE OX reserves the right to charge the listed core charge if the item is not received within the 7 day period. If the exchange is received between 7 and 14 days of delivery, 50% of the Core Charge will be billed as defined below. If the exchange has not been received within 14 days, BLUE OX reserves the right to charge the OEM outright list price plus 10% as an additional billing. The Core Charge for exchanges is defined as an additional billing equal to the OEM list price for that part PLUS 10%. Core Charge Invoices received for non-returned exchange/core charges are NET 5 from Invoice Date.
 3. **Return Policy for Parts & Consumables:** Customer shall inspect all parts, probes and peripherals upon delivery and notify BLUE OX immediately of any defect. Warranty returns will be handled as provided in paragraph 4 below. Non-warranty returns must be received by BLUE OX within 5 days from the shipment date. BLUE OX reserves the right to charge a restocking fee of up to 25% to all returned items. Full systems or other special order items are not returnable unless agreed to in writing by BLUE OX. No credit will be granted for any Products returned without a valid return material authorization number (RMA#) that can be received by contacting returns@blueox1.com. Credits for paid orders can be applied to future orders but all credits expire 90 days after issued.
 4. **Loaner Parts:** If the Customer receives a Loaner part from BLUE OX, the Customer has 5 days from the receipt of the repair quote to approve the repair or return the Loaner part. Additionally, the Customer has 3 days from the receipt of the repaired part to return the Loaner part to BLUE OX. Failure to approve the quote or return the Loaner part as stated herein will result in a Loaner Fee additional billing of \$250 per five (5) business days. Failure to return a Loaner part after 15 days will result in an additional billing to include all outstanding Loaner fees plus the outright price of the part that is defined as the OEM list plus 10%. All Loaner fee additional billings are due NET 5 from invoice date.
 5. **Hero Kits:** If the Customer receives a "Hero Kit" from BLUE OX, the Customer has 5 days to return the Hero Kit to BLUE OX from the date of receipt. If a portion of the Hero Kit is used, the Customer will be billed for the parts consumed and there will be no additional charge to return the unused parts. If no parts are used, and there is no subsequent Hero Kit to resolve the same service event, then a restock fee of 25% will be charged on the highest value part in the Hero Kit. All additional Hero Kit Billings will be due NET 5 from invoice date. If a Hero Kit is not returned within 5 days of receipt, the Customer will be charged as follows unless BLUE OX otherwise agrees in writing: If the Hero kit return is received between 5 and 10 days of delivery, 50% of the outright price (as defined below) will be billed. If the Hero Kit has not been returned within 10 days, BLUE OX reserves the right to charge the OEM outright list price plus 10% as an additional billing. The outright price for Hero Kit parts is defined as OEM list price for that part PLUS 10%. Hero Kit Invoices received for non-returned Hero Kits are NET 5 from Invoice Date.
 6. **Limited Warranty:** For a period of 30 days from the date of delivery (unless otherwise specified in the sales order), BLUE OX warrants that all equipment or service will be free from material defects and will perform substantially in accordance with the original equipment manufacturers written technical specifications for that equipment or service. If BLUE OX is notified of any material defects within such 30 day period (unless otherwise specified in the sales order), BLUE OX will have the option of repairing or replacing the equipment or refunding the purchase price. This warranty does not extend to any equipment which has been (a) subject to misuse, neglect, accident, fire, lightning or other casualty, (b) installed, repaired or altered by anyone other than BLUE OX or its authorized representatives, (c) moved from its original location or no longer owned and used by the Customer named herein, and (d) is not transferable to any other party. THIS WARRANTY IS IN LIEU OF AND EXCLUDES ALL OTHER EXPRESS OR IMPLIED WARRANTIES,
- INCLUDING ANY WARRANTY OF MERCHANTABILITY OR FITNESS FOR A PARTICULAR PURPOSE. CUSTOMER'S EXCLUSIVE REMEDY AGAINST BLUE OX AND BLUE OX'S SOLE OBLIGATION, FOR ANY AND ALL CLAIMS, WHETHER FOR BREACH OF CONTRACT, WARRANTY, TORT (INCLUDING NEGLIGENCE), OR OTHERWISE, SHALL BE LIMITED TO BLUE OX'S REPAIRING OR REPLACING THE DEFECTIVE EQUIPMENT, OR AT BLUE OX'S OPTION, REFUNDING THE PURCHASE PRICE. IN NO EVENT SHALL BLUE OX HAVE ANY LIABILITY FOR DAMAGES IN AN AMOUNT EXCEEDING THE PURCHASE PRICE OF THE EQUIPMENT SOLD HEREUNDER, NOR SHALL BLUE OX HAVE ANY LIABILITY FOR INCIDENTAL OR CONSEQUENTIAL DAMAGES.
7. **Shipping and Delivery:** Standard delivery time for any Systems is 4 to 12 weeks after receipt of signed order, deposit, and all necessary paperwork depending on the product and modality. Standard delivery times for any part order is 3 business days after receipt of signed order, PO and all necessary paperwork. Delivery dates are approximate. BLUE OX shall not be responsible for delays in delivery or performance due to causes beyond its reasonable control, including, but not limited to, acts of God, acts of Customer, strikes or other labor disturbances, inability to obtain fuel, materials, or parts, delays in transportation, repairs to the equipment, fires or accidents. Partial shipments are allowed if any items on an order are backordered. BLUE OX reserves the right to invoice for the items that are shipped and will backorder items that did not ship. Partial payments for invoiced items are not allowed unless approved by both parties in writing before the equipment is shipped to Customer. All Invoices, including those for partial shipments, are due from the Invoice date and Payment shall not be withheld for shipped items notwithstanding that other items are backordered.
 8. **Risk of Loss:** Risk of loss or damage to the equipment in transit shall be borne by BLUE OX and claims shall be made directly with the carrier unless the Customer has made its own shipping arrangements.
 9. **Assignment:** This Agreement may not be assigned, in whole or in part by Customer, without the written consent of BLUE OX.
 10. **Indemnification:** Customer shall indemnify and hold BLUE OX harmless from and against any and all costs, fees, expenses, liabilities and claims (including, without limitation BLUE OX's reasonable attorneys' fees and costs) incurred by or asserted against BLUE OX arising out of or related to this Agreement not caused by the negligence of BLUE OX. BLUE OX shall indemnify and hold Customer harmless from and against any and all costs, fees, expenses, liabilities and claims (including, without limitation, Customer's reasonable attorneys' fees and costs) incurred by or asserted against Customer arising out of or related to this agreement not caused by the negligence of the customer.
 11. **Governing Law:** This Agreement and its enforcement shall be governed by, and construed in accordance with, the laws of the State of North Carolina. Customer, acting for itself and its successors and assigns, hereby expressly and irrevocably consents to the exclusive jurisdiction of the state and federal courts of Charlotte or Mecklenburg County, North Carolina for any litigation or arbitration award which may arise out of or be related to this Agreement. Customer waives any objection based on forum non conveniens or any objection to venue of any such action.
 12. **Entire Agreement:** This Agreement (which consists of this Selling Agreement and any other necessary documents) constitutes the entire understanding between the parties, and supersedes all proposals, oral or written, and all other communications between the parties relating to the subject matter of this Agreement. Any modification to this Agreement must be in writing and signed by all parties to this Agreement. Any provision(s) of Customer's own purchase order form that differs in any manner from, or contains terms in addition to those set forth in this Agreement shall be of no force or effect. By signing this Agreement, Customer expressly agrees to be bound by the terms and conditions hereof, notwithstanding any terms and conditions in Customer's own documents to the contrary. BLUE OX's acceptance of Customer's purchase order is expressly made conditional on Customer's assent to the terms of this Agreement. Any terms that differ in any manner from or are in addition to the provisions of this Agreement shall be of no force or effect. Any clerical errors (for example, mathematical mistakes) are subject to correction to reflect the intent of the parties.
 13. **Severability:** If any provision(s) of this Agreement shall be determined by a court of competent jurisdiction to be invalid, illegal or otherwise unenforceable, the validity, legality, and enforceability of the remaining provisions shall not in any way be affected or impaired thereby.
- The terms and conditions of this Agreement shall apply to all equipment ordered by Customer from BLUE OX from and after the date hereof, except as otherwise expressly specified in an order signed by BLUE OX.
- Company Name: _____
- Name / Title: _____
- Printed Name / Title: _____
- Authorized Signature: _____ Date: _____

UROLOGY C-ARM TABLE & BRACHYTHERAPY C-ARM TABLE

OPERATION MANUAL

058-800
058-805
058-810
058-815

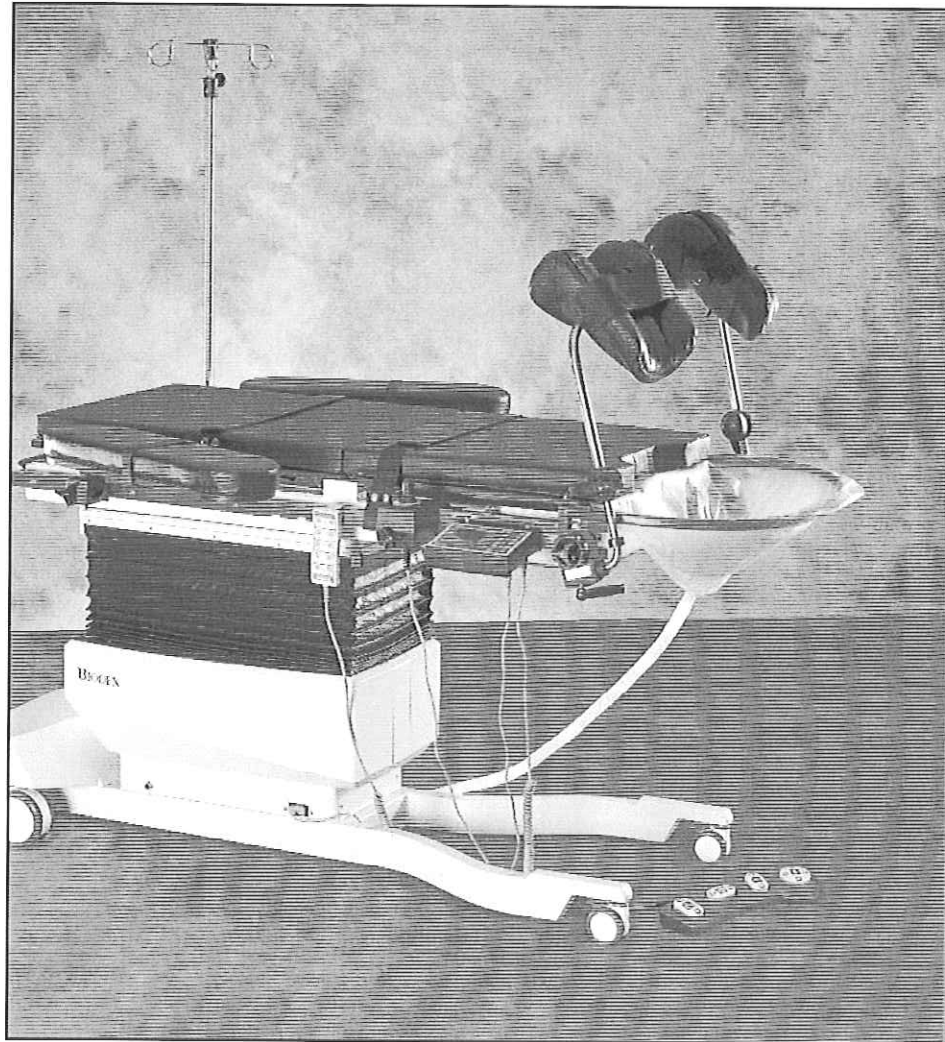

BIODEX

Biomedex Medical Systems, Inc.

20 Ramsay Road, Shirley, New York, 11967-4704, Tel: 800-224-6339 (*but 631-924-9000*), Fax: 631-924-9241, Email: info@biomedex.com, www.biomedex.com

UROLOGY AND BRACHYTHERAPY C-ARM TABLE

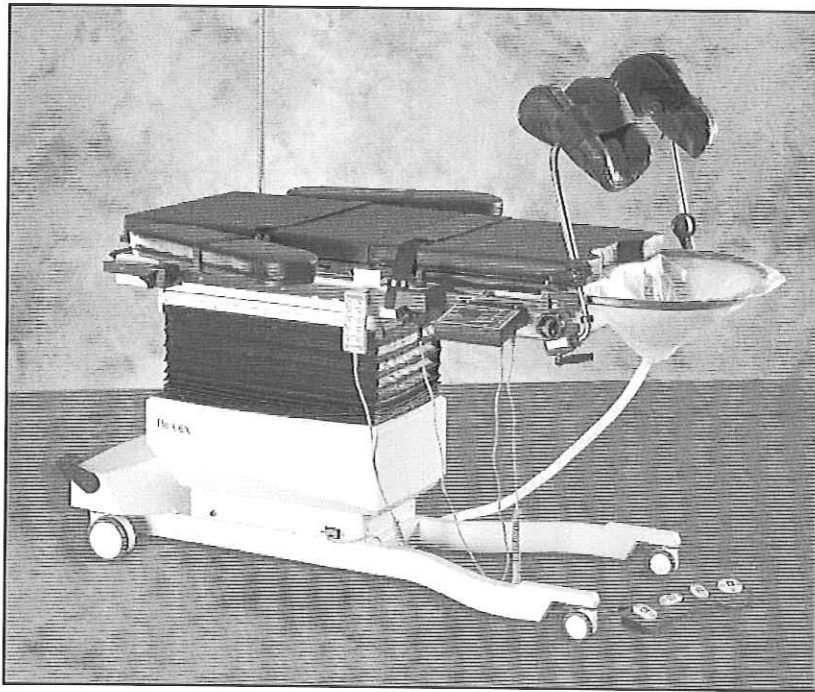





This manual covers installation and operation procedures for the following Urology and Brachytherapy C-Arm Table products:

- #058-800 Urology C-Arm Table, 115 VAC
- #058-805 Urology C-Arm Table, 230 VAC
- #058-810 Brachytherapy C-Arm Table, 115 VAC
- #058-815 Brachytherapy C-Arm Table, 230 VAC

NOTE: All or some of the following symbols, cautions, warnings and notes may apply to your Biomedex product and correspond to this operation manual.

Symbol Meaning

-  Attention, consult accompanying documents.
-  Symbol signification: Attention, se référer à la notice.
-  Warning: Injuries to health may result from incorrect or excessive training.
-  Attention: Incorrect ou extrême entraînement peut aboutir des lésions au santé.

NOTE: Circuit diagrams for this product are available upon request.





UROLOGY AND BRACHYTHERAPY C-ARM TABLES

INTRODUCTION

The Urology and Brachytherapy C-Arm Tables feature motorized actuation of height, X-Y tabletop, lateral roll and Trendelenburg motions, and is supported by a full line of optional accessories.

Both AC and battery power are standard. When operating on battery, there are no power cords to catch on feet or block table wheels. Battery charging can be accomplished during off-hours by plugging in the AC power cord. An additional, optional battery and charging unit can provide continuous cordless operation.

 **IMPORTANT NOTE:** Remove battery if storing table for prolonged time.

 **IMPORTANT NOTE:** Lever la batterie si le table se garder en reserve por temps prolongement.

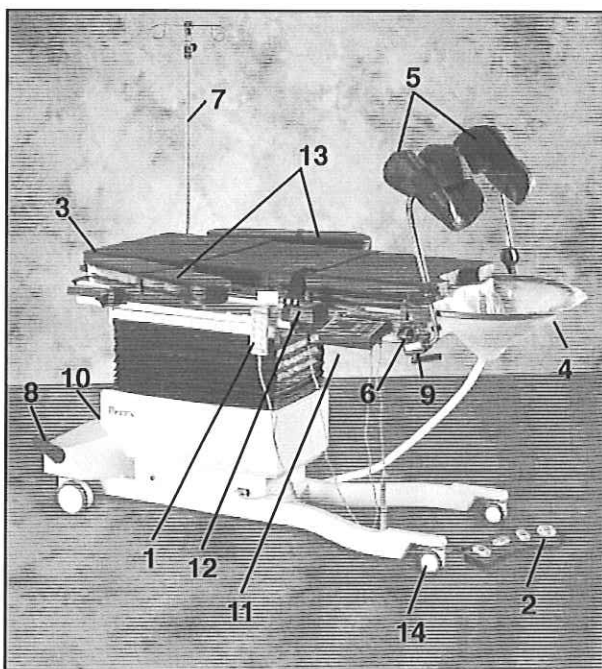

Figure 1. Parts and adjustment mechanisms.

1. Hand-Held Controller
2. Foot Controller
3. Fowler Back
4. Radiolucent Drain Bag Holder and Disposable Bag
5. Left and Right Knee Crutches
6. X-Ray Grid and Film Cassette Tray
7. Rail-Mounted I.V. Pole
8. Head End Locking Brakes and Swivel Casters
9. Vertical Doors
(for adding transfer or radiolucent extension)
10. Battery Pack
11. Main Control Panel
12. Joystick Controller
13. Arm Boards
14. Foot End Individual Locking Casters

NOTE: The Brachytherapy C-Arm Table is the same as the Urology C-Arm Table except it does not have the Drain Pan, Radiolucent Drain Bag Holder and Disposable Bags.

OPERATING INSTRUCTIONS

NOTE: This table can be operated with the power cord connected to an outlet or by using the battery. The battery recharges automatically while the table is plugged into an outlet even if the table is being used.

NOTA: Cette table fonctionne avec le cordon d'alimentation branché sur une prise ou à l'aide de la batterie. La batterie se recharge automatiquement lorsque le cordon est branché sur une prise, même si la table est en cours d'utilisation.

 **CAUTION:** Hospital grade plug to be plugged into a hospital grade receptacle only to achieve grounding reliability.

 **ATTENTION:** La fiche de qualité h pital ne doit  tre branch e que sur une prise de courant de qualit  h pital, pour une mise   la terre fiable.

 **CAUTION:** Before transferring a patient onto or off the table, ensure all four caster brakes are locked. Secure the restraining straps immediately after positioning the patient on the table.

 **ATTENTION:** Avant le transfert du patient sur la table ou hors de la table, s'assurer que les quatre freins des roulettes sont bloqu s. Fixer les lani res d'immobilisation d s qu'on a positionn  le patient sur la table.

 **CAUTION:** The restraining straps are not intended to restrain an uncontrolled patient.

 **ATTENTION:** Les lani res d'immobilisation n'ont pas pour objet l'immobilisation d'un patient hors de contr le.

The Locking Brakes and Swivel Casters

(See Figure 2.)

The locking brakes and swivel casters allow this table to glide effortlessly on hard surfaces and across firm rugs.

1. To release the brakes, use your toe to lift up on the caster locking lever (located at the head end of the table).
2. To lock the brakes and roll the table, step down on the caster brake lever.
3. The Foot End Casters are locked and released individually. Press down on the caster brake lever to lock, pull up on the caster break to release.

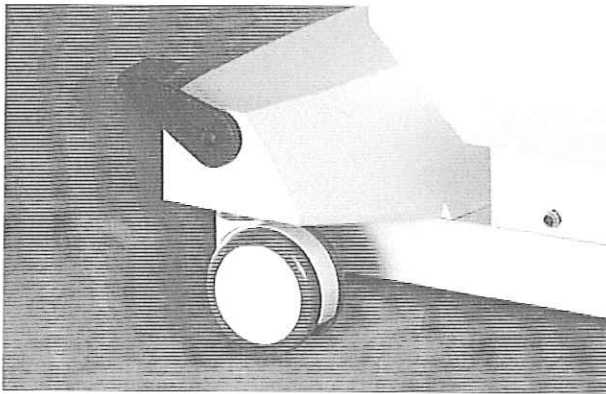

Figure 2. Locking brakes and swivel casters.

The Fowler Back

The Fowler Back, manually adjustable to an 80-degree angle (20°, 30°, 40°, 50°, 60°, 70°, 80°) incorporates a touch-handle lock/unlock mechanism for effortless patient positioning.



CAUTION: You must support the Fowler Back as it is being raised or lowered. The back must lock into one of the eight positions provided.



ATTENTION: On doit soutenir le dossier Fowler pendant qu'on l'élève ou qu'on l'abaisse. Le dossier doit s'enclencher dans l'une des huit positions de verrouillage.

1. To raise the Fowler Back, press the back lock release button on the underside of the Fowler Back handle grasp. Keeping the release button depressed, lift up on the Fowler Back until it attains the desired position. The Fowler Back must be set in one of the eight positions provided.
2. To lower the Fowler Back, depress and hold the Fowler Back button on the underside of the Fowler Back grip and position the top as desired.

Using the Main Control Panel

The LCD Screen of the Main Control Panel displays actual tabletop position (all axes) in real time, and provides menus and prompts for positioning the table and saving up to ten table position settings which can be recalled.

The Main Control Panel can operate off battery or AC power. When the table is turned ON, the display shows the current table position.

The table motion buttons (tabletop X,Y, Trendelenburg, reverse Trendelenburg and lateral roll) are located on the right side of the Main Control Panel and correspond to the illustrations on the display panel. To activate any table motion button, press and hold the Activate button on the bottom left side of the control panel. While holding the Activate button down, press any of the table motion buttons to move the table to the desired position.

At the bottom right of the display, a Level button can be pressed (while holding down the Activate button) to bring the tabletop level at any time. The Home button, located next to the Level button, is used to bring the table to its lowest, level position.

Up to ten table set positions can be stored from the Current Table Position screen using the Main Control Panel. Buttons to perform the save procedure are located immediately to the right of the screen. To save any position in which you place the table, press the Save (top) button. The system will save the appropriate information and assign a numeric value from one to ten for that position. The position values will be displayed on the screen.

If all ten position set values are stored, the display will ask if you would like to delete a position. If so, allow the screen to return to the Current Table Position screen, then press the button opposite the "Display Saved Table Positions" prompt. You can now use the top button to scroll through the position set values until the one you wish to delete is displayed. Press the button opposite the prompt "Delete Saved Position Set." The system will request confirmation to delete. Press the button opposite "Yes" to confirm.

At this point, you can follow the prompts to delete another table position set, choose to move the table to the currently displayed position, or select another position.

Using the Hand-Held Controller

The Hand-Held Controller may be used to adjust table height, Trendelenburg/Reverse Trendelenburg, lateral roll and X-Y positioning. When not in use, the Hand-Held Controller can be hooked onto the metal loop on the restraining strap, or on the the accessory rail.



CAUTION: Before moving the tabletop, be sure that all I.V. lines, attachments and restraining straps, etc., are out of the way. Ensure the patient is fully secured to the tabletop by the restraining straps.



ATTENTION: Avant tout déplacement du dossier, veiller à en dégager les lignes de goutte-à-goutte intravéneux, les accessoires, les lanières d'immobilisation, etc. S'assurer que le patient est solidement fixé au dossier à l'aide des lanières d'immobilisation.

To adjust the table position, press and hold the appropriate switch on the Hand-Held Controller. The tabletop will move or rotate in the direction indicated by the switch. Release the switch when the tabletop achieves the desired position.

Using the Joystick Controller

The Joystick Controller for motorized X-Y positioning allows intuitive positioning with proportional speed control. An adjustable icon indicator, on the top base of the joystick, can be rotated so that the joystick X-Y positioning correlates directionally to actual tabletop motion. If you move the joystick to the opposite accessory rail, be sure to rotate the icons to match.

To prevent undesired motion by accidental contact with the joystick, a thumb button on the top of the joystick must be pressed for activation.

Using the Foot-Controller

(See Figure 3.)

The Foot-Controller activates all motions. The four separate rocker style pedals control two movements each. From left to right on the Foot-Control, press and hold down the appropriate rocker switch to adjust Trendelenburg/Reverse Trendelenburg positioning, lateral roll, tabletop height and X-Y motion. Releasing the rocker switch at any time immediately stops the motion.

NOTE: When the table is used in a wet environment, it is recommended that the Foot Controller be covered with a plastic bag and sealed as watertight as possible.

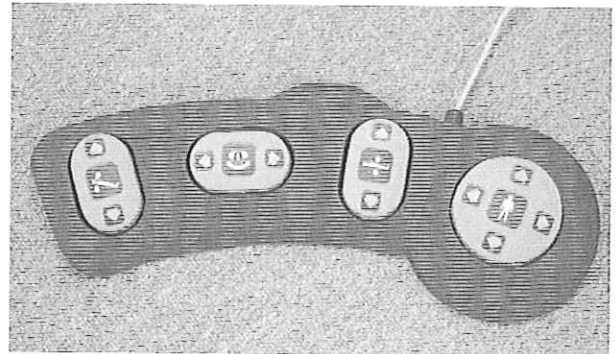

Figure 3. The Foot-Controller can be used to adjust Trendelenburg/Reverse Trendelenburg positioning, lateral roll, tabletop height and X-Y motion.

The Transfer Extension and the Radiolucent Extension (See Figure 4.)

The transfer extension is used to extend the table when putting a patient on or taking a patient off the tabletop. It is not used for imaging. The radiolucent extension, significantly longer than the transfer extension, has a 31" radiolucent C-Arm area with no metal cross members. Both extensions are installed using the same procedure. Once the Radiolucent Extension is in use, the patient load rating is limited to 400 lb (181.4 kg).

To install the extension:

1. Open the vertical doors at the foot end of the table (the doors pivot toward the outside of the table).
2. Pick up the extension from the end and slide the silver, tapered ends into the openings created by opening the vertical doors.
3. Slide the extension fully into the table until you feel the extension lock into place.

To remove the extension from the table:

NOTE: The x-ray grid, film tray and drain pan can remain in place if using the Transfer Extension but must be removed if the Radiolucent Extension is used.

1. Stand at the foot end of the table and press the extension release levers located under the middle of each leg extension rail. You can now slide the extension out from the table.
2. Close the vertical doors.

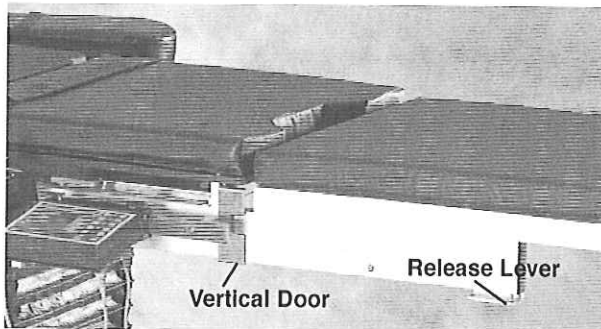

Figure 4. Insert either table extension into the extension receiving tubes. To remove the extension from the table, press the extension release levers and slide the extension out of the table.

Knee Crutch Installation (See to Figure 5.)

The optional Knee Crutch set includes a left and right rail clamp and two offset ratchet arms. Install the rail clamps onto the accessory rails and then the offset ratchet arms with knee crutches into the rail clamps. Note that the offset ratchet arms should be inserted into the knee clamps from the foot end of the table. The wide end of the knee crutches face toward the head end of the table.

To adjust positioning of the offset arms, loosen locking lever on the crutch clamps, move the arms to the desired position and re-tighten the lever.

To adjust positioning of the crutch pads, loosen the crutch pad locking levers and tilt the pads as required.



Figure 5. Knee crutches properly installed.

Arm Boards

Standard or Dura Board Arm Boards are optional. Install the rail clamps onto the accessory rails and then insert the arm board posts into the clamps and tighten to secure. To move the armboards in a horizontal plane, loosen the locking knob on the block, move the armboard to the desired position and re-tighten the knob.

I.V. Pole

The optional adjustable height I.V. pole should be installed onto the accessory rail. Loosen the I.V. pole locking knob at the base of the slide block and slide the block and pole onto the accessory rail until it is in the desired position. Tighten the locking knob to secure the pole.

To adjust the height of the I.V. pole, loosen the height adjustment locking knob and raise or lower the top section of the pole to the appropriate height. Tighten the locking knob to secure.

The Drain Bag Holder (See Figure 6.)

An optional, flexible drain bag holder is available for this table. To install, loosen the clamps on the drain bag holder bar provided. Slide the clamps over the accessory rails at the foot end of the table and tighten the clamps when the bar is appropriately positioned. Lift up the table cushion at the foot end of the table and slide the front (square) section of the flexible disposable bag under the cushion. You can now work the remainder of the drain bag into position around the bar. The top of the bag folds over the bar.

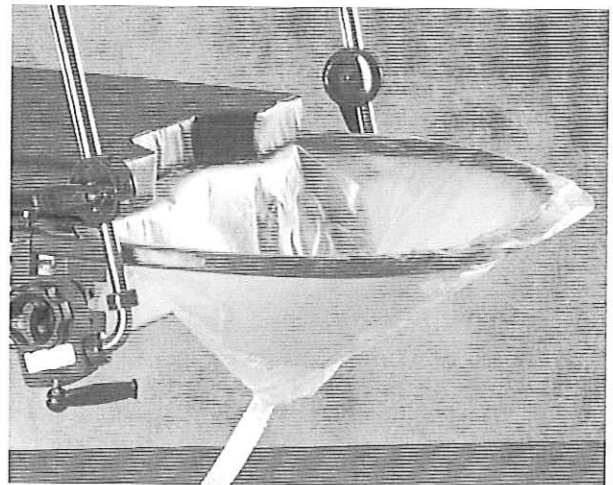

Figure 6. The drain bag holder and flexible, disposable drain bag properly installed.

The Drain Pan

(See Figure 7.)

The stainless steel drain pan and wire mesh screen are optional. To insert the drain pan, open the vertical doors at the foot end of the table (the doors pivot toward the outside of the table.) Pull out on the drain pan support bars until they are fully extended. You can now place the pan between the bars so that it is supported by the bars. Slide the pan along the bars until you feel it drop into the notches. If desired, the pan can be stored in the table by simply pushing in on the drain pan support bars.

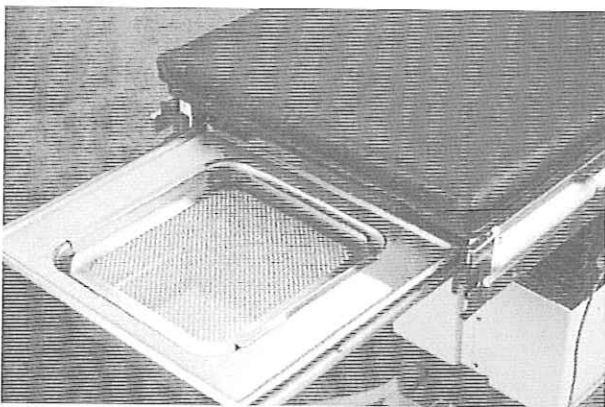

Figure 7. The drain pan properly installed.

X-Ray Grid

The optional, removable x-ray grid is 103 line, 8:1 ratio, 36" to 44" focal range grid. There is a set of tracks about 1" above the film cassette tray tracks which holds the grid in the body of the table. The grid can be inserted or removed from either side of the table.

To remove the x-ray grid, lift the grid up approximately 1/4" and then slide it out that side of the table. To insert the grid, place the grid on the track with the center line of the grid running "head to toe" and the center line facing upward. Insert the grid into the body of the table until it "drops in" past the stop notch mechanism. The x-ray grid should remain in the table at all times except when the table is being used for fluoroscopic purposes.

Radiographic Film Cassette Tray

(See Figure 8.)

The optional Radiographic Film Cassette Tray can be inserted or removed from either side of the table. This tray will hold a 14" x 17" film lengthwise or crosswise between the four pegs in the tray. Also provided with the tray is a small film cassette mask. This film cassette mask is designed to hold a 10" x 12" film down at that perineal end of the table or for pediatric retrograde pyelogram studies.

To insert the film into the tray, grasp the tray handle and lift upward approximately 1/4" and then extend the film tray out to the desired side of the table. Insert the film cassette into the tray, then push the film tray back into the body of the table until you feel it "drop in" past the stop notch mechanism.

To remove the cassette, grasp the tray handle and lift it up 1/4" before sliding it toward the side of the table. It is not necessary to remove the tray to remove the cassette. There are holes under the cassette tray. Push up under the tray to raise the cassette enough to grab it and remove it from the table.

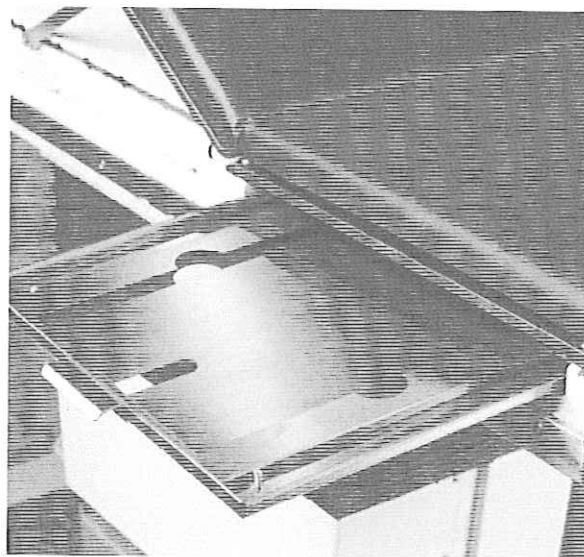

Figure 8. The Radiographic Film Cassette Tray.

Disposable Skirt

(See Figure 9.)

The Biodex Urology Table includes a supply of disposable plastic sanitary skirts to protect the table bellows from patient blood, liquids, etc. The table is encircled by a magnetic-backed rubber strip, located immediately above the bellows. Secure the skirt to the bellows as described.

1. Lift the lower section of the strip on each side of the table.
2. Slide the plastic skirt underneath the strip at the foot end of the table, then lower the strip to hold the skirt in place.
3. Work around the table, tucking the top edge of the plastic skirt under each strip and lowering the strip to secure the plastic until the bellows are completely unwrapped. Be sure to overlap the skirt across the entire length of the table's foot end.
4. Remove and replace the plastic skirt for each new patient.

NOTE: Additional Bellows Skirts (part #056-802) can be ordered from Biodex Medical Systems, Inc.

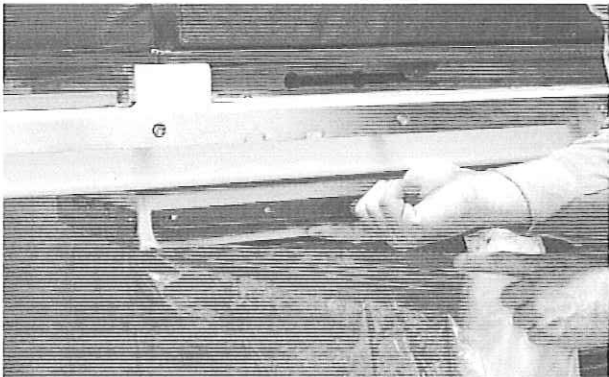

Figure 9. Lift the lower section of the strip on each side of the table, slide the plastic skirt underneath and lower the strip to hold the skirt in place.

Charging The Battery

This table can be operated with the power cord connected to an outlet or by using the battery. The battery recharges automatically while the table is plugged into an outlet even if the table is being used. An optional wall-mounted battery charger is also available.

SAFETY GUIDELINES



1. Secure restraining straps and ankle safety straps immediately after placing the patient on the table. The ankle safety straps prevent the patient from sliding off the table in the Trendelenburg position. The restraining straps prevent the patient from rolling off the side of the table.

NOTE: The restraining straps are not intended to restrain an uncontrolled patient.

2. Always lock the casters before moving a patient onto or off the table.
3. This table is rated to support patients weighing up to a maximum of 500 pounds.



CONSIGNES DE SECURITE

1. Fixer les lanières d'immobilisation et les lanières de cheville immédiatement après avoir placé le patient sur la table. Les lanières de cheville empêchent le patient de glisser sous la table en position de Trendelenburg. Les lanières d'immobilisation empêchent le patient de rouler par-dessus le côté de la table.

NOTA: Les lanières d'immobilisation n'ont pas pour objet l'immobilisation d'un patient hors de contrôle.

2. Toujours bloquer les roulettes avant de faire monter le patient sur la table ou de le faire descendre.
3. La table est certifiée comme pouvant supporter un patient pesant au plus 182 kg (400 lb).

Maintenance And Cleaning

This Biodex table is virtually maintenance free. By following the instructions below at suggested time intervals, or as often as necessary, your table will remain in "like new" condition.

1. As required, clean all exterior painted surfaces, tabletop and restraining straps with a mild detergent solution.
2. Wheels and wheel locks should remain free of foreign materials and dirt accumulation. Keeping wheel assemblies free of this matter will ensure smooth table transportation and free lock/unlock wheel operation.

NOTE: The Brachytherapy C-Arm Table is the same as the Urology C-Arm Table except it does not have the Drain Pan, Radiolucent Drain Bag Holder and Disposable Bags.

SPECIFICATIONS

058-800 Table, Urology C-Arm, 115 VAC
 058-805 Table, Urology C-Arm, 230 VAC
 058-810 Table, Brachytherapy, 115 VAC
 058-815 Table, Brachytherapy, 230 VAC

Dimensions: 84.5" l x 25.5" w (214.6 x 64.8 cm) with OR accessory rails

Tabletop: 53" l x 21" w (134.6 x 53.3 cm); 84" l (213.4 cm) with extension

Lightweight Extension (for patient transfer only, not for imaging): 26.5" l x 21" w (67.3 x 53.3 cm)

Radiolucent Extension: 31" l x 25.5" w (78.7 x 64.8 cm) with OR accessory rails

Radiolucent Area: 54" l x 17.5" w (137.2 x 44.5 cm)

Tabletop Material: Three Fibersin™ sections – each with individual 2" mattress

Table Sections: Four Sections: Adjustable Fowler Back 0° to 80°, abdominal section with cutout, radiolucent removable extension and a lightweight non-imaging transfer extension for transferring patients on and off the table

Mattress: Individual 2" thick (5 cm), one for each section

Motions:

Height: Adjustable from 34" to 43.5" (86.4 to 110.5 cm)

Tabletop X Motion (head-to-toe): 20" (51 cm)

Tabletop Y Motion (side-to-side): 10" (25.4 cm)

Trendelenburg: 0° to 20°

Reverse Trendelenburg: 0° to 20°

Lateral Roll: 0° to 20°

Fowler Back: Adjusts from 0° to 80° with touch handle lock/unlock

Controls:

Hand Control: activates all motions

Foot Control: activates all motions

Main Control Panel: LCD screen displays actual tabletop position (all axes) in real time, and provides menus and prompts for other functions

Joystick Controller: for motorized X-Y positioning

Optional:

X-Ray Film Tray: Removable film cassette tray for 14" x 17" film with cassette mask for 10" x 12" film. Film cassette tray can be removed from either side of the table.

X-Ray Grid: Removable X-Ray grid, 103 line, 8:1 ratio

Wheels:

Foot End – 3" (7.62 cm) individual locking swivel casters

Head End – 5" (6.4 cm) swivel casters with central locking

Accessory Rails: Standard OR accessory rails 1.125" x .375" (2.86 x .95 cm) on table (rails also on table imaging extension)

Patient Restraints: Two body straps, two ankle straps

Finish: Powder coat

Patient Capacity: 400 lb (181.4 kg); weight tested to four times the patient load rating.

Power: 115 VAC or 230 VAC and Battery. Battery automatically charges when table is plugged in. An additional battery can be charged with optional wall-mounted charger.

Standard Accessories:

- radiolucent extension
- transfer extension
- bellows skirt (disposable, 250/roll) and dispenser

Warranty: Two years

Certifications: ETL and cETL listed to UL-60601-1®, CAN/CSA® C22.2 No.: 601-1-M90, EN 60601-1, IEC 60601-1-2:2001-09

Optional:

056-851 Drain Bag Frame
 058-860 Drain Pain, Stainless Steel
 056-853 Crutch, Knee, Simplicity, (pair)
 058-862 Stirrups, PAL with boot pad (pair)
 058-865 Arm Board, Standard (pair)
 058-863 Arm Board, Dura Board with pad (pair)
 056-850 IV Pole, rail mounted
 056-862 Battery and Wall Charging Unit, 115 VAC
 056-863 Battery and Wall Charging Unit, 230 VAC
 056-463 Grid, X-ray, 103-line 8:1 ratio, 18" x 18"
 058-866 Cassette Tray Holder, 11" x 14"
 058-867 Extension Arm Controller

Replacement:

056-857 Drain Bags, Sterile, Disposable, 10/pkg
Fits 056-851 Drain Bag Frame
 056-460 Hose, Drain, Urology, 40/cs
 056-802 Bellows Skirt, disposable plastic, 250/roll
*Fits Surgical C-Arm Tables 840,
 Urology C-Arm Table and Brachytherapy Table*

Authorized European Community Representative:

PROTHIA
 26, rue serpollet
 75020 Paris, France
 (011)33.1.40.31.60.20