



State of West Virginia  
 Department of Administration  
 Purchasing Division  
 2019 Washington Street East  
 Post Office Box 50130  
 Charleston, WV 25305-0130

**Solicitation**

NUMBER
<b>GSD136427</b>

PAGE
<b>1</b>

ADDRESS CORRESPONDENCE TO ATTENTION OF:
<b>KRISTA FERRELL 304-558-2596</b>

VENDOR

**RFQ COPY  
 TYPE NAME/ADDRESS HERE**

Alpha Mechanical Service, Inc.  
 7200 Distribution Drive  
 Louisville, KY 40258-2827

SHIP TO

DEPARTMENT OF ADMINISTRATION  
 GENERAL SERVICES DIVISION  
 BUILDING 11 CHILLER PLANT  
 218 CALIFORNIA AVENUE  
 CHARLESTON, WV  
 25305 304-558-2317

DATE PRINTED
<b>01/23/2013</b>

BID OPENING DATE: **02/21/2013** BID OPENING TIME **01:30PM**

LINE	QUANTITY	UOP	CAT. NO.	ITEM NUMBER	UNIT PRICE	AMOUNT
0001	1	LS		031-13		
ANNUAL CLEANING AND MAINTENANCE OF TOWERS IN BLD 11						
REQUEST FOR QUOTATION (RFQ)						
THE WEST VIRGINIA STATE PURCHASING DIVISION FOR THE AGENCY, THE WEST VIRGINIA DIVISION OF GENERAL SERVICES, IS SOLICITING BIDS TO PROVIDE THE AGENCY WITH ALL LABOR, MATERIALS, EQUIPMENT, AND SUPPLIES TO PERFORM ANNUAL CLEANING AND MAINTENANCE ON THE CHILLERS AND TOWERS LOCATED IN BUILDING 11 ON THE WEST VIRGINIA STATE CAPITOL COMPLEX IN CHARLESTON, WEST VIRGINIA PER THE ATTACHED SPECIFICATIONS.						
***** THIS IS THE END OF RFQ GSD136427 ***** TOTAL:						\$36,420.00
						02/21/13 09:58:02 AM West Virginia Purchasing Division

SIGNATURE <i>Herman J. Rhodes, Jr.</i>	TELEPHONE (502) 968-0121	DATE February 20, 2013
TITLE President	FEIN 51-0456396	ADDRESS CHANGES TO BE NOTED ABOVE

WHEN RESPONDING TO SOLICITATION, INSERT NAME AND ADDRESS IN SPACE ABOVE LABELED 'VENDOR'

**INSTRUCTIONS TO VENDORS SUBMITTING BIDS**

1. **REVIEW DOCUMENTS THOROUGHLY:** The attached documents contain a solicitation for bids. Please read these instructions and all documents attached in their entirety. These instructions provide critical information about requirements that if overlooked could lead to disqualification of a Vendor's bid. All bids must be submitted in accordance with the provisions contained in these instructions and the Solicitation. Failure to do so may result in disqualification of Vendor's bid.
2. **MANDATORY TERMS:** The Solicitation may contain mandatory provisions identified by the use of the words "must," "will," and "shall." Failure to comply with a mandatory term in the Solicitation will result in bid disqualification.
3. **PREBID MEETING:** The item identified below shall apply to this Solicitation.

| A pre-bid meeting will not be held prior to bid opening.

| A **NON-MANDATORY PRE-BID** meeting will be held at the following place and time:

| A **MANDATORY PRE-BID** meeting will be held at the following place and time:

February 5, 2013 at 10:00 am in the conference room of Building 11 located at the corner of Piedmont Avenue and California Avenue on the West Virginia State Capitol Complex in Charleston, West Virginia.  
 Parking in and around the West Virginia Capitol Complex is limited. Vendors are encouraged to allow adequate time to secure parking.

All Vendors submitting a bid must attend the mandatory pre-bid meeting. Failure to attend the mandatory pre-bid meeting shall result in disqualification of the Vendor's bid. No one person attending the pre-bid meeting may represent more than one Vendor.

An attendance sheet provided at the pre-bid meeting shall serve as the official document verifying attendance. The State will not accept any other form of proof or documentation to verify attendance. Any person attending the pre-bid meeting on behalf of a Vendor must list on the attendance sheet his or her name and the name of the Vendor he or she is representing. Additionally, the person attending the pre-bid meeting should include the Vendor's E-Mail address, phone number, and Fax number on the attendance sheet. It is the Vendor's responsibility to locate the attendance sheet and provide the required

information. Failure to complete the attendance sheet as required may result in disqualification of Vendor's bid.

All Vendors should arrive prior to the starting time for the pre-bid. Vendors who arrive after the starting time but prior to the end of the pre-bid will be permitted to sign in, but are charged with knowing all matters discussed at the pre-bid.

Questions submitted at least five business days prior to a scheduled pre-bid will be discussed at the pre-bid meeting if possible. Any discussions or answers to questions at the pre-bid meeting are preliminary in nature and are non-binding. Official and binding answers to questions will be published in a written addendum to the Solicitation prior to bid opening.

- 4. **VENDOR QUESTION DEADLINE:** Vendors may submit questions relating to this Solicitation to the Purchasing Division. Questions must be submitted in writing. All questions must be submitted on or before the date listed below and to the address listed below in order to be considered. A written response will be published in a Solicitation addendum if a response is possible and appropriate. Non-written discussions, conversations, or questions and answers regarding this Solicitation are preliminary in nature and are non-binding.

Question Submission Deadline: February 8, 2013 at 5:00 PM EST

Submit Questions to:

Krista S. Ferrell, Buyer Supervisor  
 2019 Washington Street, East  
 P.O. Box 50130  
 Charleston, WV 25305  
 Fax: 304-558-4115  
 Email: krista.s.ferrell@wv.gov

- 5. **VERBAL COMMUNICATION:** Any verbal communication between the Vendor and any State personnel is not binding, including that made at the mandatory pre-bid conference. Only information issued in writing and added to the Solicitation by an official written addendum by the Purchasing Division is binding.
- 6. **BID SUBMISSION:** All bids must be signed and delivered by the Vendor to the Purchasing Division at the address listed below on or before the date and time of the bid opening. Any bid received by the Purchasing Division staff is considered to be in the possession of the Purchasing Division and will not be returned for any reason. The bid delivery address is:

Department of Administration, Purchasing Division  
 2019 Washington Street East  
 P.O. Box 50130,  
 Charleston, WV 25305-0130

The bid should contain the information listed below on the face of the envelope or the bid may not be considered:

SEALED BID

BUYER: \_\_\_\_\_  
SOLICITATION NO.: \_\_\_\_\_  
BID OPENING DATE: \_\_\_\_\_  
BID OPENING TIME: \_\_\_\_\_  
FAX NUMBER: \_\_\_\_\_

In the event that Vendor is responding to a request for proposal, the Vendor shall submit one original technical and one original cost proposal plus  n/a  convenience copies of each to the Purchasing Division at the address shown above. Additionally, the Vendor should identify the bid type as either a technical or cost proposal on the face of each bid envelope submitted in response to a request for proposal as follows:

BID TYPE:     | Technical  
                   | Cost

- 7. **BID OPENING:** Bids submitted in response to this Solicitation will be opened at the location identified below on the date and time listed below. Delivery of a bid after the bid opening date and time will result in bid disqualification. For purposes of this Solicitation, a bid is considered delivered when time stamped by the official Purchasing Division time clock.

Bid Opening Date and Time:

February 21, 2013 at 1:30 PM EST

Bid Opening Location:

Department of Administration, Purchasing Division  
2019 Washington Street East  
P.O. Box 50130,  
Charleston, WV 25305-0130

- 8. **ADDENDUM ACKNOWLEDGEMENT:** Changes or revisions to this Solicitation will be made by an official written addendum issued by the Purchasing Division. Vendor should acknowledge receipt of all addenda issued with this Solicitation by completing an Addendum Acknowledgment Form, a copy of which is included herewith. Failure to acknowledge addenda may result in bid disqualification. The addendum acknowledgement should be submitted with the bid to expedite document processing.
- 9. **BID FORMATTING:** Vendor should type or electronically enter the information onto its bid to prevent errors in the evaluation. Failure to type or electronically enter the information may result in bid disqualification.



**GENERAL TERMS AND CONDITIONS:**

1. **CONTRACTUAL AGREEMENT:** Issuance of a Purchase Order signed by the Purchasing Division Director, or his designee, and approved as to form by the Attorney General's office constitutes acceptance of this Contract made by and between the State of West Virginia and the Vendor. Vendor's signature on its bid signifies Vendor's agreement to be bound by and accept the terms and conditions contained in this Contract.
  
2. **DEFINITIONS:** As used in this Solicitation / Contract, the following terms shall have the meanings attributed to them below. Additional definitions may be found in the specifications included with this Solicitation / Contract.
  - 2.1 "Agency" or "Agencies" means the agency, board, commission, or other entity of the State of West Virginia that is identified on the first page of the Solicitation or any other public entity seeking to procure goods or services under this Contract.
  - 2.2 "Contract" means the binding agreement that is entered into between the State and the Vendor to provide the goods and services requested in the Solicitation.
  - 2.3 "Director" means the Director of the West Virginia Department of Administration, Purchasing Division.
  - 2.4 "Purchasing Division" means the West Virginia Department of Administration, Purchasing Division.
  - 2.5 "Purchase Order" means the document signed by the Agency and the Purchasing Division, and approved as to form by the Attorney General, that identifies the Vendor as the successful bidder and Contract holder.
  - 2.6 "Solicitation" means the official solicitation published by the Purchasing Division and identified by number on the first page thereof.
  - 2.7 "State" means the State of West Virginia and/or any of its agencies, commissions, boards, etc. as context requires.
  - 2.8 "Vendor" or "Vendors" means any entity submitting a bid in response to the Solicitation, the entity that has been selected as the lowest responsible bidder, or the entity that has been awarded the Contract as context requires.

3. **CONTRACT TERM; RENEWAL; EXTENSION:** The term of this Contract shall be determined in accordance with the category that has been identified as applicable to this Contract below:

| **Term Contract**

**Initial Contract Term:** This Contract becomes effective on   
  
 and extends for a period of  year(s).

**Renewal Term:** This Contract may be renewed upon the mutual written consent of the Agency, and the Vendor, with approval of the Purchasing Division and the Attorney General's office (Attorney General approval is as to form only). Any request for renewal must be submitted to the Purchasing Division Director thirty (30) days prior to the expiration date of the initial contract term or appropriate renewal term. A Contract renewal shall be in accordance with the terms and conditions of the original contract. Renewal of this Contract is limited to  successive one (1) year periods. Automatic renewal of this Contract is prohibited. Notwithstanding the foregoing, Purchasing Division approval is not required on agency delegated or exempt purchases. Attorney General approval may be required for vendor terms and conditions.

**Reasonable Time Extension:** At the sole discretion of the Purchasing Division Director, and with approval from the Attorney General's office (Attorney General approval is as to form only), this Contract may be extended for a reasonable time after the initial Contract term or after any renewal term as may be necessary to obtain a new contract or renew this Contract. Any reasonable time extension shall not exceed twelve (12) months. Vendor may avoid a reasonable time extension by providing the Purchasing Division Director with written notice of Vendor's desire to terminate this Contract 30 days prior to the expiration of the then current term. During any reasonable time extension period, the Vendor may terminate this Contract for any reason upon giving the Purchasing Division Director 30 days written notice. Automatic extension of this Contract is prohibited. Notwithstanding the foregoing, Purchasing Division approval is not required on agency delegated or exempt purchases, but Attorney General approval may be required.

- | **Fixed Period Contract:** This Contract becomes effective upon Vendor's receipt of the notice to proceed and must be completed within  60 calendar days  days.
- | **One Time Purchase:** The term of this Contract shall run from the issuance of the Purchase Order until all of the goods contracted for have been delivered, but in no event shall this Contract extend for more than one fiscal year.
- | **Other:** See attached.

4. **NOTICE TO PROCEED:** Vendor shall begin performance of this Contract immediately upon receiving notice to proceed unless otherwise instructed by the Agency. Unless otherwise specified, the fully executed Purchase Order will be considered notice to proceed
5. **QUANTITIES:** The quantities required under this Contract shall be determined in accordance with the category that has been identified as applicable to this Contract below.
- | **Open End Contract:** Quantities listed in this Solicitation are approximations only, based on estimates supplied by the Agency. It is understood and agreed that the Contract shall cover the quantities actually ordered for delivery during the term of the Contract, whether more or less than the quantities shown.
  - | **Service:** The scope of the service to be provided will be more clearly defined in the specifications included herewith.
  - | **Combined Service and Goods:** The scope of the service and deliverable goods to be provided will be more clearly defined in the specifications included herewith.
  - | **One Time Purchase:** This Contract is for the purchase of a set quantity of goods that are identified in the specifications included herewith. Once those items have been delivered, no additional goods may be procured under this Contract without an appropriate change order approved by the Vendor, Agency, Purchasing Division, and Attorney General's office.
6. **PRICING:** The pricing set forth herein is firm for the life of the Contract, unless specified elsewhere within this Solicitation/Contract by the State. A Vendor's inclusion of price adjustment provisions in its bid, without an express authorization from the State in the Solicitation to do so, may result in bid disqualification.
7. **EMERGENCY PURCHASES:** The Purchasing Division Director may authorize the Agency to purchase goods or services in the open market that Vendor would otherwise provide under this Contract if those goods or services are for immediate or expedited delivery in an emergency. Emergencies shall include, but are not limited to, delays in transportation or an unanticipated increase in the volume of work. An emergency purchase in the open market, approved by the Purchasing Division Director, shall not constitute of breach of this Contract and shall not entitle the Vendor to any form of compensation or damages. This provision does not excuse the State from fulfilling its obligations under a One Time Purchase contract.
8. **REQUIRED DOCUMENTS:** All of the items checked below must be provided to the Purchasing Division by the Vendor as specified below.
- | **BID BOND:** All Vendors shall furnish a bid bond in the amount of five percent (5%) of the total amount of the bid protecting the State of West Virginia. The bid bond must be submitted with the bid.

**PERFORMANCE BOND:** The apparent successful Vendor shall provide a performance bond in the amount of . The performance bond must be issued and received by the Purchasing Division prior to Contract award. On construction contracts, the performance bond must be 100% of the Contract value.

**LABOR/MATERIAL PAYMENT BOND:** The apparent successful Vendor shall provide a labor/material payment bond in the amount of 100% of the Contract value. The labor/material payment bond must be issued and delivered to the Purchasing Division prior to Contract award.

In lieu of the Bid Bond, Performance Bond, and Labor/Material Payment Bond, the Vendor may provide certified checks, cashier's checks, or irrevocable letters of credit. Any certified check, cashier's check, or irrevocable letter of credit provided in lieu of a bond must be of the same amount and delivered on the same schedule as the bond it replaces. A letter of credit submitted in lieu of a performance and labor/material payment bond will only be allowed for projects under \$100,000. Personal or business checks are not acceptable.

**MAINTENANCE BOND:** The apparent successful Vendor shall provide a two (2) year maintenance bond covering the roofing system. The maintenance bond must be issued and delivered to the Purchasing Division prior to Contract award.

**WORKERS' COMPENSATION INSURANCE:** The apparent successful Vendor shall have appropriate workers' compensation insurance and shall provide proof thereof upon request.

**INSURANCE:** The apparent successful Vendor shall furnish proof of the following insurance prior to Contract award:

**Commercial General Liability Insurance:**  
 or more.

**Builders Risk Insurance:** builders risk – all risk insurance in an amount equal to 100% of the amount of the Contract.

<input type="checkbox"/>	<input type="text"/>
<input type="checkbox"/>	<input type="text"/>
<input type="checkbox"/>	<input type="text"/>
<input type="checkbox"/>	<input type="text"/>
<input type="checkbox"/>	<input type="text"/>

The apparent successful Vendor shall also furnish proof of any additional insurance requirements contained in the specifications prior to Contract award regardless of whether or not that insurance requirement is listed above.

| | **LICENSE(S) / CERTIFICATIONS / PERMITS:** In addition to anything required under the Section entitled Licensing, of the General Terms and Conditions, the apparent successful Vendor shall furnish proof of the following licenses, certifications, and/or permits prior to Contract award, in a form acceptable to the Purchasing Division.

[	
[	
[	
[	

The apparent successful Vendor shall also furnish proof of any additional licenses or certifications contained in the specifications prior to Contract award regardless of whether or not that requirement is listed above.

**9. LITIGATION BOND:** The Director reserves the right to require any Vendor that files a protest of an award to submit a litigation bond in the amount equal to one percent of the lowest bid submitted or \$5,000, whichever is greater. The entire amount of the bond shall be forfeited if the hearing officer determines that the protest was filed for frivolous or improper purpose, including but not limited to, the purpose of harassing, causing unnecessary delay, or needless expense for the Agency. All litigation bonds shall be made payable to the Purchasing Division. In lieu of a bond, the protester may submit a cashier's check or certified check payable to the Purchasing Division. Cashier's or certified checks will be deposited with and held by the State Treasurer's office. If it is determined that the protest has not been filed for frivolous or improper purpose, the bond or deposit shall be returned in its entirety.

**10. ALTERNATES:** Any model, brand, or specification listed herein establishes the acceptable level of quality only and is not intended to reflect a preference for, or in any way favor, a particular brand or vendor. Vendors may bid alternates to a listed model or brand provided that the alternate is at least equal to the model or brand and complies with the required specifications. The equality of any alternate being bid shall be determined by the State at its sole discretion. Any Vendor bidding an alternate model or brand should clearly identify the alternate items in its bid and should include manufacturer's specifications, industry literature, and/or any other relevant documentation demonstrating the equality of the alternate items. Failure to provide information for alternate items may be grounds for rejection of a Vendor's bid.

**11. EXCEPTIONS AND CLARIFICATIONS:** The Solicitation contains the specifications that shall form the basis of a contractual agreement. Vendor shall clearly mark any exceptions, clarifications, or

other proposed modifications in its bid. Exceptions to, clarifications of, or modifications of a requirement or term and condition of the Solicitation may result in bid disqualification.

**12. LIQUIDATED DAMAGES:** Vendor shall pay liquidated damages in the amount

\$500.00 per day for failure to complete

This clause shall in no way be considered exclusive and shall not limit the State or Agency's right to pursue any other available remedy.

**13. ACCEPTANCE/REJECTION:** The State may accept or reject any bid in whole, or in part. Vendor's signature on its bid signifies acceptance of the terms and conditions contained in the Solicitation and Vendor agrees to be bound by the terms of the Contract, as reflected in the Purchase Order, upon receipt.

**14. REGISTRATION:** Prior to Contract award, the apparent successful Vendor must be properly registered with the West Virginia Purchasing Division and must have paid the \$125 fee if applicable.

**15. COMMUNICATION LIMITATIONS:** In accordance with West Virginia Code of State Rules §148-1-6.6, communication with the State of West Virginia or any of its employees regarding this Solicitation during the solicitation, bid, evaluation or award periods, except through the Purchasing Division, is strictly prohibited without prior Purchasing Division approval. Purchasing Division approval for such communication is implied for all agency delegated and exempt purchases.

**16. FUNDING:** This Contract shall continue for the term stated herein, contingent upon funds being appropriated by the Legislature or otherwise being made available. In the event funds are not appropriated or otherwise made available, this Contract becomes void and of no effect beginning on July 1 of the fiscal year for which funding has not been appropriated or otherwise made available.

**17. PAYMENT:** Payment in advance is prohibited under this Contract. Payment may only be made after the delivery and acceptance of goods or services. The Vendor shall submit invoices, in arrears, to the Agency at the address on the face of the purchase order labeled "Invoice To."

**18. UNIT PRICE:** Unit prices shall prevail in cases of a discrepancy in the Vendor's bid.

**19. DELIVERY:** All quotations are considered freight on board destination ("F.O.B. destination") unless alternate shipping terms are clearly identified in the bid. Vendor's listing of shipping terms that contradict the shipping terms expressly required by this Solicitation may result in bid disqualification.

**20. INTEREST:** Interest attributable to late payment will only be permitted if authorized by the West Virginia Code. Presently, there is no provision in the law for interest on late payments.

**21. PREFERENCE:** Vendor Preference may only be granted upon written request and only in accordance with the West Virginia Code § 5A-3-37 and the West Virginia Code of State Rules. A Resident Vendor Certification form has been attached hereto to allow Vendor to apply for the preference. Vendor's



failure to submit the Resident Vendor Certification form with its bid will result in denial of Vendor Preference. Vendor Preference does not apply to construction projects.

22. **SMALL, WOMEN-OWNED, OR MINORITY-OWNED BUSINESSES:** For any solicitations publicly advertised for bid on or after July 1, 2012, in accordance with West Virginia Code §5A-3-37(a)(7) and W. Va. CSR § 148-22-9, any non-resident vendor certified as a small, women-owned, or minority-owned business under W. Va. CSR § 148-22-9 shall be provided the same preference made available to any resident vendor. Any non-resident small, women-owned, or minority-owned business must identify itself as such in writing, must submit that writing to the Purchasing Division with its bid, and must be properly certified under W. Va. CSR § 148-22-9 prior to submission of its bid to receive the preferences made available to resident vendors. Preference for a non-resident small, women-owned, or minority owned business shall be applied in accordance with W. Va. CSR § 148-22-9.
23. **TAXES:** The Vendor shall pay any applicable sales, use, personal property or any other taxes arising out of this Contract and the transactions contemplated thereby. The State of West Virginia is exempt from federal and state taxes and will not pay or reimburse such taxes.
24. **CANCELLATION:** The Purchasing Division Director reserves the right to cancel this Contract immediately upon written notice to the vendor if the materials or workmanship supplied do not conform to the specifications contained in the Contract. The Purchasing Division Director may cancel any purchase or Contract upon 30 days written notice to the Vendor in accordance with West Virginia Code of State Rules § 148-1-7.16.2.
25. **WAIVER OF MINOR IRREGULARITIES:** The Director reserves the right to waive minor irregularities in bids or specifications in accordance with West Virginia Code of State Rules § 148-1-4.6.
26. **TIME:** Time is of the essence with regard to all matters of time and performance in this Contract.
27. **APPLICABLE LAW:** This Contract is governed by and interpreted under West Virginia law without giving effect to its choice of law principles. Any information provided in specification manuals, or any other source, verbal or written, which contradicts or violates the West Virginia Constitution, West Virginia Code or West Virginia Code of State Rules is void and of no effect.
28. **COMPLIANCE:** Vendor shall comply with all applicable federal, state, and local laws, regulations and ordinances. By submitting a bid, Vendors acknowledge that they have reviewed, understand, and will comply with all applicable law.
29. **PREVAILING WAGE:** On any contract for the construction of a public improvement, Vendor and any subcontractors utilized by Vendor shall pay a rate or rates of wages which shall not be less than the fair minimum rate or rates of wages (prevailing wage), as established by the West Virginia Division of Labor under West Virginia Code §§ 21-5A-1 et seq. and available at <http://www.sos.wv.gov/administrative-law/wagerates/Pages/default.aspx>. Vendor shall be responsible for ensuring compliance with prevailing wage requirements and determining when prevailing wage

requirements are applicable. The required contract provisions contained in West Virginia Code of State Rules § 42-7-3 are specifically incorporated herein by reference.

- 30. ARBITRATION:** Any references made to arbitration contained in this Contract, Vendor's bid, or in any American Institute of Architects documents pertaining to this Contract are hereby deleted, void, and of no effect.
- 31. MODIFICATIONS:** This writing is the parties' final expression of intent. Notwithstanding anything contained in this Contract to the contrary, no modification of this Contract shall be binding without mutual written consent of the Agency, and the Vendor, with approval of the Purchasing Division and the Attorney General's office (Attorney General approval is as to form only). **No Change shall be implemented by the Vendor until such time as the Vendor receives an approved written change order from the Purchasing Division.**
- 32. WAIVER:** The failure of either party to insist upon a strict performance of any of the terms or provision of this Contract, or to exercise any option, right, or remedy herein contained, shall not be construed as a waiver or a relinquishment for the future of such term, provision, option, right, or remedy, but the same shall continue in full force and effect. Any waiver must be expressly stated in writing and signed by the waiving party.
- 33. SUBSEQUENT FORMS:** The terms and conditions contained in this Contract shall supersede any and all subsequent terms and conditions which may appear on any form documents submitted by Vendor to the Agency or Purchasing Division such as price lists, order forms, invoices, sales agreements, or maintenance agreements, and includes internet websites or other electronic documents. Acceptance or use of Vendor's forms does not constitute acceptance of the terms and conditions contained thereon.
- 34. ASSIGNMENT:** Neither this Contract nor any monies due, or to become due hereunder, may be assigned by the Vendor without the express written consent of the Agency, the Purchasing Division, the Attorney General's office (as to form only), and any other government agency or office that may be required to approve such assignments. Notwithstanding the foregoing, Purchasing Division approval may or may not be required on certain agency delegated or exempt purchases.
- 35. WARRANTY:** The Vendor expressly warrants that the goods and/or services covered by this Contract will: (a) conform to the specifications, drawings, samples, or other description furnished or specified by the Agency; (b) be merchantable and fit for the purpose intended; and (c) be free from defect in material and workmanship.
- 36. STATE EMPLOYEES:** State employees are not permitted to utilize this Contract for personal use and the Vendor is prohibited from permitting or facilitating the same.
- 37. BANKRUPTCY:** In the event the Vendor files for bankruptcy protection, the State of West Virginia may deem this Contract null and void, and terminate this Contract without notice.

- 38. HIPAA BUSINESS ASSOCIATE ADDENDUM:** The West Virginia State Government HIPAA Business Associate Addendum (BAA), approved by the Attorney General, is available online at <http://www.state.wv.us/admin/purchase/vrc/hipaa.html> and is hereby made part of the agreement provided that the Agency meets the definition of a Covered entity (45 CFR §160.103) and will be disclosing Protected Health Information (45 CFR §160.103) to the Vendor.
- 39. CONFIDENTIALITY:** The Vendor agrees that it will not disclose to anyone, directly or indirectly, any such personally identifiable information or other confidential information gained from the Agency, unless the individual who is the subject of the information consents to the disclosure in writing or the disclosure is made pursuant to the Agency's policies, procedures, and rules. Vendor further agrees to comply with the Confidentiality Policies and Information Security Accountability Requirements, set forth in <http://www.state.wv.us/admin/purchase/privacy/default.html>.
- 40. DISCLOSURE:** Vendor's response to the Solicitation and the resulting Contract are considered public documents and will be disclosed to the public in accordance with the laws, rules, and policies governing the West Virginia Purchasing Division. Those laws include, but are not limited to, the Freedom of Information Act found in West Virginia Code § 29B-1-1 et seq.

If a Vendor considers any part of its bid to be exempt from public disclosure, Vendor must so indicate by specifically identifying the exempt information, identifying the exemption that applies, providing a detailed justification for the exemption, segregating the exempt information from the general bid information, and submitting the exempt information as part of its bid but in a segregated and clearly identifiable format. Failure to comply with the foregoing requirements will result in public disclosure of the Vendor's bid without further notice. A Vendor's act of marking all or nearly all of its bid as exempt is not sufficient to avoid disclosure and WILL NOT BE HONORED. Vendor's act of marking a bid or any part thereof as "confidential" or "proprietary" is not sufficient to avoid disclosure and WILL NOT BE HONORED. In addition, a legend or other statement indicating that all or substantially all of the bid is exempt from disclosure is not sufficient to avoid disclosure and WILL NOT BE HONORED. Vendor will be required to defend any claimed exemption for nondisclosure in the event of an administrative or judicial challenge to the State's nondisclosure. Vendor must indemnify the State for any costs incurred related to any exemptions claimed by Vendor. Any questions regarding the applicability of the various public records laws should be addressed to your own legal counsel prior to bid submission.

- 41. LICENSING:** In accordance with West Virginia Code of State Rules §148-1-6.1.7, Vendor must be licensed and in good standing in accordance with any and all state and local laws and requirements by any state or local agency of West Virginia, including, but not limited to, the West Virginia Secretary of State's Office, the West Virginia Tax Department, West Virginia Insurance Commission, or any other state agency or political subdivision. Upon request, the Vendor must provide all necessary releases to obtain information to enable the Purchasing Division Director or the Agency to verify that the Vendor is licensed and in good standing with the above entities.

- 42. ANTITRUST:** In submitting a bid to, signing a contract with, or accepting a Purchase Order from any agency of the State of West Virginia, the Vendor agrees to convey, sell, assign, or transfer to the State of West Virginia all rights, title, and interest in and to all causes of action it may now or hereafter acquire under the antitrust laws of the United States and the State of West Virginia for price fixing and/or unreasonable restraints of trade relating to the particular commodities or services purchased or acquired by the State of West Virginia. Such assignment shall be made and become effective at the time the purchasing agency tenders the initial payment to Vendor.
- 43. VENDOR CERTIFICATIONS:** By signing its bid or entering into this Contract, Vendor certifies (1) that its bid was made without prior understanding, agreement, or connection with any corporation, firm, limited liability company, partnership, person or entity submitting a bid for the same material, supplies, equipment or services; (2) that its bid is in all respects fair and without collusion or fraud; (3) that this Contract is accepted or entered into without any prior understanding, agreement, or connection to any other entity that could be considered a violation of law; and (4) that it has reviewed this RFQ in its entirety; understands the requirements, terms and conditions, and other information contained herein. Vendor's signature on its bid also affirms that neither it nor its representatives have any interest, nor shall acquire any interest, direct or indirect, which would compromise the performance of its services hereunder. Any such interests shall be promptly presented in detail to the Agency.

The individual signing this bid on behalf of Vendor certifies that he or she is authorized by the Vendor to execute this bid or any documents related thereto on Vendor's behalf; that he or she is authorized to bind the Vendor in a contractual relationship; and that, to the best of his or her knowledge, the Vendor has properly registered with any State agency that may require registration.

- 44. PURCHASING CARD ACCEPTANCE:** The State of West Virginia currently utilizes a Purchasing Card program, administered under contract by a banking institution, to process payment for goods and services. The Vendor must accept the State of West Virginia's Purchasing Card for payment of all orders under this Contract unless the box below is checked.

Vendor is not required to accept the State of West Virginia's Purchasing Card as payment for all goods and services.

- 45. VENDOR RELATIONSHIP:** The relationship of the Vendor to the State shall be that of an independent contractor and no principal-agent relationship or employer-employee relationship is contemplated or created by this Contract. The Vendor as an independent contractor is solely liable for the acts and omissions of its employees and agents. Vendor shall be responsible for selecting, supervising, and compensating any and all individuals employed pursuant to the terms of this Solicitation and resulting contract. Neither the Vendor, nor any employees or subcontractors of the Vendor, shall be deemed to be employees of the State for any purpose whatsoever. Vendor shall be exclusively responsible for payment of employees and contractors for all wages and salaries, taxes, withholding payments, penalties, fees, fringe benefits, professional liability insurance premiums, contributions to insurance and pension, or other deferred compensation plans, including but not limited to, Workers' Compensation and Social Security obligations, licensing fees, *etc.* and the filing of all necessary documents, forms and returns pertinent to all of the foregoing. Vendor shall hold harmless the

State, and shall provide the State and Agency with a defense against any and all claims including, but not limited to, the foregoing payments, withholdings, contributions, taxes, Social Security taxes, and employer income tax returns.

- 46. INDEMNIFICATION:** The Vendor agrees to indemnify, defend, and hold harmless the State and the Agency, their officers, and employees from and against: (1) Any claims or losses for services rendered by any subcontractor, person, or firm performing or supplying services, materials, or supplies in connection with the performance of the Contract; (2) Any claims or losses resulting to any person or entity injured or damaged by the Vendor, its officers, employees, or subcontractors by the publication, translation, reproduction, delivery, performance, use, or disposition of any data used under the Contract in a manner not authorized by the Contract, or by Federal or State statutes or regulations; and (3) Any failure of the Vendor, its officers, employees, or subcontractors to observe State and Federal laws including, but not limited to, labor and wage and hour laws.
- 47. PURCHASING AFFIDAVIT:** In accordance with West Virginia Code § 5A-3-10a, all Vendors are required to sign, notarize, and submit the Purchasing Affidavit stating that neither the Vendor nor a related party owe a debt to the State in excess of \$1,000. The affidavit must be submitted prior to award, but should be submitted with the Vendor's bid. A copy of the Purchasing Affidavit is included herewith.
- 48. ADDITIONAL AGENCY AND LOCAL GOVERNMENT USE:** This Contract may be utilized by and extends to other agencies, spending units, and political subdivisions of the State of West Virginia; county, municipal, and other local government bodies; and school districts ("Other Government Entities"). This Contract shall be extended to the aforementioned Other Government Entities on the same prices, terms, and conditions as those offered and agreed to in this Contract. If the Vendor does not wish to extend the prices, terms, and conditions of its bid and subsequent contract to the Other Government Entities, the Vendor must clearly indicate such refusal in its bid. A refusal to extend this Contract to the Other Government Entities shall not impact or influence the award of this Contract in any manner.
- 49. CONFLICT OF INTEREST:** Vendor, its officers or members or employees, shall not presently have or acquire any interest, direct or indirect, which would conflict with or compromise the performance of its obligations hereunder. Vendor shall periodically inquire of its officers, members and employees to ensure that a conflict of interest does not arise. Any conflict of interest discovered shall be promptly presented in detail to the Agency.
- 50. REPORTS:** Vendor shall provide the Agency and/or the Purchasing Division with the following reports identified by a checked box below:
- Such reports as the Agency and/or the Purchasing Division may request. Requested reports may include, but are not limited to, quantities purchased, agencies utilizing the contract, total contract expenditures by agency, etc.



- | | Quarterly reports detailing the total quantity of purchases in units and dollars, along with a listing of purchases by agency. Quarterly reports should be delivered to the Purchasing Division via email at [purchasing.requisitions@wv.gov](mailto:purchasing.requisitions@wv.gov).

**51. BACKGROUND CHECK:** In accordance with W. Va. Code § 15-2D-3, the Director of the Division of Protective Services shall require any service provider whose employees are regularly employed on the grounds or in the buildings of the Capitol complex or who have access to sensitive or critical information to submit to a fingerprint-based state and federal background inquiry through the state repository. The service provider is responsible for any costs associated with the fingerprint-based state and federal background inquiry.

After the contract for such services has been approved, but before any such employees are permitted to be on the grounds or in the buildings of the Capitol complex or have access to sensitive or critical information, the service provider shall submit a list of all persons who will be physically present and working at the Capitol complex to the Director of the Division of Protective Services for purposes of verifying compliance with this provision.

The State reserves the right to prohibit a service provider's employees from accessing sensitive or critical information or to be present at the Capitol complex based upon results addressed from a criminal background check.

Service providers should contact the West Virginia Division of Protective Services by phone at (304) 558-9911 for more information.

**52. PREFERENCE FOR USE OF DOMESTIC STEEL PRODUCTS:** Except when authorized by the Director of the Purchasing Division pursuant to W. Va. Code § 5A-3-56, no contractor may use or supply steel products for a State Contract Project other than those steel products made in the United States. A contractor who uses steel products in violation of this section may be subject to civil penalties pursuant to W. Va. Code § 5A-3-56. As used in this section:

- a. "State Contract Project" means any erection or construction of, or any addition to, alteration of or other improvement to any building or structure, including, but not limited to, roads or highways, or the installation of any heating or cooling or ventilating plants or other equipment, or the supply of and materials for such projects, pursuant to a contract with the State of West Virginia for which bids were solicited on or after June 6, 2001.
- b. "Steel Products" means products rolled, formed, shaped, drawn, extruded, forged, cast, fabricated or otherwise similarly processed, or processed by a combination of two or more or such operations, from steel made by the open hearth, basic oxygen, electric furnace, Bessemer or other steel making process.

The Purchasing Division Director may, in writing, authorize the use of foreign steel products if:

- a. The cost for each contract item used does not exceed one tenth of one percent (.1%) of the total



contract cost or two thousand five hundred dollars (\$2,500.00), whichever is greater. For the purposes of this section, the cost is the value of the steel product as delivered to the project; or

- b. The Director of the Purchasing Division determines that specified steel materials are not produced in the United States in sufficient quantity or otherwise are not reasonably available to meet contract requirements.

**53. PREFERENCE FOR USE OF DOMESTIC ALUMINUM, GLASS, AND STEEL:** In Accordance with W. Va. Code § 5-19-1 et seq., and W. Va. CSR § 148-10-1 et seq., for every contract or subcontract, subject to the limitations contained herein, for the construction, reconstruction, alteration, repair, improvement or maintenance of public works or for the purchase of any item of machinery or equipment to be used at sites of public works, only domestic aluminum, glass or steel products shall be supplied unless the spending officer determines, in writing, after the receipt of offers or bids, (1) that the cost of domestic aluminum, glass or steel products is unreasonable or inconsistent with the public interest of the State of West Virginia, (2) that domestic aluminum, glass or steel products are not produced in sufficient quantities to meet the contract requirements, or (3) the available domestic aluminum, glass, or steel do not meet the contract specifications. This provision only applies to public works contracts awarded in an amount more than fifty thousand dollars (\$50,000) or public works contracts that require more than ten thousand pounds of steel products.

The cost of domestic aluminum, glass, or steel products may be unreasonable if the cost is more than twenty percent (20%) of the bid or offered price for foreign made aluminum, glass, or steel products. If the domestic aluminum, glass or steel products to be supplied or produced in a "substantial labor surplus area", as defined by the United States Department of Labor, the cost of domestic aluminum, glass, or steel products may be unreasonable if the cost is more than thirty percent (30%) of the bid or offered price for foreign made aluminum, glass, or steel products.

This preference shall be applied to an item of machinery or equipment, as indicated above, when the item is a single unit of equipment or machinery manufactured primarily of aluminum, glass or steel, is part of a public works contract and has the sole purpose or of being a permanent part of a single public works project. This provision does not apply to equipment or machinery purchased by a spending unit for use by that spending unit and not as part of a single public works project.

All bids and offers including domestic aluminum, glass or steel products that exceed bid or offer prices including foreign aluminum, glass or steel products after application of the preferences provided in this provision may be reduced to a price equal to or lower than the lowest bid or offer price for foreign aluminum, glass or steel products plus the applicable preference. If the reduced bid or offer prices are made in writing and supersede the prior bid or offer prices, all bids or offers, including the reduced bid or offer prices, will be reevaluated in accordance with this rule.

**ADDITIONAL TERMS AND CONDITIONS (Construction Contracts Only)**

1. **CONTRACTOR'S LICENSE:** West Virginia Code § 21-11-2 requires that all persons desiring to perform contracting work in this state be licensed. The West Virginia Contractors Licensing Board is empowered to issue the contractor's license. Applications for a contractor's license may be made by contacting the West Virginia Division of Labor.

West Virginia Code § 21-11-11 requires any prospective Vendor to include the contractor's license number on its bid. Failure to include a contractor's license number on the bid shall result in Vendor's bid being disqualified. Vendors should include a contractor's license number in the space provided below.

Contractor's Name:

Contractor's License No.

The apparent successful Vendor must furnish a copy of its contractor's license prior to the issuance of a purchase order/contract.

2. **DRUG-FREE WORKPLACE:** W. Va. Code § 21-1D-5 provides that any solicitation for a public improvement contract requires each Vendor that submits a bid for the work to submit at the same time an affidavit that the Vendor has a written plan for a drug-free workplace policy. To comply with this law, Vendor must either complete the enclosed drug-free workplace affidavit and submit the same with its bid or complete a similar affidavit that fulfills all of the requirements of the applicable code. Failure to submit the signed and notarized drug-free workplace affidavit, or a similar affidavit that fully complies with the requirements of the applicable code, with the bid shall result in disqualification of Vendor's bid.
3. **AIA DOCUMENTS:** All construction contracts that will be completed in conjunction with architectural services procured under Chapter 5G of the West Virginia Code will be governed by the AIA A101-2007 and A201-2007 or the A107-2007 documents, as amended by the Supplementary Conditions for the State of West Virginia, in addition to the terms and conditions contained herein.
4. **SUBCONTRACTOR LIST SUBMISSION:** In accordance with W. Va. Code § 5-22-1, The apparent low bidder on a contract for the construction, alteration, decoration, painting or improvement of a new or existing building or structure valued at more than \$500,000.00 shall submit a list of all subcontractors who will perform more than \$25,000.00 of work on the project including labor and materials. This provision shall not apply to any other construction projects, such as highway, mine reclamation, water or sewer projects.

c. **Required Information.** The subcontractor list shall contain the following information:

- i. Bidder's name
  - ii. Name of each subcontractor
  - iii. License numbers as required by W. Va. Code § 21-11-1 et. seq.
  - iv. Notation that no subcontractors will be used if the bidder will perform the work
- d. **Submission.** The completed subcontractor list shall be provided to the Purchasing Division within one business day of the opening of bids for review. Failure to submit the subcontractor list within one business day after the deadline for submitting bids shall result in disqualification of the bid.
- e. **Substitution of Subcontractor.** Written approval must be obtained from the Purchasing Division before any subcontractor substitution is permitted. Substitutions are not permitted unless:
- i. The subcontractor listed in the original bid has filed for bankruptcy;
  - ii. The subcontractor in the original bid has been debarred or suspended; or
  - iii. The contractor certifies in writing that the subcontractor listed in the original bill fails, is unable, or refuses to perform his subcontract.
5. **GREEN BUILDINGS MINIMUM ENERGY STANDARDS:** In accordance with § 22-29-4, all new building construction projects of public agencies that have not entered the schematic design phase prior to July 1, 2012, or any building construction project receiving state grant funds and appropriations, including public schools, that have not entered the schematic design phase prior to July 1, 2012, shall be designed and constructed complying with the ICC International Energy Conservation Code, adopted by the State Fire Commission, and the ANSI/ASHRAE/IESNA Standard 90.1-2007: *Provided*, That if any construction project has a commitment of federal funds to pay for a portion of such project, this provision shall only apply to the extent such standards are consistent with the federal standards.

**REQUEST FOR QUOTATIONS #GSD136427**  
**Bldg 11 HVAC Annual Chiller and Tower Service**  
**Charleston, West Virginia**

Location: West Virginia State Office Building  
218 California Ave  
Charleston, West Virginia 25301

For: State of West Virginia  
General Services Division  
1900 Kanawha Blvd; East  
Charleston, West Virginia 25305

The Acquisition and Contract Administration Section of the Purchasing Division "State" for the West Virginia General Services Division is soliciting quotations to provide Annual Tower and Chiller Service as specified in the attached documents in Building 11 located at 218 California Ave. in Charleston, West Virginia. This document is intended to supplement information provided in the standard "Request for Quotation" and "General Terms and Conditions" issued by the Purchasing Division for this project. Vendors should carefully review all documents.

**Scope of Work:**

The work consists of providing annual maintenance and cleaning of the chillers and towers in Building 11 as specified by OEM service schedules (Attachments A and B) and manufacturer's recommendations. The Contractor shall also conduct testing to ensure the units are returned fully operational. There are 5 Trane Chillers and 5 Marley Towers.

<b><u>Chiller Serial Number</u></b>	<b><u>Model Number</u></b>
1. L99A00273	CVHF770
2. L99A00282	CVHF770
3. L99A00287	CVHF128
4. L99A00279	CVHF128
5. L99A00288	CVHF128

<b><u>Tower Serial Number</u></b>	<b><u>Model Number</u></b>
1. NCA 222 CS	137622-001-98
2. NCA 222 SC	137622-001-98

All work to be performed per manufacturer's specifications for annual service and maintenance. Following the cleanings and maintenance, the Contractor shall furnish a written report indicating all deficiencies found no longer than thirty (60) calendar days

after issuance of the Notice to Proceed. The overall costs for all labor, materials and associated costs to perform the cleanings and inspections (inclusive of the creation and submitting of the written deficiencies report) shall be the Base Bid.

Contractor shall furnish all materials, labor, and equipment necessary to complete all work as indicated by these specifications. The intent is that the completed work consists of the complete maintenance and cleaning of HVAC chillers and towers and units are brought back to full operation in Building 11. Contractor shall furnish any incidental work, materials, labor and equipment that are necessary to complete the work, even if such incidental work is not explicitly included in the contract documents

Any equipment or material contracted for prior to receipt of the signed purchase order and written Notice to Proceed letter shall be at the Bidder's risk.

**Documents:**

This Request for Quotations also incorporates the attached documents:

1. The WV Purchasing Division "Request for Quotation" and "General Terms and Conditions".
2. GSD136427 Attachment A: Trane Manual
3. GSD136427 Attachment B: Marley Manual
4. GSD136427 Attachment C: Bid Form

**Contract Period:**

The Contract shall be substantially completed within **Sixty (60)** calendar days from the issuance of the written Notice to Proceed.

**Reference Requirement:**

Bidders shall supply at least three references indicating their capabilities to perform such work (use Attachment C). References should include the name, location of the building in addition to the name, address and telephone number of a contact person with the building's owner familiar with the work.

**Qualifications:**

The Contractor shall have the minimum qualifications outlined below to perform the services specified under this Contract. The Contractor shall provide the Agency all documentation of the qualifications on line "A" prior to award (see Bid Form and Section labeled "Reference Requirement" above).

- A. The Contractor must provide references for at least three (3) distinct contracts documenting the successful completion of repair and warranty services of the type specified in the enclosed bid specifications.
- B. Work under this Contract may only be performed by a mechanic who has first provided documentation of certifications and or licensure for the following:

1. Electricians- WV Master Electricians License
2. Plumbers- WV Master Plumbers License
3. HVAC- EPA 608 Certification and Apprentice Certification or Completion of HVAC Vocational Program prior to January 1, 2006

**Definitions:**

- A. "Contractor" shall be defined as the successful bidder or vendor.
- B. "Agency Representative" shall be defined as the person designated by the Director of the General Services Division as having authority to act on behalf of the General Services Division.
- C. "Maintenance Service" shall be defined as the scheduled inspections and the replacement of parts, components, and materials on HVAC equipment prior to the failure or wear-out period of the parts, components or materials. The planned inspections and replacements shall be in accordance with the equipment manufacturer's specifications and recommendations.
- D. "Holidays" shall be defined as days designated by W.Va. Code §2-2-1 as legal holidays (i.e. new Year's Day, Martin Luther King's Birthday, President's Day, Memorial Day, West Virginia Day, Independence Day, Labor Day, Columbus Day, Veteran's Day, Thanksgiving Day, Lincoln's Day, Election Days, and Christmas Day).
- E. "Testing" shall be defined as a function test upon the completion of ordered services to ensure equipment is returned to normal operating mode or to determine if additional repairs are required.

**Payment:**

Invoices shall be submitted for payment (in arrears) and must include the following information:

1. Invoice must include invoice date, service dates, FEIN number, complete address of vendor and Master Contract number.
2. Invoices shall be mailed to the following address:

General Services Division  
1900 Kanawha Blvd. E.  
Building 1, Room MB-68  
Attn: Business Manager  
Charleston, WV 25305

All work shall be inspected and approved prior to payment.



**Supplementary General Conditions:**

A. The qualified Contractor shall satisfactorily perform all specified work outlined in the Scope of Work and further described in the drawings, specifications or other attachments. Authorization to perform the work described herein must be approved in writing by issuance of the Notice to Proceed and signed by the Agency Representative.

B. The Contractor shall procure all necessary permits and licenses to comply with all applicable laws, Federal, State, or municipal, along with all regulations, and ordinances of any regulating body.

**General Requirements:**

**Project Closeout:**

1. Final cleanup shall be completed prior to final acceptance.
2. Submit warranty documents to Agency Project Manager.
3. Perform final inspection with the Agency Project Manager.

**Final Inspection:**

The Final Inspection will be conducted by a Project Manager from the Agency. Work found to be in accordance with the Contract Documents will be accepted as complete for final acceptance. Unacceptable work, or work not in accordance with the Contract Documents shall be removed, replaced, changed or cleaned as required to meet requirements of Contract Documents prior to final acceptance. Final Acceptance does not waive or release Contractor to conform to the Contract Documents.

Final payment shall not be made until all work is finally accepted.

**Limits of Work:**

Work areas will be limited to those spaces required for access to the building.

Some interior space may be utilized for temporary (overnight) storage of equipment and tools. Coordinate storage needs with the Agency Project Manager.

Agency facilities shall remain in use during this contract. Contractor shall work with the Building Manager and Protective Services to coordinate the temporary access to work areas and otherwise provide for the Contractor needs to complete work. Contractor shall minimize disruption to building work areas and loading dock access.

**Use of Facilities:**

Contractor shall be permitted reasonable use of building utilities including power, water and sanitary sewage disposal as required for conducting the work. Contractor shall coordinate the location of service connections or use of receptacles with the Building Manager to avoid overloading existing circuits.

**Contractor Schedule:**

Work shall be conducted as a single project. Seventy-two (72) hours after award of the Contract, the Contractor shall submit a schedule showing the commencement and completion dates for each proposed area or subsystem. The schedule shall be reviewed and approved by the Agency Project Manager prior to commencement of the work. Where coordination or disruption of office workspaces or occupants may be required, provide at least one week's advance notice prior to conducting work in those areas. The Contractor shall coordinate the schedule around the Agency's work requirements.

**Waste Removal:**

The Contractor shall be required to leave the work area clean upon completion of work daily. Contractor shall make arrangements for the collection and disposal of Contractor's waste and construction related debris. Debris shall be removed on a daily basis.

**Contractor Visitor Badges:**

The Building 11 is a secure facility. Contractor shall provide a list of all personnel working on this project within the Building. This list shall include a copy of a valid driver's license or other legal identification and include date of birth and cell phone number. All proposed workers may be subjected to a criminal history / driver's license background check prior to being permitted to work in state buildings. Workers shall carry valid Contractor Photo ID Badges to be worn when working in the building. Under no circumstances shall a worker be assigned to this project without the validation first being submitted to the General Services Division and approval given.

**Work Restrictions:**

Work shall be generally performed inside the existing building during normal business working hours of 7:00 a.m. to 5:00 p.m., Monday through Friday, except state recognized holidays. Weekends may be permitted when pre-arranged with the Agency Project Manager.

Access to the building shall be coordinated with the Owner. Contractor shall not leave open doors unattended and shall close doors when not in use.

This is a non-smoking building. Smoking is not permitted within the building or near entrances, operable windows or outdoor air intakes.

**Parking:**

No parking is available on the project site. Parking in non-designated areas is not permitted. Parking is the responsibility of the contractor. With prior approval, contractor's vehicles may be brought on-site for loading & unloading or to provide equipment necessary for conducting the work.

Use of loading dock areas or sidewalk areas for parking is strictly prohibited.

**Codes:**

All work is to be performed in compliance with applicable Federal and State codes including but not limited to the International Building Code, International Mechanical Code, Life Safety Code, NEC, OSHA, UL, ANSI, ASME and related standards.

**Safety:**

All applicable local safety and OSHA rules and guidelines shall be met by the Contractor. Work shall be subject to verification and inspection by GSD Safety representatives. Such verification shall not relieve the Contractor from meeting all applicable safety regulations and inspection by other agencies.

Notify Owner if suspected hazardous materials are encountered. Any areas requiring abatement will be provided by the GSD under separate contract.

**Hot Work Permit:**

Contractor shall obtain Owner's permission prior to performing any work that requires an open flame, creates sparks, use's equipment that creates combustible temperatures, or performs any work that could result in a fire hazard. Owner will review work area and issue a 'Hot Work Permit' prior to Contractor commencing work. Note that the Contractor must take proper precautions and may be required to provide a Fire Watch as a condition of the permit.

**Workmanship:**

Contractor shall complete all work in a neat and workmanlike manner. All work shall be done using new materials in a manner that meets commercial quality standards. Work shall be neat, true, plumb and square, as applicable. Contractor shall verify all dimensions.

**Warranty:**

A one year warranty on labor and materials or the manufacturer's warranty, whichever is greater, are required.



## Periodic Maintenance

---

### Overview

This section describes the basic chiller preventive maintenance procedures, and recommends the intervals at which these procedures should be performed. Use of a periodic maintenance program is important to ensure the best possible performance and efficiency from a CenTraVac® chiller.

Recommended purge maintenance procedures for the Purifier Purge unit are covered by PRGD-SVU01A-EN or the latest revision which can be obtained at the nearest Trane office.

### Record Keeping Forms

An important aspect of the chiller maintenance program is the regular completion of records. Provided at the end of this manual are copies of the "Annual Inspection Check List and Report", "CenTraVac with UCP Commissioning Checklist and "Start-Up Test Log", a "Start-Up Test Log

for Water Cooled CenTraVacs with UCP Control Panels" and "UCP "Settings Group" Menu Record". When filled out accurately by the machine operator, the completed logs can be reviewed to identify any developing trends in the chiller's operating conditions.

For example, if the machine operator notices a gradual increase in condensing pressure during a month's time, he can systematically check, then correct the possible cause(s) of this condition (fouled condenser tubes, noncondensable in the system, etcetera)

### Daily Maintenance and Checks

[ ] Check the chiller's evaporator and condenser pressures, oil tank pressure, differential oil pressure and discharge oil pressure. Compare the readings with the values provided in the Normal Chiller Operating Characteristics table.

**IMPORTANT: IT IS HIGHLY RECOMMENDED THAT THE OPERATING LOG BE COMPLETED ON A DAILY BASIS.**

### CAUTION

#### Moisture Contamination!

**IF FREQUENT PURGING IS REQUIRED, MONITOR PURGE PUMPOUT RATE, IDENTIFY AND CORRECT SOURCE OF AIR OR WATER LEAK AS SOON AS POSSIBLE. Failure to do so can shorten chiller life expectancy, due to moisture contamination caused by leakage.**

[ ] Check the oil level in the chiller oil sump using the two sight glasses provided in the oil sump head. When the unit is operating, the oil level should be visible in the lower sight glass.



## Periodic Maintenance

### **⚠ WARNING**

#### **Hazardous Voltage w/ Capacitors!**

Disconnect all electric power, including remote disconnects before servicing. Follow proper lockout/tagout procedures to ensure the power cannot be inadvertently energized. For variable frequency drives or other energy storing components provided by Trane or others, refer to the appropriate manufacturer's literature for allowable waiting periods for discharge of capacitors. Verify with an appropriate voltmeter that all capacitors have discharged. Failure to disconnect power and discharge capacitors before servicing could result in death or serious injury.

Note: For additional information regarding the safe discharge of capacitors, see PROD-SVB06A-EN or PROD-SVB06A-FR

#### **Weekly Maintenance**

[ ] Complete all recommended daily maintenance procedures and checks. Complete logs on a daily basis.

#### **Every 3 Months**

[ ] Complete all recommended weekly maintenance procedures. Refer to the previous sections for details.

[ ] Clean all water strainers in the CenTraVac water piping system.

#### **Every 6 Months**

#### *Normal Chiller Operating Characteristics*

Operating Characteristic	Normal Reading
Approx. Evaporator Pressure	(6 to 9 PSIA) (-9 to -6 PSIG)
Approx. Condenser Pressure	(17 TO 27 PSIA) 2 to 12 PSIG (Standard Condensers)
Oil Sump Temperature:	
Unit Not Running	140°F to 145°F (60°C to 63°C)
Unit Running	80°F to 162°F (26.6°C to 72°C)
Differential Oil Pressure	18 to 22 psid

#### Notes:

1. Condenser pressure is dependent on condenser water temperature, and should equal the saturation pressure of HCFC-123 at a temperature above that of leaving condenser water at full load.
2. Normal pressure readings for ASME condensers exceed 12 PSIG.
3. Oil Tank Pressure 12" to 18" HG Discharge Oil Pressure 7 to 15 PSIG.



## Periodic Maintenance

---

Complete all recommended quarterly maintenance procedures.

Lubricate the vane control linkage bearings, ball joints, and pivot points; as needed a few drops of light machine oil (SAE-20) is sufficient.

Lubricate vane operator tang o-rings as described in the maintenance section.

Lubricate the oil filter shutoff valve o-rings by removing the pipe plug and adding several drops of Trane OIL00022. Replace plug.

Drain the contents of the rupture disc and purge discharge ventline drip-leg, into an evacuated waste container minimally and more often if the purge is operated excessively.

Also, apply one or two drops of oil on the vane operator shaft and

spread it into a very light film; this will protect the shaft from moisture and rust.

### Off-Season Maintenance

During those periods of time when the chiller is not operated, be sure the control panel is energized. This is to keep the purge operational, the oil heater warm and will also keep air out of the machine.

### Annual Maintenance

Shut down the chiller once each year to check the items listed; a more detailed inspection checklist is provided on the "Model CVHE, CVHF and CVHG CenTraVac Annual

Inspection Checklist and Report" illustrated in this manual.

Perform the annual maintenance procedures referred to in the Maintenance Section of the purge manual.

Use an ice water bath to verify that the accuracy of the evaporator refrigerant temperature sensor (4R10) is still within tolerance (+ or - 2.0° at 32°F (1° at 0°C)). If the evaporator refrigerant temperature displayed on the UCP's read-out is outside this 4-degree tolerance range, replace the sensor.

**Note:** If the sensor is exposed to temperature extremes outside its normal operating range (0°F to 90°F) (-18°C to 32°C), check its accuracy at six-month intervals.





## Oil Maintenance

---

### Compressor Oil Change on CVHE, CVHF, CVHG

Recommendations are to subscribe to an annual oil analysis program rather than automatically change the oil as part of scheduled maintenance. Change the oil only if indicated by the oil analysis. Use of an oil analysis program will reduce the chillers overall lifetime waste oil generation and minimize refrigerant emissions. The oil analysis should be performed by a qualified laboratory that is experienced in refrigerant and oil chemistry and in the servicing of Trane centrifugal chillers.

In conjunction with other diagnostics performed by a qualified service technician, oil analyses can provide valuable information on the performance of the chiller to help minimize operating and maintenance

costs and maximize its operating life. A drain fitting is installed in the oil filter top, after the oil filter, for obtaining oil samples.

**Note:** Use only Trane OIL00022. A full oil change is 9 gallons of OIL00022.

#### Oil Change Procedure

When oil analysis indicates the need to change compressor oil, use the following procedure for removing oil.

### CAUTION

#### Heater Damage!

**The oil sump heater must be deenergized before draining the sump. Failure to do so could possibly burn out the oil sump heater.**

[ ] Draw the oil from the chiller through the oil charging valve on the chiller oil sump into an approved, evacuated tank; or,

[ ] Pump the oil from the chiller through the oil charging valve into an airtight resealable container, using a magnetically-driven auxiliary pump.

Forcing the oil from the oil sump by pressurizing the chiller (by raising chiller temperature or adding nitrogen) is not recommended.

Refrigerant dissolved in the oil can be removed and returned to the chiller by using an appropriate deep-vacuum recovery unit and heating and agitating the oil container. Follow all Federal, State and Local regulations with regard to disposal of waste oil.



## Oil Maintenance

---

### Replacing Oil Filter

Replace oil filter: (1) annually, (2) at each oil change, (3) or if erratic oil pressure is experienced during chiller operation.

### Oil Filter Replacement

Use the following procedure to service the oil filter. Refer to Figure 34.

1. Run the oil pump for two to three minutes to insure that the oil filter is warmed up to the oil sump temperature.
2. Turn the oil pump motor off.
3. Pull the "D" handle on the rotary valve locking pin out of its detent and rotate the valve to the "DRAIN" position. An offset pointer is located on top of the valve with wrench flats to allow turning. The spring force on the locking pin should allow the pin to drop into a detent at this position.
4. Allow at least 15 minutes for the oil to drain from the filter back into the oil sump.
5. Pull the "D" handle to unlock the pin and rotate the valve to the "Change Filter" position. This isolates the filter from the unit. The locking pin should drop into a detent in this position.
6. Remove and replace the filter as quickly as possible. Tighten filter 2/3 to 3/4 turn per instructions written on the filter. Place the used filter in a reusable container. Follow all local, state and federal regulations to dispose of the filter. Pull the "D" handle to unlock the pin and rotate the valve to the "RUN" position. The locking pin should drop into a detent in this position. The chiller is now ready for operation.
7. Purge unit.
8. Check oil pressure 18-27 psi.



## Maintenance

### Other Maintenance Requirements

Compressors using new seal technology will not use O-rings. The O-ring has been replaced by Loctite 515 applied at a minimum film thickness of .010 applied across the width of the flange. The current jack bolt holes remain for disassembly.

### CAUTION

### Oil Supply System Problems!

Plugging of oil supply system could lead to bearing failure. Failure to use care could result in Loctite getting into the chiller which may cause problems with the Oil supply system and eductor system.

[ ] Inspect the condenser tubes for fouling; clean if necessary.

### WARNING

### Hazardous Voltage w/ Capacitors!

Disconnect all electric power, including remote disconnects before servicing. Follow proper lockout/tagout procedures to ensure the power cannot be inadvertently energized. For variable frequency drives or other energy storing components provided by Trane or others, refer to the appropriate manufacturer's literature for allowable waiting periods for discharge of capacitors. Verify with an appropriate voltmeter that all capacitors have discharged. Failure to disconnect power and discharge capacitors before servicing could result in death or serious injury. Note: For additional information regarding the safe discharge of capacitors, see PROD-SVB06A-EN or PROD-SVB06A-FR

[ ] Measure the compressor motor winding resistance to ground; a qualified service technician should conduct this check to ensure that the findings are properly interpreted.

Contact a qualified service organization to leak-test the chiller; this procedure is especially important if the system requires frequent purging.

[ ] Use a nondestructive tube test to inspect the condenser and evaporator tubes at 3-year intervals.

Note: It may be desirable to perform tube tests on these components at more frequent intervals, depending upon chiller application. This is especially true of critical process equipment.

[ ] Depending on chiller duty, contact a qualified service organization to determine when to conduct a complete examination of the unit to discern the condition of the compressor and internal components.

Note: (a) Chronic air leaks, which can cause acidic conditions in the compressor oil and result in premature bearing wear; and, (b) Evaporator or condenser water tube leaks. Water mixed with the compressor oil can result in bearing pitting, corrosion, or excessive wear.

[ ] Submit a sample of the compressor oil to a Trane qualified laboratory for comprehensive analysis on an annual basis; this analysis determines system moisture content, acid level and wear metal content of the oil, and can be used as a diagnostic tool.

### Lubrication

The only CVHE, CVHF and CVHG chiller component that requires periodic lubrication is the external vane linkage assembly and Rotary oil valve.

Lubricate the vane linkage shaft bearings and rod end bearings as needed with a few drops of light-weight machine oil.

The CenTraVac inlet guide vane tang operators should be serviced annually with R123 compatible grease. Use only Rheolube 734A, available from Trane as LUB00033 (16oz. standard grease gun cartridge) or LUB00063 (3oz. mini grease gun cartridge)

To service the 1st stage tang operator of all units except CVHF extended capacity chillers with 1470 or 1720 compressors,

1. The chiller must be off.
2. Carefully remove any insulation that may have been placed over the two lubrication ports of the tang operator base. This insulation will need to be replaced after the service is complete.
3. Note the position of the tang operator arm, note the placement of spacing washers etc., then disconnect the linkage rod from the tang operator arm. Manually move the tang operator arm and note the amount of effort required to operate the assembly.
4. Loosen but DO NOT REMOVE the 1/16" NPT lubrication port plug that is highest on the assembly.
5. Loosen and remove the remaining lower 1/16" NPT plug.
6. Using a grease gun with an appropriate fitting, insert ONLY Rheolube grease into the open port until clean grease is seen to appear around the threads of the plug in the opposite port.
7. Tighten the plug that was loosened in step 4. Tighten the plug to hand tight plus 1/4 to 1/2 turn.
8. Remove the grease fitting, if used.



## Maintenance

### DO NOT LEAVE GREASE FITTINGS INSTALLED.

If grease fittings have been used for this procedure then they **MUST BE REMOVED** before returning the unit to service. Grease fittings are not vacuum-tight and will become a leak path.

9. Using a clean wooden dowel or other similar tool, remove excess grease from the remaining open lubrication port.
10. Clean and then lightly coat the threads of the plug with Rheolube grease and re-install it into the lubrication port. Tighten the plug to hand tight plus 1/4 to 1/2 turn.
11. Before reconnecting the vane linkage, grasp the tang operator arm and manually operate the vane assembly. If it is now difficult to move, then the tang operator may have become "hydraulically locked" because of excess grease in the assembly. This situation could cause damage to the o-rings of the assembly. If this occurs then remove one of the lubrication plugs, remove some of the grease, then re-install the plug.
12. Reconnect the linkage to the tang operator arm. Ensure the spacer washers between the linkage and the arm are properly placed and that the assembly does not bind. Re-install any insulation that was cut or removed. The unit may be restarted.

To service the 1st and 2nd stage tang operators on CVHF and CDHF extended capacity chillers with 1470 or 1720 compressors.

The 1st and 2nd stage rotary inlet guide vane tang operators of the extended capacity chillers also require periodic lubrication, at least annually, with R123 compatible Rheolube grease. These actuators have two 1/8" NPT plugs located 180 degrees apart, with one on the top

and the other on the bottom of the operator base. Use the same procedure as described above, except that it will be necessary to temporarily disconnect the vane actuators from the tang operator arms in order to test for a "hydraulically locked" condition.

The oil valve block rotary valve uses dual O-Rings to seal to atmosphere. These should be manually lubricated by removing the pipe plug at the valve lubrication port and placing a few drops of Trane OIL00022 in the cavity. Be sure to reinstall the pipe plug when lubrication is completed.

Figure 33. Rotary valve in drain position

**NOTE: ROTARY VALVE SHOWN IN DRAIN POSITION.**

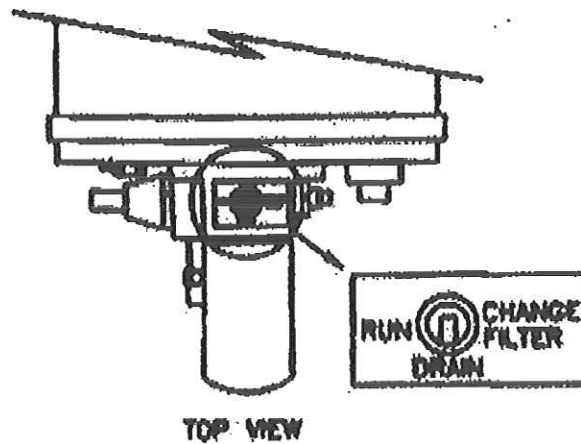

Front View with Refrigerant Pump

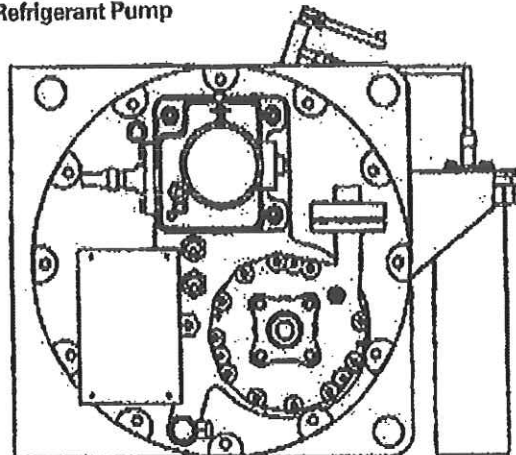



## Maintenance

---

### Refrigerant Charge

#### **⚠ WARNING**

#### **Contains Refrigerant!**

System contains oil and refrigerant and may be under positive pressure. Recover refrigerant to relieve pressure before opening the system. See unit nameplate for refrigerant type. Do not use non-approved refrigerants, refrigerant substitutes, or refrigerant additives.

Failure to follow proper procedures or the use of non-approved refrigerants, refrigerant substitutes, or refrigerant additives could result in death or serious injury or equipment damage.

The refrigerant charging procedure for Trane centrifugal chillers is:

1. If water is present in the tubes, break machine vacuum with refrigerant vapor, or circulate water, to avoid tube damage.
2. Always use refrigerant compatible hoses or copper-tubing with self-sealing connections or shut-off valves.

3. Transfer the refrigerant using one of the following (listed in order of preference):
  - a. An approved Trane low-pressure refrigerant recovery and recycle unit.
  - b. The available pressure differential.
  - c. Gravity. (Use a return vent line to refrigerant drums to equalize pressure.)
5. Do not use dry nitrogen to push refrigerant into the chiller as was common practice in the past. This will contaminate the charge and require excessive purging, which will result in unnecessary release of refrigerant.
6. Weigh in the proper charge.
7. Use recovery and recycle unit or vacuum pump to evacuate hoses; discharge outdoors.
8. If refrigerant is supplied in new returnable cylinders, be sure and refer to General Service Bulletin CVHE-SB-48B for information on returning cylinders. This service bulletin is available at the nearest Trane office.

Depending on the chiller duty, contact a qualified service organization to determine when to conduct a complete examination of the unit to discern the condition of the compressor and internal components.

**Note:** If your chiller is covered by a Trane extended warranty, the terms of that warranty may require that the procedures listed in the Periodic Maintenance section of this manual be followed for your extended warranty to remain in force. The terms may also require that the chiller be inspected by a Trane authorized warranty agent every 4-years or 40,000 operating hours, whichever occurs first. This inspection will include, at a minimum, a review of the annual inspection checklists and the daily operating logs, as well as performance of a leak test and a general inspection of the chiller. The owner is then required to follow the recommendations made as a result of this inspection at the owners expense.



## Maintenance

### Recovery and Recycle Connections

To facilitate refrigerant removal and replacement, newer-design CVHE, CVHF and CVHG units are provided with a 3/4-inch vapor fitting with shutoff valve on the chiller suction and with a 3/4-inch liquid connection with shutoff valve at the bottom of the evaporator shell. (Refer to Refrigerant Handling Guidelines.)

### Leak Testing

To leak-test a chiller containing full refrigerant charge, raise chiller pressure using a controlled hot water or electric-resistance system to a maximum of 8 psig. Do not use nitrogen, which will cause excessive refrigerant discharge by the purge system.

### Cleaning the Condenser

#### CAUTION

#### Proper Water Treatment!

The use of untreated or improperly treated water in a CenTraVac may result in scaling, erosion, corrosion, algae or slime. It is recommended that the services of a qualified water treatment specialist be engaged to determine what water treatment, if any, is required. Trane assumes no responsibility for equipment failures which result from untreated or improperly treated water, or saline or brackish water.

See Figure 34 which shows a Typical Chemical Cleaning Setup.

Figure 34 - Typical Chemical Cleaning Setup

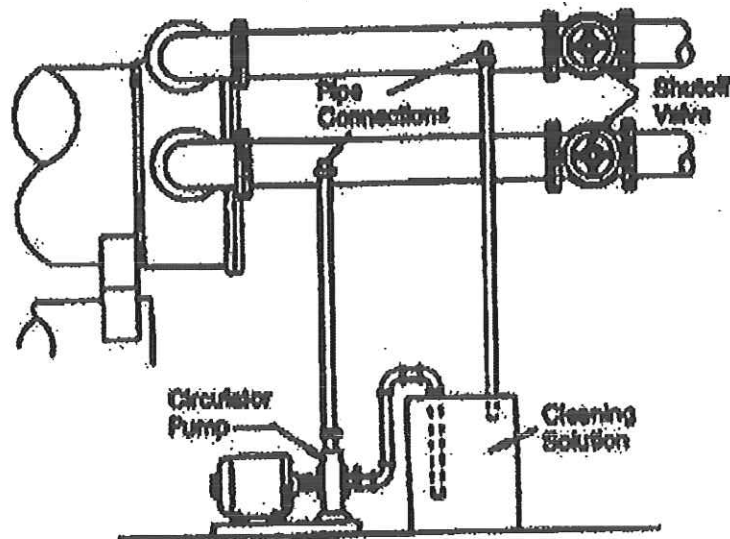





## Maintenance

---

Condenser tube fouling is indicated when the approach temperature (the difference between the condensing refrigerant temperature and the leaving condenser water temperature) is higher than predicted.

If the annual condenser tube inspection indicates that the tubes are fouled, two cleaning methods, mechanical and chemical, can be used to rid the tubes of contaminants.

Use the mechanical cleaning method to remove sludge and loose material from smooth-bore tubes.

To clean other types of tubes including internally-enhanced types, consult a qualified service organization for recommendations.

1. Remove the retaining nuts and bolts from the water box covers at each end of the condenser. Use a hoist to lift the covers off the water box. (A threaded connection is provided on each water box cover to allow insertion of an eyebolt).
2. Work a round nylon or brass bristled brush (attached to a rod) in and out of each of the condenser water tubes to loosen the sludge.
3. Thoroughly flush the condenser water tubes with clean water.

Scale deposits may be best removed by chemical means. Be sure to consult a qualified chemical house in the area (one familiar with the local water supply's chemical mineral content) for a recommended cleaning solution suitable for the job. Remember, a standard condenser water circuit is composed solely of copper, cast iron and steel.

### CAUTION

#### Unit Corrosion Damage!

Proper procedures must be followed when using corrosive chemicals to clean water side of unit. It is recommended that the services of a qualified chemical cleaning firm be used. Proper personal protective equipment as recommended by the chemical manufacturer should be used. Refer to the chemicals MSDS sheet for proper safety procedures. Failure to follow proper procedures could result in corrosion damage to the unit and tubes.

**IMPORTANT: ALL OF THE MATERIALS USED IN THE EXTERNAL CIRCULATION SYSTEM, THE QUANTITY OF THE SOLUTION, THE DURATION OF THE CLEANING PERIOD, AND ANY REQUIRED SAFETY PRECAUTIONS SHOULD BE APPROVED BY THE COMPANY FURNISHING THE MATERIALS OR PERFORMING THE CLEANING.**

**REMEMBER, HOWEVER, THAT WHENEVER THE CHEMICAL TUBE CLEANING METHOD IS USED, IT MUST BE FOLLOWED UP WITH MECHANICAL TUBE CLEANING, FLUSHING AND INSPECTION.**

#### Cleaning the Evaporator

Since the evaporator is typically part of a closed circuit, it does not accumulate appreciable amounts of scale or sludge. Normally, cleaning every 3 years is sufficient. However, on open CVHE, CVHF and CVHG systems, such as air washers, periodic inspection and cleaning is recommended.

#### Control Settings and Adjustments

Time delays and safety control cutout settings need to be checked annually. For control calibration and check-out, contact a Trane qualified service organization.



## Maintenance

### Purge System

Because some sections of the chiller's refrigeration system operate at less-than-atmospheric pressure, the possibility exists that air and moisture may leak into the system. If allowed to accumulate, these noncondensables become trapped in the condenser; this increases condensing pressure and compressor power requirements, and reduces the chiller's efficiency and cooling capacity.

The Trane EarthWise Purge is the only purge system available for the CVHE, CVHF and CVHG chiller. The purge is designed to remove noncondensable gases and water from the refrigeration system. EarthWise Purge unit operation, maintenance and trouble shooting is covered by a separate operation and maintenance manual, which may be obtained from the nearest Trane office.

### Overview

This section describes extended storage requirements for UCP installed CVHE, CVHF and CVHG chillers to be removed from service for an undetermined length of time.

### Unit Preparation

The following steps are necessary in order to properly prepare a unit for storage.

1. Remove all liquid refrigerant if the unit is charged.

### **⚠ WARNING**

#### Contains Refrigerant!

**System contains oil and refrigerant and may be under positive pressure. Recover refrigerant to relieve pressure before opening the system. See unit nameplate for refrigerant type. Do not use non-approved refrigerants, refrigerant substitutes, or refrigerant additives.**

**Failure to follow proper procedures or the use of non-approved refrigerants, refrigerant substitutes, or refrigerant additives could result in death or serious injury or equipment damage.**

2. After the liquid refrigerant is removed, using a recovery or recycle unit or vacuum pump, pull a vacuum to remove remaining refrigerant vapor from the unit.

3. After all traces of refrigerant are out of the unit, a positive nitrogen charge should be put into the unit (6 to 8 psig). This positive pressure must be checked monthly to insure no noncondensables get into the unit. Use a pressure gage on the evaporator shell to verify that the 6 to 8 psig dry nitrogen holding charge is still in the chiller. If this charge has escaped, contact a qualified service organization and the Trane sales engineer that handled the order.
4. The refrigerant charge should be stored in proper refrigerant containers. Due to possible leakage, do not store in used drums.
5. Maintain control power to the control panel. This will maintain oil temperature in the oil sump and the capability of the control panel to present report information. The Chiller Reports should be viewed once a week for normal readings. Any abnormal observation must be reported to the Trane Sales Engineer that handled the order.



## Maintenance

---

### **⚠ WARNING**

#### **Hazardous Voltage w/ Capacitors!**

Disconnect all electric power, including remote disconnects before servicing. Follow proper lockout/tagout procedures to ensure the power cannot be inadvertently energized. For variable frequency drives or other energy storing components provided by Trane or others, refer to the appropriate manufacturer's literature for allowable waiting periods for discharge of capacitors. Verify with an appropriate voltmeter that all capacitors have discharged. Failure to disconnect power and discharge capacitors before servicing could result in death or serious injury.

**Note:** For additional information regarding the safe discharge of capacitors, see PROD-SVB06A-EN or PROD-SVB06A-FR

6. Remove the factory installed jumper or the field installed wiring on terminals in the unit control panel. This will prevent unwanted chiller operation.
7. Set the purge operating mode to OFF on UCP chillers.

8. The oil can be left in the unit.
9. The water side should not cause a problem if shut down and drained. There may be slight scaling inside the tubes, but not enough to cause a problem. The customer should inspect and clean tubes before the unit is returned to service.

**IMPORTANT: DO NOT USE UNTREATED OR IMPROPERLY TREATED WATER, OR EQUIPMENT DAMAGE MAY OCCUR.**

**IMPORTANT: SCALE DEPOSITS ARE BEST REMOVED BY CHEMICAL MEANS. BE SURE TO CONSULT ANY QUALIFIED CHEMICAL HOUSE IN THE AREA (ONE FAMILIAR WITH THE LOCAL WATER SUPPLY'S CHEMICAL MINERAL CONTENT) FOR A RECOMMENDED CLEANING SOLUTION SUITABLE FOR THE JOB.**

10. Motor bearings: If the motor sits for a long time the bearings could take a set and cause bearing problems or replacement later. Once every six months the chiller oil pump must be started and the compressor motor bump started to rotate the shaft. Contact

a qualified service organization to perform this task. If the compressor motor cannot be bump started, then the shaft must be rotated manually by a qualified service organization.

11. Obtain an oil analysis initially after six months of storage, and once each succeeding year. If no oil breakdown is evident do not change the oil. If breakdown is evident, the oil must be replaced.
12. If the unit is stored for more than five years, and the storage is expected to be indefinite, the unit should be examined for leaks every five years from the initial storage date.
13. When the unit is to be returned to service, the services of a qualified service organization should be obtained to conduct all activities associated with the startup of a new chiller.



**GenTraVac®  
Annual Inspection Check List and Report:**

**Compressor Motor**

- Motor Continuity check  
Good  Open
- Check and tighten motor terminals
- Meg Motor  
Phase 1  Phase 2  Phase 3
- Check nameplate rating  
Amps

**Starter**

- Check condition of starter contacts  
Good  Fair  Replace
- Check, tighten if necessary all connections  
per manufactures specs

**Oil Sump**

- Change oil  
If oil analysis, refer to program procedure
- Gallons (9) required
- Refrigerant/Oil pump motor ground check  
Good  Open
- Check motor terminal
- Change oil filter

**Condenser**

- Visually inspect for scaling in tubes;  
not findings and make recommendations

**Control Circuits**

- Low refrigerant temperature sensor check  
\_\_\_°F set point \_\_\_°F trip point (ice water)
- Leaving Evaporator water temperature  
sensor check-out  
\_\_\_°F set point \_\_\_°F trip point (ice water)
- Condenser High Pressure Switch check-out  
\_\_\_psig set point  
\_\_\_psig trip point
- Check Net Oil Pressure
- Check adjustment and operation of inlet  
guide vane actuator stepper motor  
(Note: each machine is unique and must have  
the full open position number of steps input.)

**Leak Test Chiller**

- Refrigerant and oil analysis for acid content
- Sample refrigerant and oil for laboratory  
analysis (attach a copy of analysis to next  
monthly inspection report)

**Purge Unit**

- Review the purge operation maintenance  
manual and follow maintenance and/or  
inspection items identified.

Comments:

---



---



---



---

Recommendations:

---



---



---



---



---

# User Manual



---

## Contents

---

### △ Note

*This manual contains vital information for the proper installation and operation of your cooling tower. Carefully read the manual before installation or operation of the tower and follow all instructions. Save this manual for future reference.*

Tower Location .....	4
Tower Shipment.....	5
Receiving Tower .....	5
Hoisting Tower .....	5
Tower Installation .....	6
Tower Start-Up.....	9
Tower Operation .....	13
Wintertime Operation .....	15
Water Treatment and Blowdown .....	18
Cooling Tower Cleaning .....	19
Schedule of Tower Maintenance .....	22
Motor Relubrication Instructions .....	24
Seasonal Shutdown Instructions .....	25
Prolonged Shutdown .....	26
Marley Services .....	26
Additional Information .....	27
Troubleshooting .....	28
Maintenance Schedule .....	30

The following defined terms are used throughout this manual to bring attention to the presence of hazards of various risk levels, or to important information concerning the life of the product.

---

### △ Warning

*Indicates presence of a hazard which can cause severe personal injury, death or substantial property damage if ignored.*

---

### △ Caution

*Indicates presence of a hazard which will or can cause personal injury or property damage if ignored.*

---

### △ Note

*Indicates special instructions on installation, operation or maintenance which are important but not related to personal injury hazards.*



---

## Preparation

The Marley NC cooling tower purchased for this installation represents the current state of the art in crossflow, induced draft cooling tower design. Thermally and operationally, it is the most efficient cooling tower of its class.

These instructions—as well as those offered separately on motors, fans, Geareducer®, couplings, drive shafts, fan shafts, float valves, etc.—are intended to assure that the tower serves you properly for the maximum possible time. Since product warrantability may well depend upon your actions, please read these instructions thoroughly prior to operation.

If you have questions about the operation and/or maintenance of this tower, and you don't find the answers in this manual, please contact your Marley sales representative. *When writing for information, or when ordering parts, please mention tower serial number shown on the nameplate located on the access door.*

---

## Safety First

The location and orientation of the cooling tower can affect the safety of those responsible for installing, operating or maintaining the tower. However, since Marley does not determine the location or orientation of the tower, we cannot be responsible for addressing those safety issues that are affected by the tower's location or orientation.

---

### △ Warning

*The following safety issues should be considered by those responsible for designing the tower installation.*

- *access to hot water basins*
- *access to and from maintenance access doors*
- *the possible need for ladders (either portable or permanent) to gain access to the hot water basins or maintenance access doors*
- *the possible need for external access platforms*
- *potential access problems due to obstructions surrounding the tower*
- *lockout of mechanical equipment*
- *the possible need for safety cages around ladders*
- *the need to avoid exposing maintenance personnel to the potentially unsafe environment inside the tower.*

---

## Preparation

*Those are only some of the safety issues that may arise in the design process. Marley strongly recommends that you consult a safety engineer to be sure that all safety considerations have been addressed.*

Several options are available that may assist you in addressing some of these personnel safety concerns, including:

- distribution basin access platforms with ladder and handrail
- ladder extensions (used where the base of the tower is elevated)
- safety cages for fan deck ladders
- external tube lines
- fan cylinder extensions
- access door platform
- motor located outside the tower
- external motor access platform

---

## Tower Location

Space available around the tower should be as generous as possible to promote ease of maintenance—and to permit freedom of airflow into and through the tower. If you have questions about the adequacy of the available space and the intended configuration of the tower, please contact your Marley sales representative for guidance.

Prepare a stable, *level* support foundation for the tower, utilizing weight, wind load, and dimensional information appearing on appropriate Marley submittal drawings. *Supports must be level to insure proper operation of the tower.*

---

### △ Warning

*The cooling tower must be located at such distance and direction to avoid the possibility of contaminated tower discharge air being drawn into building fresh air intake ducts. The purchaser should obtain the services of a Licensed Professional Engineer or Registered Architect to certify that the location of the tower is in compliance with applicable air pollution, fire, and clean air codes.*

---

## Receiving and Hoisting

---

### Tower Shipment

Unless otherwise specified, NC towers ship by truck (on flat bed trailers), which lets you receive, hoist, and install the tower in one continuous operation. Most single-cell towers ship on one truck. Large modular towers may ship one cell on two trucks. Multicell towers, depending on their size, may require more than one truck.

Responsibility for the condition of the tower upon its arrival belongs to the trucker—as does the coordination of multiple shipments, if required.

---

### Receiving Tower

Prior to unloading the tower from the delivering carrier, inspect the shipment for evidence of damage in transit. If damage is apparent, note the freight bill accordingly. This will support your future recovery claim.

Find and remove the installation instruction drawings and bills of material located in a plastic bag in the cold water basin. This information should be kept for future reference and maintenance purposes.

---

### Hoisting Tower

NC80110, NC80111, and NC80112 models consist of two modules per cell. The upper module includes hoisting clips at the bottom of the module. The hoisting clips on the lower module are also located near the bottom on the sides of the cold water basin. All other models ship in a single module and include hoisting clips located near the bottom of the tower on the cold water basin sides. A **Hoisting-Installation** label which has hoisting dimensional information is located on the side casing near the tower centerline. Remove tower from the carrier and hoist into place according to the instructions on the label.

---

#### △ Warning

***Hoisting clips are provided for ease of unloading and positioning tower. For overhead lifts or where additional safety is required, safety slings should also be placed under the tower. Under no circumstances should you combine the top and bottom modules of modular models and attempt to hoist them at the same time by utilizing the hoisting clips alone!***

---

## Installation

---

### Tower Installation

---

△ Note

*These installation instructions are intended to help you prepare before your tower arrives. If discrepancies exist between these instructions and those shipped with the tower, the instructions shipped with the tower will govern.*

1. Prior to placement of the tower, confirm that the supporting platform is level, and that the anchor bolt holes are correctly located in accordance with Marley drawings.
2. Place tower (or bottom module of NC80110, NC0111 and NC50112 models) on your prepared supports, aligning anchor bolt holes with those in your supporting steel. Make sure that the orientation agrees with your intended piping arrangement. Attach tower to supporting steel with four 3/4" (19 mm) diameter bolts and flat washers (by others).
3. **NC80110, NC80111, and NC80112 models only.** Before setting top module in place on bottom module, clean any debris from the underside of the top module fill, skid and beams and from the top of the bottom module and remove shipping cover from bottom of top module—replace fasteners at side of module to prevent leaks. Place top module on the top peripheral bearing surface (factory-installed gasket) of bottom module, aligning mating holes as it is set in place. Make sure that the orientation of the top module agrees with your intended piping arrangement. Sections are 180° reversible with respect to each other. Attach top module to bottom module with fasteners provided, according to **"NC Field Installation Manual" Assembly Instructions.**

*If tower purchased is one fan cell only, ignore steps 4 through 8.*

4. If collection basins are to be equalized by the use of Marley standard flumes, unbolt the coverplate from the basin of the cell just installed. The coverplate is located in the center of the basin side.
5. Unbolt temporary coverplate from the basin of the second cell and set second cell (or bottom module of second cell) in place. Align anchor bolt holes and flume openings in basin sides.
6. Install flume according to *Field Installation Manual* instructions.

---

△ Note

*It is important that the cells be firmly anchored before the flume is attached to the second cell.*

---

## Installation

7. Repeat steps 2 and 3 for second top section on NC80110, NC80111, and NC80112 models.
8. Repeat steps 4 through 7 for any remaining cells.
9. Attach your cold water supply piping to the cold water basin outlet connection in accordance with drawing instructions, and utilizing gaskets provided by Marley.

---

### △ Caution

***Do not support your pipe from the tower or outlet connection—support it externally.***

Normally, one of the following three outlet arrangements is provided:

**Side suction connection:** This is a factory-installed, galvanized pipe nipple, extending horizontally from the side of the cold water basin. It is both beveled for welding—and grooved for a mechanical coupling. If a weld connection is used, it is recommended that the weld area be protected against corrosion. Cold galvanizing is suggested, applied according to the manufacturer's instructions.

**Bottom outlet connection:** This is a factory-installed, circular opening in the cold water basin floor of one or more cells. An appropriately-sized circular opening has been drilled to accept a 125# ANSI B16.1 flat-face flange connection.

**Side outlet sump connection:** Unless otherwise specified, sumps are manufactured of galvanized or stainless steel construction. Because of their size, they are attached upside down in the basin to prevent damage in shipment. They must be inserted into the square opening prepared in the floor of the cold water basin of one or more cells—sealed against leakage, and attached by machine bolts, according to the installation drawing included. An appropriately-sized circular opening in the vertical face of the sump has been drilled to accept a 125# ANSI B16.1 flat-face flange connection.

10. Attach makeup water supply piping to appropriately-sized float valve connection located in cold water basin side wall. Install the drain and overflow according to the "NC Field Installation Manual" *Assembly Instructions*. If you wish to pipe overflow and drain water to a remote discharge point, make those connections at this time also.
11. Install your warm water piping at the inlet location on the tower.

---

## Installation

---

### △ Note

*Fasteners and components provided by others that are to be attached to the tower must be compatible with the cooling tower materials—i.e. fasteners in a stainless steel cold water basin must be stainless steel.*

---

### △ Caution

*Except for the horizontal components of top-mounted piping, and as prescribed on Marley drawings, do not support your pipe from the tower or inlet connection—support it externally.*

Normally, one of the following inlet arrangements is provided:

**Standard distribution basin connections:** These are circular hot-water inlet openings in the top deck of the tower. On NC80101, NC80103 and NC80104 models a single location is located near the centerline of the tower near the casing side. All other models have two inlet locations on the casing side. Piping inserts vertically into the opening.

**Bottom inlet connection (option):** An appropriately sized hole and bolt circle—one per cell—is provided in the floor of the cold water basin. Bolt circle is designed to accept a standard 125# flat-face flange.

12. Wire motor in accordance with wiring diagram.

13. Install distribution basin access port covers.

---

### △ Warning

*For maintenance/safety purposes, Marley recommends a lockout type disconnect switch for all mechanical equipment. In addition to a disconnect switch, the motor should be wired to main power supply through short circuit protection, and a magnetic starter with overload protection.*



---

## Operation

---

---

### △ Warning

***Among other sources, outbreaks of Legionnaires' Disease have reportedly been traced to cooling towers. Maintenance and water treatment procedures that prevent amplification and dissemination of Legionella and other airborne bacteria should be formulated and implemented BEFORE systems are operated and continued regularly thereafter to avoid the risk of sickness or death.***

### Water System:

1. New installations should be cleaned and treated with biocides by a water treatment expert before startup.
2. Remove any and all accumulated debris from tower. Pay particular attention to inside areas of cold water basin, hot water basins, louvers and drift eliminators. Make sure that cold water suction screens are clear and properly installed.
3. For models NC80101, NC80102 and NC80103, fill the water system to an approximate depth of 7" (178 mm) in the depressed area of the cold water basin at the center of the tower. For all other models, fill the water system to an approximate depth of 8" (203 mm). This is the recommended operating water level. Adjust the float valve so that it is 75% open at that level. Continue filling the system until the water reaches a level approximately 1/8" (3 mm) below the lip of the overflow.

---

### △ Note

***If tower is equipped with a standard side-suction connection, vent accumulated air from the top of the suction hood by removing one or both tap screws provided at that location. Replace these tap screws when venting is complete. (On certain models, the top of the suction hood for 14" (356 mm) diameter side suction is 1 1/4" (32 mm) above the top of the overflow. In those situations, it is necessary to block the overflow and continue filling the basin to the level where the aforementioned tap screws are submerged before venting.)***

4. Start pump(s) and observe system operation. Since the water system external to the tower will have been filled only to the level achieved in the cold water basin, a certain amount of "pump-down" of the basin water level will occur before water completes the circuit and begins to

---

## Operation

fall from the fill. The amount of initial pump-down may be insufficient to cause the float valve to open. However, you can check its operation by pressing down on the operating lever to which the stem of the float valve is attached.

Some trial and error adjustment of the float valve may be required to balance the makeup water with tower operation. Ideally, the float valve setting will be such that no water is wasted through the overflow at pump shutdown. However, the water level after pump start-up must be deep enough to assure positive pump suction.

5. Check the water level with the UniBasin top deck. Uniform distribution basin depth of 3" to 5 1/2" (76 mm to 140 mm) is essential to efficient tower operation. Contact your Marley sales engineer if you are considering a permanent change in circulating water flow rate that would prevent operation within these limits.
6. Continue pump operation for about 15 minutes, after which it is recommended that the water system be drained, flushed, and refilled.
7. While operating the condensing water pump(s) and prior to operating the cooling tower fan, execute one of the two alternative biocidal treatment programs described in the following:
  - Resume treatment with the biocide which had been used prior to shutdown. Utilize the services of the water treatment supplier. Maintain the maximum recommended biocide residual (for the specific biocide) for a sufficient period of time (residual and time will vary with the biocide) to bring the system under good biological control
  - or*
  - Treat the system with sodium hypochlorite to a level of 4 to 5 mg/L (ppm) free chlorine residual at a pH of 7.0 to 7.6. The chlorine residual must be held at 4 to 5 mg/L (ppm) for six hours, measurable with standard commercial water test kits.

If the cooling tower has been in operation and then shut down for a duration of time and not drained, perform one of the two previous biocidal treatment programs directly to the cooling water storage vessel (cooling tower sump, drain down tank, etc.) without circulating stagnant water over the cooling tower fill or operating the cooling tower fan.

After biocidal pretreatment has been successfully completed, cooling water may be circulated over the tower fill with the fan off.



---

## Operation

When biocidal treatment has been maintained at a satisfactory level for at least six hours, the fan may be turned on and the system returned to service. Resume the standard water treatment program, including biocidal treatment.

### Mechanical Equipment:

---

#### △ Warning

***Always shut off electrical power to the tower fan motor prior to performing any maintenance on the tower. Any electrical switches should be locked out and tagged out to prevent others from turning the power back on.***

1. If equipped, check oil level in accordance with the *Geareducer User Manual* for the Geareducer. (Although the Geareducer was filled to the proper level at the factory, tipping during shipment and hoisting may have caused some loss of oil.) If oil is required, fill Geareducer to the proper level with approved lubricant. (See *Geareducer User Manual*) Check oil level at the Geareducer or dipstick (standpipe located on fan deck, if so equipped) to confirm that the proper level is indicated.
2. Install top fan ring and fan guard according to the installation drawing shipped with the tower. NC80101 and NC80102 models include a single-piece fan guard. All other models include a two-piece fan guard. Models with extended velocity-recovery cylinders do not have fan guards.

---

#### △ Warning

***Improper installation of the fan cylinder and fan guard will destroy the structural integrity of the fan guard. Failure of the fan guard could allow operating or maintenance personnel to fall into the rotating fan.***

3. Spin the fan manually to assure that all fan blades properly clear the inside of the fan cylinder. If equipped observe the action of the coupling (or drive shaft couplings) to be sure that the motor and Geareducer are properly aligned. If necessary, correct the alignment in accordance with the included manual.

For Power Belt Drive equipped models observe the action of the sheaves and belts to be sure that the motor is properly aligned with the fan sheave. See Belt Tensioning and Sheave Alignment on page 20.

---

## Operation

---

### △ Caution

*It is essential that the fan cylinder and fan guard be installed in accordance with the Field Installation Manual shipped with the tower. Do not force the fan cylinder out of round.*

4. Momentarily bump (energize) the motor and observe rotation of the fan. The fan should rotate in a counterclockwise direction when viewed from below. If rotation is backwards, shut off the fan and reverse two of the three primary leads supplying power to the motor.

---

### △ Caution

*If tower is equipped with a two-speed motor, check for proper rotation at both speeds. Check also to see that starter is equipped with a 20 second time delay which prevents direct switching from high speed to low speed. If the fan is intended to be reversed for deicing purposes, make sure that the starter is equipped with a 2 minute time delay between changes of direction. These delays will prevent abnormal stress from being applied to the mechanical equipment and the electrical circuit components.*

5. Run the motor and observe the operation of the mechanical equipment. Operation should be stable, and if equipped, there should be no evidence of oil leakage from the Geareducer or oil lines.
6. If equipped with belt drive check the torque on the fan and motor sheave after 10 to 60 hours of operation. See Bushing Fastener Torque Values on page 21.

---

### △ Note

*If the water supply system is not being operated—or if there is no heat load on the system—motor amps read at this time may indicate an apparent overload of as much as 10–20%. This is because of the increased density of unheated air flowing through the fan. Determination of an accurate motor load should await the application of the design heat load.*

---

## Operation

---

### Tower Operation

#### General:

The cold water temperature obtained from an operating cooling tower will vary with the following influences:

1. **Heat load:** With the fan in full operation, if the heat load increases, the cold water temperature will rise. If the heat load reduces, the cold water temperature will reduce.

Note that the number of degrees ("range") through which the tower cools the water is established by the system heat load and the amount of water being circulated, in accordance with the following formula:

$$\text{Range, } ^\circ\text{F} = \frac{\text{Heat Load (Btu/hr)}}{\text{GPM} \times 500}$$

or — in SI units

$$\text{Range} - ^\circ\text{C} = \frac{\text{Heat Load (kilowatts)}}{\text{Liters/sec} \times 4.187}$$

The cooling tower establishes *only* the cold water temperature attainable under any operating circumstance.

2. **Air wet-bulb temperature:** Cold water temperature will also vary with the wet-bulb temperature of the air entering the louvered faces of the tower. Reduced wet-bulb temperatures will result in colder water temperatures. However, the cold water temperature will not vary to the same extent as the wet-bulb. For example, a 20°F (11 °C) reduction in wet-bulb may result in only a 15°F (8°C) reduction in cold water temperature.
3. **Water flow rate:** Increasing the water flow rate (GPM or L/s) will cause a slight elevation in cold water temperature, while reducing the water flow rate will cause the cold water temperature to decrease slightly. However, at a given heat load (see formula above), water flow reductions *also* cause an increase in the incoming hot water temperature. Use care to prevent the hot water from exceeding 125°F, (52°C) in order to prevent damage to the tower components.

---

## Operation

4. **Air flow rate:** Reducing air flow through the tower causes the cold water temperature to rise. *This is the approved method by which to control leaving water temperature.*

If your tower is equipped with a single-speed motor, the motor may be shut off when the water temperature becomes too cold. This will cause the water temperature to rise. When the water temperature then becomes too warm for your process, the motor can be restarted.

---

### △ Caution

*When operating in this mode care must be taken not to exceed a total acceleration time of 30 seconds per hour.*

**Fan cycling limits:** From a dead stop, determine the number of seconds it takes the fan to arrive at full speed. Divide this number into 30 to determine the allowable number of starts per hour. Considering the normal fan and motor sizes utilized on NC Class towers, anticipate that approximately 4 to 5 starts per hour are allowable.

If your tower is equipped with a two-speed motor, you will enjoy greater opportunity for temperature control. When the water temperature becomes too cold, switching the fan to half-speed will cause the cold water temperature to rise—*stabilizing* at a temperature a few degrees higher than before. With a further reduction in water temperature, the fan may be cycled alternately from half-speed to off—subject to the same constraint of *30 seconds of allowable acceleration time per hour* as outlined above.

If your tower consists of two or more cells, cycling of motors may be shared between cells, increasing your steps of operation accordingly.

Multicell towers equipped with two-speed motors will maximize energy savings and minimize sound levels if fans are staged so that all fans are brought up to low speed before any fan goes to high speed.

For greater insight on cold water temperature control, please read "Cooling Tower Energy and its Management", *Technical Report #H-001-A*, available from your Marley sales representative.



---

## Operation

---

### Wintertime Operation:

The Marley fill system used in NC cooling towers has air entrance louvers that are molded as an integral part of the fill. This feature makes these towers very forgiving of cold weather operation, even at the low temperature and reduced load conditions encountered in free cooling and other low temperature applications. Nevertheless, during operation in subfreezing weather the opportunity exists for ice to form in the colder regions of the tower.

---

#### △ Note

*Slushy, transitory ice forms routinely in the colder regions of the fill of low temperature towers, and is visible through the tower louvers. Such ice normally has no adverse effect on tower operation, but its appearance should be a signal to the operator to undertake ice control procedures.*

*It is the operator's responsibility to prevent the formation of destructive (hard) ice on the cooling tower fill. Certain guidelines should be followed:*

1. *Do not allow the tower's leaving water temperature to drop below a minimum allowable level—say 36°F to 40°F (2°C to 4.5°C). If such low temperature operation is necessary or beneficial to your process, establish the minimum allowable level as follows:*

*During the coldest days of the first winter of operation, observe whether any ice is forming on the louver face, particularly near the bottom part of the louver face. If hard ice is present on the louvers, you must increase the allowable cold water temperature. If the coldest possible water is beneficial to your process, ice of a mushy consistency can be tolerated—but routine periodic observation is advisable.*

---

#### △ Caution

*If the minimum allowable cold water temperature is established at or near maximum heat load, it should be safe for all operating conditions. However, if established at reduced load, increased heat loads may reintroduce the potential for icing.*

Having established the minimum allowable cold water temperature, maintaining that temperature can be accomplished by fan manipulation, as outlined in **Item 4** under **Tower Operation**. However, *in towers of*

---

## Operation

*more than one cell, where fans are manipulated sequentially, please realize that the water temperature will be significantly lower in the cell or cells operating at the highest fan speed than the net cold water temperature produced by the entire tower would indicate. Wintertime operation of multicell towers at low cold water temperature levels requires that the operator be especially watchful.*

2. As cold air enters the louvers, it causes the water flowing over the fill to be drawn inward toward the center of the tower. Thus, under fan operation, the louvers and lower periphery of the tower structure remain partly dry, seeing only random splashing from within the tower—plus normal atmospheric moisture from the entering air. Such lightly wetted areas are most subject to freezing.

Therefore, if excessive ice forms on the louvers, stop the fan for a few minutes. With the fan off, the water flow will increase in the vicinity of the louvers and reduce the ice buildup.

3. Under extended extreme cold conditions, it may be necessary to operate the fan in reverse. This forces warm air out through the louvers, melting any accumulated ice—adequate heat load must be available. Reversal may be at either full or half speed; however, Marley recommends reversal at half speed. Reverse operation of the fan should be used sparingly and should only be used to control ice, not to prevent it. *Reverse fan operation should not need to exceed 1 or 2 minutes.* Monitoring is required to determine the time required to melt accumulated ice.

---

### △ Warning

***Reverse operation of fans for prolonged periods during subfreezing weather can cause severe damage to fans and fan cylinders. Ice can accumulate inside fan cylinders at fan blade plane of rotation and fan blade tips will eventually strike this ring of ice, damaging the fan blades or cylinder. Ice can also accumulate on fan blades and be thrown off, damaging fan cylinder or blades. Allow a minimum of 10 minute delay between reverse operation and forward operation during subfreezing weather to permit ice to dissipate from fan blades and fan cylinders. See Fan Drive Caution note on page 12 for fan speed change and reversing precautions.***



---

## Operation

4. With no heat load on the circulating water, icing cannot be controlled effectively by air control during freezing weather. ***Towers must not be operated with reduced water rate and/or no heat load during freezing weather.*** If the circulating water system cannot be shut down, water returning from the process should be made to bypass the tower. If a bypass is used, all water must be bypassed without modulation. If the water bypass is directly into the tower's cold water basin, its design must be approved by Marley Engineers.

### **Intermittent Wintertime Operation:**

If periods of shutdown (nights, weekends, etc.) occur during freezing weather, measures must be taken to prevent the water in the cold water basin—and all exposed pipework—from freezing. Several methods are used to combat this, including automatic basin heater systems available from Marley.

---

### **△ Caution**

***Unless some means of freeze prevention is incorporated into your system, the tower basin and exposed pipework should be drained at the beginning of each wintertime shutdown period.***

It is recommended that you discuss your freeze prevention options with your local Marley sales representative.

---

## Maintenance

---

### Water Treatment and Blowdown

#### Maintaining Water Quality:

The steel used in NC towers has been galvanized with a heavy zinc coating averaging 2.0 mils in thickness. NC towers are also available in stainless steel. Other materials used (polyethylene basins, PVC fill, drift eliminators, and louvers, aluminum fans and sheaves, cast Iron Geareducer, etc.) are selected to offer maximum service life in a "normal" cooling tower environment, defined as follows:

- Circulating water with a pH between 6.5 and 8; a chloride content (as NaCl) below 500 ppm; a sulfate content (SO<sub>4</sub>) below 250 ppm; total alkalinity (as CaCO<sub>3</sub>) below 500 ppm; calcium hardness (as CaCO<sub>3</sub>) above 50 ppm; a maximum inlet water temperature not to exceed 125°F (51.7°C); no significant contamination with unusual chemicals or foreign substances; and adequate water treatment to minimize scaling.
- Chlorine (if used) shall be added intermittently, with a free residual not to exceed 1 ppm—maintained for short periods. Excessive chlorine levels may deteriorate sealants and other materials of construction.
- An atmosphere surrounding the tower no worse than "moderate industrial", where rainfall and fog are no more than slightly acid, and they do not contain significant chlorides or hydrogen sulfide (H<sub>2</sub>S).
- Many proprietary chemicals exist for control of scale, corrosion, and biological growth and should be used prudently. Also, combinations of chemicals may cause reactions which reduce treatment effectiveness, and certain chemicals such as surfactants, biocides and antifoams may increase drift rate.

For complete water treatment recommendations and services contact Marley Water Resources, toll free, at 877 800 0929 or contact our local Marley sales representative.

---

#### △ Note

*Unless you purchased the stainless steel structure, your NC tower consists primarily of galvanized steel, therefore your water treatment program must be compatible with zinc. In working with your water treatment supplier, it is important that you recognize the potential effects on zinc of the specific treatment program you choose.*

---

## Maintenance

### Cooling Tower Cleaning:

---

△ **Warning**

*Any evaporative-type cooling tower must be thoroughly cleaned on a regular basis to minimize the growth of bacteria, including Legionella Pneumophila, to avoid the risk of sickness or death. Service personnel must wear proper personal protective equipment during decontamination. Do NOT attempt any service unless the fan motor is locked out.*

Operators of evaporative cooling equipment, such as water cooling towers, should follow maintenance programs which will reduce to an absolute minimum the opportunity for bacteriological contamination. Public Health Service officials have recommended that "good housekeeping" procedures be followed, such as: regular inspections for concentrations of dirt, scale, and algae; periodic flushing and cleaning; and the following of a complete water treatment program including biocidal treatment.

The visual inspection should take place at least once a week during the operating season. The periodic flushing and cleaning should be done before and after each cooling season, but in any event at least twice a year. The louvers, drift eliminators, and easily accessible fill surfaces should be flushed by use of a moderate-pressure water nozzle, being careful not to cause physical damage. A reliable water treatment program should be installed and maintained. Filtration devices may be employed to reduce the suspended solids concentrations, thus increasing the effectiveness of the water treatment program. See Tower Startup instructions on page 9.

### Blowdown:

A cooling tower cools water by continuously causing a portion of it to evaporate. Although the water lost by evaporation is replenished by the makeup system, it exits the tower as pure water—leaving behind its burden of dissolved solids to concentrate in the remaining water. Given no means of control, this increasing concentration of contaminants can reach a very high level.

In order to achieve water quality which is acceptable to the cooling tower (as well as the remainder of your circulating water system), the selected water treatment company must work from a relatively constant level of concentrations. This stabilization of contaminant concentrations is usually accomplished by *blowdown*, which is the constant discharge of a portion of the circulating water to waste. As a rule, acceptable levels on which to base a treatment schedule will be in the range of 2-4 concentrations. The

## Maintenance

following table shows the minimum amount of blowdown (percent of flow) required to maintain different concentrations with various cooling ranges\*:

Cooling Range	Number of Concentrations						
	1.5X	2.0X	2.5X	3.0X	4.0X	5.0X	6.0X
5° F (2.78° C)	.78	.38	.25	.18	.11	.08	.06
10° F (5.56° C)	1.58	.78	.51	.38	.25	.18	.14
15° F (8.33° C)	2.38	1.18	.78	.58	.38	.28	.22
20° F (11.11° C)	3.18	1.58	1.05	.78	.51	.38	.30
25° F (13.89° C)	3.98	1.98	1.32	.98	.64	.48	.38

Multipliers are based on drift of 0.02% of the circulating water rate.

\* Range = Difference between hot water temperature coming to lower and cold water temperature leaving tower.

**EXAMPLE:** 700 GPM (44.2 L/s) circulating rate, 18°F (10°C) cooling range. To maintain 4 concentrations, the required blowdown is 0.458% or .00458 times 700 GPM (44.2 L/s), which is 3.2 GPM (0.2 L/s).

If tower is operated at 4 concentrations, circulating water will contain four times as much dissolved solid as the makeup water, assuming none of the solids form scale or are otherwise removed from the system.

### △ Note

*When water treatment chemicals are added, they should not be introduced into the circulating water system via the cold water basin of the cooling tower. Water velocities are lowest at that point, which results in inadequate mixing.*

### Belt Tensioning

The belts are adjusted by turning the jacking screw at the motor support. Ideal tension is the lowest tension at which the belt will not slip under peak load conditions. Check tension frequently during the first 24-48 hours of run-in operation. Overtensioning shortens belt and bearing life. Keep belts free from foreign material which may cause slip. Never apply belt dressing as this

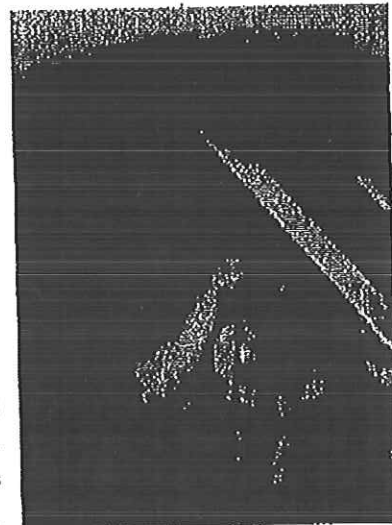

## Maintenance

will damage the belt and cause early failure. A Dodge® V-Belt Tension Tester is an alternate method for tensioning V-belts. Check with your local belt supplier.

### Sheave Alignment

- The motor sheave is to be positioned as close as possible to the motor in order to minimize torque on the motor bushings.
- The motor and fan sheaves may have grooves that are not used. The bottom surface of the motor and fan sheaves must be aligned within  $\frac{1}{8}$ " of each other and level within  $\frac{1}{2}^\circ$  ( $\frac{1}{8}$ " in 12) in order to not adversely affect belt and sheave life.
- Alignment can be achieved by placing a straight edge across the top of the sheaves making sure that it is level and measuring down to the bottom surface of both sheaves at four points.
- The belt is to be located in the lowest set of grooves.

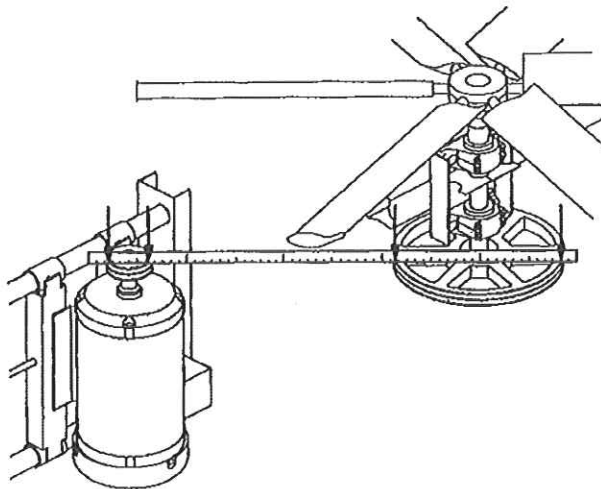

### Bushing Fastener Torque Values

Bushing	Fastener Size	Torque	
		ft·lb <sub>f</sub>	N·m
SH	$\frac{1}{4}$ - 20	6	8
SDS	$\frac{1}{4}$ - 20	6	8
SD	$\frac{1}{4}$ - 20	6	8
SK	$\frac{5}{16}$ - 18	13	18
SF	$\frac{3}{8}$ - 16	22	30
E	$\frac{1}{2}$ - 13	35	48
F	$\frac{5}{16}$ - 12	85	88



---

## Maintenance

### Schedule of Tower Maintenance

Some maintenance procedures may require maintenance personnel to enter the tower. Each cased face of the tower has a door for access to the interior of the tower.

---

△ Warning

*The purchaser or owner is responsible for providing a safe method for entering or exiting the access door.*

Included with this instruction packet are separate Manuals on each major operating component of the tower, and it is recommended that you read them thoroughly. *Where discrepancies may exist, the separate component User Manuals will take precedence.*

The following is recommended as a minimum routine of scheduled maintenance:

---

△ Warning

*Always shut off electrical power to the tower fan motor prior to performing any inspections that may involve physical contact with the mechanical or electrical equipment in or on the tower. Lock out and tag out any electrical switches to prevent others from turning the power back on. Service personnel must wear proper personal protective clothing and equipment.*

**Weekly:** Inspect for bacterial growth and general operation conditions. Bacterial growth should be reported to your water treatment expert for immediate attention.

**Monthly (Weekly at start up):** Observe, touch, and listen to the tower. Become accustomed to its normal appearance, sound, and level of vibration. Abnormal aspects relating to the rotating equipment should be considered reason to shut down the tower until the problem can be located and corrected. Observe the operation of the motor, drive train and fan. Become familiar with the normal operating temperature of the motor, as well as the sight and sound of all components as a whole.

If equipped, check for Geareducer oil leaks. Check the Geareducer as well as any optional oil lines to external oil dipstick/sight glass.

Inspect louvers, drift eliminators and basin trash screens and remove any debris or scale which may have accumulated. Replace any damaged or worn out components. Use of high-pressure water may damage the eliminator and louver material.



---

## Maintenance

Observe operation of the float valve. Depress the operating lever to make sure that the valve is operating freely. Inspect the suction screen for plugging. Remove any debris that may have accumulated.

Check for any buildup of silt on the floor of the cold water basin. Make note of the amount, if any, so future inspections will enable you to determine the rate at which it is forming.

**Every 3 month:** If equipped, lubricate fan shaft bearings. While rotating equipment by hand, grease the bearings until a bead forms around the seals—a maximum charge of 0.55 ounces is recommended. Chevron SRI-2 grease is recommended.

**Semi-Annually:** Relubricate motor according to the manufacturer's instructions. See instructions on this page for towers with the motor located outside the plenum option.

If equipped, check the belt tension and condition.

If equipped, check Geareducer oil level. Shut down the unit and allow 5 minutes for the oil level to stabilize. Add oil if required.

Check to see that all bolts are tight in the fan and mechanical equipment region, including the fan cylinder and fan guard. Refer to component User Manuals for torque values.

Clean and disinfect cooling tower with biocides. Systems with biofouling, high general bacterial counts, or positive cultures of legionella may require additional cleaning. Refer to "Cooling Tower Cleaning" section—page 20. Consult your water treatment expert as to prudent biological evaluation testing.

---

### △ Note

*Geareducer models used on NC cooling towers are designed for 5-year oil change intervals. To maintain five-year change intervals, use only oil designed specifically for these Geareducers. If, after five years, turbine-type mineral oil is used, the oil must be changed semiannually. Refer to the Geareducer Manual for oil recommendations and further instructions.*

**Annually:** Inspect the tower thoroughly, making maximum use of instructions given in the separate service manuals. Check structural bolted connections and tighten as required. Make preventive maintenance repairs as necessary.

**Every 5 Years:** If equipped, change Geareducer oil. Refer to the *Geareducer User Manual* for instructions.

---

## Maintenance

---

### Motor Relubrication Instructions

*Motor located outside plenum option*

△ **Note**

**Open and lock out disconnect switch to make certain motor cannot be started.**

1. Remove guard as shown on the next page. Opposite end motor bearing is accessible from outside the tower.

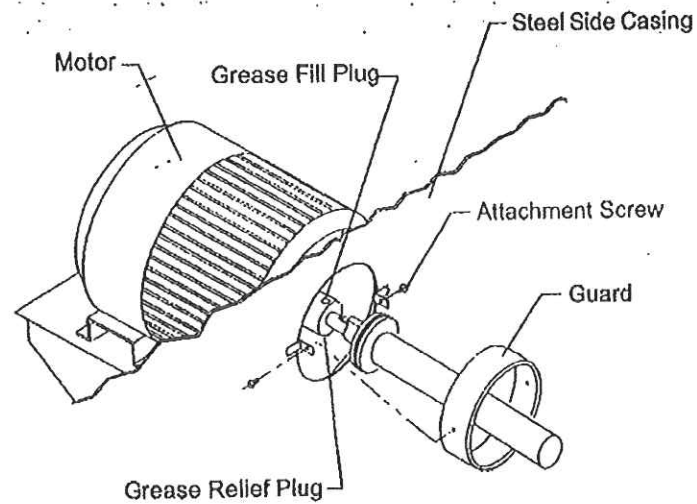

2. Remove grease fill and relief plugs at both shaft extension end and opposite end bearings and remove hardened grease, using clean wire.
3. Insert grease fittings in grease fill openings and add grease until grease is forced out through relief openings.
4. Replace fill plugs and operate mechanical equipment 30 minutes to one hour to purge excess grease at grease relief opening.
5. Reinstall grease relief plugs and reinstall guard.
6. Resume normal tower operation.

---

## Maintenance

### Seasonal Shutdown Instructions

When the system is to be shut down for an extended period of time, it is recommended that the entire system (cooling tower, system piping, heat exchangers, etc.) be drained. Leave the basin drains open.

During shutdown, clean the tower (see Warning, page 19) and make any necessary repairs. Pay particular attention to mechanical equipment supports and coupling (or drive shafts).

Following each year's shutdown and cleaning, inspect the tower's metal surfaces for evidence of the need to apply a protective coating. Do not misinterpret grime—and transient rust from the piping system—as a need to have the tower painted. If relatively bright metal can be exposed by cleaning, consider that the galvanizing has remained effective. Unless there is evidence of a generalized failure of the galvanizing, localized touch-up should be all that is required.

---

#### △ Note

*To the extent that the galvanizing (zinc coating) still exists, paint will not adhere to it readily. Contact the manufacturer of the coating you intend to use for instructions.*

**Tower framework:** Check structural bolted connections and tighten as required.

**Fans:** Check fan assembly bolting and tighten as required. Use torque values prescribed in the Fan User Manual.

**Fan shaft bearings:** If equipped, lubricate fan shaft bearings at close of each operating season—see page 23.

**Electric motors:** Clean and lubricate motor at close of each operating season (refer to motor manufacturer's recommendations.) Check motor anchor bolts and tighten as required. See Page 24 for towers with motor located outside the plenum option.

---

#### △ Caution

*Do not start motor before determining that there will be no interference with free rotation of the fan drive.*

The motor should be operated for three hours at least once a month. This serves to dry out windings and re-lubricate bearing surfaces (refer to Marley "Electric Motor User Manual" Manual 92-1475).

---

## Maintenance

At start of new operating season, make sure bearings are adequately lubricated before returning motor to service.

### **Prolonged Shutdown**

If shutdown period is longer than seasonal, contact your Marley sales engineer for additional information.

### **Marley Services**

Marley's interest in your NC cooling tower *does not* end with the sale. Having conceived, designed, and manufactured the most reliable and longest-lasting cooling tower of its class, we want to make sure that you gain the maximum possible benefit from its purchase.

Therefore, the following services are available which are intended to: assure the maximum possible service life under your operating conditions; tailor the operating characteristics to your specific needs; and maintain consistently optimum thermal performance capability. They are available by contacting your Marley sales representative.

**Replacement parts:** A complete stock of parts and components is maintained at one or more of the various Marley plants. In cases of emergency, they can normally be shipped within 24 hours—by air freight if necessary. However, you would obviously benefit from anticipating your need in advance, thus avoiding the cost of special handling.

Be sure to mention your tower serial number (from the tower nameplate) when ordering parts.

**Periodic maintenance:** You may wish to contract with Marley for regularly scheduled visits—for the purpose of inspecting and reporting your tower's condition—to make recommendations intended to prevent emergencies—and to perform maintenance considered outside the norm.

This service is not intended to replace the important function performed by your maintenance staff. Their attention assures the tower's routine operating performance, and is invaluable. However, Marley recognizes that the unusual manner in which a cooling tower performs its function—as well as the unique forces which act upon it—may be considerations which occasionally require the services of an expert technician.

---

## Additional Information

**Increased load requirements:** NC towers are designed so that cells of either equal or unequal capacity can be added in the future. This allows you to compensate for the load increases that normally occur with the replacement or addition of production equipment—and still retain continuity with respect to your cooling tower system.

**Tower rebuilding:** Marley routinely rebuilds and upgrades cooling towers of *all* materials and manufacture. If your tower ever reaches the limit of its service life, we recommend that you investigate the cost of rebuilding before you routinely order a new replacement tower.

Each NC tower includes a document package containing general orientation drawings, "**NC Field Installation Manual**" *Assembly Instructions*, and tower component manuals. *These documents contain important information relating to safe installation and operation of the cooling tower.* Field installation is always required for fan guards, piping inlets and piping outlets. Some optional accessories, such as valves, handrails, ladders and safety cages may also require field installation. If installation details are not covered in the "**NC Field Installation Manual**" a separate installation drawing or manual for each purchased option is included in the document package along with bills of material. If you have purchased an option and can't find the appropriate installation drawing, contact your local Marley office or representative before proceeding.

In addition to these specific documents, Marley publishes numerous technical reports including more detailed information on a variety of cooling tower operation and service topics. Your Marley office or representative will be happy to give you copies of these reports at no charge.

For complete parts and service assistance, contact the Marley sales or representative office in your area. If you need help locating the office nearest you, please phone 800 462 7539 or check the internet at [www.marleyct.com](http://www.marleyct.com).

## Troubleshooting

Trouble	Cause	Remedy
Motor Will Not Start	Power not available at motor terminals	<ul style="list-style-type: none"> <li>Check power at starter. Correct any bad connections between the control apparatus and the motor.</li> <li>Check starter contacts and control circuit. Reset overloads, close contacts, reset tripped switches or replace failed control switches.</li> <li>If power is not on all leads at starter, make sure overload and short circuit devices are in proper condition.</li> </ul>
	Wrong connections	Check motor and control connections against wiring diagrams.
	Low voltage	Check nameplate voltage against power supply. Check voltage at motor terminals.
	Open circuit in motor winding	Check stator windings for open circuits.
	Motor or fan drive stuck	Disconnect motor from load and check motor and Geareducer for cause of problem.
Unusual Motor Noise	Rotor defective	Look for broken bars or rings.
	Motor running single-phase	Stop motor and attempt to start it. Motor will not start if single-phased. Check wiring, controls, and motor.
	Motor leads connected incorrectly	Check motor connections against wiring diagram on motor.
	Bad bearings	Check lubrication. Replace bad bearings.
	Electrical unbalance	Check voltages and currents of all three lines. Correct if required.
Motor Runs Hot	Air gap not uniform	Check and correct bracket fits or bearing.
	Rotor unbalance	Rebalance.
	Cooling fan hitting end bell guard	Reinstall or replace fan.
	Wrong voltage or unbalanced voltage	Check voltage and current of all three lines against nameplate values.
	Overload	Check fan blade pitch. See Fan Service Manual. Check for drag in fan drive train as from damaged bearings.
	Wrong motor RPM	Check nameplate against power supply. Check RPM of motor and gear ratio.
	Bearings overgreased	Remove grease reliefs. Run motor up to speed to purge excessive grease.
	Wrong lubricant in bearings	Change to proper lubricant. See motor manufacturer's instructions.
	One phase open	Stop motor and attempt to start it. Motor will not start if single-phased. Check wiring, controls, and motor.
	Poor ventilation	Clean motor and check ventilation openings. Allow ample ventilation around motor.
Motor Does Not Come Up To Speed	Winding fault	Check with Ohmmeter.
	Bent motor shaft	Straighten or replace shaft.
	Insufficient grease	Remove plugs and regrease bearings.
	Too frequent starting or speed changes	Limit cumulative acceleration time to a total of 30 seconds/hr. Set on/off or speed change set points farther apart. Consider installing a Marley VFD drive for fine temperature control.
	Deterioration of grease, or foreign material in grease	Flush bearings and relubricate.
	Bearings damaged	Replace bearings.
	Voltage too low at motor terminals because of line drop	Check transformer and setting of taps. Use higher voltage on transformer terminals or reduce loads. Increase wire size or reduce inertia.
Wrong Rotation (Motor)	Broken Rotor bars	Look for cracks near the rings. A new rotor may be required. Have motor service person check motor.
	Wrong sequence of phases	Switch any two of the three motor leads.



## Troubleshooting

Trouble	Cause	Remedy
Geareducer Noise	Geareducer bearings	If new, see if noise disappears after one week of operation. Drain, flush, and refill Geareducer. See Geareducer Service Manual. If still noisy, replace.
	Gears	Correct tooth engagement. Replace badly worn gears. Replace gears with broken or damaged teeth.
	Loose bolts and cap screws	Tighten all bolts and cap screws on all mechanical equipment and supports.
	Unbalanced drive shaft or worn couplings	Make sure motor and Geareducer shafts are in proper alignment and "match marks" properly matched. Repair or replace worn couplings. Rebalance drive shaft by adding or removing weights from balancing cap screws. See Drive Shaft Service Manual.
Unusual Fan Drive Vibration	Fan	Make certain all blades are as far from center of fan as safety devices permit. All blades must be pitched the same. See Fan Service Manual. Clean off deposit build-up on blades.
	Worn Geareducer bearings	Check fan and pinion shaft endplay. Replace bearings as necessary.
	Worn fan shaft bearings—belt drive	Check fan shaft endplay. Replace bearings as necessary.
	Unbalanced motor	Disconnect load and operate motor. If motor still vibrates, rebalance rotor.
	Bent Geareducer shaft	Check fan and pinion shaft with dial indicator. Replace if necessary.
	Blade rubbing inside of fan cylinder	Adjust cylinder to provide blade lip clearance.
	Loose bolts in blade clamps	Check and tighten if necessary.
Fan Noise	Fan shaft bearings—belt drive	Grease bearings
Scale or foreign substance in circulating water system	Insufficient blowdown	See "Water Treatment" section of this manual
	Water treatment deficiency	Consult competent water treating specialist. See "Water Treatment" section of this manual
Cold Water Temperature Too Warm (See "Tower Operation")	Entering wet bulb temp. is above design	Check to see if local heat sources are affecting tower. See if surrounding structures are causing recirculation of tower discharge air. Discuss remedy with Marley representative.
	Design wet bulb temp. was too low	May have to increase tower size. Discuss remedy with Marley representative.
	Actual process load greater than design	May have to increase tower size. Discuss remedy with Marley representative.
	Overpumping	Reduce water flow rate over tower to design conditions.
	Tower starved for air	Check motor current and voltage to be sure of correct contract horsepower. Re-pitch fan blades if necessary. Clean louvers, fill and eliminators. Check to see if nearby structures or enclosing walls are obstructing normal airflow to tower. Discuss remedy with Marley representative.
Excessive Drift Exiting Tower	Distribution basins overflowing	Reduce water flow rate over tower to design conditions. Be sure hot water basin nozzles are in place and not plugged.
	Faulty drift elimination	Check to see that integral fill, louvers, and eliminators are clean, free of debris, and installed correctly. If drift eliminators are separate from fill, make sure they are correctly installed in place. Clean if necessary. Replace damaged or worn out components.

## Maintenance Schedule

Service	Monthly	Startup	Shutdown	Semi-annually
Inspect General Condition and Operation	X	X		
<b>Observe Operation of:</b>				
Motor, Coupling, Geareducer and Fan	X	X		
Makeup Valve	X	X		
<b>Inspect and Clean as Necessary:</b>				
PVC Air Inlet Louvers	X	X		
PVC Drift Eliminators	X	X		
Cold Water Basin and Outlet	X	X	X	X
Hot Water Basins	X	X		
Fan Motor Exterior	X	X		
<b>Check:</b>				
Cold Water Basin Level	X	X		
Blowdown-adjust as required	X	X		
<b>Check Geareducer for:</b>				
Oil Leaks	X	X		
Proper Oil Level	X	X		
Loose Bolts or Oil Plug		X		X
Plugged Oil Lines or Vent		X		X
Change Geareducer Oil			5-years	
Thoroughly Inspect Mechanical Couplings		X	X	X
<b>Check Belt Drive System for:</b>				
Belt Tension and Condition		X		X
Sheave Bushing Fastener Torque		X		X
Fan Shaft Bearing Lubrication (every 3 mo)		X		X
<b>Check and Tighten as Required:</b>				
Mechanical Equipment Bolts		X	X	X
Motor Anchor Bolts		X	X	X
Tower Framework Structural Bolts		X	X	X
Fan Assembly Bolts			X	X
Inspect Metal Surfaces and Touchup			X	
Motor Operation Required (minimum)			3 hrs/month	



7401 W 129 Street • Overland Park, KS 66213 • 913 664 7400  
www.marleyct.com • email: info@marleyct.com

In the interest of technological progress, all products are  
subject to design and/or material change without notice.

©2003 Marley Cooling Technologies, Inc.

Printed in USA

## Maintenance Schedule

↓ use  
This  
Schedule

Service	Monthly	Startup	Shutdown	Semi-annually
Inspect General Condition and Operation	x	x		
<b>Observe Operation of:</b>				
Motor, Coupling, Geareducer and Fan	x	x		
Makeup Valve	x	x		
<b>Inspect and Clean as Necessary:</b>				
PVC Air Inlet Louvers	x	x		
PVC Drift Eliminators	x	x		
Cold Water Basin and Outlet	x	x	x	x
Hot Water Basins	x	x		
Fan Motor Exterior	x	x		
<b>Check:</b>				
Cold Water Basin Level	x	x		
Blowdown-adjust as required	x	x		
<b>Check Geareducer for:</b>				
Oil Leaks	x	x		
Proper Oil Level	x	x		
Loose Bolts or Oil Plug		x		x
Plugged Oil Lines or Vent		x		x
Change Geareducer Oil			5-years	
Thoroughly Inspect Mechanical Couplings		x	x	x
<b>Check Belt Drive System for:</b>				
Belt Tension and Condition		x		x
Sheave Bushing Fastener Torque		x		x
Fan Shaft Bearing Lubrication (every 3 mo)		x		x
<b>Check and Tighten as Required:</b>				
Mechanical Equipment Bolts		x	x	x
Motor Anchor Bolts		x	x	x
Tower Framework Structural Bolts		x	x	x
Fan Assembly Bolts		x	x	x
Inspect Metal Surfaces and Touchup		x	x	
Motor Operation Required (minimum)		x	3 hrs/month	

State of West Virginia  
Department of Administration

General Services Division  
GSD136427 Bldg 11 HVAC  
Maintenance Service

**GSD136427 Attachment C: Bid Form**

**Bidder's Company Name:** Alpha Mechanical Service, Inc.

**Bidder's Address:** 401 27th Street

Dunbar, WV 25064

**Remittance Address:** 7200 Distribution Drive

**(if different)**

Louisville, KY.40258-2827

**Phone Number:** (304) 766-1006

**Fax Number:** (304) 766-1008

**Email Address:** melisa.shoots@aamservice.com

**WV Contractor's License Number:** WV036853

We, the undersigned, having examined the site and being familiar with the local conditions affecting the cost of the work and also being familiar with the general conditions to bidders, drawings, and specifications, hereby propose to furnish all materials, equipment, and labor to complete all work in a workmanlike manner, as described in the Bidding Documents.

**TOTAL CONTRACT BID** (Total to be written in words and numbers)

Thirty six thousand four hundred twenty dollars and zero cents

**(**\$36,420.00**)**

State of West Virginia  
Department of Administration

General Services Division  
GSD136427 Bldg 11 HVAC  
Maintenance Service

### References

Reference Name: David Parsons/Roger Wines  
Position: Administrator/Building Supervisor  
Address: WV State Capital  
Telephone Number: (304) 558-2317  
Project Name: Bldg 5, 2011 Annual Boiler Inspection  
Project Description: Annual Boiler Inspection & Cleaning

Reference Name: Dave Henderson  
Position: Director of Maintenance, Summersville Hospital  
Address: Summersville, WV  
Telephone Number: (304) 872-8400  
Project Name: Annual Boiler Services  
Project Description: Boiler Maintenance Contract Services

Reference Name: Tim Lee  
Position: Director of Maintenance, Thomas Memorial Hospital  
Address: South Charleston, WV  
Telephone Number: (304) 766-3600  
Project Name: Annual Boiler Services  
Project Description: Boiler Maintenance Contract Services

**CERTIFICATION AND SIGNATURE PAGE**

By signing below, I certify that I have reviewed this Solicitation in its entirety; understand the requirements, terms and conditions, and other information contained herein; that I am submitting this bid or proposal for review and consideration; that I am authorized by the bidder to execute this bid or any documents related thereto on bidder's behalf; that I am authorized to bind the bidder in a contractual relationship; and that to the best of my knowledge, the bidder has properly registered with any State agency that may require registration.

Alpha Mechanical Service, Inc.

(Company)



(Authorized Signature)

Herman J. Rhodes, Jr., President

(Representative Name, Title)

(502) 968-0121

(Phone Number)

(502) 968-8116

(Fax Number)

February 20, 2013

(Date)



**ADDENDUM ACKNOWLEDGEMENT FORM**

**SOLICITATION NO.:** GSD136427

**Instructions:** Please acknowledge receipt of all addenda issued with this solicitation by completing this addendum acknowledgment form. Check the box next to each addendum received and sign below. Failure to acknowledge addenda may result in bid disqualification.

**Acknowledgment:** I hereby acknowledge receipt of the following addenda and have made the necessary revisions to my proposal, plans and/or specification, etc.

**Addendum Numbers Received:**

(Check the box next to each addendum received)

- |   |  |
|---|--|
| <input type="checkbox"/> Addendum No. 1 | <input type="checkbox"/> Addendum No. 6  |
| <input type="checkbox"/> Addendum No. 2 | <input type="checkbox"/> Addendum No. 7  |
| <input type="checkbox"/> Addendum No. 3 | <input type="checkbox"/> Addendum No. 8  |
| <input type="checkbox"/> Addendum No. 4 | <input type="checkbox"/> Addendum No. 9  |
| <input type="checkbox"/> Addendum No. 5 | <input type="checkbox"/> Addendum No. 10 |

I understand that failure to confirm the receipt of addenda may be cause for rejection of this bid. I further understand that any verbal representation made or assumed to be made during any oral discussion held between Vendor's representatives and any state personnel is not binding. Only the information issued in writing and added to the specifications by an official addendum is binding.

Alpha Mechanical Service, Inc.

Company



Herman J. Rhodes, Jr. Authorized Signature

President

February 20, 2013

Date

**NOTE:** This addendum acknowledgment should be submitted with the bid to expedite document processing.

RFQ No. GSD136427

STATE OF WEST VIRGINIA  
Purchasing Division  
**PURCHASING AFFIDAVIT**

**MANDATE:** Under W. Va. Code §5A-3-10a, no contract or renewal of any contract may be awarded by the state or any of its political subdivisions to any vendor or prospective vendor when the vendor or prospective vendor or a related party to the vendor or prospective vendor is a debtor and: (1) the debt owed is an amount greater than one thousand dollars in the aggregate; or (2) the debtor is in employer default.

**EXCEPTION:** The prohibition listed above does not apply where a vendor has contested any tax administered pursuant to chapter eleven of the W. Va. Code, workers' compensation premium, permit fee or environmental fee or assessment and the matter has not become final or where the vendor has entered into a payment plan or agreement and the vendor is not in default of any of the provisions of such plan or agreement.

**DEFINITIONS:**

**"Debt"** means any assessment, premium, penalty, fine, tax or other amount of money owed to the state or any of its political subdivisions because of a judgment, fine, permit violation, license assessment, defaulted workers' compensation premium, penalty or other assessment presently delinquent or due and required to be paid to the state or any of its political subdivisions, including any interest or additional penalties accrued thereon.

**"Employer default"** means having an outstanding balance or liability to the old fund or to the uninsured employers' fund or being in policy default, as defined in W. Va. Code § 23-2c-2, failure to maintain mandatory workers' compensation coverage, or failure to fully meet its obligations as a workers' compensation self-insured employer. An employer is not in employer default if it has entered into a repayment agreement with the Insurance Commissioner and remains in compliance with the obligations under the repayment agreement.

**"Related party"** means a party, whether an individual, corporation, partnership, association, limited liability company or any other form or business association or other entity whatsoever, related to any vendor by blood, marriage, ownership or contract through which the party has a relationship of ownership or other interest with the vendor so that the party will actually or by effect receive or control a portion of the benefit, profit or other consideration from performance of a vendor contract with the party receiving an amount that meets or exceeds five percent of the total contract amount.

**AFFIRMATION:** By signing this form, the vendor's authorized signer affirms and acknowledges under penalty of law for false swearing (W. Va. Code §61-5-3) that neither vendor nor any related party owe a debt as defined above and that neither vendor nor any related party are in employer default as defined above, unless the debt or employer default is permitted under the exception above.

**WITNESS THE FOLLOWING SIGNATURE:**

Vendor's Name: Alpha Mechanical Service, Inc.

Authorized Signature: Herman J. Rhodes, Jr. Date: February 20, 2013  
Herman J. Rhodes, Jr., President

State of Kentucky

County of Jefferson, to-wit:

Taken, subscribed, and sworn to before me this 20 day of February, 2013.

My Commission expires 4/7/2016, 2016.

AFFIX SEAL HERE

NOTARY PUBLIC

Jane Black



**State of West Virginia  
DRUG FREE WORKPLACE CONFORMANCE AFFIDAVIT  
West Virginia Code §21-1D-5**

STATE OF Kentucky

COUNTY OF Jefferson, TO-WIT:

I, Herman J. Rhodes, Jr., President, after being first duly sworn, depose and state as follows:

- 1. I am an employee of Alpha Mechanical Service, Inc.; and,  
(Company Name)
- 2. I do hereby attest that Alpha Mechanical Service, Inc.  
(Company Name)

maintains a valid written drug free workplace policy and that such policy is in compliance with **West Virginia Code §21-1D-5**.

The above statements are sworn to under the penalty of perjury.

Alpha Mechanical Service, Inc.

(Company Name)

By: Herman J. Rhodes, Jr.  
Herman J. Rhodes, Jr.

Title: President

Date: February 20, 2013

Taken, subscribed and sworn to before me this 20 day of February, 2013

By Commission expires 4/7/2016

(Seal)

Dawn Block  
(Notary Public)

**THIS AFFIDAVIT MUST BE SUBMITTED WITH THE BID IN ORDER TO COMPLY WITH WV CODE PROVISIONS. FAILURE TO INCLUDE THE AFFIDAVIT WITH THE BID SHALL RESULT IN DISQUALIFICATION OF THE BID.**

# THE AMERICAN INSTITUTE OF ARCHITECTS

## AIA Document A310 Bid Bond

KNOW ALL MEN BY THESE PRESENTS, THAT WE Alpha Mechanical Service, Inc.

7200 Distribution Drive, Louisville, KY 40258

as Principal, hereinafter called the Principal, and North American Specialty Insurance Company

650 Elm Street, Manchester, NH 03101

a corporation duly organized under the laws of the State of NH

as Surety, hereinafter called the Surety, are held and firmly bound unto Department of Administration Purchasing Division

2019 Washington Street East, Charleston, WV 25304

as Obligee, hereinafter called the Obligee, in the sum of Five Percent of Amount Bid

Dollars (\$ 5% ),

for the payment of which sum well and truly to be made, the said Principal and the said Surety, bind ourselves, our heirs, executors, administrators, successors and assigns, jointly and severally, firmly by these presents.

WHEREAS, the Principal has submitted a bid for Annual Cleaning and Maintenance of Towers in Building 11

NOW, THEREFORE, if the Obligee shall accept the bid of the Principal and the Principal shall enter into a Contract with the Obligee in accordance with the terms of such bid, and give such bond or bonds as may be specified in the bidding or Contract Documents with good and sufficient surety for the faithful performance of such Contract and for the prompt payment of labor and materials furnished in the prosecution thereof, or in the event of the failure of the Principal to enter such Contract and give such bond or bonds, if the Principal shall pay to the Obligee the difference not to exceed the penalty hereof between the amount specified in said bid and such larger amount for which the Obligee may in good faith contract with another party to perform the Work covered by said bid, then this obligation shall be null and void, otherwise to remain in full force and effect.

Signed and sealed this 21st day of February, 2013

Melvin J. Shrocks

(Witness)

Alpha Mechanical Service, Inc.

(Principal)

(Seal)

By: Herman J. Rhodes, Jr.

Herman J. Rhodes, Jr., President

2/20/13  
(Title)

North American Specialty Insurance Company

(Surety)

(Seal)

By: Heather Burroughs

Attorney-in-Fact Heather Burroughs

(Title)



Kitara A. Smith

(Witness)

NAS SURETY GROUP

NORTH AMERICAN SPECIALTY INSURANCE COMPANY  
WASHINGTON INTERNATIONAL INSURANCE COMPANY

GENERAL POWER OF ATTORNEY

KNOW ALL MEN BY THESE PRESENTS, THAT North American Specialty Insurance Company, a corporation duly organized and existing under laws of the State of New Hampshire, and having its principal office in the City of Manchester, New Hampshire, and Washington International Insurance Company, a corporation organized and existing under the laws of the State of New Hampshire and having its principal office in the City of Schaumburg, Illinois each does hereby make, constitute and appoint: Heather Burroughs

Its true and lawful Attorney-in-Fact, to make, execute, seal and deliver, for and on its behalf and as its act and deed, the following surety bond:

**Principal:** Alpha Mechanical Service, Inc. **Bond Number:** Bid Bond  
**Obligee:** Department of Administration Purchasing Division **Bond Amount:** See Bond Form  
**Bond Description:** Annual Cleaning and Maintenance of Towers in Building 11

Provided that no bond or undertaking or contract of suretyship executed under this authority shall exceed the amount of:  
FIFTY MILLION (\$50,000,000) DOLLARS

This Power of Attorney is granted and is signed by facsimile under and by the authority of the following Resolutions adopted by the Boards of Directors of both North American Specialty Insurance Company and Washington International Insurance Company at meetings duly called and held on the 9<sup>th</sup> of May, 2012:

"RESOLVED, that any two of the Presidents, any Managing Director, any Senior Vice President, any Vice President, any Assistant Vice President, the Secretary or any Assistant Secretary be, and each or any of them hereby is authorized to execute a Power of Attorney qualifying the attorney named in the given Power of Attorney to execute on behalf of the Company bonds, undertakings and all contracts of surety, and that each or any of them hereby is authorized to attest to the execution of any such Power of Attorney and to attach therein the seal of the Company; and it is

FURTHER RESOLVED, that the signature of such officers and the seal of the Company may be affixed to any such Power of Attorney or to any certificate relating thereto by facsimile, and any such Power of Attorney or certificate bearing such facsimile signatures or facsimile seal shall be binding upon the Company when so affixed and in the future with regard to any bond, undertaking or contract of surety to which it is attached."



By [Signature]  
Steven P. Anderson, Senior Vice President of Washington International Insurance Company  
& Senior Vice President of North American Specialty Insurance Company

By [Signature]  
David M. Layman, Vice President of Washington International Insurance Company  
& Vice President of North American Specialty Insurance Company



IN WITNESS WHEREOF, North American Specialty Insurance Company and Washington International Insurance Company have caused their official seals to be hereunto affixed, and these presents to be signed by their authorized officers this 25th day of May 20 12.

North American Specialty Insurance Company  
Washington International Insurance Company

State of Illinois ss:  
County of Cook

On this 25th day of May 20 12, before me, a Notary Public personally appeared Steven P. Anderson, Senior Vice President of Washington International Insurance Company and Senior Vice President of North American Specialty Insurance Company and David M. Layman, Vice President of Washington International Insurance Company and Vice President of North American Specialty Insurance Company, personally known to me, who being by me duly sworn, acknowledged that they signed the above Power of Attorney as officers of and acknowledged said instrument to be the voluntary act and deed of their respective companies.



[Signature]  
Donna D. Sklens, Notary Public

I, Jeffrey Goldberg, the duly elected Assistant Secretary of North American Specialty Insurance Company and Washington International Insurance Company, do hereby certify that the above and foregoing is a true and correct copy of a Power of Attorney given by said North American Specialty Insurance Company and Washington International Insurance Company, which is still in full force and effect.

IN WITNESS WHEREOF, I have set my hand and affixed the seals of the Companies this 21st day of February, 2013.

[Signature]  
Jeffrey Goldberg, Vice President & Assistant Secretary of Washington International Insurance Company & Assistant Secretary of North American Specialty Insurance Company

WV-75  
Created 07/18/12



State of West Virginia

## PURCHASING DIVISION

### Construction Bid Submission Review Form

*This list has been provided for informational purposes only and is not to be construed as a complete list of request for quotation or bidding requirements for any individual construction project. This list does not and cannot include every item, mistake or oversight that could cause a contractor's bid to be disqualified. Rather, this list is intended to draw attention to some of the most common problems that the Purchasing Division encounters in the bidding process for construction projects. All potential bidders must read the request for quotation, all additional documents, and all instructions relating thereto ("Bid Documents") in their entirety to identify the actual request for quotation and bidding requirements. Failure to read the Bid Documents in their entirety and comply with the stated requirements contained therein may result in bid disqualification.*

#### Errors That Shall Be Reason for Immediate Bid Disqualification

1. Failure to attend a mandatory pre-bid meeting
2. Failure to sign the bid
3. Failure to supply West Virginia contractor's license # on bid
4. Failure to supply a signed drug free workplace affidavit with the bid
5. Failure to supply a valid bid bond or other surety approved by the State of West Virginia
6. Failure to meet any mandatory requirement of the RFQ
7. Failure to acknowledge receipt of Addenda (only if stipulated as mandatory)
8. Failure to submit bid prior to the bid opening date and time
9. Federal debarment
10. State of West Virginia debarment or suspension

#### Errors that May Be Reason for Bid Disqualification Before Contract Award

1. Uncontested debt to the State exceeding \$1,000.00 (must be cured prior to award)
2. Workers' Compensation or Unemployment Compensation delinquency (must be cured prior to award)
3. Not registered as a vendor with the State (must be cured prior to award)
4. Failure to obtain required bonds and/or insurance
5. Failure to provide the sub-contractor listing within 1 business day of bid opening.
6. Failure to use the provided RFQ form (only if stipulated as mandatory).