



State of West Virginia  
 Department of Administration  
 Purchasing Division  
 2019 Washington Street East  
 Post Office Box 50130  
 Charleston, WV 25305-0130

**Solicitation**

NUMBER  
 EDD392953

PAGE  
 1

ADDRESS CORRESPONDENCE TO ATTENTION OF:  
 CONNIE OSWALD  
 304-558-2157

V  
E  
N  
D  
O  
R

CDW  
 2 ENTERPRISE DRIVE, STE 404  
 SHELTON, CT 06484

S  
H  
I  
P  
T  
O

DEPARTMENT OF EDUCATION  
 BUILDING 6  
 1900 KANAWHA BOULEVARD, EAST  
 CHARLESTON, WV  
 25305-0330

DATE PRINTED  
 05/16/2013

BID OPENING DATE: 06/13/2013 BID OPENING TIME 1:30PM

LINE	QUANTITY	UOP	CAT. NO.	ITEM NUMBER	UNIT PRICE	AMOUNT
THE STATE OF WEST VIRGINIA AND ITS AGENCY THE WEST VIRGINIA DEPARTMENT OF EDUCATION REQUEST A QUOTE TO PROVIDE AN INTERNET FILTERING AND REPORTING SOLUTION THAT CONSISTS OF SOFTWARE, LICENSING, SOFTWARE UPGRADES/UPDATES, DATABASE UPDATES AND TECHNICAL SUPPORT PER THE SPECIFICATIONS AND INSTRUCTIONS TO BIDDERS ATTACHED.  BID OPENING: JUNE 13, 2013 AT 1:30 PM						
C001	1	JB		920-45		
INTERNET FILTERING & REPORTING SOLUTION THAT CONSISTS OF SOFTWARE, LICENSING, SOFTWARE UPGRADES/UPDATES, DATABASE UPDATES AND TECHNICAL SUPPORT.						
***** THIS IS THE END OF RFQ EDD392953 *****						TOTAL: \$560,437.10
SIGNATURE		* TELEPHONE 866.850.5724		DATE 6/12/2013		
TITLE John Loughlin - Supervisor, Proposals		FEIN 36-4230110**		ADDRESS CHANGES TO BE NOTED ABOVE		

WHEN RESPONDING TO SOLICITATION, INSERT NAME AND ADDRESS IN SPACE ABOVE LABELED 'VENDOR'

\*For any services to be given, a statement of work must be drafted, mutually agreed upon and signed by each party.  
 \*Except with respect to the product specifications, quantities and prices included in this response, the terms and conditions found at <http://www.cdwg.com/content/terms-conditions/product-sales.asp> apply to this submission unless the parties otherwise agree in a separate writing.  
 For more information or to initiate an agreement with Seller, please contact:  
 Tara Barbieri  
 E-mail: tarabar@cdwg.com  
 \*\* CDW Government LLC is disregarded as an entity separate from its owner (CDW LLC) for Federal income tax purposes. Accordingly, for all issues concerning Federal income taxes please revert to the CDW LLC (parent) FEIN: 36-3310735. CDW LLC is a single-member LLC that elects to file Federal income taxes as a corporation.

**INSTRUCTIONS TO VENDORS SUBMITTING BIDS**

1. **REVIEW DOCUMENTS THOROUGHLY:** The attached documents contain a solicitation for bids. Please read these instructions and all documents attached in their entirety. These instructions provide critical information about requirements that if overlooked could lead to disqualification of a Vendor's bid. All bids must be submitted in accordance with the provisions contained in these instructions and the Solicitation. Failure to do so may result in disqualification of Vendor's bid.
2. **MANDATORY TERMS:** The Solicitation may contain mandatory provisions identified by the use of the words "must," "will," and "shall." Failure to comply with a mandatory term in the Solicitation will result in bid disqualification.
3. **PREBID MEETING:** The item identified below shall apply to this Solicitation.

A pre-bid meeting will not be held prior to bid opening.

A **NON-MANDATORY PRE-BID** meeting will be held at the following place and time:

A **MANDATORY PRE-BID** meeting will be held at the following place and time:

All Vendors submitting a bid must attend the mandatory pre-bid meeting. Failure to attend the mandatory pre-bid meeting shall result in disqualification of the Vendor's bid. No one person attending the pre-bid meeting may represent more than one Vendor.

An attendance sheet provided at the pre-bid meeting shall serve as the official document verifying attendance. The State will not accept any other form of proof or documentation to verify attendance. Any person attending the pre-bid meeting on behalf of a Vendor must list on the attendance sheet his or her name and the name of the Vendor he or she is representing. Additionally, the person attending the pre-bid meeting should include the Vendor's E-Mail address, phone number, and Fax number on the attendance sheet. It is the Vendor's responsibility to locate the attendance sheet and provide the required

information. Failure to complete the attendance sheet as required may result in disqualification of Vendor's bid.

All Vendors should arrive prior to the starting time for the pre-bid. Vendors who arrive after the starting time but prior to the end of the pre-bid will be permitted to sign in, but are charged with knowing all matters discussed at the pre-bid.

Questions submitted at least five business days prior to a scheduled pre-bid will be discussed at the pre-bid meeting if possible. Any discussions or answers to questions at the pre-bid meeting are preliminary in nature and are non-binding. Official and binding answers to questions will be published in a written addendum to the Solicitation prior to bid opening.

4. **VENDOR QUESTION DEADLINE:** Vendors may submit questions relating to this Solicitation to the Purchasing Division. Questions must be submitted in writing. All questions must be submitted on or before the date listed below and to the address listed below in order to be considered. A written response will be published in a Solicitation addendum if a response is possible and appropriate. Non-written discussions, conversations, or questions and answers regarding this Solicitation are preliminary in nature and are non-binding.

Question Submission Deadline: May 29, 2013

Submit Questions to:

Connie Oswald

2019 Washington Street, East

P.O. Box 50130

Charleston, WV 25305

Fax: 304-558-3970

Email: Connie.S.Oswald@wv.gov

5. **VERBAL COMMUNICATION:** Any verbal communication between the Vendor and any State personnel is not binding, including that made at the mandatory pre-bid conference. Only information issued in writing and added to the Solicitation by an official written addendum by the Purchasing Division is binding.
6. **BID SUBMISSION:** All bids must be signed and delivered by the Vendor to the Purchasing Division at the address listed below on or before the date and time of the bid opening. Any bid received by the Purchasing Division staff is considered to be in the possession of the Purchasing Division and will not be returned for any reason. The bid delivery address is:

Department of Administration, Purchasing Division  
2019 Washington Street East  
P.O. Box 50130,  
Charleston, WV 25305-0130

The bid should contain the information listed below on the face of the envelope or the bid may not be considered:

SEALED BID  
 BUYER: \_\_\_\_\_  
 SOLICITATION NO.: \_\_\_\_\_  
 BID OPENING DATE: \_\_\_\_\_  
 BID OPENING TIME: \_\_\_\_\_  
 FAX NUMBER: \_\_\_\_\_

In the event that Vendor is responding to a request for proposal, the Vendor shall submit one original technical and one original cost proposal plus  convenience copies of each to the Purchasing Division at the address shown above. Additionally, the Vendor should identify the bid type as either a technical or cost proposal on the face of each bid envelope submitted in response to a request for proposal as follows:

BID TYPE:     Technical  
                   Cost

- 7. **BID OPENING:** Bids submitted in response to this Solicitation will be opened at the location identified below on the date and time listed below. Delivery of a bid after the bid opening date and time will result in bid disqualification. For purposes of this Solicitation, a bid is considered delivered when time stamped by the official Purchasing Division time clock.

**Bid Opening Date and Time:**

June 13, 2013 at 1:30 pm
--------------------------

**Bid Opening Location:**

Department of Administration, Purchasing Division  
 2019 Washington Street East  
 P.O. Box 50130,  
 Charleston, WV 25305-0130

- 8. **ADDENDUM ACKNOWLEDGEMENT:** Changes or revisions to this Solicitation will be made by an official written addendum issued by the Purchasing Division. Vendor should acknowledge receipt of all addenda issued with this Solicitation by completing an Addendum Acknowledgment Form, a copy of which is included herewith. Failure to acknowledge addenda may result in bid disqualification. The addendum acknowledgement should be submitted with the bid to expedite document processing.
- 9. **BID FORMATTING:** Vendor should type or electronically enter the information onto its bid to prevent errors in the evaluation. Failure to type or electronically enter the information may result in bid disqualification.

**GENERAL TERMS AND CONDITIONS:**

1. **CONTRACTUAL AGREEMENT:** Issuance of a Purchase Order signed by the Purchasing Division Director, or his designee, and approved as to form by the Attorney General's office constitutes acceptance of this Contract made by and between the State of West Virginia and the Vendor. Vendor's signature on its bid signifies Vendor's agreement to be bound by and accept the terms and conditions contained in this Contract.
  
2. **DEFINITIONS:** As used in this Solicitation / Contract, the following terms shall have the meanings attributed to them below. Additional definitions may be found in the specifications included with this Solicitation / Contract.
  - 2.1 "Agency" or "Agencies" means the agency, board, commission, or other entity of the State of West Virginia that is identified on the first page of the Solicitation or any other public entity seeking to procure goods or services under this Contract.
  - 2.2 "Contract" means the binding agreement that is entered into between the State and the Vendor to provide the goods and services requested in the Solicitation.
  - 2.3 "Director" means the Director of the West Virginia Department of Administration, Purchasing Division.
  - 2.4 "Purchasing Division" means the West Virginia Department of Administration, Purchasing Division.
  - 2.5 "Purchase Order" means the document signed by the Agency and the Purchasing Division, and approved as to form by the Attorney General, that identifies the Vendor as the successful bidder and Contract holder.
  - 2.6 "Solicitation" means the official solicitation published by the Purchasing Division and identified by number on the first page thereof.
  - 2.7 "State" means the State of West Virginia and/or any of its agencies, commissions, boards, etc. as context requires.
  - 2.8 "Vendor" or "Vendors" means any entity submitting a bid in response to the Solicitation, the entity that has been selected as the lowest responsible bidder, or the entity that has been awarded the Contract as context requires.

3. **CONTRACT TERM; RENEWAL; EXTENSION:** The term of this Contract shall be determined in accordance with the category that has been identified as applicable to this Contract below:

**Term Contract**

**Initial Contract Term:** This Contract becomes effective on   
 Upon Award  
 and extends for a period of  year(s).

**Renewal Term:** This Contract may be renewed upon the mutual written consent of the Agency, and the Vendor, with approval of the Purchasing Division and the Attorney General's office (Attorney General approval is as to form only). Any request for renewal must be submitted to the Purchasing Division Director thirty (30) days prior to the expiration date of the initial contract term or appropriate renewal term. A Contract renewal shall be in accordance with the terms and conditions of the original contract. Renewal of this Contract is limited to  successive one (1) year periods. Automatic renewal of this Contract is prohibited. Notwithstanding the foregoing, Purchasing Division approval is not required on agency delegated or exempt purchases. Attorney General approval may be required for vendor terms and conditions.

**Reasonable Time Extension:** At the sole discretion of the Purchasing Division Director, and with approval from the Attorney General's office (Attorney General approval is as to form only), this Contract may be extended for a reasonable time after the initial Contract term or after any renewal term as may be necessary to obtain a new contract or renew this Contract. Any reasonable time extension shall not exceed twelve (12) months. Vendor may avoid a reasonable time extension by providing the Purchasing Division Director with written notice of Vendor's desire to terminate this Contract 30 days prior to the expiration of the then current term. During any reasonable time extension period, the Vendor may terminate this Contract for any reason upon giving the Purchasing Division Director 30 days written notice. Automatic extension of this Contract is prohibited. Notwithstanding the foregoing, Purchasing Division approval is not required on agency delegated or exempt purchases, but Attorney General approval may be required.

- Fixed Period Contract:** This Contract becomes effective upon Vendor's receipt of the notice to proceed and must be completed within  days.
- One Time Purchase:** The term of this Contract shall run from the issuance of the Purchase Order until all of the goods contracted for have been delivered, but in no event shall this Contract extend for more than one fiscal year.
- Other:** See attached.

4. **NOTICE TO PROCEED:** Vendor shall begin performance of this Contract immediately upon receiving notice to proceed unless otherwise instructed by the Agency. Unless otherwise specified, the fully executed Purchase Order will be considered notice to proceed
5. **QUANTITIES:** The quantities required under this Contract shall be determined in accordance with the category that has been identified as applicable to this Contract below.
- Open End Contract:** Quantities listed in this Solicitation are approximations only, based on estimates supplied by the Agency. It is understood and agreed that the Contract shall cover the quantities actually ordered for delivery during the term of the Contract, whether more or less than the quantities shown.
  - Service:** The scope of the service to be provided will be more clearly defined in the specifications included herewith.
  - Combined Service and Goods:** The scope of the service and deliverable goods to be provided will be more clearly defined in the specifications included herewith.
  - One Time Purchase:** This Contract is for the purchase of a set quantity of goods that are identified in the specifications included herewith. Once those items have been delivered, no additional goods may be procured under this Contract without an appropriate change order approved by the Vendor, Agency, Purchasing Division, and Attorney General's office.
6. **PRICING:** The pricing set forth herein is firm for the life of the Contract, unless specified elsewhere within this Solicitation/Contract by the State. A Vendor's inclusion of price adjustment provisions in its bid, without an express authorization from the State in the Solicitation to do so, may result in bid disqualification.
7. **EMERGENCY PURCHASES:** The Purchasing Division Director may authorize the Agency to purchase goods or services in the open market that Vendor would otherwise provide under this Contract if those goods or services are for immediate or expedited delivery in an emergency. Emergencies shall include, but are not limited to, delays in transportation or an unanticipated increase in the volume of work. An emergency purchase in the open market, approved by the Purchasing Division Director, shall not constitute of breach of this Contract and shall not entitle the Vendor to any form of compensation or damages. This provision does not excuse the State from fulfilling its obligations under a One Time Purchase contract.
8. **REQUIRED DOCUMENTS:** All of the items checked below must be provided to the Purchasing Division by the Vendor as specified below.
- BID BOND:** All Vendors shall furnish a bid bond in the amount of five percent (5%) of the total amount of the bid protecting the State of West Virginia. The bid bond must be submitted with the bid.

**PERFORMANCE BOND:** The apparent successful Vendor shall provide a performance bond in the amount of . The performance bond must be issued and received by the Purchasing Division prior to Contract award. On construction contracts, the performance bond must be 100% of the Contract value.

**LABOR/MATERIAL PAYMENT BOND:** The apparent successful Vendor shall provide a labor/material payment bond in the amount of 100% of the Contract value. The labor/material payment bond must be issued and delivered to the Purchasing Division prior to Contract award.

In lieu of the Bid Bond, Performance Bond, and Labor/Material Payment Bond, the Vendor may provide certified checks, cashier's checks, or irrevocable letters of credit. Any certified check, cashier's check, or irrevocable letter of credit provided in lieu of a bond must be of the same amount and delivered on the same schedule as the bond it replaces. A letter of credit submitted in lieu of a performance and labor/material payment bond will only be allowed for projects under \$100,000. Personal or business checks are not acceptable.

**MAINTENANCE BOND:** The apparent successful Vendor shall provide a two (2) year maintenance bond covering the roofing system. The maintenance bond must be issued and delivered to the Purchasing Division prior to Contract award.

**WORKERS' COMPENSATION INSURANCE:** The apparent successful Vendor shall have appropriate workers' compensation insurance and shall provide proof thereof upon request.

**INSURANCE:** The apparent successful Vendor shall furnish proof of the following insurance prior to Contract award:

**Commercial General Liability Insurance:**  
 \$1,000,000.00 minimum or more.

**Builders Risk Insurance:** builders risk – all risk insurance in an amount equal to 100% of the amount of the Contract.

- 
- 
- 
- 
-



The apparent successful Vendor shall also furnish proof of any additional insurance requirements contained in the specifications prior to Contract award regardless of whether or not that insurance requirement is listed above.

[ ] **LICENSE(S) / CERTIFICATIONS / PERMITS:** In addition to anything required under the Section entitled Licensing, of the General Terms and Conditions, the apparent successful Vendor shall furnish proof of the following licenses, certifications, and/or permits prior to Contract award, in a form acceptable to the Purchasing Division.

[ ]	
[ ]	
[ ]	
[ ]	

The apparent successful Vendor shall also furnish proof of any additional licenses or certifications contained in the specifications prior to Contract award regardless of whether or not that requirement is listed above.

**9. LITIGATION BOND:** The Director reserves the right to require any Vendor that files a protest of an award to submit a litigation bond in the amount equal to one percent of the lowest bid submitted or \$5,000, whichever is greater. The entire amount of the bond shall be forfeited if the hearing officer determines that the protest was filed for frivolous or improper purpose, including but not limited to, the purpose of harassing, causing unnecessary delay, or needless expense for the Agency. All litigation bonds shall be made payable to the Purchasing Division. In lieu of a bond, the protester may submit a cashier's check or certified check payable to the Purchasing Division. Cashier's or certified checks will be deposited with and held by the State Treasurer's office. If it is determined that the protest has not been filed for frivolous or improper purpose, the bond or deposit shall be returned in its entirety.

**10. ALTERNATES:** Any model, brand, or specification listed herein establishes the acceptable level of quality only and is not intended to reflect a preference for, or in any way favor, a particular brand or vendor. Vendors may bid alternates to a listed model or brand provided that the alternate is at least equal to the model or brand and complies with the required specifications. The equality of any alternate being bid shall be determined by the State at its sole discretion. Any Vendor bidding an alternate model or brand should clearly identify the alternate items in its bid and should include manufacturer's specifications, industry literature, and/or any other relevant documentation demonstrating the equality of the alternate items. Failure to provide information for alternate items may be grounds for rejection of a Vendor's bid.

**11. EXCEPTIONS AND CLARIFICATIONS:** The Solicitation contains the specifications that shall form the basis of a contractual agreement. Vendor shall clearly mark any exceptions, clarifications, or

other proposed modifications in its bid. Exceptions to, clarifications of, or modifications of a requirement or term and condition of the Solicitation may result in bid disqualification.

**12. LIQUIDATED DAMAGES:** Vendor shall pay liquidated damages in the amount

	for	

This clause shall in no way be considered exclusive and shall not limit the State or Agency's right to pursue any other available remedy.

- 13. ACCEPTANCE/REJECTION:** The State may accept or reject any bid in whole, or in part. Vendor's signature on its bid signifies acceptance of the terms and conditions contained in the Solicitation and Vendor agrees to be bound by the terms of the Contract, as reflected in the Purchase Order, upon receipt.
- 14. REGISTRATION:** Prior to Contract award, the apparent successful Vendor must be properly registered with the West Virginia Purchasing Division and must have paid the \$125 fee if applicable.
- 15. COMMUNICATION LIMITATIONS:** In accordance with West Virginia Code of State Rules §148-1-6.6, communication with the State of West Virginia or any of its employees regarding this Solicitation during the solicitation, bid, evaluation or award periods, except through the Purchasing Division, is strictly prohibited without prior Purchasing Division approval. Purchasing Division approval for such communication is implied for all agency delegated and exempt purchases.
- 16. FUNDING:** This Contract shall continue for the term stated herein, contingent upon funds being appropriated by the Legislature or otherwise being made available. In the event funds are not appropriated or otherwise made available, this Contract becomes void and of no effect beginning on July 1 of the fiscal year for which funding has not been appropriated or otherwise made available.
- 17. PAYMENT:** Payment in advance is prohibited under this Contract. Payment may only be made after the delivery and acceptance of goods or services. The Vendor shall submit invoices, in arrears, to the Agency at the address on the face of the purchase order labeled "Invoice To."
- 18. UNIT PRICE:** Unit prices shall prevail in cases of a discrepancy in the Vendor's bid.
- 19. DELIVERY:** All quotations are considered freight on board destination ("F.O.B. destination") unless alternate shipping terms are clearly identified in the bid. Vendor's listing of shipping terms that contradict the shipping terms expressly required by this Solicitation may result in bid disqualification.
- 20. INTEREST:** Interest attributable to late payment will only be permitted if authorized by the West Virginia Code. Presently, there is no provision in the law for interest on late payments.
- 21. PREFERENCE:** Vendor Preference may only be granted upon written request and only in accordance with the West Virginia Code § 5A-3-37 and the West Virginia Code of State Rules. A Resident Vendor Certification form has been attached hereto to allow Vendor to apply for the preference. Vendor's

failure to submit the Resident Vendor Certification form with its bid will result in denial of Vendor Preference. Vendor Preference does not apply to construction projects.

22. **SMALL, WOMEN-OWNED, OR MINORITY-OWNED BUSINESSES:** For any solicitations publicly advertised for bid on or after July 1, 2012, in accordance with West Virginia Code §5A-3-37(a)(7) and W. Va. CSR § 148-22-9, any non-resident vendor certified as a small, women-owned, or minority-owned business under W. Va. CSR § 148-22-9 shall be provided the same preference made available to any resident vendor. Any non-resident small, women-owned, or minority-owned business must identify itself as such in writing, must submit that writing to the Purchasing Division with its bid, and must be properly certified under W. Va. CSR § 148-22-9 prior to submission of its bid to receive the preferences made available to resident vendors. Preference for a non-resident small, women-owned, or minority owned business shall be applied in accordance with W. Va. CSR § 148-22-9.
23. **TAXES:** The Vendor shall pay any applicable sales, use, personal property or any other taxes arising out of this Contract and the transactions contemplated thereby. The State of West Virginia is exempt from federal and state taxes and will not pay or reimburse such taxes.
24. **CANCELLATION:** The Purchasing Division Director reserves the right to cancel this Contract immediately upon written notice to the vendor if the materials or workmanship supplied do not conform to the specifications contained in the Contract. The Purchasing Division Director may cancel any purchase or Contract upon 30 days written notice to the Vendor in accordance with West Virginia Code of State Rules § 148-1-7.16.2.
25. **WAIVER OF MINOR IRREGULARITIES:** The Director reserves the right to waive minor irregularities in bids or specifications in accordance with West Virginia Code of State Rules § 148-1-4.6.
26. **TIME:** Time is of the essence with regard to all matters of time and performance in this Contract.
27. **APPLICABLE LAW:** This Contract is governed by and interpreted under West Virginia law without giving effect to its choice of law principles. Any information provided in specification manuals, or any other source, verbal or written, which contradicts or violates the West Virginia Constitution, West Virginia Code or West Virginia Code of State Rules is void and of no effect.
28. **COMPLIANCE:** Vendor shall comply with all applicable federal, state, and local laws, regulations and ordinances. By submitting a bid, Vendors acknowledge that they have reviewed, understand, and will comply with all applicable law.
29. **PREVAILING WAGE:** On any contract for the construction of a public improvement, Vendor and any subcontractors utilized by Vendor shall pay a rate or rates of wages which shall not be less than the fair minimum rate or rates of wages (prevailing wage), as established by the West Virginia Division of Labor under West Virginia Code §§ 21-5A-1 et seq. and available at <http://www.sos.wv.gov/administrative-law/wagerates/Pages/default.aspx>. Vendor shall be responsible for ensuring compliance with prevailing wage requirements and determining when prevailing wage

requirements are applicable. The required contract provisions contained in West Virginia Code of State Rules § 42-7-3 are specifically incorporated herein by reference.

30. **ARBITRATION:** Any references made to arbitration contained in this Contract, Vendor's bid, or in any American Institute of Architects documents pertaining to this Contract are hereby deleted, void, and of no effect.
31. **MODIFICATIONS:** This writing is the parties' final expression of intent. Notwithstanding anything contained in this Contract to the contrary, no modification of this Contract shall be binding without mutual written consent of the Agency, and the Vendor, with approval of the Purchasing Division and the Attorney General's office (Attorney General approval is as to form only). **No Change shall be implemented by the Vendor until such time as the Vendor receives an approved written change order from the Purchasing Division.**
32. **WAIVER:** The failure of either party to insist upon a strict performance of any of the terms or provision of this Contract, or to exercise any option, right, or remedy herein contained, shall not be construed as a waiver or a relinquishment for the future of such term, provision, option, right, or remedy, but the same shall continue in full force and effect. Any waiver must be expressly stated in writing and signed by the waiving party.
33. **SUBSEQUENT FORMS:** The terms and conditions contained in this Contract shall supersede any and all subsequent terms and conditions which may appear on any form documents submitted by Vendor to the Agency or Purchasing Division such as price lists, order forms, invoices, sales agreements, or maintenance agreements, and includes internet websites or other electronic documents. Acceptance or use of Vendor's forms does not constitute acceptance of the terms and conditions contained thereon.
34. **ASSIGNMENT:** Neither this Contract nor any monies due, or to become due hereunder, may be assigned by the Vendor without the express written consent of the Agency, the Purchasing Division, the Attorney General's office (as to form only), and any other government agency or office that may be required to approve such assignments. Notwithstanding the foregoing, Purchasing Division approval may or may not be required on certain agency delegated or exempt purchases.
35. **WARRANTY:** The Vendor expressly warrants that the goods and/or services covered by this Contract will: (a) conform to the specifications, drawings, samples, or other description furnished or specified by the Agency; (b) be merchantable and fit for the purpose intended; and (c) be free from defect in material and workmanship.
36. **STATE EMPLOYEES:** State employees are not permitted to utilize this Contract for personal use and the Vendor is prohibited from permitting or facilitating the same.
37. **BANKRUPTCY:** In the event the Vendor files for bankruptcy protection, the State of West Virginia may deem this Contract null and void, and terminate this Contract without notice.

- 38. HIPAA BUSINESS ASSOCIATE ADDENDUM:** The West Virginia State Government HIPAA Business Associate Addendum (BAA), approved by the Attorney General, is available online at <http://www.state.wv.us/admin/purchase/vrc/hipaa.html> and is hereby made part of the agreement provided that the Agency meets the definition of a Covered entity (45 CFR §160.103) and will be disclosing Protected Health Information (45 CFR §160.103) to the Vendor. Additionally, the HIPAA Privacy, Security, Enforcement & Breach Notification Final Omnibus Rule was published on January 25, 2013. It may be viewed online at <http://www.gpo.gov/fdsys/pkg/FR-2013-01-25/pdf/2013-01073.pdf>. Any organization, that qualifies as the Agency's Business Associate, is expected to be in compliance with this Final Rule. For those Business Associates entering into contracts with a HIPAA Covered State Agency between January 25, 2013 and the release of the 2013 WV State Agency Business Associate Agreement, or September 23, 2013 (whichever is earlier), be advised that you will be required to comply with the 2013 WV State Agency Business Associate Agreement. For those Business Associates with contracts with a HIPAA Covered State Agency executed prior to January 25, 2013, be advised that upon renewal or modification, you will be required to comply with the 2013 WV State Agency Business Associate Agreement no later than September 22, 2014.
- 39. CONFIDENTIALITY:** The Vendor agrees that it will not disclose to anyone, directly or indirectly, any such personally identifiable information or other confidential information gained from the Agency, unless the individual who is the subject of the information consents to the disclosure in writing or the disclosure is made pursuant to the Agency's policies, procedures, and rules. Vendor further agrees to comply with the Confidentiality Policies and Information Security Accountability Requirements, set forth in <http://www.state.wv.us/admin/purchase/privacy/default.html>.
- 40. DISCLOSURE:** Vendor's response to the Solicitation and the resulting Contract are considered public documents and will be disclosed to the public in accordance with the laws, rules, and policies governing the West Virginia Purchasing Division. Those laws include, but are not limited to, the Freedom of Information Act found in West Virginia Code § 29B-1-1 et seq.

If a Vendor considers any part of its bid to be exempt from public disclosure, Vendor must so indicate by specifically identifying the exempt information, identifying the exemption that applies, providing a detailed justification for the exemption, segregating the exempt information from the general bid information, and submitting the exempt information as part of its bid but in a segregated and clearly identifiable format. Failure to comply with the foregoing requirements will result in public disclosure of the Vendor's bid without further notice. A Vendor's act of marking all or nearly all of its bid as exempt is not sufficient to avoid disclosure and WILL NOT BE HONORED. Vendor's act of marking a bid or any part thereof as "confidential" or "proprietary" is not sufficient to avoid disclosure and WILL NOT BE HONORED. In addition, a legend or other statement indicating that all or substantially all of the bid is exempt from disclosure is not sufficient to avoid disclosure and WILL NOT BE HONORED. Vendor will be required to defend any claimed exemption for nondisclosure in the event of an administrative or judicial challenge to the State's nondisclosure. Vendor must indemnify the State for any costs incurred related to any exemptions claimed by Vendor. Any questions regarding the applicability of the various public records laws should be addressed to your own legal counsel prior to bid submission.

- 41. LICENSING:** In accordance with West Virginia Code of State Rules §148-1-6.1.7, Vendor must be licensed and in good standing in accordance with any and all state and local laws and requirements by any state or local agency of West Virginia, including, but not limited to, the West Virginia Secretary of State's Office, the West Virginia Tax Department, West Virginia Insurance Commission, or any other state agency or political subdivision. Upon request, the Vendor must provide all necessary releases to obtain information to enable the Purchasing Division Director or the Agency to verify that the Vendor is licensed and in good standing with the above entities.
- 42. ANTITRUST:** In submitting a bid to, signing a contract with, or accepting a Purchase Order from any agency of the State of West Virginia, the Vendor agrees to convey, sell, assign, or transfer to the State of West Virginia all rights, title, and interest in and to all causes of action it may now or hereafter acquire under the antitrust laws of the United States and the State of West Virginia for price fixing and/or unreasonable restraints of trade relating to the particular commodities or services purchased or acquired by the State of West Virginia. Such assignment shall be made and become effective at the time the purchasing agency tenders the initial payment to Vendor.
- 43. VENDOR CERTIFICATIONS:** By signing its bid or entering into this Contract, Vendor certifies (1) that its bid was made without prior understanding, agreement, or connection with any corporation, firm, limited liability company, partnership, person or entity submitting a bid for the same material, supplies, equipment or services; (2) that its bid is in all respects fair and without collusion or fraud; (3) that this Contract is accepted or entered into without any prior understanding, agreement, or connection to any other entity that could be considered a violation of law; and (4) that it has reviewed this RFQ in its entirety; understands the requirements, terms and conditions, and other information contained herein. Vendor's signature on its bid also affirms that neither it nor its representatives have any interest, nor shall acquire any interest, direct or indirect, which would compromise the performance of its services hereunder. Any such interests shall be promptly presented in detail to the Agency.

The individual signing this bid on behalf of Vendor certifies that he or she is authorized by the Vendor to execute this bid or any documents related thereto on Vendor's behalf; that he or she is authorized to bind the Vendor in a contractual relationship; and that, to the best of his or her knowledge, the Vendor has properly registered with any State agency that may require registration.

- 44. PURCHASING CARD ACCEPTANCE:** The State of West Virginia currently utilizes a Purchasing Card program, administered under contract by a banking institution, to process payment for goods and services. The Vendor must accept the State of West Virginia's Purchasing Card for payment of all orders under this Contract unless the box below is checked.

Vendor is not required to accept the State of West Virginia's Purchasing Card as payment for all goods and services.

- 45. VENDOR RELATIONSHIP:** The relationship of the Vendor to the State shall be that of an independent contractor and no principal-agent relationship or employer-employee relationship is contemplated or created by this Contract. The Vendor as an independent contractor is solely liable for the acts and omissions of its employees and agents. Vendor shall be responsible for selecting,

supervising, and compensating any and all individuals employed pursuant to the terms of this Solicitation and resulting contract. Neither the Vendor, nor any employees or subcontractors of the Vendor, shall be deemed to be employees of the State for any purpose whatsoever. Vendor shall be exclusively responsible for payment of employees and contractors for all wages and salaries, taxes, withholding payments, penalties, fees, fringe benefits, professional liability insurance premiums, contributions to insurance and pension, or other deferred compensation plans, including but not limited to, Workers' Compensation and Social Security obligations, licensing fees, *etc.* and the filing of all necessary documents, forms and returns pertinent to all of the foregoing. Vendor shall hold harmless the State, and shall provide the State and Agency with a defense against any and all claims including, but not limited to, the foregoing payments, withholdings, contributions, taxes, Social Security taxes, and employer income tax returns.

- 46. INDEMNIFICATION:** The Vendor agrees to indemnify, defend, and hold harmless the State and the Agency, their officers, and employees from and against: (1) Any claims or losses for services rendered by any subcontractor, person, or firm performing or supplying services, materials, or supplies in connection with the performance of the Contract; (2) Any claims or losses resulting to any person or entity injured or damaged by the Vendor, its officers, employees, or subcontractors by the publication, translation, reproduction, delivery, performance, use, or disposition of any data used under the Contract in a manner not authorized by the Contract, or by Federal or State statutes or regulations; and (3) Any failure of the Vendor, its officers, employees, or subcontractors to observe State and Federal laws including, but not limited to, labor and wage and hour laws.
- 47. PURCHASING AFFIDAVIT:** In accordance with West Virginia Code § 5A-3-10a, all Vendors are required to sign, notarize, and submit the Purchasing Affidavit stating that neither the Vendor nor a related party owe a debt to the State in excess of \$1,000. The affidavit must be submitted prior to award, but should be submitted with the Vendor's bid. A copy of the Purchasing Affidavit is included herewith.
- 48. ADDITIONAL AGENCY AND LOCAL GOVERNMENT USE:** This Contract may be utilized by and extends to other agencies, spending units, and political subdivisions of the State of West Virginia; county, municipal, and other local government bodies; and school districts ("Other Government Entities"). This Contract shall be extended to the aforementioned Other Government Entities on the same prices, terms, and conditions as those offered and agreed to in this Contract. If the Vendor does not wish to extend the prices, terms, and conditions of its bid and subsequent contract to the Other Government Entities, the Vendor must clearly indicate such refusal in its bid. A refusal to extend this Contract to the Other Government Entities shall not impact or influence the award of this Contract in any manner.
- 49. CONFLICT OF INTEREST:** Vendor, its officers or members or employees, shall not presently have or acquire any interest, direct or indirect, which would conflict with or compromise the performance of its obligations hereunder. Vendor shall periodically inquire of its officers, members and employees to ensure that a conflict of interest does not arise. Any conflict of interest discovered shall be promptly presented in detail to the Agency.

**50. REPORTS:** Vendor shall provide the Agency and/or the Purchasing Division with the following reports identified by a checked box below:

- Such reports as the Agency and/or the Purchasing Division may request. Requested reports may include, but are not limited to, quantities purchased, agencies utilizing the contract, total contract expenditures by agency, etc.
- Quarterly reports detailing the total quantity of purchases in units and dollars, along with a listing of purchases by agency. Quarterly reports should be delivered to the Purchasing Division via email at [purchasing.requisitions@wv.gov](mailto:purchasing.requisitions@wv.gov).

**51. BACKGROUND CHECK:** In accordance with W. Va. Code § 15-2D-3, the Director of the Division of Protective Services shall require any service provider whose employees are regularly employed on the grounds or in the buildings of the Capitol complex or who have access to sensitive or critical information to submit to a fingerprint-based state and federal background inquiry through the state repository. The service provider is responsible for any costs associated with the fingerprint-based state and federal background inquiry.

After the contract for such services has been approved, but before any such employees are permitted to be on the grounds or in the buildings of the Capitol complex or have access to sensitive or critical information, the service provider shall submit a list of all persons who will be physically present and working at the Capitol complex to the Director of the Division of Protective Services for purposes of verifying compliance with this provision.

The State reserves the right to prohibit a service provider's employees from accessing sensitive or critical information or to be present at the Capitol complex based upon results addressed from a criminal background check.

Service providers should contact the West Virginia Division of Protective Services by phone at (304) 558-9911 for more information.

**52. PREFERENCE FOR USE OF DOMESTIC STEEL PRODUCTS:** Except when authorized by the Director of the Purchasing Division pursuant to W. Va. Code § 5A-3-56, no contractor may use or supply steel products for a State Contract Project other than those steel products made in the United States. A contractor who uses steel products in violation of this section may be subject to civil penalties pursuant to W. Va. Code § 5A-3-56. As used in this section:

- a. "State Contract Project" means any erection or construction of, or any addition to, alteration of or other improvement to any building or structure, including, but not limited to, roads or highways, or the installation of any heating or cooling or ventilating plants or other equipment, or the supply of and materials for such projects, pursuant to a contract with the State of West Virginia for which bids were solicited on or after June 6, 2001.
- b. "Steel Products" means products rolled, formed, shaped, drawn, extruded, forged, cast, fabricated or otherwise similarly processed, or processed by a combination of two or more or



such operations, from steel made by the open hearth, basic oxygen, electric furnace, Bessemer or other steel making process.

The Purchasing Division Director may, in writing, authorize the use of foreign steel products if:

- a. The cost for each contract item used does not exceed one tenth of one percent (.1%) of the total contract cost or two thousand five hundred dollars (\$2,500.00), whichever is greater. For the purposes of this section, the cost is the value of the steel product as delivered to the project; or
- b. The Director of the Purchasing Division determines that specified steel materials are not produced in the United States in sufficient quantity or otherwise are not reasonably available to meet contract requirements.

**53. PREFERENCE FOR USE OF DOMESTIC ALUMINUM, GLASS, AND STEEL:** In Accordance with W. Va. Code § 5-19-1 et seq., and W. Va. CSR § 148-10-1 et seq., for every contract or subcontract, subject to the limitations contained herein, for the construction, reconstruction, alteration, repair, improvement or maintenance of public works or for the purchase of any item of machinery or equipment to be used at sites of public works, only domestic aluminum, glass or steel products shall be supplied unless the spending officer determines, in writing, after the receipt of offers or bids, (1) that the cost of domestic aluminum, glass or steel products is unreasonable or inconsistent with the public interest of the State of West Virginia, (2) that domestic aluminum, glass or steel products are not produced in sufficient quantities to meet the contract requirements, or (3) the available domestic aluminum, glass, or steel do not meet the contract specifications. This provision only applies to public works contracts awarded in an amount more than fifty thousand dollars (\$50,000) or public works contracts that require more than ten thousand pounds of steel products.

The cost of domestic aluminum, glass, or steel products may be unreasonable if the cost is more than twenty percent (20%) of the bid or offered price for foreign made aluminum, glass, or steel products. If the domestic aluminum, glass or steel products to be supplied or produced in a "substantial labor surplus area", as defined by the United States Department of Labor, the cost of domestic aluminum, glass, or steel products may be unreasonable if the cost is more than thirty percent (30%) of the bid or offered price for foreign made aluminum, glass, or steel products.

This preference shall be applied to an item of machinery or equipment, as indicated above, when the item is a single unit of equipment or machinery manufactured primarily of aluminum, glass or steel, is part of a public works contract and has the sole purpose or of being a permanent part of a single public works project. This provision does not apply to equipment or machinery purchased by a spending unit for use by that spending unit and not as part of a single public works project.

All bids and offers including domestic aluminum, glass or steel products that exceed bid or offer prices including foreign aluminum, glass or steel products after application of the preferences provided in this provision may be reduced to a price equal to or lower than the lowest bid or offer price for foreign aluminum, glass or steel products plus the applicable preference. If the reduced bid or offer prices are made in writing and supersede the prior bid or offer prices, all bids or offers, including the reduced bid or offer prices, will be reevaluated in accordance with this rule.

---

**SPECIFICATIONS**

**PURPOSE AND SCOPE:** The West Virginia Purchasing Division is soliciting bids on behalf of the West Virginia Department of Education to establish a contract for Internet filtering and reporting solution that consists of software, licensing, software upgrades/updates, database updates and technical support. The vendor must include servers or appliances and associated costs in the quotation if the vendor's software cannot meet the requirements of this RFQ when installed on WVDE owned servers which are described in Section I – Current Environment.

**Section I – Current Environment**

Approximately 750 public schools in 57 school districts of West Virginia are connected with a privately addressed TCP/IP statewide network. The network uses the private Class A range of 10.0.0.0 IPv4 addresses. The POPs are equipped with Cisco 6513 switches that contain Cisco router and Cisco PIX firewall modules that route and translate the private IP addresses to our Class B 168.216.0.0 public network IP addresses. The Internet filtering **shall** be done at the two POPs where the K-12 network is routed to the ISP. The POPs are located in the WVNET facilities in Morgantown, WV and in the shared facilities vault at Building 6 of the State Capitol Complex at Charleston, WV. Each one of the two POPs connects approximately 100,000 unique computers to the Internet with 10 gigabits/second of bandwidth. There are approximately 260,000 students and 20,000 staff who utilize the K-12 network daily. These users are fairly evenly divided between the two POPs.

**POP Site #1 Charleston, WV, is equipped with the following WVDE owned servers on which the filtering solution may be installed.**

5 (five) Cisco UCS C200 M2 servers with following specifications:  
Dual 2.40 GHz XEON E5620 Processor with 12 MB L3 cache, 16 GB DDR3 dimm, dual 300 GB SAS 15k drives in mirrored RAID, dual onboard gigabit copper Ethernet NICs.

1 (one) Cisco UCS C200 M2 server with following specifications:  
Dual 2.40 GHz XEON E5620 Processor with 12 MB L3 cache, 16 GB DDR3 dimm, 4 (four) 2TB SAS 7.2k drives in RAID 5, dual onboard gigabit copper Ethernet NICs.

**POP Site #2 Morgantown, WV, is equipped with the following WVDE owned servers on which the filtering solution may be installed:**

3 (three) Cisco UCS C200 M2 servers with following specifications:  
Dual 2.40 GHz XEON E5620 Processor with 12 MB L3 cache, 16 GB DDR3 dimm, dual 300 GB SAS 15k drives in mirrored RAID, dual onboard gigabit copper Ethernet NICs.

If the server specifications and/or the number of servers listed above are not capable of fully supporting the vendor's filtering solution, the vendor **must** include all appropriate servers or appliances and associated costs in the response to this RFQ.

The total number of computers to be filtered is approximately 200,000 computers. Approximately 280,000 users utilize the K-12 network on a daily basis. The Internet filtering **must** occur at the points in the network after which the K-12 core routers consolidate Internet traffic but before the firewall dynamically changes the private IP addresses to public IP addresses as shown in the diagram on attachment A. The filtering servers and reporting servers **must** operate within the scope of the K-12 private network so that filtering control and reporting will reflect the private IP addresses of the client computers. In the event that portable computers are connected to residential, public, or other networks, an option **must** be available to provide continued filtering of Internet web sites. No caching appliances are currently in use; however the Internet filtering solution **must** support the option for the WVDE to install caching appliances.

The quoted solution **must** be designed to accommodate peak usage at each of the two POP sites. Peak usage is defined as 100,000 computers, 140,000 users, and 10Gbps of bandwidth to the Internet at each POP site.

1. **DEFINITIONS:** The terms listed below shall have the meanings assigned to them below. Additional definitions can be found in section 2 of the General Terms and Conditions.
  - 1.1 **“Contract Item” or “Contract Items”** means the list of items identified in Section 3, Subsection 1 below.
  - 1.2 **“Filtering solution”** is used to refer to all vendor provided software and hardware used to perform Internet filtering and reporting functions, including but not limited to application software, operating system and database software.
  - 1.3 **“Pricing Pages”** means the schedule of prices, estimated order quantity, and totals attached hereto as Exhibit A and used to evaluate the RFQ.
  - 1.4 **“Server” and “Servers”** are used to refer to the hardware or appliances on which any component of the filtering solution is installed.
  - 1.5 **“RFQ”** means the official request for quotation published by the Purchasing Division and identified as EDD392953.

---

**2. GENERAL REQUIREMENTS:**

- 2.1 Contract Items and Mandatory Requirements:** Vendor shall provide Agency with the Contract Items listed below on an open-end and continuing basis. Contract Items must meet or exceed the mandatory requirements as shown below.

The products and services that are bid **must** be capable of providing a level of service appropriate for Internet Service Provider (ISP) facilities with 10 gigabits of Internet bandwidth. School based or district based filtering solutions are not an acceptable response to this RFQ.

The WVDE currently has two independent Internet connections for the K-12 public schools. Internet filtering solutions **must** be installed at both Points of Presence (POP). Because of the diverse needs of schools, the WVDE **must** have selective filtering levels and capabilities for delegated administration of tailored filtering policies or profiles for different subnets. Updates to the filtering solution **must** be provided at least once each day to ensure that the filtering database is up-to-date using multiple methods and resources for the review of content on Internet sites. The Internet filtering **must** meet the requirements of the E-rate program (refer to <http://www.usac.org/sl/>) and the West Virginia Board of Education Policy 2460 that is available online at <http://wvde.state.wv.us/policies/policy.php?p=2460&alt=1>. Information relevant to the Children's Internet Protection Act (CIPA) and the Federal requirement to implement Internet filtering is detailed at the URL <http://www.fcc.gov/cgb/consumerfacts/cipa.html>. The Children's Online Privacy Protection Act (COPPA) **must** not be violated by any requirements of the filtering solution to collect personal information about students. Refer to <http://www.ftc.gov/ogc/coppa1.htm> for information about COPPA.

**Section I – Current Environment**

Approximately 750 public schools in 57 school districts of West Virginia are connected with a privately addressed TCP/IP statewide network. The network uses the private Class A range of 10.0.0.0 IPv4 addresses. The POPs are equipped with Cisco 6513 switches that contain Cisco router and Cisco PIX firewall modules that route and translate the private IP addresses to our Class B 168.216.0.0 public network IP addresses. The Internet filtering **shall** be done at the two POPs where the K-12 network is routed to the ISP. The POPs are located in the WVNET facilities in Morgantown, WV and in the shared facilities vault at Building 6 of the State Capitol Complex at Charleston, WV. Each one of the two POPs connects approximately 100,000 unique computers to the Internet with 10 gigabits/second of bandwidth. There are approximately 260,000 students and 20,000 staff who utilize the K-12 network daily. These users are fairly evenly divided between the two POPs.

**POP Site #1 Charleston, WV, is equipped with the following WVDE owned servers on which the filtering solution may be installed.**

5 (five) Cisco UCS C200 M2 servers with following specifications:  
Dual 2.40 GHz XEON E5620 Processor with 12 MB L3 cache, 16 GB DDR3 dimm, dual 300 GB SAS 15k drives in mirrored RAID, dual onboard gigabit copper Ethernet NICs.

1 (one) Cisco UCS C200 M2 server with following specifications:  
Dual 2.40 GHz XEON E5620 Processor with 12 MB L3 cache, 16 GB DDR3 dimm, 4 (four) 2TB SAS 7.2k drives in RAID 5, dual onboard gigabit copper Ethernet NICs.

**POP Site #2 Morgantown, WV, is equipped with the following WVDE owned servers on which the filtering solution may be installed:**

3 (three) Cisco UCS C200 M2 servers with following specifications:  
Dual 2.40 GHz XEON E5620 Processor with 12 MB L3 cache, 16 GB DDR3 dimm, dual 300 GB SAS 15k drives in mirrored RAID, dual onboard gigabit copper Ethernet NICs.

If the server specifications and/or the number of servers listed above are not capable of fully supporting the vendor's filtering solution, the vendor **must** include all appropriate servers or appliances and associated costs in the response to this RFQ.

The total number of computers to be filtered is approximately 200,000 computers. Approximately 280,000 users utilize the K-12 network on a daily basis. The Internet filtering **must** occur at the points in the network after which the K-12 core routers consolidate Internet traffic but before the firewall dynamically changes the private IP addresses to public IP addresses as shown in the diagram on attachment A. The filtering servers and reporting servers **must** operate within the scope of the K-12 private network so that filtering control and reporting will reflect the private IP addresses of the client computers. In the event that portable computers are connected to residential, public, or other networks, an option **must** be available to provide continued filtering of Internet web sites. No caching appliances are currently in use; however the Internet filtering solution **must** support the option for the WVDE to install caching appliances.

The quoted solution **must** be designed to accommodate peak usage at each of the two POP sites. Peak usage is defined as 100,000 computers, 140,000 users, **and** 10Gbps of bandwidth to the Internet at each POP site.

2.1.1 Section II – Technical Requirements

The vendor bid **must** provide an Internet filtering solution capable of filtering 200,000 total computers in a network consisting of two POPs with 280,000 users. The solution **must** be configured to support 100,000 client computers and 140,000 users using 10 gigabits/sec of bandwidth at each POP.

The vendor **must** provide evidence of at least one current, successful installation of the Internet filtering solution in a network configuration servicing 100,000 computers and 140,000 users with 10 gigabits/second of Internet bandwidth. This evidence must include details regarding the size and scope of the successful project(s) as well as contact name(s) and phone number(s) for customer(s) where the successful Internet filtering solution was implemented. The vendor must submit a memo from the successful customer (on customer's letterhead, dated and signed) describing the size and scope of the successful project, as well as any issues (if any) and how they were resolved.

The filtering solution **must** be a POP based installation capable of providing a level of service appropriate for an Internet Service Provider (ISP); a filtering solution which involves the installation of filtering software or hardware within school districts or individual schools is **not** acceptable.

The vendor **must** provide Internet filtering and reporting application software and all necessary supporting software including, but not limited to, operating system and database software.

The Internet filtering solution **must** meet the requirements of this RFQ using servers/appliances provided by the vendor or when installed on the WVDE owned equipment identified in Section I – Current Environment.

The WVDE will provide server hardware, equipment racks, networking components and cabling as specified in Section I – Current Environment.

The filtering solution **must** support gigabit speed, copper based, Ethernet network interfaces.

The filtering solution **must** not exceed a total of 12 servers or appliances at each POP.

The total of all hardware components of the filtering solution for each POP **must** be rack mountable and not occupy more than 24 units of rack space (about 48") at each POP site. The equipment **must** operate on 110-120 Volts AC power.

In the event the winning bid does not meet the requirements of this RFQ when installed on vendor provided server/appliances or on the existing equipment identified in Section I-Current Environment, the vendor **must** provide additional servers and any other associated installation, shipping, labor and configuration expenses at no cost to the WVDE or the contract will be immediately terminated.

There **must** be no requirement for any configuration changes of any networking equipment or computers that are connected to the private WV K-12 network at the school districts or individual schools.

The filtering solution **must** provide client software which can be installed on mobile computers that will enforce the same filtering parameters whether a mobile computer is connected to the WV K-12 network or connected by wired or wireless networking to the Internet via any other Internet service provider. The client software **must** not be a VPN (virtual private networking) or similar type of client and **must** not rely on a web browser setting such as proxy server configuration.

The filtering solution **must** have the capability to filter based on the IP address of the client computer and not require user authentication.

The filtering solution **must** have the capability to be integrated with unified authentication systems such as LDAP and Active Directory service.

The Internet filtering solution **must** be engineered and operate with redundancy such that the failure of one server or appliance at a POP will not reduce the capability to provide filtering for 100,000 computers and 140,000 users at 10 gigabits/sec of throughput.

### 2.1.2 Internet Filtering

The filtering solution **must** provide a web based interface for all management and configuration tasks which can be performed by WVDE.

The filtering solution **must** have the capability to be configured to block Internet access in the event of the failure of the filtering solution at a POP so that unfiltered Internet access is prevented.

The Internet filtering solution provided as a result of this RFQ **must** be verified by the vendor to meet the requirements of the Children's Internet Protection Act (CIPA) (refer to <http://www.fcc.gov/guides/childrens-internet-protection-act>) and the West Virginia Board of Education Policy 2460 which is available online at <http://wvde.state.wv.us/policies/policy.php?p=2460&alt=1>.

Specifically, CIPA states that technology protection measures (filtering solutions) must block or filter Internet access to pictures that are: (a) obscene; (b) child pornography; or (c) harmful to minors. The filtering solution **must** block access to this CIPA specified content.

CIPA also states that schools receiving E-Rate must monitor the online activities of minors. Therefore, the Internet filtering solution **must** include the ability to configure logging of all allowed and blocked Internet requests.

The filtering solution **must** be verified by the vendor to comply with the Children's Online Privacy Protection Act (COPPA) (refer to <http://www.ftc.gov/ogc/coppa1.htm>). The filtering process **must** not require the collection of any personal information from any users under the age of 13.

The filtering solution **must** provide the capability for the WVDE to selectively enable filtering of content based on categories of web sites or individual web sites using the http and https protocols.

The vendor **must** include all categories that the vendor offers on the product. The vendor **must** not offer a reduced number of categories in an attempt to reduce costs by providing only the categories that are identified in this RFQ.

The vendor **must** provide, but is not limited to, the pre-populated categories of the following classifications or equivalent classifications of content on web sites:

- Pornography
- Obscenity
- Dating (including sites for the purpose of establishing personal relationships)
- Gambling
- Criminal Activities (sites that condone or provide instructions for criminal activity)
- Illegal Drugs (sites that condone or provide instructions for illegal drug use, manufacturing and distribution)
- Anonymous Proxies (anonymizers to bypass filtering or hide the true source of Internet activity)
- Computer crimes, cracking and hacking (sites that condone or provide instructions for these activities)
- Malicious code (sites that contain, distribute, or execute malicious code such as malware, viruses, root kits, bots, etc or retrieve information from computers that are infected with malicious code)
- Instant messaging sites



-Peer to Peer (P2P sites)

-Phishing (fraudulent sites that imitate authentic sites, often to lure people into submitting personal or financial information.)

-Hate, racism, discrimination (sites that condone or encourage violence against or suppression of any minorities or grouping based on race, religion, sexual orientation, ethnicity or any other social grouping characteristic)

The filtering solution **must** have the capability to allow or deny access to any individual web site, URL, or IP address whether or not it is included in any vendor provided category.

The filtering solution **must** have the capability to permit the WVDE to create unlimited additional custom categories.

The filtering solution **must** have the capability to permit the use of "regular expressions" (includes wild-card characters and other variables to specify complex text strings) when creating custom allow or deny lists of URL web addresses or search terms.

The filtering solution **must** have the capability to block traffic related to peer-to-peer file sharing protocols.

The filtering solution **must** have the capability to enforce the "safe searching" mode of Google, Bing and Yahoo search engines, regardless of the settings chosen by an end user while accessing those search engines.

The filtering solution **must** provide capabilities to create manageable client groups based on IP address ranges and assign names to those groups.

The capability **must** exist to delegate management of groups by creating additional administrators with restricted rights who can be assigned to manage filtering parameters for specific groups.

The filtering solution **must** provide for customizable, granular permissions so that additional administrator/user accounts can be tailored on a user by user basis to match the rights of a user to the tasks that a user needs to perform.

The filtering solution **must** have the capability to selectively display WVDE customized "site blocked" pages based on the client group and/or the categorization of the blocked web site.

The filtering solution **must** have the capability to selectively display WVDE customized "informational" pages based on the client group and/or the categorization of web sites to which access is allowed.

The filtering solution **must** have the capability to be configured to only perform filtering of outgoing requests and to perform no filtering of incoming traffic.

The product offered by the vendor **must** perform Internet filtering primarily by comparing outgoing requests to a database of categorized URLs and IP addresses to determine whether an attempt to access a site on the Internet is to be blocked or permitted.

Any other Internet filtering methods of the filtering solution, such as “on the fly” evaluation of incoming content, **must** be able to be selectively disabled at the option of the WVDE.

The filtering solution **must** provide a web based display of status and performance graphs for all components of the filtering solution.

The filtering solution **must** have the capability for the WVDE to set customized filtering policies based on the time of day and the day of the week for individual IP addresses and/or groups of client IP addresses.

The Internet filtering solution **must not** masquerade, spoof or change the source IP address of the computers on the K-12 network. The source IP address of the client computer **must** be passed to the PIX firewall.

The Internet filtering and reporting servers **must** operate on and report on the 10.0.0.0 private network IP addresses of the WVDE K-12 network.

The filtering solution **must** have a synchronization capability. Synchronization means that when the WVDE makes a filtering configuration change using the web management tool, that change will be distributed to all of the filtering servers at both POPs. That change distribution **must** take effect automatically within 5 minutes after the act of saving the configuration change, or be accomplished manually with no more than 5 mouse clicks after the configuration change is saved.

### **2.1.3 Internet Use Reporting**

The filtering solution **must** provide a web-based reporting application and a minimum of one terabyte of log file storage at each POP.

The filtering solution **must** provide a method for the WVDE to download log files in a generic text format for analysis and archival storage.

Complete details of web browsing activity **must** be stored in log files and **must** include, at a minimum, the complete URL, date and time and IP address of the client computer.

All end user functions of the reporting application **must** be accessible via a web interface.

REQUEST FOR QUOTATION  
EDD392953 Internet Filtering and Reporting Solution

28

contract. The vendor is responsible for any transportation, and lodging costs of the installer, as well as for any freight or shipping charges for equipment.

The Internet filtering solution **must** support the bandwidth requirements of 10 gigabits/sec and 100,000 client computers/140,000 users at each one of the two POPs as identified in the specifications in Section II-Technical Requirements.

The vendor understands that technical support includes verifying that all hardware and/or software remains operational in the event of WVDE modification, replacement or upgrade of any servers or network configurations that impact the functioning of the filtering solution. These costs are to be included in the line item for technical support on the cost page.

Toll-free telephone and e-mail technical support **must** be available 7:00 AM to 5:00 PM Monday through Friday, Eastern Time (GMT -0500) for designated WVDE networking staff. Any costs associated with this requirement are to be included in the line item for technical support on the cost page.

The vendor **must** provide a function that permits any user of the WV K-12 network to submit a web site to be reviewed and appropriately categorized by the vendor. This function allows the vendor to receive feedback with the intent of improving delivery of services or product functionality.

**2.1.7 Vendor Response**

The vendor **shall** complete the Cost Worksheet.

The vendor **must** provide evidence of at least one current, successful installation of the Internet filtering solution in a network configuration servicing 100,000 or more computers/140,000 users with 10 gigabits/second or more of Internet bandwidth. The following table **shall** be used in the vendors response.

Project Name	Contact name and phone number	# of computers filtered	# of users supported	Internet bandwidth

---

If the vendor fails to identify any costs that are required to meet the terms, requirements and conditions of this Quotation, it shall be the responsibility of the successful vendor to pay those costs and such costs will not be passed on to the WVDE or the State of West Virginia.

Pricing **must** be stated on the basis of one-year contracts.

The actual number of licenses purchased may vary from year to year. The quantities of computers and users listed on the Cost Worksheets are estimates only. The actual quantity to be purchased will be specified in a purchase order release.

Filtering licensing prices **must** be quoted based on the number of users filtered annually so that the WVDE can determine the basis of the pricing submitted in the quote.

Software updates/upgrades and technical support **must** be priced on an annual basis and this item is reflected as such on the cost page.

The vendor is responsible for any costs due to product end of life that will require replacement or upgrading of the vendor provided software or hardware during the term of the contract.

### 3. CONTRACT AWARD:

- 3.1 Contract Award:** The Contract is intended to provide Agencies with a purchase price on all Contract Items. The Contract shall be awarded to the Vendor that provides the Contract Items meeting the required specifications for the lowest overall total cost as shown on the Pricing Pages. The Unit Cost per each item listed on the Pricing Page shall remain firm for the life of the contract.

**Pricing Pages:** Vendor should complete the Pricing Pages and All Quotes shall be all inclusive. No separate reimbursements will be made for travel, freight, or any other expense.

The Contract shall be awarded to the responsible Vendor with the lowest grand total costs to provide a complete Internet filtering solution, including software, filtering updates, licensing, technical support and maintenance according to the specifications. As previously explained, the vendor **must** also include servers in the bid if the filtering solution cannot meet the requirements of this RFQ when installed on the WVDE equipment identified in Section I – Current Environment.

The contract shall be for a period of one year with the potential for two (2) one year renewals. The actual number of licenses purchased each year will be based on a count of end users, provided by the WVDE, on the date of the annual contract renewal(s). Contract renewals for

years two and three shall include software license fees, filtering updates, technical support and maintenance, and may also include any additional item(s) listed in the vendor response meeting specifications.

- 1.1** Vendor should complete the Pricing Pages in their entirety as failure to do so may result in Vendor's bids being disqualified. Additional information can be found on the Pricing Pages.

The Pricing Pages contain a list of the Contract Items. No future use of the Contract or any individual item is guaranteed or implied.

Notwithstanding the foregoing, the Purchasing Division may correct errors at its discretion. Vendor should type or electronically enter the information into the Pricing Pages to prevent errors in the evaluation. The Pricing Pages were created as a Microsoft Excel document and Vendor can request an electronic copy for bid purposes by sending an email request to the following address: [Connie.S.Oswald@wv.gov](mailto:Connie.S.Oswald@wv.gov)

**2. ORDERING AND PAYMENT:**

- 2.1 Ordering:** Vendor shall accept orders by regular mail, facsimile, e-mail, or any other written forms of communication. Vendor may, but is not required to, accept on-line orders through a secure internet ordering portal/website. If Vendor has the ability to accept on-line orders, it should include in its response a brief description of how Agencies may utilize the on-line ordering system. Any on-line ordering system must have the capability to restrict prices and available items to conform to the Catalog originally submitted with this RFQ. Vendor shall ensure that its on-line ordering system is properly secured prior to processing Agency orders on-line.
- 2.2 Payment:** Vendor shall accept payment in accordance with the payment procedures of the State of West Virginia.

3. MISCELLANEOUS:

- 3.1 **No Substitutions:** Vendor shall supply only Contract Items submitted in response to the RFQ unless a contract modification is approved in accordance with the provisions contained in this Contract.
- 3.2 **Vendor Supply:** Vendor must carry sufficient inventory of the Contract Items being offered to fulfill its obligations under this Contract. By signing its bid, Vendor certifies that it can supply the Contract Items contained in its bid response.
- 3.3 **Reports:** Vendor shall provide quarterly reports and annual summaries to the Agency showing the Agency's items purchased, quantities of items purchased, and total dollar value of the items purchased. Vendor shall also provide reports, upon request, showing the items purchased during the term of this Contract, the quantity purchased for each of those items, and the total value of purchases for each of those items. Failure to supply such reports may be grounds for cancellation of this Contract.
- 3.4 **Cancellation:** The Director of Purchasing reserves the right to cancel this contract immediately upon written notice to the vendor if the commodities and /or services supplied are of an inferior quality or do not conform to the specifications of the bid and contract herein.

**The vendor shall not knowingly make or submit false material statements or information. If false or fraudulent information is provided, the awarded contract shall be cancelled and awarded to the next lowest bidder meeting specifications.**

- 3.5 **Renewals:** This contract may be renewed upon the mutual written consent of the spending unit and vendor, submitted to the Director of Purchasing thirty (30) days prior to the expiration date. Such renewal shall be in accordance with the terms and conditions of the original contract and shall be limited to two (2) one year periods.
- 3.6 **Contract Manager:** During its performance of this Contract, Vendor must designate and maintain a primary contract manager responsible for overseeing Vendor's responsibilities under this Contract. The Contract manager must be available during normal business hours to address any customer service or other issues related to this Contract. Vendor should list its Contract manager and his or her contact information below.

**Contract Manager:** Tara Barbieri - Director, Program Manager  
**Telephone Number:** 203-851-7144  
**Fax Number:** \_\_\_\_\_  
**Email Address:** tara@cdwg.com

**Note 1:** A mobile computer requires special client software that will force the computer to be filtered even when it is disconnected from the K-12 network and connected to any other network which provides Internet access. If there is no price difference for mobile computers, enter the same unit cost as for computers on the K-12 network.

**Note 2:** Costs for training and installation, configuration and testing **must** be inclusive of all incidental costs. Travel expenses, training materials and other reimbursable expenses will not be paid separately. The distance between Charleston and Morgantown WV is approximately 180 miles.

**Item Pricing:**

This worksheet is for vendors to identify items, quantities and provide prices. The vendor should indicate "No Cost" or "N/A" in the appropriate cells or blanks of the cost worksheet for which there are no separate or applicable costs. Any cost area that is left blank will be assumed to be "No Cost." The vendor may add notes to explain or clarify the bid.

\* Vendor is encouraged to provide unit pricing for each of these items. However, it shall be the responsibility of the vendor to determine sufficient quantities needed for the scope of work outlined in the RFQ. For example, the quantity of servers needed to provide coverage for the WVDE's network may be set at one for vendor A, but be determined to be 5 by vendor B, due to design efficiencies.

Signature:  Date: 6/12/2013

Company Name: CDW Government LLC

Address: 230 N. Milwaukee Ave., Vernon Hills, IL 60061

Phone: 866.850.5724

Fax: 847-990-8190

Email: mikepin@cdw.com

# Attachment A

## West Virginia Department of Education K-12 State Network

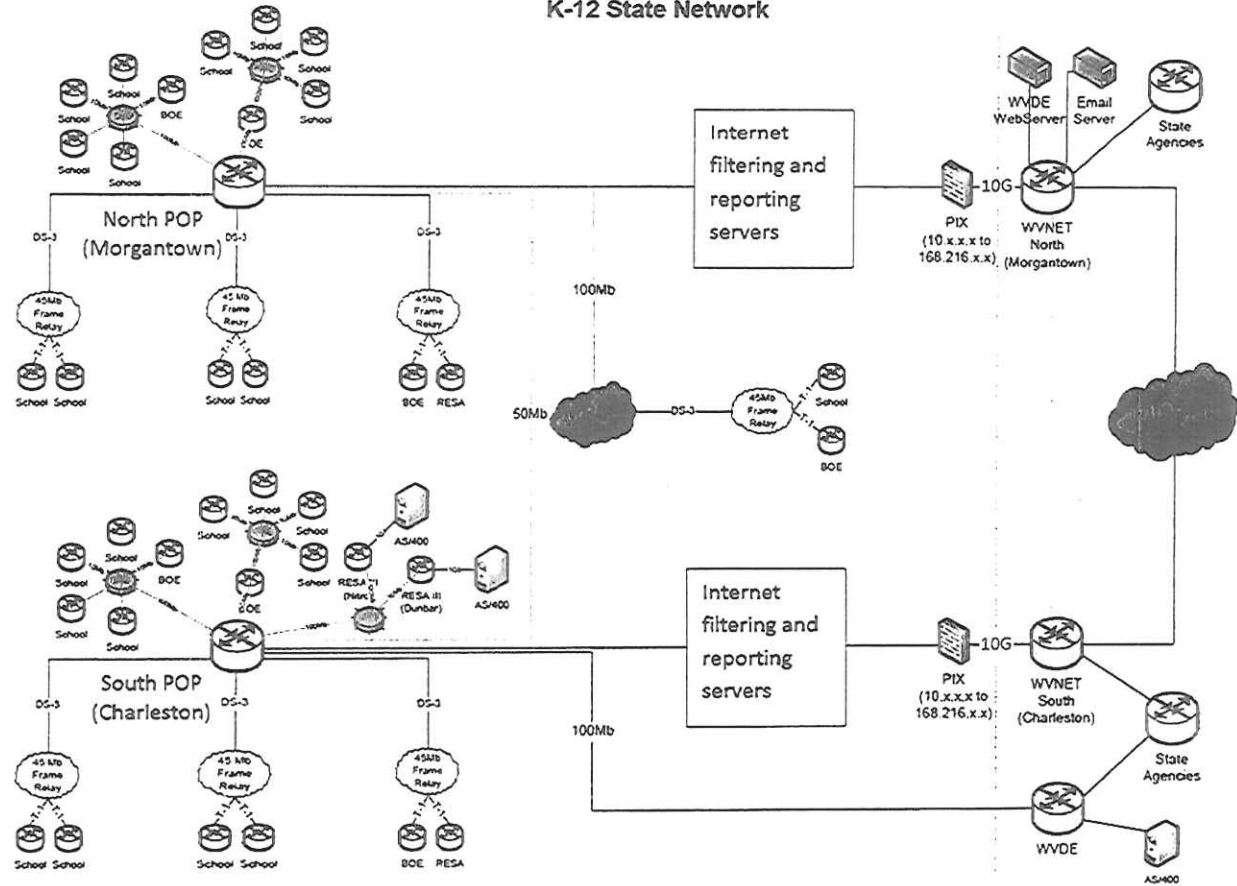

Version 3.21.2013



WV-96A  
Rev. 12/12

**AGREEMENT ADDENDUM FOR SOFTWARE**

In the event of conflict between this addendum and the agreement, this addendum shall control:

1. **DISPUTES** - Any references in the agreement to arbitration or to the jurisdiction of any court are hereby deleted. Disputes arising out of the agreement shall be presented to the West Virginia Court of Claims.
2. **HOLD HARMLESS** - Any provision requiring the Agency to indemnify or hold harmless any party is hereby deleted in its entirety.
3. **GOVERNING LAW** - The agreement shall be governed by the laws of the State of West Virginia. This provision replaces any references to any other State's governing law.
4. **TAXES** - Provisions in the agreement requiring the Agency to pay taxes are deleted. As a State entity, the Agency is exempt from Federal, State, and local taxes and will not pay taxes for any Vendor including individuals, nor will the Agency file any tax returns or reports on behalf of Vendor or any other party.
5. **PAYMENT** - Any references to prepayment are deleted. Fees for software licenses, subscriptions, or maintenance are payable annually in advance. Payment for services will be in arrears.
6. **INTEREST** - Any provision for interest or charges on late payments is deleted. The Agency has no statutory authority to pay interest or late fees.
7. **NO WAIVER** - Any language in the agreement requiring the Agency to waive any rights, claims or defenses is hereby deleted.
8. **FISCAL YEAR FUNDING** - Service performed under the agreement may be continued in succeeding fiscal years for the term of the agreement, contingent upon funds being appropriated by the Legislature or otherwise being available for this service. In the event funds are not appropriated or otherwise available for this service, the agreement shall terminate without penalty on June 30. After that date, the agreement becomes of no effect and is null and void. However, the Agency agrees to use its best efforts to have the amounts contemplated under the agreement included in its budget. Non-appropriation or non-funding shall not be considered an event of default.
9. **STATUTE OF LIMITATION** - Any clauses limiting the time in which the Agency may bring suit against the Vendor, lessor, individual, or any other party are deleted.
10. **SIMILAR SERVICES** - Any provisions limiting the Agency's right to obtain similar services or equipment in the event of default or non-funding during the term of the agreement are hereby deleted.
11. **FEES OR COSTS** - The Agency recognizes an obligation to pay attorney's fees or costs only when assessed by a court of competent jurisdiction. Any other provision is invalid and considered null and void.
12. **ASSIGNMENT** - Notwithstanding any clause to the contrary, the Agency reserves the right to assign the agreement to another State of West Virginia agency, board or commission upon thirty (30) days written notice to the Vendor and Vendor shall obtain the written consent of Agency prior to assigning the agreement.
13. **LIMITATION OF LIABILITY** - The Agency, as a State entity, cannot agree to assume the potential liability of a Vendor. Accordingly, any provision in the agreement limiting the Vendor's liability for direct damages is hereby deleted. Vendor's liability under the agreement shall not exceed three times the total value of the agreement. Limitations on special, incidental or consequential damages are acceptable. In addition, any limitation is null and void to the extent that it precludes any action for injury to persons or for damages to personal property.
14. **RIGHT TO TERMINATE** - Agency shall have the right to terminate the agreement upon thirty (30) days written notice to Vendor. Agency agrees to pay Vendor for services rendered or goods received prior to the effective date of termination. In such event, Agency will not be entitled to a refund of any software license, subscription or maintenance fees paid.
15. **TERMINATION CHARGES** - Any provision requiring the Agency to pay a fixed amount or liquidated damages upon termination of the agreement is hereby deleted. The Agency may only agree to reimburse a Vendor for actual costs incurred or losses sustained during the current fiscal year due to wrongful termination by the Agency prior to the end of any current agreement term.
16. **RENEWAL** - Any reference to automatic renewal is deleted. The agreement may be renewed only upon mutual written agreement of the parties.
17. **INSURANCE** - Any provision requiring the Agency to purchase insurance for Vendor's property is deleted. The State of West Virginia is insured through the Board of Risk and Insurance Management, and will provide a certificate of property insurance upon request.
18. **RIGHT TO NOTICE** - Any provision for repossession of equipment without notice is hereby deleted. However, the Agency does recognize a right of repossession with notice.
19. **ACCELERATION** - Any reference to acceleration of payments in the event of default or non-funding is hereby deleted.
20. **CONFIDENTIALITY** - Any provision regarding confidentiality of the terms and conditions of the agreement is hereby deleted. State contracts are public records under the West Virginia Freedom of Information Act.
21. **AMENDMENTS** - All amendments, modifications, alterations or changes to the agreement shall be in writing and signed by both parties. No amendment, modification, alteration or change may be made to this addendum without the express written approval of the Purchasing Division and the Attorney General.

ACCEPTED BY:

STATE OF WEST VIRGINIA

VENDOR

Spending Unit: \_\_\_\_\_

Company Name: \_\_\_\_\_

Signed: \_\_\_\_\_

Signed: \_\_\_\_\_

Title: \_\_\_\_\_

Title: \_\_\_\_\_

Date: \_\_\_\_\_

Date: \_\_\_\_\_

\*\* To be signed upon award \*\*

Attachment  
PO# EDD392953

This agreement constitutes the entire agreement between the parties, and there are no other terms and conditions applicable to the licenses granted hereunder.

Agreed

\_\_\_\_\_  
Signature                      Date

\_\_\_\_\_  
Title

\_\_\_\_\_  
Company Name

\_\_\_\_\_  
Signature                      Date

\_\_\_\_\_  
Title

\_\_\_\_\_  
Agency/Division

\*\* To be signed upon award \*\*



State of West Virginia  
 Department of Administration  
 Purchasing Division  
 2019 Washington Street East  
 Post Office Box 50130  
 Charleston, WV 25305-0130

**Solicitation**

NUMBER
EDD392953

PAGE
1

ADDRESS CORRESPONDENCE TO ATTENTION OF:
CONNIE OSWALD 304-558-2157

RFQ COPY  
 TYPE NAME/ADDRESS HERE

V  
E  
N  
D  
O  
R

DEPARTMENT OF EDUCATION  
 BUILDING 6  
 1900 KANAWHA BOULEVARD, EAST  
 CHARLESTON, WV  
 25305-0330

S  
H  
I  
P  
T  
O

DATE PRINTED
05/30/2013

BID OPENING DATE: 06/13/2013 BID OPENING TIME 1:30PM

LINE	QUANTITY	UOP	CAT. NO.	ITEM NUMBER	UNIT PRICE	AMOUNT
				ADDENDUM NO. 1		
				1. TO PROVIDE ANSWERS TO QUESTIONS RECEIVED.		
				2. TO PROVIDE THE ADDENDUM ACKNOWLEDGMENT. THIS DOCUMENT SHOULD BE RETURNED WITH YOUR BID. FAILURE TO RETURN MAY RESULT IN DISQUALIFICATION OF YOUR BID.		
				END OF ADDENDUM NO. 1		

SIGNATURE	TELEPHONE 866.850.5724	DATE 6/12/2013
TITLE John Loughlin - Supervisor, Proposals	FEIN 36-4230110	ADDRESS CHANGES TO BE NOTED ABOVE

WHEN RESPONDING TO SOLICITATION, INSERT NAME AND ADDRESS IN SPACE ABOVE LABELED 'VENDOR'

SOLICITATION NUMBER: EDD392953

Addendum Number: 01

---

The purpose of this addendum is to modify the solicitation identified as (“Solicitation”) to reflect the change(s) identified and described below.

**Applicable Addendum Category:**

- Modify bid opening date and time
- Modify specifications of product or service being sought
- Attachment of vendor questions and responses
- Attachment of pre-bid sign-in sheet
- Correction of error
- Other

**Description of Modification to Solicitation:**

1. To provide answers to questions received.
2. To provide the addendum acknowledgment.

**Additional Documentation:** Documentation related to this Addendum (if any) has been included herewith as Attachment A and is specifically incorporated herein by reference.

**Terms and Conditions:**

1. All provisions of the Solicitation and other addenda not modified herein shall remain in full force and effect.
2. Vendor should acknowledge receipt of all addenda issued for this Solicitation by completing an Addendum Acknowledgment, a copy of which is included herewith. Failure to acknowledge addenda may result in bid disqualification. The addendum acknowledgement should be submitted with the bid to expedite document processing.

ATTACHMENT A

EDD392953

## Questions &amp; Responses

1Q.	Do they require 10g interfaces on the filtering appliances?
1R.	No. It is not required that each appliance/server have 10Gbps interfaces. The solution must support 10Gbps of total bandwidth, which is the total bandwidth at each POP. All traffic should not pass through the appliance(s)/server(s) – only web requests pass through the filtering device(s). Therefore the solution must be capable of supporting filtering of 10Gbps total bandwidth. This can be accomplished with a single device with a 10Gbps interface or with multiple devices with smaller interfaces which collectively support the total required bandwidth.
2Q.	Do they require anti-malware scanning as part of the filtering solution?
2R.	No
3Q.	Do they have load balancers at their two POPs?
3R.	No
4Q.	How is their current solution deployed? Inline, proxy, wccp?
4R.	Inline with multiple devices handling requests via round-robin routing.
5Q.	Existing Internet Filtering and Reporting Solutions in place now?
5R.	Netsweeper is the vendor currently providing a filtering solution installed on equipment outlined in Section 1 – Current Environment.
6Q.	Are there any addendums to date for this RFQ?
6R.	No, as of today, May 28, 2013.



# SALES QUOTATION

QUOTE NO.	ACCOUNT NO.	DATE
DMPQ253	6280704	6/10/2013

**BILL TO:**  
 WEST VIRGINIA DEPT OF  
 EDUCATION  
 1900 KANAWHA BLVD E  
 BUILDING 7, ROOM 5

**SHIP TO:**  
 WEST VIRGINIA DEPT OF EDUCATION  
 Attention To: CONNIE OSWALD  
 1900 KANAWHA BLVD E  
 BUILDING 7, ROOM 5

Accounts Payable  
 CHARLESTON , WV 25305-0009

CHARLESTON , WV 25305-0009  
 Contact: CONNIE  
 OSWALD 304.558.2157

Customer Phone #304.558.7880

Customer P.O. # RFP WEB FILTERING

ACCOUNT MANAGER		SHIPPING METHOD	TERMS	EXEMPTION CERTIFICATE
MIKE PINTO 866.850.5724		UPS Ground (2- 3 Day)	Net 30 Days-Govt State/Local	GOVT-EXEMPT
QTY	ITEM NO.	DESCRIPTION	UNIT PRICE	EXTENDED PRICE
20	2735622	MCAFFEE FED WEB GTW 5500 APPL B 1+ Mfg#: WBG-5500-BI Contract: WV State and Local Government Pricing List Price \$20995.00 Electronic distribution - NO MEDIA	10,224.00	204,480.00
20	2435997	MCAFFEE WEB GTW 5500 APPL B-1YR GL+ Mfg#: WBG5500BARMAI Contract: WV State and Local Government Pricing List price \$ 4199.00 1 year support for line 1 Electronic distribution - NO MEDIA	2,556.00	51,120.00
10001	2472283	MCAFFEE WEB PROT STE 1:1 10001-20K Mfg#: WPSECE-AA-JI Contract: WV State and Local Government Pricing List price \$9.37 includes a year of support Electronic distribution - NO MEDIA	6.10	61,006.10
4	2186286	MCAFFEE GHE SOL SVC SML DPLY CONSULT Mfg#: MD-SMALL-DEPLOYI Contract: WV State and Local Government Pricing List price \$17,000 Electronic distribution - NO MEDIA	16,000.00	64,000.00
190000	2383156	MCAFFEE WEB SEC P:1 50001+ Mfg#: WSGCKE-AA-LI Contract: WV State and Local Government Pricing List price \$ 7.56 includes a year of support Electronic distribution - NO MEDIA	0.85	161,500.00
1	2769153	HP SB PROLIANT DL385P GEN8 6234 Mfg#: 686852-S01 Contract: WV State and Local Government Pricing	2,825.00	2,825.00
6	2806500	HP SB 8GB 2RX4 PC3L-10600R-9 KIT Mfg#: 647877-S21 Contract: WV State and Local Government Pricing	88.00	528.00
6	2775192	HP 900GB 6G SAS 10K 2.5 GEN8 Mfg#: 652589-S21 Contract: WV State and Local Government Pricing	623.00	3,738.00
1	1706188	CDW HARDWARE INSTALL SERVER Mfg#: HWINSTALLSERVER Contract: WV State and Local Government Pricing	30.00	30.00
1	076980	CDW NETWORK OPERATING SYSTEM INSTALL Mfg#: INSTALLNETOS Contract: WV State and Local Government Pricing	230.00	230.00
1	931000	CDW NETWORK APPLICATION INSTALL Mfg#: INSTALLNETSOFTWARE Contract: WV State and Local Government Pricing	120.00	120.00
2	2803261	ACAD MS MBA WIN SRV STD 2012 2PROC Mfg#: P73-05828 Contract: WV State and Local Government Pricing Electronic distribution - NO MEDIA	210.00	420.00

12	2668369	ACAD MS MBA SQL SRV STD CORE 2LIC Mfg#: 7NQ-00256 Contract: WV State and Local Government Pricing Electronic distribution - NO MEDIA	870.00	10,440.00
			SUBTOTAL	560,437.10
			FREIGHT	0.00
			TAX	0.00
				US Currency
<b>TOTAL ↗</b>				<b>560,437.10</b>

CDW Government  
230 North Milwaukee Ave.  
Vernon Hills, IL 60061

Fax: 847.990.8190

**Please remit payment to:**  
CDW Government  
75 Remittance Drive  
Suite 1515  
Chicago, IL 60675-1515



## References

CDWG would be happy to supply customer introductions to our customer references should McAfee be considered a finalist in the selection process. We are careful to protect our reference customers from inquires as we are respectful of their privacy and available time and resources. In the event a reference call is needed in the near future, we would be happy to reach out to the following customers: **Merck, FedEx, Advance Auto Parts and LA County School District** to establish an introduction to one of them for you. These reference names are provided based on the RFP requirements and a reference call will be established based on this selection process and reference availability. Please contact your account manager, Mike Pinto, at 866-850-5724 listed in this RFP if you have any questions.

LA School District: 110,000 users

FedEx: 200,000 users

Merck: 72,000 users

Advance Auto Parts: 50,000 users

# McAfee Solution Services Packaged Implementation Offerings

## Essential Services for McAfee® Web Gateway

Intelligent security by design: Expert advice to help you realize the full value of your McAfee security solution. The McAfee Solution Services delivery methodology utilizes best practices enabling faster product implementation and the powerful new rules-based engine in your McAfee Web Gateway.

### Key Points

Our global team of security specialists implements the best practices vital to any successful security rollout, regardless of size, enabling you to lock in long-term advantages for both your IT environment and your business.

### Benefits

Ensure your McAfee products are correctly configured:

- Integration with existing infrastructure
- Delivers rapid return on your security investment (ROI)
- Hands-on knowledge transfer provides an introduction to deployment, configuration, and common administration practices

### Additional Services

McAfee Solution Services helps you:

- Align business and security objectives
- Meet compliance requirements
- Achieve comprehensive planning and guidance
- Effectively maintain your McAfee security solutions
- Apply operational best practices
- Prepare for upgrades and migrations

### McAfee Solution Services

McAfee Solution Services offers a team of certified security experts who provide a unique combination of knowledge, experience, and resources to reduce implementation risk, accelerate time to protection, and optimize the return on your security technology investment.

### McAfee Solution Services Objectives

McAfee Solution Services implementation packages focus on the plan, design, and implement phases of your McAfee security solution deployment.

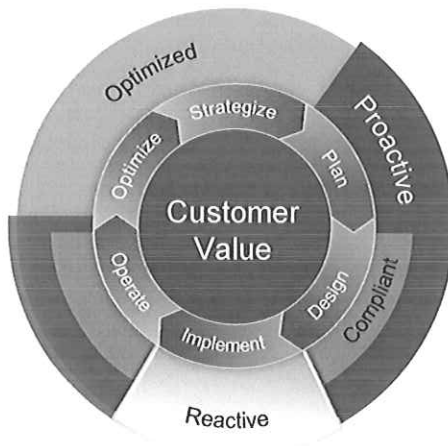

Additional services are available to provide a customized solution that aligns your business needs and compliance objectives throughout the security management lifecycle.

### Reduce Implementation Delays

Reduce the delays that can result from the initial learning curve of new technologies, costly fault-finding, and remediation.

### Product Installation

- McAfee Web Gateway
- McAfee Web Reporter
- Install product extensions for integration with McAfee ePolicy Orchestrator® (McAfee ePO™) software

### Product Management

- Centralized management
- Integration with McAfee ePO software

### Maximize Value

Rely on a proven methodology to help you fully leverage McAfee technology solutions and maximize your investment. Our services span the entire McAfee portfolio of solutions, from security risk assessments to comprehensive, customized deployments.

### Integrate and Lower TCO

Centralized management and integrated solutions make it easy and cost effective for companies.

Description of Services

Scope	Small-Deploy	Mid-Deploy	Large-Deploy
Installation of McAfee Web Gateway	Up to five at one site	Up to 10 at up to two sites	Up to 20 at up to four sites
Installation of McAfee Web Reporter	One	Up to two	Up to two
Development of URL category filtering rule sets	Up to five total	Up to 10 total	Up to 25 total
Development of gateway anti-malware rule sets	Up to two total	Up to four total	Up to 10 total
Apply baseline policy configuration	Included	Included	Included

Key Advantages

McAfee Solution Services delivery follows a proven methodology:

- Provides a set of actionable plans
- Delivered by McAfee Product Specialists
- Learn during your implementation

Ordering Information

Three packaged implementation offerings are available to meet your organization's deployment objectives:

- MD-SMALL-DEPLOY
- MD-MID-DEPLOY
- MD-LARGE-DEPLOY

Customer Requirements

- Complete the pre-engagement questionnaire
- Complete and verify system backups in accordance with your requirements
- Completed architecture design diagrams
- Physical installation of appliances
- Complete the firewall configuration for use with the McAfee Web Gateway
- An existing McAfee ePO software installation, where integration is required

Planning

McAfee will review the current network architecture, change control, and other business processes to facilitate the implementation of your McAfee security solution.

Design and Installation

- Execute the initial installation wizard
  - » Set IP addresses
  - » Domain names
  - » DNS
  - » NTP servers

Configuration and Deployment

- Import product licenses
- Configuration and connectivity testing
- Creation of McAfee Web Gateway user accounts and permissions
- Apply baseline policies
- Configuration of custom options per customer requirements
- Configure logging options
- Configure notification options
- Customization of block pages
- Conduct end-user testing
- Configuration of log sources
- Configuration of reporting accounts and authentication
- Creation of scheduled reports

Knowledge Transfer

Knowledge transfer to your team occurs interactively during the course of the engagement and covers the installation, configuration, and administration of the McAfee security solution.

Learn More

For comprehensive, proactive protection across the enterprise, McAfee Solution Services offers customized services for businesses with complex requirements. Visit [www.mcafee.com](http://www.mcafee.com), or email us at [SolutionServices@mcafee.com](mailto:SolutionServices@mcafee.com).



## Requirements Response

POP Site #1 Charleston, WV, is equipped with the following WVDE owned servers on which the filtering solution may be installed.

8 (eight) Dell 2850 servers with following specifications:

3 GHz XEON Processor with 2 MB cache, 2 GB DDR2 dimm, dual 73GB scsi drives in mirrored RAID, dual onboard gigabit copper ethernet NICs.

1 (one) Dell 2850 servers with following specifications:

3 GHz XEON Processor with 2 MB cache, 2 GB DDR2 dimm, dual 73GB scsi drives in mirrored RAID, dual onboard gigabit copper ethernet NICs, and one 1 TB storage for reports and log files.

POP Site #2 Morgantown, WV, is equipped with the following WVDE owned servers on which the filtering solution may be installed:

8 (eight) Dell 2850 servers with following specifications:

3 GHz XEON Processor with 2 MB cache, 2 GB DDR2 dimm, dual 73GB scsi drives in mirrored RAID, dual onboard gigabit copper ethernet NICs.

1 (one) Dell 2850 servers with following specifications:

3 GHz XEON Processor with 2 MB cache, 2 GB DDR2 dimm, dual 73GB scsi drives in mirrored RAID, dual onboard gigabit copper ethernet NICs, and one 1 TB storage for reports and log files.

If the servers described above are not adequate to support the vendor's filtering solution, the vendor must include appropriate servers or appliances and associated costs in the response to this RFQ.

The total number of computers to be filtered is approximately 140,000 computers. The Internet filtering must occur at the point in the network after which the K-12 core routers consolidate Internet traffic but before the firewall dynamically changes the private IP addresses to public IP addresses as shown in the diagram on attachment A. The filtering servers and reporting servers must operate within the scope of the K-12 private network so that filtering control and reporting will reflect the private IP addresses of the client computers. In the event that portable computers are connected to residential, public, or other networks, an option must be available to provide continued filtering of Internet websites. No caching appliances are currently in use: however the Internet filtering solution must support the option for the WVDE to install caching appliances.

### Section II – Technical Requirements

#### General

The vendor bid must provide an Internet filtering solution capable of filtering 200,000 total computers in a network consisting of two POPs. The solution **must** be configured to support 100,000 client computers and 140,000 users using 10 gigabits/sec of band width at each POP.

The vendor must provide evidence of at least one current, successful installation of the Internet filtering solution in a network configuration servicing 100,000 computers and 140,000 users with 10 gigabits/second of Internet bandwidth. This evidence must include details regarding the size and scope of the successful project(s) as well as contact name(s) and phone number(s) for customer(s) where the successful Internet filtering solution was implemented. The vendor must submit a memo from the successful customer (on customer's letterhead, dated and signed) describing the size and scope of the successful project, as well as any issues (if any) and how they were resolved.

## Requirements Response

The filtering solution **must** be a POP based installation capable of providing a level of service appropriate for an Internet Service Provider; a filtering solution which involves the installation of filtering software or hardware within school districts or individual schools is not acceptable.

### ***CDWG Response:***

The proposed McAfee Web Gateway solution can accommodate your network design in a number of ways. The MWG controls traffic that originates from clients (including individual computers or servers) on the internal network. Typically, the web proxy is deployed between clients and the firewall where it intercepts requests for content from clients to outside web servers.

The web proxy can be configured as a transparent proxy or an explicit proxy.

The McAfee Web Gateway can leverage the Cisco-developed Web Cache Communication Protocol (WCCP). This content-routing protocol provides a mechanism to redirect traffic flows in real-time. It has built-in load balancing, scaling, fault tolerance, and service-assurance (failsafe) mechanisms. By leveraging existing Cisco infrastructure, transparent deployment of McAfee Web Gateway can be achieved with minimal effort.

When configured as a transparent proxy, an MWG appliance is invisible to client devices. Connections to the web are intercepted by WCCP on existing Cisco switches or a load balancer and redirected directly through the device. Client applications, such as web browsers, do not have to be configured to accommodate the appliance. Additionally, a transparent configuration eliminates the possibility of users reconfiguring their web browsers to bypass the appliance without the knowledge of a WVDE administrator.

When configured as an explicit proxy, an MWG appliance acts on behalf of client web browsers to handle requests to the web server.

## Requirements Response

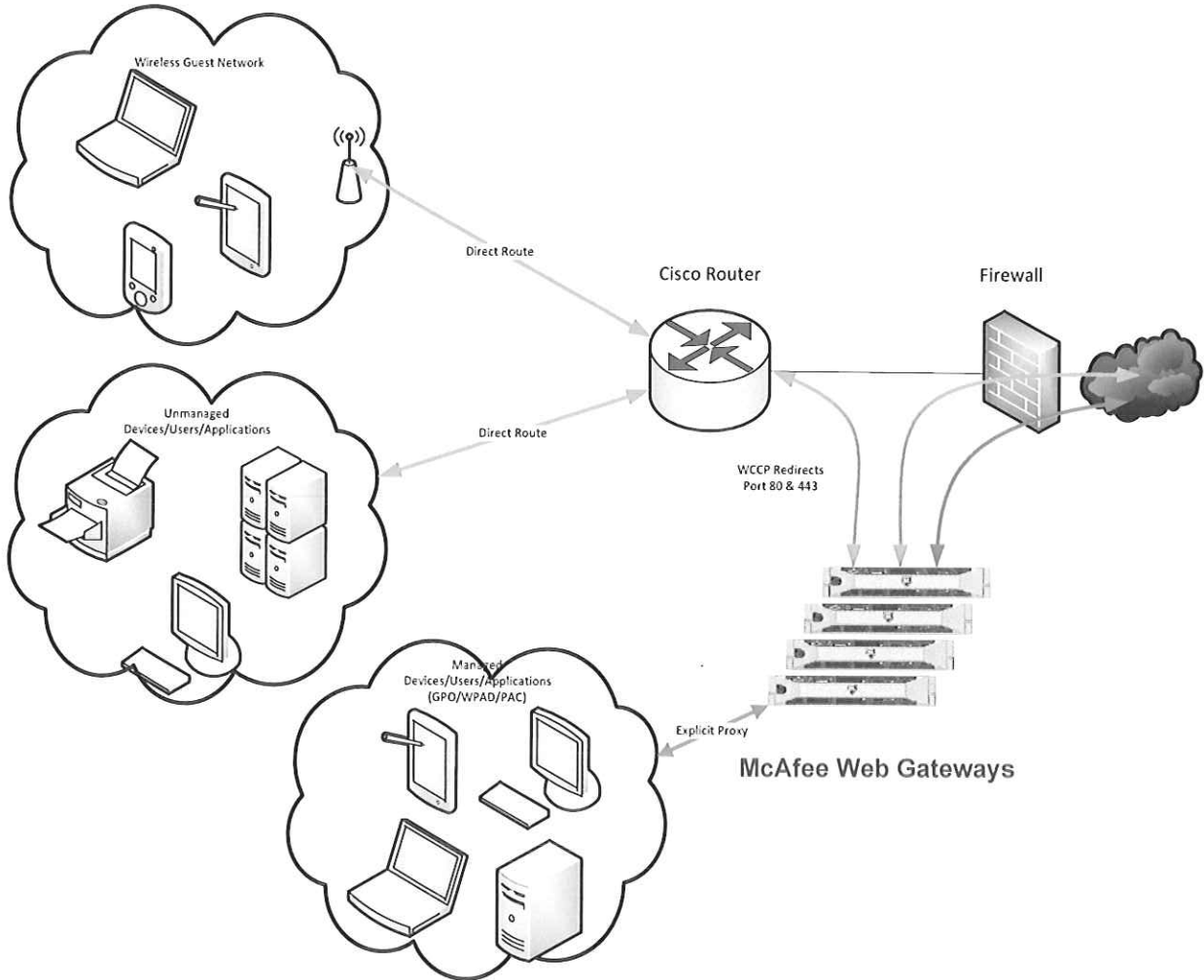

The vendor **must** provide Internet filtering and reporting application software and all necessary supporting software including, but not limited to, operating system and database software.

**CDWG Response:** (Complies)

The Internet filtering solution **must** meet the requirements of this RFQ using servers/appliances provided by the vendor or when installed on the WVDE owned equipment identified in Section I - Current Environment.

**CDWG Response:** (Complies)

The WVDE will provide server hardware, equipment racks, networking components and cabling as specified in Section I - Current Environment.

**CDWG Response:**

A complete range of enterprise- and medium-capacity appliances offers affordable protection and scalability for the most demanding environments. For WVDE, the proposed solution consists of a series of WG5500 appliances for each POP.

## Requirements Response

### Proposed System Specifications

- Model WG5500
  - Form factor: 2U rack mount
  - RAM: 12 GB
  - Processor: 2 x 6 core
  - Processor cache: 12 MB
  - Disk: 6 x 300 GB SAS
  - RAID level: Yes
  - Power supply: 2 x 750 W (hot swap)
  - Interfaces: 4 x 10/100/1000

The filtering solution must support gigabit speed, copper based, Ethernet network interfaces.

#### **CDWG Response:**

See Proposed System Specifications

The filtering solution must not exceed a total of 12 servers or appliances at each POP.

#### **CDWG Response:**

The proposed filtering solution is comprised of ten WG5500s located at each POP.

The total of all hardware components of the filtering solution for each POP must be rack mountable and not occupy more than 24 units of rack space (about 48") at each POP site. The equipment **must** operate on 110-120 Volts AC power.

#### **CDWG Response:**

Each of the ten proposed WG5500 appliances are 2U giving a total of 20U of rack space. (\*Expectation is to re-use at least 2 of the existing servers and one additional SQL server...need hardware specs. All of these servers are located in one POP, they are not split between the 2 POPs. There is one reporting system for both POPs\*)

In the event the winning bid does not meet the requirements of this RFQ when installed on vendor provided server/appliances or on the existing equipment identified in Section 1-Current Environment, the vendor **must** provide additional servers and any other associated installation, shipping, labor and configuration expenses at no cost to the WVDE or the contract will be immediately terminated.

#### **CDWG Response:** (Complies)

There must be no requirement for any configuration changes of any networking equipment or computers that are connected to the private WV K-12 network at the school districts or individual schools.

#### **CDWG Response:**

By leveraging existing Cisco infrastructure and WCCP, transparent deployment of McAfee Web Gateway can be achieved without the need to make changes on the client.

## Requirements Response

The filtering solution must provide client software which can be installed on mobile computers that will enforce the same filtering parameters whether a mobile computer is connected to the WV K-12 network or connected by wired or wireless networking to the Internet via any other Internet service provider. The client software **must** not be a VPN (virtual private networking) or similar type of client and **must** not rely on a web browser setting such as a proxy server configuration.

### **CDWG Response:**

McAfee extends web security to users working outside the local area network by redirecting web traffic from laptops to a McAfee® Web Protection solution—either McAfee SaaS Web Protection or an on-premises web gateway. McAfee redirects off-network web traffic with McAfee Client Proxy.

McAfee Client Proxy software is location-aware and recognizes its environment, whether inside the local area network, connected to it by VPN, or external to it. When inside a McAfee Web Gateway-secured network or connected by VPN, it is passive. The client software intercepts the TCP connections but lets them pass to the original destination without modifying the traffic. When outside the network, McAfee Client Proxy is active and directs traffic to the designated McAfee web protection solution, most likely McAfee SaaS Web Protection.

The filtering solution must have the capability to filter based on the IP address of the client computer and not require user authentication.

### **CDWG Response:**

#### Policy Criteria

McAfee Web Gateway has a comprehensive set of properties used to create policy. These properties are used within policy rules to describe and enforce based on any aspect of the request or response imaginable. The properties are assembled with sets of conditions to achieve the enforcement result desired.

There are hundreds of properties including but not limited to:

- URL, URL Host, URL Path, URL Parameters, URL Categories, URL Reputation, URL Geolocation
- Application Name, Application Reputation and Risk Level
- Antimalware Infection status, Antimalware Virus name
- User Name, User Groups, Authentication Domain, User Attribute looked up in LDAP or RADIUS
- Certificate status of HTTPS site
- Date/Time criteria including Month, Day, Year, Hour, Minute, Second, Day of Week, hour of Day, Minute of hour
- Any Request and Response Header information including User-Agent or Content-Type
- Any HTML Element within the body of a page
- Content Type from filename, and Ensured type from magic byte checking
- IP address, Address Ranges and Subnets or Client IP or Destination IP.

Here are some examples of using IP-based rules in different sections of the policy.

<b><u>Authenticate: Bypass Client IPRange or</u></b> <b><u>Authenticate: Bypass Destination IPRange</u></b> Client.IP is in range list <u>Authenticate: Bypass Client IPRange</u> OR URL.Destination.IP is in range list <u>Authenticate: Bypass Destination IPRange</u>
---



## Requirements Response

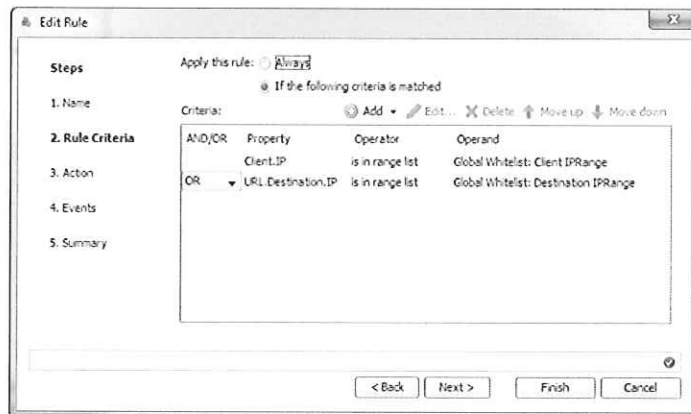

The filtering solution must have the capability to be integrated with unified authentication systems such as LDAP and Active Directory service.

### **CDWG Response:**

The McAfee Web Gateway offers multiple methods to interact and leverage Active Directory. These integration methods combined with the power of transparent authentication makes the McAfee Web Gateway a clear choice for Active Directory enabled enterprises that require group based policies. The methods outlined below are not the only available authentication options, just the ones that are used with Active Directory.

#### NTLM Integration:

The McAfee Web Gateway can join the Active Directory domain as a member workstation. The account created will be a machine account located in the computers section of active directory. By joining the domain the McAfee Web Gateway is able to transparently authenticate all users logged into the domain while they browse the web.

#### Kerberos:

Kerberos is an integral part of Active Directory implementations. The McAfee Web Gateway offers Kerberos authentication protocol which is designed to provide strong authentication for client/server applications by using secret-key cryptography. With Kerberos, the McAfee Web Gateway is able to transparently authenticate all users logged into the domain while they browse the web.

#### LDAP:

The McAfee Web Gateway can also leverage LDAP queries for username/Password verification and Group Membership. It is not possible to transparently authenticate users with LDAP.

Once authentication occurs, McAfee Web Gateway queries the directory for groups. These groups are then used in rule conditions to enforce granular policy based on user information.

The Internet filtering solution must be engineered and operate with redundancy such that the failure of one server or appliance at a POP will not reduce the capability to provide filtering for 100,000 computers and 140,000 users at 10 gigabits/sec of throughput.

## Requirements Response

### **CDWG Response:**

The single biggest factor that influences load on an MWG appliance is not Users or Bandwidth, but Requests per Second. Without actual Req/Sec metrics, we estimate that 140,000 users achieve an average of 7000 Req/Sec of high internet usage.

The proposed ten WG5500s at each POP are expected to support 140,000 high usage users for URL filtering with about 60% utilization of each after one appliance is removed from the cluster. This provides N+1 redundancy and offers room for future growth.

The filtering solution must provide a web based interface for all management and configuration tasks which can be performed by WVDE.

### **CDWG Response:**

Configuration and management of the McAfee Web Gateway is accomplished through a standard browser (Internet Explorer or Firefox) with Java Runtime Environment (JRE version 1.6 or higher) using HTTP or HTTPS (configurable). Access to the administrative GUI is controlled by forcing authentication as well as binding the Graphical User Interface to a specific IP/Network Interface.

By leveraging a standard browser for administration GUI access, the McAfee Web Gateway solution can present the same UI regardless of the platform. This simplifies upgrades to the GUI and ensures all administrators have the same version of the management application running.

The filtering solution must have the capability to be configured to block Internet access in the event of the failure of the filtering solution at a POP so that unfiltered Internet access is prevented.

### **CDWG Response:**

By using WCCP as a redirection mechanism, you have the ability to decide if you want to fail-open or fail-closed in the event of all of the appliances at a POP not being available. With the greater than N+1 sizing built into this architecture, this is never expected to happen and High Availability can be maintained.

The Internet filtering provided as a result of this RFQ **must** be verified by the vendor to meet the requirements of the Children's Internet Protection Act (CIPA) (refer to <http://www.fcc.gov/guides/childrens-internet-protection-act>) and the West Virginia Board of Education Policy 2460 that is available online at <http://wvde.state.wv.us/policies/policy.php?p=2460&alt=1>.

Specifically, CIPA states that technology protection measure (filtering solutions) must block or filter Internet access to pictures that are (a) obscene; (b) child pornography; or (c) harmful to minors. The filtering solution must block access to this CIPA specified content.

CIPA also states that schools receiving E-Rate must monitor the online activities of minors. Therefore the Internet filtering solution must include the ability to configure logging of all allowed and blocked internet requests.

### **CDWG Response:**

McAfee Web Gateway effectively blocks obscenity and material that's harmful to minors, and therefore is an excellent solution to help organizations comply with U.S. CIPA guidelines. CIPA and the FCC have left it up to schools and libraries to "map" CIPA requirements to the categories of filtering vendors. McAfee recommends that each school and library understand all categories available and apply a policy that best suits their school or community needs. Many of McAfee's customers create successful policies that rely on categories such as: Nudity, Pornography, Sexual Materials, and Extreme.

## Requirements Response

McAfee Web Gateway also offers an Exempt feature that many schools and libraries find useful when building policy for students of differing ages and needs. This feature lets users view sites that fit into a particular Exempted category, regardless of other categories they may be in that are set to Block. For example, you may want to block nudity but allow it when it is related to health or education.

The filtering solution must be verified by the vendor to comply with the Children's Online Privacy Protection Act (COPPA)(refer to <http://www.ftc.gov/ogc/coppa1.htm>). The filtering process **must** not require the collection of any personal information from any users under the age of 13.

**CDWG Response:** (Complies)

The filtering solution must provide the capability for the WVDE to selectively enable filtering of content based on categories of websites or individual websites using the http and https protocols.

**CDWG Response:**

McAfee Web Gateway is an enterprise strong proxy for HTTP, HTTPS, FTP, IM and RTSP traffic.

The vendor must include all categories that the vendor offers on the product. The vendor must not offer a reduced number of categories in an attempt to reduce costs by providing only the categories that are identified in this RFQ.

The vendor must provide, but is not limited to, the pre-populated categories of the following classifications or equivalent classifications of content on websites:

- Pornography
- Obscenity
- Dating (including sites for the purpose of establishing personal relationships)
- Gambling
- Criminal Activities (sites that condone or provide instructions for criminal activity)
- Illegal Drugs (sites that condone or provide instructions for illegal drug use, manufacturing and distribution)
- Anonymous Proxies (anonymizers to bypass filtering or hide the true source of Internet activity)
- Computer crimes, cracking and hacking (sites that condone or provide instructions for these activities)
- Malicious code (sites that contain, distribute, or execute malicious code such as malware, viruses, root kits, bots, etc or retrieve information from computers that are infected with malicious code)
- Instant messaging sites
- Peer to Peer (P2P sites)
- Phishing (fraudulent sites that imitate authentic sites, often to lure people into submitting personal or financial information.)
- Hate, racism, discrimination (sites that condone or encourage violence against or suppression of any minorities or grouping based on race, religion, sexual orientation, ethnicity or any other social grouping characteristic)

**CDWG Response:**

(pull categories out of the document here)

[http://www.trustedsource.org/download/ts\\_wd\\_reference\\_guide.pdf](http://www.trustedsource.org/download/ts_wd_reference_guide.pdf)

## Requirements Response

The filtering solution **must** have the capability to allow or deny access to any individual website, URL, or IP address whether or not it is included in any vendor provided category.

**CDWG Response:**

(See [Policy Criteria](#) above.)

The filtering solution must have the capability to permit the WVDE to create unlimited additional custom categories.

**CDWG Response:**

McAfee Web Gateway has the ability to define up to 500 custom categories. However, it is not necessary to implement custom categories to customize the sites that different groups of users are allowed to or denied from.

McAfee Web Gateway's policy consists of objects called lists. The lists can contain URLs, Sites, Regexes, IP addresses and other types that contain user-definable entries. An unlimited number of entries and an unlimited number of lists allow you to define your policy according to your needs without the need for custom categories.

The image below is a small fragment of a many thousand entry site list that are used to allow a specific class of users to go to, regardless of the category.

505	www.wolffolins.com
506	www.womenshealthmag.com
507	www.workerscompinsider.com
508	www.wsradio.com
509	www.wwe.com
510	www.yourminis.com
511	www.yvonnescatering.com
512	www2.calhospital.org
513	www5.hp.com
514	x61ppet.postx.com
515	ymcaexchange.org
516	zixmessagecenter.com
517	zoomerang.com

The filtering solution must have the capability to permit the use of "regular expressions" (includes wildcard characters and other variables to specify complex text strings) when creating custom allow or deny lists of URL web addresses or search terms.

**CDWG Response:**

McAfee Web Gateway's wildcard lists provide the ability to use regular expressions to be used in policies.

The image below shows an individual Regular Expression.

## Requirements Response

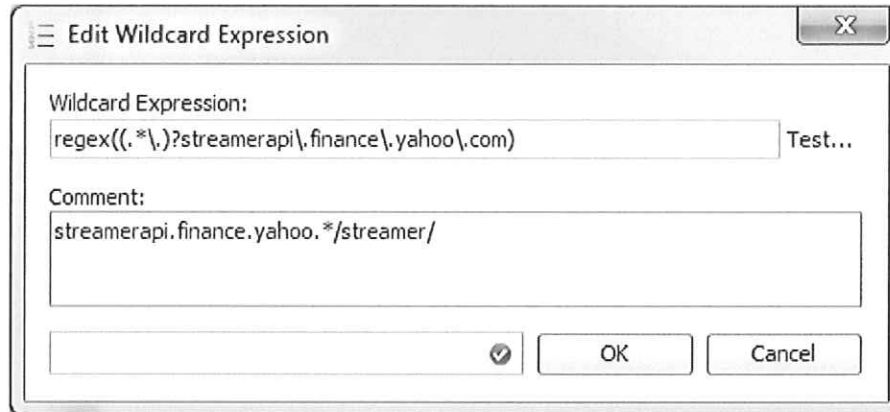

Dialog box titled "Edit Wildcard Expression".

Wildcard Expression: regex((.\*\.)?streamerapi\,finance\.yahoo\.com) Test...

Comment: streamerapi.finance.yahoo.\*/streamer/

Buttons: [Test...], [OK], [Cancel]

It also has the ability to use simplified wildcard expressions instead of the more complex regex.



Dialog box titled "Edit Wildcard Expression".

Wildcard Expression: \*.balancer[0-9]\*.netdania.com Test...

Comment: balancer[0-9]\*.netdania.\*/streamingserver/streamingserver

Buttons: [Test...], [OK], [Cancel]

The filtering solution must have the capability to block traffic related to peer-to-peer file sharing protocols.

### **CDWG Response:**

McAfee Web Gateway has the ability to identify over 1,000 individual web applications and enforce policy based on them. AppPrism has been incorporated into the McAfee Web Gateway for the discovery and control of web applications. AppPrism provides granular control of the most popular web sites down to the functional level of the site.

No.	Application Name	Comment
1	Twitter message posting	Risk: High: An web Application.
2	Twitter posting	Risk: High: A social networking site
3	Box.net editing	Risk: High: A feature of a file-sharing website
4	Box.net uploading	Risk: High: A file-sharing website
5	Facebook Applications (Facebook Apps)	Risk: High: A web application
6	Facebook Chat	Risk: High: A chat web application by Facebook.
7	Facebook Create Group	Risk: Minimal: A web-based Group in Facebook.
8	Facebook Mail	Risk: High: A web based email application
9	Facebook Photo Upload	Risk: High: A Photo sharing web application by Facebook.
10	Facebook Posting	Risk: High: A web application
11	Facebook Social Plugins	Risk: High: A social networking site
12	Facebook Video Upload	Risk: High: A Video sharing web application by Facebook.
13	LinkedIn App	Risk: High: A business-oriented social networking website
14	LinkedIn Mail	Risk: Minimal: A web based email application
15	LinkedIn Post	Risk: High: A business-oriented social networking website
16	Facebook Create Page	Risk: Minimal: A web-based fan page service

## Requirements Response

Among those applications is the control of Peer to Peer applications:

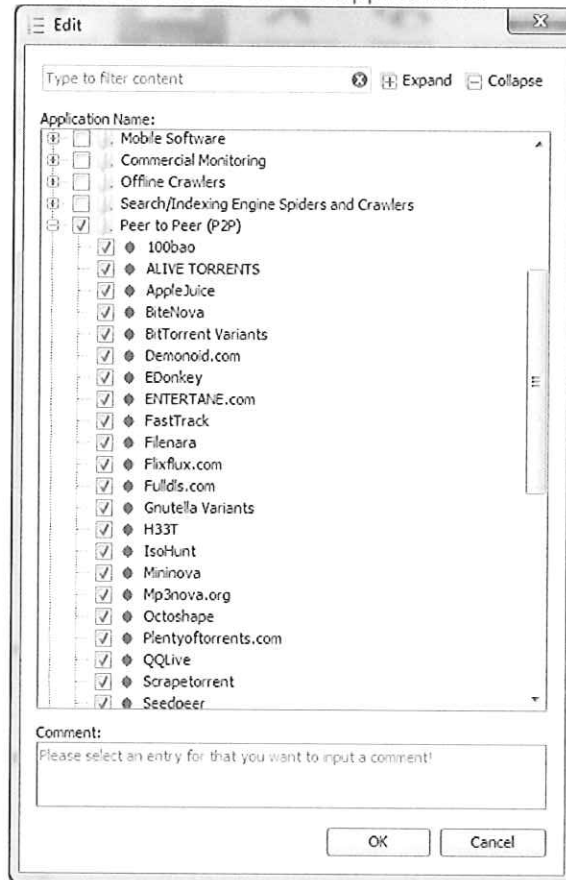

The filtering solution must have the capability to enforce the "safe searching" mode of Google, Bing and Yahoo search engines, regardless of the settings chosen by an end user that is using those search engines.

### **CDWG Response:**

McAfee Web Gateway has SafeSearch Enforcer which overrides the individual settings a user on most of the popular search engines.

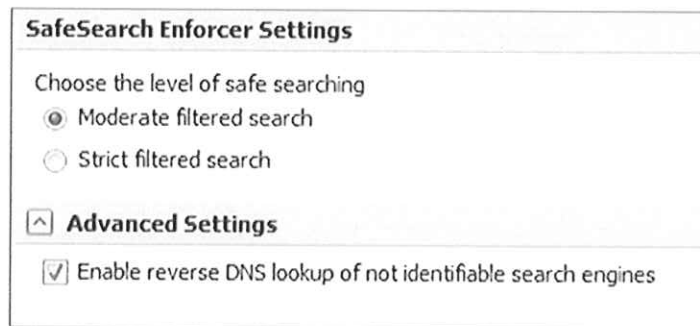

The filtering solution must provide capabilities to create manageable client groups based on IP address ranges and assign names to those groups.

### **CDWG Response:**

## Requirements Response

McAfee Web Gateway's IP and IP Range list types allow the administrator to maintain their own list of IP addresses used for policy.

Below are images of IP Range lists, IP lists, and some policy rules that may use them.

No.	IPRange	Comment
1	64.68.96.0/19	US Production IP exceptions (CIDR)
2	66.114.160.0/20	US Production IP exceptions (CIDR)
3	66.163.32.0/20	US Production IP exceptions (CIDR)
4	209.197.192.0/19	US Production IP exceptions (CIDR)
5	210.4.192.0/20	Outside of the USA (CIDR)
6	62.109.192.0/20	Outside of the USA (CIDR)
7	208.8.81.0/24	Addition server exception (CIDR)
8	114.29.192.0/19	Production IP exception India (CIDR)
9	173.243.0.0/20	Additional server exception (CIDR)

No.	IP	Corr
1	172.16.0.3	
2	172.16.0.5	
3	10.1.2.3	
4	10.0.0.11	

<p><b>SSL Tunnel: Client IPRange<sup>1</sup> or SSL Tunnel: Destination IPRange<sup>1</sup></b>            Client.IP is in range list <u>SSL Tunnel: Client IPRange<sup>1</sup></u> OR            URL.Destination.IP is in range list <u>SSL Tunnel: Destination IPRange<sup>1</sup></u></p>
<p><b>SSL Tunnel: Webex IP Ranges</b>            URL.Destination.IP is in range list <u>WebEx IP Ranges</u></p>
<p><b>SSL Tunnel: Citrix IP Ranges</b>            URL.Destination.IP is in range list <u>Citrix IP Ranges</u></p>

The capability must exist to delegate management of groups by creating additional administrators with restricted rights who can be assigned to manage filtering parameters for specific groups.

### **CDWG Response:**

McAfee Web Gateway has the ability to define administrative roles that authorize access to different features of the system. These roles are assigned to administrative accounts or groups that authorize access only to designated areas.

These roles can be applied to every policy object. The choice of "Read and Write", "Read Only" and "No Permission" can be applied to Rule Sets, Lists and Settings. This combination of roles and permissions makes McAfee's role-based management extremely granular and provides the administrator the ability to delegate specific functions securely.

The following screenshot illustrates the different roles that can be associated to an administrative account. The "Edit List" screenshot illustrates the permissions applied to the specific role for a managed Whitelist.

## Requirements Response

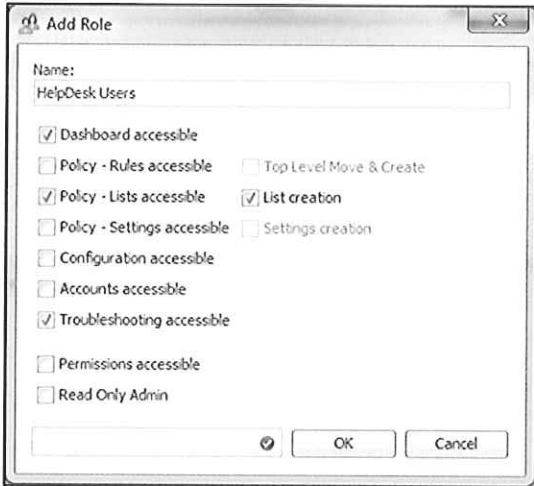

The broadness and granularity of the McAfee Web Gateway's role-based management simplifies the challenge of managing large networks and reduces the complexity of security administration.

The filtering solution must provide for customizable, granular permissions so that additional administrator/user accounts can be tailored on a user by user basis to match the rights of a user to the tasks that a user needs to perform.

### ***CDWG Response:***

In addition to the role assignments to users, each policy element has access control to that element. This provides the ability for a specific authorized administrator to only view or modify the specific objects within the policy they are permitted access to.

This image shows a view of the policy by the Super Administrator with full permissions.



# Requirements Response

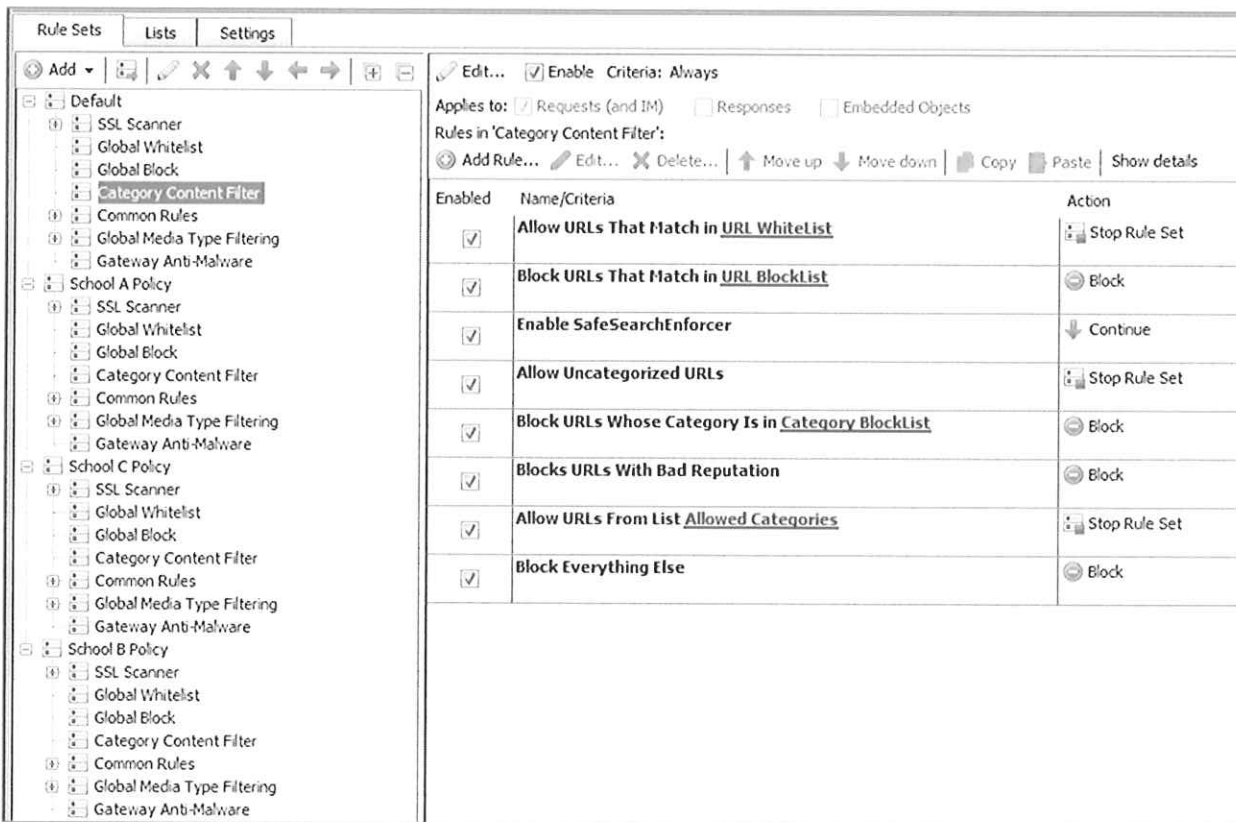

This image shows a restricted view of the policy by a restricted administrator only allowed to edit School A's policy.

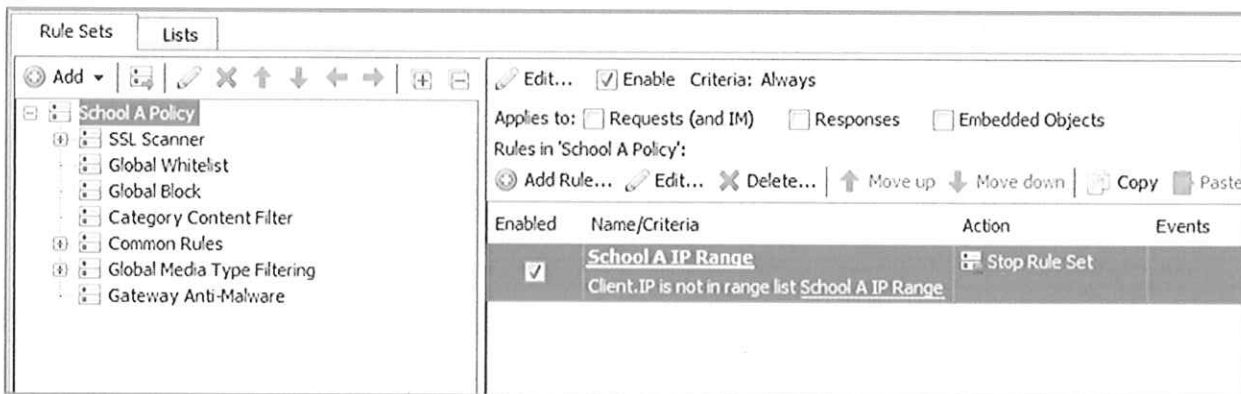

The filtering solution must have the capability to selectively display WVDE customized "site blocked" pages based on the client group and/or the categorization of the blocked website.

**CDWG Response:**

As policy is enforced, the administrator can decide how little or how much information is supplied to the user in order aid in the user-awareness and explain why a block occurred.

## Requirements Response

By default, simple HTML templates are provided that give basic information about the reason a site was blocked. Each template can be customized to include as much information as the administrator desires using the built-in template editor.

The following screenshot shows the template editor for customization of block templates.

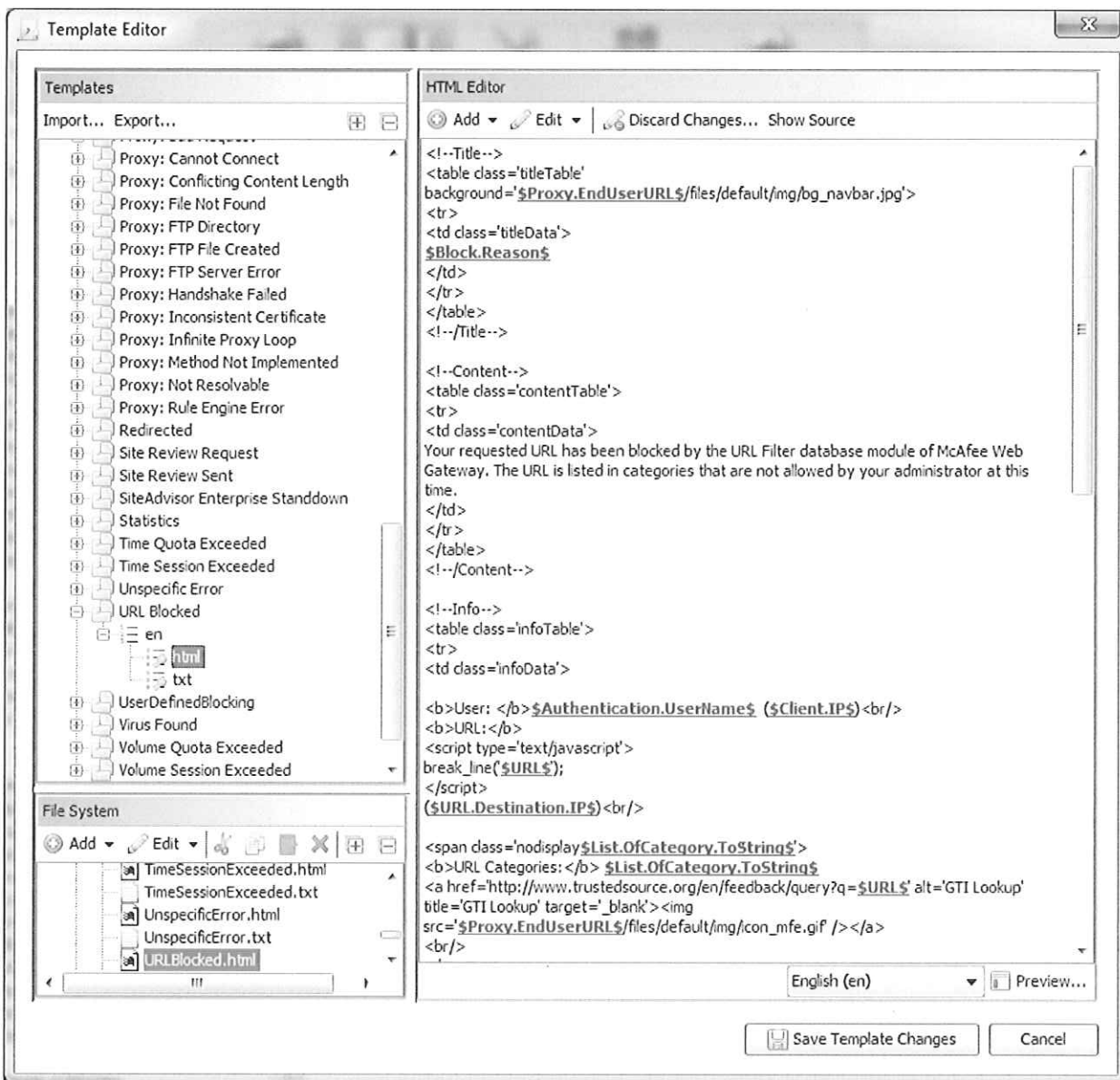

The following screenshot shows the default URL filtering block page:

# Requirements Response

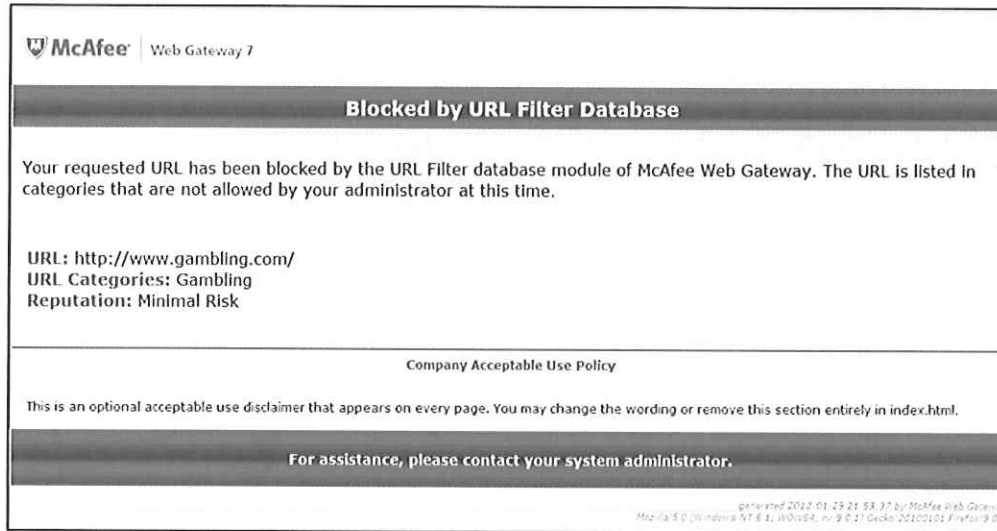

**McAfee** | Web Gateway 7

### Blocked by URL Filter Database

Your requested URL has been blocked by the URL Filter database module of McAfee Web Gateway. The URL is listed in categories that are not allowed by your administrator at this time.

**URL:** http://www.gambling.com/  
**URL Categories:** Gambling  
**Reputation:** Minimal Risk

---

**Company Acceptable Use Policy**

This is an optional acceptable use disclaimer that appears on every page. You may change the wording or remove this section entirely in index.html.

**For assistance, please contact your system administrator.**

generated 2012-01-29 21:53:37 by McAfee Web Gateway  
Mozilla/5.0 (Windows NT 6.1; WOW64; rv:9.0.1) Gecko/20100101 Firefox/9.0.1

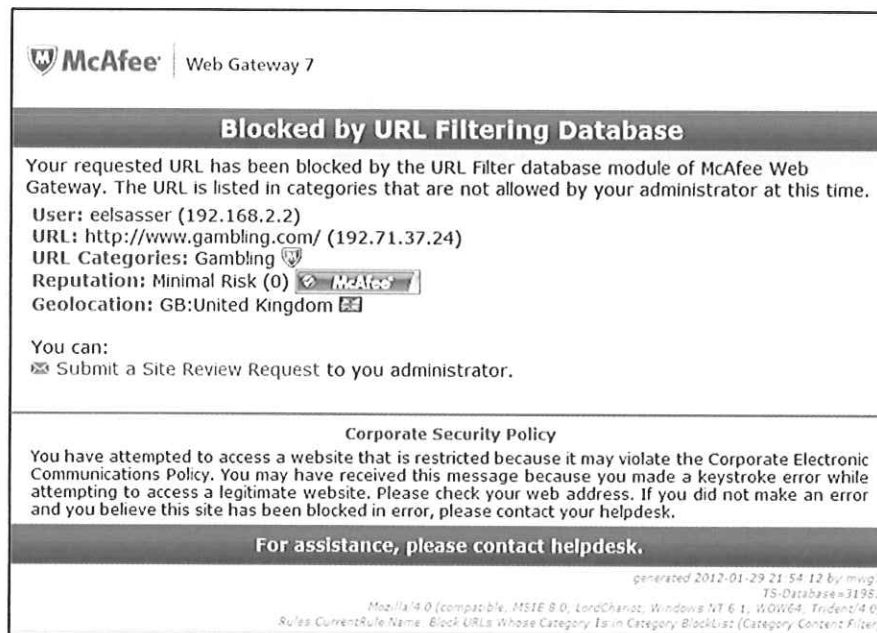

The following screenshot shows a detailed variation of the default block page.



**McAfee** | Web Gateway 7

### Blocked by URL Filtering Database

Your requested URL has been blocked by the URL Filter database module of McAfee Web Gateway. The URL is listed in categories that are not allowed by your administrator at this time.

**User:** eelsasser (192.168.2.2)  
**URL:** http://www.gambling.com/ (192.71.37.24)  
**URL Categories:** Gambling  
**Reputation:** Minimal Risk (0)   
**Geolocation:** GB:United Kingdom 

**You can:**

- Submit a Site Review Request to your administrator.

---

**Corporate Security Policy**

You have attempted to access a website that is restricted because it may violate the Corporate Electronic Communications Policy. You may have received this message because you made a keystroke error while attempting to access a legitimate website. Please check your web address. If you did not make an error and you believe this site has been blocked in error, please contact your helpdesk.

**For assistance, please contact helpdesk.**

generated 2012-01-29 21:54:12 by mg7  
IS-Database=31981  
Mozilla/4.0 (compatible; MSIE 8.0; LordOfTheNet; Windows NT 6.1; WOW64; Trident/4.0)  
Rules CurrentRuleName: Block URLs Whose Category Is in Category BlockList (Category Content Filter)

The following screenshot shows how one customer has highly customized their block pages for their users:

## Requirements Response



Block pages are the primary communication method to a user when something has been blocked. They can be designed to explain why the block occurred, give detailed information about the connection, allow for submission of a site review to the help desk, and remind users of the company policy.

The filtering solution must have the capability to selectively display WVDE customized "informational" pages based on the client group and/or the categorization of websites to which access is allowed.

***CDWG Response:***

Coaching can display a warning page with information when a user requests access to a web site. It is then the user's responsibility to decide whether to click through to access the access the web site or not.

# Requirements Response

 Web Gateway 7

---

**Coaching Session**

If you want to continue the session please confirm by clicking the "Continue Session" button.

User: eelsasser (192.168.2.2)  
URL: http://www.angrybirdsnest.com/ (173.199.131.155)  
URL Categories: Games  
Reputation: Minimal Risk (0) 

---

Please confirm:

---

**Sample Internet Usage Policy**

This Sample Internet Usage Policy applies to all employees of <company> who have access to computers and the Internet to be used in the performance of their work. Use of the Internet by employees of <company> is permitted and encouraged where such use supports the goals and objectives of the business. However, access to the Internet through <company> is a privilege and all employees must adhere to the policies concerning Computer, Email and Internet usage. Violation of these policies could result in disciplinary and/or legal action leading up to and including termination of employment. Employees may also be held personally liable for damages caused by any violations of this policy. All employees are required to acknowledge receipt and confirm that they have understood and agree to abide by the rules hereunder on a periodic basis.  
(This is an optional acceptable use disclaimer that appears on every page. You may change the wording or remove this section entirely in index.html.)

---

**For assistance, please contact your helpdesk.**

---

generated 2013-06-06 22:45:36 by mwg7 (7.3.2)  
(AM-DAT=1872)AM-Engine=7001.1202.1802|MFE-DAT=7098|MFE-Engine=5400.5001|TS-Database=40258)  
Mozilla/5.0 (Windows NT 6.1; WOW64; rv:21.0) Gecko/20100101 Firefox/21.0  
Rules CurrentRule Name: Check If Coaching Session Has Been Exceeded(Coaching With URL Configuration)

Authorized Override is way for users to get blocked from a site, but be overridden by a username and password. One Time Passwords can also be configured for use with Authorized Override.

## Requirements Response

 Web Gateway 7

---

**Authorized Override Session**

If you want to continue the authorized override session please enter your login and password and confirm with pushing the button "Temporarily Override Filtering".

User: eelsasser (192.168.2.2)  
URL: http://www.bluesnews.com/ (216.45.58.170)  
URL Categories: Games  
Reputation: Minimal Risk (0) 

---

**Authorized Override**

User Name:   
Password:   
Session Length (in Minutes):   
Please confirm:

---

**Sample Internet Usage Policy**

This Sample Internet Usage Policy applies to all employees of <company> who have access to computers and the Internet to be used in the performance of their work. Use of the Internet by employees of <company> is permitted and encouraged where such use supports the goals and objectives of the business. However, access to the Internet through <company> is a privilege and all employees must adhere to the policies concerning Computer, Email and Internet usage. Violation of these policies could result in disciplinary and/or legal action leading up to and including termination of employment. Employees may also be held personally liable for damages caused by any violations of this policy. All employees are required to acknowledge receipt and confirm that they have understood and agree to abide by the rules hereunder on a periodic basis.  
(This is an optional acceptable use disclaimer that appears on every page. You may change the wording or remove this section entirely in index.html.)

---

**For assistance, please contact your helpdesk.**

generated 2013-06-06 22:54:15 by: msig7 (7.3.2)  
(AM-DAT=1872;AM-Engine=7001.1202.1802;MFE-DAT=7098;MFE-Engine=5400.5001)TS-Database=40258)  
Mozilla/5.0 (Windows NT 6.1; WOW64; rv:21.0) Gecko/20100101 Firefox/21.0  
Rules.CurrentRuleName: Check If AuthOverride Session Has Been Exceeded(Authorized Override With URL Configuration)

The filtering solution must have the capability to be configured to only perform filtering of outgoing requests and to perform no filtering of incoming traffic.

### **CDWG Response:**

McAfee Web Gateway delivers comprehensive security for all aspects of web traffic, regardless of location or device. For user-initiated web requests, McAfee Web Gateway first enforces an organization's Internet use policy. For all allowed traffic, it then uses multiple real-time techniques to analyze the nature and intent of all content and active code entering the network via the requested web pages, providing immediate protection against malware and other hidden threats. Unlike basic packet inspection techniques, McAfee Web Gateway can even examine SSL traffic to provide in-depth protection against malicious code that has been disguised through encryption.

To secure outbound traffic, McAfee Web Gateway scans user-generated content on all key web protocols—including HTTP, HTTPS, and FTP. Integrated data loss prevention helps prevent against loss of confidential information and other threats leaking from the organization through social networking sites, blogs, wikis, and applications. McAfee Web Gateway also safeguards against unauthorized data leaving the organization through "botinfected" machines attempting to phone home or transmit sensitive data.

In today's Web 2.0 world URL filtering alone is not enough effectively prevent access to inappropriate and malicious content. Filtering of responses can be selectively turned off at the discretion of WVDE, but in doing so you open a variety of holes in you network that cannot be closed with URL filtering alone.

## Requirements Response

The product offered by the vendor must perform Internet filtering primarily by comparing outgoing requests to a database of categorized URLs and IP addresses to determine whether an attempt to access a site on the Internet is to be blocked or permitted.

***CDWG Response:***

McAfee Web Gateway delivers enhanced web filtering functionality and protection through the powerful combination of both reputation and category-based filtering. McAfee Global GTI powers McAfee Web Gateway's web filtering technologies. McAfee GTI creates a profile of all Internet entities— websites, email, and IP addresses— based on hundreds of different attributes gathered from the massive, global data collection capabilities of McAfee Labs. It then assigns a reputation score based on the security risk posed, enabling administrators to apply very granular rules about what to permit or deny. McAfee Web Gateway offers expanded, cloud-based web reputation capabilities that include geo-location, enabling geographic visibility and policy management based on the web traffic's originating country.

For both web categorization and security-focused web reputation, organizations can choose between on-premises and cloud look-ups or a combination of both. Cloud look-ups eliminate protection gaps between discovery/change and system updates and offer significantly enhanced coverage with data on more than 140 million URLs.

Any other Internet filtering methods of the filtering solution, such as "on the fly" evaluation of incoming content, must be able to be selectively disabled at the option of the WVDE.

***CDWG Response:***

For uncategorized URLs, McAfee Web Gateway offers local, dynamic content classification. By using advanced algorithms, it can analyze content and assign a category in real time. However Dynamic can be selectively disabled and WVDE's discretion.

The filtering solution must provide a web based display of status and performance graphs for all components of the filtering solution.

***CDWG Response:***

The McAfee Web Gateway's dashboards contain a quick look at the operational status of the appliance. Information contained in the dashboards includes:

- System Alerts
- Executive Summary
- Web Traffic Summary
- ICAP Traffic Summary
- IM Traffic Summary
- General Traffic Summary
- Web Cache Statistics
- Malware Statistics
- URL Filter Statistics
- Media type Statistics
- Certificate Statistics
- System Details
- Authentication Statistics
- Performance Information

# Requirements Response

The graphs are customizable in their ability to select a time-series granularity from one hour to one year of history and data is selectable by type of statistic displayed. The dashboards for all the nodes in a cluster can be viewed from one console.

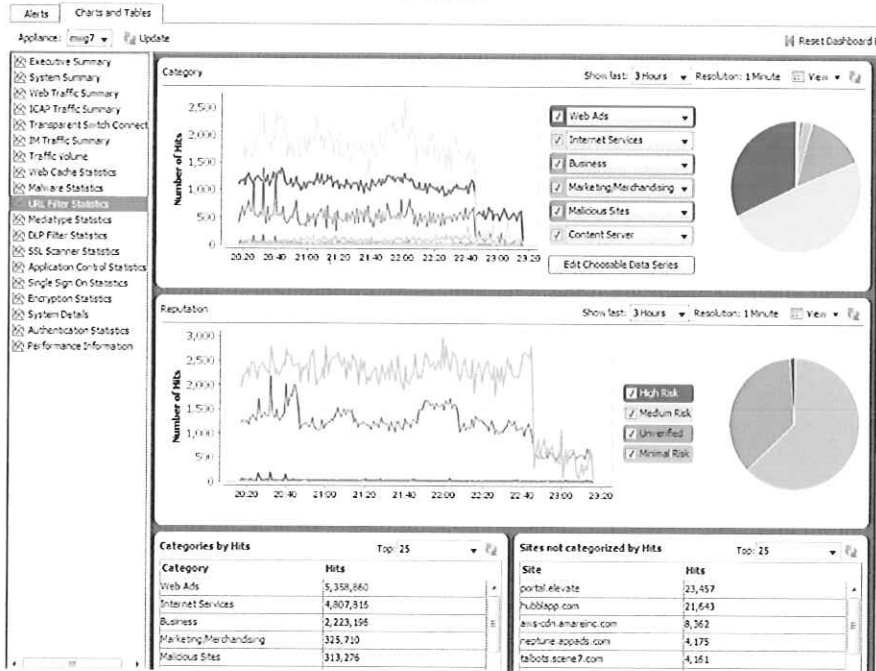

The filtering solution must have the capability for the WVDE to set customized filtering policies based on the time of day and the day of the week for individual IP addresses and/or groups of client IP addresses.

## CDWG Response:

(See Policy Criteria Above)

The following image shows an example policy rule by time of day.

Name/Criteria
<b>10:00-10:20</b>
DateTime.Time.Hour equals 10 AND DateTime.Time.Minute less than or equals 20
<b>12:30-13:30</b>
(DateTime.Time.Hour equals 12 AND DateTime.Time.Minute greater than or equals 30) OR ( DateTime.Time.Hour equals 13 AND DateTime.Time.Minute less than or equals 30)
<b>Block All Other Times</b>
Always

The Internet filtering solution must not masquerade, spoof or change the source IP address of the computers on the K-12 network. The source IP address of the client computer must be passed to the PIX firewall.



## Requirements Response

### **CDWG Response:**

McAfee Web Gateway has an IP spoofing feature, when used in conjunction with WCCP, will retain the original Client IP address coming from the proxies and pass that to the firewall.

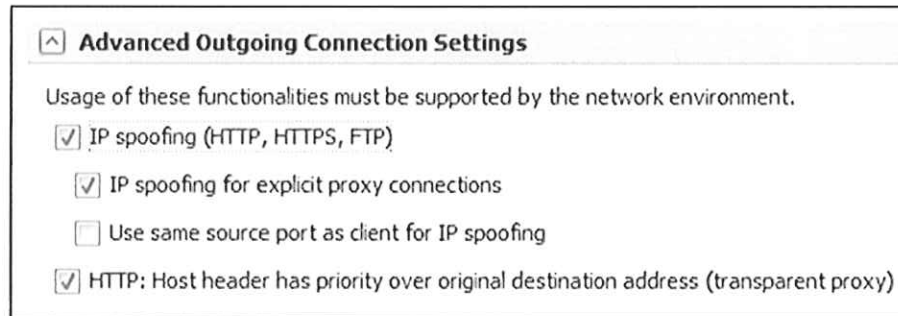

The Internet filtering and reporting servers must operate on and report on the 10.0.0.0 private network IP addresses of the WVDE K-12 network.

### **CDWG Response:** (Complies)

The filtering solution must have a synchronization capability. Synchronization means that when the WVDE makes a filtering configuration change using the web management tool, that change will be distributed to all of the filtering servers at both POPs. That change distribution must take effect automatically within 5 minutes after the act of saving of the configuration change, or be accomplished manually with no more than 5 mouse clicks after the configuration change is saved.

### **CDWG Response:**

Multiple McAfee Web Gateways can be centrally managed through the built in Central Management facility included on all appliances. The appliances (nodes) are joined in a user defined group that allows, for example, updates from one appliance to be propagated to other appliances. A node can also be a member of multiple groups.

Additional hardware or software is not required to centrally manage multiple McAfee Web Gateways. The central management function is incorporated into each appliance, allowing management of all appliances to be accomplished through one web-based GUI. This feature is provided at no additional cost to the user.

The diagram below shows a group of appliances in a Central Management configuration.

## Requirements Response

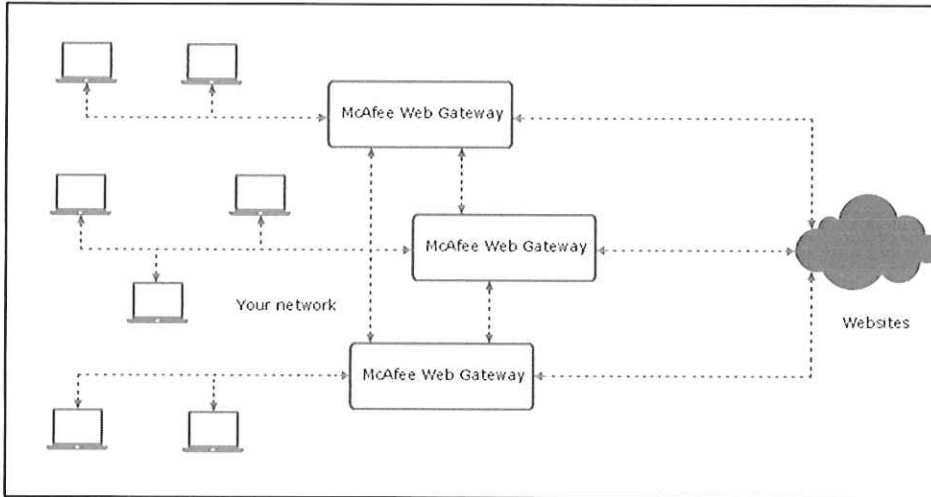

The following screenshot illustrates the administrator adding another McAfee Web Gateway appliance to a specified "Network Group" cluster

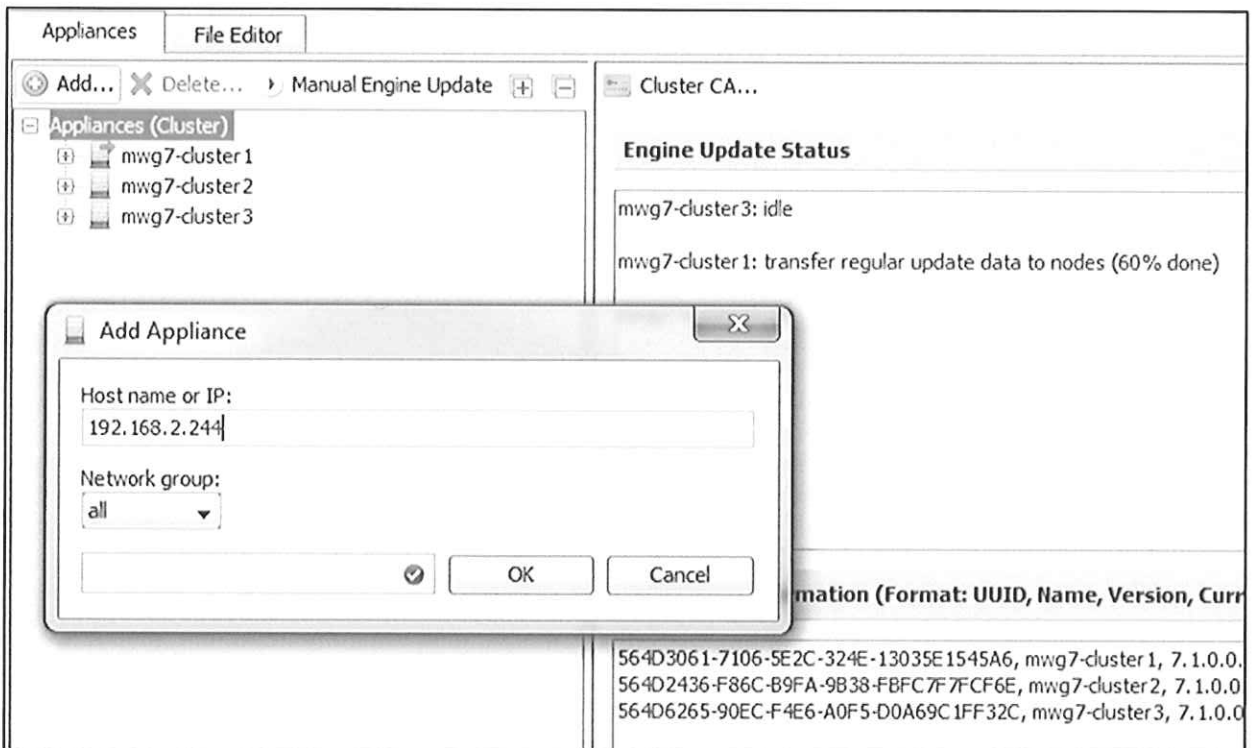

Using the same GUI to centrally manage all Web Gateway appliances (without the need of a separate management appliance) simplifies the administrator's learning curve and reduces overall power consumption in the data center.

### Internet Use Reporting

The filtering solution must provide a web-based reporting application and a minimum of one terabyte of log file storage at each POP.

## Requirements Response

### **CDWG Response:**

(This depends on the server speced for Web Reporter. 5 TB minimum to handle the database and 1TB of stored historical logs.)

The filtering solution must provide a method for the WVDE to download log files in a generic text format for analysis and archival storage.

### **CDWG Response:**

#### **McAfee Web Gateway Logging**

McAfee Web Gateway also provides the user with the ability to define his own log files from the GUI. By default, three user-defined log files are created:

- Access log: log file that records requests and related information, including date and time, user name, requested object, infection of an object, blocking of an object.
- Access\_denied.log: log file that records all policy violations that resulted in blocked content.
- Found viruses log: log file that records the names of viruses and other malware that were found to infect requested objects. Also records date and time, user name, IP address of the client the request was sent from and requested URL.

Logs are directly viewable and downloadable for the GUI.

The Log Handler engine provides the flexibility to log any available piece of information related to a web request using any conditions. Administrators will commonly create their own access logs for only blocked events, or an isolated test log that only records traffic for a particular user, IP or web site for troubleshooting.

Some creative examples customers have reported doing include:

- Logging of YouTube video titles.
- Logging for Search Engine terms in a request
- Logging of filenames uploaded to a web site.
- Write user information anonymously (encrypted) to a log file.
- Log Common Names of SSL certificates when traffic is decrypted.

The McAfee Web Gateway provides access to the following system log files from the GUI:

- Audit logs: log files that record changes to the appliance configuration.
- Debug logs:
  - Connection Tracing
  - Cores
  - Feedback Files
  - Message Tracing
  - Rule Engine Tracing
  - tcpdump
- Migration logs: log files detailing events that occur when applying system updates.
- Error logs: log files that record errors which occur in appliance components.
  - MWG - Antimalware
  - MWG - Coordinator
  - MWG - Core

## Requirements Response

- MWG - User Interface
- MWG - System Configuration Daemon
- Scheduled Jobs log: Results of automated processes such as scheduled configuration backup.
- System logs: all the log files in /var/log/ that are used by Syslog
- Update logs: log files that record updates of modules and files on the appliance.

Complete details of web browsing activity must be stored in log files and must include, at a minimum, the complete URL, date and time and IP address of the client computer.

### CDWG Response:

(See [McAfee Web Gateway Logging](#) above)

An example of a typical Access Log.



```
#time_stamp auth_user src_ip server_ip time_taken status_code cache_status req_line categories rep_level media_type bytes_to_client bytes_received
[07/Jun/2013:00:00:04 -0400] "-" 192.210.58.72 68.67.159.194 24 403 TCP_MISS "GET http://ib.adnxs.com/ttj?id=1361450&size=300x250&referrer=$(REI"
[07/Jun/2013:00:00:04 -0400] "-" 173.208.16.92 98.139.225.42 103 403 TCP_MISS "GET http://ad.globe7.com/st?ad_type=iframe&ad_size=300x250&secti"
[07/Jun/2013:00:00:04 -0400] "-" 63.141.254.68 68.67.159.194 140 403 TCP_MISS "GET http://ib.adnxs.com/ttj?id=1264851 HTTP/1.1" "Web Ad" "Unve"
[07/Jun/2013:00:00:04 -0400] "-" 74.91.27.126 98.139.225.43 47 403 TCP_MISS "GET http://ad.yieldmanager.com/imp?z=300x250&u=financysu.com&s=3986"
[07/Jun/2013:00:00:04 -0400] "-" 198.136.26.20 98.139.225.43 360 403 TCP_MISS "GET http://ad.tagjunction.com/st?ad_type=ad&ad_size=300x250&sect"
[07/Jun/2013:00:00:04 -0400] "-" 192.210.58.72 68.67.159.194 66 403 TCP_MISS "GET http://ib.adnxs.com/ttj?id=1361450&size=300x250&referrer=$(REI"
[07/Jun/2013:00:00:04 -0400] "-" 69.162.97.236 209.202.235.25 77 403 TCP_MISS "GET http://adsl.ministerial5.com/creative/2-002134559-000011;size"
[07/Jun/2013:00:00:04 -0400] "-" 198.2.192.179 68.67.159.194 132 403 TCP_MISS "GET http://ib.adnxs.com/ttj?id=1318409&size=728x90&referrer=[REFI"
[07/Jun/2013:00:00:04 -0400] "-" 192.184.47.86 199.83.132.50 146 200 TCP_MISS_RELOAD "GET http://tag1.z5x.net/5250/an/?id=1412445&size=300x250"
[07/Jun/2013:00:00:04 -0400] "-" 192.184.48.148 68.67.159.194 108 403 TCP_MISS "GET http://ib.adnxs.com/ttj?id=1218027&size=300x250 HTTP/1.1" "I"
[07/Jun/2013:00:00:04 -0400] "-" 74.91.27.126 98.139.225.43 745 403 TCP_MISS "GET http://ad.yieldmanager.com/imp?z=300x250&u=financysu.com&s=398"
[07/Jun/2013:00:00:04 -0400] "-" 221.215.112.238 66.119.66.171 210 200 TCP_MISS_RELOAD "GET http://www.mmadsadgadget.com/?id=0b5c73ba-4fe2-9064-"
[07/Jun/2013:00:00:04 -0400] "-" 192.184.47.84 68.67.159.223 246 302 TCP_MISS_RELOAD "GET http://an.z5x.net/ttj?id=1412445&size=300x250 HTTP/1."
[07/Jun/2013:00:00:05 -0400] "-" 221.215.112.238 63.215.202.6 572 200 TCP_MISS_RELOAD "GET http://media.fastclick.net/w/get.media?id=69445&tp="
[07/Jun/2013:00:00:05 -0400] "-" 221.215.112.238 66.119.66.171 333 200 TCP_MISS_RELOAD "GET http://www.mmadsadgadget.com/?id=7a42e738-dbe9-af44-"
[07/Jun/2013:00:00:05 -0400] "-" 221.215.112.238 66.119.66.171 270 200 TCP_MISS_RELOAD "GET http://www.mmadsadgadget.com/?id=9214ce46-9260-405f-"
[07/Jun/2013:00:00:05 -0400] "-" 221.215.112.238 66.119.66.171 247 200 TCP_MISS_RELOAD "GET http://www.mmadsadgadget.com/?id=3719b242-efe9-4504-"
[07/Jun/2013:00:00:05 -0400] "-" 74.91.27.126 98.139.225.42 102 200 TCP_MISS_RELOAD "GET http://ad.adorika.com/st?ad_type=ad&ad_size=300x250&se"
[07/Jun/2013:00:00:05 -0400] "-" 64.31.43.137 98.139.225.43 42 403 TCP_MISS "GET http://ads.creative-online-media.com/st?ad_type=ppcf&ad_size=0x06"
[07/Jun/2013:00:00:05 -0400] "-" 192.210.58.68 68.67.159.194 11 403 TCP_MISS "GET http://ib.adnxs.com/ttj?id=1361450&size=300x250&referrer=$(REI"
[07/Jun/2013:00:00:05 -0400] "-" 192.184.47.82 199.83.132.50 115 200 TCP_MISS_RELOAD "GET http://tag1.z5x.net/5250/an/?id=1412445&size=300x250"
[07/Jun/2013:00:00:05 -0400] "-" 198.204.252.212 98.139.225.43 45 403 TCP_MISS "GET http://ad.yieldmanager.com/st?ad_type=iframe&ad_size=300x25"
[07/Jun/2013:00:00:05 -0400] "-" 198.200.50.10 68.67.159.194 66 403 TCP_MISS "GET http://ib.adnxs.com/ttj?id=1294263&size=728x90 HTTP/1.1" "Web"
```

All end user functions of the reporting application must be accessible via a web interface.

### CDWG Response:

(See [McAfee Web Gateway Logging](#) above)

The reporting solution must provide the capability to create reports based on specific IP address, website address, date and time of day.

### CDWG Response:

The reporting solution provides interactive access to the data in the reports through dashboards and drill-downs.

# Requirements Response

At a high-level summarized data is aggregated in charts for easy viewing.

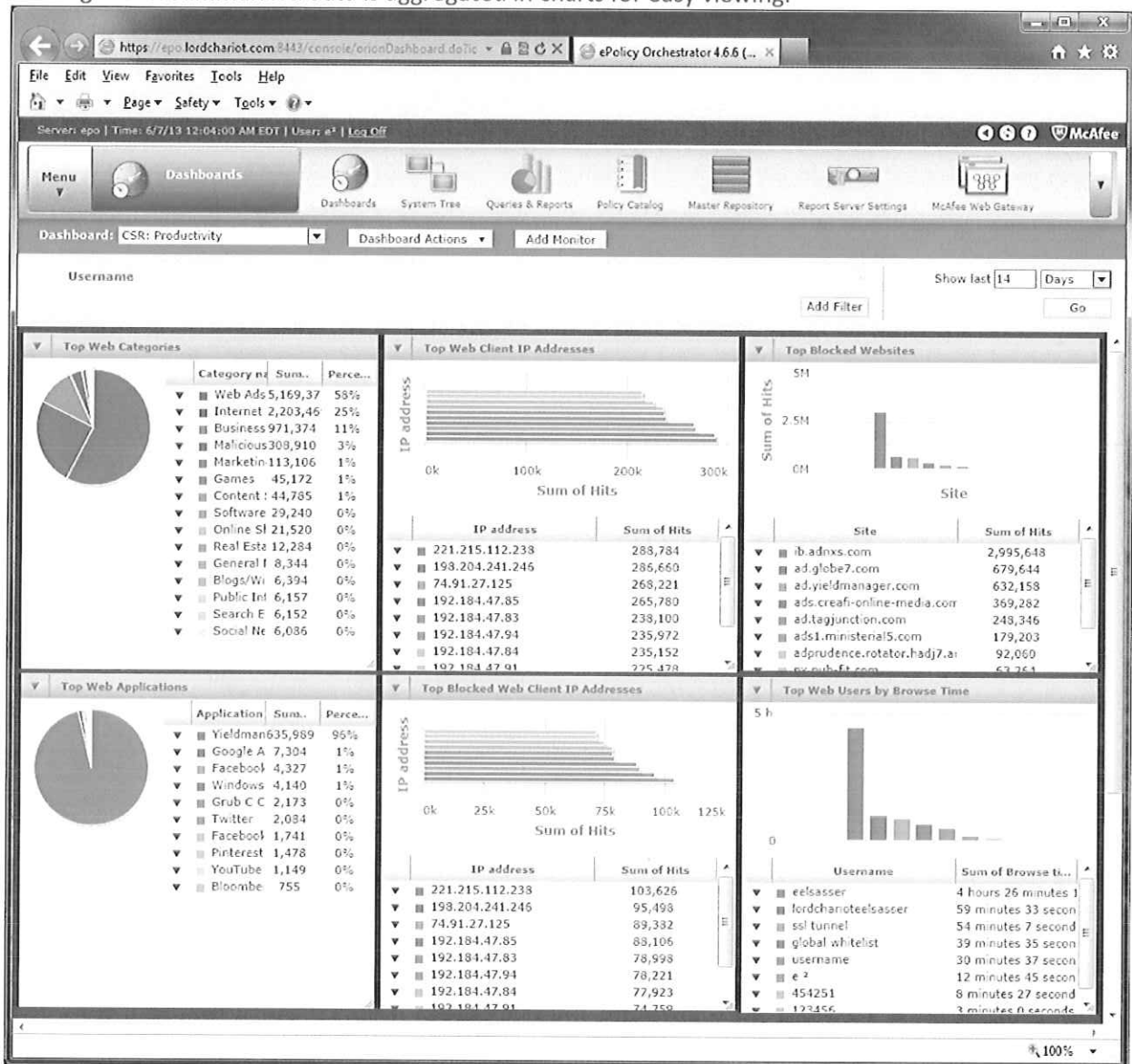

Selection criteria can be applied the dashboard view interactively to select the specific filter you want to see, and further drilldown can provide detail of the activity aggregated by the field you are selecting.

# Requirements Response

Top Web Users by Browse Time -> eelsasser Hide Filter

Custom: None Show selected rows

<input type="checkbox"/>	Date and ti...	Action taken	IP address	Username	Site	Category name	Application name	Hits	Browse time
<input type="checkbox"/>	5/24/13 1:00:00 PM	Allow	192.168.2.2	eelsasser	translate.google.co	Text Translators	Google Translate	1	0 seconds
<input type="checkbox"/>	5/24/13 1:00:00 PM	Allow	192.168.2.2	eelsasser	translate.google.co	Text Translators	Google Translate	1	0 seconds
<input type="checkbox"/>	5/24/13 1:00:00 PM	Allow	192.168.2.2	eelsasser	translate.google.co	Text Translators	Google Translate	15	39 seconds
<input type="checkbox"/>	5/24/13 1:00:00 PM	Allow	192.168.2.2	eelsasser	translate.google.co	Text Translators	Google Translate	7	1 second
<input type="checkbox"/>	5/24/13 1:00:00 PM	Allow	192.168.2.2	eelsasser	sse.bay03.calendar.	Interactive Web App	-	3	3 seconds
<input type="checkbox"/>	5/24/13 1:00:00 PM	Allow	192.168.2.2	eelsasser	co126ds.mail.servic	Web Mail	-	9	6 minutes 36 secon
<input type="checkbox"/>	5/24/13 1:00:00 PM	Allow	192.168.2.2	eelsasser	by176ds.mail.servic	Web Mail	-	9	0 seconds
<input type="checkbox"/>	5/24/13 1:00:00 PM	Allow	192.168.2.2	eelsasser	contacts.msn.com	Web Mail	-	6	0 seconds
<input type="checkbox"/>	5/24/13 1:00:00 PM	Allow	192.168.2.2	eelsasser	meta.wikimedia.org	Blogs/Wiki	-	2	0 seconds
<input type="checkbox"/>	5/24/13 1:00:00 PM	Allow	192.168.2.2	eelsasser	meta.wikimedia.org	Blogs/Wiki	-	2	6 minutes 0 second
<input type="checkbox"/>	5/24/13 1:00:00 PM	Allow	192.168.2.2	eelsasser	feedback.scur.com	Business	-	1	3 minutes 0 second
<input type="checkbox"/>	5/24/13 1:00:00 PM	Allow	192.168.2.2	eelsasser	feedback.scur.com	Business	-	4	3 minutes 0 second
<input type="checkbox"/>	5/24/13 1:00:00 PM	Allow	192.168.2.2	eelsasser	maileast.corp.na.or	Business	-	1	1 minute 8 seconds
<input type="checkbox"/>	5/24/13 1:00:00 PM	Allow	192.168.2.2	eelsasser	api.demandbase.co	Business	-	1	1 second
<input type="checkbox"/>	5/24/13 1:00:00 PM	Allow	192.168.2.2	eelsasser	mscrf.microsoft.com	Business	-	3	1 second
<input type="checkbox"/>	5/24/13 1:00:00 PM	Allow	192.168.2.2	eelsasser	crf.microsoft.com	Business	-	9	3 minutes 0 second
<input type="checkbox"/>	5/24/13 1:00:00 PM	Allow	192.168.2.2	eelsasser	www.microsoft.com	Business	-	1	0 seconds
<input type="checkbox"/>	5/24/13 1:00:00 PM	Allow	192.168.2.2	eelsasser	translate.google.co	Internet Services	Google Translate	2	8 seconds
<input type="checkbox"/>	5/24/13 1:00:00 PM	Allow	192.168.2.2	eelsasser	translate.google.co	Internet Services	Google Translate	3	1 second
<input type="checkbox"/>	5/24/13 1:00:00 PM	Allow	192.168.2.2	eelsasser	www.google.com	Internet Services	-	1	0 seconds
<input type="checkbox"/>	5/24/13 1:00:00 PM	Allow	192.168.2.2	eelsasser	view.atdmt.com	Internet Services	-	1	14 seconds
<input type="checkbox"/>	5/24/13 1:00:00 PM	Allow	192.168.2.2	eelsasser	ssl.gstatic.com	Content Server	-	1	0 seconds
<input type="checkbox"/>	5/24/13 1:00:00 PM	Allow	192.168.2.2	eelsasser	cal.gstatic.com	Content Server	-	8	11 seconds
<input type="checkbox"/>	5/24/13 1:00:00 PM	Allow	192.168.2.2	eelsasser	upload.wikimedia.or	Content Server	-	5	1 second

Actions ▾ 1060 items Back Close

The reporting capabilities must include the ability to schedule aggregate reports of website accesses by categories, ranges of IP addresses and time periods.

# Requirements Response

Queries can group by aggregated fields to produce top-level charts.

The screenshot displays the ePolicy Orchestrator 4.6.5 interface. The browser address bar shows <https://epo.lordchariot.com:3443/console/query/displayQueryCl>. The application title is "ePolicy Orchestrator 4.6.5". The interface includes a menu bar (File, Edit, View, Favorites, Tools, Help) and a navigation pane with options like Dashboards, System Tree, Queries & Reports, Policy Design, Policy Repository, Record Server Settings, and McAfee Web Gateway. The main area is titled "Query Builder" and shows a progress indicator with steps: 1. Result Type, 2. Chart, 3. Columns, and 4. Filter. The current step is "2. Chart", with the question "What type of chart do you want to use to show summary data?".

The "Display Results As" pane on the left lists various chart types under categories: Bar (Bar Chart, Grouped Bar Chart, Stacked Bar Chart), Pie (Boolean Pie Chart, Pie Chart), Bubble (Bubble Chart), Summary (Multi-group Summary Table, Single Group Summary Table), Line (Multi-line Chart, Single Line Chart), and List (Table).

The "Configure Chart: Bar Chart" pane is active, showing a preview of a bar chart with 10 bars of varying heights. To the right of the preview, the "Bar values are:" section has a dropdown menu set to "Sum of" and another dropdown set to "Hits", with a "Show Total" checkbox. The "Horizontal Bars" checkbox is checked. Below the preview, the "Bar labels are:" section has a dropdown menu set to "Category name". A scrollable list of available categories is shown below, including: Bytes from client, Bytes from server, Date and time, Hits, Category Information, Host Information, IP address, Malware Information, Malware name, Request Information, Application name, Application protocol, Content type, File extension, Method, User Information, Username, Action Information, Action taken, Log Source Name Information, Log source name, Log Source Type Information, Log source type, Protection Area Information, Protection area, Reputation Information, Reputation, and Site Information, Site.

At the bottom of the configuration pane, there are buttons for "Back", "Next", "Save", "Run", and "Cancel". The zoom level is set to 100%.

# Requirements Response

Data can also be listed in a table format to display exact details of the data.

The screenshot shows the 'Query Builder' interface with four tabs: '1 Result Type', '2 Chart', '3 Columns', and '4 Filter'. The '3 Columns' tab is active. A text box asks: 'Which columns does the table display? Unless you selected "Table" on the previous panel, this is a drill-down table accessed from the summary chart.' Below this, there are two panels: 'Available Columns' on the left and 'Selected Columns' on the right. The 'Available Columns' panel lists various categories like Bytes, Date and time, HTTP, Category Information, Host Information, Malware Information, Request Information, User Information, Action Information, Log Source Name Information, and Log Source Type Information. The 'Selected Columns' panel shows a list of columns: 'Date and time', 'Action taken', 'IP address', 'Username', 'Site', and 'Category name'. At the bottom right, there are buttons for 'Back', 'Next', 'Save', 'Run', and 'Cancel'.

Exact Detail

Custom: None  Show selected rows

<input type="checkbox"/>	Date and time	Action taken	IP address	Username	Method	Category name	URL	Malware	Application r	Bytes
<input type="checkbox"/>	3/12/13 12:21:19 AM	Allow	192.168.2.2	eelasser	GET	Search Engines	http://www.google.com/	-	-	2.13 MB
<input type="checkbox"/>	3/13/13 12:21:34 AM	Allow	192.168.2.2	global whitelist	GET	Business	http://get.adobe.com/Flashplayer/	-	-	619.24 kB
<input type="checkbox"/>	3/13/13 12:21:51 AM	Allow	192.168.2.2	global whitelist	GET	Business	http://get.adobe.com/Flashplayer/?promoid=JZEFT	-	-	1.37 MB
<input type="checkbox"/>	3/13/13 12:21:51 AM	Allow	192.168.2.2	eelasser	GET	Business	http://www.adobetags.com/d1/adobe/live/getadobeccm.js	-	-	114.49 kB
<input type="checkbox"/>	3/13/13 12:23:36 AM	Allow	192.168.2.2	global whitelist	GET	Business	http://www.images.adobe.com/www.adobe.com/downloadcenter/ja/	-	-	8 kB
<input type="checkbox"/>	3/13/13 12:25:46 AM	Allow	192.168.2.2	eelasser	GET	Search Engines	http://www.google.com/	-	-	5.21 MB
<input type="checkbox"/>	3/13/13 12:25:58 AM	Allow	192.168.2.2	global whitelist	GET	Streaming Media	http://gdata.youtube.com/crossdomain.xml	-	-	17.93 kB
<input type="checkbox"/>	3/13/13 12:26:05 AM	Allow	192.168.2.2	eelasser	GET	Web Ads	http://googleads.g.doubleclick.net/pagead/conversion/?ai=CmDf31F	-	-	2.77 kB
<input type="checkbox"/>	3/13/13 12:26:11 AM	Allow	192.168.2.2	eelasser	GET	Streaming Media	http://www.youtube.com/live_comments?action_get_comments=18	-	YouTube	1.47 kB
<input type="checkbox"/>	3/13/13 12:26:15 AM	Allow	192.168.2.2	eelasser	GET	Web Ads	http://googleads.g.doubleclick.net/pagead/conversion/?ai=CmDf31F	-	-	1.30 kB
<input type="checkbox"/>	3/13/13 12:26:20 AM	Allow	192.168.2.2	eelasser	GET	Internet Services	http://s2.youtube.com/s?plid=AATXaa2BjvRXPQv8adformat=2_2_	-	YouTube	3.93 kB
<input type="checkbox"/>	3/13/13 12:26:30 AM	Allow	192.168.2.2	eelasser	GET	Web Ads	http://googleads.g.doubleclick.net/pagead/conversion/?ai=CmDf31F_UwQjv	-	-	6.02 MB
<input type="checkbox"/>	3/13/13 12:26:41 AM	Allow	192.168.2.2	eelasser	GET	Streaming Media	http://www.youtube.com/live_comments?action_get_comments=18	-	YouTube	3.95 kB
<input type="checkbox"/>	3/13/13 12:26:51 AM	Allow	192.168.2.2	eelasser	GET	Internet Services	http://s2.youtube.com/s?vid=gB_8tjUt0F1F-GH1e7bWgWe8tGGV2N	-	YouTube	1.7 MB
<input type="checkbox"/>	3/13/13 12:27:04 AM	Allow	192.168.2.2	eelasser	GET	Internet Services	http://s2.youtube.com/s?vid=gB_8tjUt0F1F-GH1e7bWgWe8tGGV2N	-	YouTube	3.65 kB
<input type="checkbox"/>	3/13/13 12:27:10 AM	Allow	192.168.2.2	eelasser	GET	Streaming Media	http://r8---sn-jyh3nuab5a-c.youtube.com/videoplayback?alpsnith	-	YouTube	1.7 MB

Actions: 160 items

Reports can be scheduled to run on a periodic basis



# Requirements Response

Server Task Builder

1 Description 2 Actions 3 Schedule 4 Summary

What actions do you want the task to take?

1. Actions: Run Report

Select a report to run: Web Security Overview Summary Language: English

Ignore

Date and time Is within the last 1 Days

Report Runtime Parameters

Sub-Actions: Email File

Recipients: eelsasser@lordchariot.com

Subject: Daily Security Report

The reporting capabilities must include the ability to create "on demand" custom reports on selected client IP addresses, specific URLs and time periods.

## **CDWG Response:**

The same queries and reports that are run on a scheduled basis can be run in an ad-hoc manner with the inclusion runtime selection parameters of any of the available fields

Run

Ignore

Date and time Is within the last 1 Months

URL Contains youtube.com/watch

IP address Is between 192.168.2.0 - 192.168.2.255

Site Contains youtube.com

Username Equals sturdent1

Report Runtime Parameters

OK Cancel



## **CDW Government LLC Response**

Pricing Response

REQUEST FOR QUOTATION  
 EDD392953 Internet Filtering and Reporting Solution

Pricing Page

Exhibit "A"

Item	Vendor Description	Quantity	Unit Cost	Total Cost
Annual software cost for Filtering Servers.* <i>Vendor to specify quantity</i>				
Annual software cost for Reporting Servers.* <i>Vendor to specify quantity</i>	Please reference attached pricing sheet and CDWG Quote # DMPQ253			
Annual License for filtering of client computers on K-12 network.		280,000		
Annual License for mobile computers. (see note 1 below.)		10,000		
Technical support and upgrades/updates for filtering solution		1 year		
One Day onsite training, 6 hours. Charleston WV (see note 2 below)		1 day		
Onsite installation, Charleston and Morgantown, WV (see note 2 below)		4 days		
Filtering Servers (if required)* <i>Vendor is to specify quantity</i>	Please reference attached pricing sheet and CDWG Quote # DMPQ253			
Reporting Servers (if required)* <i>Vendor is to specify quantity</i>	Please reference attached pricing sheet and CDWG Quote # DMPQ253			
Other Hardware (if required)* <i>Vendor is to specify quantity</i>	Please reference attached pricing sheet and CDWG Quote # DMPQ253			
Hourly rate for custom system modifications		20 hours		
<b>Grand Total</b>				\$560,437.10



# SALES QUOTATION

QUOTE NO.	ACCOUNT NO.	DATE
DMPQ253	6280704	6/10/2013

**BILL TO:**  
 WEST VIRGINIA DEPT OF  
 EDUCATION  
 1900 KANAWHA BLVD E  
 BUILDING 7, ROOM 5

**SHIP TO:**  
 WEST VIRGINIA DEPT OF EDUCATION  
 Attention To: CONNIE OSWALD  
 1900 KANAWHA BLVD E  
 BUILDING 7, ROOM 5

Accounts Payable  
 CHARLESTON , WV 25305-0009

CHARLESTON , WV 25305-0009  
 Contact: CONNIE  
 OSWALD 304.558.2157

Customer Phone #304.558.7880

Customer P.O. # RFP WEB FILTERING

ACCOUNT MANAGER		SHIPPING METHOD	TERMS	EXEMPTION CERTIFICATE
MIKE PINTO 866.850.5724		UPS Ground (2- 3 Day)	Net 30 Days-Govt State/Local	GOVT-EXEMPT
QTY	ITEM NO.	DESCRIPTION	UNIT PRICE	EXTENDED PRICE
20	2735622	MCAFEE FED WEB GTW 5500 APPL B 1+ Mfg#: WBG-5500-BI Contract: WV State and Local Government Pricing List Price \$20995.00 Electronic distribution - NO MEDIA	10,224.00	204,480.00
20	2435997	MCAFEE WEB GTW 5500 APPL B-1YR GL+ Mfg#: WBG5500BARMAI Contract: WV State and Local Government Pricing List price \$ 4199.00 1 year support for line 1 Electronic distribution - NO MEDIA	2,556.00	51,120.00
10001	2472283	MCAFEE WEB PROT STE 1:1 10001-20K Mfg#: WPSECE-AA-JI Contract: WV State and Local Government Pricing List price \$9.37 includes a year of support Electronic distribution - NO MEDIA	6.10	61,006.10
4	2186286	MCAFEE GHE SOL SVC SML DPLY CONSULT Mfg#: MD-SMALL-DEPLOYI Contract: WV State and Local Government Pricing List price \$17,000 Electronic distribution - NO MEDIA	16,000.00	64,000.00
190000	2383156	MCAFEE WEB SEC P:1 50001+ Mfg#: WSGCKE-AA-LI Contract: WV State and Local Government Pricing List price \$ 7.56 includes a year of support Electronic distribution - NO MEDIA	0.85	161,500.00
1	2769153	HP SB PROLIANT DL385P GEN8 6234 Mfg#: 686852-S01 Contract: WV State and Local Government Pricing	2,825.00	2,825.00
6	2806500	HP SB 8GB 2RX4 PC3L-10600R-9 KIT Mfg#: 647877-S21 Contract: WV State and Local Government Pricing	88.00	528.00
6	2775192	HP 900GB 6G SAS 10K 2.5 GEN8 Mfg#: 652589-S21 Contract: WV State and Local Government Pricing	623.00	3,738.00
1	1706188	CDW HARDWARE INSTALL SERVER Mfg#: HWINSTALLSERVER Contract: WV State and Local Government Pricing	30.00	30.00
1	076980	CDW NETWORK OPERATING SYSTEM INSTALL Mfg#: INSTALLNETOS Contract: WV State and Local Government Pricing	230.00	230.00
1	931000	CDW NETWORK APPLICATION INSTALL Mfg#: INSTALLNETSOFTWAR Contract: WV State and Local Government Pricing	120.00	120.00
2	2803261	ACAD MS MBA WIN SRV STD 2012 2PROC Mfg#: P73-05828 Contract: WV State and Local Government Pricing Electronic distribution - NO MEDIA	210.00	420.00

12	2668369	ACAD MS MBA SQL SRV STD CORE 2LIC Mfg#: 7NQ-00256 Contract: WV State and Local Government Pricing Electronic distribution - NO MEDIA	870.00	10,440.00
				560,437.10
				0.00
				0.00
				US Currency
				<b>TOTAL</b> ▶ <b>560,437.10</b>

CDW Government  
230 North Milwaukee Ave.  
Vernon Hills, IL 60061

Fax: 847.990.8190

**Please remit payment to:**  
CDW Government  
75 Remittance Drive  
Suite 1515  
Chicago, IL 60675-1515

Item	Vendor Description	Quantity	Unit Cost	Total Cost
Annual software cost for filtering servers.* Vendor to Sepcify Quantity	WBG5500BARMAI - MFE Web Gateway 5500 Appl-B 1Yr GL+ARMA	20	\$ 2,556.00	\$ 51,120.00
Annual software cost for reporting servers.* Vendor to Sepcify Quantity	N/A			\$ -
Annual License for filtering of client computers on K-12 network	WSGCKE-AA-LI - MFE Web Security P:1 GL *Number of Licenses needed for this deployment type and architecture has been adjusted to 190000 by McAfee Senior Management.	190000	\$ 0.85	\$ 161,500.00
Annual License for mobile computers	WPSECE-AA - MFE Web Protection Suite 1:1 GL	10000	\$ 6.10	\$ 61,000.00 **
Technical Support and Upgrades/Updates for filtering solution	Included in annual software cost for filtering servers, annual license cost for filtering of client computers on K-12 network & annual license cost for mobile computers	1 Year	Included in Line 3	
One day onsite training, 6hours Charleston WV	List as \$0 and move this cost into the license and hardware.	1 Day	Included	
Onsite installation, Charleston and Morgantown, WV	List as \$0 and move this cost into the license and hardware.	4 Days	Included	
Filtering Servers (if required)* Vendor is to specify Qty	Cost of SQL license and any hardware from CDW.		4,996.00	\$18,331.00
Reporting Servers	Cost of SQL license and any hardware from CDW.			\$ -
Other Hardware	N/A			\$ -
Hourly rate for custom system modifications	List as \$0 and move this cost into the license and hardware.	20 hours		
Grand Total				\$ 291,951.00

\*The total of quoted solutions is \$560,437.10. Please reference attached CDWG Quote # DMPQ253 for complete item listing.

## State of West Virginia VENDOR PREFERENCE CERTIFICATE

Certification and application\* is hereby made for Preference in accordance with *West Virginia Code*, §5A-3-37. (Does not apply to construction contracts). *West Virginia Code*, §5A-3-37, provides an opportunity for qualifying vendors to request (at the time of bid) preference for their residency status. Such preference is an evaluation method only and will be applied only to the cost bid in accordance with the *West Virginia Code*. This certificate for application is to be used to request such preference. The Purchasing Division will make the determination of the Resident Vendor Preference, if applicable.

1. **Application is made for 2.5% resident vendor preference for the reason checked:**  
 Bidder is an individual resident vendor and has resided continuously in West Virginia for four (4) years immediately preceding the date of this certification; or,  
 Bidder is a partnership, association or corporation resident vendor and has maintained its headquarters or principal place of business continuously in West Virginia for four (4) years immediately preceding the date of this certification; or 80% of the ownership interest of Bidder is held by another individual, partnership, association or corporation resident vendor who has maintained its headquarters or principal place of business continuously in West Virginia for four (4) years immediately preceding the date of this certification; or,  
 Bidder is a nonresident vendor which has an affiliate or subsidiary which employs a minimum of one hundred state residents and which has maintained its headquarters or principal place of business within West Virginia continuously for the four (4) years immediately preceding the date of this certification; or,
2. **Application is made for 2.5% resident vendor preference for the reason checked:**  
 Bidder is a resident vendor who certifies that, during the life of the contract, on average at least 75% of the employees working on the project being bid are residents of West Virginia who have resided in the state continuously for the two years immediately preceding submission of this bid; or,
3. **Application is made for 2.5% resident vendor preference for the reason checked:**  
 Bidder is a nonresident vendor employing a minimum of one hundred state residents or is a nonresident vendor with an affiliate or subsidiary which maintains its headquarters or principal place of business within West Virginia employing a minimum of one hundred state residents who certifies that, during the life of the contract, on average at least 75% of the employees or Bidder's affiliate's or subsidiary's employees are residents of West Virginia who have resided in the state continuously for the two years immediately preceding submission of this bid; or,
4. **Application is made for 5% resident vendor preference for the reason checked:**  
 Bidder meets either the requirement of both subdivisions (1) and (2) or subdivision (1) and (3) as stated above; or,
5. **Application is made for 3.5% resident vendor preference who is a veteran for the reason checked:**  
 Bidder is an individual resident vendor who is a veteran of the United States armed forces, the reserves or the National Guard and has resided in West Virginia continuously for the four years immediately preceding the date on which the bid is submitted; or,
6. **Application is made for 3.5% resident vendor preference who is a veteran for the reason checked:**  
 Bidder is a resident vendor who is a veteran of the United States armed forces, the reserves or the National Guard, if, for purposes of producing or distributing the commodities or completing the project which is the subject of the vendor's bid and continuously over the entire term of the project, on average at least seventy-five percent of the vendor's employees are residents of West Virginia who have resided in the state continuously for the two immediately preceding years.
7. **Application is made for preference as a non-resident small, women- and minority-owned business, in accordance with *West Virginia Code* §5A-3-59 and *West Virginia Code of State Rules*.**  
 Bidder has been or expects to be approved prior to contract award by the Purchasing Division as a certified small, women- and minority-owned business.

Bidder understands if the Secretary of Revenue determines that a Bidder receiving preference has failed to continue to meet the requirements for such preference, the Secretary may order the Director of Purchasing to: (a) reject the bid, or (b) assess a penalty against such Bidder in an amount not to exceed 5% of the bid amount and that such penalty will be paid to the contracting agency or deducted from any unpaid balance on the contract or purchase order.

By submission of this certificate, Bidder agrees to disclose any reasonably requested information to the Purchasing Division and authorizes the Department of Revenue to disclose to the Director of Purchasing appropriate information verifying that Bidder has paid the required business taxes, provided that such information does not contain the amounts of taxes paid nor any other information deemed by the Tax Commissioner to be confidential.

Under penalty of law for false swearing (*West Virginia Code*, §61-5-3), Bidder hereby certifies that this certificate is true and accurate in all respects; and that if a contract is issued to Bidder and if anything contained within this certificate changes during the term of the contract, Bidder will notify the Purchasing Division in writing immediately.

Bidder: \_\_\_\_\_ Signed: \_\_\_\_\_  
 Date: \_\_\_\_\_ Title: \_\_\_\_\_

RFQ No. EDD392953

STATE OF WEST VIRGINIA  
Purchasing Division

**PURCHASING AFFIDAVIT**

**MANDATE:** Under W. Va. Code §5A-3-10a, no contract or renewal of any contract may be awarded by the state or any of its political subdivisions to any vendor or prospective vendor when the vendor or prospective vendor or a related party to the vendor or prospective vendor is a debtor and (1) the debt owed is an amount greater than one thousand dollars in the aggregate; or (2) the debtor is in employer default.

**EXCEPTION:** The prohibition listed above does not apply where a vendor has contested any tax administered pursuant to chapter eleven of the W. Va. Code, workers' compensation premium, permit fee or environmental fee or assessment and the matter has not become final or where the vendor has entered into a payment plan or agreement and the vendor is not in default of any of the provisions of such plan or agreement.

**DEFINITIONS:**

"Debt" means any assessment, premium, penalty, fine, tax or other amount of money owed to the state or any of its political subdivisions because of a judgment, fine, permit violation, license assessment, defaulted workers' compensation premium, penalty or other assessment presently delinquent or due and required to be paid to the state or any of its political subdivisions, including any interest or additional penalties accrued thereon.

"Employer default" means having an outstanding balance or liability to the old fund or to the uninsured employers' fund or being in policy default, as defined in W. Va. Code § 23-2c-2, failure to maintain mandatory workers' compensation coverage, or failure to fully meet its obligations as a workers' compensation self-insured employer. An employer is not in employer default if it has entered into a repayment agreement with the Insurance Commissioner and remains in compliance with the obligations under the repayment agreement.

"Related party" means a party, whether an individual, corporation, partnership, association, limited liability company or any other form or business association or other entity whatsoever, related to any vendor by blood, marriage, ownership or contract through which the party has a relationship of ownership or other interest with the vendor so that the party will actually or by effect receive or control a portion of the benefit, profit or other consideration from performance of a vendor contract with the party receiving an amount that meets or exceeds five percent of the total contract amount.

**AFFIRMATION:** By signing this form, the vendor's authorized signer affirms and acknowledges under penalty of law for false swearing (W. Va. Code §61-5-3) that neither vendor nor any related party owe a debt as defined above and that neither vendor nor any related party are in employer default as defined above, unless the debt or employer default is permitted under the exception above.

**WITNESS THE FOLLOWING SIGNATURE:**

Vendor's Name: CDW Government LLC

Authorized Signature: [Signature] Date: 6/12/2013

State of Illinois

County of Cook, to-wit:

Taken, subscribed, and sworn to before me this 10<sup>th</sup> day of June, 2013

My Commission expires 5/18, 2013.

AFFIX SEAL HERE

NOTARY PUBLIC [Signature]  
*Purchasing Affidavit (Revised 07/01/2012)*





CERTIFICATION AND SIGNATURE PAGE

By signing below, I certify that I have reviewed this Solicitation in its entirety; understand the requirements, terms and conditions, and other information contained herein; that I am submitting this bid or proposal for review and consideration; that I am authorized by the bidder to execute this bid or any documents related thereto on bidder's behalf; that I am authorized to bind the bidder in a contractual relationship; and that to the best of my knowledge, the bidder has properly registered with any State agency that may require registration.

CDW Government LLC

(Company)

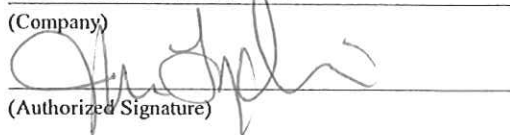

(Authorized Signature)

John Loughlin – Supervisor, Proposals

(Representative Name, Title)

866.850.5724

(Phone Number)

847-990-8190

(Fax Number)

6/12/2013

(Date)

**ADDENDUM ACKNOWLEDGEMENT FORM**  
**SOLICITATION NO.:** EDD392953

**Instructions:** Please acknowledge receipt of all addenda issued with this solicitation by completing this addendum acknowledgment form. Check the box next to each addendum received and sign below. Failure to acknowledge addenda may result in bid disqualification.

**Acknowledgment:** I hereby acknowledge receipt of the following addenda and have made the necessary revisions to my proposal, plans and/or specification, etc.

**Addendum Numbers Received:**

(Check the box next to each addendum received)

- |  |  |
|--|--|
| <input checked="" type="checkbox"/> Addendum No. 1 | <input type="checkbox"/> Addendum No. 6  |
| <input type="checkbox"/> Addendum No. 2            | <input type="checkbox"/> Addendum No. 7  |
| <input type="checkbox"/> Addendum No. 3            | <input type="checkbox"/> Addendum No. 8  |
| <input type="checkbox"/> Addendum No. 4            | <input type="checkbox"/> Addendum No. 9  |
| <input type="checkbox"/> Addendum No. 5            | <input type="checkbox"/> Addendum No. 10 |

I understand that failure to confirm the receipt of addenda may be cause for rejection of this bid. I further understand that any verbal representation made or assumed to be made during any oral discussion held between Vendor's representatives and any state personnel is not binding. Only the information issued in writing and added to the specifications by an official addendum is binding.

CDW Government LLC

Company

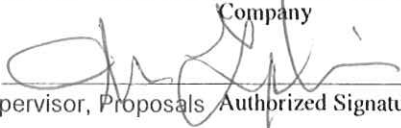
  
 John Loughlin – Supervisor, Proposals Authorized Signature

6/12/2013

Date

**NOTE:** This addendum acknowledgement should be submitted with the bid to expedite document processing.

**ADDENDUM ACKNOWLEDGEMENT FORM**  
**SOLICITATION NO.: EDD392953**

**Instructions:** Please acknowledge receipt of all addenda issued with this solicitation by completing this addendum acknowledgment form. Check the box next to each addendum received and sign below. Failure to acknowledge addenda may result in bid disqualification.

**Acknowledgment:** I hereby acknowledge receipt of the following addenda and have made the necessary revisions to my proposal, plans and/or specification, etc.

**Addendum Numbers Received:**

(Check the box next to each addendum received)

- |  |  |
|--|--|
| <input checked="" type="checkbox"/> Addendum No. 1 | <input type="checkbox"/> Addendum No. 6  |
| <input type="checkbox"/> Addendum No. 2            | <input type="checkbox"/> Addendum No. 7  |
| <input type="checkbox"/> Addendum No. 3            | <input type="checkbox"/> Addendum No. 8  |
| <input type="checkbox"/> Addendum No. 4            | <input type="checkbox"/> Addendum No. 9  |
| <input type="checkbox"/> Addendum No. 5            | <input type="checkbox"/> Addendum No. 10 |

I understand that failure to confirm the receipt of addenda may be cause for rejection of this bid. I further understand that any verbal representation made or assumed to be made during any oral discussion held between Vendor's representatives and any state personnel is not binding. Only the information issued in writing and added to the specifications by an official addendum is binding.

CDW Government LLC

Company

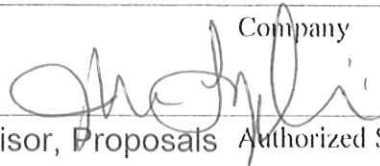

John Loughlin – Supervisor, Proposals Authorized Signature

6/12/2013

Date

NOTE: This addendum acknowledgment should be submitted with the bid to expedite document processing.  
Revised 6/8/2012