



State of West Virginia
 Department of Administration
 Purchasing Division
 2019 Washington Street East
 Post Office Box 50130
 Charleston, WV 25305-0130

Solicitation

NUMBER
 DEFK13022

PAGE
 1

ADDRESS CORRESPONDENCE TO ATTENTION OF:
 TARA LYLE
 304-558-2544

RFQ COPY
 TYPE NAME/ADDRESS HERE
 VENDOR

 677 MERRITTS CREEK ROAD
 HUNTINGTON, WV 25702

SHIP TO
 DIV ENGINEERING & FACILITIES
 ARMORY BOARD SECTION
 1707 COONSKIN DRIVE
 CHARLESTON, WV
 25311-1099 304-341-6368

DATE PRINTED
 06/06/2013

BID OPENING DATE: 06/25/2013 BID OPENING TIME 1:30PM

| LINE | QUANTITY | UOP | CAT. NO. | ITEM NUMBER | UNIT PRICE | AMOUNT |
|--|----------|-----|----------|------------------------|------------|-----------|
| THE WEST VIRGINIA PURCHASING DIVISION FOR THE AGENCY, WV DIVISION OF ENGINEERING AND FACILITIES, IS SOLICITING BIDS TO PROVIDE (5) FIVE SUB-COMPACT DIESEL TRACTORS WITH (5) FIVE MID-MOUNT MOWER AND (5) FIVE SNOW DOZER BLADE, OR EQUAL PER THE ATTACHED SPECIFICATIONS. ATTACHMENTS INCLUDE: 1. INSTRUCTIONS TO VENDORS SUBMITTING BIDS 2. GENERAL TERMS AND CONDITIONS 3. DEFK13022 SPECIFICATIONS 4. CERTIFICATION AND SIGNATURE PAGE 5. PURCHASING AFFIDAVIT 6. RESIDENT VENDOR PREFERENCE (RVP) FORM | | | | | | |
| 0001 | 5 | EA | 765-87 | John DEKNE 1025R | 9616.17 | 48,080.85 |
| 0002 | 5 | EA | 020-68 | 690 DECK John DEKNE | 1904.80 | 9524.00 |

06/25/13 01:23:40 PM
 West Virginia Purchasing Division

SIGNATURE *Dee Muelh* TELEPHONE (304) 736 2120 DATE 6/24/13
 TITLE *Manning* FEIN 34-1800484 ADDRESS CHANGES TO BE NOTED ABOVE

WHEN RESPONDING TO SOLICITATION, INSERT NAME AND ADDRESS IN SPACE ABOVE LABELED 'VENDOR'



State of West Virginia
 Department of Administration
 Purchasing Division
 2019 Washington Street East
 Post Office Box 50130
 Charleston, WV 25305-0130

Solicitation

NUMBER
 DEFK13022

PAGE
 2

ADDRESS CORRESPONDENCE TO ATTENTION OF:
 TARA LYLE
 304-558-2544

RFQ COPY
 TYPE NAME/ADDRESS HERE
 VENDOR

BRIDGEPORT
 EQUIPMENT & SUPPLY
 677 MERRITTS CREEK ROAD
 HUNTINGTON, WV 25702

SHIP TO
 DIV ENGINEERING & FACILITIES
 ARMORY BOARD SECTION
 1707 COONSKIN DRIVE
 CHARLESTON, WV
 25311-1099 304-341-6368

DATE PRINTED
 06/06/2013

BID OPENING DATE: 06/25/2013 BID OPENING TIME 1:30PM

| LINE | QUANTITY | UOP | CAT. NO. | ITEM NUMBER | UNIT PRICE | AMOUNT |
|---|----------|-----|----------|-------------------------------------|------------|----------|
| 0003 | 5 | EA | | 968-72 John Deere 54 QT BLADE | 1248.72 | 6243.60 |
| ***** THIS IS THE END OF RFQ DEFK13022 ***** TOTAL: | | | | | | 63848.45 |

SIGNATURE *Dan Mills* TELEPHONE (304) 736 2120 DATE 6/24/13
 TITLE MANAGER FEIN 34-1800484 ADDRESS CHANGES TO BE NOTED ABOVE

WHEN RESPONDING TO SOLICITATION, INSERT NAME AND ADDRESS IN SPACE ABOVE LABELED 'VENDOR'

INSTRUCTIONS TO VENDORS SUBMITTING BIDS

1. **REVIEW DOCUMENTS THOROUGHLY:** The attached documents contain a solicitation for bids. Please read these instructions and all documents attached in their entirety. These instructions provide critical information about requirements that if overlooked could lead to disqualification of a Vendor's bid. All bids must be submitted in accordance with the provisions contained in these instructions and the Solicitation. Failure to do so may result in disqualification of Vendor's bid.
2. **MANDATORY TERMS:** The Solicitation may contain mandatory provisions identified by the use of the words "must," "will," and "shall." Failure to comply with a mandatory term in the Solicitation will result in bid disqualification.
3. **PREBID MEETING:** The item identified below shall apply to this Solicitation.

A pre-bid meeting will not be held prior to bid opening.

A NON-MANDATORY PRE-BID meeting will be held at the following place and time:

| |
|--|
| |
|--|

A MANDATORY PRE-BID meeting will be held at the following place and time:

| |
|--|
| |
|--|

All Vendors submitting a bid must attend the mandatory pre-bid meeting. Failure to attend the mandatory pre-bid meeting shall result in disqualification of the Vendor's bid. No one person attending the pre-bid meeting may represent more than one Vendor.

An attendance sheet provided at the pre-bid meeting shall serve as the official document verifying attendance. The State will not accept any other form of proof or documentation to verify attendance. Any person attending the pre-bid meeting on behalf of a Vendor must list on the attendance sheet his or her name and the name of the Vendor he or she is representing. Additionally, the person attending the pre-bid meeting should include the Vendor's E-Mail address, phone number, and Fax number on the attendance sheet. It is the Vendor's responsibility to locate the attendance sheet and provide the required

information. Failure to complete the attendance sheet as required may result in disqualification of Vendor's bid.

All Vendors should arrive prior to the starting time for the pre-bid. Vendors who arrive after the starting time but prior to the end of the pre-bid will be permitted to sign in, but are charged with knowing all matters discussed at the pre-bid.

Questions submitted at least five business days prior to a scheduled pre-bid will be discussed at the pre-bid meeting if possible. Any discussions or answers to questions at the pre-bid meeting are preliminary in nature and are non-binding. Official and binding answers to questions will be published in a written addendum to the Solicitation prior to bid opening.

4. **VENDOR QUESTION DEADLINE:** Vendors may submit questions relating to this Solicitation to the Purchasing Division. Questions must be submitted in writing. All questions must be submitted on or before the date listed below and to the address listed below in order to be considered. A written response will be published in a Solicitation addendum if a response is possible and appropriate. Non-written discussions, conversations, or questions and answers regarding this Solicitation are preliminary in nature and are non-binding.

Question Submission Deadline: June 17, 2013 at 2:00 pm

Submit Questions to:

Tara Lyle, File 32

2019 Washington Street, East

P.O. Box 50130

Charleston, WV 25305

Fax: 304-558-4115

Email: Tara.L.Lyle@wv.gov

5. **VERBAL COMMUNICATION:** Any verbal communication between the Vendor and any State personnel is not binding, including that made at the mandatory pre-bid conference. Only information issued in writing and added to the Solicitation by an official written addendum by the Purchasing Division is binding.
6. **BID SUBMISSION:** All bids must be signed and delivered by the Vendor to the Purchasing Division at the address listed below on or before the date and time of the bid opening. Any bid received by the Purchasing Division staff is considered to be in the possession of the Purchasing Division and will not be returned for any reason. The bid delivery address is:

Department of Administration, Purchasing Division
 2019 Washington Street East
 P.O. Box 50130,
 Charleston, WV 25305-0130

The bid should contain the information listed below on the face of the envelope or the bid may not be considered:

SEALED BID

BUYER: _____
 SOLICITATION NO.: _____
 BID OPENING DATE: _____
 BID OPENING TIME: _____
 FAX NUMBER: _____

In the event that Vendor is responding to a request for proposal, the Vendor shall submit one original technical and one original cost proposal plus n/a convenience copies of each to the Purchasing Division at the address shown above. Additionally, the Vendor should identify the bid type as either a technical or cost proposal on the face of each bid envelope submitted in response to a request for proposal as follows:

BID TYPE: Technical
 Cost

7. **BID OPENING:** Bids submitted in response to this Solicitation will be opened at the location identified below on the date and time listed below. Delivery of a bid after the bid opening date and time will result in bid disqualification. For purposes of this Solicitation, a bid is considered delivered when time stamped by the official Purchasing Division time clock.

Bid Opening Date and Time:

June 25, 2013 at 1:30 pm

Bid Opening Location:

Department of Administration, Purchasing Division
 2019 Washington Street East
 P.O. Box 50130,
 Charleston, WV 25305-0130

8. **ADDENDUM ACKNOWLEDGEMENT:** Changes or revisions to this Solicitation will be made by an official written addendum issued by the Purchasing Division. Vendor should acknowledge receipt of all addenda issued with this Solicitation by completing an Addendum Acknowledgment Form, a copy of which is included herewith. Failure to acknowledge addenda may result in bid disqualification. The addendum acknowledgement should be submitted with the bid to expedite document processing.
9. **BID FORMATTING:** Vendor should type or electronically enter the information onto its bid to prevent errors in the evaluation. Failure to type or electronically enter the information may result in bid disqualification.

GENERAL TERMS AND CONDITIONS:

1. **CONTRACTUAL AGREEMENT:** Issuance of a Purchase Order signed by the Purchasing Division Director, or his designee, and approved as to form by the Attorney General's office constitutes acceptance of this Contract made by and between the State of West Virginia and the Vendor. Vendor's signature on its bid signifies Vendor's agreement to be bound by and accept the terms and conditions contained in this Contract.

2. **DEFINITIONS:** As used in this Solicitation / Contract, the following terms shall have the meanings attributed to them below. Additional definitions may be found in the specifications included with this Solicitation / Contract.
 - 2.1 "Agency" or "Agencies" means the agency, board, commission, or other entity of the State of West Virginia that is identified on the first page of the Solicitation or any other public entity seeking to procure goods or services under this Contract.
 - 2.2 "Contract" means the binding agreement that is entered into between the State and the Vendor to provide the goods and services requested in the Solicitation.
 - 2.3 "Director" means the Director of the West Virginia Department of Administration, Purchasing Division.
 - 2.4 "Purchasing Division" means the West Virginia Department of Administration, Purchasing Division.
 - 2.5 "Purchase Order" means the document signed by the Agency and the Purchasing Division, and approved as to form by the Attorney General, that identifies the Vendor as the successful bidder and Contract holder.
 - 2.6 "Solicitation" means the official solicitation published by the Purchasing Division and identified by number on the first page thereof.
 - 2.7 "State" means the State of West Virginia and/or any of its agencies, commissions, boards, etc. as context requires.
 - 2.8 "Vendor" or "Vendors" means any entity submitting a bid in response to the Solicitation, the entity that has been selected as the lowest responsible bidder, or the entity that has been awarded the Contract as context requires.

3. **CONTRACT TERM; RENEWAL; EXTENSION:** The term of this Contract shall be determined in accordance with the category that has been identified as applicable to this Contract below:

Term Contract

Initial Contract Term: This Contract becomes effective on

 and extends for a period of year(s).

Renewal Term: This Contract may be renewed upon the mutual written consent of the Agency, and the Vendor, with approval of the Purchasing Division and the Attorney General's office (Attorney General approval is as to form only). Any request for renewal must be submitted to the Purchasing Division Director thirty (30) days prior to the expiration date of the initial contract term or appropriate renewal term. A Contract renewal shall be in accordance with the terms and conditions of the original contract. Renewal of this Contract is limited to successive one (1) year periods. Automatic renewal of this Contract is prohibited. Notwithstanding the foregoing, Purchasing Division approval is not required on agency delegated or exempt purchases. Attorney General approval may be required for vendor terms and conditions.

Reasonable Time Extension: At the sole discretion of the Purchasing Division Director, and with approval from the Attorney General's office (Attorney General approval is as to form only), this Contract may be extended for a reasonable time after the initial Contract term or after any renewal term as may be necessary to obtain a new contract or renew this Contract. Any reasonable time extension shall not exceed twelve (12) months. Vendor may avoid a reasonable time extension by providing the Purchasing Division Director with written notice of Vendor's desire to terminate this Contract 30 days prior to the expiration of the then current term. During any reasonable time extension period, the Vendor may terminate this Contract for any reason upon giving the Purchasing Division Director 30 days written notice. Automatic extension of this Contract is prohibited. Notwithstanding the foregoing, Purchasing Division approval is not required on agency delegated or exempt purchases, but Attorney General approval may be required.

- Fixed Period Contract:** This Contract becomes effective upon Vendor's receipt of the notice to proceed and must be completed within days.
- One Time Purchase:** The term of this Contract shall run from the issuance of the Purchase Order until all of the goods contracted for have been delivered, but in no event shall this Contract extend for more than one fiscal year.
- Other:** See attached.

4. **NOTICE TO PROCEED:** Vendor shall begin performance of this Contract immediately upon receiving notice to proceed unless otherwise instructed by the Agency. Unless otherwise specified, the fully executed Purchase Order will be considered notice to proceed
5. **QUANTITIES:** The quantities required under this Contract shall be determined in accordance with the category that has been identified as applicable to this Contract below.
- Open End Contract:** Quantities listed in this Solicitation are approximations only, based on estimates supplied by the Agency. It is understood and agreed that the Contract shall cover the quantities actually ordered for delivery during the term of the Contract, whether more or less than the quantities shown.
- Service:** The scope of the service to be provided will be more clearly defined in the specifications included herewith.
- Combined Service and Goods:** The scope of the service and deliverable goods to be provided will be more clearly defined in the specifications included herewith.
- One Time Purchase:** This Contract is for the purchase of a set quantity of goods that are identified in the specifications included herewith. Once those items have been delivered, no additional goods may be procured under this Contract without an appropriate change order approved by the Vendor, Agency, Purchasing Division, and Attorney General's office.
6. **PRICING:** The pricing set forth herein is firm for the life of the Contract, unless specified elsewhere within this Solicitation/Contract by the State. A Vendor's inclusion of price adjustment provisions in its bid, without an express authorization from the State in the Solicitation to do so, may result in bid disqualification.
7. **EMERGENCY PURCHASES:** The Purchasing Division Director may authorize the Agency to purchase goods or services in the open market that Vendor would otherwise provide under this Contract if those goods or services are for immediate or expedited delivery in an emergency. Emergencies shall include, but are not limited to, delays in transportation or an unanticipated increase in the volume of work. An emergency purchase in the open market, approved by the Purchasing Division Director, shall not constitute of breach of this Contract and shall not entitle the Vendor to any form of compensation or damages. This provision does not excuse the State from fulfilling its obligations under a One Time Purchase contract.
8. **REQUIRED DOCUMENTS:** All of the items checked below must be provided to the Purchasing Division by the Vendor as specified below.
- BID BOND:** All Vendors shall furnish a bid bond in the amount of five percent (5%) of the total amount of the bid protecting the State of West Virginia. The bid bond must be submitted with the bid.

PERFORMANCE BOND: The apparent successful Vendor shall provide a performance bond in the amount of . The performance bond must be issued and received by the Purchasing Division prior to Contract award. On construction contracts, the performance bond must be 100% of the Contract value.

LABOR/MATERIAL PAYMENT BOND: The apparent successful Vendor shall provide a labor/material payment bond in the amount of 100% of the Contract value. The labor/material payment bond must be issued and delivered to the Purchasing Division prior to Contract award.

In lieu of the Bid Bond, Performance Bond, and Labor/Material Payment Bond, the Vendor may provide certified checks, cashier's checks, or irrevocable letters of credit. Any certified check, cashier's check, or irrevocable letter of credit provided in lieu of a bond must be of the same amount and delivered on the same schedule as the bond it replaces. A letter of credit submitted in lieu of a performance and labor/material payment bond will only be allowed for projects under \$100,000. Personal or business checks are not acceptable.

MAINTENANCE BOND: The apparent successful Vendor shall provide a two (2) year maintenance bond covering the roofing system. The maintenance bond must be issued and delivered to the Purchasing Division prior to Contract award.

WORKERS' COMPENSATION INSURANCE: The apparent successful Vendor shall have appropriate workers' compensation insurance and shall provide proof thereof upon request.

INSURANCE: The apparent successful Vendor shall furnish proof of the following insurance prior to Contract award:

Commercial General Liability Insurance:
 or more.

Builders Risk Insurance: builders risk – all risk insurance in an amount equal to 100% of the amount of the Contract.

The apparent successful Vendor shall also furnish proof of any additional insurance requirements contained in the specifications prior to Contract award regardless of whether or not that insurance requirement is listed above.

- LICENSE(S) / CERTIFICATIONS / PERMITS:** In addition to anything required under the Section entitled Licensing, of the General Terms and Conditions, the apparent successful Vendor shall furnish proof of the following licenses, certifications, and/or permits prior to Contract award, in a form acceptable to the Purchasing Division.

The apparent successful Vendor shall also furnish proof of any additional licenses or certifications contained in the specifications prior to Contract award regardless of whether or not that requirement is listed above.

9. **LITIGATION BOND:** The Director reserves the right to require any Vendor that files a protest of an award to submit a litigation bond in the amount equal to one percent of the lowest bid submitted or \$5,000, whichever is greater. The entire amount of the bond shall be forfeited if the hearing officer determines that the protest was filed for frivolous or improper purpose, including but not limited to, the purpose of harassing, causing unnecessary delay, or needless expense for the Agency. All litigation bonds shall be made payable to the Purchasing Division. In lieu of a bond, the protester may submit a cashier's check or certified check payable to the Purchasing Division. Cashier's or certified checks will be deposited with and held by the State Treasurer's office. If it is determined that the protest has not been filed for frivolous or improper purpose, the bond or deposit shall be returned in its entirety.
10. **ALTERNATES:** Any model, brand, or specification listed herein establishes the acceptable level of quality only and is not intended to reflect a preference for, or in any way favor, a particular brand or vendor. Vendors may bid alternates to a listed model or brand provided that the alternate is at least equal to the model or brand and complies with the required specifications. The equality of any alternate being bid shall be determined by the State at its sole discretion. Any Vendor bidding an alternate model or brand should clearly identify the alternate items in its bid and should include manufacturer's specifications, industry literature, and/or any other relevant documentation demonstrating the equality of the alternate items. Failure to provide information for alternate items may be grounds for rejection of a Vendor's bid.
11. **EXCEPTIONS AND CLARIFICATIONS:** The Solicitation contains the specifications that shall form the basis of a contractual agreement. Vendor shall clearly mark any exceptions, clarifications, or

other proposed modifications in its bid. Exceptions to, clarifications of, or modifications of a requirement or term and condition of the Solicitation may result in bid disqualification.

12. LIQUIDATED DAMAGES: Vendor shall pay liquidated damages in the amount

| | | |
|--|-----|--|
| | for | |
| | | |

This clause shall in no way be considered exclusive and shall not limit the State or Agency's right to pursue any other available remedy.

- 13. ACCEPTANCE/REJECTION:** The State may accept or reject any bid in whole, or in part. Vendor's signature on its bid signifies acceptance of the terms and conditions contained in the Solicitation and Vendor agrees to be bound by the terms of the Contract, as reflected in the Purchase Order, upon receipt.
- 14. REGISTRATION:** Prior to Contract award, the apparent successful Vendor must be properly registered with the West Virginia Purchasing Division and must have paid the \$125 fee if applicable.
- 15. COMMUNICATION LIMITATIONS:** In accordance with West Virginia Code of State Rules §148-1-6.6, communication with the State of West Virginia or any of its employees regarding this Solicitation during the solicitation, bid, evaluation or award periods, except through the Purchasing Division, is strictly prohibited without prior Purchasing Division approval. Purchasing Division approval for such communication is implied for all agency delegated and exempt purchases.
- 16. FUNDING:** This Contract shall continue for the term stated herein, contingent upon funds being appropriated by the Legislature or otherwise being made available. In the event funds are not appropriated or otherwise made available, this Contract becomes void and of no effect beginning on July 1 of the fiscal year for which funding has not been appropriated or otherwise made available.
- 17. PAYMENT:** Payment in advance is prohibited under this Contract. Payment may only be made after the delivery and acceptance of goods or services. The Vendor shall submit invoices, in arrears, to the Agency at the address on the face of the purchase order labeled "Invoice To."
- 18. UNIT PRICE:** Unit prices shall prevail in cases of a discrepancy in the Vendor's bid.
- 19. DELIVERY:** All quotations are considered freight on board destination ("F.O.B. destination") unless alternate shipping terms are clearly identified in the bid. Vendor's listing of shipping terms that contradict the shipping terms expressly required by this Solicitation may result in bid disqualification.
- 20. INTEREST:** Interest attributable to late payment will only be permitted if authorized by the West Virginia Code. Presently, there is no provision in the law for interest on late payments.
- 21. PREFERENCE:** Vendor Preference may only be granted upon written request and only in accordance with the West Virginia Code § 5A-3-37 and the West Virginia Code of State Rules. A Resident Vendor Certification form has been attached hereto to allow Vendor to apply for the preference. Vendor's

failure to submit the Resident Vendor Certification form with its bid will result in denial of Vendor Preference. Vendor Preference does not apply to construction projects.

22. **SMALL, WOMEN-OWNED, OR MINORITY-OWNED BUSINESSES:** For any solicitations publicly advertised for bid on or after July 1, 2012, in accordance with West Virginia Code §5A-3-37(a)(7) and W. Va. CSR § 148-22-9, any non-resident vendor certified as a small, women-owned, or minority-owned business under W. Va. CSR § 148-22-9 shall be provided the same preference made available to any resident vendor. Any non-resident small, women-owned, or minority-owned business must identify itself as such in writing, must submit that writing to the Purchasing Division with its bid, and must be properly certified under W. Va. CSR § 148-22-9 prior to submission of its bid to receive the preferences made available to resident vendors. Preference for a non-resident small, women-owned, or minority owned business shall be applied in accordance with W. Va. CSR § 148-22-9.
23. **TAXES:** The Vendor shall pay any applicable sales, use, personal property or any other taxes arising out of this Contract and the transactions contemplated thereby. The State of West Virginia is exempt from federal and state taxes and will not pay or reimburse such taxes.
24. **CANCELLATION:** The Purchasing Division Director reserves the right to cancel this Contract immediately upon written notice to the vendor if the materials or workmanship supplied do not conform to the specifications contained in the Contract. The Purchasing Division Director may cancel any purchase or Contract upon 30 days written notice to the Vendor in accordance with West Virginia Code of State Rules § 148-1-7.16.2.
25. **WAIVER OF MINOR IRREGULARITIES:** The Director reserves the right to waive minor irregularities in bids or specifications in accordance with West Virginia Code of State Rules § 148-1-4.6.
26. **TIME:** Time is of the essence with regard to all matters of time and performance in this Contract.
27. **APPLICABLE LAW:** This Contract is governed by and interpreted under West Virginia law without giving effect to its choice of law principles. Any information provided in specification manuals, or any other source, verbal or written, which contradicts or violates the West Virginia Constitution, West Virginia Code or West Virginia Code of State Rules is void and of no effect.
28. **COMPLIANCE:** Vendor shall comply with all applicable federal, state, and local laws, regulations and ordinances. By submitting a bid, Vendors acknowledge that they have reviewed, understand, and will comply with all applicable law.
29. **PREVAILING WAGE:** On any contract for the construction of a public improvement, Vendor and any subcontractors utilized by Vendor shall pay a rate or rates of wages which shall not be less than the fair minimum rate or rates of wages (prevailing wage), as established by the West Virginia Division of Labor under West Virginia Code §§ 21-5A-1 et seq. and available at <http://www.sos.wv.gov/administrative-law/wagerates/Pages/default.aspx>. Vendor shall be responsible for ensuring compliance with prevailing wage requirements and determining when prevailing wage

requirements are applicable. The required contract provisions contained in West Virginia Code of State Rules § 42-7-3 are specifically incorporated herein by reference.

- 30. ARBITRATION:** Any references made to arbitration contained in this Contract, Vendor's bid, or in any American Institute of Architects documents pertaining to this Contract are hereby deleted, void, and of no effect.
- 31. MODIFICATIONS:** This writing is the parties' final expression of intent. Notwithstanding anything contained in this Contract to the contrary, no modification of this Contract shall be binding without mutual written consent of the Agency, and the Vendor, with approval of the Purchasing Division and the Attorney General's office (Attorney General approval is as to form only). **No Change shall be implemented by the Vendor until such time as the Vendor receives an approved written change order from the Purchasing Division.**
- 32. WAIVER:** The failure of either party to insist upon a strict performance of any of the terms or provision of this Contract, or to exercise any option, right, or remedy herein contained, shall not be construed as a waiver or a relinquishment for the future of such term, provision, option, right, or remedy, but the same shall continue in full force and effect. Any waiver must be expressly stated in writing and signed by the waiving party.
- 33. SUBSEQUENT FORMS:** The terms and conditions contained in this Contract shall supersede any and all subsequent terms and conditions which may appear on any form documents submitted by Vendor to the Agency or Purchasing Division such as price lists, order forms, invoices, sales agreements, or maintenance agreements, and includes internet websites or other electronic documents. Acceptance or use of Vendor's forms does not constitute acceptance of the terms and conditions contained thereon.
- 34. ASSIGNMENT:** Neither this Contract nor any monies due, or to become due hereunder, may be assigned by the Vendor without the express written consent of the Agency, the Purchasing Division, the Attorney General's office (as to form only), and any other government agency or office that may be required to approve such assignments. Notwithstanding the foregoing, Purchasing Division approval may or may not be required on certain agency delegated or exempt purchases.
- 35. WARRANTY:** The Vendor expressly warrants that the goods and/or services covered by this Contract will: (a) conform to the specifications, drawings, samples, or other description furnished or specified by the Agency; (b) be merchantable and fit for the purpose intended; and (c) be free from defect in material and workmanship.
- 36. STATE EMPLOYEES:** State employees are not permitted to utilize this Contract for personal use and the Vendor is prohibited from permitting or facilitating the same.
- 37. BANKRUPTCY:** In the event the Vendor files for bankruptcy protection, the State of West Virginia may deem this Contract null and void, and terminate this Contract without notice.

38. **HIPAA BUSINESS ASSOCIATE ADDENDUM:** The West Virginia State Government HIPAA Business Associate Addendum (BAA), approved by the Attorney General, is available online at <http://www.state.wv.us/admin/purchase/vrc/hipaa.html> and is hereby made part of the agreement provided that the Agency meets the definition of a Covered entity (45 CFR §160.103) and will be disclosing Protected Health Information (45 CFR §160.103) to the Vendor. Additionally, the HIPAA Privacy, Security, Enforcement & Breach Notification Final Omnibus Rule was published on January 25, 2013. It may be viewed online at <http://www.gpo.gov/fdsys/pkg/FR-2013-01-25/pdf/2013-01073.pdf>. Any organization, that qualifies as the Agency's Business Associate, is expected to be in compliance with this Final Rule. For those Business Associates entering into contracts with a HIPAA Covered State Agency between January 25, 2013 and the release of the 2013 WV State Agency Business Associate Agreement, or September 23, 2013 (whichever is earlier), be advised that you will be required to comply with the 2013 WV State Agency Business Associate Agreement. For those Business Associates with contracts with a HIPAA Covered State Agency executed prior to January 25, 2013, be advised that upon renewal or modification, you will be required to comply with the 2013 WV State Agency Business Associate Agreement no later than September 22, 2014.
39. **CONFIDENTIALITY:** The Vendor agrees that it will not disclose to anyone, directly or indirectly, any such personally identifiable information or other confidential information gained from the Agency, unless the individual who is the subject of the information consents to the disclosure in writing or the disclosure is made pursuant to the Agency's policies, procedures, and rules. Vendor further agrees to comply with the Confidentiality Policies and Information Security Accountability Requirements, set forth in <http://www.state.wv.us/admin/purchase/privacy/default.html>.
40. **DISCLOSURE:** Vendor's response to the Solicitation and the resulting Contract are considered public documents and will be disclosed to the public in accordance with the laws, rules, and policies governing the West Virginia Purchasing Division. Those laws include, but are not limited to, the Freedom of Information Act found in West Virginia Code § 29B-1-1 et seq.

If a Vendor considers any part of its bid to be exempt from public disclosure, Vendor must so indicate by specifically identifying the exempt information, identifying the exemption that applies, providing a detailed justification for the exemption, segregating the exempt information from the general bid information, and submitting the exempt information as part of its bid but in a segregated and clearly identifiable format. Failure to comply with the foregoing requirements will result in public disclosure of the Vendor's bid without further notice. A Vendor's act of marking all or nearly all of its bid as exempt is not sufficient to avoid disclosure and WILL NOT BE HONORED. Vendor's act of marking a bid or any part thereof as "confidential" or "proprietary" is not sufficient to avoid disclosure and WILL NOT BE HONORED. In addition, a legend or other statement indicating that all or substantially all of the bid is exempt from disclosure is not sufficient to avoid disclosure and WILL NOT BE HONORED. Vendor will be required to defend any claimed exemption for nondisclosure in the event of an administrative or judicial challenge to the State's nondisclosure. Vendor must indemnify the State for any costs incurred related to any exemptions claimed by Vendor. Any questions regarding the applicability of the various public records laws should be addressed to your own legal counsel prior to bid submission.

41. **LICENSING:** In accordance with West Virginia Code of State Rules §148-1-6.1.7, Vendor must be licensed and in good standing in accordance with any and all state and local laws and requirements by any state or local agency of West Virginia, including, but not limited to, the West Virginia Secretary of State's Office, the West Virginia Tax Department, West Virginia Insurance Commission, or any other state agency or political subdivision. Upon request, the Vendor must provide all necessary releases to obtain information to enable the Purchasing Division Director or the Agency to verify that the Vendor is licensed and in good standing with the above entities.
42. **ANTITRUST:** In submitting a bid to, signing a contract with, or accepting a Purchase Order from any agency of the State of West Virginia, the Vendor agrees to convey, sell, assign, or transfer to the State of West Virginia all rights, title, and interest in and to all causes of action it may now or hereafter acquire under the antitrust laws of the United States and the State of West Virginia for price fixing and/or unreasonable restraints of trade relating to the particular commodities or services purchased or acquired by the State of West Virginia. Such assignment shall be made and become effective at the time the purchasing agency tenders the initial payment to Vendor.
43. **VENDOR CERTIFICATIONS:** By signing its bid or entering into this Contract, Vendor certifies (1) that its bid was made without prior understanding, agreement, or connection with any corporation, firm, limited liability company, partnership, person or entity submitting a bid for the same material, supplies, equipment or services; (2) that its bid is in all respects fair and without collusion or fraud; (3) that this Contract is accepted or entered into without any prior understanding, agreement, or connection to any other entity that could be considered a violation of law; and (4) that it has reviewed this RFQ in its entirety; understands the requirements, terms and conditions, and other information contained herein. Vendor's signature on its bid also affirms that neither it nor its representatives have any interest, nor shall acquire any interest, direct or indirect, which would compromise the performance of its services hereunder. Any such interests shall be promptly presented in detail to the Agency.

The individual signing this bid on behalf of Vendor certifies that he or she is authorized by the Vendor to execute this bid or any documents related thereto on Vendor's behalf; that he or she is authorized to bind the Vendor in a contractual relationship; and that, to the best of his or her knowledge, the Vendor has properly registered with any State agency that may require registration.

44. **PURCHASING CARD ACCEPTANCE:** The State of West Virginia currently utilizes a Purchasing Card program, administered under contract by a banking institution, to process payment for goods and services. The Vendor must accept the State of West Virginia's Purchasing Card for payment of all orders under this Contract unless the box below is checked.

Vendor is not required to accept the State of West Virginia's Purchasing Card as payment for all goods and services.

45. **VENDOR RELATIONSHIP:** The relationship of the Vendor to the State shall be that of an independent contractor and no principal-agent relationship or employer-employee relationship is contemplated or created by this Contract. The Vendor as an independent contractor is solely liable for the acts and omissions of its employees and agents. Vendor shall be responsible for selecting,

supervising, and compensating any and all individuals employed pursuant to the terms of this Solicitation and resulting contract. Neither the Vendor, nor any employees or subcontractors of the Vendor, shall be deemed to be employees of the State for any purpose whatsoever. Vendor shall be exclusively responsible for payment of employees and contractors for all wages and salaries, taxes, withholding payments, penalties, fees, fringe benefits, professional liability insurance premiums, contributions to insurance and pension, or other deferred compensation plans, including but not limited to, Workers' Compensation and Social Security obligations, licensing fees, *etc.* and the filing of all necessary documents, forms and returns pertinent to all of the foregoing. Vendor shall hold harmless the State, and shall provide the State and Agency with a defense against any and all claims including, but not limited to, the foregoing payments, withholdings, contributions, taxes, Social Security taxes, and employer income tax returns.

46. **INDEMNIFICATION:** The Vendor agrees to indemnify, defend, and hold harmless the State and the Agency, their officers, and employees from and against: (1) Any claims or losses for services rendered by any subcontractor, person, or firm performing or supplying services, materials, or supplies in connection with the performance of the Contract; (2) Any claims or losses resulting to any person or entity injured or damaged by the Vendor, its officers, employees, or subcontractors by the publication, translation, reproduction, delivery, performance, use, or disposition of any data used under the Contract in a manner not authorized by the Contract, or by Federal or State statutes or regulations; and (3) Any failure of the Vendor, its officers, employees, or subcontractors to observe State and Federal laws including, but not limited to, labor and wage and hour laws.
47. **PURCHASING AFFIDAVIT:** In accordance with West Virginia Code § 5A-3-10a, all Vendors are required to sign, notarize, and submit the Purchasing Affidavit stating that neither the Vendor nor a related party owe a debt to the State in excess of \$1,000. The affidavit must be submitted prior to award, but should be submitted with the Vendor's bid. A copy of the Purchasing Affidavit is included herewith.
48. **ADDITIONAL AGENCY AND LOCAL GOVERNMENT USE:** This Contract may be utilized by and extends to other agencies, spending units, and political subdivisions of the State of West Virginia; county, municipal, and other local government bodies; and school districts ("Other Government Entities"). This Contract shall be extended to the aforementioned Other Government Entities on the same prices, terms, and conditions as those offered and agreed to in this Contract. If the Vendor does not wish to extend the prices, terms, and conditions of its bid and subsequent contract to the Other Government Entities, the Vendor must clearly indicate such refusal in its bid. A refusal to extend this Contract to the Other Government Entities shall not impact or influence the award of this Contract in any manner.
49. **CONFLICT OF INTEREST:** Vendor, its officers or members or employees, shall not presently have or acquire any interest, direct or indirect, which would conflict with or compromise the performance of its obligations hereunder. Vendor shall periodically inquire of its officers, members and employees to ensure that a conflict of interest does not arise. Any conflict of interest discovered shall be promptly presented in detail to the Agency.

50. REPORTS: Vendor shall provide the Agency and/or the Purchasing Division with the following reports identified by a checked box below:

- Such reports as the Agency and/or the Purchasing Division may request. Requested reports may include, but are not limited to, quantities purchased, agencies utilizing the contract, total contract expenditures by agency, etc.
- Quarterly reports detailing the total quantity of purchases in units and dollars, along with a listing of purchases by agency. Quarterly reports should be delivered to the Purchasing Division via email at purchasing.requisitions@wv.gov.

51. BACKGROUND CHECK: In accordance with W. Va. Code § 15-2D-3, the Director of the Division of Protective Services shall require any service provider whose employees are regularly employed on the grounds or in the buildings of the Capitol complex or who have access to sensitive or critical information to submit to a fingerprint-based state and federal background inquiry through the state repository. The service provider is responsible for any costs associated with the fingerprint-based state and federal background inquiry.

After the contract for such services has been approved, but before any such employees are permitted to be on the grounds or in the buildings of the Capitol complex or have access to sensitive or critical information, the service provider shall submit a list of all persons who will be physically present and working at the Capitol complex to the Director of the Division of Protective Services for purposes of verifying compliance with this provision.

The State reserves the right to prohibit a service provider's employees from accessing sensitive or critical information or to be present at the Capitol complex based upon results addressed from a criminal background check.

Service providers should contact the West Virginia Division of Protective Services by phone at (304) 558-9911 for more information.

52. PREFERENCE FOR USE OF DOMESTIC STEEL PRODUCTS: Except when authorized by the Director of the Purchasing Division pursuant to W. Va. Code § 5A-3-56, no contractor may use or supply steel products for a State Contract Project other than those steel products made in the United States. A contractor who uses steel products in violation of this section may be subject to civil penalties pursuant to W. Va. Code § 5A-3-56. As used in this section:

- a. "State Contract Project" means any erection or construction of, or any addition to, alteration of or other improvement to any building or structure, including, but not limited to, roads or highways, or the installation of any heating or cooling or ventilating plants or other equipment, or the supply of and materials for such projects, pursuant to a contract with the State of West Virginia for which bids were solicited on or after June 6, 2001.
- b. "Steel Products" means products rolled, formed, shaped, drawn, extruded, forged, cast, fabricated or otherwise similarly processed, or processed by a combination of two or more or

such operations, from steel made by the open heath, basic oxygen, electric furnace, Bessemer or other steel making process.

The Purchasing Division Director may, in writing, authorize the use of foreign steel products if:

- a. The cost for each contract item used does not exceed one tenth of one percent (.1%) of the total contract cost or two thousand five hundred dollars (\$2,500.00), whichever is greater. For the purposes of this section, the cost is the value of the steel product as delivered to the project; or
- b. The Director of the Purchasing Division determines that specified steel materials are not produced in the United States in sufficient quantity or otherwise are not reasonably available to meet contract requirements.

53. PREFERENCE FOR USE OF DOMESTIC ALUMINUM, GLASS, AND STEEL: In Accordance with W. Va. Code § 5-19-1 et seq., and W. Va. CSR § 148-10-1 et seq., for every contract or subcontract, subject to the limitations contained herein, for the construction, reconstruction, alteration, repair, improvement or maintenance of public works or for the purchase of any item of machinery or equipment to be used at sites of public works, only domestic aluminum, glass or steel products shall be supplied unless the spending officer determines, in writing, after the receipt of offers or bids, (1) that the cost of domestic aluminum, glass or steel products is unreasonable or inconsistent with the public interest of the State of West Virginia, (2) that domestic aluminum, glass or steel products are not produced in sufficient quantities to meet the contract requirements, or (3) the available domestic aluminum, glass, or steel do not meet the contract specifications. This provision only applies to public works contracts awarded in an amount more than fifty thousand dollars (\$50,000) or public works contracts that require more than ten thousand pounds of steel products.

The cost of domestic aluminum, glass, or steel products may be unreasonable if the cost is more than twenty percent (20%) of the bid or offered price for foreign made aluminum, glass, or steel products. If the domestic aluminum, glass or steel products to be supplied or produced in a "substantial labor surplus area", as defined by the United States Department of Labor, the cost of domestic aluminum, glass, or steel products may be unreasonable if the cost is more than thirty percent (30%) of the bid or offered price for foreign made aluminum, glass, or steel products.

This preference shall be applied to an item of machinery or equipment, as indicated above, when the item is a single unit of equipment or machinery manufactured primarily of aluminum, glass or steel, is part of a public works contract and has the sole purpose or of being a permanent part of a single public works project. This provision does not apply to equipment or machinery purchased by a spending unit for use by that spending unit and not as part of a single public works project.

All bids and offers including domestic aluminum, glass or steel products that exceed bid or offer prices including foreign aluminum, glass or steel products after application of the preferences provided in this provision may be reduced to a price equal to or lower than the lowest bid or offer price for foreign aluminum, glass or steel products plus the applicable preference. If the reduced bid or offer prices are made in writing and supersede the prior bid or offer prices, all bids or offers, including the reduced bid or offer prices, will be reevaluated in accordance with this rule.

REQUEST FOR QUOTATION
DEFK13022 – (5) Sub-Compact Diesel Tractors & Attachments

SPECIFICATIONS

1. **PURPOSE AND SCOPE:** The West Virginia Purchasing Division is soliciting bids on behalf of the West Virginia Army Reserve National Guard's Division of Engineering & Facilities to establish a contract for the one time purchase of 5 (five) Sub-compact tractors, with 60" Mower Decks (mid mount) and 60" Snow Dozer Blade (front mount).
2. **DEFINITIONS:** The terms listed below shall have the meanings assigned to them below. Additional definitions can be found in section 2 of the General Terms and Conditions.
 - 2.1 "Contract Item" means sub-compact diesel tractor, mower deck, and snow dozer blade
 - 2.2 "Bid Evaluation Page" means the page upon which Vendor should list its proposed price for the Contract Items in the manner requested by thereon. The Contract Item is either included on the last page of this RFQ or attached hereto as Exhibit A.
 - 2.3 "RFQ" means the official RFQ published by the Purchasing Division and identified as DEFK13022.
3. **GENERAL REQUIREMENTS:**

- 3.1 **Mandatory Contract Item Requirements:** Contract Item must meet or exceed the mandatory requirements listed below.

3.1.1 **Contract Item #1 Sub-Compact Diesel Tractor** John Deere 1025R

3.1.1.1 Must be equal to 2013 or newer Yanmar Model Sc2400 Sub-Compact Tractor. If bidding an alternate sub-compact tractor, Vendor must clearly identify alternate tractor and provide manufacturer's specifications, industry literature, and/or any other relevant documentation that demonstrates the alternate tractor meets the following mandatory specifications.

3.1.1.2 24 HP Diesel minimum / max 30 HP Diesel Engine

3.1.1.3 PTO HP (Hyd) 16.5

3.1.1.4 Number of Cylinders (3)

3.1.1.5 Bore and Stroke (72 x 74 mm)

3.1.1.6 Total Displacement (55.1 cu. In)

3.1.1.7 Ignition Type (Indirect Injection)

3.1.1.8 Lubrication (Full Pressure)

3.1.1.9 Oil Filter (Spin on / Full Flow).

3.1.1.10 Air Cleaner (4" Single Ply)

3.1.1.11 Preheat System (Glow Plug)

000000

REQUEST FOR QUOTATION
DEFK13022 – (5) Sub-Compact Diesel Tractors & Attachments

- 3.1.1.12 Alternator (40 amp)
- 3.1.1.13 Fuel Tank (5.8 Gallon)
- 3.1.1.14 Control valve (4 way up, down right and left angle)
- 3.1.1.15 Cooling System (3.4 Quart)
- 3.1.1.16 Engine oil (2.5 Quart)
- 3.1.1.17 Transmission Type (Hydrostatic)
- 3.1.1.18 Number of ranges (2 shift on the go)
- 3.1.1.19 4WD Operations (2WD & 4WD Selectable)
- 3.1.1.20 Cruise control (Selectable)
- 3.1.1.21 Rear Differential Lock (Foot Pedal Operation)
- 3.1.1.22 PTO Type (Independent)
- 3.1.1.23 Brake (Wet Disc)
- 3.1.1.24 Pump (Gear/ Trochoid)
- 3.1.1.25 Steering/SCV/3-Pt hitch
- 3.1.1.26 Transmission/hydraulic PTO
- 3.1.1.27 3- Point Hitch (Limited Category 1)
- 3.1.1.28 3-Point Lift Capacity at 24" behind (661 lbs)
- 3.1.1.29 Wheelbase (55.1 ")
- 3.1.1.30 Width (44.5" w/R4)
- 3.1.1.31 Overall length w/o 3-pt hitch (95.5 ")
- 3.1.1.32 Ground Clearance (7.5" w/R4)
- 3.1.1.33 Weight w/ROPS & Fluids(1,280 lbs)
- 3.1.1.34 Tire Size Front Industrial/Bar/Turf (18" x8.5" -10)
- 3.1.1.35 Tire Size Rear Industrial/Bar/Turf (26" x 12.0" -12)
- 3.1.1.36 Warranty Residential/Commercial (Tractor 2 Year or 2,000-hour limited. Engine/Drivetrain 3 year or 2,000 hour limited warranty)

3.1.2 Contract Item #2 MID- MOUNT MOWER

- 3.1.2.1 Type (Side Discharge)
- 3.1.2.2 Mounting method (Suspended linkage)
- 3.1.2.3 Lift linkage type (Parallel Suspended)
- 3.1.2.4 Transport Height (6")
- 3.1.2.5 Number of Blades (3)
- 3.1.2.6 Cutting Width (60")
- 3.1.2.7 Cutting Height (1 " – 4")
- 3.1.2.8 Height Adjustment Increment (Ground contouring gauge wheels)
- 3.1.2.9 Deck Thickness (11 gauge reinforced edge)

3.1.3 Contract Item #3 SNOW DOZER BLADE

- 3.1.3.1 Cutting Depth (5")
- 3.1.3.2 Reversible Cutting Edge (Standard)
- 3.1.3.3 Cutting Thickness (0.25")
- 3.1.3.4 Adjustable Skid Shoes (Standard)
- 3.1.3.5 Cutting Width Straight (60")
- 3.1.3.6 Angle Range (30 degrees)
- 3.1.3.7 Cutting Width at 30 degree angle (51")
- 3.1.3.8 Hydraulic Angle (Standard)
- 3.1.3.9 Cutting Edge Height (3")
- 3.1.3.10 Ramp Angle (15 Degrees)
- 3.1.3.11 Blade Lift Height (11")
- 3.1.3.12 Overall Blade Height (19.5")
- 3.1.3.13 Trip Springs (Dual)
- 3.1.3.14 Front Hitch(Quick Attach Required)
- 3.1.3.15 Mold Board (Heavy Duty)

4. CONTRACT AWARD

4.1 Contract Award: The Contract is intended to provide Agencies with a purchase price for the Contract Items. The Contract shall be awarded to the Vendor that provides the Contract Items meeting the required specifications for the lowest overall total cost as shown on the Pricing Pages.

4.2 Bid Evaluation Page: Vendor should complete the Bid Evaluation Page by entering the unit price of each contract item in the unit price column and extending the line item price to reflect the quantity times the unit price. The line item prices should be totaled and entered in the total bid price space at the bottom of the bid schedule. Vendor should then complete all the vendor information sections and then sign and date the bid evaluation page. Vendor should complete the Bid Evaluation Page in full as failure to complete the Bid Evaluation Page in its entirety may result in Vendor's bid being disqualified.

Notwithstanding the foregoing, the Purchasing Division may correct errors as it deems appropriate. Vendor should type or electronically enter the information into the Bid Evaluation Page to prevent errors in the evaluation.

5. PAYMENT:

5.1 Payment: Vendor shall accept payment in accordance with the payment procedures of the State of West Virginia. Methods of acceptable payment must include the West Virginia Purchasing Card. Payment in advance is not permitted under this Contract.

6. DELIVERY AND RETURN:

- 6.1 Shipment and Delivery:** Vendor shall ship the Contract Items immediately after being awarded this Contract and receiving a purchase order or notice to proceed. Vendor shall deliver the Contract Items within 30 working days after receiving a purchase order or notice to proceed. Contract Items must be delivered to Agency at:

West Virginia Army National Guard
Div. Engineering & Facilities
Attn: Tim Hersman
1707 Coonskin Drive
Charleston, WV 25311

- 6.2 Late Delivery:** The Agency placing the order under this Contract must be notified in writing if the shipment of the Contract Items will be delayed for any reason. Any delay in delivery that could cause harm to an Agency will be grounds for cancellation of the Contract, and/or obtaining the Contract Items from a third party.

Any Agency seeking to obtain the Contract Items from a third party under this provision must first obtain approval of the Purchasing Division.

- 6.3 Delivery Payment/Risk of Loss:** Vendor shall deliver the Contract Items F.O.B. destination to the Agency's location.
- 6.4 Return of Unacceptable Items:** If the Agency deems the Contract Items to be unacceptable, the Contract Items shall be returned to Vendor at Vendor's expense and with no restocking charge. Vendor shall either make arrangements for the return within five (5) days of being notified that items are unacceptable, or permit the Agency to arrange for the return and reimburse Agency for delivery expenses. If the original packaging cannot be utilized for the return, Vendor will supply the Agency with appropriate return packaging upon request. All returns of unacceptable items shall be F.O.B. the Agency's location. The returned product shall either be replaced, or the Agency shall receive a full credit or refund for the purchase price, at the Agency's discretion.
- 6.5 Return Due to Agency Error:** Items ordered in error by the Agency will be returned for credit within 30 days of receipt, F.O.B. Vendor's location. Vendor shall not charge a restocking fee if returned products are in a resalable condition. Items shall be deemed to be in a resalable condition if they are unused and in the original packaging. Any restocking fee for items not in a resalable condition shall be the lower of the Vendor's customary restocking fee or 5% of the total invoiced value of the returned items.

| | |
|--|------------------------------|
| Manufacturer | John Deere |
| MODEL | 1025R |
| SERIAL NUMBERS | --- |
| Engine | |
| Manufacturer | Yanmar 3TNV80 |
| Engine power 97/68/EC rated power (gross), hp (kW) | 24.2 (17.8), PS |
| PTO power - Gear transmission, hp (kW) | --- |
| PTO power - Hydrostatic transmission, hp (kW) | 18 (13.4) per SAE |
| Rated engine speed, rpm | 3200 |
| Type | Diesel |
| Operating range | 1575-3370 |
| Aspiration | Natural |
| Cylinders/displacement, cu in. (L) | 3 / 68 (1.115) |
| Cylinder liners | Cast-In-Block |
| Bore and stroke, mm (in.) | 76x82 (2.99x3.23) |
| Compression ratio | 23.5:1 |
| Lubrication | Pressurized |
| Cooling system | Water pump |
| Air cleaner | Dry type with safety element |
| Engine shutoff | Key switch |
| Engine torque @ rated speed, lb-ft (N/m) | 40.7 (55.2) |
| Fuel tank capacity (open-station; cab), U.S. gal. (L) | 5.6 (21.2) |
| Electrical | |
| Type | 12V |
| Battery size (CCA) | 500 |
| Alternator (12-V), amp | 40 |
| Starter size, hp (kW) | 1.6 (1.2) |
| Fuel system | |
| Type | Diesel |
| Injection pump type | Indirect Injection |
| Consumption at 100% load, U.S. gal./hr (L/hr)* | 1.4 (5.3) |
| Fuel consumption rate should be used for comparison purposes only. | --- |
| Transmission | |
| Standard transmission; forward/reverse | Hydrostatic - 2 range |
| Optional transmission; forward/reverse | --- |
| Left-hand reverser | No |
| On-the-go shifting (yes/no/partial) | N/A |
| Direction reverser; forward/reverse | No; Twin Touch Pedals |
| Final drive | Spur gear |
| Brakes | Wet disk (left hand pedal) |
| Steering | Power |
| Clutch, wet/dry | N/A |
| Clutch disk diameter wet clutch, in. (mm) | --- |
| Drawbar tongue weight capacity, lb (kg) | --- |
| Axle capacity (In operation) | --- |
| Front, lb (kg) | 1253 (568) |
| Rear, lb (kg) | 2078 (942) |
| Creeper | No |
| Hydraulics | |
| Type | Open Center |
| Pump rated output, gpm (L/min) | 6.3 (24) |
| Steering | 2.8 (10.8) |
| Implement | 3.5 (13.2) |
| Pump type | Gear |
| Maximum operating pressure (psi) | 2000 |
| Draft control type | Position Control |
| Remote control valves available | 2 |

| | |
|--|------------------------|
| 3-point hitch | |
| Type | Limited Cat. 1 |
| Lift capacity, 24-in. behind link arms, lb (kg) | 681 (309) |
| Lift capacity at lift link ends, lb (kg) | --- |
| Power take-off (PTO) | |
| Standard | Rear @ 540; Mid @ 2100 |
| Optional | --- |
| Control | Independent |
| Clutch | Wet disk |
| Brake (for mid and rear PTO) | Wet disk |
| Fluid capacities | |
| Fuel tank, gal. (L) | 5.6 (21.2) |
| Cooling system (includes coolant bottle), qt (L) | 2.9 (2.7) |
| Crankcase with filter, qt (L) | 3.9 (3.7) |
| Transmission and hydraulic system gear, gal. (L) | --- |
| Transmission and hydraulic system hydrostatic, gal. (L) | 3.25 (12.3) |
| Front axle gearcase (MFWD axle), gal. (L) | .625 (2.5) |
| Final drive | |
| Type | Spur Gear |
| Engage on-the-go rear differential lock | Yes |
| Operator station | |
| Rollover protection structure | OSHA, SAE, ASAE, EEC |
| Type | Foldable |
| Platform - Flat/straddle | One-piece semi flat |
| Gear shift location - Console/floor | Left Hand Side |
| Cab | |
| Compliance | --- |
| Visibility | --- |
| Air conditioning, temperature differential | --- |
| Doors | --- |
| Platform type | --- |
| Noise rating | --- |
| Seat suspension system | --- |
| 2WD dimensions | |
| Wheelbase, in. (mm) | --- |
| Front tread range, in. (mm) | --- |
| Rear tread range, in. (mm) | --- |
| Minimum rear tread setting, in. (mm) | --- |
| Front axle clearance, in. (mm) | --- |
| Turning radius with brakes, ft (m) | --- |
| Turning radius without brakes, ft (m) | --- |
| Unballasted operating weight, lb (kg) | --- |
| Approximate shipping weight (open-station; cab), lb (kg) | --- |
| MFWD Dimensions | |
| Wheelbase, in. (mm) | 57.1 (1450) |
| Front tread range, in. (mm) | 36.1 (918) |
| Front axle clearance, in. (mm) | 7.7 (195) |
| Turning radius with brakes, ft (m) | --- |
| Turning radius without brakes, ft (m) | 7.4 (2.25) |
| Limited slip differential | --- |
| Unballasted operating weight, lb (kg) | --- |
| Approximate shipping weight (open-station; cab), lb (kg) | 1444 (655) |
| Standard tires | |
| 2WD | --- |
| Front | --- |
| Rear | --- |
| MFWD | --- |
| Front | 18X8.5-10 R4 |
| Rear | 26X12-12 R4 |

Miscellaneous

| | |
|---------------------------|----------|
| Underhood muffler | Yes |
| Joystick SCV control | Yes |
| Inboard planetary | No |
| Axle type | Flanged |
| Brakes - Type and control | Wet Disk |

Specifications

Print



| | 54D AutoConnect™ | 60D 7-Iron™ AutoConnect |
|--------------------------------------|-------------------------------|--------------------------------|
| Compatibility | 1023E, 1025R, and 1026R | 1023E, 1025R, and 1026R |
| Cutting width | 137 cm (54 in.) | 152 cm (60 in.) |
| Overall width, deflector up | 152 cm (60 in.) | 159 cm (62.5 in.) |
| Overall width, deflector down | 174 cm (68.5 in.) | 185 cm (73 in.) |
| Number of blades | 3 | 3 |
| Blade length | 48.5 cm (19.1 in.) | 53.5 cm (21.1 in.) |
| Blade thickness | 0.63 cm (0.25 in.) | 0.63 cm (0.25 in.) |
| Spindles (diameter) | 2 cm (0.787 in.) | 2.54 cm (1 in.) |
| Gauge wheel size (front) | 12.7 cm (5 in.) | 12.7 cm (5 in.) |
| Gauge wheel size (rear) | 12.7 cm (5 in.) | 12.7 cm (5 in.) |
| Deck thickness | 10 gauge | 7 gauge |
| Weight (approximately) | 89 kg (197 lb) | 117 kg (258 lb) |
| Blade tip speed (at 2600 rpm) | 16,751 fpm | 15,437 fpm |
| Mulching | Optional | Optional |
| Cutting height* | 2.54 to 10.16 cm (1 to 4 in.) | 2.54 to 10.16 cm (1 to 4 in.) |

* Cutting height varies depending on tractor and tire combination.

Product features are based on published information at the time of publication and are subject to change without notice. All trademarked terms, including John Deere, the leaping deer symbol and the colors green and yellow used herein are the property of Deere & Company, unless otherwise noted. Availability of products, product features, and other content on this site may vary by model and geographic region.

Engine horsepower and torque information are provided by the engine manufacturer to be used for comparison purposes only. Actual operating horsepower and torque will be less. Refer to the engine manufacturer's Web site for additional information.

Copyright © 1994-2013 Deere & Company. All Rights Reserved.

Specifications[Print](#)**1372-mm (54-in.) Quick-Hitch Front Blade**

| | |
|--|---|
| Cutting width: | |
| Blade straight | 1372 mm (54 in.) |
| Blade angled 15 degrees | 1325 mm (52-3/16 in.) |
| Blade angled 27 degrees | 1222 mm (48-1/8 in.) |
| Angling positions: | |
| Right and left | 0 degrees to 27 degrees |
| Range of lift: | |
| Above ground line - garden tractors | 280 mm (11 in.) |
| Below ground line - garden tractors | 90 mm (3-1/2 in.) |
| Above ground line - compact utility tractors | 280 mm (11 in.) (2025R, 2032R, 2320-2720)* 203 mm (8 in.) (2305)* |
| Below ground line - compact utility tractors | 38 mm (1.5 in.) (2025R, 2032R, 2320-2720)* 90 mm (3-1/2 in.) (2305)* |
| Blade skid shoes | Eight position |
| Material thickness: | |
| Blade | 3.05 mm (0.12 in.) |
| Replaceable scraper edge | 4.76 mm (0.188 in.) |
| Blade trip | Spring trip |
| Blade float | Hydraulic |
| Approximate weight | 23 kg (50 lb) |

**NOTE: Range of lift is approximate, and varies per model.*

[Provide feedback about this page](#)

Last Updated : 11-Apr-2013

Product features are based on published information at the time of publication and are subject to change without notice. All trademarked terms, including John Deere, the leaping deer symbol and the colors green and yellow used herein are the property of Deere & Company, unless otherwise noted. Availability of products, product features, and other content on this site may vary by model and geographic region.

Engine horsepower and torque information are provided by the engine manufacturer to be used for comparison purposes only. Actual operating horsepower and torque will be less. Refer to the engine manufacturer's Web site for additional information.

Copyright © 1994-2013 Deere & Company. All Rights Reserved.

US / Canada

Sales Manual

Configurator JDQuote2 Pathways

[Home](#)[Announcements](#)[Archives](#)[Attachments Search](#)[Help](#)[Feedback](#)[Print to PDF](#)[Turf & Utility Sales Manual](#) > [Model Year 2013 Blades-Brooms-Blowers](#) > [54-in. QH Blade](#)

Model Year 2013 Blades-Brooms- Blowers

* 54-in. QH Blade

- Base Equipment
- Configurator
- Attachments

* 44-in. Blade X300

* 44-in. Blade (LT)

* 44-in. Blade

LX/GT/GX

* 46-in. Blade

* 48-in. Blade X500

* 48-in. Blade GT/GX

* 40-in. Shovel

* 54-in. Shovel

* 44-in. Blower 100

* 44-in. Blower X

* 47-in. Blower M-T

* 47-in. QH Blower

* 54-in. QH Blower

* 42-in. Thrower

* 52-in. Broom

* 60-in. HD Broom

54-in. Quick-Hitch Front Blade

The 54-in. (137-cm) Front Blade is excellent for moving snow, gravel, dirt, sand, or other loose material. It can be hydraulically angled up to 27 degrees right or left or used in the straight-ahead position.

The front quick-hitch mounting system allows for tool-free change between the front blade, rotary broom, and snow blower on garden and small-chassis tractors.

The 54-in. (137-cm) Front Blade is compatible with the following tractors:

- X700 Series Tractors, X400 and X500 Series Heavy-Duty Garden Tractors, and 425, 445, and 455 Tractors
- 1023E, 1025R, 1026R, 2305, 2025R, 2032R, 2320, 2520, 2720, 2210, 4010, 4110, 4115, and 4100 Tractors
- 318, 322, 332, 420, and 430 Tractors (subject to the availability of mounting parts)

Not compatible with:

- X500 Series Multi-Terrain Tractors
- 320, 325, 335, 345, 355D, and GX300 Tractors



Key Features

[Heavy-duty construction gives long life](#)[Breakaway feature](#)[Adjustable skid shoes](#)[Front quick-hitch mounting system](#)[Hydraulic lift and angling](#)[Angling cylinder](#)[Specifications](#)

Supplemental Information/Compatibility

[Tractor compatibility and requirements](#)[Equipment compatibility chart - cuts](#)[Operator's manual](#)

Product features are based on published information at the time of publication and are subject to change without notice. All trademarked terms, including John Deere, the leaping deer symbol and the colors green and yellow used herein are the property of Deere & Company, unless otherwise noted. Availability of products, product features, and other content on this site may vary by model and geographic region.

Engine horsepower and torque information are provided by the engine manufacturer to be used for comparison purposes only. Actual operating horsepower and torque will be less. Refer to the engine manufacturer's Web site for additional information.

Copyright © 1994-2013 Deere & Company. All Rights Reserved.

Configurator JDQuote2 Pathways

US / Canada

Sales Manual

[Home](#)[Announcements](#)[Archives](#)[Attachments Search](#)[Help](#)[Feedback](#)[Print to PDF](#)[Turf & Utility Sales Manual](#) > [2013 Model Year Mowers and Material Collection](#) > **60D (1023E, 1025R, 1026R)**

2013 Model Year Mowers and Material Collection

- 60D (1023E, 1025R, 1026R)

- Base Equipment
- Configurator
- Attachments

- 54C (2305, 2210)

- 62C (2305, 2210)

- 54D (2025R, 2320)

- 54D (1023E, 1025R, 1026R)

- 62D (2025R, 2320, 2520, 2032R, 2720)

- 60D (3120-3720)

- 72D (3120-3720)

- 72-in. Mid and 7-Iron

- 3-Bag Power Flow MCS

60D 7-Iron AutoConnect Mid-Mount Mower

The 60D 7-Iron™ AutoConnect™ Mid-Mount Mower decks are the next generation in ease-of-use and attachment technology. The AutoConnect mid-mount mower fits the 1023E, 1025R, and 1026R Sub-Compact Utility Tractors.

These next generation decks are designed to be installed without leaving the tractor seat. Customers will be able to drive over the top of the mower as the mower deck automatically connects to the tractor, and with option of the automatic power take-off (PTO) connection, the PTO shaft automatically hooks up. The operator will only need to leave the tractor seat to set the gauge wheels in place.

The AutoConnect mid-mount mower is also compatible with loader, backhoes, and rear attachments. Front and rear attachments can stay on when mowing and vice versa.

NOTE: Manual PTO connection is standard with the 60D AutoConnect Mid-Mount Mowers. AutoConnect PTO connection option available when ordering.

60D 7-Iron AutoConnect deck shown on 1026R Tractor.

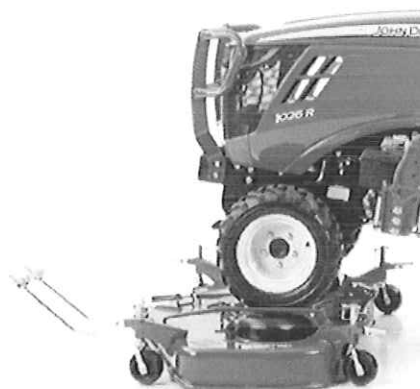
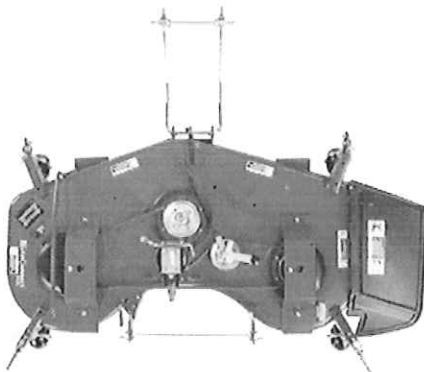

Marketing Tools

[Video](#)

Key Features

[Installation and removal](#)[Mid-mower lift system](#)[Compatible with front/rear implements](#)[Mid-power take-off \(PTO\) driven](#)[Mower height adjustment](#)[Service and durability](#)

Supplemental Information/Compatibility

[Specifications](#)[Tractor equipment compatibility](#)[Equipment compatibility chart \(current tractors\)](#)[Operator's manual](#)[Operational videos](#)

Product features are based on published information at the time of publication and are subject to change without notice. All trademarked terms, including John Deere, the leaping deer symbol and the colors green and yellow used herein are the property of Deere & Company, unless otherwise noted. Availability of products, product features, and other content on this site may vary by model and geographic region.

Engine horsepower and torque information are provided by the engine manufacturer to be used for comparison purposes only. Actual operating horsepower and torque will be less. Refer to the engine manufacturer's Web site for additional information.

Copyright © 1994-2013 Deere & Company. All Rights Reserved.

Configurator JDQuote2 Pathways

US / Canada

Sales Manual

[Home](#)[Announcements](#)[Archives](#)[Attachments Search](#)[Help](#)[Feedback](#)[Print to PDF](#)[Turf & Utility Sales Manual](#) > [2013 Model Year Mowers and Material Collection](#) > **60D (1023E, 1025R, 1026R)**

2013 Model Year Mowers and Material Collection

* [60D \(1023E, 1025R, 1026R\)](#)

- [Base Equipment](#)
- [Configurator](#)
- [Attachments](#)

* [54C \(2305, 2210\)](#)* [62C \(2305, 2210\)](#)* [54D \(2025R, 2320\)](#)* [54D \(1023E, 1025R, 1026R\)](#)* [62D \(2025R, 2320, 2520, 2032R, 2720\)](#)* [60D \(3120-3720\)](#)* [72D \(3120-3720\)](#)* [72-in. Mid and 7-Iron](#)* [3-Bag Power Flow MCS](#)

60D 7-Iron AutoConnect Mid-Mount Mower

The 60D 7-Iron™ AutoConnect™ Mid-Mount Mower decks are the next generation in ease-of-use and attachment technology. The AutoConnect mid-mount mower fits the 1023E, 1025R, and 1026R Sub-Compact Utility Tractors.

These next generation decks are designed to be installed without leaving the tractor seat. Customers will be able to drive over the top of the mower as the mower deck automatically connects to the tractor, and with option of the automatic power take-off (PTO) connection, the PTO shaft automatically hooks up. The operator will only need to leave the tractor seat to set the gauge wheels in place.

The AutoConnect mid-mount mower is also compatible with loader, backhoes, and rear attachments. Front and rear attachments can stay on when mowing and vice versa.

NOTE: Manual PTO connection is standard with the 60D AutoConnect Mid-Mount Mowers. AutoConnect PTO connection option available when ordering.

60D 7-Iron AutoConnect deck shown on 1026R Tractor.

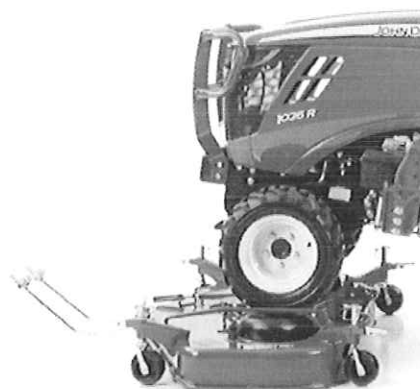
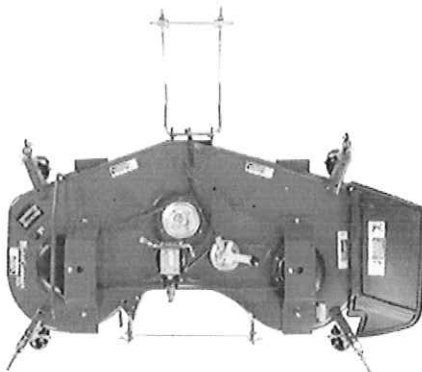

Marketing Tools

[Video](#)

Key Features

[Installation and removal](#)[Mid-mower lift system](#)[Compatible with front/rear implements](#)[Mid-power take-off \(PTO\) driven](#)[Mower height adjustment](#)[Service and durability](#)

Supplemental Information/Compatibility

[Specifications](#)[Tractor equipment compatibility](#)[Equipment compatibility chart \(current tractors\)](#)[Operator's manual](#)[Operational videos](#)

Product features are based on published information at the time of publication and are subject to change without notice. All trademarked terms, including John Deere, the leaping deer symbol and the colors green and yellow used herein are the property of Deere & Company, unless otherwise noted. Availability of products, product features, and other content on this site may vary by model and geographic region.

Engine horsepower and torque information are provided by the engine manufacturer to be used for comparison purposes only. Actual operating horsepower and torque will be less. Refer to the engine manufacturer's Web site for additional information.

Copyright © 1994-2013 Deere & Company. All Rights Reserved.



JOHN DEERE

Quote Id: 8234255

June 11, 2013

WV ARMORY

, WV

David A Mills
304-736-2120
BRIDGEPORT EQUIPMENT & TOOL



Quote Id: 8234255

Quote Summary

Prepared For:
WV ARMORY
, WV
Home: 304-3416368

Prepared By:
David A Mills
BRIDGEPORT EQUIPMENT &
TOOL
6777 MERRITTS CREEK
ROAD
HUNTINGTON, WV 25702
Phone: 304-736-2120
Mobile: 740-645-6650
dmills@bridgeportequip.com

Quote Id: 8234255
Created On: June 11, 2013
Last Modified On: June 24, 2013
Expiration Date: June 28, 2013

| Equipment Summary | Suggested List | Selling Price | Qty | Extended |
|---|----------------|---------------|-----|---------------------|
| JOHN DEERE (MY2013) 1025R Sub-Compact Utility Tractor (18 PTO hp) | \$ 13,733.50 | \$ 9,616.17 X | 1 = | \$ 9,616.17 |
| JOHN DEERE 60D 7-Iron Mid Mount Side Discharge Mower (For 1023E, 1025R, 1026R Tractors) | \$ 2,555.46 | \$ 1,904.80 X | 1 = | \$ 1,904.80 |
| JOHN DEERE 54 In. Quick-Hitch Front Blade (For X400/X500 HDGT's, X700's, 425-455, 1023E, 1025R, 1026R, 2210, 2305, 2025R, 2032R, 2320, 2520, 2720, 4010, 4100, 4110 and 4115 Tractors) | \$ 1,647.36 | \$ 1,248.72 X | 1 = | \$ 1,248.72 |
| Equipment Total | | | | \$ 12,769.69 |

NOTE Our blade is
54" wide not 60"

Quote Summary

| | |
|--------------------|---------------------|
| Equipment Total | \$ 12,769.69 |
| SubTotal | \$ 12,769.69 |
| Total | \$ 12,769.69 |
| Down Payment | (0.00) |
| Rental Applied | (0.00) |
| Balance Due | \$ 12,769.69 |

Salesperson : X _____

Accepted By : X _____



JOHN DEERE

Selling Equipment

Quote Id: 8234255

| JOHN DEERE (MY2013) 1025R Sub-Compact Utility Tractor (18 PTO hp) | | | | |
|--|--|------------|---------------------|-----------------------|
| Hours: | | | | Suggested List |
| Stock Number: | | | | \$ 13,733.50 |
| | | | | Selling Price |
| | | | | \$ 9,616.17 |
| Code | Description | Qty | Unit | Extended |
| 0284LV | (MY2013) 1025R Sub-Compact Utility Tractor (18 PTO hp) | 1 | \$ 13,361.00 | \$ 13,361.00 |
| Standard Options - Per Unit | | | | |
| 0409 | English North American Operator's Manual and Decal Kit | 1 | \$ 0.00 | \$ 0.00 |
| 5204 | 26X12-12 4PR Rear R4 Ind Bias | 1 | \$ 0.00 | \$ 0.00 |
| 6204 | 18X8.50-10 4PR Front R4 Ind Bias | 1 | \$ 0.00 | \$ 0.00 |
| Standard Options Total | | | | \$ 0.00 |
| Other Charges | | | | |
| | Setup | 1 | \$ 60.00 | \$ 60.00 |
| | Freight | 1 | \$ 312.50 | \$ 312.50 |
| Other Charges Total | | | | \$ 372.50 |
| Suggested Price | | | | \$ 13,733.50 |
| Customer Discounts | | | | |
| Customer Discounts Total | | | \$ -4,117.33 | \$ -4,117.33 |
| Total Selling Price | | | | \$ 9,616.17 |

| JOHN DEERE 60D 7-Iron Mid Mount Side Discharge Mower (For 1023E, 1025R, 1026R Tractors) | | | | |
|--|--|------------|-------------|-----------------------|
| Hours: | | | | Suggested List |
| Stock Number: | | | | \$ 2,555.46 |
| | | | | Selling Price |
| | | | | \$ 1,904.80 |
| Code | Description | Qty | Unit | Extended |
| 5320M | 60D 7-Iron Mid Mount Side Discharge Mower (For 1023E, 1025R, 1026R Tractors) | 1 | \$ 2,350.00 | \$ 2,350.00 |
| Standard Options - Per Unit | | | | |
| 1000 | Attaching Parts 1023E, 1025R, 1026R Tractors (Mechanical Mower Lift) | 1 | \$ 0.00 | \$ 0.00 |
| 2000 | Manual PTO Connection | 1 | \$ 0.00 | \$ 0.00 |
| Standard Options Total | | | | \$ 0.00 |
| Other Charges | | | | |
| | Setup | 1 | \$ 120.00 | \$ 120.00 |



JOHN DEERE

Selling Equipment

Quote Id: 8234255

| | | | |
|---------------------------------|---|-------------------|--------------------|
| Freight | 1 | \$ 85.46 | \$ 85.46 |
| Other Charges Total | | | \$ 205.46 |
| Suggested Price | | | \$ 2,555.46 |
| Customer Discounts | | | |
| Customer Discounts Total | | \$ -650.66 | \$ -650.66 |
| Total Selling Price | | | \$ 1,904.80 |

JOHN DEERE 54 In. Quick-Hitch Front Blade (For X400/X500 HDGT's, X700's, 425-455, 1023E, 1025R, 1026R, 2210, 2305, 2025R, 2032R, 2320, 2520, 2720, 4010, 4100, 4110 and 4115 Tractors)

Hours: Suggested List
 Stock Number: \$ 1,647.36

Selling Price
\$ 1,248.72

| Code | Description | Qty | Unit | Extended |
|-------|---|-----|-----------|-----------|
| 1491M | 54 In. Quick-Hitch Front Blade (For X400/X500 HDGT's, X700's, 425-455, 1023E, 1025R, 1026R, 2210, 2305, 2025R, 2032R, 2320, 2520, 2720, 4010, 4100, 4110 and 4115 Tractors) | 1 | \$ 515.00 | \$ 515.00 |

Standard Options - Per Unit

| | | | | |
|-------------------------------|--|---|-----------|------------------|
| 1008 | Front Quick-Hitch and Hydraulic Lift (1023E, 1025R, 1026R) | 1 | \$ 688.00 | \$ 688.00 |
| 2007 | Hydraulic Angling (1023E, 1025R, 1026R) | 1 | \$ 187.00 | \$ 187.00 |
| Standard Options Total | | | | \$ 875.00 |

Dealer Attachments

| | | | | |
|---------------------------------|---|---|----------|-----------------|
| LVB26046 | Front Attaching Support Kit (1023E, 1025R, 1026R) | 1 | \$ 67.41 | \$ 67.41 |
| Dealer Attachments Total | | | | \$ 67.41 |

Other Charges

| | | | |
|----------------------------|---|-----------|------------------|
| Setup | 1 | \$ 120.00 | \$ 120.00 |
| Freight | 1 | \$ 69.95 | \$ 69.95 |
| Other Charges Total | | | \$ 189.95 |

Suggested Price **\$ 1,647.36**

Customer Discounts

| | | | |
|---------------------------------|--|-------------------|--------------------|
| Customer Discounts Total | | \$ -398.64 | \$ -398.64 |
| Total Selling Price | | | \$ 1,248.72 |