



State of West Virginia
 Department of Administration
 Purchasing Division
 2019 Washington Street East
 Post Office Box 50130
 Charleston, WV 25305-0130

Solicitation

NUMBER
7013EC02

PAGE
1

ADDRESS CORRESPONDENCE TO ATTENTION OF:
ALAN CUMMINGS 304-558-2402

V
E
N
D
O
R

RFQ COPY
 TYPE NAME/ADDRESS HERE
Safety Caution Equipment Company
 P.O. Box 10040
 Charleston, WV 25357

S
H
I
P
T
O

DIVISION OF HIGHWAYS
 EQUIPMENT DIVISION
 ROUTE 33
 BRUSHY FORK ROAD
 BUCKHANNON, WV
 26201 304-472-1750

DATE PRINTED
04/25/2013

BID OPENING DATE: 06/05/2013 BID OPENING TIME: 1:30PM

LINE	QUANTITY	UOP	CAT. NO.	ITEM NUMBER	UNIT PRICE	AMOUNT
0001	1	EA		550-96	\$14,648.00	
TRAILER MOUNTED SOLAR MESSAGE BOARD						
REQUEST FOR QUOTATION (OPEN-END CONTRACT)						
THE WEST VIRGINIA STATE PURCHASING DIVISION FOR THE AGENCY, THE WEST VIRGINIA DIVISION OF HIGHWAYS, IS SOLICITING BIDS TO PROVIDE THE AGENCY WITH AN OPEN-END CONTRACT FOR FULL MATRIX TRAILER MOUNTED SOLAR POWERED MESSAGE BOARDS PER THE ATTACHED SPECIFICATIONS.						
***** THIS IS THE END OF RFQ 7013EC02 ***** TOTAL:						\$307,608.00

06/12/13 01:08:48 PM
 West Virginia Purchasing Division

SIGNATURE <i>Sara Matheny</i>	TELEPHONE 304-346-5521	DATE June 12, 2013
TITLE President	FEIN 56-0483991	ADDRESS CHANGES TO BE NOTED ABOVE

WHEN RESPONDING TO SOLICITATION, INSERT NAME AND ADDRESS IN SPACE ABOVE LABELED 'VENDOR'

INSTRUCTIONS TO VENDORS SUBMITTING BIDS

- 1. **REVIEW DOCUMENTS THOROUGHLY:** The attached documents contain a solicitation for bids. Please read these instructions and all documents attached in their entirety. These instructions provide critical information about requirements that if overlooked could lead to disqualification of a Vendor's bid. All bids must be submitted in accordance with the provisions contained in these instructions and the Solicitation. Failure to do so may result in disqualification of Vendor's bid.
- 2. **MANDATORY TERMS:** The Solicitation may contain mandatory provisions identified by the use of the words "must," "will," and "shall." Failure to comply with a mandatory term in the Solicitation will result in bid disqualification.
- 3. **PREBID MEETING:** The item identified below shall apply to this Solicitation.

A pre-bid meeting will not be held prior to bid opening.

A NON-MANDATORY PRE-BID meeting will be held at the following place and time:

A MANDATORY PRE-BID meeting will be held at the following place and time:

WVDOH- Equipment Division
 Route 33, Brushy Fork Road
 Buckhannon, WV 26201

05/16/13 - 10:00 A.M.

All Vendors submitting a bid must attend the mandatory pre-bid meeting. Failure to attend the mandatory pre-bid meeting shall result in disqualification of the Vendor's bid. No one person attending the pre-bid meeting may represent more than one Vendor.

An attendance sheet provided at the pre-bid meeting shall serve as the official document verifying attendance. The State will not accept any other form of proof or documentation to verify attendance. Any person attending the pre-bid meeting on behalf of a Vendor must list on the attendance sheet his or her name and the name of the Vendor he or she is representing. Additionally, the person attending the pre-bid meeting should include the Vendor's E-Mail address, phone number, and Fax number on the attendance sheet. It is the Vendor's responsibility to locate the attendance sheet and provide the required

information. Failure to complete the attendance sheet as required may result in disqualification of Vendor's bid.

All Vendors should arrive prior to the starting time for the pre-bid. Vendors who arrive after the starting time but prior to the end of the pre-bid will be permitted to sign in, but are charged with knowing all matters discussed at the pre-bid.

Questions submitted at least five business days prior to a scheduled pre-bid will be discussed at the pre-bid meeting if possible. Any discussions or answers to questions at the pre-bid meeting are preliminary in nature and are non-binding. Official and binding answers to questions will be published in a written addendum to the Solicitation prior to bid opening.

- 4. **VENDOR QUESTION DEADLINE:** Vendors may submit questions relating to this Solicitation to the Purchasing Division. Questions must be submitted in writing. All questions must be submitted on or before the date listed below and to the address listed below in order to be considered. A written response will be published in a Solicitation addendum if a response is possible and appropriate. Non-written discussions, conversations, or questions and answers regarding this Solicitation are preliminary in nature and are non-binding.

Question Submission Deadline:

Submit Questions to:

Fax:

Email:

- 5. **VERBAL COMMUNICATION:** Any verbal communication between the Vendor and any State personnel is not binding, including that made at the mandatory pre-bid conference. Only information issued in writing and added to the Solicitation by an official written addendum by the Purchasing Division is binding.

- 6. **BID SUBMISSION:** All bids must be signed and delivered by the Vendor to the Purchasing Division at the address listed below on or before the date and time of the bid opening. Any bid received by the Purchasing Division staff is considered to be in the possession of the Purchasing Division and will not be returned for any reason. The bid delivery address is:

Department of Administration, Purchasing Division
 2019 Washington Street East
 P.O. Box 50130,
 Charleston, WV 25305-0130

The bid should contain the information listed below on the face of the envelope or the bid may not be considered:

SEALED BID

BUYER: _____
 SOLICITATION NO.: _____
 BID OPENING DATE: _____
 BID OPENING TIME: _____
 FAX NUMBER: _____

In the event that Vendor is responding to a request for proposal, the Vendor shall submit one original technical and one original cost proposal plus convenience copies of each to the Purchasing Division at the address shown above. Additionally, the Vendor should identify the bid type as either a technical or cost proposal on the face of each bid envelope submitted in response to a request for proposal as follows:

BID TYPE: Technical
 Cost

7. **BID OPENING:** Bids submitted in response to this Solicitation will be opened at the location identified below on the date and time listed below. Delivery of a bid after the bid opening date and time will result in bid disqualification. For purposes of this Solicitation, a bid is considered delivered when time stamped by the official Purchasing Division time clock.

Bid Opening Date and Time:

06/05/2013 - 1:30 P.M.

Bid Opening Location:

Department of Administration, Purchasing Division
 2019 Washington Street East
 P.O. Box 50130,
 Charleston, WV 25305-0130

8. **ADDENDUM ACKNOWLEDGEMENT:** Changes or revisions to this Solicitation will be made by an official written addendum issued by the Purchasing Division. Vendor should acknowledge receipt of all addenda issued with this Solicitation by completing an Addendum Acknowledgment Form, a copy of which is included herewith. Failure to acknowledge addenda may result in bid disqualification. The addendum acknowledgement should be submitted with the bid to expedite document processing.
9. **BID FORMATTING:** Vendor should type or electronically enter the information onto its bid to prevent errors in the evaluation. Failure to type or electronically enter the information may result in bid disqualification.

GENERAL TERMS AND CONDITIONS:

1. **CONTRACTUAL AGREEMENT:** Issuance of a Purchase Order signed by the Purchasing Division Director, or his designee, and approved as to form by the Attorney General's office constitutes acceptance of this Contract made by and between the State of West Virginia and the Vendor. Vendor's signature on its bid signifies Vendor's agreement to be bound by and accept the terms and conditions contained in this Contract.

2. **DEFINITIONS:** As used in this Solicitation / Contract, the following terms shall have the meanings attributed to them below. Additional definitions may be found in the specifications included with this Solicitation / Contract.
 - 2.1 "Agency" or "Agencies" means the agency, board, commission, or other entity of the State of West Virginia that is identified on the first page of the Solicitation or any other public entity seeking to procure goods or services under this Contract.

 - 2.2 "Contract" means the binding agreement that is entered into between the State and the Vendor to provide the goods and services requested in the Solicitation.

 - 2.3 "Director" means the Director of the West Virginia Department of Administration, Purchasing Division.

 - 2.4 "Purchasing Division" means the West Virginia Department of Administration, Purchasing Division.

 - 2.5 "Purchase Order" means the document signed by the Agency and the Purchasing Division, and approved as to form by the Attorney General, that identifies the Vendor as the successful bidder and Contract holder.

 - 2.6 "Solicitation" means the official solicitation published by the Purchasing Division and identified by number on the first page thereof.

 - 2.7 "State" means the State of West Virginia and/or any of its agencies, commissions, boards, etc. as context requires.

 - 2.8 "Vendor" or "Vendors" means any entity submitting a bid in response to the Solicitation, the entity that has been selected as the lowest responsible bidder, or the entity that has been awarded the Contract as context requires.

3. **CONTRACT TERM; RENEWAL; EXTENSION:** The term of this Contract shall be determined in accordance with the category that has been identified as applicable to this Contract below:

Term Contract

Initial Contract Term: This Contract becomes effective on

 and extends for a period of year(s).

Renewal Term: This Contract may be renewed upon the mutual written consent of the Agency, and the Vendor, with approval of the Purchasing Division and the Attorney General's office (Attorney General approval is as to form only). Any request for renewal must be submitted to the Purchasing Division Director thirty (30) days prior to the expiration date of the initial contract term or appropriate renewal term. A Contract renewal shall be in accordance with the terms and conditions of the original contract. Renewal of this Contract is limited to successive one (1) year periods. Automatic renewal of this Contract is prohibited. Notwithstanding the foregoing, Purchasing Division approval is not required on agency delegated or exempt purchases. Attorney General approval may be required for vendor terms and conditions.

Reasonable Time Extension: At the sole discretion of the Purchasing Division Director, and with approval from the Attorney General's office (Attorney General approval is as to form only), this Contract may be extended for a reasonable time after the initial Contract term or after any renewal term as may be necessary to obtain a new contract or renew this Contract. Any reasonable time extension shall not exceed twelve (12) months. Vendor may avoid a reasonable time extension by providing the Purchasing Division Director with written notice of Vendor's desire to terminate this Contract 30 days prior to the expiration of the then current term. During any reasonable time extension period, the Vendor may terminate this Contract for any reason upon giving the Purchasing Division Director 30 days written notice. Automatic extension of this Contract is prohibited. Notwithstanding the foregoing, Purchasing Division approval is not required on agency delegated or exempt purchases, but Attorney General approval may be required.

- Fixed Period Contract:** This Contract becomes effective upon Vendor's receipt of the notice to proceed and must be completed within days.
- One Time Purchase:** The term of this Contract shall run from the issuance of the Purchase Order until all of the goods contracted for have been delivered, but in no event shall this Contract extend for more than one fiscal year.
- Other:** See attached.

4. **NOTICE TO PROCEED:** Vendor shall begin performance of this Contract immediately upon receiving notice to proceed unless otherwise instructed by the Agency. Unless otherwise specified, the fully executed Purchase Order will be considered notice to proceed
5. **QUANTITIES:** The quantities required under this Contract shall be determined in accordance with the category that has been identified as applicable to this Contract below.
- Open End Contract:** Quantities listed in this Solicitation are approximations only, based on estimates supplied by the Agency. It is understood and agreed that the Contract shall cover the quantities actually ordered for delivery during the term of the Contract, whether more or less than the quantities shown.
- Service:** The scope of the service to be provided will be more clearly defined in the specifications included herewith.
- Combined Service and Goods:** The scope of the service and deliverable goods to be provided will be more clearly defined in the specifications included herewith.
- One Time Purchase:** This Contract is for the purchase of a set quantity of goods that are identified in the specifications included herewith. Once those items have been delivered, no additional goods may be procured under this Contract without an appropriate change order approved by the Vendor, Agency, Purchasing Division, and Attorney General's office.
6. **PRICING:** The pricing set forth herein is firm for the life of the Contract, unless specified elsewhere within this Solicitation/Contract by the State. A Vendor's inclusion of price adjustment provisions in its bid, without an express authorization from the State in the Solicitation to do so, may result in bid disqualification.
7. **EMERGENCY PURCHASES:** The Purchasing Division Director may authorize the Agency to purchase goods or services in the open market that Vendor would otherwise provide under this Contract if those goods or services are for immediate or expedited delivery in an emergency. Emergencies shall include, but are not limited to, delays in transportation or an unanticipated increase in the volume of work. An emergency purchase in the open market, approved by the Purchasing Division Director, shall not constitute a breach of this Contract and shall not entitle the Vendor to any form of compensation or damages. This provision does not excuse the State from fulfilling its obligations under a One Time Purchase contract.
8. **REQUIRED DOCUMENTS:** All of the items checked below must be provided to the Purchasing Division by the Vendor as specified below.
- BID BOND:** All Vendors shall furnish a bid bond in the amount of five percent (5%) of the total amount of the bid protecting the State of West Virginia. The bid bond must be submitted with the bid.

[] **PERFORMANCE BOND:** The apparent successful Vendor shall provide a performance bond in the amount of []. The performance bond must be issued and received by the Purchasing Division prior to Contract award. On construction contracts, the performance bond must be 100% of the Contract value.

[] **LABOR/MATERIAL PAYMENT BOND:** The apparent successful Vendor shall provide a labor/material payment bond in the amount of 100% of the Contract value. The labor/material payment bond must be issued and delivered to the Purchasing Division prior to Contract award.

In lieu of the Bid Bond, Performance Bond, and Labor/Material Payment Bond, the Vendor may provide certified checks, cashier's checks, or irrevocable letters of credit. Any certified check, cashier's check, or irrevocable letter of credit provided in lieu of a bond must be of the same amount and delivered on the same schedule as the bond it replaces. A letter of credit submitted in lieu of a performance and labor/material payment bond will only be allowed for projects under \$100,000. Personal or business checks are not acceptable.

[] **MAINTENANCE BOND:** The apparent successful Vendor shall provide a two (2) year maintenance bond covering the roofing system. The maintenance bond must be issued and delivered to the Purchasing Division prior to Contract award.

[] **WORKERS' COMPENSATION INSURANCE:** The apparent successful Vendor shall have appropriate workers' compensation insurance and shall provide proof thereof upon request.

[] **INSURANCE:** The apparent successful Vendor shall furnish proof of the following insurance prior to Contract award:

[] **Commercial General Liability Insurance:**
[] or more.

[] **Builders Risk Insurance:** builders risk – all risk insurance in an amount equal to 100% of the amount of the Contract.

[] []

[] []

[] []

[] []

[] []

The apparent successful Vendor shall also furnish proof of any additional insurance requirements contained in the specifications prior to Contract award regardless of whether or not that insurance requirement is listed above.

LICENSE(S) / CERTIFICATIONS / PERMITS: In addition to anything required under the Section entitled Licensing, of the General Terms and Conditions, the apparent successful Vendor shall furnish proof of the following licenses, certifications, and/or permits prior to Contract award, in a form acceptable to the Purchasing Division.

<input type="checkbox"/>	
<input type="checkbox"/>	
<input type="checkbox"/>	
<input type="checkbox"/>	

The apparent successful Vendor shall also furnish proof of any additional licenses or certifications contained in the specifications prior to Contract award regardless of whether or not that requirement is listed above.

9. LITIGATION BOND: The Director reserves the right to require any Vendor that files a protest of an award to submit a litigation bond in the amount equal to one percent of the lowest bid submitted or \$5,000, whichever is greater. The entire amount of the bond shall be forfeited if the hearing officer determines that the protest was filed for frivolous or improper purpose, including but not limited to, the purpose of harassing, causing unnecessary delay, or needless expense for the Agency. All litigation bonds shall be made payable to the Purchasing Division. In lieu of a bond, the protester may submit a cashier's check or certified check payable to the Purchasing Division. Cashier's or certified checks will be deposited with and held by the State Treasurer's office. If it is determined that the protest has not been filed for frivolous or improper purpose, the bond or deposit shall be returned in its entirety.

10. ALTERNATES: Any model, brand, or specification listed herein establishes the acceptable level of quality only and is not intended to reflect a preference for, or in any way favor, a particular brand or vendor. Vendors may bid alternates to a listed model or brand provided that the alternate is at least equal to the model or brand and complies with the required specifications. The equality of any alternate being bid shall be determined by the State at its sole discretion. Any Vendor bidding an alternate model or brand should clearly identify the alternate items in its bid and should include manufacturer's specifications, industry literature, and/or any other relevant documentation demonstrating the equality of the alternate items. Failure to provide information for alternate items may be grounds for rejection of a Vendor's bid.

11. EXCEPTIONS AND CLARIFICATIONS: The Solicitation contains the specifications that shall form the basis of a contractual agreement. Vendor shall clearly mark any exceptions, clarifications, or

other proposed modifications in its bid. Exceptions to, clarifications of, or modifications of a requirement or term and condition of the Solicitation may result in bid disqualification.

12. LIQUIDATED DAMAGES: Vendor shall pay liquidated damages in the amount

n/a	for	n/a

This clause shall in no way be considered exclusive and shall not limit the State or Agency's right to pursue any other available remedy.

- 13. ACCEPTANCE/REJECTION:** The State may accept or reject any bid in whole, or in part. Vendor's signature on its bid signifies acceptance of the terms and conditions contained in the Solicitation and Vendor agrees to be bound by the terms of the Contract, as reflected in the Purchase Order, upon receipt.
- 14. REGISTRATION:** Prior to Contract award, the apparent successful Vendor must be properly registered with the West Virginia Purchasing Division and must have paid the \$125 fee if applicable.
- 15. COMMUNICATION LIMITATIONS:** In accordance with West Virginia Code of State Rules §148-1-6.6, communication with the State of West Virginia or any of its employees regarding this Solicitation during the solicitation, bid, evaluation or award periods, except through the Purchasing Division, is strictly prohibited without prior Purchasing Division approval. Purchasing Division approval for such communication is implied for all agency delegated and exempt purchases.
- 16. FUNDING:** This Contract shall continue for the term stated herein, contingent upon funds being appropriated by the Legislature or otherwise being made available. In the event funds are not appropriated or otherwise made available, this Contract becomes void and of no effect beginning on July 1 of the fiscal year for which funding has not been appropriated or otherwise made available.
- 17. PAYMENT:** Payment in advance is prohibited under this Contract. Payment may only be made after the delivery and acceptance of goods or services. The Vendor shall submit invoices, in arrears, to the Agency at the address on the face of the purchase order labeled "Invoice To."
- 18. UNIT PRICE:** Unit prices shall prevail in cases of a discrepancy in the Vendor's bid.
- 19. DELIVERY:** All quotations are considered freight on board destination ("F.O.B. destination") unless alternate shipping terms are clearly identified in the bid. Vendor's listing of shipping terms that contradict the shipping terms expressly required by this Solicitation may result in bid disqualification.
- 20. INTEREST:** Interest attributable to late payment will only be permitted if authorized by the West Virginia Code. Presently, there is no provision in the law for interest on late payments.
- 21. PREFERENCE:** Vendor Preference may only be granted upon written request and only in accordance with the West Virginia Code § 5A-3-37 and the West Virginia Code of State Rules. A Resident Vendor Certification form has been attached hereto to allow Vendor to apply for the preference. Vendor's

failure to submit the Resident Vendor Certification form with its bid will result in denial of Vendor Preference. Vendor Preference does not apply to construction projects.

- 22. SMALL, WOMEN-OWNED, OR MINORITY-OWNED BUSINESSES:** For any solicitations publicly advertised for bid on or after July 1, 2012, in accordance with West Virginia Code §5A-3-37(a)(7) and W. Va. CSR § 148-22-9, any non-resident vendor certified as a small, women-owned, or minority-owned business under W. Va. CSR § 148-22-9 shall be provided the same preference made available to any resident vendor. Any non-resident small, women-owned, or minority-owned business must identify itself as such in writing, must submit that writing to the Purchasing Division with its bid, and must be properly certified under W. Va. CSR § 148-22-9 prior to submission of its bid to receive the preferences made available to resident vendors. Preference for a non-resident small, women-owned, or minority owned business shall be applied in accordance with W. Va. CSR § 148-22-9.
- 23. TAXES:** The Vendor shall pay any applicable sales, use, personal property or any other taxes arising out of this Contract and the transactions contemplated thereby. The State of West Virginia is exempt from federal and state taxes and will not pay or reimburse such taxes.
- 24. CANCELLATION:** The Purchasing Division Director reserves the right to cancel this Contract immediately upon written notice to the vendor if the materials or workmanship supplied do not conform to the specifications contained in the Contract. The Purchasing Division Director may cancel any purchase or Contract upon 30 days written notice to the Vendor in accordance with West Virginia Code of State Rules § 148-1-7.16.2.
- 25. WAIVER OF MINOR IRREGULARITIES:** The Director reserves the right to waive minor irregularities in bids or specifications in accordance with West Virginia Code of State Rules § 148-1-4.6.
- 26. TIME:** Time is of the essence with regard to all matters of time and performance in this Contract.
- 27. APPLICABLE LAW:** This Contract is governed by and interpreted under West Virginia law without giving effect to its choice of law principles. Any information provided in specification manuals, or any other source, verbal or written, which contradicts or violates the West Virginia Constitution, West Virginia Code or West Virginia Code of State Rules is void and of no effect.
- 28. COMPLIANCE:** Vendor shall comply with all applicable federal, state, and local laws, regulations and ordinances. By submitting a bid, Vendors acknowledge that they have reviewed, understand, and will comply with all applicable law.
- 29. PREVAILING WAGE:** On any contract for the construction of a public improvement, Vendor and any subcontractors utilized by Vendor shall pay a rate or rates of wages which shall not be less than the fair minimum rate or rates of wages (prevailing wage), as established by the West Virginia Division of Labor under West Virginia Code §§ 21-5A-1 et seq. and available at <http://www.sos.wv.gov/administrative-law/wagerates/Pages/default.aspx>. Vendor shall be responsible for ensuring compliance with prevailing wage requirements and determining when prevailing wage

requirements are applicable. The required contract provisions contained in West Virginia Code of State Rules § 42-7-3 are specifically incorporated herein by reference.

- 30. ARBITRATION:** Any references made to arbitration contained in this Contract, Vendor's bid, or in any American Institute of Architects documents pertaining to this Contract are hereby deleted, void, and of no effect.
- 31. MODIFICATIONS:** This writing is the parties' final expression of intent. Notwithstanding anything contained in this Contract to the contrary, no modification of this Contract shall be binding without mutual written consent of the Agency, and the Vendor, with approval of the Purchasing Division and the Attorney General's office (Attorney General approval is as to form only). **No Change shall be implemented by the Vendor until such time as the Vendor receives an approved written change order from the Purchasing Division.**
- 32. WAIVER:** The failure of either party to insist upon a strict performance of any of the terms or provision of this Contract, or to exercise any option, right, or remedy herein contained, shall not be construed as a waiver or a relinquishment for the future of such term, provision, option, right, or remedy, but the same shall continue in full force and effect. Any waiver must be expressly stated in writing and signed by the waiving party.
- 33. SUBSEQUENT FORMS:** The terms and conditions contained in this Contract shall supersede any and all subsequent terms and conditions which may appear on any form documents submitted by Vendor to the Agency or Purchasing Division such as price lists, order forms, invoices, sales agreements, or maintenance agreements, and includes internet websites or other electronic documents. Acceptance or use of Vendor's forms does not constitute acceptance of the terms and conditions contained thereon.
- 34. ASSIGNMENT:** Neither this Contract nor any monies due, or to become due hereunder, may be assigned by the Vendor without the express written consent of the Agency, the Purchasing Division, the Attorney General's office (as to form only), and any other government agency or office that may be required to approve such assignments. Notwithstanding the foregoing, Purchasing Division approval may or may not be required on certain agency delegated or exempt purchases.
- 35. WARRANTY:** The Vendor expressly warrants that the goods and/or services covered by this Contract will: (a) conform to the specifications, drawings, samples, or other description furnished or specified by the Agency; (b) be merchantable and fit for the purpose intended; and (c) be free from defect in material and workmanship.
- 36. STATE EMPLOYEES:** State employees are not permitted to utilize this Contract for personal use and the Vendor is prohibited from permitting or facilitating the same.
- 37. BANKRUPTCY:** In the event the Vendor files for bankruptcy protection, the State of West Virginia may deem this Contract null and void, and terminate this Contract without notice.

- 38. HIPAA BUSINESS ASSOCIATE ADDENDUM:** The West Virginia State Government HIPAA Business Associate Addendum (BAA), approved by the Attorney General, is available online at <http://www.state.wv.us/admin/purchase/vrc/hipaa.html> and is hereby made part of the agreement provided that the Agency meets the definition of a Covered entity (45 CFR §160.103) and will be disclosing Protected Health Information (45 CFR §160.103) to the Vendor. Additionally, the HIPAA Privacy, Security, Enforcement & Breach Notification Final Omnibus Rule was published on January 25, 2013. It may be viewed online at <http://www.gpo.gov/fdsys/pkg/FR-2013-01-25/pdf/2013-01073.pdf>. Any organization, that qualifies as the Agency's Business Associate, is expected to be in compliance with this Final Rule. For those Business Associates entering into contracts with a HIPAA Covered State Agency between January 25, 2013 and the release of the 2013 WV State Agency Business Associate Agreement, or September 23, 2013 (whichever is earlier), be advised that you will be required to comply with the 2013 WV State Agency Business Associate Agreement. For those Business Associates with contracts with a HIPAA Covered State Agency executed prior to January 25, 2013, be advised that upon renewal or modification, you will be required to comply with the 2013 WV State Agency Business Associate Agreement no later than September 22, 2014.
- 39. CONFIDENTIALITY:** The Vendor agrees that it will not disclose to anyone, directly or indirectly, any such personally identifiable information or other confidential information gained from the Agency, unless the individual who is the subject of the information consents to the disclosure in writing or the disclosure is made pursuant to the Agency's policies, procedures, and rules. Vendor further agrees to comply with the Confidentiality Policies and Information Security Accountability Requirements, set forth in <http://www.state.wv.us/admin/purchase/privacy/default.html>.
- 40. DISCLOSURE:** Vendor's response to the Solicitation and the resulting Contract are considered public documents and will be disclosed to the public in accordance with the laws, rules, and policies governing the West Virginia Purchasing Division. Those laws include, but are not limited to, the Freedom of Information Act found in West Virginia Code § 29B-1-1 et seq.

If a Vendor considers any part of its bid to be exempt from public disclosure, Vendor must so indicate by specifically identifying the exempt information, identifying the exemption that applies, providing a detailed justification for the exemption, segregating the exempt information from the general bid information, and submitting the exempt information as part of its bid but in a segregated and clearly identifiable format. Failure to comply with the foregoing requirements will result in public disclosure of the Vendor's bid without further notice. A Vendor's act of marking all or nearly all of its bid as exempt is not sufficient to avoid disclosure and WILL NOT BE HONORED. Vendor's act of marking a bid or any part thereof as "confidential" or "proprietary" is not sufficient to avoid disclosure and WILL NOT BE HONORED. In addition, a legend or other statement indicating that all or substantially all of the bid is exempt from disclosure is not sufficient to avoid disclosure and WILL NOT BE HONORED. Vendor will be required to defend any claimed exemption for nondisclosure in the event of an administrative or judicial challenge to the State's nondisclosure. Vendor must indemnify the State for any costs incurred related to any exemptions claimed by Vendor. Any questions regarding the applicability of the various public records laws should be addressed to your own legal counsel prior to bid submission.

41. **LICENSING:** In accordance with West Virginia Code of State Rules §148-1-6.1.7, Vendor must be licensed and in good standing in accordance with any and all state and local laws and requirements by any state or local agency of West Virginia, including, but not limited to, the West Virginia Secretary of State's Office, the West Virginia Tax Department, West Virginia Insurance Commission, or any other state agency or political subdivision. Upon request, the Vendor must provide all necessary releases to obtain information to enable the Purchasing Division Director or the Agency to verify that the Vendor is licensed and in good standing with the above entities.
42. **ANTITRUST:** In submitting a bid to, signing a contract with, or accepting a Purchase Order from any agency of the State of West Virginia, the Vendor agrees to convey, sell, assign, or transfer to the State of West Virginia all rights, title, and interest in and to all causes of action it may now or hereafter acquire under the antitrust laws of the United States and the State of West Virginia for price fixing and/or unreasonable restraints of trade relating to the particular commodities or services purchased or acquired by the State of West Virginia. Such assignment shall be made and become effective at the time the purchasing agency tenders the initial payment to Vendor.
43. **VENDOR CERTIFICATIONS:** By signing its bid or entering into this Contract, Vendor certifies (1) that its bid was made without prior understanding, agreement, or connection with any corporation, firm, limited liability company, partnership, person or entity submitting a bid for the same material, supplies, equipment or services; (2) that its bid is in all respects fair and without collusion or fraud; (3) that this Contract is accepted or entered into without any prior understanding, agreement, or connection to any other entity that could be considered a violation of law; and (4) that it has reviewed this RFQ in its entirety; understands the requirements, terms and conditions, and other information contained herein. Vendor's signature on its bid also affirms that neither it nor its representatives have any interest, nor shall acquire any interest, direct or indirect, which would compromise the performance of its services hereunder. Any such interests shall be promptly presented in detail to the Agency.

The individual signing this bid on behalf of Vendor certifies that he or she is authorized by the Vendor to execute this bid or any documents related thereto on Vendor's behalf; that he or she is authorized to bind the Vendor in a contractual relationship; and that, to the best of his or her knowledge, the Vendor has properly registered with any State agency that may require registration.

44. **PURCHASING CARD ACCEPTANCE:** The State of West Virginia currently utilizes a Purchasing Card program, administered under contract by a banking institution, to process payment for goods and services. The Vendor must accept the State of West Virginia's Purchasing Card for payment of all orders under this Contract unless the box below is checked.

Vendor is not required to accept the State of West Virginia's Purchasing Card as payment for all goods and services.

45. **VENDOR RELATIONSHIP:** The relationship of the Vendor to the State shall be that of an independent contractor and no principal-agent relationship or employer-employee relationship is contemplated or created by this Contract. The Vendor as an independent contractor is solely liable for the acts and omissions of its employees and agents. Vendor shall be responsible for selecting,

supervising, and compensating any and all individuals employed pursuant to the terms of this Solicitation and resulting contract. Neither the Vendor, nor any employees or subcontractors of the Vendor, shall be deemed to be employees of the State for any purpose whatsoever. Vendor shall be exclusively responsible for payment of employees and contractors for all wages and salaries, taxes, withholding payments, penalties, fees, fringe benefits, professional liability insurance premiums, contributions to insurance and pension, or other deferred compensation plans, including but not limited to, Workers' Compensation and Social Security obligations, licensing fees, *etc.* and the filing of all necessary documents, forms and returns pertinent to all of the foregoing. Vendor shall hold harmless the State, and shall provide the State and Agency with a defense against any and all claims including, but not limited to, the foregoing payments, withholdings, contributions, taxes, Social Security taxes, and employer income tax returns.

46. **INDEMNIFICATION:** The Vendor agrees to indemnify, defend, and hold harmless the State and the Agency, their officers, and employees from and against: (1) Any claims or losses for services rendered by any subcontractor, person, or firm performing or supplying services, materials, or supplies in connection with the performance of the Contract; (2) Any claims or losses resulting to any person or entity injured or damaged by the Vendor, its officers, employees, or subcontractors by the publication, translation, reproduction, delivery, performance, use, or disposition of any data used under the Contract in a manner not authorized by the Contract, or by Federal or State statutes or regulations; and (3) Any failure of the Vendor, its officers, employees, or subcontractors to observe State and Federal laws including, but not limited to, labor and wage and hour laws.
47. **PURCHASING AFFIDAVIT:** In accordance with West Virginia Code § 5A-3-10a, all Vendors are required to sign, notarize, and submit the Purchasing Affidavit stating that neither the Vendor nor a related party owe a debt to the State in excess of \$1,000. The affidavit must be submitted prior to award, but should be submitted with the Vendor's bid. A copy of the Purchasing Affidavit is included herewith.
48. **ADDITIONAL AGENCY AND LOCAL GOVERNMENT USE:** This Contract may be utilized by and extends to other agencies, spending units, and political subdivisions of the State of West Virginia; county, municipal, and other local government bodies; and school districts ("Other Government Entities"). This Contract shall be extended to the aforementioned Other Government Entities on the same prices, terms, and conditions as those offered and agreed to in this Contract. If the Vendor does not wish to extend the prices, terms, and conditions of its bid and subsequent contract to the Other Government Entities, the Vendor must clearly indicate such refusal in its bid. A refusal to extend this Contract to the Other Government Entities shall not impact or influence the award of this Contract in any manner.
49. **CONFLICT OF INTEREST:** Vendor, its officers or members or employees, shall not presently have or acquire any interest, direct or indirect, which would conflict with or compromise the performance of its obligations hereunder. Vendor shall periodically inquire of its officers, members and employees to ensure that a conflict of interest does not arise. Any conflict of interest discovered shall be promptly presented in detail to the Agency.

50. REPORTS: Vendor shall provide the Agency and/or the Purchasing Division with the following reports identified by a checked box below:

- Such reports as the Agency and/or the Purchasing Division may request. Requested reports may include, but are not limited to, quantities purchased, agencies utilizing the contract, total contract expenditures by agency, etc.
- Quarterly reports detailing the total quantity of purchases in units and dollars, along with a listing of purchases by agency. Quarterly reports should be delivered to the Purchasing Division via email at purchasing.requisitions@wv.gov.

51. BACKGROUND CHECK: In accordance with W. Va. Code § 15-2D-3, the Director of the Division of Protective Services shall require any service provider whose employees are regularly employed on the grounds or in the buildings of the Capitol complex or who have access to sensitive or critical information to submit to a fingerprint-based state and federal background inquiry through the state repository. The service provider is responsible for any costs associated with the fingerprint-based state and federal background inquiry.

After the contract for such services has been approved, but before any such employees are permitted to be on the grounds or in the buildings of the Capitol complex or have access to sensitive or critical information, the service provider shall submit a list of all persons who will be physically present and working at the Capitol complex to the Director of the Division of Protective Services for purposes of verifying compliance with this provision.

The State reserves the right to prohibit a service provider's employees from accessing sensitive or critical information or to be present at the Capitol complex based upon results addressed from a criminal background check.

Service providers should contact the West Virginia Division of Protective Services by phone at (304) 558-9911 for more information.

52. PREFERENCE FOR USE OF DOMESTIC STEEL PRODUCTS: Except when authorized by the Director of the Purchasing Division pursuant to W. Va. Code § 5A-3-56, no contractor may use or supply steel products for a State Contract Project other than those steel products made in the United States. A contractor who uses steel products in violation of this section may be subject to civil penalties pursuant to W. Va. Code § 5A-3-56. As used in this section:

- a. "State Contract Project" means any erection or construction of, or any addition to, alteration of or other improvement to any building or structure, including, but not limited to, roads or highways, or the installation of any heating or cooling or ventilating plants or other equipment, or the supply of and materials for such projects, pursuant to a contract with the State of West Virginia for which bids were solicited on or after June 6, 2001.
- b. "Steel Products" means products rolled, formed, shaped, drawn, extruded, forged, cast, fabricated or otherwise similarly processed, or processed by a combination of two or more or

such operations, from steel made by the open hearth, basic oxygen, electric furnace, Bessemer or other steel making process.

The Purchasing Division Director may, in writing, authorize the use of foreign steel products if:

- a. The cost for each contract item used does not exceed one tenth of one percent (.1%) of the total contract cost or two thousand five hundred dollars (\$2,500.00), whichever is greater. For the purposes of this section, the cost is the value of the steel product as delivered to the project; or
- b. The Director of the Purchasing Division determines that specified steel materials are not produced in the United States in sufficient quantity or otherwise are not reasonably available to meet contract requirements.

53. PREFERENCE FOR USE OF DOMESTIC ALUMINUM, GLASS, AND STEEL: In Accordance with W. Va. Code § 5-19-1 et seq., and W. Va. CSR § 148-10-1 et seq., for every contract or subcontract, subject to the limitations contained herein, for the construction, reconstruction, alteration, repair, improvement or maintenance of public works or for the purchase of any item of machinery or equipment to be used at sites of public works, only domestic aluminum, glass or steel products shall be supplied unless the spending officer determines, in writing, after the receipt of offers or bids, (1) that the cost of domestic aluminum, glass or steel products is unreasonable or inconsistent with the public interest of the State of West Virginia, (2) that domestic aluminum, glass or steel products are not produced in sufficient quantities to meet the contract requirements, or (3) the available domestic aluminum, glass, or steel do not meet the contract specifications. This provision only applies to public works contracts awarded in an amount more than fifty thousand dollars (\$50,000) or public works contracts that require more than ten thousand pounds of steel products.

The cost of domestic aluminum, glass, or steel products may be unreasonable if the cost is more than twenty percent (20%) of the bid or offered price for foreign made aluminum, glass, or steel products. If the domestic aluminum, glass or steel products to be supplied or produced in a "substantial labor surplus area", as defined by the United States Department of Labor, the cost of domestic aluminum, glass, or steel products may be unreasonable if the cost is more than thirty percent (30%) of the bid or offered price for foreign made aluminum, glass, or steel products.

This preference shall be applied to an item of machinery or equipment, as indicated above, when the item is a single unit of equipment or machinery manufactured primarily of aluminum, glass or steel, is part of a public works contract and has the sole purpose or of being a permanent part of a single public works project. This provision does not apply to equipment or machinery purchased by a spending unit for use by that spending unit and not as part of a single public works project.

All bids and offers including domestic aluminum, glass or steel products that exceed bid or offer prices including foreign aluminum, glass or steel products after application of the preferences provided in this provision may be reduced to a price equal to or lower than the lowest bid or offer price for foreign aluminum, glass or steel products plus the applicable preference. If the reduced bid or offer prices are made in writing and supersede the prior bid or offer prices, all bids or offers, including the reduced bid or offer prices, will be reevaluated in accordance with this rule.

ADDITIONAL TERMS AND CONDITIONS (Construction Contracts Only)

1. **CONTRACTOR'S LICENSE:** West Virginia Code § 21-11-2 requires that all persons desiring to perform contracting work in this state be licensed. The West Virginia Contractors Licensing Board is empowered to issue the contractor's license. Applications for a contractor's license may be made by contacting the West Virginia Division of Labor.

West Virginia Code § 21-11-11 requires any prospective Vendor to include the contractor's license number on its bid. Failure to include a contractor's license number on the bid shall result in Vendor's bid being disqualified. Vendors should include a contractor's license number in the space provided below.

Contractor's Name: Safety Caution Equipment Company

Contractor's License No. WV032155

The apparent successful Vendor must furnish a copy of its contractor's license prior to the issuance of a purchase order/contract.

2. **DRUG-FREE WORKPLACE:** W. Va. Code § 21-1D-5 provides that any solicitation for a public improvement contract requires each Vendor that submits a bid for the work to submit at the same time an affidavit that the Vendor has a written plan for a drug-free workplace policy. To comply with this law, Vendor must either complete the enclosed drug-free workplace affidavit and submit the same with its bid or complete a similar affidavit that fulfills all of the requirements of the applicable code. Failure to submit the signed and notarized drug-free workplace affidavit, or a similar affidavit that fully complies with the requirements of the applicable code, with the bid shall result in disqualification of Vendor's bid.
3. **AIA DOCUMENTS:** All construction contracts that will be completed in conjunction with architectural services procured under Chapter 5G of the West Virginia Code will be governed by the AIA A101-2007 and A201-2007 or the A107-2007 documents, as amended by the Supplementary Conditions for the State of West Virginia, in addition to the terms and conditions contained herein.
4. **SUBCONTRACTOR LIST SUBMISSION:** In accordance with W. Va. Code § 5-22-1, The apparent low bidder on a contract for the construction, alteration, decoration, painting or improvement of a new or existing building or structure valued at more than \$500,000.00 shall submit a list of all subcontractors who will perform more than \$25,000.00 of work on the project including labor and materials. This provision shall not apply to any other construction projects, such as highway, mine reclamation, water or sewer projects.

- c. **Required Information.** The subcontractor list shall contain the following information:
 - i. Bidder's name
 - ii. Name of each subcontractor
 - iii. License numbers as required by W. Va. Code § 21-11-1 et. seq.
 - iv. Notation that no subcontractors will be used if the bidder will perform the work

 - d. **Submission.** The completed subcontractor list shall be provided to the Purchasing Division within one business day of the opening of bids for review. Failure to submit the subcontractor list within one business day after the deadline for submitting bids shall result in disqualification of the bid.

 - e. **Substitution of Subcontractor.** Written approval must be obtained from the Purchasing Division before any subcontractor substitution is permitted. Substitutions are not permitted unless:
 - i. The subcontractor listed in the original bid has filed for bankruptcy;
 - ii. The subcontractor in the original bid has been debarred or suspended; or
 - iii. The contractor certifies in writing that the subcontractor listed in the original bill fails, is unable, or refuses to perform his subcontract.
5. **GREEN BUILDINGS MINIMUM ENERGY STANDARDS:** In accordance with § 22-29-4, all new building construction projects of public agencies that have not entered the schematic design phase prior to July 1, 2012, or any building construction project receiving state grant funds and appropriations, including public schools, that have not entered the schematic design phase prior to July 1, 2012, shall be designed and constructed complying with the ICC International Energy Conservation Code, adopted by the State Fire Commission, and the ANSI/ASHRAE/IESNA Standard 90.1-2007: *Provided*, That if any construction project has a commitment of federal funds to pay for a portion of such project, this provision shall only apply to the extent such standards are consistent with the federal standards.

ADDITIONAL TERMS AND CONDITIONS (Architectural and Engineering Contracts Only)

1. **PLAN AND DRAWING DISTRIBUTION:** All plans and drawings must be completed and available for distribution at least five business days prior to a scheduled pre-bid meeting for the construction or other work related to the plans and drawings.
2. **PROJECT ADDENDA REQUIREMENTS:** The Architect/Engineer and/or Agency shall be required to abide by the following schedule in issuing construction project addenda:
 - a. The Architect/Engineer shall prepare any addendum materials for which it is responsible, and a list of all vendors that have obtained drawings and specifications for the project. The Architect/Engineer shall then send a copy of the addendum materials and the list of vendors to the State Agency for which the contract is issued to allow the Agency to make any necessary modifications. The addendum and list shall then be forwarded to the Purchasing Division buyer by the Agency. The Purchasing Division buyer shall send the addendum to all interested vendors and, if necessary, extend the bid opening date. Any addendum should be received by the Purchasing Division at least fourteen (14) days prior to the bid opening date.
3. **PRE-BID MEETING RESPONSIBILITIES:** The Architect/Engineer shall be available to attend any pre-bid meeting for the construction or other work resulting from the plans, drawings, or specifications prepared by the Architect/Engineer.
4. **AIA DOCUMENTS:** Contracts for architectural and engineering services will be governed by the AIA document B101-2007, as amended by the Supplementary Conditions for the State of West Virginia, in addition to the terms and conditions contained herein when procured under Chapter 5G of the West Virginia Code.
5. **GREEN BUILDINGS MINIMUM ENERGY STANDARDS:** In accordance with West Virginia Code § 22-29-4, all new building construction projects of public agencies that have not entered the schematic design phase prior to July 1, 2012, or any building construction project receiving state grant funds and appropriations, including public schools, that have not entered the schematic design phase prior to July 1, 2012, shall be designed and constructed complying with the ICC International Energy Conservation Code, adopted by the State Fire Commission, and the ANSI/ASHRAE/IESNA Standard 90.1-2007; *Provided*, That if any construction project has a commitment of federal funds to pay for a portion of such project, this provision shall only apply to the extent such standards are consistent with the federal standards.

CERTIFICATION AND SIGNATURE PAGE

By signing below, I certify that I have reviewed this Solicitation in its entirety; understand the requirements, terms and conditions, and other information contained herein; that I am submitting this bid or proposal for review and consideration; that I am authorized by the bidder to execute this bid or any documents related thereto on bidder's behalf; that I am authorized to bind the bidder in a contractual relationship; and that to the best of my knowledge, the bidder has properly registered with any State agency that may require registration.

Safety Caution Equipment Company
(Company)

Sara Matheney
(Authorized Signature)

Sara Matheney, President
(Representative Name, Title)

304-346-5521 304-346-5554
(Phone Number) (Fax Number)

June 12, 2013
(Date)

ADDENDUM ACKNOWLEDGEMENT FORM
SOLICITATION NO.: 7013EC02

Instructions: Please acknowledge receipt of all addenda issued with this solicitation by completing this addendum acknowledgment form. Check the box next to each addendum received and sign below. Failure to acknowledge addenda may result in bid disqualification.

Acknowledgment: I hereby acknowledge receipt of the following addenda and have made the necessary revisions to my proposal, plans and/or specification, etc.

Addendum Numbers Received:

(Check the box next to each addendum received)

- | | |
|--|--|
| <input checked="" type="checkbox"/> Addendum No. 1 | <input type="checkbox"/> Addendum No. 6 |
| <input checked="" type="checkbox"/> Addendum No. 2 | <input type="checkbox"/> Addendum No. 7 |
| <input type="checkbox"/> Addendum No. 3 | <input type="checkbox"/> Addendum No. 8 |
| <input type="checkbox"/> Addendum No. 4 | <input type="checkbox"/> Addendum No. 9 |
| <input type="checkbox"/> Addendum No. 5 | <input type="checkbox"/> Addendum No. 10 |

I understand that failure to confirm the receipt of addenda may be cause for rejection of this bid. I further understand that any verbal representation made or assumed to be made during any oral discussion held between Vendor's representatives and any state personnel is not binding. Only the information issued in writing and added to the specifications by an official addendum is binding.

Safety Caution Equipment Company

Company

Sara Mathoney

 Authorized Signature

June 12, 2013

Date

NOTE: This addendum acknowledgment should be submitted with the bid to expedite document processing.

REQUEST FOR QUOTATION
RFQ 7013EC02 843 CLASS FULL MATRIX TRAILER MOUNTED
SOLAR POWERED MESSAGE BOARD

SPECIFICATIONS

1. **PURPOSE AND SCOPE:** The West Virginia Purchasing Division is soliciting bids On behalf of the West Virginia Division of Highways, Department of Transportation to establish an open-end contract for Full Matrix Trailer Mounted Solar Powered Message Board.

2. **DEFINITIONS:** The terms listed below shall have the meanings assigned to them below. Additional definitions can be found in section 2 of the General Terms and Conditions.
 - 2.1 “Contract Item” or “Contract Items” means the list of items identified in Section 3, Subsection 1 below.
 - 2.2 “Pricing Pages” means the schedule of prices, estimated order quantity, and totals attached hereto as Exhibit A and used to evaluate the RFQ.
 - 2.3 “RFQ” means the official request for quotation published by the Purchasing Division and identified as 7013EC02.
 - 2.4 “NTPEP” means National Transportation Product Evaluation Program.
 - 2.5 “MUTCD” means Manual Uniform Traffic Control Devices.
 - 2.6 “PVMS” means Portable Variable Message Signs.
 - 2.7 “NTCIP” means National Transportation Communication For Its Protocol.

3. **GENERAL REQUIREMENTS:**
 - 3.1 **Contract Items and Mandatory Requirements:** Vendor shall provide Agency with the Contract Items listed below on an open-end and continuing basis. Contract Items must meet or exceed the mandatory requirements as shown below.
 - 3.1.1 **Full – Matrix Trailer Mounted Solar Powered Message Board**
 - 3.1.1.1 **General – The Full – Matrix Trailer Mounted Solar Powered Message Board must:**
 - 3.1.1.1.1 Be tested by AASHTO’s National Transportation Product Evaluation Program (NTPEP)

REQUEST FOR QUOTATION
RFQ 7013EC02 843 CLASS FULL MATRIX TRAILER MOUNTED
SOLAR POWERED MESSAGE BOARD

3.1.1.1.2 Certify that unit offered will comply with Occupational Safety and Health Act of 1970 and subsequent amendments.

3.1.1.2 Sign Face – The following are mandatory requirements related to the sign face.

- 3.1.1.2.1 The sign face shall be of a sufficient size in order to display three (3) lines of eight (8) characters, each character must be minimum eighteen (18) inches tall by minimum twelve (12) inches wide. Characters must be spaced a minimum of three (3) inches apart.
- 3.1.1.2.2 The face of sign shall incorporate measures to prevent fading from UV light, such as a polycarbonate or lexan face with UV inhibitors incorporated.
- 3.1.1.2.3 Optically enhanced L.E.D.s shall have a minimum of 30° vertical and 30° horizontal cone of visibility.
- 3.1.1.2.4 Each pixel shall consist of a minimum of three (3) L.E.D.s.
- 3.1.1.2.5 Message color shall be a minimum 590 nanometers.
- 3.1.1.2.6 The sign shall have the capability to display up to six (6) messages in sequence, with variable timing in ¼ second increments under computer control.
- 3.1.1.2.7 As part of the manufacturer's pre-programmed message sequences, arrow display and flashing caution functions shall be included. All arrow and flashing caution displays described in the current MUTCD shall be provided.
- 3.1.1.2.8 All abbreviations used in pre-programmed messages shall be in compliance with the current MUTCD.
- 3.1.1.2.9 The sign shall be clearly visible a minimum of 4500 feet.
- 3.1.1.2.10 The sign legend shall be legible from a minimum distance of 1,000 feet under daylight conditions as defined by NTPEP for two- non-traffic word messages.

REQUEST FOR QUOTATION
RFQ 7013EC02 843 CLASS FULL MATRIX TRAILER MOUNTED
SOLAR POWERED MESSAGE BOARD

3.1.1.2.11 The sign legend shall be legible from a minimum distance of 900 feet under night-time conditions as by NTPEP for a two-non-traffic word message.

3.1.1.2.12 Under variable light conditions, the unit shall automatically adjust light source so as to meet the visibility requirements, without being too bright or too dim.

3.1.1.2.13 Entire sign shall have the capability to change all lines of message copy in not more than 100 mili-seconds.

3.1.1.2.14 Each character configuration shall contain 54 L.E.D. lamp pixels in a six (6) element horizontal by nine (9) element vertical arrangement.

3.1.1.3 Sign Panel-The following are mandatory requirements related to the solar message board sign panel.

3.1.1.3.1 Length of sign panel shall not exceed 140 inches.

3.1.1.3.2 All exposed panels and seams shall be corrosion proof for a minimum of ten (10) years. With construction, all panels/parts shall be assembled as to prevent corrosion or to prevent dissimilar metal reaction from occurring.

3.1.1.3.3 The panel shall be supported on a telescoping upright member in order to permit raising the sign panel for operation and lowering the panel for transport. The upright must be capable of 360 degrees rotation and to lock into any position to which it is manually or electrically rotated.

3.1.1.3.4 Raise and lower travel shall be minimum of four (4) feet and shall be accomplished by a hydraulic power pack.

3.1.1.3.5 The bottom of the sign shall be a minimum of seven (7) feet above ground level when in the raised position.

REQUEST FOR QUOTATION
RFQ 7013EC02 843 CLASS FULL MATRIX TRAILER MOUNTED
SOLAR POWERED MESSAGE BOARD

3.1.1.3.6 In transport position, the sign shall orient to the longitudinal axis of the trailer in a manner that effectively reduces aerodynamic drag during towing.

3.1.1.3.7 The solar panel generator array shall recharge the battery bank at a rate of 2.5 hours sun to one (1) 24 hour period of usage.

3.1.1.4 Power Source – The following are mandatory requirements related to the power source.

3.1.1.4.1 The full-matrix panel shall be powered by a bank of batteries in order to convey bright, distinctive messages to the traveling public.

3.1.1.4.2 Unit shall be designed to accept two (2) power sources: one (1) being a battery bank consisting of four (4) size 4-D, deep cycle, lead acid 12 volt DC batteries wired in parallel.

3.1.1.4.3 Batteries shall be automatically recharged by a group of solar panels producing a minimum 165 watts of power, located at the highest point on the unit.

3.1.1.4.4 Unit shall be designed with sufficient energy backup to operate for a period of 30 days without any sun.

3.1.1.4.5 Unit shall provide a built-in battery charger with a minimum 25 ampere per hour rating.

3.1.1.4.6 Battery bank shall be housed in lockable heavy duty weatherproof battery boxes.

3.1.1.5 Computer – The following are mandatory requirements related to the computer system for the message board.

3.1.1.5.1 The unit shall be controlled in all functions by an on-board dedicated computer of solid state design and be removable.

3.1.1.5.2 Unit shall include a keyboard or graphic touch screen controller through which user originated messages may be entered for display or storage.

REQUEST FOR QUOTATION
RFQ 7013EC02 843 CLASS FULL MATRIX TRAILER MOUNTED
SOLAR POWERED MESSAGE BOARD

27

3.1.1.5.3 Computer shall store a minimum of 250 programmed messages for display when called upon by user through the keyboard.

3.1.1.5.4 Unit shall include an LCD display screen upon which messages can be reviewed before display on sign board.

3.1.1.6 Solar Panel Control Unit – The following are mandatory requirements related to the control unit.

3.1.1.6.1 The power control unit and computer shall be housed in a weather resistant, shock resistant lockable control box which includes lighting for night-time operation.

3.1.1.6.2 Power control unit shall contain two (2) current meters; one (1) to show amperage generated with the battery charge operating, and one (1) to indicate amperage generated from the solar panels to be stored in the battery bank.

3.1.1.6.3 Message Cabinet dimensions shall be:
A. Length: Maximum 140 inches.
B. Height: Maximum 79 ½ inches.

3.1.1.6.4 The power control unit shall incorporate a PV regulator with thermal compensation for variances in ambient temperature to regulate the charge rate to battery bank.

3.1.1.6.5 The unit shall incorporate an automatic intensity control feature in order to keep L.E.D. lamp matrix intensity constant with a reduction in voltage.

3.1.1.6.6 The message unit shall provide a photocell in order to reduce the lamp intensity at night eliminating blinding.

3.1.1.7 Central Processing Unit – The following are mandatory, minimum requirements related to the central processing unit (CPU) specifications:

3.1.1.7.1 Microprocessor Based 27.1 MHz.

3.1.1.7.2 Power requirements: 175 mA DC at 12 volts DC.

REQUEST FOR QUOTATION
RFQ 7013EC02 843 CLASS FULL MATRIX TRAILER MOUNTED
SOLAR POWERED MESSAGE BOARD

- 3.1.1.7.3 Screen size: Minimum of three (3) lines, with Eight (8) characters per line.
- 3.1.1.7.4 Interfaces: (2) RS232 9 pin D connectors and documentation on port numbers and pins. In addition, one USB port or one Ethernet Port with USB adaptor shall be provided.
- 3.1.1.7.5 Code: Application source code shall be delivered with unit.
- 3.1.1.7.6 Documentation: Technical documentation and application programs shall be delivered with unit.

3.1.1.8 Communication- The following are mandatory requirements related to communication.

- 3.1.1.8.1 Unit shall be guarded from any unwanted outside RF interference which would include but not be limited to VHF/FM receiver, 2 way radio receiver, cell phones, etc.
- 3.1.1.8.2 Each PVMS shall be controlled and monitored by its own sign controller directly from the control console inside the control cabinet on the trailer itself.
- 3.1.1.8.3 The PVMS sign controller shall be able to receive instructions from and provide information to a computer containing PVMS control software compliant using NTCIP compliant communications modes.
- 3.1.1.8.4 The system communications backbone, as well as all field modems or signal converters, shall provide the PVMS sign controller with a RS232 signal having a baud rate between 2,400 bps and 115,200 bps. Remote Communications control via wireless communications with a remotely located computer.
- 3.1.1.8.5 Local Communications control shall be available via direct connection with a laptop computer that is connected directly to the sign control using a null modem connection and a baud rate between 2,400 bps and 115,200 bps.

REQUEST FOR QUOTATION
RFQ 7013EC02 843 CLASS FULL MATRIX TRAILER MOUNTED
SOLAR POWERED MESSAGE BOARD

3.1.1.8.6 Local Communications control via a keypad and LCD interface: Features shall include addition or removal of message or message(s) from the PVMS list of playing messages, adjustment of luminosity to manual or automatic, and monitor miscellaneous data like battery voltage, photocells reading, etc.

3.1.1.9 Trailer – The following are mandatory requirements related to the Trailer that will transport the message board.

3.1.1.9.1 Two (2) wheel trailer shall be structurally adequate to serve both platform for components.

3.1.1.9.2 Unit shall include LED tail lights, stop lights, turn signals, license mount with light, and all necessary reflectors.

3.1.1.9.3 A two (2) inch ball type trailer hitch 6,000 pound capacity with double safety chains in accordance with SAE J684F shall be installed.

3.1.1.9.4 Trailer shall be 12 volt DC motor, pump, valve, reservoir, manual hand pump.

3.1.1.9.5 All trailer wiring shall be encased in heavy duty hypalon type industrial wire looms clamped to underside of the trailer structural tubing.

3.1.1.9.6 Shall have a hydraulic brake actuator system and steel fenders one (1) each wheel, included on trailer.

3.1.1.9.7 Shall have Leveling Jacks: Four (4) crank type, heavy duty, industrial leveling jacks; one (1) at each corner of the trailer deck to be installed.

3.1.1.9.8 Shall have installation of trailer electrical cable and connector (Cole Hersee Pt# 12081 or equal) compatible with towing vehicles.

REQUEST FOR QUOTATION
RFQ 7013EC02 843 CLASS FULL MATRIX TRAILER MOUNTED
SOLAR POWERED MESSAGE BOARD

3.2 Contract Items Non-Mandatory Requirements; Vendor should provide Agency with the non-mandatory Contract Items listed below on an open-end and continuing basis.

3.2.1 Full-Matrix Trailer Mounted Solar Powered Message Board Non-Mandatory items.

3.2.1.3 Sign Panel – The following are non-mandatory items related to the sign panel.

3.2.1.3.1 The sign panel frame constructed of a welded assembly of aluminum alloy channel, or from steel panels power coated in a corrosion proof manner for a minimum of ten (10) years.

3.2.1.4 Power Source – The following are non-mandatory items related to the Power Source.

3.2.1.4.1 The second power supply enables the unit to accept existing 120 volt commercial electric service.

3.2.1.4.2 Batteries should be capable of being recharged by a commercial 110 volt battery.

3.2.1.5 Computer – The following are non-mandatory items related to the computer.

3.2.1.5.1 Password coding or key entry is required for control programming to present sequences messages under operator control through keyboard entry; provide control for moving arrow displays.

3.2.1.10 Paint – The following are non-mandatory items related to paint.

3.2.1.10.1 Manufacturer Standard color paint for this unit.

3.2.1.11 Advertising – The following are non-mandatory items related to advertising.

REQUEST FOR QUOTATION
RFQ 7013EC02 843 CLASS FULL MATRIX TRAILER MOUNTED
SOLAR POWERED MESSAGE BOARD

3.2.1.11.1 Manufacturer may attach a metal plate on the unit stating manufacturer, date of manufacture, serial number, model number, etc. No large decals or painted advertisements are permitted.

4. CONTRACT AWARD:

- 4.1 Contract Award:** The Contract is intended to provide Agencies with a purchase price on all Contract Items. The Contract shall be awarded to the Vendor that provides the Contract Items meeting the required specifications for the lowest overall total cost as shown on the Pricing Pages.
- 4.2 Pricing Pages:** Vendor should complete the Pricing Pages (Exhibit A) by completing the Year, Make, and Model, and inserting quoted price. Vendor should complete the Pricing Pages in their entirety as failure to do so may result in Vendor's bids being disqualified.

The Pricing Pages contain a list of the contract items and estimated purchase volume. The estimated purchase volume for each item represents the approximate volume of anticipated purchases only. No future use of the contract or any individual item is guaranteed or implied.

Notwithstanding the foregoing, The Purchasing Division may correct errors at its discretion. Vendor should type or electronically enter the information into the Pricing Pages to prevent errors in evaluation. The pricing pages were created as a Microsoft Excel document and vendor can request an electronic copy for bid purposes by sending an email request to the following address: Alan.W.Cummings@wv.gov.

5. ORDERING AND PAYMENT:

- 5.1 Ordering:** Vendor shall accept orders by regular mail, facsimile, e-mail, or any other written forms of communication.
- 5.2 Payment:** Vendor shall accept payment in accordance with the payment procedures of the State of West Virginia.

REQUEST FOR QUOTATION
RFQ 7013EC02 843 CLASS FULL MATRIX TRAILER MOUNTED
SOLAR POWERED MESSAGE BOARD

6. DELIVERY AND RETURN:

6.1 Delivery Time: Vendor shall deliver standard orders within 60 working days after orders are received. Vendor shall ship all orders in accordance with the above schedule and shall not hold orders until a minimum delivery quantity is met. A completed pilot model for inspection must be provided within 30 working day(s) after receipt of the purchase agreement by the successful vendor.

6.2 Late Delivery: The Agency placing the order under this Contract must be notified in writing if orders will be delayed for any reason. Any delay in delivery that could cause harm to an Agency will be grounds for cancellation of the delayed order, and/or obtaining the items ordered from a third party.

Any Agency seeking to obtain items from a third party under this provision must first obtain approval of the Purchasing Division.

6.3 Delivery Payment/Risk of Loss: Standard order delivery shall be F.O.B. destination to the Agency's location. Vendor shall include the cost of standard order delivery charges in its bid pricing/discount and is not permitted to charge the Agency separately for such delivery.

6.4 Representative Unit for Test: The successful vendor must (if specified) provide the DOH one (1) completed represented unit to be observed and evaluated on each order to insure compliance with specification. If requested, the time period for testing and evaluation shall be seven (7) working days following receipt of the unit. DOH will incur no obligation for deterioration of surfaces, finishes, seals, and mechanical or electrical parts on the unit resulting from operation and testing within the limits of these specifications; nor will DOH incur obligation for damage to the unit resulting from failure to meet specifications when due care and attention is given by DOH and testing is done within the limits of these specifications. Failure of the pilot unit to satisfactorily meet specifications as bid may be cause for cancellation of the purchase order, and return of the delivered unit along with all associated equipment to the vendor at the vendor's expense.

6.5 Delivery Point: Delivery point of the completed representative unit will be the WVDOH, Equipment Division, Rt. 33 and Brushy Fork Road, Buckhannon, WV 26201.

REQUEST FOR QUOTATION
RFQ 7013EC02 843 CLASS FULL MATRIX TRAILER MOUNTED
SOLAR POWERED MESSAGE BOARD

7. MISCELLANEOUS:

- 7.1 No Substitutions:** Vendor shall supply only Contract Items submitted in response to the RFQ unless a contract modification is approved in accordance with the provisions contained in this Contract.
- 7.2 Exception to Non-Mandatory Specifications:** Exception to a non-mandatory specification may be made by the bidder, providing the exception is not available from the manufacturer. Any exception must be indicated on a separate attachment and labeled as "Exceptions to Specifications" and supported by documentation from the manufacturer. The state reserves the right to waive minor irregularities in bids or specifications in accordance with §148-1-4(f) of the WV Legislative Rules and Regulations.
- 7.3 Reports:** Vendor shall provide quarterly reports and annual summaries to the Agency showing the Agency's items purchased, quantities of items purchased, and total dollar value of the items purchased. Vendor shall also provide reports, upon request, showing the items purchased during the term of this Contract, the quantity purchased for each of those items, and the total value of purchases for each of those items. Failure to supply such reports may be grounds for cancellation of this Contract.
- 7.4 Contract Manager:** During its performance of this Contract, Vendor must designate and maintain a primary contract manager responsible for overseeing Vendor's responsibilities under this Contract. The Contract manager must be available during normal business hours to address any customer service or other issues related to this Contract. Vendor should list its Contract manager and his or her contact information below.

Contract Manager: Safety Caution Equipment Company
 Telephone Number: 304-346-5521
 Fax Number: 304-346-5554
 Email Address: scesigns@aol.com

- 7.5 Operating and Service Manuals and Parts Lists:** An operator's manual must be included with each unit upon delivery. The "Equipment Preventative Maintenance Questionnaire", (Exhibit "B") must be with pilot unit upon delivery, Attn: Marcia Lee. There must be twelve (12) service/shop/maintenance manuals and 14 parts manuals; CD-ROM is preferred in lieu of parts manuals. Manuals shall be delivered upon completion of delivery of total units. Failure to do so will delay payment.

REQUEST FOR QUOTATION
RFQ 7013EC02 843 CLASS FULL MATRIX TRAILER MOUNTED
SOLAR POWERED MESSAGE BOARD

- 7.6 Training:** Manufacturers and/or dealers will be required to stage a thorough seminar on the subjects of Preventative Maintenance, Operator, and Mechanic Training. In order to keep operators and mechanics updated, the successful vendor shall conduct a minimum of 3 one day training sessions covering the operation, maintenance, trouble shooting and calibration/ programming of the hydraulic system and spreader controls with each purchase order against this open end contract. Manufacturers and/or dealers shall be required to furnish the Training Academy with one (1) Operator's Manual to be shipped direct to

WVDOH
Training Academy
P.O. Box 610
Buckhannon, West Virginia 26201

prior to delivery of the pilot unit. Training seminar to be held at the WV DOT, Equipment Division, Buckhannon, WV.

- 7.7 Preventative Maintenance & Operator Procedures:** Manufacturers and/or dealers will be required to submit to the Equipment Division, in addition to the operating and service manuals, booklets and pamphlets explaining the Preventative Maintenance and Operator Procedures to be used by the operators of this equipment, and must include such things as daily prestart inspection procedure, service schedule, and routine maintenance required, safety precautions, etc. The successful vendor shall furnish all training aids; i.e. videos, projectors as required in conducting the training.
- 7.8 Warranty and Service Policy:** The unit must be accompanied upon delivery by the unit's manufacturers executed warranty and service policy.
- 7.9 Unspecified Accessories & Features:** All parts, equipment, accessories, material, design and performance characteristics not specified herein, but which are necessary to provide a complete unit, must be furnished with each unit and required to conform to strength, quality of material, and quality of workmanship to those which are advertised and provided to the market in general by the unit industry. All parts and accessories advertised and regularly supplied as standard

REQUEST FOR QUOTATION
RFQ 7013EC02 843 CLASS FULL MATRIX TRAILER MOUNTED
SOLAR POWERED MESSAGE BOARD

shall be included, except those which would represent duplication of these specified and except those which, by specification, are not to be furnished. All standard safety features, required by Federal and State Law, shall be included.

Exhibit A

Cost Sheet
RFQ 7013EC02

Item Number	Estimated Quantity	Unit of Measure	Description	Unit Price	Total
1	21	Each	One complete unit: Full matrix trailer mounted, solar powered message board.	\$14,648.00	\$307,608.00

Vendor should also supply the year, make, and model of the following:

Full matrix trailer mounted, solar powered message board WANCO Full Matrix # WTMMB-A

EXHIBIT B

EQUIPMENT PREVENTATIVE MAINTENANCE QUESTIONNAIRE

THIS FORM MUST BE COMPLETED IN ITS ENTIRETY BY SUCCESSFUL BIDDER OR MANUFACTURER'S TECHNICAL REPRESENTATIVE PRIOR TO DELIVERY OF PILOT MODEL TO THE WVDOH.

DESCRIPTION: _____ MAKE: _____

MODEL: _____ YEAR: _____ PURCHASE AMOUNT: _____

ENGINE: MAKE: _____ MODEL: _____ FUEL TYPE: _____

HORSEPOWER: _____ CYLINDER: _____ ENGINE SERIAL: _____

COOLING SYSTEM CAPACITY: _____

BELTS: DESCRIPTION: _____ PART NUMBERS: _____

GVW: _____ AXLE CAPACITY:FRONT: _____ REAR: _____

TIRES: FRONT MAKE & SIZE: _____

REAR MAKE & SIZE: _____

DIMENSIONS OF UNIT: LENGTH: _____ WIDTH: _____ LENGTH: _____

VENDOR CONTACT PERSON: _____ PHONE: _____

PARTS:

BATTERY MAKE: _____ MODEL: _____ CCA: _____

TOP OR SIDE POST: _____ DIMENSIONS: LENGTH _____ WIDTH _____ HEIGHT _____

SPARK PLUGS OR FUEL INJECTORS MAKE: _____ PART # _____

FUEL PUMP OR INJECTION PUMP MAKE: _____ MODEL: _____

ALTERNATOR MAKE: _____ PART #: _____

STARTER MAKE: _____ PART #: _____

TURBO CHARGER MAKE: _____ PART #: _____

TRANS. MAKE: _____ MODEL: _____ AUTO/MANUAL: _____

HYDRAULIC PUMP MAKE: _____ MODEL: _____

FILTERS	MAKE	PART NO.	LUBRICANT	MANUFACTURER TYPE
OIL	_____	_____	ENGINE	_____
AIR INNER	_____	_____	TRANSMISSION	_____
AIR OUTER	_____	_____	POWER STEERING	_____
FUEL PRIMARY	_____	_____	HYDRAULIC	_____
FUEL SECONDARY	_____	_____	DIFFERENTIALS	_____
COOLANT	_____	_____	BRAKE FLUID	_____
HYDRAULIC	_____	_____	COOLANT	_____
OTHER	_____	_____	OTHER	_____



State of West Virginia
 Department of Administration
 Purchasing Division
 2019 Washington Street East
 Post Office Box 50130
 Charleston, WV 25305-0130

Solicitation

NUMBER
7013EC02

PAGE
1

ADDRESS CORRESPONDENCE TO ATTENTION OF:
 ALAN CUMMINGS
 304-558-2402

VENDOR

RFQ COPY
 TYPE NAME/ADDRESS HERE

SHIP TO

DIVISION OF HIGHWAYS
 EQUIPMENT DIVISION
 ROUTE 33
 BRUSHY FORK ROAD
 BUCKHANNON, WV
 26201 304-472-1750

DATE PRINTED
 05/30/2013

BID OPENING DATE: 06/05/2013 BID OPENING TIME 1:30PM

LINE	QUANTITY	UOP	CAT. NO.	ITEM NUMBER	UNIT PRICE	AMOUNT
ADDENDUM NO. 01						
ISSUED TO DISTRIBUTE PREBID SIGN-IN SHEET, VENDOR QUESTIONS/AGENCY RESPONSES, AND CHANGE BID OPENING DATE:						
FROM - 06/05/2013 AT 1:30 P.M.						
TO - 06/12/2013 AT 1:30 P.M.						
0001	1	EA		550-96		
TRAILER MOUNTED SOLAR MESSAGE BOARD						
***** THIS IS THE END OF RFQ 7013EC02 ***** TOTAL:						

SIGNATURE		TELEPHONE	DATE
TITLE	FEIN	ADDRESS CHANGES TO BE NOTED ABOVE	

WHEN RESPONDING TO SOLICITATION, INSERT NAME AND ADDRESS IN SPACE ABOVE LABELED 'VENDOR'

SOLICITATION NUMBER: 7013EC02

Addendum Number: 1

The purpose of this addendum is to modify the solicitation identified as ("Solicitation") to reflect the change(s) identified and described below.

Applicable Addendum Category:

- Modify bid opening date and time
- Modify specifications of product or service being sought
- Attachment of vendor questions and responses
- Attachment of pre-bid sign-in sheet
- Correction of error
- Other

Description of Modification to Solicitation:

To modify the bid opening date to 6/12/2013 at 1:30 PM

To provide answers to the questions proposed by vendors

To provide the pre-bid meeting sign-in sheet

Additional Documentation: Documentation related to this Addendum (if any) has been included herewith as Attachment A and is specifically incorporated herein by reference.

Terms and Conditions:

1. All provisions of the Solicitation and other addenda not modified herein shall remain in full force and effect.
2. Vendor should acknowledge receipt of all addenda issued for this Solicitation by completing an Addendum Acknowledgment, a copy of which is included herewith. Failure to acknowledge addenda may result in bid disqualification. The addendum acknowledgement should be submitted with the bid to expedite document processing.

ATTACHMENT A

ADDENDUM # 1 FOR PRE-BID

7013EC02

FULL MATRIX TRAILER MOUNTED SOLAR POWERED MESSAGE BOARD

The original language in contract will be listed first with question and answer to follow below.

1. 3.1.1.1.1 Be tested by AASHTO's National Transportation Product Evaluation Program (NTPEP).

Question: Precision Solar Controls: Needs wording changed?

Answer: 3.1.1.1.1 will read as: Unit must be as submitted by evaluation to AASHTO's National Transportation Product Evaluation Program (NTPEP).

2. 3.1.1.2.9 The sign shall be clearly visible a minimum of 4500 feet.

Question: Stephen Kappa: Most are 2800 feet, would you consider?

Answer: This distance of 4500 feet refers to the visibility of the sign, not the message.

3. 3.1.1.3.1 Length of sign panel shall not exceed 140 inches.

Question: Stephen Kappa: Would you consider 142 inches?

Answer: We will change to read as: 3.1.1.3.1 Length of sign panel shall not exceed 142 inches.

4. 3.1.1.4.2 Unit shall be designed to accept two (2) power sources: one (1) being a battery bank consisting of four (4) size 4D, deep cycle, lead acid 12 volt DC batteries wired in parallel.

Question: K&K Systems (Ver-Mac): Would 6 volt batteries wired in 12 volt parallel be acceptable as opposed to be 4D?

Answer: No, this is not acceptable.

5. 3.1.1.8.1 The unit shall be equipped with Interfaces: (2) RS232 9 pin D connectors and documentation on port numbers and pins. In addition, one USB Port or one Ethernet Port with USB adaptor shall be provided.

Question: K&K Systems Inc.: Are unit has it built in?

Answer: This will remain as written and must be provided.

6. 3.1.1.9.6 Shall have a hydraulic brake actuator system and steel fenders one (1) each wheel, included on trailer.

Question: WV Tractor: Steel fenders are mandatory in this spec. The last spec used in 2011 made steel fenders non-mandatory. My manufacturer uses fenders constructed of unbreakable, molded, solid color, UV stabilized high density polyethylene. They are completely closed on the inner side to protect the trailer frame. The fenders are secured to the trailer frame with zinc plated steel thread forming screws and fenders washes to facilitate easy repair or replacement. We ask that the construction of the fenders be made non-mandatory?

Answer: We will leave as mandatory but change the wording to read as: 3.1.1.9.6 Shall have hydraulic brake actuator system and fenders one (1) each wheel, included on trailer.

7. 4.Contract Award

We will add new bullet to read as:

4.3 Price Escalation: Vendor may ask for a price increase at contract renewal time. Pass through cost only will be accepted at the discretion of the WV Purchasing Division.

8. 6.1 Delivery time 60 working days after orders are received. A completed pilot model for inspection must be provided within 30 working days.

Question: Safety Caution Equipment: Requesting time frame be extended?

Answer: With all vendors in agreement we will change time frames to read:

90 working days after orders are received.

45 working days for pilot model.

**Pre-Bid Conference
SIGN IN SHEET**

[Please Print]

Request for Proposal No.: 7013EC02 Date: 5/16/13

<u>Firm & Representative Name</u>	<u>Mailing Address</u>	<u>Telephone & FAX Numbers</u>
1. <u>Neleh Supply, LLC</u> <u>Steve Malley</u>	<u>PO Box 722</u> <u>Bladensburg MD 20710</u> <u>Sales@nelehsupply.com</u>	T: <u>240-667-4030</u> F: <u>855-887-4894</u>
2. <u>UNTRACTOR CO</u> <u>Gary Gray</u>	<u>P.O. Box 473</u> <u>Charleston WV 25322</u>	T: <u>304-346-5301</u> F: <u>304-346-5305</u>
3. <u>Safety CAUTION E&C</u> <u>Jim Matheny</u>	<u>PO Box 10040</u> <u>Charleston WV 25357</u>	T: <u>304-346-5325</u> F: <u>304-346-5358</u>
4. <u>Stephen S Kappa</u> <u>TRAMO SUC DBA Kunaumi Electric</u> <u>+ Mitchwe Co</u>	<u>141 Campbells Creek Dr</u> <u>Charleston WV 25306</u>	T: <u>304-926-2650</u> F: <u>304-926-6623</u>
5. <u>Tim Keith</u> <u>R&K systems Inc</u>	<u>637 Palmetto Rd</u> <u>Tupelo, MS 38821</u>	T: <u>6888-414-3003</u> F: <u>1-662-566-7123</u>
6. <u>Tim Holman</u> <u>Work Area Prot./Protection Svc's Inc/</u> <u>Precision Solar Controls.</u>	<u>2500 Production Dr</u> <u>St Charles IL 60174</u>	T: <u>330-621-1678</u> F: <u>330-345-1852</u>
7. <u>Angie Moorman</u>	<u>DOH</u>	T: _____ F: _____
8. <u>Mike Neely</u>	<u>DOH</u>	T: _____ F: _____
9. <u>Pam Hall</u>	<u>DOH</u>	T: _____ F: _____
10. <u>MARCIA LEE</u>	<u>DOH</u>	T: _____ F: _____

Please print or write legibly. The fax number is essential to contact the attendees in a timely manner.

ADDENDUM ACKNOWLEDGEMENT FORM
SOLICITATION NO.: 7013EC02

Instructions: Please acknowledge receipt of all addenda issued with this solicitation by completing this addendum acknowledgment form. Check the box next to each addendum received and sign below. Failure to acknowledge addenda may result in bid disqualification.

Acknowledgment: I hereby acknowledge receipt of the following addenda and have made the necessary revisions to my proposal, plans and/or specification, etc.

Addendum Numbers Received:

(Check the box next to each addendum received)

<input checked="" type="checkbox"/> Addendum No. 1	<input type="checkbox"/> Addendum No. 6
<input checked="" type="checkbox"/> Addendum No. 2	<input type="checkbox"/> Addendum No. 7
<input type="checkbox"/> Addendum No. 3	<input type="checkbox"/> Addendum No. 8
<input type="checkbox"/> Addendum No. 4	<input type="checkbox"/> Addendum No. 9
<input type="checkbox"/> Addendum No. 5	<input type="checkbox"/> Addendum No. 10

I understand that failure to confirm the receipt of addenda may be cause for rejection of this bid. I further understand that any verbal representation made or assumed to be made during any oral discussion held between Vendor's representatives and any state personnel is not binding. Only the information issued in writing and added to the specifications by an official addendum is binding.

Safety Caution Equipment Company

Company

Sara Mathenees

Authorized Signature

June 12, 2013

Date

NOTE: This addendum acknowledgment should be submitted with the bid to expedite document processing.
Revised 6/8/2012

Variable Message Signs

Full-Matrix and Three-Line

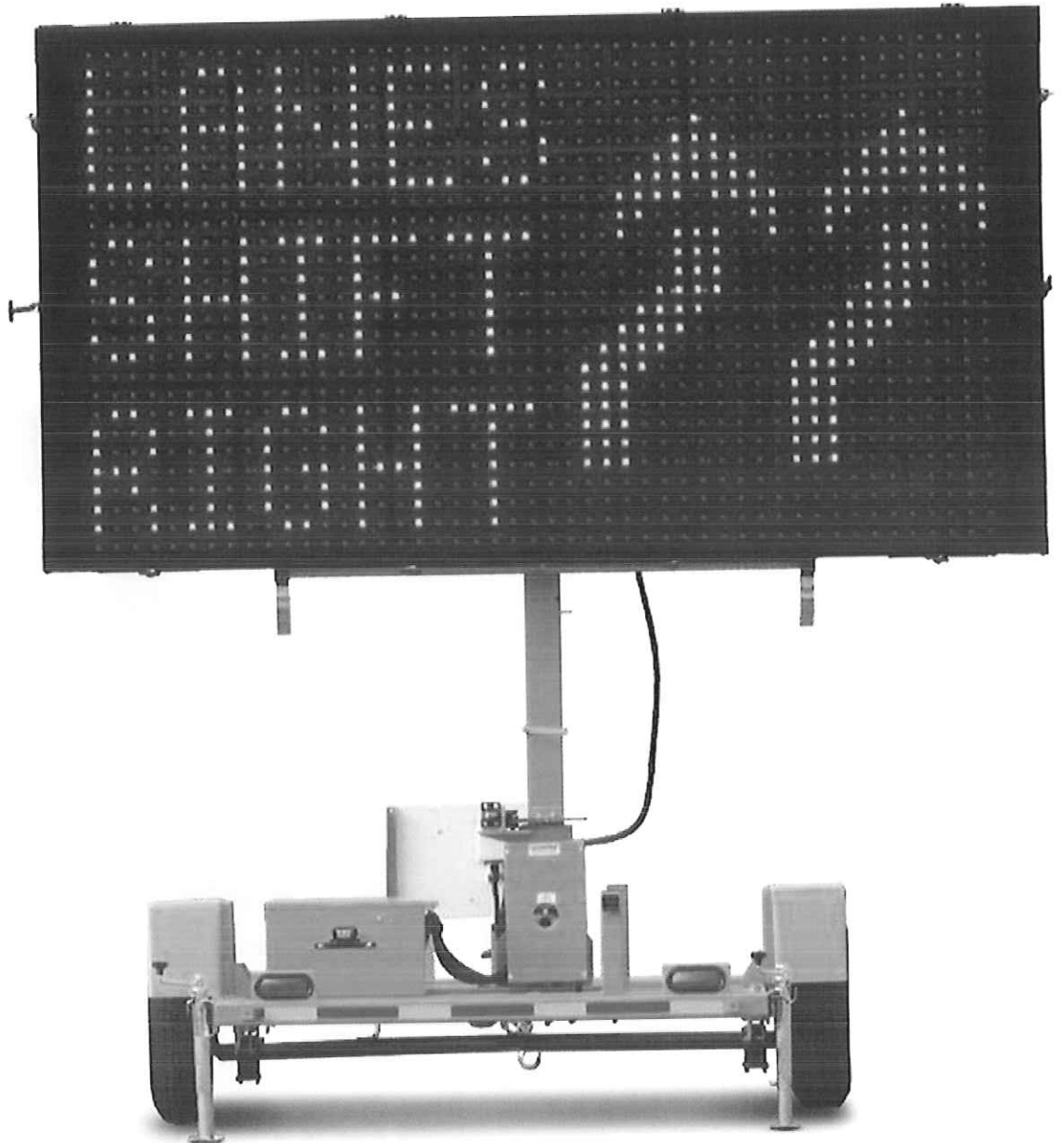

The safest means for notifying motorists of changes in traffic patterns and road conditions.

Unsurpassed quality, engineering and value, paired with a multitude of functions and options, make these signs perfect for a wide variety of applications.

- Onboard controller
- Easiest programming in the industry
- Solar charging
- Low power consumption and more uptime
- Meets MUTCD and is NTCIP-compliant

Wanco full-matrix message signs are an ideal choice when you need to get information to the public. The full matrix allows the greatest flexibility for displaying any type of message—large or small letters, symbols and graphics.

Wanco three-line message signs are capable of displaying three rows of alphanumeric characters. The three-line's highly legible, ultra-bright LEDs display your message clearly.

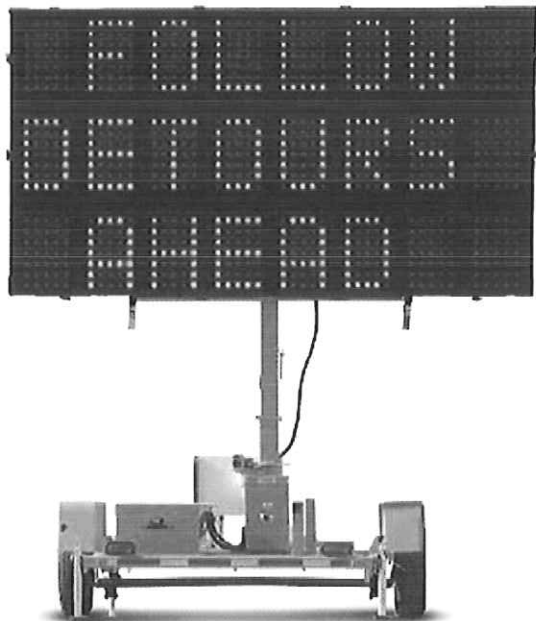

Three-Line Sign
WTLMB-(A) Hydraulic lift
WTLMB-(B) Manual winch

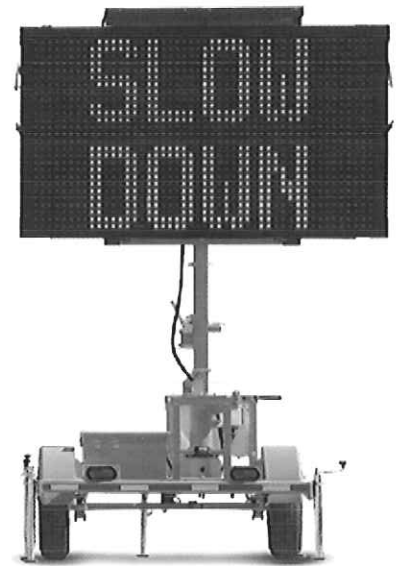

Mini Matrix Sign
WVTM(A) Hydraulic lift
WVTM(B) Manual winch

Full-Matrix Sign
(shown on front cover)
WTMMB-(A) Hydraulic lift
WTMMB-(B) Manual winch

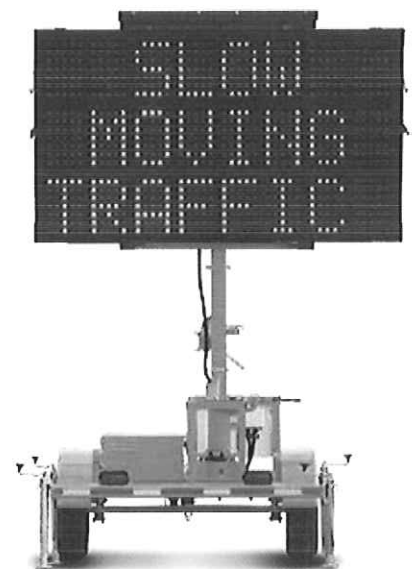

Mini Three-Line Sign
WVT3(A) Hydraulic lift
WVT3(B) Manual winch

Signs are also available in truck-mount versions. Optional accessories include radar-based speed detection and traffic data collection, remote communications, Ethernet connection, GPS and more. For details, visit www.wanco.com.

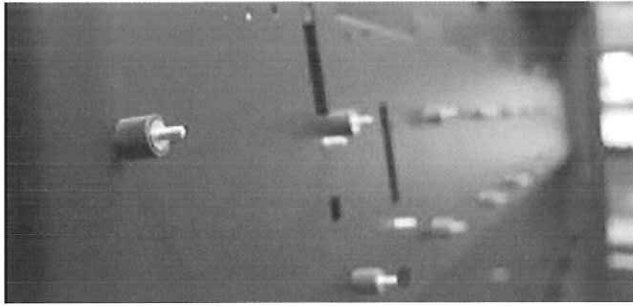

Rubber vibration-isolation mounts

Rubber vibration mounts decrease physical shock to the LED character modules and isolate them from chassis ground. This mounting technique prolongs the life of the modules, increasing both reliability and uptime.

The face of the sign cabinet is covered by an impact-resistant clear polycarbonate resin thermoplastic door that further protects the characters. The door is angled to reduce glare.

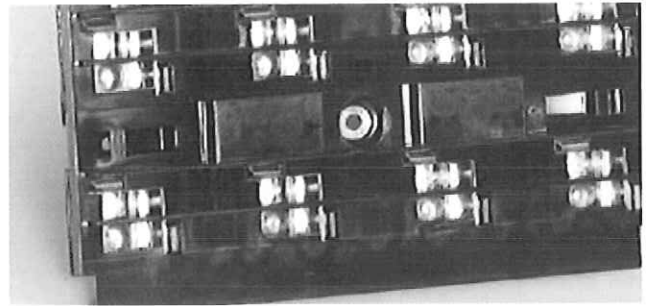

LED pixels

Characters feature clusters of four LEDs that comprise the "pixels." An optical lens over each pixel magnifies the intensity of the LEDs and increases angularity. A visor shades each row of pixels from sunlight, maximizing brightness.

All Wanco character boards feature 5-mil silicone conformal coating, to provide long-term protection against moisture and other atmospheric contaminants.

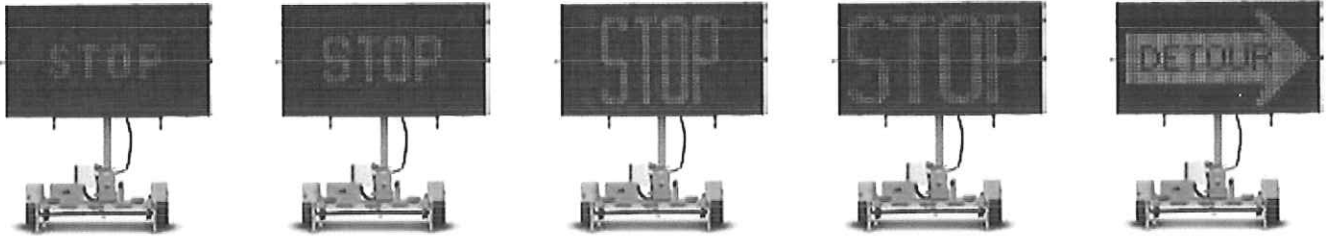

Wanco matrix signs provide a variety of font sizes and styles—many more than are shown here—as well as standard and MUTCD symbols and graphics. Signs can also be programmed to display custom graphics.

Wanco portable message signs have a self-contained onboard controller, making a laptop or external controller unnecessary.

Changing the message is simple, as Wanco signs feature the easiest programming in the industry. The control console includes a backlit LCD interface and quick-reference instructions for many common commands.

Signs come configured with preprogrammed standard messages. A quick-message function provides for display of select messages with a keystroke. Multiple programming options provide flexibility for multiple applications.

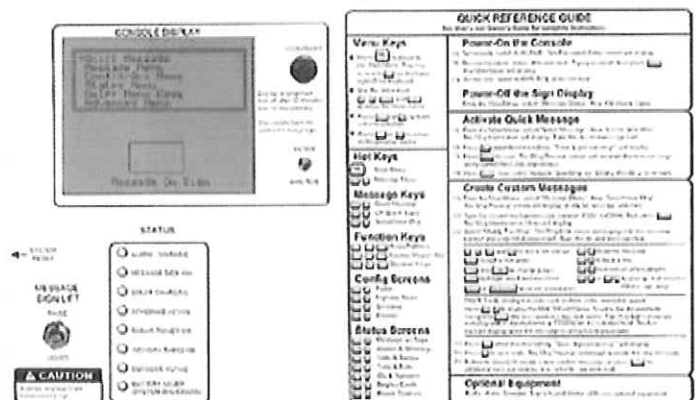

Matrix sign control panel



Unauthorized access to the control console is virtually eliminated with multiple-level password-protection, a removable keyboard, and a locking control box that deters tampering.

Brief specifications

Full-size signs

Physical

Travel Position

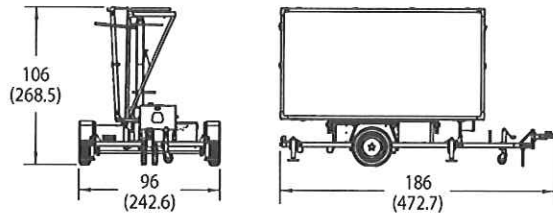

Deployed

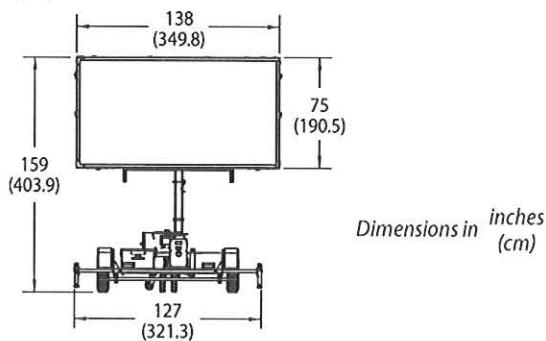

Weight Approx. 2640 lbs. (1193 kg)
Tires ST205/75 D15

Mini signs

Physical

Travel Position

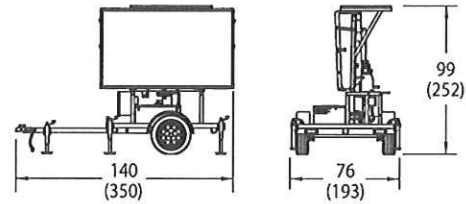

Deployed

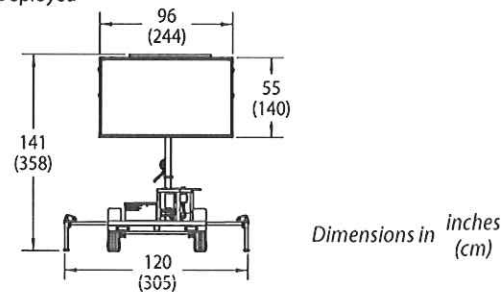

Weight Approx. 1580 lbs. (717 kg)
Tires ST205/75 D15

Matrix Signs

Display

Resolution Four amber LEDs form each pixel
Matrix 48 pixels wide, 27 pixels high
Smallest characters 4 lines, up to 12 characters per line
Largest characters 1 line, up to 6 characters

Power

Batteries Four 6 Vdc golf cart-type, wired for 12 Vdc power
Battery capacity 450 Ah total
Solar panels¹ 85 to 130 W
Options Additional batteries and solar panels
 4D AGM batteries
 Diesel engine²

¹ Depending on sign size

² Full-size signs only

Three-Line Signs

Display

Resolution Four amber LEDs form each pixel
Character size 5 pixels wide, 7 pixels high
Characters 3 lines, 8 characters per line

Power

Batteries Four 6 Vdc golf cart-type, wired for 12 Vdc power
Battery capacity 450 Ah total
Solar panels¹ 85 to 130 W
Options Additional batteries and solar panels
 4D AGM batteries

Due to Wanco's commitment to continuous improvement of our products, all information is subject to change without notice. Wanco and the Wanco logo are registered trademarks of Wanco Inc. All other trademarks are property of their respective owners.



WANCO INC.
5870 Tennyson Street
Arvada, Colorado 80003
800-972-0755
303-427-5700
303-427-5725 fax
www.wanco.com



State of West Virginia
 Department of Administration
 Purchasing Division
 2019 Washington Street East
 Post Office Box 50130
 Charleston, WV 25305-0130

Solicitation

NUMBER
7013EC02

PAGE
1

ADDRESS CORRESPONDENCE TO ATTENTION OF:
ALAN CUMMINGS 304-558-2402

VENDOR

RFQ COPY
 TYPE NAME/ADDRESS HERE

SHIP TO

DIVISION OF HIGHWAYS
 EQUIPMENT DIVISION
 ROUTE 33
 BRUSHY FORK ROAD
 BUCKHANNON, WV
 26201 304-472-1750

DATE PRINTED
06/05/2013

BID OPENING DATE: 06/12/2013 BID OPENING TIME 1:30PM

LINE	QUANTITY	UOP	CAT. NO.	ITEM NUMBER	UNIT PRICE	AMOUNT
ADDENDUM NO. 02						
ISSUED TO CLARIFY BID OPENING DATE FROM ADDENDUM NO. 01. BID OPENING DATE IS 06/12/2013 AT 1:30 P.M.						
0001	1	EA		550-96		
TRAILER MOUNTED SOLAR MESSAGE BOARD						
***** THIS IS THE END OF RFQ 7013EC02 ***** TOTAL:						

SIGNATURE		TELEPHONE	DATE
TITLE	FEIN	ADDRESS CHANGES TO BE NOTED ABOVE	

WHEN RESPONDING TO SOLICITATION, INSERT NAME AND ADDRESS IN SPACE ABOVE LABELED 'VENDOR'

SOLICITATION NUMBER: 7013ec02

Addendum Number: 2

The purpose of this addendum is to modify the solicitation identified as ("Solicitation") to reflect the change(s) identified and described below.

Applicable Addendum Category:

- | Modify bid opening date and time
- | Modify specifications of product or service being sought
- | Attachment of vendor questions and responses
- | Attachment of pre-bid sign-in sheet
- | Correction of error
- | Other

Description of Modification to Solicitation:

ISSUED TO CLARIFY BID OPENING DATE FROM ADDENDUM
NO. 01. BID OPENING DATE IS 06/12/2013 AT 1:30 P.M.

Additional Documentation: Documentation related to this Addendum (if any) has been included herewith as Attachment A and is specifically incorporated herein by reference.

Terms and Conditions:

1. All provisions of the Solicitation and other addenda not modified herein shall remain in full force and effect.
2. Vendor should acknowledge receipt of all addenda issued for this Solicitation by completing an Addendum Acknowledgment, a copy of which is included herewith. Failure to acknowledge addenda may result in bid disqualification. The addendum acknowledgement should be submitted with the bid to expedite document processing.

ATTACHMENT A

ADDENDUM ACKNOWLEDGEMENT FORM
SOLICITATION NO.: 7013ec02

Instructions: Please acknowledge receipt of all addenda issued with this solicitation by completing this addendum acknowledgment form. Check the box next to each addendum received and sign below. Failure to acknowledge addenda may result in bid disqualification.

Acknowledgment: I hereby acknowledge receipt of the following addenda and have made the necessary revisions to my proposal, plans and/or specification, etc.

Addendum Numbers Received:

(Check the box next to each addendum received)

- | | |
|--|--|
| <input checked="" type="checkbox"/> Addendum No. 1 | <input type="checkbox"/> Addendum No. 6 |
| <input checked="" type="checkbox"/> Addendum No. 2 | <input type="checkbox"/> Addendum No. 7 |
| <input type="checkbox"/> Addendum No. 3 | <input type="checkbox"/> Addendum No. 8 |
| <input type="checkbox"/> Addendum No. 4 | <input type="checkbox"/> Addendum No. 9 |
| <input type="checkbox"/> Addendum No. 5 | <input type="checkbox"/> Addendum No. 10 |

I understand that failure to confirm the receipt of addenda may be cause for rejection of this bid. I further understand that any verbal representation made or assumed to be made during any oral discussion held between Vendor's representatives and any state personnel is not binding. Only the information issued in writing and added to the specifications by an official addendum is binding.

Safety Caution Equipment Company

Company

Sera Matheny

Authorized Signature

June 12, 2013

Date

NOTE: This addendum acknowledgment should be submitted with the bid to expedite document processing.
 Revised 6/8/2012

State of West Virginia

VENDOR PREFERENCE CERTIFICATE

Certification and application* is hereby made for Preference in accordance with West Virginia Code, §5A-3-37. (Does not apply to construction contracts). West Virginia Code, §5A-3-37, provides an opportunity for qualifying vendors to request (at the time of bid) preference for their residency status. Such preference is an evaluation method only and will be applied only to the cost bid in accordance with the West Virginia Code. This certificate for application is to be used to request such preference. The Purchasing Division will make the determination of the Resident Vendor Preference, if applicable.

- 1. Application is made for 2.5% resident vendor preference for the reason checked: Bidder is an individual resident vendor and has resided continuously in West Virginia for four (4) years immediately preceding the date of this certification; or, Bidder is a partnership, association or corporation resident vendor and has maintained its headquarters or principal place of business continuously in West Virginia for four (4) years immediately preceding the date of this certification; or 80% of the ownership interest of Bidder is held by another individual, partnership, association or corporation resident vendor who has maintained its headquarters or principal place of business continuously in West Virginia for four (4) years immediately preceding the date of this certification; or, Bidder is a nonresident vendor which has an affiliate or subsidiary which employs a minimum of one hundred state residents and which has maintained its headquarters or principal place of business within West Virginia continuously for the four (4) years immediately preceding the date of this certification; or,
2. Application is made for 2.5% resident vendor preference for the reason checked: Bidder is a resident vendor who certifies that, during the life of the contract, on average at least 75% of the employees working on the project being bid are residents of West Virginia who have resided in the state continuously for the two years immediately preceding submission of this bid; or,
3. Application is made for 2.5% resident vendor preference for the reason checked: Bidder is a nonresident vendor employing a minimum of one hundred state residents or is a nonresident vendor with an affiliate or subsidiary which maintains its headquarters or principal place of business within West Virginia employing a minimum of one hundred state residents who certifies that, during the life of the contract, on average at least 75% of the employees or Bidder's affiliate's or subsidiary's employees are residents of West Virginia who have resided in the state continuously for the two years immediately preceding submission of this bid; or,
4. Application is made for 5% resident vendor preference for the reason checked: Bidder meets either the requirement of both subdivisions (1) and (2) or subdivision (1) and (3) as stated above; or,
5. Application is made for 3.5% resident vendor preference who is a veteran for the reason checked: Bidder is an individual resident vendor who is a veteran of the United States armed forces, the reserves or the National Guard and has resided in West Virginia continuously for the four years immediately preceding the date on which the bid is submitted; or,
6. Application is made for 3.5% resident vendor preference who is a veteran for the reason checked: Bidder is a resident vendor who is a veteran of the United States armed forces, the reserves or the National Guard, if, for purposes of producing or distributing the commodities or completing the project which is the subject of the vendor's bid and continuously over the entire term of the project, on average at least seventy-five percent of the vendor's employees are residents of West Virginia who have resided in the state continuously for the two immediately preceding years.
7. Application is made for preference as a non-resident small, women- and minority-owned business, in accordance with West Virginia Code §5A-3-59 and West Virginia Code of State Rules. Bidder has been or expects to be approved prior to contract award by the Purchasing Division as a certified small, women- and minority-owned business.

Bidder understands if the Secretary of Revenue determines that a Bidder receiving preference has failed to continue to meet the requirements for such preference, the Secretary may order the Director of Purchasing to: (a) reject the bid; or (b) assess a penalty against such Bidder in an amount not to exceed 5% of the bid amount and that such penalty will be paid to the contracting agency or deducted from any unpaid balance on the contract or purchase order.

By submission of this certificate, Bidder agrees to disclose any reasonably requested information to the Purchasing Division and authorizes the Department of Revenue to disclose to the Director of Purchasing appropriate information verifying that Bidder has paid the required business taxes, provided that such information does not contain the amounts of taxes paid nor any other information deemed by the Tax Commissioner to be confidential.

Under penalty of law for false swearing (West Virginia Code, §61-5-3), Bidder hereby certifies that this certificate is true and accurate in all respects; and that if a contract is issued to Bidder and if anything contained within this certificate changes during the term of the contract, Bidder will notify the Purchasing Division in writing immediately.

Bidder: Safety Caution Equipment Company

Signed: Sara Mathoney

Date: June 12, 2013

Title: President

RFQ No. 7013EC02

STATE OF WEST VIRGINIA
Purchasing Division

PURCHASING AFFIDAVIT

MANDATE: Under W. Va. Code §5A-3-10a, no contract or renewal of any contract may be awarded by the state or any of its political subdivisions to any vendor or prospective vendor when the vendor or prospective vendor or a related party to the vendor or prospective vendor is a debtor and: (1) the debt owed is an amount greater than one thousand dollars in the aggregate; or (2) the debtor is in employer default.

EXCEPTION: The prohibition listed above does not apply where a vendor has contested any tax administered pursuant to chapter eleven of the W. Va. Code, workers' compensation premium, permit fee or environmental fee or assessment and the matter has not become final or where the vendor has entered into a payment plan or agreement and the vendor is not in default of any of the provisions of such plan or agreement.

DEFINITIONS:

"Debt" means any assessment, premium, penalty, fine, tax or other amount of money owed to the state or any of its political subdivisions because of a judgment, fine, permit violation, license assessment, defaulted workers' compensation premium, penalty or other assessment presently delinquent or due and required to be paid to the state or any of its political subdivisions, including any interest or additional penalties accrued thereon.

"Employer default" means having an outstanding balance or liability to the old fund or to the uninsured employers' fund or being in policy default, as defined in W. Va. Code § 23-2c-2, failure to maintain mandatory workers' compensation coverage, or failure to fully meet its obligations as a workers' compensation self-insured employer. An employer is not in employer default if it has entered into a repayment agreement with the Insurance Commissioner and remains in compliance with the obligations under the repayment agreement.

"Related party" means a party, whether an individual, corporation, partnership, association, limited liability company or any other form or business association or other entity whatsoever, related to any vendor by blood, marriage, ownership or contract through which the party has a relationship of ownership or other interest with the vendor so that the party will actually or by effect receive or control a portion of the benefit, profit or other consideration from performance of a vendor contract with the party receiving an amount that meets or exceeds five percent of the total contract amount.

AFFIRMATION: By signing this form, the vendor's authorized signer affirms and acknowledges under penalty of law for false swearing (W. Va. Code §61-5-3) that neither vendor nor any related party owe a debt as defined above and that neither vendor nor any related party are in employer default as defined above, unless the debt or employer default is permitted under the exception above.

WITNESS THE FOLLOWING SIGNATURE:

Vendor's Name: Safety Caution Equipment Company

Authorized Signature: Sara Mathoney Date: 6-12-13

State of West Virginia

County of Kanawha, to-wit:

Taken, subscribed, and sworn to before me this 12th day of June, 2013.

My Commission expires March 26, 2014.

AFFIX SEAL HERE

NOTARY PUBLIC Jennifer Hyatt

Purchasing Affidavit (Revised 07/01/2012)



NOTE:
Vendor and Notary's date must be the same.
Notary required to AFFIX SEAL on Purchasing Affidavit.