



State of West Virginia
 Department of Administration
 Purchasing Division
 2019 Washington Street East
 Post Office Box 50130
 Charleston, WV 25305-0130

Request for Quotation

RFQ NUMBER
 PRS12011

PAGE
 1

ADDRESS CORRESPONDENCE TO ATTENTION OF:
 TARA LYLE
 304-558-2544

*506115049 724-837-5411
 CONTROL SCREENING LLC
 35 WEST PITTSBURGH ST 3RD FLR
 GREENSBURG PA 15601-5142

VENDOR

SHIP TO

PROTECTIVE SERVICES
 DIVISION OF
 BUILDING 1, ROOM 152-A
 1900 KANAWHA BOULEVARD, EAST
 CHARLESTON, WV
 25305 304-558-9911

DATE PRINTED 10/28/2011	TERMS OF SALE	SHIP VIA	F.O.B.	FREIGHT TERMS
----------------------------	---------------	----------	--------	---------------

BID OPENING DATE: 11/08/2011 BID OPENING TIME 01:30PM

LINE	QUANTITY	UOP	CAT. NO.	ITEM NUMBER	UNIT PRICE	AMOUNT
ADDENDUM NO. 1						
1. BID FORM ATTACHED.						
2. TO MOVE THE BID OPENING DATE FROM 11/03/2011 TO 11/08/2011.						
3. ADDENDUM ACKNOWLEDGEMENT IS ATTACHED. THIS DOCUMENT SHOULD BE SIGNED AND RETURNED WITH YOUR BID. FAILURE TO SIGN AND RETURN MAY RESULT IN DISQUALIFICATION OF YOUR BID.						
END OF ADDENDUM NO. 1						
C001	2	EA		680-44		
X-RAY INSPECTION SYSTEM						
***** THIS IS THE END OF RFQ PRS12011 ***** TOTAL:						

RECEIVED
 2011 NOV -7 A 11:10
 PURCHASING DIVISION
 STATE OF WV

SEE REVERSE SIDE FOR TERMS AND CONDITIONS

SIGNATURE	TELEPHONE 724-837-5411	DATE 11-03-2011
TITLE SR BUSINESS DEVELOPMENT	FEIN 222964823	ADDRESS CHANGES TO BE NOTED ABOVE

DIR: WHEN RESPONDING TO RFQ, INSERT NAME AND ADDRESS IN SPACE ABOVE LABELED 'VENDOR'

PRS12011 - DIVISION OF PROTECTIVE SERVICES

Item #	Description	QUANTITY	Unit Price	Extended Amount
	<u>AUTOCLEAR MODEL 6040-A</u>		22,885.00	45,770.00
1	Smiths HI-SCAN 6050ds Heimann X-Ray inspections system, or equal. The unit price should include the unit, 1 meter roller tables entry and exit, delivery, installation and training. ALTERNATE BID- AUTOCLEAR 6848-A	2	\$ 25,757.00	\$ 51,514.00
Failure to use this form may result in disqualification			GRAND TOTAL:	\$
Bidder / Vendor Information:				
Name: <u>AUTOCLEAR LLC / CONTROL SCREENING</u>				
Address: <u>35 W. PITTSBURGH ST. SUITE 304</u>				
<u>GREENSBURG, PA 15601-2323</u>				
Phone#: <u>724-837-5411 / 800-343-9777</u>				
Email Address: <u>DCUNNINGHAM@AUTOCLEARUS.COM</u>				

EXHIBIT 10

REQUISITION NO.: PR512011

ADDENDUM ACKNOWLEDGEMENT

I HEREBY ACKNOWLEDGE RECEIPT OF THE FOLLOWING CHECKED ADDENDUM(S) AND HAVE MADE THE NECESSARY REVISIONS TO MY PROPOSAL, PLANS AND/OR SPECIFICATION, ETC.

ADDENDUM NO.'S:

- NO. 1
- NO. 2
- NO. 3
- NO. 4
- NO. 5

I UNDERSTAND THAT FAILURE TO CONFIRM THE RECEIPT OF THE ADDENDUM(S) MAY BE CAUSE FOR REJECTION OF BIDS. VENDOR MUST CLEARLY UNDERSTAND THAT ANY VERBAL REPRESENTATION MADE OR ASSUMED TO BE MADE DURING ANY ORAL DISCUSSION HELD BETWEEN VENDOR'S REPRESENTATIVES AND ANY STATE PERSONNEL IS NOT BINDING. ONLY THE INFORMATION ISSUED IN WRITING AND ADDED TO THE SPECIFICATIONS BY AN OFFICIAL ADDENDUM IS BINDING.

.....
SIGNATURE

AUTOCLEAR/CONTROL SCREENING
.....
COMPANY

11-03-11
.....
DATE



State of West Virginia
 Department of Administration
 Purchasing Division
 2019 Washington Street East
 Post Office Box 50130
 Charleston, WV 25305-0130

Request for Quotation

RFQ NUMBER
PRS12011

PAGE
1

ADDRESS CORRESPONDENCE TO ATTENTION OF:
TARA LYLE 304-558-2544

VENDOR

Control Screening
 2 Gardner Road
 Fairfield, NJ 07004-2206

SHIP TO

PROTECTIVE SERVICES
 DIVISION OF
 BUILDING 1, ROOM 152-A
 1900 KANAWHA BOULEVARD, EAST
 CHARLESTON, WV
 25305 304-558-9911

DATE PRINTED	TERMS OF SALE	SHIP VIA	F.O.B.	FREIGHT TERMS
10/05/2011				

BID OPENING DATE: **11/03/2011** BID OPENING TIME **01:30PM**

LINE	QUANTITY	UOP	CAT NO	ITEM NUMBER	UNIT PRICE	AMOUNT
0001	2	EA		680-44 AUTOCLEAR MODEL 6040-A	\$22,885.00	\$45,770.00
				ALTERNATE BID: AUTOCLEAR MODEL 6848-A	\$25,757.00	\$51,514.00
<p>THE WEST VIRGINIA STATE PURCHASING DIVISION FOR THE AGENCY, THE WV DIVISION OF PROTECTIVE SERVICES, IS SOLICITING BIDS TO PROVIDE THE AGENCY WITH TWO (2) SMITHS HI-SCAN 6040DS HEIMANN X-RAY INSPECTION SYSTEMS OR EQUAL PER THE ATTACHED SPECIFICATIONS.</p> <p>INQUIRIES:</p> <p>WRITTEN QUESTIONS WILL BE ACCEPTED UNTIL CLOSE OF BUSINESS ON 10/21/2011. QUESTIONS MAY BE SENT VIA USPS, FAX, COURIER OR E-MAIL. IN ORDER TO ASSURE NO VENDOR RECEIVES AN UNFAIR ADVANTAGE, NO SUBSTANTIVE QUESTIONS WILL BE ANSWERED ORALLY. IF POSSIBLE, E-MAIL QUESTIONS ARE PREFERRED. ADDRESS INQUIRIES TO:</p> <p>TARA LYLE DEPARTMENT OF ADMINISTRATION PURCHASING DIVISION 2019 WASHINGTON STREET, EAST CHARLESTON, WV 25305</p> <p>FAX: 304-558-4115 EMAIL: TARA.L.LYLE@WV.GOV</p>						

SEE REVERSE SIDE FOR TERMS AND CONDITIONS

SIGNATURE	TELEPHONE	DATE
	724-837-5411	10/26/2011
TITLE	FEIN	ADDRESS CHANGES TO BE NOTED ABOVE
SR. BUSINESS DEVELOPMENT	22-296 4823	

WHEN RESPONDING TO RFQ, INSERT NAME AND ADDRESS IN SPACE ABOVE LABELED 'VENDOR'

GENERAL TERMS & CONDITIONS REQUEST FOR QUOTATION (RFQ) AND REQUEST FOR PROPOSAL (RFP)

- Awards will be made in the best interest of the State of West Virginia.
2. The State may accept or reject in part, or in whole, any bid.
 3. Prior to any award, the apparent successful vendor must be properly registered with the Purchasing Division and have paid the required \$125 fee.
 4. All services performed or goods delivered under State Purchase Order/Contracts are to be continued for the term of the Purchase Order/Contracts, contingent upon funds being appropriated by the Legislature or otherwise being made available. In the event funds are not appropriated or otherwise available for these services or goods this Purchase Order/Contract becomes void and of no effect after June 30.
 5. Payment may only be made after the delivery and acceptance of goods or services.
 6. Interest may be paid for late payment in accordance with the *West Virginia Code*.
 7. Vendor preference will be granted upon written request in accordance with the *West Virginia Code*.
 8. The State of West Virginia is exempt from federal and state taxes and will not pay or reimburse such taxes.
 9. The Director of Purchasing may cancel any Purchase Order/Contract upon 30 days written notice to the seller.
 10. The laws of the State of West Virginia and the *Legislative Rules* of the Purchasing Division shall govern the purchasing process.
 11. Any reference to automatic renewal is hereby deleted. The Contract may be renewed only upon mutual written agreement of the parties.
 12. **BANKRUPTCY:** In the event the vendor/contractor files for bankruptcy protection, the State may deem this contract null and void, and terminate such contract without further order.
 13. **HIPAA BUSINESS ASSOCIATE ADDENDUM:** The West Virginia State Government HIPAA Business Associate Addendum (BAA), approved by the Attorney General, is available online at www.state.wv.us/admin/purchase/vrc/hipaa.htm and is hereby made part of the agreement. Provided that the Agency meets the definition of a Cover Entity (45 CFR §160.103) and will be disclosing Protected Health Information (45 CFR §160.103) to the vendor.
 14. **CONFIDENTIALITY:** The vendor agrees that he or she will not disclose to anyone, directly or indirectly, any such personally identifiable information or other confidential information gained from the agency, unless the individual who is the subject of the information consents to the disclosure in writing or the disclosure is made pursuant to the agency's policies, procedures, and rules. Vendor further agrees to comply with the Confidentiality Policies and Information Security Accountability Requirements, set forth in <http://www.state.wv.us/admin/purchase/privacy/noticeConfidentiality.pdf>.
 15. **LICENSING:** Vendors must be licensed and in good standing in accordance with any and all state and local laws and requirements by any state or local agency of West Virginia, including, but not limited to, the West Virginia Secretary of State's Office, the West Virginia Tax Department, and the West Virginia Insurance Commission. The vendor must provide all necessary releases to obtain information to enable the director or spending unit to verify that the vendor is licensed and in good standing with the above entities.
 16. **ANTITRUST:** In submitting a bid to any agency for the State of West Virginia, the bidder offers and agrees that if the bid is accepted the bidder will convey, sell, assign or transfer to the State of West Virginia all rights, title and interest in and to all causes of action it may now or hereafter acquire under the antitrust laws of the United States and the State of West Virginia for price fixing and/or unreasonable restraints of trade relating to the particular commodities or services purchased or acquired by the State of West Virginia. Such assignment shall be made and become effective at the time the purchasing agency tenders the initial payment to the bidder.
- I certify that this bid is made without prior understanding, agreement, or connection with any corporation, firm, limited liability company, partnership, or person or entity submitting a bid for the same material, supplies, equipment or services and is in all respects fair and without collusion or fraud. I further certify that I am authorized to sign the certification on behalf of the bidder or this bid.

INSTRUCTIONS TO BIDDERS

1. Use the quotation forms provided by the Purchasing Division. Complete all sections of the quotation form.
2. Items offered must be in compliance with the specifications. Any deviation from the specifications must be clearly indicated by the bidder. Alternates offered by the bidder as EQUAL to the specifications must be clearly defined. A bidder offering an alternate should attach complete specifications and literature to the bid. The Purchasing Division may waive minor deviations to specifications.
3. Unit prices shall prevail in case of discrepancy. All quotations are considered F.O.B. destination unless alternate shipping terms are clearly identified in the quotation.
4. All quotations must be delivered by the bidder to the office listed below prior to the date and time of the bid opening. Failure of the bidder to deliver the quotations on time will result in bid disqualifications: Department of Administration, Purchasing Division, 2019 Washington Street East, P.O. Box 50130, Charleston, WV 25305-0130
5. Communication during the solicitation, bid, evaluation or award periods, except through the Purchasing Division, is strictly prohibited (W.Va. C.S.R. §148-1-6.6).



State of West Virginia
 Department of Administration
 Purchasing Division
 2019 Washington Street East
 Post Office Box 50130
 Charleston, WV 25305-0130

Request for Quotation

RFQ NUMBER
PRS12011

PAGE
2

ADDRESS CORRESPONDENCE TO ATTENTION OF
TARA LYLE 304-558-2544

RFQ COPY

TYPE NAME/ADDRESS HERE

CONTROL SCREENING LLC
 35 W. PITTSBURGH ST. 3RD FL
 GREENSBURG, PA 15601

PROTECTIVE SERVICES
 DIVISION OF
 BUILDING 1, ROOM 152-A
 1900 KANAWHA BOULEVARD, EAST
 CHARLESTON, WV
 25305 304-558-9911

DATE PRINTED	TERMS OF SALE	SHIP VIA	FOB	FREIGHT TERMS
10/05/2011				
BID OPENING DATE: 11/03/2011		BID OPENING TIME 01:30PM		

LINE	QUANTITY	UOP	CAT. NO.	ITEM NUMBER	UNIT PRICE	AMOUNT
<p>CANCELLATION: THE DIRECTOR OF PURCHASING RESERVES THE RIGHT TO CANCEL THIS CONTRACT IMMEDIATELY UPON WRITTEN NOTICE TO THE VENDOR IF THE COMMODITIES AND/OR SERVICE SUPPLIED ARE OF AN INFERIOR QUALITY OR DO NOT CONFORM TO THE SPECIFICATIONS OF THE BID AND CONTRACT HEREIN.</p> <p>BANKRUPTCY: IN THE EVENT THE VENDOR/CONTRACTOR FILES FOR BANKRUPTCY PROTECTION, THE STATE MAY DEEM THE CONTRACT NULL AND VOID, AND TERMINATE SUCH CONTRACT WITHOUT FURTHER ORDER.</p> <p>THE MODEL/BRAND/SPECIFICATIONS NAMED HEREIN ESTABLISH THE ACCEPTABLE LEVEL OF QUALITY ONLY AND ARE NOT INTENDED TO REFLECT A PREFERENCE OR FAVOR ANY PARTICULAR BRAND OR VENDOR. VENDORS WHO ARE BIDDING ALTERNATES SHOULD SO STATE AND INCLUDE PERTINENT LITERATURE AND SPECIFICATIONS. FAILURE TO PROVIDE INFORMATION FOR ANY ALTERNATES MAY BE GROUNDS FOR REJECTION OF THE BID. THE STATE RESERVES THE RIGHT TO WAIVE MINOR IRREGULARITIES IN BIDS OR SPECIFICATIONS IN ACCORDANCE WITH SECTION 148-1-4(F) OF THE WEST VIRGINIA LEGISLATIVE RULES AND REGULATIONS.</p> <p>VENDOR PREFERENCE CERTIFICATE</p> <p>THIS TEAM EXHIBIT HAS BEEN REPLACED BY THE ONLINE VERSION WHICH IS AVAILABLE HERE: HTTP://WWW.STATE.WV.US/ADMIN/PURCHASE/VRC/VENPREF.PDF</p> <p>NOTICE</p> <p>A SIGNED BID MUST BE SUBMITTED TO:</p>						

SEE REVERSE SIDE FOR TERMS AND CONDITIONS

SIGNATURE	TELEPHONE	DATE
	724-837-5411	11-03-2011

TITLE	FEIN	ADDRESS CHANGES TO BE NOTED ABOVE
SR. BUSINESS DEVELOPMENT	222964823	

DIRECTOR WHEN RESPONDING TO RFQ, INSERT NAME AND ADDRESS IN SPACE ABOVE LABELED 'VENDOR'



State of West Virginia
 Department of Administration
 Purchasing Division
 2019 Washington Street East
 Post Office Box 50130
 Charleston, WV 25305-0130

Request for Quotation

BID NUMBER
 PRS12011

PAGE
 3

ADDRESS CORRESPONDENCE TO ATTENTION OF
 YARA LYLE
 304-558-2544

ADDRESS

RFQ COPY
 TYPE NAME/ADDRESS HERE

CONTROL SCREENING LLC
 35 W. PITTSBURGH ST., 3RD FL
 GREENSBURG, PA 15601

SHIP TO

PROTECTIVE SERVICES
 DIVISION OF
 BUILDING 1, ROOM 152-A
 1900 KANAWHA BOULEVARD, EAST
 CHARLESTON, WV
 25305 304-558-9911

DATE PRINTED 10/05/2011	TERMS OF SALE	SHIP VIA	F.O.B.	FREIGHT TERMS
BID OPENING DATE 11/03/2011		BID OPENING TIME 01:30PM		

LINE	QUANTITY	UOP	CAT. NO.	ITEM NUMBER	UNIT PRICE	AMOUNT
DEPARTMENT OF ADMINISTRATION PURCHASING DIVISION BUILDING 15 2019 WASHINGTON STREET, EAST CHARLESTON, WV 25305-0130						
THE BID SHOULD CONTAIN THIS INFORMATION ON THE FACE OF THE ENVELOPE OR THE BID MAY NOT BE CONSIDERED: SEALED BID						
BUYER: ----- TL/32 -----						
RFQ. NO.: ----- PRS12011 -----						
BID OPENING DATE: ----- 11/03/2011 -----						
BID OPENING TIME: ----- 1:30 PM -----						
PLEASE PROVIDE A FAX NUMBER IN CASE IT IS NECESSARY TO CONTACT YOU REGARDING YOUR BID: ----- 724-837-5425 -----						
CONTACT PERSON (PLEASE PRINT CLEARLY): ----- DENNIS CUNNINGHAM -----						

SEE REVERSE SIDE FOR TERMS AND CONDITIONS

SIGNATURE: TELEPHONE: 724-837-5411 DATE: 11-03-2011
 TITLE: SR. BUSINESS DEVELOPMENT DIRECTOR FEIN: 222964823 ADDRESS CHANGES TO BE NOTED ABOVE
 WHEN RESPONDING TO RFQ, INSERT NAME AND ADDRESS IN SPACE ABOVE LABELED 'VENDOR'

000004

PRI12011
Division of Protective Services

Purchase, Delivery, Installation and Training for Two (2) Smiths HI-SCAN 6050ds Heimann X-RAY Inspections systems, or equal.

Including 1 meter roller tables entry and exit on each system and single monitor for each system.

Delivery/Installation:

1 unit at Building 7
State Capitol Complex
1900 Kanawha Blvd., East
Charleston, WV 25305

1 unit at Central Mail Facility
311 Jefferson Street
Charleston, WV 25305

Training:

Minimum of two (2) hours on-site training for each unit for a minimum of 3 people per site.

Warranty:

One year warranty on all parts and labor on site.

Award:

The contract will be awarded to the vendor with the lowest grand total meeting all of the specifications. The price of the units, delivery, installation and training should be included in the quote.

RFQ No. PRS12011

STATE OF WEST VIRGINIA
Purchasing Division

PURCHASING AFFIDAVIT

West Virginia Code §5A-3-10a states: No contract or renewal of any contract may be awarded by the state or any of its political subdivisions to any vendor or prospective vendor when the vendor or prospective vendor or a related party to the vendor or prospective vendor is a debtor and the debt owed is an amount greater than one thousand dollars in the aggregate.

DEFINITIONS:

"Debt" means any assessment, premium, penalty, fine, tax or other amount of money owed to the state or any of its political subdivisions because of a judgment, fine, permit violation, license assessment, defaulted workers' compensation premium, penalty or other assessment presently delinquent or due and required to be paid to the state or any of its political subdivisions, including any interest or additional penalties accrued thereon.

"Debtor" means any individual, corporation, partnership, association, limited liability company or any other form or business association owing a debt to the state or any of its political subdivisions. "Political subdivision" means any county commission; municipality; county board of education; any instrumentality established by a county or municipality; any separate corporation or instrumentality established by one or more counties or municipalities, as permitted by law; or any public body charged by law with the performance of a government function or whose jurisdiction is coextensive with one or more counties or municipalities. "Related party" means a party, whether an individual, corporation, partnership, association, limited liability company or any other form or business association or other entity whatsoever, related to any vendor by blood, marriage, ownership or contract through which the party has a relationship of ownership or other interest with the vendor so that the party will actually or by effect receive or control a portion of the benefit, profit or other consideration from performance of a vendor contract with the party receiving an amount that meets or exceeds five percent of the total contract amount.

EXCEPTION: The prohibition of this section does not apply where a vendor has contested any tax administered pursuant to chapter eleven of this code, workers' compensation premium, permit fee or environmental fee or assessment and the matter has not become final or where the vendor has entered into a payment plan or agreement and the vendor is not in default of any of the provisions of such plan or agreement.

Under penalty of law for false swearing (*West Virginia Code §61-5-3*), it is hereby certified that the vendor affirms and acknowledges the information in this affidavit and is in compliance with the requirements as stated.

WITNESS THE FOLLOWING SIGNATURE

Vendor's Name: CONTROL SCREENING LLC

Authorized Signature: [Signature] Date: 10/27/2011

State of PENNSYLVANIA

County of WESTMORELAND, to-wit:

Taken, subscribed, and sworn to before me this 27 day of October, 2011.

My Commission expires April 26, 2015.

AFFIX SEAL HERE

NOTARY PUBLIC [Signature]

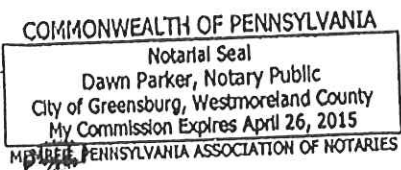

ORIGINAL MAILED WITH ORIGINAL BID 10/28/11 UPS. WE DIDN'T RECEIVE THE ADDENDUM UNTIL 10/31/11.

000008

Rev 09/08

State of West Virginia VENDOR PREFERENCE CERTIFICATE

Certification and application* is hereby made for Preference in accordance with West Virginia Code, §5A-3-37. (Does not apply to construction contracts). West Virginia Code, §5A-3-37, provides an opportunity for qualifying vendors to request (at the time of bid, preference for their residency status. Such preference is an evaluation method only and will be applied only to the cost bid in accordance with the West Virginia Code. This certificate for application is to be used to request such preference. The Purchasing Division will make the determination of the Resident Vendor Preference, if applicable.

1. **Application is made for 2.5% resident vendor preference for the reason checked:**
 Bidder is an individual resident vendor and has resided continuously in West Virginia for four (4) years immediately preceding the date of this certification; or,
 Bidder is a partnership, association or corporation resident vendor and has maintained its headquarters or principal place of business continuously in West Virginia for four (4) years immediately preceding the date of this certification; or 30% of the ownership interest of Bidder is held by another individual, partnership, association or corporation resident vendor who has maintained its headquarters or principal place of business continuously in West Virginia for four (4) years immediately preceding the date of this certification; or,
 Bidder is a nonresident vendor which has an affiliate or subsidiary which employs a minimum of one hundred state residents and which has maintained its headquarters or principal place of business within West Virginia continuously for the four (4) years immediately preceding the date of this certification; or,
2. **Application is made for 2.5% resident vendor preference for the reason checked:**
 Bidder is a resident vendor who certifies that, during the life of the contract, on average at least 75% of the employees working on the project being bid are residents of West Virginia who have resided in the state continuously for the two years immediately preceding submission of this bid; or,
3. **Application is made for 2.5% resident vendor preference for the reason checked:**
 Bidder is a nonresident vendor employing a minimum of one hundred state residents or is a nonresident vendor with an affiliate or subsidiary which maintains its headquarters or principal place of business within West Virginia employing a minimum of one hundred state residents who certifies that, during the life of the contract, on average at least 75% of the employees or Bidder's affiliate's or subsidiary's employees are residents of West Virginia who have resided in the state continuously for the two years immediately preceding submission of this bid; or,
4. **Application is made for 5% resident vendor preference for the reason checked:**
 Bidder meets either the requirement of both subdivisions (1) and (2) or subdivision (1) and (3) as stated above; or,
5. **Application is made for 3.3% resident vendor preference who is a veteran for the reason checked:**
 Bidder is an individual resident vendor who is a veteran of the United States armed forces, the reserves or the National Guard and has resided in West Virginia continuously for the four years immediately preceding the date on which the bid is submitted; or,
6. **Application is made for 3.5% resident vendor preference who is a veteran for the reason checked:**
 Bidder is a resident vendor who is a veteran of the United States armed forces, the reserves or the National Guard if, for purposes of producing or distributing the commodities or completing the project which is the subject of the vendor's bid and continuously over the entire term of the project, on average at least seventy-five percent of the vendor's employees are residents of West Virginia who have resided in the state continuously for the two immediately preceding years.

Bidder understands if the Secretary of Revenue determines that a Bidder receiving preference has failed to continue to meet the requirements for such preference, the Secretary may order the Director of Purchasing to: (a) reject the bid; or (b) assess a penalty against such Bidder in an amount not to exceed 5% of the bid amount and that such penalty will be paid to the contracting agency or deducted from any unpaid balance on the contract or purchase order.

By submission of this certificate, Bidder agrees to disclose any reasonably requested information to the Purchasing Division and authorizes the Department of Revenue to disclose to the Director of Purchasing appropriate information verifying that Bidder has paid the required business taxes, provided that such information does not contain the amounts of taxes paid nor any other information deemed by the Tax Commissioner to be confidential.

Under penalty of law for false swearing (West Virginia Code, §61-5-3), Bidder hereby certifies that this certificate is true and accurate in all respects; and that if a contract is issued to Bidder and if anything contained within this certificate changes during the term of the contract, Bidder will notify the Purchasing Division in writing immediately.

Bidder: AUTOCLEAR / CONTROL SCREENING Signed: 

Date: 11/03/11 Title: SR. BUSINESS DEVELOPMENT DIRECTOR

*Check any combination of preference consideration(s) indicated above, which you are entitled to receive.

AUTOCLEAR® 6040

Rapid Parcel X-ray for Explosives,
Weapons & Narcotics



RealClear® reveals components of a gun, knife, narcotics in bottle, and a bomb in real time, without lags or rescans. AutoScale® also uniquely displays contents at very fine resolution automatically and without distortion.

AUTOCLEAR is the world's leading producer of advanced, fast, reliable, X-ray, Weapons and Trace Detection systems. Visit us at www.autoclearus.com. Ask about our mobile, cargo, dual-view, backscatter contraband, and trace detection systems.

The AUTOCLEAR 6040 (62 cm wide x 42 cm high, 24.4" x 16.5" opening) is rapid, high penetration and ergonomic. Clearly images for:

**Airports • Ports • Courts
Customs • Military • Corporate
Government Buildings • Postal
Prisons • Nuclear
Access Control • Special Events
Police • Rail or Bus Stations**

Features & Benefits

- ➔ autoTracking® unique, guided conveyor belt system never needs adjustment, lowering operating costs.
- ➔ autoSensing® assures safety while eliminating costly, troublesome photoeye beams and footpads. Assures 100% screening of thin blades or plastique in courier envelopes or magazines, or of parcel already in tunnel during start-up.
- ➔ Narrower footprint enhances security and conveniently fits in elevators, 32" doorways, narrow halls and tight spaces; conveyor end folds up for transport.
- ➔ Ideal size, penetration and throughput for parcels, laptops, shoes, coats, electronics, food, large briefcases, handbags, backpacks, strollers and bins.
- ➔ Advanced, bright digital image. Folded array rapidly images full mailbags, long or tall parcels.
- ➔ Features fast CPU, 19" LCD monitor, RealClear®, autoScale®, autoDensAlert®, autoOutline®, autoSensing®, autoCal®, up to 64X Rapid Smart Zoom, Lighten, Help, DensityScan, and Low Density Stripping, among other features.
- ➔ TIP, Training and autoArchive also available. AutoMataAlert® option highlights bomb and threat items using atomic number and density. Multi-Energy Color with Organic/Inorganic Stripping is popular. AutoArchive option saves improved images to DVD, CD or USB flash drive.
- ➔ 160/140kV, 28-29mm penetration obviates hand searches. A base Model 400+ available with 100/90 kV. Ask about special airport conveyors, ergonomics and trim packages.
- ➔ Nearly half the radiation dose to parcels and at the tunnel curtains, with reduced energy consumption. Twice as filmsafe.
- ➔ Interactive training and highly responsive local service. All critical subassemblies designed, engineered, and rigorously tested in North America to ISO 9000-2001 and world-class standards.

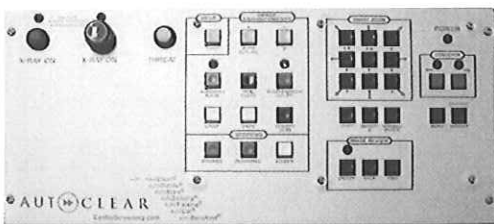

User-friendly, ergonomic, fully-featured operator control panel.

Leading contraband threat detection & field support, since 1937

AUTOCLEAR®

autoclearus.com

Scintrex® • CheckGate® • Dynavision® • Control Screening® • Federal Labs®
U.S. Canada Europe Dubai Latin America Beijing Hong Kong Singapore

Model 6040 X-ray Specifications

Overall Dimensions:	154.6 cm (60.9") L x 80.9 cm (31.9") W x 126.4 cm (49.8") H
Inspection Capabilities	
Tunnel Size:	24.4" wide (62 cm) 16.5" high (42 cm) L-shaped detector for 100% package screening. 28-29 mm (1.10 - 1.14") steel Over 2 million color tones standard.
Material Penetration:	38-40 AWG wire.
Contrast Sensitivity:	32-bit adaptive image processing with minimum 128 Mbytes or higher memory; 2.4+ GHz processor.
Resolution:	48 feet per minute; 24 cm per second. Standard conveyor pictured on reverse. Extended conveyor length, Model 6040E (variable length entrance and exit bed). Fully reversible.
Processing:	150 kg (331 lbs) (Higher pulling weights available). Belt guaranteed to autoTrack for life.
Conveyor Speed:	Guaranteed for high-speed films up to ISO 1600 (33 DIN). Reduces downtime and assures all magazines, envelopes or items are scanned, no matter how thin, or of bag already in tunnel at start-up. Enhances radiation safety.

X-ray Generator

X-ray tube head:	Self-contained, shielded tank
High voltage rating:	160 kV, 140 kV Operating Voltage
Duty cycle:	100% with sealed oil bath cooling
Beam orientation:	Diagonal (80° beam divergence)
Dose rate per exam:	0.1 mR. Lower doses available.

X-ray Detectors

Surface-mounted, multilayer, fully integrated, high frequency, solid state scintillator detectors, using state of the art high-speed processors and CPU's and advanced signal processing.

Video

Standard with color 19" LCD flat screen monitor. High resolution, flicker-free, low rad., low energy monitor, 1280 x 1024 or higher resolution. Single energy color is based on object density. Multi-Energy option available with CRT(s) or larger monitor(s), displays organics in orange and inorganics in blue, both overlapping in green and very dense objects in black, and includes Organic and Inorganic Stripping.

Standard Features

- realClear*
- autoDensAlert*
- autoTracking*
- autoSensing*
- autoOutline*
- autoScale*
- autoCal*
- 1.5, 2, 2.5, 3, 3.5, 4, 6, 8, 16, 32 and 64X Smart Zoom
- Dark & Light enhance
- DensityScan
- Color; Reverse B/W
- High/Low Density & Stripping
- High density
- Integrated undercarriage
- Brushed alum. tunnel extensions
- Helpscreens
- Fast (25 second) initial warm-up
- Full-sized, friendly, robust keyboard
- Reversible direction & image
- Non-marring castors

Options

- Multi-Energy (M) color material identification with organic and inorganic stripping (popular)
- autoArchive with autoSave* to DVD, CD, or USB Flash
- Threat Image Projection (TIP)
- autoMatalert*
- Tropical Humidity Kit
- Loading or exit slides, or rollerbeds
- CRT, dual LCD or larger monitor(s)
- Locking metal keypad cover
- Extended or motorized conveyors; added pulling power
- CE marking. UL or CSA. UK, Fr. or Can. approved
- kV, mA meter or item counter
- Power conditioner, or UPS
- Variable height brushed keypad mount
- Locking monitor(s) hood
- Remote operation; printer or archiving cables
- Built-in Training
- autoNet or TIPNet
- Stepwedge or radiation meter

Physical Details

Dimensions:	See drawing
Weight:	775 lbs (352 kg) 975 lbs (442 kg) crated
Construction:	Unibody heavy gauge, epoxy painted steel construction with stainless steel and aluminum trim and accessories. Corrosion-resistant command center keypad. Available mounted on side or on table.
Environmental Conditions:	Temperature range: 5° - 131°F, (-15° - 55°C) Humidity 20% - 95%, non-condensing. Storage to 65°C (149°F)
Electrical Power Requirements:	Consumption: < .8 kVA, 100, 120 volts AC ± 10% (<8 amps) 200, 220, 230, 240, 250 volts AC ± 10% (<4 amps). All at 50 or 60 Hz.

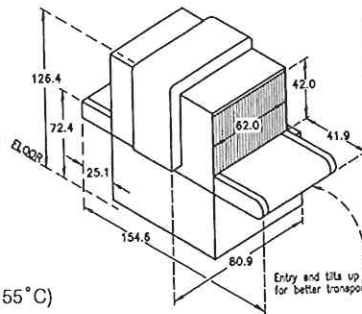

Dimensions are in centimeters
Note: Non-marring castors

www.autoclearus.com

Technology Labs & Headquarters Plant

2 Gardner Road
Fairfield, NJ 07004-2206 USA
Tel: 1 (973) 276-6161
Fax: 1 (973) 276-6162
info@autoclearus.com

Central EU

eu@autoclearus.com
Tel: + 33 2 38 61 97 00
Fax: + 33 2 38 61 97 01

Southern EU

seu@autoclearus.com

Northern EU

neu@autoclearus.com

Canada & Scintrex

info@scintrextrace.com
300 Parkdale Ave., Ottawa
Ontario, Canada K1Y 1G2
Tel: 1 (613) 224-1061
Fax: 1 (613) 224-2603

Asia Southeast & North

sasia@autoclearus.com
nasia@autoclearus.com
china@autoclearus.com

Latin America

latina@autoclearus.com

Middle East

ME@autoclearus.com
Dubai, UAE
Tel: + 971 6 557 4505
Fax: + 971 6 557 4507

Western U.S.

sw@autoclearus.com

Distributor:

ISO 9001-2000 Registered

www.autoclearus.com
www.scintrextrace.com www.fed-labs.com

Leading contraband threat detection field support, since 1937

AUTOCLEAR

autoclearus.com

Scintrex* • CheckGate* • Dynavision* • Control Screening* • Federal Labs*
U.S. Canada Europe Dubai Latin America Beijing Hong Kong Singapore

AUTOCLEAR® 6848

High Capacity Parcel X-ray for Explosives, Weapons & Narcotics



RealClear® reveals components of a gun, knife and bomb in real time, without lags and delays. autoScale® displays contents at Pentium 4 resolution automatically and without distortion.

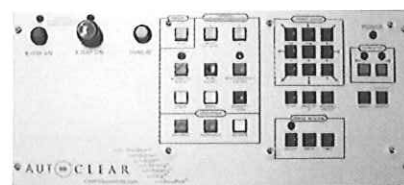

User-friendly, ergonomic and fully-featured operator control panel.

Control Screening is the leading worldwide producer of fast, reliable and sophisticated X-ray, Metal and Trace Detection screening systems. Visit us at www.controlscreening.com. Ask about our mobile and cargo systems. Our advanced systems and options are often integrated, leased or rented.

The AUTOCLEAR® 6848 (featuring a 68.0 cm wide x 48.0 cm high or 26.8" wide x 18.9" high tunnel opening) is a high capacity, high penetration, heavy-duty, conveyORIZED X-ray scanner designed to inspect carry-on bags, briefcases, mail trays and parcels. Ideal for use at:

**Airports • Seaports • Courts
Customs • Corporate Facilities
Government Buildings • Postal
Checkpoints • Loading Docks
Mailrooms • Corrections Facilities
Nuclear • Access Control
Special Events • Hospitals
Rail or Bus Stations
Police Stations • Military Bases**

Features

- ➔ autoTracking® guided conveyor belt system never needs adjustment, lowering operating costs.
- ➔ autoSensing® eliminates the need for troublesome photosensors or footpad switch. Assures 100% screening of thin blades or plastique in magazines or courier envelopes, or of bag already in tunnel at start-up.
- ➔ Parcel contents are displayed at normal scale, wherever located, automatically and without distortion (autoScale®). RealClear® function reveals components of dense items in realtime without lags or delays.
- ➔ Narrower footprint enhances security and conveniently fits in elevators, 36" doorways and tight spaces; conveyor end folds up for transport.
- ➔ Features Pentium 4, 17" monitor, RealClear®, autoScale®, autoDensAlert®, autoOutline®, autoSensing®, autoCal®, 64X Smart Zoom, Lighten, Help, DensityScan, and Low Density Stripping, among other features.
- ➔ Compact version (above) or airport version with extended conveyor(s).
- ➔ Multi-Energy Color option with Organic/Inorganic Stripping is popular. TIP, Training and Image Archiving also available. autoMataAlert®, option highlights suspect materials using atomic number and density.
- ➔ Interactive training and highly responsive local service. Engineered, made and rigorously tested in the USA to ISO 9001 and regulatory standards

Leading contraband threat detection & field support, since 1937

AUTOCLEAR®

autoclearus.com

Scintrex® • CheckGate® • Dynavision® • Control Screening® • Federal Labs®
U.S. Canada Europe Dubai Latin America Beijing Hong Kong Singapore

Model 6848 X-ray Specifications

Overall Dimensions: Inspection Capabilities

Tunnel Size:	185.4 cm (73.0") L x 88.1 cm (34.7") W x 132.7 cm (52.3") H
Material Penetration:	26.8" wide (68 cm)
Contrast Sensitivity:	18.9" high (48 cm)
Resolution:	L-shaped detector for 100% package screening.
Processing:	28-29 mm steel
Conveyor Speed:	Over 2 million color tones standard.
Pulling Weight:	40 AWG wire.
autoTracking*:	32-bit adaptive image processing with minimum 128 Mbytes memory; 800 MHz or 2.4 GHz processor.
Film Safety:	48 feet per minute; 24 cm per second. Standard conveyor pictured on reverse. Extended conveyor length, Model 6040E (variable length entrance and exit bed). Fully reversible.
Full autoSensing without photosensors, moving parts, or footpad.	150 kg (331 lbs) (Higher pulling weights available). Belt guaranteed to autoTrack for life. Guaranteed for high-speed films up to ISO 1600 (33 DIN). Reduces downtime and assures all magazines, envelopes or items are scanned, no matter how thin, or of bag already in tunnel at start-up. Enhances radiation safety.

X-ray Generator

X-ray tube head:	Self-contained, shielded tank
High voltage rating:	160 kV, 140 kV Operating Voltage
Duty cycle:	100% with sealed oil bath cooling
Beam orientation:	Diagonal (80° beam divergence)
Dose rate per exam:	0.1 mR. Lower doses available.

X-ray Detectors

Surface mounted, multilayer, fully integrated, high frequency, solid state detectors using high speed processors, and Pentium 4 image processing with Single Energy or optional Multi-Energy (M) Color.

Video

Standard with color 17" SVGA monitor. High resolution, flicker-free, .21 dot pitch, low rad. monitor, 1280 x 1024 video card. Single energy color is based on object density. Multi-Energy color option available with available second monitor or flat screen or larger monitor(s), displays organics in orange and inorganics in blue, both overlapping in green and very dense objects in black, and includes Organic and Inorganic Stripping.

Standard Features

- RealClear*
- autoDensAlert*
- autoTracking*
- autoSensing*
- autoOutline*
- autoScale*
- autoCal*
- Dark & Light enhance
- DensityScan
- Color; Reverse B/W
- High/Low Density & Stripping
- High density
- Help
- Fast (25 second) initial warm-up
- Fully functional, robust, low profile
- Reversible conveyor direction

Options

- Multi-Energy organic and inorganic color & stripping
- autoMatalert*
- Threat Image Projection (TIP)
- Rollerbed(s) or conveyor extensions
- Tropical Humidity Kit
- Image Archiving
- CE marking or UK approved
- Power conditioner, or UPS
- Table or locking monitor hood
- Locking metal keypad cover
- kV, mA meter or item counter
- LCD, dual or larger monitor(s)
- Footpad or optical on/off
- Variable height keypad mount
- Clear Lexan conveyor cover
- Remote operation, printer or VCR cable
- Built-in Training
- Rentals or leases
- autoNet
- TipNet

Physical Details

Dimensions:	See drawing
Weight:	890 lbs (403 kg) 1150 lbs (517 kg) crated
Construction:	Unibody heavy gauge, epoxy painted steel construction with stainless steel and aluminum trim and accessories. Non-marring casters and leveling jackscrews. Corrosion-resistant command center keypad mounted on side or on available table.
Environmental Conditions:	Temperature range: 32° - 104°F, (0° - 40°C) Humidity 20% - 95%, non-condensing. Storage to 65°C (149°F)
Electrical Power Requirements:	Consumption: < .6 kVA, 100, -120 volts AC ± 10% (-6 amps) 200, 220, 230, 240, 250 volts AC ± 10% (<3 amps). All at 50 or 60 Hz.

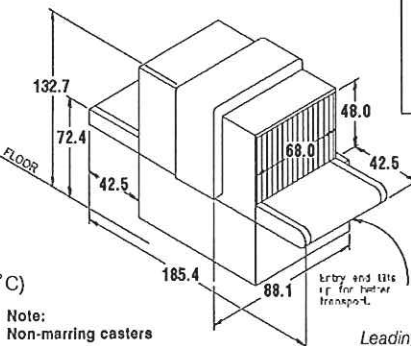

Dimensions are in centimeters

Distributor:

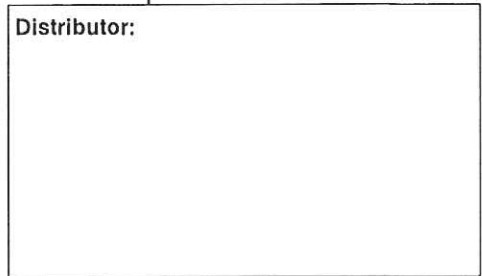

ISO 9001-2000 Certified

www.autoclearus.com
www.scintrextrace.com www.fed-labs.com

Leading contraband threat detection & field support, since 1937



autoclearus.com

Scintrex* • CheckGate* • Dynavision* • Control Screening* • Federal Labs*
U.S. Canada Europe Dubai Latin America Beijing Hong Kong Singapore

www.autoclearus.com

Technology Labs & Headquarters Plant

2 Gardner Road
Fairfield, NJ 07004-2206 USA
Tel: 1 (973) 276-6161
Fax: 1 (973) 276-6162
info@autoclearus.com

Central EU

eu@autoclearus.com
Tel: + 33 2 38 61 97 00
Fax: + 33 2 38 61 97 01

Southern EU

seu@autoclearus.com

Northern EU

neu@autoclearus.com

Canada & Scintrex

info@scintrextrace.com
300 Parkdale Ave., Ottawa
Ontario, Canada K1Y 1G2
Tel: 1 (613) 224-1061
Fax: 1 (613) 224-2603

Asia Southeast & North

sasia@autoclearus.com
nasia@autoclearus.com
china@autoclearus.com

Latin America

latina@autoclearus.com

Middle East

ME@autoclearus.com
Dubai, UAE
Tel: + 971 6 557 4505
Fax: + 971 6 557 4507

Western U.S.

sw@autoclearus.com