



State of West Virginia
 Department of Administration
 Purchasing Division
 2019 Washington Street East
 Post Office Box 50130
 Charleston, WV 25305-0130

Request for Quotation

| |
|------------|
| RFQ NUMBER |
| GSD126429 |

| |
|------|
| PAGE |
| 1 |

| |
|---|
| ADDRESS CORRESPONDENCE TO ATTENTION OF: |
| SHELLY MURRAY |
| 304-558-8801 |

*709043152 304-346-0546

ELCO MECHANICAL CONTRACTORS
 PO BOX 349

CHARLESTON WV 25322

VENDOR

SHIP TO

DEPARTMENT OF ADMINISTRATION
 GENERAL SERVICES DIVISION
 BUILDING FIVE - HIGHWAYS
 1900 KANAWHA BOULEVARD, EAST
 CHARLESTON, WV
 25305 304-558-2317

| | | | | |
|--------------|---------------|----------|--------|---------------|
| DATE PRINTED | TERMS OF SALE | SHIP VIA | F.O.B. | FREIGHT TERMS |
| 12/22/2011 | | | | |

BID OPENING DATE: 01/18/2012 BID OPENING TIME 01:30PM

| LINE | QUANTITY | UOP | CAT NO. | ITEM NUMBER | UNIT PRICE | AMOUNT |
|---|----------|-----|---------|-------------|------------|-------------------------|
| 0001 | 1 | LS | | 031-13 | | |
| VALVE REPLACEMENTS, 11TH FLOOR BOILER ROOM BLDG 5 | | | | | | SEE BID FORM PAGE 20 |
| <p>REQUEST FOR QUOTATION (RFQ) CONSTRUCTION</p> <p>THE WEST VIRGINIA STATE PURCHASING DIVISION FOR THE AGENCY, THE WEST VIRGINIA DIVISION OF GENERAL SERVICES, IS SOLICITING BIDS TO PROVIDE HVAC SERVICES AND REPAIRS IN BUILDING 5, LOCATED AT PIEDMONT ROAD/CALIFORNIA AVENUE CHARLESTON, WV PER THE ATTACHED SPECIFICATIONS.</p> <p>A MANDATORY PRE-BID MEETING WILL BE HELD ON 1/11/12 AT 10:00 AM. CONTRACTORS ATTENDING THE MEETING SHALL ASSEMBLE IN THE LOBBY OF BUILDING 5, LOCATED ON THE INTERSECTION OF CALIFORNIA AVENUE AND PIEDMONT ROAD IN CHARLESTON, WV 25305. ALL INTERESTED PARTIES ARE REQUIRED TO ATTEND THIS MEETING, FAILURE TO ATTEND THE MANDATORY PRE-BID SHALL RESULT IN DISQUALIFICATION OF THE BID. NO ONE PERSON MAY REPRESENT MORE THAN ONE BIDDER.</p> <p>AN ATTENDANCE SHEET WILL BE MADE AVAILABLE FOR ALL POTENTIAL BIDDERS TO COMPLETE. THIS WILL SERVE AS THE OFFICIAL DOCUMENT VERIFYING ATTENDANCE AT THE MANDATORY PRE-BID. FAILURE TO PROVIDE YOUR COMPANY AND REPRESENTATIVE NAME ON THE ATTENDANCE SHEET WILL RESULT IN DISQUALIFICATION OF THE BID. THE STATE WILL NOT ACCEPT ANY OTHER DOCUMENTATION TO VERIFY ATTENDANCE.</p> | | | | | | |

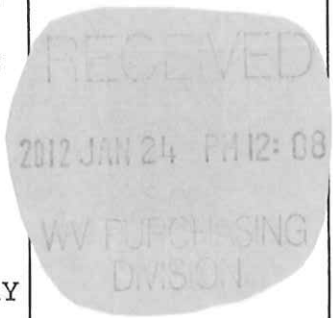

SEE REVERSE SIDE FOR TERMS AND CONDITIONS

| | | |
|-----------|--------------|-----------|
| SIGNATURE | TELEPHONE | DATE |
| | 304-346-0546 | 1-24-2012 |

| | | |
|--------|------------|-----------------------------------|
| TITLE | FEIN | ADDRESS CHANGES TO BE NOTED ABOVE |
| Member | 55-0534807 | |

WHEN RESPONDING TO RFQ, INSERT NAME AND ADDRESS IN SPACE ABOVE LABELED 'VENDOR'

GENERAL TERMS & CONDITIONS
REQUEST FOR QUOTATION (RFQ) AND REQUEST FOR PROPOSAL (RFP)

1. Awards will be made in the best interest of the State of West Virginia.
2. The State may accept or reject in part, or in whole, any bid.
3. Prior to any award, the apparent successful vendor must be properly registered with the Purchasing Division and have paid the required \$125 fee.
4. All services performed or goods delivered under State Purchase Order/Contracts are to be continued for the term of the Purchase Order/Contracts, contingent upon funds being appropriated by the Legislature or otherwise being made available. In the event funds are not appropriated or otherwise available for these services or goods this Purchase Order/Contract becomes void and of no effect after June 30.
5. Payment may only be made after the delivery and acceptance of goods or services.
6. Interest may be paid for late payment in accordance with the *West Virginia Code*.
7. Vendor preference will be granted upon written request in accordance with the *West Virginia Code*.
8. The State of West Virginia is exempt from federal and state taxes and will not pay or reimburse such taxes.
9. The Director of Purchasing may cancel any Purchase Order/Contract upon 30 days written notice to the seller.
10. The laws of the State of West Virginia and the *Legislative Rules* of the Purchasing Division shall govern the purchasing process.
11. Any reference to automatic renewal is hereby deleted. The Contract may be renewed only upon mutual written agreement of the parties.
12. **BANKRUPTCY:** In the event the vendor/contractor files for bankruptcy protection, the State may deem this contract null and void, and terminate such contract without further order.
13. **HIPAA BUSINESS ASSOCIATE ADDENDUM:** The West Virginia State Government HIPAA Business Associate Addendum (BAA), approved by the Attorney General, is available online at www.state.wv.us/admin/purchase/vrc/hipaa.html and is hereby made part of the agreement provided that the Agency meets the definition of a Cover Entity (45 CFR §160.103) and will be disclosing Protected Health Information (45 CFR §160.103) to the vendor.
14. **CONFIDENTIALITY:** The vendor agrees that he or she will not disclose to anyone, directly or indirectly, any such personally identifiable information or other confidential information gained from the agency, unless the individual who is the subject of the information consents to the disclosure in writing or the disclosure is made pursuant to the agency's policies, procedures, and rules. Vendor further agrees to comply with the Confidentiality Policies and Information Security Accountability Requirements, set forth in <http://www.state.wv.us/admin/purchase/privacy/noticeConfidentiality.pdf>.
15. **LICENSING:** Vendors must be licensed and in good standing in accordance with any and all state and local laws and requirements by any state or local agency of West Virginia, including, but not limited to, the West Virginia Secretary of State's Office, the West Virginia Tax Department, and the West Virginia Insurance Commission. The vendor must provide all necessary releases to obtain information to enable the director or spending unit to verify that the vendor is licensed and in good standing with the above entities.
16. **ANTITRUST:** In submitting a bid to any agency for the State of West Virginia, the bidder offers and agrees that if the bid is accepted the bidder will convey, sell, assign or transfer to the State of West Virginia all rights, title and interest in and to all causes of action it may now or hereafter acquire under the antitrust laws of the United States and the State of West Virginia for price fixing and/or unreasonable restraints of trade relating to the particular commodities or services purchased or acquired by the State of West Virginia. Such assignment shall be made and become effective at the time the purchasing agency tenders the initial payment to the bidder.

I certify that this bid is made without prior understanding, agreement, or connection with any corporation, firm, limited liability company, partnership, or person or entity submitting a bid for the same material, supplies, equipment or services and is in all respects fair and without collusion or fraud. I further certify that I am authorized to sign the certification on behalf of the bidder or this bid.

INSTRUCTIONS TO BIDDERS

1. Use the quotation forms provided by the Purchasing Division. Complete all sections of the quotation form.
2. Items offered must be in compliance with the specifications. Any deviation from the specifications must be clearly indicated by the bidder. Alternates offered by the bidder as **EQUAL** to the specifications must be clearly defined. A bidder offering an alternate should attach complete specifications and literature to the bid. The Purchasing Division may waive minor deviations to specifications.
3. Unit prices shall prevail in case of discrepancy. All quotations are considered F.O.B. destination unless alternate shipping terms are clearly identified in the quotation.
4. All quotations must be delivered by the bidder to the office listed below prior to the date and time of the bid opening. Failure of the bidder to deliver the quotations on time will result in bid disqualifications: Department of Administration, Purchasing Division, 2019 Washington Street East, P.O. Box 50130, Charleston, WV 25305-G130
5. Communication during the solicitation, bid, evaluation or award periods, except through the Purchasing Division, is strictly prohibited (W.Va. C.S.R. §148-1-6.6).



State of West Virginia
 Department of Administration
 Purchasing Division
 2019 Washington Street East
 Post Office Box 50130
 Charleston, WV 25305-0130

Request for Quotation

| |
|------------|
| RFQ NUMBER |
| GSD126429 |

| |
|------|
| PAGE |
| 2 |

| |
|---|
| ADDRESS CORRESPONDENCE TO ATTENTION OF: |
| SHELLY MURRAY |
| 304-558-8801 |

*709043152 304-346-0546

ELCO MECHANICAL CONTRACTORS
 PO BOX 349

CHARLESTON WV 25322

VENDOR

DEPARTMENT OF ADMINISTRATION
 GENERAL SERVICES DIVISION
 BUILDING FIVE - HIGHWAYS
 1900 KANAWHA BOULEVARD, EAST
 CHARLESTON, WV
 25305 304-558-2317

SHIP TO

| | | | | |
|--------------|---------------|----------|--------|---------------|
| DATE PRINTED | TERMS OF SALE | SHIP VIA | F.O.B. | FREIGHT TERMS |
| 12/22/2011 | | | | |

BID OPENING DATE: 01/18/2012 BID OPENING TIME 01:30PM

| LINE | QUANTITY | UOP | CAT. NO. | ITEM NUMBER | UNIT PRICE | AMOUNT |
|--|----------|-----|----------|-------------|------------|--------|
| <p>THE BIDDER IS RESPONSIBLE FOR ENSURING THEY HAVE COMPLETED THE INFORMATION REQUIRED ON THE ATTENDANCE SHEET. THE PURCHASING DIVISION AND THE STATE AGENCY WILL NOT ASSUME ANY RESPONSIBILITY FOR A BIDDER(S) FAILURE TO COMPLETE THE PRE-BID ATTENDANCE SHEET. IN ADDITION, WE REQUEST THAT ALL POTENTIAL BIDDERS INCLUDE THEIR EMAIL ADDRESS AND FAX NUMBER.</p> <p>ALL POTENTIAL BIDDERS ARE REQUESTED TO ARRIVE PRIOR TO THE STARTING TIME FOR THE PRE-BID. BIDDERS WHO ARRIVE LATE, BUT PRIOR TO THE DISMISSAL OF THE TECHNICAL PORTION OF THE PRE-BID, WILL BE PERMITTED TO SIGN IN. BIDDERS WHO ARRIVE AFTER CONCLUSION OF THE TECHNICAL PORTION OF THE PRE-BID, BUT DURING ANY SUBSEQUENT PART OF THE PRE-BID WILL NOT BE PERMITTED TO SIGN THE ATTENDANCE SHEET.</p> <p>TECHNICAL QUESTIONS CONCERNING THIS SOLICITATION MUST BE SUBMITTED IN WRITING TO KRISTA FERRELL IN THE WEST VIRGINIA STATE PURCHASING DIVISION VIA FAX AT 304-558-4115 OR VIA EMAIL AT KRISTA.S.FERRELL@WV.GOV.</p> <p>DEADLINE FOR ALL TECHNICAL QUESTIONS IS 01/13/12 AT THE CLOSE OF BUSINESS.</p> <p>ANY TECHNICAL QUESTIONS RECEIVED WILL BE ANSWERED BY FORMAL WRITTEN ADDENDUM TO BE ISSUED BY THE PURCHASING DIVISION AFTER THE DEADLINE HAS LAPSED.</p> <p>VERBAL COMMUNICATION: ANY VERBAL COMMUNICATION BETWEEN THE VENDOR AND ANY STATE PERSONNEL IS NOT BINDING, INCLUDING THAT MADE AT THE MANDATORY PRE-BID MEETING. ONLY INFORMATION ISSUED IN WRITING AND ADDED TO THE RFQ SPECIFICATIONS BY AN OFFICAL WRITTEN ADDENDUM BY PURCHASING IS BINDING.</p> | | | | | | |

SEE REVERSE SIDE FOR TERMS AND CONDITIONS

| | | |
|-----------|-----------|-----------------------------------|
| SIGNATURE | TELEPHONE | DATE |
| TITLE | FEIN | ADDRESS CHANGES TO BE NOTED ABOVE |

WHEN RESPONDING TO RFQ, INSERT NAME AND ADDRESS IN SPACE ABOVE LABELED 'VENDOR'



State of West Virginia
 Department of Administration
 Purchasing Division
 2019 Washington Street East
 Post Office Box 50130
 Charleston, WV 25305-0130

Request for Quotation

| |
|------------|
| RFQ NUMBER |
| GSD126429 |

| |
|------|
| PAGE |
| 3 |

| |
|---|
| ADDRESS CORRESPONDENCE TO ATTENTION OF: |
| SHELLY MURRAY |
| 304-558-8801 |

*709043152 304-346-0546

ELCO MECHANICAL CONTRACTORS
 PO BOX 349

CHARLESTON WV 25322

VENDOR

SHIP TO

DEPARTMENT OF ADMINISTRATION
 GENERAL SERVICES DIVISION
 BUILDING FIVE - HIGHWAYS
 1900 KANAWHA BOULEVARD, EAST
 CHARLESTON, WV
 25305 304-558-2317

| | | | | |
|--------------|---------------|----------|--------|---------------|
| DATE PRINTED | TERMS OF SALE | SHIP VIA | F.O.B. | FREIGHT TERMS |
| 12/22/2011 | | | | |

BID OPENING DATE: 01/18/2012 BID OPENING TIME 01:30PM

| LINE | QUANTITY | UOP | CAT. NO. | ITEM NUMBER | UNIT PRICE | AMOUNT |
|--|----------|-----|----------|-------------|------------|--------|
| <p>NO CONTACT BETWEEN THE VENDOR AND THE AGENCY IS PERMITTED WITHOUT THE EXPRESS WRITTEN CONSENT OF THE STATE BUYER. VIOLATION MAY RESULT IN REJECTION OF THE BID. THE STATE BUYER LISTED ABOVE IS THE SOLE CONTACT FOR ANY AND ALL INQUIRIES AFTER THIS RFQ HAS BEEN RELEASED.</p> <p>EXHIBIT 5</p> <p>WEST VIRGINIA CODE 21-1D-5 PROVIDES THAT: ANY SOLICITATION FOR A PUBLIC IMPROVEMENT CONSTRUCTION CONTRACT REQUIRES EACH VENDOR THAT SUBMITS A BID FOR THE WORK TO SUBMIT AT THE SAME TIME AN AFFIDAVIT OF COMPLIANCE WITH THE BID. THE ENCLOSED DRUG-FREE WORKPLACE AFFIDAVIT MUST BE SIGNED AND SUBMITTED WITH THE BID AS EVIDENCE OF THE VENDOR'S COMPLIANCE WITH THE PROVISIONS OF ARTICLE 1D, CHAPTER 21 OF THE WEST VIRGINIA CODE. FAILURE TO SUBMIT THE SIGNED DRUG-FREE WORKPLACE AFFIDAVIT WITH THE BID SHALL RESULT IN DISQUALIFICATION OF SUCH BID.</p> <p>NOTICE TO PROCEED: THIS CONTRACT IS TO BE PERFORMED WITHIN 30 CALENDAR DAYS AFTER THE NOTICE TO PROCEED IS RECEIVED. UNLESS OTHERWISE SPECIFIED, THE FULLY EXECUTED PURCHASE ORDER WILL BE CONSIDERED NOTICE TO PROCEED.</p> <p>CANCELLATION: THE DIRECTOR OF PURCHASING RESERVES THE RIGHT TO CANCEL THIS CONTRACT IMMEDIATELY UPON WRITTEN NOTICE TO THE VENDOR IF THE MATERIALS OR WORKMANSHIP SUPPLIED ARE OF AN INFERIOR QUALITY OR DO NOT CONFORM WITH THE SPECIFICATIONS OF THE BID AND CONTRACT HERE IN.</p> <p>WAGE RATES: THE CONTRACTOR OR SUBCONTRACTOR SHALL PAY THE HIGHER OF THE U.S. DEPARTMENT OF LABOR MINIMUM WAGE RATES AS ESTABLISHED FOR KANAWHA COUNTY, PURSUANT</p> | | | | | | |

SEE REVERSE SIDE FOR TERMS AND CONDITIONS

| | | |
|-----------|-----------|------|
| SIGNATURE | TELEPHONE | DATE |
|-----------|-----------|------|

| | | |
|-------|------|-----------------------------------|
| TITLE | FEIN | ADDRESS CHANGES TO BE NOTED ABOVE |
|-------|------|-----------------------------------|

WHEN RESPONDING TO RFQ, INSERT NAME AND ADDRESS IN SPACE ABOVE LABELED 'VENDOR'



State of West Virginia
 Department of Administration
 Purchasing Division
 2019 Washington Street East
 Post Office Box 50130
 Charleston, WV 25305-0130

Request for Quotation

| |
|------------|
| RFQ NUMBER |
| GSD126429 |

| |
|------|
| PAGE |
| 4 |

| |
|---|
| ADDRESS CORRESPONDENCE TO ATTENTION OF: |
| SHELLY MURRAY |
| 304-558-8801 |

*709043152 304-346-0546

ELCO MECHANICAL CONTRACTORS
 PO BOX 349

CHARLESTON WV 25322

VENDOR

DEPARTMENT OF ADMINISTRATION
 GENERAL SERVICES DIVISION
 BUILDING FIVE - HIGHWAYS
 1900 KANAWHA BOULEVARD, EAST
 CHARLESTON, WV
 25305 304-558-2317

SHIP TO

| | | | | |
|--------------|---------------|----------|--------|---------------|
| DATE PRINTED | TERMS OF SALE | SHIP VIA | F.O.B. | FREIGHT TERMS |
| 12/22/2011 | | | | |

BID OPENING DATE: 01/18/2012 BID OPENING TIME 01:30PM

| LINE | QUANTITY | UOP | CAT. NO. | ITEM NUMBER | UNIT PRICE | AMOUNT |
|---|----------|-----|----------|-------------|------------|--------|
| | | | | | | |
| <p>TO WEST VIRGINIA CODE 21-5A, ET, SEQ. (PREVAILING WAGE RATES APPLY TO THIS PROJECT)</p> <p>ARBITRATION: ANY REFERENCES MADE TO ARBITRATION OR INTEREST FOR PAYMENTS DUE (EXCEPT FOR ANY INTEREST REQUIRED BY STATE LAW) CONTAINED IN THIS CONTRACT OR IN ANY AMERICAN INSTITUTE OF ARCHITECTS DOCUMENTS PERTAINING TO THIS CONTRACT ARE HEREBY DELETED.</p> <p>WORKERS' COMPENSATION: VENDOR IS REQUIRED TO PROVIDE A CERTIFICATE FROM WORKERS' COMPENSATION IF SUCCESSFUL.</p> <p>ALL OF THE ITEMS CHECKED BELOW WILL BE A REQUIREMENT OF THIS CONTRACT:</p> <p>(XX) INSURANCE: SUCCESSFUL VENDOR SHALL FURNISH PROOF OF COMMERCIAL GENERAL LIABILITY INSURANCE PRIOR TO ISSUANCE OF CONTRACT. UNLESS OTHERWISE SPECIFIED IN THE BID DOCUMENTS, THE MINIMUM AMOUNT OF INSURANCE COVERAGE REQUIRED IS \$250,000.</p> <p>() BUILDERS RISK INSURANCE: SUCCESSFUL VENDOR SHALL FURNISH PROOF OF BUILDERS RISK - ALL RISK INSURANCE IN AN AMOUNT EQUAL TO 100% OF THE AMOUNT OF THE CONTRACT.</p> <p>(XX) BONDS: FIVE PERCENT (5%) OF THE TOTAL AMOUNT OF THE BID PAYABLE TO THE STATE OF WEST VIRGINIA, SHALL BE SUBMITTED WITH EACH BID AS A BID BOND. THE SUCCESSFUL BIDDER SHALL ALSO FURNISH A PERFORMANCE BOND AND LABOR/MATERIAL BOND FOR 100% OF THE AMOUNT OF THE CONTRACT. BONDS MAY BE PROVIDED IN THE FORM OF A CERTIFIED CHECK, IRREVOCABLE LETTER OF CREDIT, OR BOND FURNISHED BY A SOLVENT SURETY COMPANY AUTHORIZED TO DO BUSINESS IN THE STATE OF WEST VIRGINIA. A LETTER OF CREDIT SUBMITTED IN LIEU OF A BOND WILL ONLY BE ALLOWED FOR PROJECTS UNDER \$100,000. PERSONAL OR BUSINESS CHECKS ARE NOT</p> | | | | | | |

SEE REVERSE SIDE FOR TERMS AND CONDITIONS

| | | |
|-----------|-----------|------|
| SIGNATURE | TELEPHONE | DATE |
|-----------|-----------|------|

| | | |
|-------|------|-----------------------------------|
| TITLE | FEIN | ADDRESS CHANGES TO BE NOTED ABOVE |
|-------|------|-----------------------------------|

WHEN RESPONDING TO RFQ, INSERT NAME AND ADDRESS IN SPACE ABOVE LABELED 'VENDOR'



State of West Virginia
 Department of Administration
 Purchasing Division
 2019 Washington Street East
 Post Office Box 50130
 Charleston, WV 25305-0130

Request for Quotation

| |
|------------|
| RFQ NUMBER |
| GSD126429 |

| |
|------|
| PAGE |
| 5 |

| |
|---|
| ADDRESS CORRESPONDENCE TO ATTENTION OF: |
| SHELLY MURRAY |
| 304-558-8801 |

*709043152 304-346-0546

ELCO MECHANICAL CONTRACTORS
 PO BOX 349

CHARLESTON WV 25322

VENDOR

DEPARTMENT OF ADMINISTRATION
 GENERAL SERVICES DIVISION
 BUILDING FIVE - HIGHWAYS
 1900 KANAWHA BOULEVARD, EAST
 CHARLESTON, WV
 25305 304-558-2317

SHIP TO

| | | | | |
|--------------|---------------|----------|--------|---------------|
| DATE PRINTED | TERMS OF SALE | SHIP VIA | F.O.B. | FREIGHT TERMS |
| 12/22/2011 | | | | |

BID OPENING DATE: 01/18/2012 BID OPENING TIME 01:30PM

| LINE | QUANTITY | UOP | CAT. NO. | ITEM NUMBER | UNIT PRICE | AMOUNT |
|------|----------|-----|----------|--|------------|--------|
| | | | | ACCECPTABLE IN LIEU OF THE 5% BID BOND, PERFORMANCE BOND, OR LABOR AND MATERIAL BOND. | | |
| | | | | () MAINTENANCE BOND: A TWO (2) YEAR MAINTENANCE BOND COVERING THE ROOFING SYSTEM WILL BE A REQUIREMENT OF THE SUCCESSFUL VENDOR. | | |
| | | | | REV. 11/00 | | |
| | | | | EXHIBIT 7 | | |
| | | | | DOMESTIC ALUMINUM, GLASS & STEEL IN PUBLIC WORKS PROJECTS | | |
| | | | | IN ACCORDANCE WITH WEST VIRGINIA CODE 5-19-1 ET., SEQ., EVERY CONTRACT FOR CONSTRUCTION, RECONSTRUCTION, ALTERATION, REPAIR, IMPROVEMENT OR MAINTENANCE OF PUBLIC WORKS, WHERE THE COST IS MORE THAN \$50,000 AND, IN THE CASE OF STEEL ONLY, WHERE THE COST OF STEEL IS MORE THAN \$50,000 OR WHERE MORE THAN 10,000 POUNDS OF STEEL ARE REQUIRED, THE STATE WILL ACCEPT ONLY ALUMINUM GLASS, OR STEEL PRODUCTS PRODUCED IN THE UNITED STATES. IN ADDITION, ITEMS OF MACHINERY OR EQUIPMENT PURCHASED FOR USE AT THE SITE OF PUBLIC WORKS SHALL BE MADE OF DOMESTIC ALUMINUM, GLASS OR STEEL, UNLESS THE COST OF THE PRODUCT IS LESS THAN \$50,000 OR LESS THAN 10,000 POUNDS OF STEEL ARE USED IN PUBLIC WORKS PROJECTS. | | |
| | | | | FOREIGN MADE ALUMINUM, GLASS OR STEEL PRODUCTS MAY BE ACCEPTED ONLY IF THE COST OF DOMESTIC PRODUCTS IS FOUND TO BE UNREASONABLE. SUCH COST IS UNREASONABLE IF IT IS 20% OR MORE HIGHER THAN THE BID PRICE FOR FOREIGN MADE PRODUCTS. IF THE DOMESTIC ALUMINUM, GLASS OR STEEL PRODUCTS TO BE SUPPLIED OR PRODUCED IN A "SUBSTANTIAL LABOR SURPLUS AREA", AS DEFINED BY THE UNITED STATES | | |

SEE REVERSE SIDE FOR TERMS AND CONDITIONS

| | | |
|-----------|-----------|-----------------------------------|
| SIGNATURE | TELEPHONE | DATE |
| TITLE | FEIN | ADDRESS CHANGES TO BE NOTED ABOVE |

WHEN RESPONDING TO RFQ, INSERT NAME AND ADDRESS IN SPACE ABOVE LABELED 'VENDOR'



State of West Virginia
 Department of Administration
 Purchasing Division
 2019 Washington Street East
 Post Office Box 50130
 Charleston, WV 25305-0130

Request for Quotation

| |
|------------|
| RFQ NUMBER |
| GSD126429 |

| |
|------|
| PAGE |
| 6 |

| |
|---|
| ADDRESS CORRESPONDENCE TO ATTENTION OF: |
| SHELLY MURRAY |
| 304-558-8801 |

*709043152 304-346-0546

VENDOR

ELCO MECHANICAL CONTRACTORS
 PO BOX 349

CHARLESTON WV 25322

SHIP TO

DEPARTMENT OF ADMINISTRATION
 GENERAL SERVICES DIVISION
 BUILDING FIVE - HIGHWAYS
 1900 KANAWHA BOULEVARD, EAST
 CHARLESTON, WV
 25305 304-558-2317

| | | | | |
|--------------|---------------|----------|--------|---------------|
| DATE PRINTED | TERMS OF SALE | SHIP VIA | F.O.B. | FREIGHT TERMS |
| 12/22/2011 | | | | |

BID OPENING DATE: 01/18/2012 BID OPENING TIME 01:30PM

| LINE | QUANTITY | UOP | CAT. NO. | ITEM NUMBER | UNIT PRICE | AMOUNT |
|--|----------|-----|----------|-------------|------------|--------|
| <p>DEPARTMENT OF LABOR, FOREIGN PRODUCTS MAY BE SUPPLIED ONLY IF DOMESTIC PRODUCTS ARE 30% OR MORE HIGHER IN PRICE THAN THE FOREIGN MADE PRODUCTS.</p> <p>IF, PRIOR TO THE AWARD OF A CONTRACT UNDER THE ABOVE PROVISIONS, THE SPENDING OFFICER OF THE SPENDING UNIT DETERMINES THAT THERE EXISTS A BID FOR LIKE FOREIGN ALUMINUM, GLASS OR STEEL THAT IS REASONABLE AND LOWER THAN THE LOWEST BID DOMESTIC PRODUCTS, THE SPENDING OFFICE MAY REQUEST, IN WRITING, A REEVALUATION AND REDUCTION IN THE LOWEST BID FOR SUCH DOMESTIC PRODUCTS. ALL VENDORS MUST INDICATE IN THEIR BID IF THEY ARE SUPPLYING FOREIGN ALUMINUM, GLASS OR STEEL.</p> <p>REV. 3/88</p> <p>EXHIBIT 9</p> <p>NOTICE FOR ISSUANCE & ACKNOWLEDGEMENT OF CONSTRUCTION PROJECT ADDENDA</p> <p>THE ARCHITECT/ENGINEER AND/OR AGENCY SHALL BE REQUIRED TO ABIDE BY THE FOLLOWING SCHEDULE IN ISSUING CONSTRUCTION PROJECT ADDENDA FOR STATE AGENCIES:</p> <p>(1) THE ARCHITECT/ENGINEER SHALL PREPARE THE ADDENDUM AND A LIST OF ALL PARTIES THAT HAVE PROCURED DRAWINGS AND SPECIFICATIONS FOR THE PROJECT. THE ADDENDUM AND LIST SHALL BE FORWARDED TO THE BUYER IN THE STATE PURCHASING DIVISION. THE ARCHITECT/ENGINEER SHALL ALSO SEND A COPY OF THE ADDENDUM TO THE STATE AGENCY FOR WHICH THE CONTRACT IS ISSUED.</p> <p>(2) THE BUYER SHALL SEND THE ADDENDUM TO ALL INTERESTED PARTIES AND, IF NECESSARY, EXTEND THE BID</p> | | | | | | |

SEE REVERSE SIDE FOR TERMS AND CONDITIONS

| | | |
|-----------|-----------|------|
| SIGNATURE | TELEPHONE | DATE |
|-----------|-----------|------|

| | | |
|-------|------|-----------------------------------|
| TITLE | FEIN | ADDRESS CHANGES TO BE NOTED ABOVE |
|-------|------|-----------------------------------|

WHEN RESPONDING TO RFQ, INSERT NAME AND ADDRESS IN SPACE ABOVE LABELED 'VENDOR'



State of West Virginia
 Department of Administration
 Purchasing Division
 2019 Washington Street East
 Post Office Box 50130
 Charleston, WV 25305-0130

Request for Quotation

| |
|------------|
| RFQ NUMBER |
| GSD126429 |

| |
|------|
| PAGE |
| 7 |

| |
|---|
| ADDRESS CORRESPONDENCE TO ATTENTION OF: |
| SHELLY MURRAY |
| 304-558-8801 |

*709043152 304-346-0546

ELCO MECHANICAL CONTRACTORS
 PO BOX 349

CHARLESTON WV 25322

VENDOR

SHIP TO

DEPARTMENT OF ADMINISTRATION
 GENERAL SERVICES DIVISION
 BUILDING FIVE - HIGHWAYS
 1900 KANAWHA BOULEVARD, EAST
 CHARLESTON, WV
 25305 304-558-2317

| | | | | |
|--------------|---------------|----------|--------|---------------|
| DATE PRINTED | TERMS OF SALE | SHIP VIA | F.O.B. | FREIGHT TERMS |
| 12/22/2011 | | | | |

BID OPENING DATE: 01/18/2012 BID OPENING TIME 01:30PM

| LINE | QUANTITY | UOP | CAT. NO. | ITEM NUMBER | UNIT PRICE | AMOUNT |
|---|----------|-----|----------|-------------|------------|--------|
| <p>OPENING DATE. ANY ADDENDUM SHOULD BE RECEIVED BY THE BUYER WITHIN FOURTEEN (14) DAYS PRIOR TO THE BID OPENING DATE.</p> <p>(3) ALL ADDENDA SHOULD BE FORMALLY ACKNOWLEDGED BY ALL BIDDERS AND SUBMITTED TO THE STATE PURCHASING DIVISION. THE SAME RULES AND REGULATIONS THAT APPLY TO THE ORIGINAL BIDDING DOCUMENT SHALL ALSO APPLY TO AN ADDENDUM DOCUMENT. THE ONLY EXCEPTION MAY BE FOR AN ADDENDUM THAT IS ISSUED FOR THE SOLE PURPOSE OF CHANGING A BID OPENING TIME AND/OR DATE.</p> <p>REV. 11/96</p> <p>EXHIBIT 10</p> <p>ADDENDUM ACKNOWLEDGEMENT</p> <p>I HEREBY ACKNOWLEDGE RECEIPT OF THE FOLLOWING CHECKED ADDENDUM(S) AND HAVE MADE THE NECESSARY REVISIONS TO MY PROPOSAL, PLANS AND/OR SPECIFICATION, ETC.</p> <p>ADDENDUM NOS. :</p> <p>NO. 1 .. 1/18/2012</p> <p>NO. 2 ..</p> <p>NO. 3 ..</p> <p>NO. 4 ..</p> <p>NO. 5 ..</p> | | | | | | |

SEE REVERSE SIDE FOR TERMS AND CONDITIONS

| | | |
|-----------|-----------|------|
| SIGNATURE | TELEPHONE | DATE |
|-----------|-----------|------|

| | | |
|-------|------|-----------------------------------|
| TITLE | FEIN | ADDRESS CHANGES TO BE NOTED ABOVE |
|-------|------|-----------------------------------|

WHEN RESPONDING TO RFQ, INSERT NAME AND ADDRESS IN SPACE ABOVE LABELED 'VENDOR'



State of West Virginia
 Department of Administration
 Purchasing Division
 2019 Washington Street East
 Post Office Box 50130
 Charleston, WV 25305-0130

Request for Quotation

| |
|------------|
| RFQ NUMBER |
| GSD126429 |

| |
|------|
| PAGE |
| 8 |

| |
|---|
| ADDRESS CORRESPONDENCE TO ATTENTION OF: |
| SHELLY MURRAY |
| 304-558-8801 |

*709043152 304-346-0546

VENDOR

ELCO MECHANICAL CONTRACTORS
 PO BOX 349

CHARLESTON WV 25322

SHIP TO

DEPARTMENT OF ADMINISTRATION
 GENERAL SERVICES DIVISION
 BUILDING FIVE - HIGHWAYS
 1900 KANAWHA BOULEVARD, EAST
 CHARLESTON, WV
 25305 304-558-2317

| | | | | |
|----------------------------|---------------|----------|--------|---------------|
| DATE PRINTED 12/22/2011 | TERMS OF SALE | SHIP VIA | F.O.B. | FREIGHT TERMS |
|----------------------------|---------------|----------|--------|---------------|

BID OPENING DATE: 01/18/2012 BID OPENING TIME 01:30PM

| LINE | QUANTITY | UOP | CAT. NO. | ITEM NUMBER | UNIT PRICE | AMOUNT |
|--|----------|-----|----------|-------------|------------|--------|
| <p>I UNDERSTAND THAT FAILURE TO CONFIRM THE RECEIPT OF THE ADDENDUM(S) MAY BE CAUSE FOR REJECTION OF THE BIDS.</p> <p>VENDOR MUST CLEARLY UNDERSTAND THAT ANY VERBAL REPRESENTATION MADE OR ASSUMED TO BE MADE DURING ANY ORAL DISCUSSION HELD BETWEEN VENDOR'S REPRESENTATIVES AND ANY STATE PERSONNEL IS NOT BINDING. ONLY THE INFORMATION ISSUED IN WRITING AND ADDED TO THE SPECIFICATIONS BY AN OFFICIAL ADDENDUM IS BINDING.</p> <p>..... <i>Ronald G. King</i>..... SIGNATURE</p> <p>..... <i>Elco Mechanical</i>..... COMPANY</p> <p>..... <i>1/24/2012</i>..... DATE</p> <p>REV. 11/96</p> <p>CONTRACTORS LICENSE</p> <p>WEST VIRGINIA STATE CODE 21-11-2 REQUIRES THAT ALL PERSONS DESIRING TO PERFORM CONTRACTING WORK IN THIS STATE MUST BE LICENSED. THE WEST VIRGINIA CONTRACTORS LICENSING BOARD IS EMPOWERED TO ISSUE THE CONTRACTORS LICENSE. APPLICATIONS FOR A CONTRACTORS LICENSE MAY BE MADE BY CONTACTING THE WEST VIRGINIA DIVISION OF LABOR CAPITOL COMPLEX, BUILDING 3, ROOM 319, CHARLESTON, WV 25305. TELEPHONE: (304) 558-7890.</p> <p>WEST VIRGINIA STATE CODE 21-11-11 REQUIRES ANY PROSPECTIVE BIDDER TO INCLUDE THE CONTRACTORS LICENSE NUMBER ON THEIR BID.</p> <p>BIDDER TO COMPLETE:</p> | | | | | | |

SEE REVERSE SIDE FOR TERMS AND CONDITIONS

| | | |
|-----------|-----------|------|
| SIGNATURE | TELEPHONE | DATE |
|-----------|-----------|------|

| | | |
|-------|------|-----------------------------------|
| TITLE | FEIN | ADDRESS CHANGES TO BE NOTED ABOVE |
|-------|------|-----------------------------------|

WHEN RESPONDING TO RFQ, INSERT NAME AND ADDRESS IN SPACE ABOVE LABELED 'VENDOR'



State of West Virginia
 Department of Administration
 Purchasing Division
 2019 Washington Street East
 Post Office Box 50130
 Charleston, WV 25305-0130

Request for Quotation

| |
|------------|
| RFQ NUMBER |
| GSD126429 |

| |
|------|
| PAGE |
| 9 |

| |
|---|
| ADDRESS CORRESPONDENCE TO ATTENTION OF: |
| SHELLY MURRAY 304-558-8801 |

*709043152 304-346-0546

VENDOR

ELCO MECHANICAL CONTRACTORS
 PO BOX 349

CHARLESTON WV 25322

SHIP TO

DEPARTMENT OF ADMINISTRATION
 GENERAL SERVICES DIVISION
 BUILDING FIVE - HIGHWAYS
 1900 KANAWHA BOULEVARD, EAST
 CHARLESTON, WV
 25305 304-558-2317

| | | | | |
|--------------|---------------|----------|--------|---------------|
| DATE PRINTED | TERMS OF SALE | SHIP VIA | F.O.B. | FREIGHT TERMS |
| 12/22/2011 | | | | |

BID OPENING DATE: 01/18/2012 BID OPENING TIME 01:30PM

| LINE | QUANTITY | UOP | CAT. NO. | ITEM NUMBER | UNIT PRICE | AMOUNT |
|--|----------|-----|----------|-------------|------------|--------|
| <p>CONTRACTORS NAME: <i>Elco Mechanical Contractors</i></p> <p>CONTRACTORS LICENSE NO.: <i>WV002087</i></p> <p>THE SUCCESSFUL BIDDER WILL BE REQUIRED TO FURNISH A COPY OF THEIR CONTRACTORS LICENSE PRIOR TO ISSUANCE OF A PURCHASE ORDER/CONTRACT</p> <p>APPLICABLE LAW</p> <p>THE WEST VIRGINIA STATE CODE, PURCHASING DIVISION RULE AND REGULATIONS, AND THE INFORMATION PROVIDED IN THE "REQUEST FOR QUOTATION" ISSUED BY THE PURCHASING DIVISION IS THE SOLE AUTHORITY GOVERNING THIS PROCUREMENT.</p> <p>ANY INFORMATION PROVIDED IN SPECIFICATION MANUALS, OR ANY OTHER SOURCE, VERBAL OR WRITTEN, WHICH CONTRADICTS OR ALTERS THE INFORMATION PROVIDED FROM THE SOURCES AS DESCRIBED IN THE ABOVE PARAGRAPH IS VOID AND OF NO EFFECT.</p> <p>BANKRUPTCY: IN THE EVENT THE VENDOR/CONTRACTOR FILES FOR BANKRUPTCY PROTECTION, THE STATE MAY DEEM THE CONTRACT NULL AND VOID, AND TERMINATE SUCH CONTRACT WITHOUT FURTHER ORDER.</p> <p>REV. 5/2009</p> <p>NOTICE</p> <p>A SIGNED BID MUST BE SUBMITTED TO:</p> <p>DEPARTMENT OF ADMINISTRATION</p> | | | | | | |

SEE REVERSE SIDE FOR TERMS AND CONDITIONS

| | | |
|-----------|-----------|-----------------------------------|
| SIGNATURE | TELEPHONE | DATE |
| TITLE | FEIN | ADDRESS CHANGES TO BE NOTED ABOVE |

WHEN RESPONDING TO RFQ, INSERT NAME AND ADDRESS IN SPACE ABOVE LABELED 'VENDOR'



State of West Virginia
 Department of Administration
 Purchasing Division
 2019 Washington Street East
 Post Office Box 50130
 Charleston, WV 25305-0130

Request for Quotation

| |
|------------|
| RFQ NUMBER |
| GSD126429 |

| |
|------|
| PAGE |
| 11 |

| |
|---|
| ADDRESS CORRESPONDENCE TO ATTENTION OF: |
| SHELLY MURRAY |
| 304-558-8801 |

*709043152 304-346-0546

VENDOR

ELCO MECHANICAL CONTRACTORS
 PO BOX 349
 CHARLESTON WV 25322

SHIP TO

DEPARTMENT OF ADMINISTRATION
 GENERAL SERVICES DIVISION
 BUILDING FIVE - HIGHWAYS
 1900 KANAWHA BOULEVARD, EAST
 CHARLESTON, WV
 25305 304-558-2317

| | | | | |
|----------------------------|---------------|----------|--------|---------------|
| DATE PRINTED 12/22/2011 | TERMS OF SALE | SHIP VIA | F.O.B. | FREIGHT TERMS |
|----------------------------|---------------|----------|--------|---------------|

BID OPENING DATE: 01/18/2012 BID OPENING TIME 01:30PM

| LINE | QUANTITY | UOP | CAT. NO. | ITEM NUMBER | UNIT PRICE | AMOUNT |
|---|----------|-----|----------|-------------|------------|-------------------------|
| ***** THIS IS THE END OF RFQ GSD126429 ***** TOTAL: | | | | | | SEE BID FORM PAGE 20 |

SEE REVERSE SIDE FOR TERMS AND CONDITIONS

| | | |
|-----------|-----------|-----------------------------------|
| SIGNATURE | TELEPHONE | DATE |
| TITLE | FEIN | ADDRESS CHANGES TO BE NOTED ABOVE |

WHEN RESPONDING TO RFQ, INSERT NAME AND ADDRESS IN SPACE ABOVE LABELED 'VENDOR'

State of West Virginia
Department of Administration

General Services Division
Building 5 HVAC
valve replacement

REQUEST FOR QUOTATIONS

Building 5 HVAC STEAM VALVE REPLACEMENT
Charleston, West Virginia

Location: West Virginia State Office Building 5
California Avenue & Piedmont Road
Charleston, West Virginia 25301

For: State of West Virginia
General Services Division
1900 Kanawha Blvd; East
Charleston, West Virginia 25305

All inquiries for specification clarification shall be addressed to:

Krista Ferrell, Buyer Supervisor
Purchasing Division
P. O. Box 50130
Charleston, West Virginia 25305-0130
Telephone: (304) 558-2596
Fax: (304) 558-4115
Krista.S.Ferrell@wv.gov

The Acquisition and Contract Administration Section of the Purchasing Division "State" for the West Virginia General Services Division is soliciting quotations to provide HVAC Services and repairs as specified in the attached documents in Building 5 located at Piedmont Road/California Avenue Charleston, West Virginia. This document is intended to supplement information provided in the standard "Request for Quotation" and "General Terms and Conditions" issued by the Purchasing Division for this project. Vendors should carefully review all documents.

Mandatory Pre-Bid Meeting:

A mandatory pre-bid conference will be held on Wednesday 1/11/2012, at 10:00 am. Contractors attending the meeting shall assemble in the lobby of Building 5. No parking is provided for attendees by the Agency. See Purchasing Division Request for Quotation for additional information.

Scope of Work:

The work consists of replacing Sixteen (16) hot water control valves within the 11th floor Boiler Plant Room of Building #5. Valves that will be replaced are PC5 thru PC-20. Valves shall be NIBCO 2" BALL VALVE #T-580-CS-R-66 (or EQUAL). All valves will be load tested to 100% operational capability.

State of West Virginia
Department of Administration

General Services Division
Building 5 HVAC
valve replacement

The work schedule shall be reviewed and approved by the Agency Project Manager prior to commencement of the work. The Contractor shall coordinate the schedule around the Agency's work requirements.

Contractor shall furnish all materials, labor, and equipment necessary to complete all work as indicated by these specifications. The intent is that 16 new valves in the 11th floor boiler room are installed and load tested to achieve full operating capacity. Contractor shall furnish any incidental work, materials, labor and equipment that are necessary to complete the work, even if such incidental work is not explicitly included in the contract documents.

Any equipment or material contracted for prior to receipt of the signed purchase order and written Notice to Proceed letter shall be at the Bidder's risk.

Documents:

This Request for Quotations also incorporates the attached documents:

1. The WV Purchasing Division "Request for Quotation" and "General Terms and Conditions".
2. Attachment A: Bid Form
3. Attachment B: Valve specification- T-580-CS-R-66

Contract Period:

The Contract shall be completed within THIRTY (30) calendar days from the issuance of the written Notice to Proceed. In accordance with the West Virginia State Code 5A-3-4(8), vendor agrees that liquidated damages shall be imposed at the rate of \$250.00 per day for failure to complete the project within the contract period. This clause shall in no way be considered exclusive and shall not limit the State or Agency's right to pursue any other additional remedy to which the State or Agency may have legal cause for action including further damages against the vendor.

Reference Requirement:

Bidders shall supply, with their bid, at least three references indicating their capabilities to perform such work. References shall include the name, location, and HVAC system used in the building in addition to the name, address and telephone number of a contact person with the building's owner familiar with the work.

Qualifications:

The Contractor shall have the minimum qualifications outlined below to perform the services specified under this Contract. The Contractor shall provide the Agency all documentation of the qualifications in line 1 prior to award (see Bid Form and Section labeled "Reference Requirement" above).

State of West Virginia
Department of Administration

General Services Division
Building 5 HVAC
valve replacement

1. The Contractor must provide letters of reference for at least three (3) distinct contracts documenting the successful completion of repair and warranty service for the equipment type currently serving Building 5.

Work under this Contract may only be performed by a mechanic who has first provided documentation of certifications and or licensure for the following:

1. Electricians- WV Master Electricians License
2. Plumbers- WV Master Plumbers License
3. HVAC- EPA 608 Certification and Apprentice Certification or Completion of HVAC Vocational Program prior to January 1, 2006

Definitions:

- A. The "Agency" shall be defined as The Department of Administration, General Services Division, State Capitol Complex, Building 1, Room MB-60, Charleston, West Virginia 25305.
- B. "Contractor" shall be defined as the successful bidder or vendor.
- C. The "Contract" shall be defined as the binding agreement that is entered into between the State of West Virginia and the Contractor to provide the services as herein specified.
- D. "Agency Representative" shall be defined as the person designated by the Director of the General Services Division as having authority to act on behalf of the General Services Division.
- E. "Holidays" shall be defined as days designated by W.Va. Code §2-2-1 as legal holidays (i.e. new Year's Day, Martin Luther King's Birthday, President's Day, Memorial Day, West Virginia Day, Independence Day, Labor Day, Columbus Day, Veteran's Day, Thanksgiving Day, Lincoln's Day, Election Days, and Christmas Day).
- F. "Testing" shall be defined as a function test upon the completion of ordered services to ensure equipment is returned to normal operating mode or to determine if additional repairs are required.

Payment:

Invoices shall be submitted for payment (in arrears) and must include the following information:

1. Invoice must include invoice date, service dates, FEIN number, complete address of vendor and Master Contract number.
2. Invoices shall be mailed to the following address:

State of West Virginia
Department of Administration

General Services Division
Building 5 HVAC
valve replacement

General Services Division
1900 Kanawha Blvd. E.
Building 1, Room MB-68
Attn: Business Manager
Charleston, WV 25305

All work shall be inspected and approved prior to payment.

Supplementary General Conditions:

A. The qualified Contractor shall satisfactorily perform all specified work outlined in the Scope of Work and further described in the drawings, specifications or other attachments. Authorization to perform the work described herein must be approved in writing by issuance of the Notice to Proceed and signed by the Agency Representative.

B. The Contractor shall procure all necessary permits and licenses to comply with all applicable laws, Federal, State, or municipal, along with all regulations, and ordinances of any regulating body.

C. The relationship of the Contractor to the Owner shall be that of an independent contractor and no principal-agent relationship or employer-employee relationship is contemplated or created by the parties to this Contract. The Contractor as an independent contractor is solely liable for the acts and omissions of its employees and agents. The Contractor will be responsible for selecting, supervising, and compensating any and all individuals employed pursuant to the terms of this contract. Neither the Contractor nor any employees or sub-contractors of the Contractor will be deemed to be employees for the State for any purposes whatsoever. The wages and salaries, taxes, withholding payments, penalties, fees, fringe benefits, professional liability insurance premiums, contributions to insurance and pension or other deferred obligations, and licensing fees, etc., and the filing of all necessary documents, forms and returns pertinent to all of the foregoing are the Contractor's responsibility.

D. The Contractor will hold harmless the State, and must provide the State and Agency with a defense against any and all claims including but not limited to the foregoing payments, withholdings, contributions, taxes, social security taxes and employer income tax returns. The Contractor will not assign, convey, transfer, sub-contract, or delegate any of its responsibilities and obligations under this contract to any person, corporation, partnership, association or entity without expressed written consent of the Agency.

E. Indemnification: The Contractor agrees to indemnify, defend, and hold harmless the State and the Owner, their officers, and employees from and against (1) Any claims or losses for services rendered by any subcontractor, person or firm performing or supplying services, materials, or supplies in connection with the performance of the Contract; (2) Any claims or losses resulting to any person or entity injured or damaged by the Contractor, its officers, employees, or subcontractors by the publication, translation, reproduction, delivery, performance, use, or disposition of any data used under the Contract in a manner not authorized by the Contract, or by Federal or State statutes or regulations; (3) Any failure of the Contractor, its officers, employees or sub-contractors to observe State and Federal laws, including but not limited to labor and wage laws.

State of West Virginia
Department of Administration

General Services Division
Building 5 HVAC
valve replacement

F. This contract will be governed by the laws of the State of West Virginia. The Contractor further agrees to comply with the Civil Rights Act of 1964 and all other applicable Federal, State, and local Government regulations.

H. The Contractor will pay any applicable sales, use, or personal property taxes arising out of this contract and the transactions contemplated thereby. Any other taxes levied upon this Contract, the transaction, or the equipment, or services delivered pursuant hereto shall be borne by the Contractor. It is clearly understood that the State of West Virginia is exempt from any taxes regarding performance of the scope of work of this Contract.

I. Contractor will be responsible for parts and materials as follows:

- 1) The Contractor will supply all tools, tool accessories, personal safety equipment, and supplies necessary to execute the responsibilities of this Contract. Contractor will be responsible for the removal and disposal of all waste and debris from Owner's property as a result of performing this contract.
- 2) Contractor will be responsible for all mileage and travel costs, including travel time, associated with the performance of this contract.
- 3) Unless greater warranties are specified elsewhere in this RFQ, the Contractor shall include a minimum one (1) year labor and materials warranty on all work performed.

J. Any work to be performed to successfully execute the terms of this Contract by a third party or sub-contractor must be pre-approved by the Owner or their Representative or Designee. All such work, after Owners approval, will remain the sole responsibility of the successful bidder/Contractor with regard to all labor, materials, fees associated with the sub-contracting and any/all associated responsibilities. Under no circumstances will the Contractor transfer responsibility for any work as described herein by a third party or sub-contractor.

Bonds and Insurance:

Refer to Purchasing Division's 'Request for Quotation' for requirements on bonding; insurance; wage rates; "Foreign made aluminum, glass and steel in Public Works Projects", and other project requirements.

General Requirements:

Submittals: N/A

Project Closeout:

1. Final cleanup shall be completed prior to final acceptance.
2. Submit warranty documents to Agency Project Manager.
3. Perform final inspection with the Agency Project Manager.

State of West Virginia
Department of Administration

General Services Division
Building 5 HVAC
valve replacement

Final Inspection:

The Final Inspection will be conducted by a Project Manager from the Agency. Work found to be in accordance with the Contract Documents will be accepted as complete for final acceptance. Unacceptable work, or work not in accordance with the Contract Documents shall be removed, replaced, changed or cleaned as required to meet requirements of Contract Documents prior to final acceptance. Final Acceptance does not waive or release Contractor to conform to the Contract Documents.

Final payment shall not be made until all work is finally accepted.

Limits of Work:

Work areas will be limited to those spaces required for access to the building.

Some interior space may be utilized for temporary (overnight) storage of equipment and tools. Coordinate storage needs with the Agency Project Manager.

Agency facilities shall remain in use during this contract. Contractor shall work with the Building Manager and Protective Services to coordinate the temporary access to work areas and otherwise provide for the Contractor needs to complete work. Contractor shall minimize disruption to building work areas and loading dock access.

Use of Facilities:

Contractor shall be permitted reasonable use of building utilities including power, water and sanitary sewage disposal as required for conducting the work. Contractor shall coordinate the location of service connections or use of receptacles with the Building Manager to avoid overloading existing circuits.

Contractor Schedule:

The Contractor shall provide the Agency Project Manager with an overall project schedule within seventy-two (72) hours of Award of the Contract. The proposed project schedule shall indicate areas to be worked. Where coordination or disruption of office workspaces or occupants may be required, provide at least one week's advance notice prior to conducting work in those areas. Contractor shall adhere to schedule provided and coordinate through the Agency Project Manager.

Waste Removal:

The Contractor shall be required to leave the work area clean upon completion of work daily. Contractor shall make arrangements for the collection and disposal of Contractor's waste and construction related debris. Debris shall be removed on a daily basis.

Contractor Visitor Badges:

Contractor shall provide a list of all personnel working on this project within the Building. This list shall include a copy of a valid driver's license or other legal identification and

State of West Virginia
Department of Administration

General Services Division
Building 5 HVAC
valve replacement

include date of birth and cell phone number. All proposed workers may be subjected to a criminal history / driver's license background check prior to being permitted to work in state buildings. Workers shall carry valid Contractor Photo ID Badges to be worn when working in the building. Under no circumstances shall a worker be assigned to this project without the validation first being submitted to the General Services Division and approval given.

Work Restrictions:

Work shall be generally performed inside the existing building between normal business hours of 7:00 am to 5:00 pm, Monday through Friday, except state recognized holidays. Weekends may be permitted when pre-arranged with the Agency Project Manager.

This is a non-smoking building. Smoking is not permitted within the building or near entrances, operable windows or outdoor air intakes.

Parking:

No parking is available on the project site. Parking in non-designated areas is not permitted. Parking is the responsibility of the contractor. With prior approval, contractor's vehicles may be brought on-site for loading & unloading or to provide equipment necessary for conducting the work.

Use of loading dock areas or sidewalk areas for parking is strictly prohibited.

Building Access:

Building 5 is available from 7:00 am to 5:00 pm. Extended work hours or schedules may be arranged if acceptable and approved by the agency. Building 5 is a secure location. Access to the building shall be coordinated with the Owner. Contractor shall not leave open doors unattended and shall close doors when not in use.

Codes:

All work is to be performed in compliance with applicable Federal and State codes including but not limited to the International Building Code, International Mechanical Code, Life Safety Code, NEC, OSHA, UL, ANSI, ASME and related standards.

Safety:

All applicable local safety and OSHA rules and guidelines shall be met by the Contractor. Work shall be subject to verification and inspection by GSD Safety representatives. Such verification shall not relieve the Contractor from meeting all applicable safety regulations and inspection by other agencies.

Notify Owner if suspected hazardous materials are encountered. Any areas requiring abatement will be provided by the GSD under separate contract.

State of West Virginia
Department of Administration

General Services Division
Building 5 HVAC
valve replacement

Hot Work Permit:

Contractor shall obtain Owner's permission prior to performing any work that requires an open flame, creates sparks, use's equipment that creates combustible temperatures, or performs any work that could result in a fire hazard. Owner will review work area and issue a 'Hot Work Permit' prior to Contractor commencing work. Note that the Contractor must take proper precautions and may be required to provide a Fire Watch as a condition of the permit.

Workmanship:

Contractor shall complete all work in a neat and workmanlike manner. All work shall be done using new materials in a manner that meets commercial quality standards. Work shall be neat, true, plumb and square, as applicable. Contractor shall verify all dimensions.

Warranty:

A one year warranty on labor and materials or the manufacturer's warranty, whichever is greater, are required.

State of West Virginia
Department of Administration

General Services Division
GSD126429 Bldg 5, 11th Floor
HVAC Valve Replacement

GSD126429 Attachment A: Bid Form

Bidder's Company Name: ELCO MECHANICAL CONTRACTORS

Bidder's Address: 1510 COONSKIN DR

CHARLESTON, WV 25311

Remittance Address: P.O. Box 349
(if different)

CHARLESTON, WV 25322

Phone Number: 304-346-0546

Fax Number: 304-346-0548

Email Address: ELCO@SUDDENLINKMAIL.COM

WV Contractor's License Number: WV002087

We, the undersigned, having examined the site and being familiar with the local conditions affecting the cost of the work and also being familiar with the general conditions to bidders, drawings, and specifications, hereby propose to furnish all materials, equipment, and labor to complete all work in a workmanlike manner, as described in the Bidding Documents.

TOTAL CONTRACT BID (Total to be written in words and numbers)

SIXTEEN THOUSAND FOUR HUNDRED SIXTY FOUR AND ⁰⁰/₁₀₀ DOLLARS

(\$ 16,464.00)

State of West Virginia
 Department of Administration

General Services Division
 GSD126429 Bldg 5, 11th Floor
 HVAC Valve Replacement

References

Reference Name: RICHARDY BECKNER
 Position: FAC. ENGINEER
 Address: ST. FRANCIS HOSPITAL 333 LINDLEY ST. CHAR. WV 25301
 Telephone Number: 304-347-6500
 Project Name: VARIOUS
 Project Description: BOILER MAINTENANCE AND REPAIR

Reference Name: GARY RICHARDS
 Position: PLANT MAINTENANCE ENGR.
 Address: ARMSTRONG ENGINEERING FIRMS SPENCER, WV
 Telephone Number: 304-927-1380
 Project Name: VARIOUS
 Project Description: BOILER MAINTENANCE & REPAIR

Reference Name: TIM LEE
 Position: FACILITIES ENGINEER
 Address: THOMAS MEMORIAL HOSPITAL 4605 MacGraw Ave. SC. 25309
 Telephone Number: 304-766-3680
 Project Name: VARIOUS
 Project Description: BOILER & STEAM LINE REPAIRS

Carbon Steel Ball Valves

Two-Piece Bar Stock Body • Conventional Port •
Blowout-Proof Stem • 316 SS Trim • Vented Ball

2000 PSI/138 Bar Non-Shock Cold Working Pressure (1/4"-1")
1500 PSI/103 Bar Non Shock Cold Working Pressure (1 1/4"-2") ♦

CONFORMS TO MSS SP-110

MATERIAL LIST

| PART | SPECIFICATION |
|--------------------------|--|
| 1. Handle Nut | Carbon Steel ASTM A 283 |
| 2. Stem | Stainless Steel ASTM A 276 Type 316 |
| 3. Lock Washer | Carbon Steel |
| 4. Belleville Washer (2) | Carbon Steel ASTM A 686 |
| 5. Stem Packing (2) | Reinforced PTFE |
| 6. Thrust Washer | Carbon Filled PTFE |
| 7. Body End Piece | Carbon Steel ASTM A 108 Type 1018 |
| 8. Spacer Seal | PTFE |
| 9. Ball (Vented) | Stainless Steel ASTM A 276 Type 316 or ASTM A 351 Type CF8M |
| 10. Seat (2) | Reinforced PTFE |
| 11. Body | Carbon Steel ASTM A 108 Type 1018 |
| 12. Gland Washer | Stainless Steel ASTM A 240 Type 304 |
| 13. Handle | Carbon Steel ASTM A 283 |

1/4"-1" 2000 PSI CWP, 1 1/4"-2" 1500 PSI CWP.

NOTE: Valves are static grounded by thrust washer and packing.

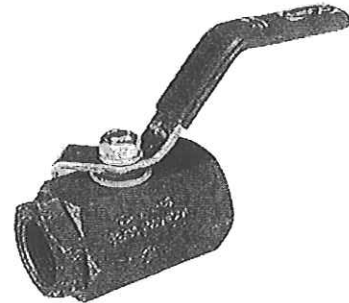

T-580-CS-R-66
Threaded

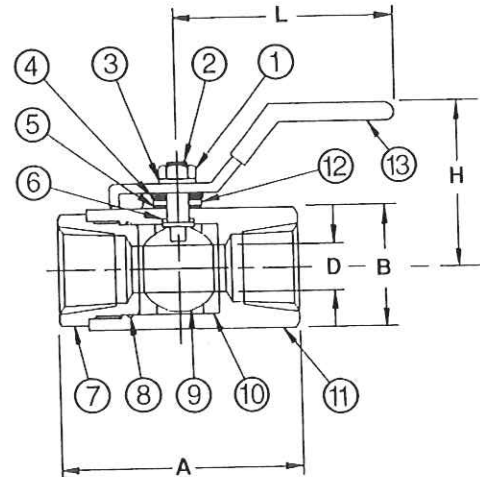

T-580-CS-R-66
NPT x NPT

DIMENSIONS—WEIGHTS—QUANTITIES

| Size | Dimensions | | | | | | T-580-CS-R-66 | Master |
|----------|------------|---------|---------|---------|----------|-----------|---------------|--------|
| | A | B | D | H | L | Ctn. Qty. | | |
| In. mm. | In. mm. | In. mm. | In. mm. | In. mm. | In. mm. | Lbs. Kg. | | |
| 1/4 8 | 2.30 58 | 1.02 26 | .38 10 | 2.22 56 | 4.13 105 | .59 27 | 10 | |
| 3/8 10 | 2.30 58 | 1.02 26 | .38 10 | 2.22 56 | 4.13 105 | .55 25 | 10 | |
| 1/2 15 | 2.52 64 | 1.26 32 | .50 10 | 2.44 62 | 4.17 105 | .79 36 | 10 | |
| 3/4 20 | 2.95 75 | 1.61 41 | .69 13 | 2.64 66 | 4.17 105 | 1.43 65 | 10 | |
| 1 25 | 3.35 85 | 1.97 50 | .89 18 | 2.83 72 | 5.83 148 | 2.40 1.08 | 10 | |
| 1 1/4 32 | 3.66 93 | 2.17 55 | 1.00 25 | 2.97 75 | 5.83 148 | 3.01 1.37 | 5 | |
| 1 1/2 40 | 4.11 104 | 2.64 67 | 1.25 32 | 3.25 83 | 7.00 182 | 4.80 2.20 | 5 | |
| 2 50 | 4.61 117 | 3.03 77 | 1.50 38 | 3.54 90 | 7.24 185 | 6.62 3.00 | 5 | |

♦ For detailed Operating Pressure, refer to Pressure Temperature Chart on pages 66 and 67.



State of West Virginia
DRUG FREE WORKPLACE CONFORMANCE AFFIDAVIT
West Virginia Code §21-1D-5

STATE OF WEST VIRGINIA

COUNTY OF KANAWHAH, TO-WIT:

I, Ronald L King, after being first duly sworn, depose and state as follows:

- 1. I am an employee of ELCO MECHANICAL CONTRACTORS; and,
(Company Name)
- 2. I do hereby attest that ELCO MECHANICAL CONTRACTORS
(Company Name)

maintains a valid written drug free workplace policy and that such policy is in compliance with **West Virginia Code §21-1D-5**.

The above statements are sworn to under the penalty of perjury.

ELCO MECHANICAL CONTRACTORS
(Company Name)

By: Ronald L King

Title: PROJECT MANAGER

Date: 1/23/12

Taken, subscribed and sworn to before me this 23RD day of JANUARY.

By Commission expires 3-30-2014

(Seal)  NOTARY PUBLIC OFFICIAL SEAL
 CHARLOTTE A. BOWLES
 State of West Virginia
 Elco Mechanical Contractors
 P.O. Box 349
 Charleston, WV 25322
 My Commission Expires Mar. 30, 2014

Charlotte A. Bowles
(Notary Public)

THIS AFFIDAVIT MUST BE SUBMITTED WITH THE BID IN ORDER TO COMPLY WITH WV CODE PROVISIONS. FAILURE TO INCLUDE THE AFFIDAVIT WITH THE BID SHALL RESULT IN DISQUALIFICATION OF THE BID.

Agency _____
REQ.P.O# _____

BID BOND

KNOW ALL MEN BY THESE PRESENTS, That we, the undersigned, _____
of _____, _____, as Principal, and _____
of _____, _____, a corporation organized and existing under the laws of the State of _____
with its principal office in the City of _____, as Surety, are held and firmly bound unto the State
of West Virginia, as Obligee, in the penal sum of _____ (\$ _____) for the payment of which,
well and truly to be made, we jointly and severally bind ourselves, our heirs, administrators, executors, successors and assigns.

The Condition of the above obligation is such that whereas the Principal has submitted to the Purchasing Section of the
Department of Administration a certain bid or proposal, attached hereto and made a part hereof, to enter into a contract in writing for

NOW THEREFORE,

- (a) If said bid shall be rejected, or
- (b) If said bid shall be accepted and the Principal shall enter into a contract in accordance with the bid or proposal attached
hereto and shall furnish any other bonds and insurance required by the bid or proposal, and shall in all other respects perform the
agreement created by the acceptance of said bid, then this obligation shall be null and void, otherwise this obligation shall remain in full
force and effect. It is expressly understood and agreed that the liability of the Surety for any and all claims hereunder shall, in no event,
exceed the penal amount of this obligation as herein stated.

The Surety, for the value received, hereby stipulates and agrees that the obligations of said Surety and its bond shall be in no
way impaired or affected by any extension of the time within which the Obligee may accept such bid, and said Surety does hereby
waive notice of any such extension.

IN WITNESS WHEREOF, Principal and Surety have hereunto set their hands and seals, and such of them as are corporations
have caused their corporate seals to be affixed hereunto and these presents to be signed by their proper officers, this
_____ day of _____, 20____.

Principal Corporate Seal

(Name of Principal)

By _____
(Must be President or
Vice President)

(Title)

Surety Corporate Seal

(Name of Surety)

Attorney-in-Fact

**IMPORTANT – Surety executing bonds must be licensed in West Virginia to transact surety insurance. Raised corporate seals
must be affixed, a power of attorney must be attached.**

BID BOND PREPARATION INSTRUCTIONS

AGENCY (A)
RFQ/RFP# (B)

Bid Bond

- (A) WV State Agency (Stated on Page 1 "Spending Unit") Request for Quotation Number (upper right corner of page #1)
(C) Your Company Name
(D) City, Location of your Company
(E) State, Location of your Company
(F) Surety Corporate Name
(G) City, Location of Surety
(H) State, Location of Surety
(I) State of Surety Incorporation
(J) City of Surety Incorporation
(K) Minimum amount of acceptable bid bond is 5% of total bid. You may state "5% of bid" or a specific amount on this line in words.
(L) Amount of bond in figures
(M) Brief Description of scope of work
(N) Day of the month
(O) Month
(P) Year
(Q) Name of Corporation
(R) Raised Corporate Seal of Principal
(S) Signature of President or Vice President
(T) Title of person signing
(U) Raised Corporate Seal of Surety
(V) Corporate Name of Surety
(W) Signature of Attorney in Fact of the Surety
NOTE: Dated, Power of Attorney with Raised Surety Seal must accompany this bid bond.

KNOW ALL MEN BY THESE PRESENTS, That we, the undersigned, (C) of (D), (E) as Principal, and (F) of (G), (H), a corporation organized and existing under the laws of the State of (I) with its principal office in the City of (J), as Surety, are held and firmly bound unto The State of West Virginia, as Obligee, in the penal sum of (K) (\$ (L)) for the payment of which, well and truly to be made, we jointly and severally bind ourselves, our heirs, administrators, executors, successors and assigns.

The Condition of the above obligation is such that whereas the Principal has submitted to the Purchasing Section of the Department of Administration a certain bid or proposal, attached hereto and made a part hereof to enter into a contract in writing for (M)

NOW THEREFORE.

(a) If said bid shall be rejected, or (b) If said bid shall be accepted and the Principal shall enter into a contract in accordance with the bid or proposal attached hereto and shall furnish any other bonds and insurance required by the bid or proposal, and shall in all other respects perform the agreement created by the acceptance of said bid then this obligation shall be null and void, otherwise this obligation shall remain in full force and effect. It is expressly understood and agreed that the liability of the Surety for any and all claims hereunder shall, in no event, exceed the penal amount of this obligation as herein stated

The Surety for value received, hereby stipulates and agrees that the obligations of said Surety and its bond shall be in no way impaired or affected by any extension of time within which the Obligee may accept such bid: and said Surety does hereby waive notice of any such extension.

IN WITNESS WHEREOF, Principal and Surety have hereunto set their hands and seals, and such of them as are corporations have caused their corporate seals to be affixed hereto and these presents to be signed by their proper officers, this (N) day of (O), 20 (P).

Principal Corporate Seal

(R)

(U) Surety Corporate Seal

(Q) (Name of Principal)

By (S) (Must be President or Vice President)

(T) Title

(V) (Name of Surety)

(W) Attorney-in-Fact

IMPORTANT - Surety executing bonds must be licensed in West Virginia to transact surety insurance. Raised Corporate Seals must be affixed and a Power of Attorney must be attached.

RFQ No. GSD126429

STATE OF WEST VIRGINIA
Purchasing Division

PURCHASING AFFIDAVIT

West Virginia Code §5A-3-10a states: No contract or renewal of any contract may be awarded by the state or any of its political subdivisions to any vendor or prospective vendor when the vendor or prospective vendor or a related party to the vendor or prospective vendor is a debtor and the debt owed is an amount greater than one thousand dollars in the aggregate.

DEFINITIONS:

"Debt" means any assessment, premium, penalty, fine, tax or other amount of money owed to the state or any of its political subdivisions because of a judgment, fine, permit violation, license assessment, defaulted workers' compensation premium, penalty or other assessment presently delinquent or due and required to be paid to the state or any of its political subdivisions, including any interest or additional penalties accrued thereon.

"Debtor" means any individual, corporation, partnership, association, limited liability company or any other form or business association owing a debt to the state or any of its political subdivisions. "Political subdivision" means any county commission; municipality; county board of education; any instrumentality established by a county or municipality; any separate corporation or instrumentality established by one or more counties or municipalities, as permitted by law; or any public body charged by law with the performance of a government function or whose jurisdiction is coextensive with one or more counties or municipalities. "Related party" means a party, whether an individual, corporation, partnership, association, limited liability company or any other form or business association or other entity whatsoever, related to any vendor by blood, marriage, ownership or contract through which the party has a relationship of ownership or other interest with the vendor so that the party will actually or by effect receive or control a portion of the benefit, profit or other consideration from performance of a vendor contract with the party receiving an amount that meets or exceeds five percent of the total contract amount.

EXCEPTION: The prohibition of this section does not apply where a vendor has contested any tax administered pursuant to chapter eleven of this code, workers' compensation premium, permit fee or environmental fee or assessment and the matter has not become final or where the vendor has entered into a payment plan or agreement and the vendor is not in default of any of the provisions of such plan or agreement.

Under penalty of law for false swearing (*West Virginia Code §61-5-3*), it is hereby certified that the vendor affirms and acknowledges the information in this affidavit and is in compliance with the requirements as stated.

WITNESS THE FOLLOWING SIGNATURE

Vendor's Name: ELCO MECHANICAL CONTRACTORS

Authorized Signature: *Ronald J. King* Date: 1/24/12

State of WEST VIRGINIA

County of KANAWHA, to-wit:

Taken, subscribed, and sworn to before me this 24TH day of JANUARY, 2012.

My Commission expires 3-30, 2014.

AFFIX SEAL HERE

NOTARY PUBLIC *Charlotte A. Bowls*

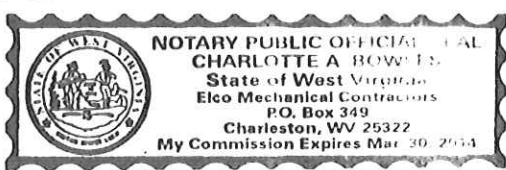



State of West Virginia
 Department of Administration
 Purchasing Division
 2019 Washington Street East
 Post Office Box 50130
 Charleston, WV 25305-0130

**request for
 Quotation**

RFQ NUMBER
 GSD126429

PAGE
 1

ADDRESS CORRESPONDENCE TO ATTENTION OF
 SHELLY MURRAY
 304-558-8801

*709043152 304-346-0546
 ELCO MECHANICAL CONTRACTORS
 PO BOX 349
 CHARLESTON WV 25322

DEPARTMENT OF ADMINISTRATION
 GENERAL SERVICES DIVISION
 BUILDING FIVE - HIGHWAYS
 1900 KANAWHA BOULEVARD, EAST
 CHARLESTON, WV
 25305 304-558-2317

| DATE PRINTED | TERMS OF SALE | SHIP VIA | F.O.B. | FREIGHT TERMS |
|--------------|---------------|----------|--------|---------------|
| 01/18/2012 | | | | |

BID OPENING DATE: 01/24/2012 BID OPENING TIME 01:30PM

| LINE | QUANTITY | UOP | CAT NO | ITEM NUMBER | UNIT PRICE | AMOUNT |
|--|----------|-----|--------|-------------|------------|--------|
| ADDENDUM NO. 1 | | | | | | |
| THIS ADDENDUM IS ISSUED TO: | | | | | | |
| 1.) PROVIDE A COPY OF THE MANDATORY PRE-BID ATTENDEE LIST, | | | | | | |
| 2.) PROVIDE ANSWERS TO ALL TECHNICAL QUESTIONS SUBMITTED IN ACCORDANCE WITH THE PROVISIONS OF THE ORIGINAL REQUEST FOR QUOTATION (GSD126429) | | | | | | |
| 3.) EXTEND THE BID OPENING DATE | | | | | | |
| BID OPENING DATE IS EXTENDED TO: 01/24/2012 | | | | | | |
| BID OPENING TIME REMAINS: 1:30 PM | | | | | | |
| ***** ADDENDUM NO. 1 ***** | | | | | | |
| 0001 | 1 | LS | | 031-13 | | |
| VALVE REPLACEMENTS, 11TH FLOOR BOILER ROOM BLDG 5 | | | | | | |

SEE REVERSE SIDE FOR TERMS AND CONDITIONS

| | | |
|-----------|-----------|-----------------------------------|
| SIGNATURE | TELEPHONE | DATE |
| TITLE | FEIN | ADDRESS CHANGES TO BE NOTED ABOVE |

WHEN RESPONDING TO RFQ, INSERT NAME AND ADDRESS IN SPACE ABOVE LABELED 'VENDOR'

GSD126429 Technical Questions, Answers and Clarifications

Q1. When valves are replaced on Boilers, Boilers would have to be drained. Is the contractor responsible for replenishing the Water Treatment or the Glycol?

A1. NO, The Agency has a water treatment contractor.

Q2. Does the valve replacement have to be done on the weekend?

A2. Work must be completed between Friday evening at 6 p.m. through Sunday at noon; not Monday through Friday as stated in RFQ.

Q3. Is contractor responsible for bringing Boilers back on line?

A3. NO, Agency staff will bring Boilers back on-line, however the contractor will be responsible for correcting leaks caused by retro fit.

Clarifications

GSD will perform the shutdown of the boilers prior to the contractor beginning work. This shall be coordinated through the Project Manager, Roger Wines.

All 4 boilers shall be shutdown at the same time.

Pipe insulation may be installed at any time after the valves have been installed.

The valves that are specified to be replaced in this RFQ are not for steam control, they are water control valves. Hot water is the only thing that passes through them.

PRE-BID CONFERENCE
SIGN IN SHEET

Request for Quotation Number: GSD120429 Date: 01/11/12

PLEASE PRINT LEGIBLY. THIS INFORMATION IS ESSENTIAL TO CONTACT THE ATTENDEES IN A TIMELY MANNER. FAILURE TO DO SO MAY RESULT IN DELAYS IN YOUR COMPANY GETTING IMPORTANT BID INFORMATION.

| | |
|---------------------------|--|
| Firm Name: | <u>Nitro Mechanical</u> |
| Firm Address: | <u>4300 Siest Avenue, Siest, West Virginia</u> |
| | <u>P.O. Box 879</u> |
| | <u>Nitro WV 25143-1001</u> |
| Representative Attending: | <u>Dusan Best</u> |
| Phone Number: | <u>304-964-0546</u> |
| Fax Number: | <u>304-204-1350</u> |
| Email Address: | <u>dbest@nitromechanical.com</u> |

| | |
|---------------------------|--------------------------------------|
| Firm Name: | <u>Elico Mechanical Contractors</u> |
| Firm Address: | <u>P.O. Box 349</u> |
| | <u>Charleston WV 25322</u> |
| Representative Attending: | <u>Ron King</u> |
| Phone Number: | <u>304-346-0546</u> |
| Fax Number: | <u>304-346-0548</u> |
| Email Address: | <u>RONALDKING@SUDDENLINKMAIL.COM</u> |

| | |
|---------------------------|-----------------------------|
| Firm Name: | <u>Comco Inc</u> |
| Firm Address: | <u>2336 Vorseman Ave</u> |
| | <u>Huntington, WV 25526</u> |
| Representative Attending: | <u>Lee Brown</u> |
| Phone Number: | <u>304 522-7705</u> |
| Fax Number: | <u>304 397-4978</u> |
| Email Address: | <u>lbrown@comco.wv.com</u> |

| | |
|---------------------------|-----------------------------------|
| Firm Name: | <u>Alpha Mechanical Serv</u> |
| Firm Address: | <u>401 27th St</u> |
| | <u>DUNBAR WV 25064</u> |
| Representative Attending: | <u>Michael Hatfield</u> |
| Phone Number: | <u>304 767-5610</u> |
| Fax Number: | <u>304 766-7008</u> |
| Email Address: | <u>RANDY.BAERWETZ@GAMSERV.COM</u> |

| | |
|---------------------------|---------------------------------|
| Firm Name: | <u>Casto Technical Service</u> |
| Firm Address: | <u>540 Lees Sullivan Way</u> |
| | <u>Charleston WV 25301</u> |
| Representative Attending: | <u>Paul Lancaster</u> |
| Phone Number: | <u>304-346-0549</u> |
| Fax Number: | <u>304-346-1723</u> |
| Email Address: | <u>plancaster@castotech.com</u> |

| | |
|---------------------------|------------------------------------|
| Firm Name: | <u>Sett Carr</u> |
| Firm Address: | <u>Carroll</u> |
| Representative Attending: | <u>Tim Ball</u> |
| Phone Number: | <u>304-741-2538</u> |
| Fax Number: | <u>860-998-9833</u> |
| Email Address: | <u>tim.ball@carrollcarroll.com</u> |

PRE-BID CONFERENCE
SIGN IN SHEET

Request for Quotation Number: 6SD1760429

Date: 01/11/12

PLEASE PRINT LEGIBLY. THIS INFORMATION IS ESSENTIAL TO CONTACT THE ATTENDEES IN A TIMELY MANNER. FAILURE TO DO SO MAY RESULT IN DELAYS IN YOUR COMPANY GETTING IMPORTANT BID INFORMATION.

| | |
|---------------------------|---|
| Firm Name: | <u>Carroll Corp</u> |
| Firm Address: | |
| Representative Attending: | <u>Ron Karpman</u> |
| Phone Number: | <u>304 595 5795</u> |
| Fax Number: | <u>860 998 9953</u> |
| Email Address: | <u>Ronald.F.Karpman@CarrollCorp.com</u> |

| | |
|---------------------------|--|
| Firm Name: | |
| Firm Address: | |
| Representative Attending: | |
| Phone Number: | |
| Fax Number: | |
| Email Address: | |

| | |
|---------------------------|--|
| Firm Name: | |
| Firm Address: | |
| Representative Attending: | |
| Phone Number: | |
| Fax Number: | |
| Email Address: | |

| | |
|---------------------------|--|
| Firm Name: | |
| Firm Address: | |
| Representative Attending: | |
| Phone Number: | |
| Fax Number: | |
| Email Address: | |

| | |
|---------------------------|--|
| Firm Name: | |
| Firm Address: | |
| Representative Attending: | |
| Phone Number: | |
| Fax Number: | |
| Email Address: | |

| | |
|---------------------------|--|
| Firm Name: | |
| Firm Address: | |
| Representative Attending: | |
| Phone Number: | |
| Fax Number: | |
| Email Address: | |

BID BOND

KNOW ALL MEN BY THESE PRESENTS, That we, the undersigned, Elco Mechanical Contractors, Inc.
of Charleston, WV, as Principal, and Fidelity and Deposit Company of Maryland
of Schaumburg, IL, a corporation organized and existing under the laws of the State of
MD with its principal office in the City of Schaumburg, as Surety, are held and firmly bound unto the State
of West Virginia, as Obligee, in the penal sum of Five Percent of Amount Bid (\$ 5%) for the payment of which,
well and truly to be made, we jointly and severally bind ourselves, our heirs, administrators, executors, successors and assigns.

The Condition of the above obligation is such that whereas the Principal has submitted to the Purchasing Section of the
Department of Administration a certain bid or proposal, attached hereto and made a part hereof, to enter into a contract in writing for
Valve Replacements, 11th floor boiler room, building 5

NOW THEREFORE,

(a) If said bid shall be rejected, or
(b) If said bid shall be accepted and the Principal shall enter into a contract in accordance with the bid or proposal attached
hereto and shall furnish any other bonds and insurance required by the bid or proposal, and shall in all other respects perform the
agreement created by the acceptance of said bid, then this obligation shall be null and void, otherwise this obligation shall remain in full
force and effect. It is expressly understood and agreed that the liability of the Surety for any and all claims hereunder shall, in no event,
exceed the penal amount of this obligation as herein stated.

The Surety, for the value received, hereby stipulates and agrees that the obligations of said Surety and its bond shall be in no
way impaired or affected by any extension of the time within which the Obligee may accept such bid, and said Surety does hereby
waive notice of any such extension.

IN WITNESS WHEREOF, Principal and Surety have hereunto set their hands and seals, and such of them as are corporations
have caused their corporate seals to be affixed hereunto and these presents to be signed by their proper officers, this
24th day of January, 2012.

Principal Corporate Seal

Elco Mechanical Contractors, Inc.
(Name of Principal)
By [Signature]
(Must be President or
Vice President)
MEMBER
(Title)

Surety Corporate Seal

Fidelity and Deposit Company of Maryland
(Name of Surety)
By: [Signature]
Pamela V. Lanham Attorney-in-Fact

IMPORTANT – Surety executing bonds must be licensed in West Virginia to transact surety insurance. Corporate seals must be affixed,
and a power of attorney must be attached.

Power of Attorney
FIDELITY AND DEPOSIT COMPANY OF MARYLAND

KNOW ALL MEN BY THESE PRESENTS: That the FIDELITY AND DEPOSIT COMPANY OF MARYLAND, a corporation of the State of Maryland, by FRANK E. MARTIN JR., Vice President, and GREGORY E. MURRAY, Assistant Secretary, in pursuance of authority granted by Article VI, Section 2, of the By-Laws of said Company, which are set forth on the reverse side hereof and are hereby certified to be in full force and effect on the date hereof, does hereby nominate, constitute and appoint **Andrew K. TEETER, Janis K. PEACOCK, Kimberly L. MILES, Douglas P. TAYLOR, Donna J. PRICE and Pamela V. LANHAM, all of Charleston, West Virginia.** EACH its true and lawful agent and Attorney-in-Fact, to make, execute, seal and deliver, for, and on its behalf as surety, and as its act and deed: **any and all bonds and undertakings**, and the execution of such bonds or undertakings in pursuance of these presents, shall be as binding upon said Company, as fully and amply, to all intents and purposes, as if they had been duly executed and acknowledged by the regularly elected officers of the Company at its office in Baltimore, Md., in their own proper persons. This power of attorney revokes that issued on behalf of Andrew K. TEETER, Janis K. PEACOCK, Kimberly L. MILES, Douglas P. TAYLOR, Donna J. PRICE, dated July 23, 2004.

The said Assistant Secretary does hereby certify that the extract set forth on the reverse side hereof is a true copy of Article VI, Section 2, of the By-Laws of said Company, and is now in force.

IN WITNESS WHEREOF, the said Vice-President and Assistant Secretary have hereunto subscribed their names and affixed the Corporate Seal of the said FIDELITY AND DEPOSIT COMPANY OF MARYLAND, this 11th day of November, A.D. 2004.

ATTEST:

FIDELITY AND DEPOSIT COMPANY OF MARYLAND



Gregory E. Murray

Frank E. Martin Jr.

By:

Gregory E. Murray Assistant Secretary

Frank E. Martin Jr.

Vice President

State of Maryland }
City of Baltimore } ss:

On this 11th day of November, A.D. 2004, before the subscriber, a Notary Public of the State of Maryland, duly commissioned and qualified, came FRANK E. MARTIN JR., Vice President, and GREGORY E. MURRAY, Assistant Secretary of the FIDELITY AND DEPOSIT COMPANY OF MARYLAND, to me personally known to be the individuals and officers described in and who executed the preceding instrument, and they each acknowledged the execution of the same, and being by me duly sworn, severally and each for himself deposed and saith, that they are the said officers of the Company aforesaid, and that the seal affixed to the preceding instrument is the Corporate Seal of said Company, and that the said Corporate Seal and their signatures as such officers were duly affixed and subscribed to the said instrument by the authority and direction of the said Corporation.

IN TESTIMONY WHEREOF, I have hereunto set my hand and affixed my Official Seal the day and year first above written.



Maria D. Adamski

Maria D. Adamski

Notary Public

My Commission Expires: July 8, 2011

EXTRACT FROM BY-LAWS OF FIDELITY AND DEPOSIT COMPANY OF MARYLAND

"Article VI, Section 2. The Chairman of the Board, or the President, or any Executive Vice-President, or any of the Senior Vice-Presidents or Vice-Presidents specially authorized so to do by the Board of Directors or by the Executive Committee, shall have power, by and with the concurrence of the Secretary or any one of the Assistant Secretaries, to appoint Resident Vice-Presidents, Assistant Vice-Presidents and Attorneys-in-Fact as the business of the Company may require, or to authorize any person or persons to execute on behalf of the Company any bonds, undertaking, recognizances, stipulations, policies, contracts, agreements, deeds, and releases and assignments of judgements, decrees, mortgages and instruments in the nature of mortgages,...and to affix the seal of the Company thereto."

CERTIFICATE

I, the undersigned, Assistant Secretary of the FIDELITY AND DEPOSIT COMPANY OF MARYLAND, do hereby certify that the foregoing Power of Attorney is still in full force and effect on the date of this certificate; and I do further certify that the Vice-President who executed the said Power of Attorney was one of the additional Vice-Presidents specially authorized by the Board of Directors to appoint any Attorney-in-Fact as provided in Article VI, Section 2, of the By-Laws of the FIDELITY AND DEPOSIT COMPANY OF MARYLAND.

This Power of Attorney and Certificate may be signed by facsimile under and by authority of the following resolution of the Board of Directors of the FIDELITY AND DEPOSIT COMPANY OF MARYLAND at a meeting duly called and held on the 10th day of May, 1990.

RESOLVED: "That the facsimile or mechanically reproduced seal of the company and facsimile or mechanically reproduced signature of any Vice-President, Secretary, or Assistant Secretary of the Company, whether made heretofore or hereafter, wherever appearing upon a certified copy of any power of attorney issued by the Company, shall be valid and binding upon the Company with the same force and effect as though manually affixed."

IN TESTIMONY WHEREOF, I have hereunto subscribed my name and affixed the corporate seal of the said Company,

this 24th day of January, 2012.



Assistant Secretary