

Scanned 3-2-12



State of West Virginia
 Department of Administration
 Purchasing Division
 2019 Washington Street East
 Post Office Box 50130
 Charleston, WV 25305-0130

Request for Quotation

RFQ NUMBER
 GSD126414

PAGE
 1

ADDRESS CORRESPONDENCE TO ATTENTION OF:
 KRISTA FERRELL
 304-558-2596

*709053330 304-632-1558
 DANHILL CONSTRUCTION COMPANY
 PO BOX 685

VENDOR

GAULEY BRIDGE WV 25085

SHIP TO

DEPARTMENT OF ADMINISTRATION
 GENERAL SERVICES DIVISION
 BUILDING THIRTY-TWO
 2699 PARK AVENUE
 HUNTINGTON, WV
 25704 304-558-3517

DATE PRINTED 01/25/2012	TERMS OF SALE	SHIP VIA	F.O.B.	FREIGHT TERMS
BID OPENING DATE: 03/01/2012		BID OPENING TIME 01:30PM		

LINE	QUANTITY	UOP	CAT. NO.	ITEM NUMBER	UNIT PRICE	AMOUNT
0001	1	LS		968-42		\$41,539 ⁰⁰
<p>HVAC CONTROL PROGRAM REPAIRS IN BUILDING 84 32</p> <p>REQUEST FOR QUOTATION (RFQ) CONSTRUCTION</p> <p>THE WEST VIRGINIA STATE PURCHASING DIVISION FOR THE AGENCY, THE WEST VIRGINIA DIVISION OF GENERAL SERVICES, IS SOLICITING BIDS TO PROVIDE THE AGENCY WITH ALL LABOR MATERIALS, SUPPLIES, AND EQUIPMENT TO PROVIDE DRAINAGE REPAIRS TO THE PARKING LOT IN BUILDING 32 LOCATED AT 2699 PARK AVENUE IN HUNTINGTON, WEST VIRGINIA PER THE ATTACHED SPECIFICATIONS.</p> <p>A MANDATORY PRE-BID WILL BE HELD ON 02/08/12 AT 1:00 PM AT THE AGENCY'S LOCATION AT 2699 PARK AVENUE IN HUNTINGTON, WEST VIRGINIA. ALL INTERESTED PARTIES ARE REQUIRED TO ATTEND THIS MEETING FAILURE TO ATTEND THE MANDATORY PRE-BID SHALL RESULT IN DISQUALIFICATION OF THE BID. NO ONE PERSON MAY REPRESENT MORE THAN ONE BIDDER.</p> <p>AN ATTENDANCE SHEET WILL BE MADE AVAILABLE FOR ALL POTENTIAL BIDDERS TO COMPLETE. THIS WILL SERVE AS THE OFFICIAL DOCUMENT VERIFYING ATTENDANCE AT THE MANDATORY PRE-BID. FAILURE TO PROVIDE YOUR COMPANY AND REPRESENTATIVE NAME ON THE ATTENDANCE SHEET WILL RESULT IN DISQUALIFICATION OF THE BID. THE STATE WILL NOT ACCEPT ANY OTHER DOCUMENTATION TO VERIFY ATTENDANCE. THE BIDDER IS RESPONSIBLE FOR ENSURING THEY HAVE</p>						

RECEIVED
 2012 MAR -1 PM 12:01
 WV PURCHASING DIVISION

SEE REVERSE SIDE FOR TERMS AND CONDITIONS			
SIGNATURE <i>Robert D. Hill</i>	TELEPHONE 1-304-0698251	DATE 03-01-12	
TITLE PRESIDENT	FEIN 55-0698251	ADDRESS CHANGES TO BE NOTED ABOVE	

WHEN RESPONDING TO RFQ, INSERT NAME AND ADDRESS IN SPACE ABOVE LABELED 'VENDOR'



State of West Virginia
 Department of Administration
 Purchasing Division
 2019 Washington Street East
 Post Office Box 50130
 Charleston, WV 25305-0130

Request for Quotation

RFQ NUMBER
GSD126414

PAGE
2

ADDRESS CORRESPONDENCE TO ATTENTION OF:
KRISTA FERRELL 304-558-2596

*709053330 304-632-1558
 DANHILL CONSTRUCTION COMPANY
 PO BOX 685
 GAULEY BRIDGE WV 25085

VENDOR

SHIP TO

DEPARTMENT OF ADMINISTRATION
 GENERAL SERVICES DIVISION
 BUILDING THIRTY-TWO
 2699 PARK AVENUE
 HUNTINGTON, WV
 25704 304-558-3517

DATE PRINTED	TERMS OF SALE	SHIP VIA	F.O.B.	FREIGHT TERMS
01/25/2012				

BID OPENING DATE: 03/01/2012 BID OPENING TIME 01:30PM

LINE	QUANTITY	UOP	CAT. NO.	ITEM NUMBER	UNIT PRICE	AMOUNT
<p>COMPLETED THE INFORMATION REQUIRED ON THE ATTENDANCE SHEET. THE PURCHASING DIVISION AND THE STATE AGENCY WILL NOT ASSUME ANY RESPONSIBILITY FOR A BIDDER-S FAILURE TO COMPLETE THE PRE-BID ATTENDANCE SHEET. IN ADDITION, WE REQUEST THAT ALL POTENTIAL BIDDERS INCLUDE THEIR E-MAIL ADDRESS AND FAX NUMBER.</p> <p>ALL POTENTIAL BIDDERS ARE REQUESTED TO ARRIVE PRIOR TO THE STARTING TIME FOR THE PRE-BID. BIDDERS WHO ARRIVE LATE, BUT PRIOR TO THE DISMISSAL OF THE TECHNICAL PORTION OF THE PRE-BID WILL BE PERMITTED TO SIGN IN. BIDDERS WHO ARRIVE AFTER CONCLUSION OF THE TECHNICAL PORTION OF THE PRE-BID, BUT DURING ANY SUBSEQUENT PART OF THE PRE-BID WILL NOT BE PERMITTED TO SIGN THE ATTENDANCE SHEET.</p> <p>TECHNICAL QUESTIONS CONCERNING THIS SOLICITATION MUST BE SUBMITTED IN WRITING TO KRISTA FERRELL IN THE WEST VIRGINIA STATE PURCHASING DIVISION VIA FAX AT 304-558-4115 OR VIA EMAIL AT KRISTA.S.FERRELL@WV.GOV.</p> <p>DEADLINE FOR ALL TECHNICAL QUESTIONS IS 02/16/2012 AT THE CLOSE OF BUSINESS.</p> <p>ANY TECHNICAL QUESTIONS RECEIVED WILL BE ANSWERED BY FORMAL WRITTEN ADDENDUM TO BE ISSUED BY THE PURCHASING DIVISION AFTER THE DEADLINE HAS LAPSED.</p> <p>VERBAL COMMUNICATION: ANY VERBAL COMMUNICATION BETWEEN THE VENDOR AND ANY STATE PERSONNEL IS NOT BINDING, INCLUDING THAT MADE AT THE MANDATORY PRE-BID MEETING. ONLY INFORMATION ISSUED IN WRITING AND ADDED TO THE RFQ SPECIFICATIONS BY AN OFFICIAL WRITTEN ADDENDUM BY PURCHASING IS BINDING.</p> <p>NO CONTACT BETWEEN THE VENDOR AND THE AGENCY IS</p>						
SEE REVERSE SIDE FOR TERMS AND CONDITIONS						

SIGNATURE	TELEPHONE	DATE
TITLE	FEIN	ADDRESS CHANGES TO BE NOTED ABOVE

WHEN RESPONDING TO RFQ, INSERT NAME AND ADDRESS IN SPACE ABOVE LABELED 'VENDOR'



State of West Virginia
 Department of Administration
 Purchasing Division
 2019 Washington Street East
 Post Office Box 50130
 Charleston, WV 25305-0130

Request for Quotation

RFQ NUMBER
GSD126414

PAGE
3

ADDRESS CORRESPONDENCE TO ATTENTION OF:
KRISTA FERRELL 304-558-2596

*709053330 304-632-1558
 DANHILL CONSTRUCTION COMPANY
 PO BOX 685

VENDOR

GAULEY BRIDGE WV 25085

DEPARTMENT OF ADMINISTRATION
 GENERAL SERVICES DIVISION
 BUILDING THIRTY-TWO
 2699 PARK AVENUE
 HUNTINGTON, WV
 25704 304-558-3517

SHIP TO

DATE PRINTED	TERMS OF SALE	SHIP VIA	F.O.B.	FREIGHT TERMS
01/25/2012				

BID OPENING DATE: 03/01/2012 BID OPENING TIME 01:30PM

LINE	QUANTITY	UOP	CAT NO.	ITEM NUMBER	UNIT PRICE	AMOUNT
<p>PERMITTED WITHOUT THE EXPRESS WRITTEN CONSENT OF THE STATE BUYER. VIOLATION MAY RESULT IN REJECTION OF THE BID. THE STATE BUYER LISTED ABOVE IS THE SOLE CONTACT FOR ANY AND ALL INQUIRIES AFTER THIS RFQ HAS BEEN RELEASED.</p> <p>ANY INDIVIDUAL SIGNING THIS BID IS CERTIFYING THAT: (1) HE OR SHE IS AUTHORIZED BY THE BIDDER TO EXECUTE THE BID OR ANY DOCUMENTS RELATED THERETO ON BEHALF OF THE BIDDER, (2) THAT HE OR SHE IS AUTHORIZED TO BIND THE BIDDER IN A CONTRACTUAL RELATIONSHIP, AND (3) THAT THE BIDDER HAS PROPERLY REGISTERED WITH ANY STATE AGENCIES THAT MAY REQUIRE REGISTRATION.</p> <p>EXHIBIT 5</p> <p>WEST VIRGINIA CODE 21-1D-5 PROVIDES THAT: ANY SOLICITATION FOR A PUBLIC IMPROVEMENT CONSTRUCTION CONTRACT REQUIRES EACH VENDOR THAT SUBMITS A BID FOR THE WORK TO SUBMIT AT THE SAME TIME AN AFFIDAVIT OF COMPLIANCE WITH THE BID. THE ENCLOSED DRUG-FREE WORKPLACE AFFIDAVIT MUST BE SIGNED AND SUBMITTED WITH THE BID AS EVIDENCE OF THE VENDOR'S COMPLIANCE WITH THE PROVISIONS OF ARTICLE 1D, CHAPTER 21 OF THE WEST VIRGINIA CODE. FAILURE TO SUBMIT THE SIGNED DRUG-FREE WORKPLACE AFFIDAVIT WITH THE BID SHALL RESULT IN DISQUALIFICATION OF SUCH BID.</p> <p>NOTICE TO PROCEED: THIS CONTRACT IS TO BE PERFORMED WITHIN (90) CALENDAR DAYS AFTER THE NOTICE TO PROCEED IS RECEIVED. THE AGENCY WILL ISSUE A WRITTEN NOTICE TO PROCEED TO THE SUCCESSFUL VENDORS.</p> <p>CANCELLATION: THE DIRECTOR OF PURCHASING RESERVES THE RIGHT TO CANCEL THIS CONTRACT IMMEDIATELY UPON WRITTEN NOTICE TO THE VENDOR IF THE MATERIALS OR WORKMANSHIP</p>						

SEE REVERSE SIDE FOR TERMS AND CONDITIONS

SIGNATURE	TELEPHONE	DATE
TITLE	FEIN	ADDRESS CHANGES TO BE NOTED ABOVE

WHEN RESPONDING TO RFQ, INSERT NAME AND ADDRESS IN SPACE ABOVE LABELED 'VENDOR'



State of West Virginia
 Department of Administration
 Purchasing Division
 2019 Washington Street East
 Post Office Box 50130
 Charleston, WV 25305-0130

Request for Quotation

RFQ NUMBER
GSD126414

PAGE
4

ADDRESS CORRESPONDENCE TO ATTENTION OF:
KRISTA FERRELL 304-558-2596

*709053330 304-632-1558
 DANHILL CONSTRUCTION COMPANY
 PO BOX 685

GAULEY BRIDGE WV 25085

DEPARTMENT OF ADMINISTRATION
 GENERAL SERVICES DIVISION
 BUILDING THIRTY-TWO
 2699 PARK AVENUE
 HUNTINGTON, WV
 25704 304-558-3517

VENDOR

SHIP TO

DATE PRINTED	TERMS OF SALE	SHIP VIA	F.O.B.	FREIGHT TERMS
01/25/2012				

BID OPENING DATE: 03/01/2012 BID OPENING TIME 01:30PM

LINE	QUANTITY	UOP	CAT. NO.	ITEM NUMBER	UNIT PRICE	AMOUNT
<p>SUPPLIED ARE OF AN INFERIOR QUALITY OR DO NOT CONFORM WITH THE SPECIFICATIONS OF THE BID AND CONTRACT HERE IN.</p> <p>WAGE RATES: THE CONTRACTOR OR SUBCONTRACTOR SHALL PAY THE HIGHER OF THE U.S. DEPARTMENT OF LABOR MINIMUM WAG RATES AS ESTABLISHED FOR CABELL COUNTY, PURSUANT TO WEST VIRGINIA CODE 21-5A, ET, SEQ. (PREVAILING WAGE RATES APPLY TO THIS PROJECT)</p> <p>ARBITRATION: ANY REFERENCES MADE TO ARBITRATION OR INTEREST FOR PAYMENTS DUE (EXCEPT FOR ANY INTEREST REQUIRED BY STATE LAW) CONTAINED IN THIS CONTRACT OR IN ANY AMERICAN INSTITUTE OF ARCHITECTS DOCUMENTS PERTAINING TO THIS CONTRACT ARE HEREBY DELETED.</p> <p>WORKERS' COMPENSATION: VENDOR IS REQUIRED TO PROVIDE A CERTIFICATE FROM WORKERS' COMPENSATION IF SUCCESSFUL</p> <p>ALL OF THE ITEMS CHECKED BELOW WILL BE A REQUIREMENT OF THIS CONTRACT:</p> <p>(XX) INSURANCE: SUCCESSFUL VENDOR SHALL FURNISH PROOF OF COMMERCIAL GENERAL LIABILITY INSURANCE PRIOR TO ISSUANCE OF CONTRACT. UNLESS OTHERWISE SPECIFIED IN THE BID DOCUMENTS, THE MINIMUM AMOUNT OF INSURANCE COVERAGE REQUIRED IS \$1,000,000.00.</p> <p>() BUILDERS RISK INSURANCE: SUCCESSFUL VENDOR SHALL FURNISH PROOF OF BUILDERS RISK - ALL RISK INSURANCE IN AN AMOUNT EQUAL TO 100% OF THE AMOUNT OF THE CONTRACT.</p> <p>(XX) BONDS: FIVE PERCENT (5%) OF THE TOTAL AMOUNT OF THE BID PAYABLE TO THE STATE OF WEST VIRGINIA, SHALL BE SUBMITTED WITH EACH BID AS A BID BOND. THE SUCCESSFUL BIDDER SHALL ALSO FURNISH A PERFORMANCE BOND AND LABOR</p>						

SEE REVERSE SIDE FOR TERMS AND CONDITIONS

SIGNATURE	TELEPHONE	DATE
TITLE	FEIN	ADDRESS CHANGES TO BE NOTED ABOVE

WHEN RESPONDING TO RFQ, INSERT NAME AND ADDRESS IN SPACE ABOVE LABELED 'VENDOR'



State of West Virginia
 Department of Administration
 Purchasing Division
 2019 Washington Street East
 Post Office Box 50130
 Charleston, WV 25305-0130

Request for Quotation

RFQ NUMBER
GSD126414

PAGE
5

ADDRESS CORRESPONDENCE TO ATTENTION OF:
KRISTA FERRELL 304-558-2596

VENDOR

*709053330 304-632-1558
 DANHILL CONSTRUCTION COMPANY
 PO BOX 685
 GAULEY BRIDGE WV 25085

SHIP TO

DEPARTMENT OF ADMINISTRATION
 GENERAL SERVICES DIVISION
 BUILDING THIRTY-TWO
 2699 PARK AVENUE
 HUNTINGTON, WV
 25704 304-558-3517

DATE PRINTED	TERMS OF SALE	SHIP VIA	F.O.B.	FREIGHT TERMS
01/25/2012				
BID OPENING DATE: 03/01/2012		BID OPENING TIME 01:30PM		

LINE	QUANTITY	UOP	CAT NO.	ITEM NUMBER	UNIT PRICE	AMOUNT
				<p>MATERIAL BOND FOR 100% OF THE AMOUNT OF THE CONTRACT. BONDS MAY BE PROVIDED IN THE FORM OF A CERTIFIED CHECK, IRREVOCABLE LETTER OF CREDIT, OR BOND FURNISHED BY A SOLVENT SURETY COMPANY AUTHORIZED TO DO BUSINESS IN THE STATE OF WEST VIRGINIA. A LETTER OF CREDIT SUBMITTED IN LIEU OF A BOND WILL ONLY BE ALLOWED FOR PROJECTS UNDER \$100,000. PERSONAL OR BUSINESS CHECKS ARE NOT ACCEPCTABLE IN LIEU OF THE 5% BID BOND, PERFORMANCE BOND, OR LABOR AND MATERIAL BOND.</p> <p>() MAINTENANCE BOND: A TWO (2) YEAR MAINTENANCE BOND COVERING THE ROOFING SYSTEM WILL BE A REQUIREMENT OF THE SUCCESSFUL VENDOR.</p> <p>REV. 11/00</p> <p>EXHIBIT 7</p> <p>DOMESTIC ALUMINUM, GLASS & STEEL IN PUBLIC WORKS PROJECTS</p> <p>IN ACCORDANCE WITH WEST VIRGINIA CODE 5-19-1 ET., SEQ., EVERY CONTRACT FOR CONSTRUCTION, RECONSTRUCTION, ALTERATION, REPAIR, IMPROVEMENT OR MAINTENANCE OF PUBLIC WORKS, WHERE THE COST IS MORE THAN \$50,000 AND, IN THE CASE OF STEEL ONLY, WHERE THE COST OF STEEL IS MORE THAN \$50,000 OR WHERE MORE THAN 10,000 POUNDS OF STEEL ARE REQUIRED, THE STATE WILL ACCEPT ONLY ALUMINUM GLASS, OR STEEL PRODUCTS PRODUCED IN THE UNITED STATES IN ADDITION, ITEMS OF MACHINERY OR EQUIPMENT PURCHASED FOR USE AT THE SITE OF PUBLIC WORKS SHALL BE MADE OF DOMESTIC ALUMINUM, GLASS OR STEEL, UNLESS THE COST OF THE PRODUCT IS LESS THAN \$50,000 OR LESS THAN 10,000 POUNDS OF STEEL ARE USED IN PUBLIC WORKS PROJECTS.</p>		

SEE REVERSE SIDE FOR TERMS AND CONDITIONS			
SIGNATURE	TELEPHONE	DATE	
TITLE	FEIN	ADDRESS CHANGES TO BE NOTED ABOVE	

WHEN RESPONDING TO RFQ, INSERT NAME AND ADDRESS IN SPACE ABOVE LABELED 'VENDOR'



State of West Virginia
 Department of Administration
 Purchasing Division
 2019 Washington Street East
 Post Office Box 50130
 Charleston, WV 25305-0130

Request for Quotation

RFQ NUMBER
GSD126414

PAGE
6

ADDRESS CORRESPONDENCE TO ATTENTION OF:
KRISTA FERRELL 304-558-2596

*709053330 304-632-1558
 DANHILL CONSTRUCTION COMPANY
 PO BOX 685

GAULEY BRIDGE WV 25085

DEPARTMENT OF ADMINISTRATION
 GENERAL SERVICES DIVISION
 BUILDING THIRTY-TWO
 2699 PARK AVENUE
 HUNTINGTON, WV
 25704 304-558-3517

VENDOR

SHIP TO

DATE PRINTED	TERMS OF SALE	SHIP VIA	F.O.B.	FREIGHT TERMS
01/25/2012				

BID OPENING DATE: 03/01/2012 BID OPENING TIME 01:30PM

LINE	QUANTITY	UOP	CAT. NO.	ITEM NUMBER	UNIT PRICE	AMOUNT
<p>FOREIGN MADE ALUMINUM, GLASS OR STEEL PRODUCTS MAY BE ACCEPTED ONLY IF THE COST OF DOMESTIC PRODUCTS IS FOUND TO BE UNREASONABLE. SUCH COST IS UNREASONABLE IF IT IS 20% OR MORE HIGHER THAN THE BID PRICE FOR FOREIGN MADE PRODUCTS. IF THE DOMESTIC ALUMINUM, GLASS OR STEEL PRODUCTS TO BE SUPPLIED OR PRODUCED IN A "SUBSTANTIAL LABOR SURPLUS AREA", AS DEFINED BY THE UNITED STATES DEPARTMENT OF LABOR, FOREIGN PRODUCTS MAY BE SUPPLIED ONLY IF DOMESTIC PRODUCTS ARE 30% OR MORE HIGHER IN PRICE THAN THE FOREIGN MADE PRODUCTS.</p> <p>IF, PRIOR TO THE AWARD OF A CONTRACT UNDER THE ABOVE PROVISIONS, THE SPENDING OFFICER OF THE SPENDING UNIT DETERMINES THAT THERE EXISTS A BID FOR LIKE FOREIGN ALUMINUM, GLASS OR STEEL THAT IS REASONABLE AND LOWER THAN THE LOWEST BID DOMESTIC PRODUCTS, THE SPENDING OFFICE MAY REQUEST, IN WRITING, A REEVALUATION AND REDUCTION IN THE LOWEST BID FOR SUCH DOMESTIC PRODUCTS ALL VENDORS MUST INDICATE IN THEIR BID IF THEY ARE SUPPLYING FOREIGN ALUMINUM, GLASS OR STEEL.</p> <p>REV. 3/88</p> <p>EXHIBIT 9</p> <p>NOTICE FOR ISSUANCE & ACKNOWLEDGEMENT OF CONSTRUCTION PROJECT ADDENDA</p> <p>THE ARCHITECT/ENGINEER AND/OR AGENCY SHALL BE REQUIRED TO ABIDE BY THE FOLLOWING SCHEDULE IN ISSUING CONSTRUCTION PROJECT ADDENDA FOR STATE AGENCIES:</p> <p>(1) THE ARCHITECT/ENGINEER SHALL PREPARE THE ADDENDUM AND A LIST OF ALL PARTIES THAT HAVE PROCURED DRAWINGS AND SPECIFICATIONS FOR THE PROJECT. THE ADDENDUM</p>						

SEE REVERSE SIDE FOR TERMS AND CONDITIONS

SIGNATURE	TELEPHONE	DATE
TITLE	FEIN	ADDRESS CHANGES TO BE NOTED ABOVE

WHEN RESPONDING TO RFQ, INSERT NAME AND ADDRESS IN SPACE ABOVE LABELED 'VENDOR'



State of West Virginia
 Department of Administration
 Purchasing Division
 2019 Washington Street East
 Post Office Box 50130
 Charleston, WV 25305-0130

Request for Quotation

RFQ NUMBER
GSD126414

PAGE
7

ADDRESS CORRESPONDENCE TO ATTENTION OF:
KRISTA FERRELL 304-558-2596

*709053330 304-632-1558

VENDOR

DANHILL CONSTRUCTION COMPANY
 PO BOX 685

GAULEY BRIDGE WV 25085

SHIP TO

DEPARTMENT OF ADMINISTRATION
 GENERAL SERVICES DIVISION
 BUILDING THIRTY-TWO
 2699 PARK AVENUE
 HUNTINGTON, WV
 25704 304-558-3517

DATE PRINTED	TERMS OF SALE	SHIP VIA	F.O.B.	FREIGHT TERMS
01/25/2012				

BID OPENING DATE: 03/01/2012 BID OPENING TIME 01:30PM

LINE	QUANTITY	UOP	CAT. NO.	ITEM NUMBER	UNIT PRICE	AMOUNT
<p>AND LIST SHALL BE FORWARDED TO THE BUYER IN THE STATE PURCHASING DIVISION. THE ARCHITECT/ENGINEER SHALL ALSO SEND A COPY OF THE ADDENDUM TO THE STATE AGENCY FOR WHICH THE CONTRACT IS ISSUED.</p> <p>(2) THE BUYER SHALL SEND THE ADDENDUM TO ALL INTERESTED PARTIES AND, IF NECESSARY, EXTEND THE BID OPENING DATE. ANY ADDENDUM SHOULD BE RECEIVED BY THE BUYER WITHIN FOURTEEN (14) DAYS PRIOR TO THE BID OPENING DATE.</p> <p>(3) ALL ADDENDA SHOULD BE FORMALLY ACKNOWLEDGED BY ALL BIDDERS AND SUBMITTED TO THE STATE PURCHASING DIVISION. THE SAME RULES AND REGULATIONS THAT APPLY TO THE ORIGINAL BIDDING DOCUMENT SHALL ALSO APPLY TO AN ADDENDUM DOCUMENT. THE ONLY EXCEPTION MAY BE FOR AN ADDENDUM THAT IS ISSUED FOR THE SOLE PURPOSE OF CHANGING A BID OPENING TIME AND/OR DATE.</p> <p>REV. 11/96</p> <p>EXHIBIT 10</p> <p>ADDENDUM ACKNOWLEDGEMENT</p> <p>I HEREBY ACKNOWLEDGE RECEIPT OF THE FOLLOWING CHECKED ADDENDUM(S) AND HAVE MADE THE NECESSARY REVISIONS TO MY PROPOSAL, PLANS AND/OR SPECIFICATION, ETC.</p> <p>ADDENDUM NOS.:</p> <p>NO. 1 02.06.12.....</p> <p>NO. 2 02.27.12.....</p>						

SEE REVERSE SIDE FOR TERMS AND CONDITIONS

SIGNATURE	TELEPHONE	DATE
TITLE	FEIN	ADDRESS CHANGES TO BE NOTED ABOVE

WHEN RESPONDING TO RFQ, INSERT NAME AND ADDRESS IN SPACE ABOVE LABELED 'VENDOR'



State of West Virginia
 Department of Administration
 Purchasing Division
 2019 Washington Street East
 Post Office Box 50130
 Charleston, WV 25305-0130

Request for Quotation

RFQ NUMBER
GSD126414

PAGE
8

ADDRESS CORRESPONDENCE TO ATTENTION OF:
KRISTA FERRELL
304-558-2596

VENDOR

*709053330 304-632-1558
 DANHILL CONSTRUCTION COMPANY
 PO BOX 685
 GAULEY BRIDGE WV 25085

SHIP TO

DEPARTMENT OF ADMINISTRATION
 GENERAL SERVICES DIVISION
 BUILDING THIRTY-TWO
 2699 PARK AVENUE
 HUNTINGTON, WV
 25704 304-558-3517

DATE PRINTED	TERMS OF SALE	SHIP VIA	F.O.B.	FREIGHT TERMS
01/25/2012				
BID OPENING DATE: 03/01/2012		BID OPENING TIME 01:30PM		

LINE	QUANTITY	UOP	CAT. NO.	ITEM NUMBER	UNIT PRICE	AMOUNT
NO. 3						
NO. 4						
NO. 5						
<p>I UNDERSTAND THAT FAILURE TO CONFIRM THE RECEIPT OF THE ADDENDUM(S) MAY BE CAUSE FOR REJECTION OF THE BIDS.</p> <p>VENDOR MUST CLEARLY UNDERSTAND THAT ANY VERBAL REPRESENTATION MADE OR ASSUMED TO BE MADE DURING ANY ORAL DISCUSSION HELD BETWEEN VENDOR'S REPRESENTATIVES AND ANY STATE PERSONNEL IS NOT BINDING. ONLY THE INFORMATION ISSUED IN WRITING AND ADDED TO THE SPECIFICATIONS BY AN OFFICIAL ADDENDUM IS BINDING.</p> <p>..... <i>Robert D. Hill</i>SIGNATURE</p> <p>..... <i>DANHILL CONSTRUCTION</i>COMPANY</p> <p>..... <i>03 01 12</i>DATE</p> <p>REV. 11/96</p> <p>CONTRACTORS LICENSE</p> <p>WEST VIRGINIA STATE CODE 21-11-2 REQUIRES THAT ALL PERSONS DESIRING TO PERFORM CONTRACTING WORK IN THIS STATE MUST BE LICENSED. THE WEST VIRGINIA CONTRACTORS LICENSING BOARD IS EMPOWERED TO ISSUE THE CONTRACTORS LICENSE. APPLICATIONS FOR A CONTRACTORS LICENSE MAY BE MADE BY CONTACTING THE WEST VIRGINIA DIVISION OF LABOR CAPITOL COMPLEX, BUILDING 3, ROOM 319, CHARLESTON, WV</p>						

SEE REVERSE SIDE FOR TERMS AND CONDITIONS			
SIGNATURE	TELEPHONE	DATE	
<i>Robert D. Hill</i>	1-304-632-1600	03-01-12	
TITLE	FEIN	ADDRESS CHANGES TO BE NOTED ABOVE	
<i>RESIDENT</i>	55-0648251		

WHEN RESPONDING TO RFQ, INSERT NAME AND ADDRESS IN SPACE ABOVE LABELED 'VENDOR'



State of West Virginia
 Department of Administration
 Purchasing Division
 2019 Washington Street East
 Post Office Box 50130
 Charleston, WV 25305-0130

Request for Quotation

RFQ NUMBER
GSD126414

PAGE
9

ADDRESS CORRESPONDENCE TO ATTENTION OF:
KRISTA FERRELL 304-558-2596

*709053330 304-632-1558
 DANHILL CONSTRUCTION COMPANY
 PO BOX 685

GAULEY BRIDGE WV 25085

DEPARTMENT OF ADMINISTRATION
 GENERAL SERVICES DIVISION
 BUILDING THIRTY-TWO
 2699 PARK AVENUE
 HUNTINGTON, WV
 25704 304-558-3517

DATE PRINTED	TERMS OF SALE	SHIP VIA	F.O.B.	FREIGHT TERMS
01/25/2012				

BID OPENING DATE: 03/01/2012 BID OPENING TIME 01:30PM

LINE	QUANTITY	UOP	CAT NO.	ITEM NUMBER	UNIT PRICE	AMOUNT
25305.				TELEPHONE: (304) 558-7890.		
WEST VIRGINIA STATE CODE 21-11-11 REQUIRES ANY PROSPECTIVE BIDDER TO INCLUDE THE CONTRACTORS LICENSE NUMBER ON THEIR BID. BIDDER TO COMPLETE: CONTRACTORS NAME: <i>DANHILL CONSTRUCTION</i> CONTRACTORS LICENSE NO.: <i>WV 001196</i> THE SUCCESSFUL BIDDER WILL BE REQUIRED TO FURNISH A COPY OF THEIR CONTRACTORS LICENSE PRIOR TO ISSUANCE OF A PURCHASE ORDER/CONTRACT APPLICABLE LAW THE WEST VIRGINIA STATE CODE, PURCHASING DIVISION RULES AND REGULATIONS, AND THE INFORMATION PROVIDED IN THE "REQUEST FOR QUOTATION" ISSUED BY THE PURCHASING DIVISION IS THE SOLE AUTHORITY GOVERNING THIS PROCUREMENT. ANY INFORMATION PROVIDED IN SPECIFICATION MANUALS, OR ANY OTHER SOURCE, VERBAL OR WRITTEN, WHICH CONTRADICTS OR ALTERS THE INFORMATION PROVIDED FROM THE SOURCES AS DESCRIBED IN THE ABOVE PARAGRAPH IS VOID AND OF NO EFFECT. BANKRUPTCY: IN THE EVENT THE VENDOR/CONTRACTOR FILES FOR BANKRUPTCY PROTECTION, THE STATE MAY DEEM THE CONTRACT NULL AND VOID, AND TERMINATE SUCH CONTRACT WITHOUT FURTHER ORDER. REV. 5/2009						

SEE REVERSE SIDE FOR TERMS AND CONDITIONS

SIGNATURE	<i>Robert D. Hill</i>	TELEPHONE	1-304-632-1600	DATE	03-01-12
TITLE	<i>RESIDENT</i>	FEIN	55-0648251	ADDRESS CHANGES TO BE NOTED ABOVE	

WHEN RESPONDING TO RFQ, INSERT NAME AND ADDRESS IN SPACE ABOVE LABELED 'VENDOR'



State of West Virginia
 Department of Administration
 Purchasing Division
 2019 Washington Street East
 Post Office Box 50130
 Charleston, WV 25305-0130

Request for Quotation

RFQ NUMBER
GSD126414

PAGE
10

ADDRESS CORRESPONDENCE TO ATTENTION OF:
KRISTA FERRELL
304-558-2596

*709053330 304-632-1558

DANHILL CONSTRUCTION COMPANY
 PO BOX 685

GAULEY BRIDGE WV 25085

VENDOR

SHIP TO

DEPARTMENT OF ADMINISTRATION
 GENERAL SERVICES DIVISION
 BUILDING THIRTY-TWO
 2699 PARK AVENUE
 HUNTINGTON, WV
 25704 304-558-3517

DATE PRINTED 01/25/2012	TERMS OF SALE	SHIP VIA	F.O.B.	FREIGHT TERMS
----------------------------	---------------	----------	--------	---------------

BID OPENING DATE: 03/01/2012 BID OPENING TIME 01:30PM

LINE	QUANTITY	UOP	CAT. NO.	ITEM NUMBER	UNIT PRICE	AMOUNT
<p>NOTICE</p> <p>A SIGNED BID MUST BE SUBMITTED TO:</p> <p>DEPARTMENT OF ADMINISTRATION PURCHASING DIVISION BUILDING 15 2019 WASHINGTON STREET, EAST CHARLESTON, WV 25305-0130</p> <p>THE BID SHOULD CONTAIN THIS INFORMATION ON THE FACE OF THE ENVELOPE OR THE BID MAY NOT BE CONSIDERED:</p> <p>SEALED BID</p> <p>BUYER: KRISTA FERRELL-FILE 21</p> <p>REQ. NO.: GSD126414</p> <p>BID OPENING DATE: 03/01/2012</p> <p>BID OPENING TIME: 1:30 PM</p> <p>PLEASE PROVIDE A FAX NUMBER IN CASE IT IS NECESSARY TO CONTACT YOU REGARDING YOUR BID:</p> <p style="text-align: center;">----- 1-304-632-1501 -----</p> <p>PLEASE PRINT OR TYPE NAME OF PERSON TO CONTACT CONCERNING THIS QUOTE:</p> <p style="text-align: center;">----- R. Dan Hill -----</p>						

SEE REVERSE SIDE FOR TERMS AND CONDITIONS

SIGNATURE <i>Robert D. Hill</i>	TELEPHONE 1-304-632-1600	DATE 03-01-12
TITLE PRESIDENT	FEIN 55-0648251	ADDRESS CHANGES TO BE NOTED ABOVE

WHEN RESPONDING TO RFQ, INSERT NAME AND ADDRESS IN SPACE ABOVE LABELED 'VENDOR'

State of West Virginia
General Services Division

Huntington State Office Building
Project No. GSD 126414
Site Drainage Repairs

Request for Quotations GSD126414
Huntington State Office Building, Bldg #32
Site Drainage Repairs
Huntington, WV

Location: Huntington State Office Building, Building #32
2699 Park Avenue
Huntington, West Virginia 25704

For: State of West Virginia
General Services Division
1900 Kanawha Blvd; East
Charleston, West Virginia 25305

All inquiries for specification clarification shall be addressed to:

Krista Ferrell, Buyer Supervisor
Purchasing Division
P. O. Box 50130
Charleston, West Virginia 25305-0130
Telephone: (304) 558-2596
Fax: (304) 558-4115
Krista.S.Ferrell@wv.gov

The Department of Administration, General Services Division, is soliciting quotations for all labor, materials and associated costs to provide and install drainage lines in the parking area on the south side of the State Office Building in Huntington, WV. This document is intended to supplement information provided in the standard "Request for Quotation" and "General Terms and Conditions" issued by the Purchasing Division for this project. Contractors should carefully review all documents.

Mandatory Pre-Bid Meeting:

A mandatory pre-bid conference will be held on **February 8, 2012** at 10:00 am. Contractors attending the meeting shall assemble in the lobby of Building 32 at 2699 Park Avenue, Huntington, WV 25704. See Purchasing Division Request for Quotation for additional information.

Scope of Work:

This RFQ includes furnishing all labor, materials, equipment, excavation, transportation and shop drawings necessary for the addition of drainage piping, gravel drainage and repaving in

State of West Virginia
General Services Division

Huntington State Office Building
Project No. GSD 126414
Site Drainage Repairs

the parking areas. The piping shall be installed to comply with all applicable standards and applicable state and local codes. Project area is the south parking area of the Huntington State Office Building as noted on the plan. Successful Bidder will be given ninety (90) calendar days from the written notice to proceed to complete the project.

The successful contractor shall be required to keep the work area clean on a daily basis and remove debris/waste materials from the site daily. Contractor will provide for the removal of all debris/waste materials from the work area and dispose of such materials in accordance with all governing regulations at an off-site location to be determined by the Contractor. All applicable local safety and OSHA rules / guidelines shall be met by the contractor. Contractor will furnish all materials, labor, and equipment necessary to complete all work for the installation of the drainage system. The selection of the materials used to execute this work will be in accordance with the attached and herein referenced project specifications and project specific drawings. Any other material selections not specified herein will be made by the Contractor only after prior written approval of General Services Division's Project Manager or designee.

Contractor will be solely responsible for any/all fees incurred by Contractor to satisfactorily complete the work described herein to the satisfaction of the General Services Division's Architecture / Engineering Manager or designee.

Contractor shall submit shop drawings consisting of material cut sheets for materials to be installed and details for submission to the Architecture / Engineering Section.

Furnish all materials, labor, and equipment necessary to complete all work cutting existing pavement, installing pipe and gravel bedding and repaving disturbed areas as indicated by these specifications. The completed work consists of the installation of drainage systems in the locations described herein attached to this RFQ. Furnish any incidental work, materials, labor and equipment that are necessary to complete the work, even if such incidental work is not explicitly included in the contract documents.

Any equipment contracted for prior to issuance of the signed purchase order and written Notice to Proceed letter shall be at the Bidder's risk.

Documents:

This Request for Quotations also incorporates the attached documents:

1. The WV Purchasing Division "Request for Quotation" and "General Terms and Conditions".
2. Attachment A: Bid Form
3. Drawings: A-1 Site Plan

State of West Virginia
General Services Division

Huntington State Office Building
Project No. GSD 126414
Site Drainage Repairs

Contract Period:

The Contract shall be completed within **ninety (90)** calendar days from the issuance of the written Notice to Proceed. Scheduled work may not begin until successful vendor has received a signed purchase order and Notice to Proceed letter. In accordance with the West Virginia State Code 5A-3-4(8), Contractor agrees that liquidated damages shall be imposed at the rate of \$100.00 per day for failure to complete the project within the contract period.

This clause shall in no way be considered exclusive and shall not limit the State or Agency's right to pursue any other additional remedy to which the State or Agency may have legal cause for action including further damages against the Contractor.

Definitions:

- A. "Agency", as herein stated, shall mean The Department of Administration, General Services Division.
- B. "Contractor", as herein stated, shall mean the vendor or service organization contracted by these specifications.
- C. "The Contract", as herein stated, shall mean the agreement between the Owner and the Contractor to provide the services as herein specified.
- D. "Agency Representative", as herein stated, shall be defined as that person so designated by the Director of the General Services Division.
- E. "Architect/Engineer", as herein stated in these Contract Documents shall refer to the General Services Division.

Payment:

Contractor shall submit monthly invoices on AIA Document G702 and G703. Deliver invoice to:

General Services Division
Attn: Business Manager
1900 Kanawha Blvd. East
Building 1, Room MB-68
Charleston, West Virginia 25305

All work shall be inspected and approved prior to payment. Contractor shall submit certified payrolls with the invoice.

General Conditions:

1. The Contractor shall procure all necessary permits and licenses to comply with all applicable laws, Federal, State, or municipal, along with all regulations, and ordinances of any regulating body.

State of West Virginia
General Services Division

Huntington State Office Building
Project No. GSD 126414
Site Drainage Repairs

2. The Contractor shall pay any applicable sales, use, or personal property taxes, arising out of this Contract and the transactions contemplated thereby. Any other taxes levied upon this Contract, the transaction, or the equipment, or services delivered pursuant hereto shall be borne by the Contractor. It is clearly understood that the State of West Virginia is exempt from any taxes regarding performance of the scope of work of this Contract.

3. Contractor shall be responsible for parts and materials as follows:

- a) The Contractor shall supply all tools, tool accessories, personal safety equipment and supplies necessary to execute the responsibilities of this Contract.
- b) Contractor shall furnish a warranty of twelve (12) months from date of substantial completion for labor and materials, in addition to individual material warranties,

Bonds and Insurance:

Refer to Purchasing Division's 'Request for Quotation' for requirements on bonding; insurance; wage rates; "Foreign made aluminum, glass and steel in Public Works Projects", and other project requirements.

Final Inspection:

The final inspection will be conducted by a Project Manager from the General Services Division, Architectural / Engineering Section.

Work found to be in accordance with the Contract Documents will be accepted as complete for final acceptance. Unacceptable work, or work not in accordance with the Contract Documents shall be removed, replaced, changed or cleaned as required to meet requirements of Contract Documents prior to final acceptance. Final acceptance does not waive or release Contractor to conform to the Contract Documents.

Final payment shall not be made until all work is finally accepted.

Limits of Work

Work areas will be limited to those areas designated on the attached site plan. Some exterior space may be utilized for temporary storage of equipment and tools. Coordinate storage needs with the Project Manager.

Agency facilities shall remain in use during this contract. Contractor shall work with the Building Manager and Protective Services to coordinate the temporary access to work areas and otherwise provide for the Contractor needs to complete work. Contractor shall minimize disruption to work areas and parking lot access.

State of West Virginia
General Services Division

Huntington State Office Building
Project No. GSD 126414
Site Drainage Repairs

Use of Facilities

Contractor shall be permitted reasonable use of building utilities including power, water and sanitary sewage disposal as required for conducting the work. Coordinate the location of service connections or use of receptacle with the building manager to avoid overloading existing circuits.

Contractor Schedule:

Provide overall project schedule within seventy-two hours of Notice to Proceed. Provide a proposed construction schedule indicating areas to be worked. Where coordination or disruption of occupants may be required, provide at least one week's advance notice prior to conducting work in those areas. Adhere to schedule provided and coordinate with through Project Manager. Work schedules will be reviewed and approved by the General Services Division's Project Manager. Contractor will be afforded access as required to complete work on schedule.

Work Restrictions:

Typically work may be conducted during normal business hours between 7:00 am and 5:00 pm, Monday through Friday, except State-recognized holidays. To minimize disruptions to parking areas, work may be permitted on evenings, weekend and state holidays with prior approval of the Project Manager.

Waste Removal

Contractor shall make arrangements for the collection and disposal of Contractor's waste and construction related debris. Debris shall be removed on a daily basis.

Contractor Visitor Badges

The State Office Building is a semi-secure facility. Prior to beginning work, Contractor shall provide a list of all personnel working on this project. This list shall include a copy of a valid driver's license or other legal identification and include date of birth. All proposed workers may be subjected to a criminal history / driver's license background check prior to being permitted to work in state buildings. Workers shall carry valid Contractor Photo ID Badges to be worn when working around the building. Under no circumstances shall a worker be assigned to this project without the validation first being submitted to the General Services Division and approval given.

Parking

Limited parking is available on the project site. Coordinate parking needs with the Project Manager. Parking in non-designated areas is not permitted. A limited number of spaces will be allocated for contractors vehicles near the project site. Provisions will be made for locating

State of West Virginia
General Services Division

Huntington State Office Building
Project No. GSD 126414
Site Drainage Repairs

refuse dumpsters or storage if required by the project.

Use of loading dock areas for parking is strictly prohibited.

With prior approval, contractor's vehicles may be brought on-site for loading & unloading or to provide equipment necessary for conducting the work.

Codes:

All work is to be performed in compliance with applicable Federal and State codes including but not limited to the International Building Code, International Mechanical Code, Life Safety Code, NEC, OSHA, UL, ANSI, ASME, NFPA 13 and related standards.

Safety:

Perform all work in compliance with applicable safety regulations. Work shall be subject to verification and inspection by Agency Safety representatives. Such verification shall not relieve the Contractor from meeting all applicable safety regulations and inspection by other agencies.

Notify Agency if suspected hazardous materials are encountered. Any areas requiring abatement will be provided by the Agency under a separate contract.

Hot Work Permit:

All work will be performed outdoors so a HOT WORK PERMIT should not be required.

Contractor shall obtain Agency's permission prior to performing any work that requires an open flame, creates sparks, use's equipment that creates combustible temperatures, or performs any work that could result in a fire hazard. Agency will review work area and issue permission prior to Contractor commencing work. Note that the Contractor shall take proper precautions and may be required to provide a Fire Watch as a condition of the permit.

Workmanship:

Contractor shall complete all work in a neat and workmanlike manner. All work shall be done using new materials in a manner that meets commercial quality standards. Work shall be neat, true, plumb and square, as applicable. Contractor shall verify all dimensions.

State of West Virginia
Department of Administration

General Services Division
GSD126414 Bldg 32
Parking Lot Drain Repairs

GSD126414 Bid Form

Bidder's Company Name: DANHILL CONSTRUCTION

Bidder's Address: PO Box 685
GADLEY BRIDGE, WV 25085

Remittance Address: _____
(if different)

Phone Number: 1-304-632-1600

Fax Number: 1-304-632-1501

Email Address: RDANHILL@HOTMAIL.COM

WV Contractor's License Number: WV001196

We, the undersigned, having examined the site and being familiar with the local conditions affecting the cost of the work and also being familiar with the general conditions to bidders, drawings, and specifications, hereby propose to furnish all materials, equipment, and labor to complete all work in a workmanlike manner, as described in the Bidding Documents.

TOTAL CONTRACT BID (Total to be written in words and numbers)

Forty One Thousand Five Hundred Thirty Nine Dollars
(\$ 41,539⁰⁰)



State of West Virginia
DRUG FREE WORKPLACE CONFORMANCE AFFIDAVIT
West Virginia Code §21-1D-5

STATE OF West Virginia

COUNTY OF Fayette, TO-WIT:

I, Robert D. Hill, after being first duly sworn, depose and state as follows:

- 1. I am an employee of Danhill Construction Co.; and,
(Company Name)
- 2. I do hereby attest that Danhill construction Co
(Company Name)

maintains a valid written drug free workplace policy and that such policy is in compliance with **West Virginia Code** §21-1D-5.

The above statements are sworn to under the penalty of perjury.

Danhill Construction Co.
(Company Name)

By: Robert D. Hill

Title: President

Date: 3/1/12

Taken, subscribed and sworn to before me this 1 day of March 12.

By Commission expires 3/28/2015

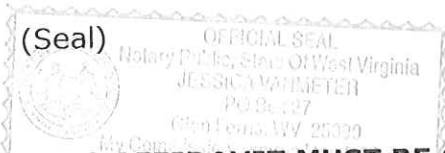

Jessica Whitmer
(Notary Public)

THIS AFFIDAVIT MUST BE SUBMITTED WITH THE BID IN ORDER TO COMPLY WITH WV CODE PROVISIONS. FAILURE TO INCLUDE THE AFFIDAVIT WITH THE BID SHALL RESULT IN DISQUALIFICATION OF THE BID.

STATE OF WEST VIRGINIA
Purchasing Division

PURCHASING AFFIDAVIT

West Virginia Code §5A-3-10a states: No contract or renewal of any contract may be awarded by the state or any of its political subdivisions to any vendor or prospective vendor when the vendor or prospective vendor or a related party to the vendor or prospective vendor is a debtor and the debt owed is an amount greater than one thousand dollars in the aggregate.

DEFINITIONS:

"Debt" means any assessment, premium, penalty, fine, tax or other amount of money owed to the state or any of its political subdivisions because of a judgment, fine, permit violation, license assessment, defaulted workers' compensation premium, penalty or other assessment presently delinquent or due and required to be paid to the state or any of its political subdivisions, including any interest or additional penalties accrued thereon.

"Debtor" means any individual, corporation, partnership, association, limited liability company or any other form or business association owing a debt to the state or any of its political subdivisions. "Political subdivision" means any county commission; municipality; county board of education; any instrumentality established by a county or municipality; any separate corporation or instrumentality established by one or more counties or municipalities, as permitted by law; or any public body charged by law with the performance of a government function or whose jurisdiction is coextensive with one or more counties or municipalities. "Related party" means a party, whether an individual, corporation, partnership, association, limited liability company or any other form or business association or other entity whatsoever, related to any vendor by blood, marriage, ownership or contract through which the party has a relationship of ownership or other interest with the vendor so that the party will actually or by effect receive or control a portion of the benefit, profit or other consideration from performance of a vendor contract with the party receiving an amount that meets or exceed five percent of the total contract amount.

EXCEPTION: The prohibition of this section does not apply where a vendor has contested any tax administered pursuant to chapter eleven of this code, workers' compensation premium, permit fee or environmental fee or assessment and the matter has not become final or where the vendor has entered into a payment plan or agreement and the vendor is not in default of any of the provisions of such plan or agreement.

Under penalty of law for false swearing (*West Virginia Code §61-5-3*), it is hereby certified that the vendor affirms and acknowledges the information in this affidavit and is in compliance with the requirements as stated.

WITNESS THE FOLLOWING SIGNATURE

Vendor's Name: Dankhill Construction Company

Authorized Signature: Robert D. Hill Date: 3/1/12

State of West Virginia

County of Payette, to-wit:

Taken, subscribed, and sworn to before me this 1 day of March, 2012.

My Commission expires March 28, 2015

AFFIX SEAL HERE

NOTARY PUBLIC Jessica V. Smith

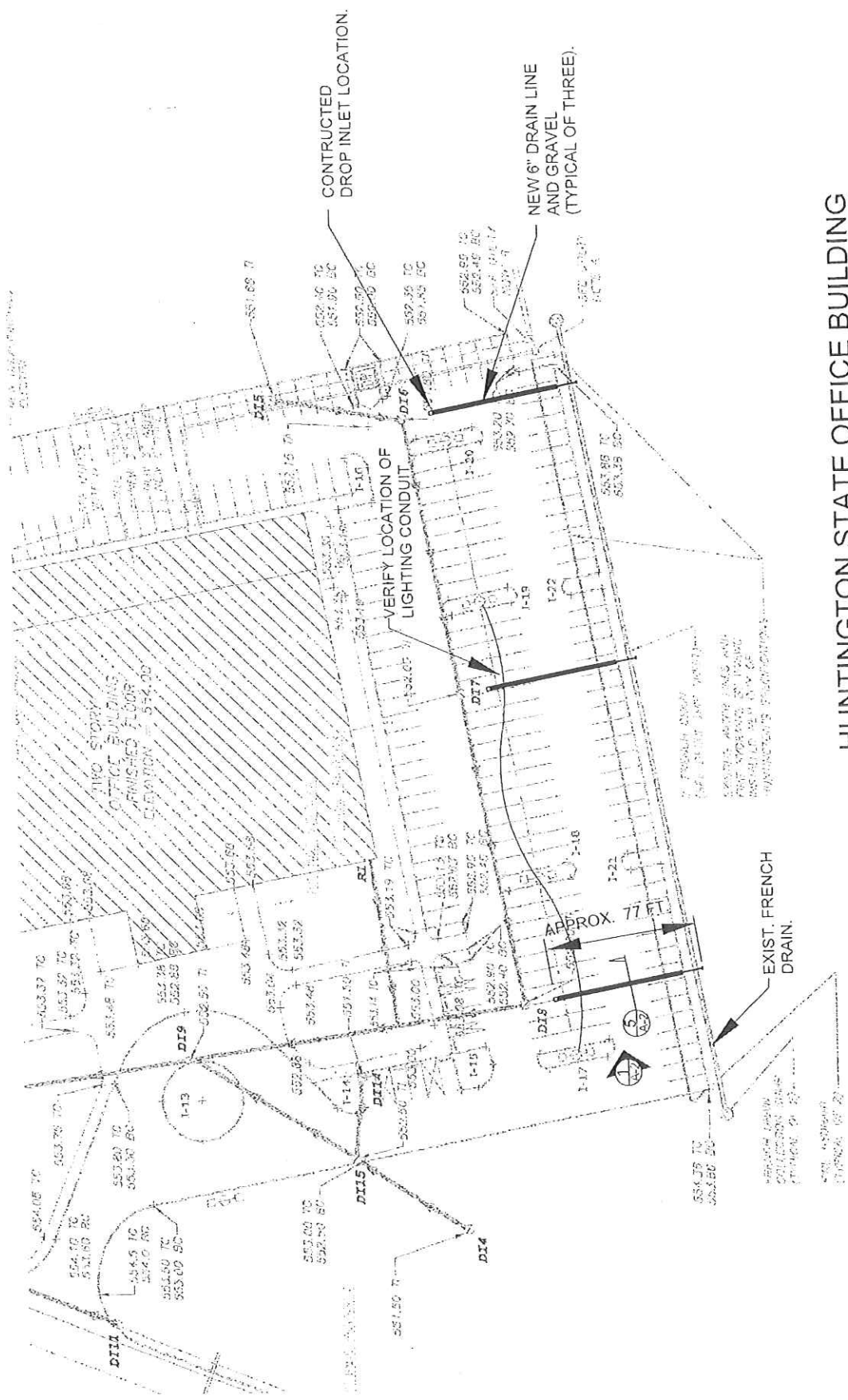

**HUNTINGTON STATE OFFICE BUILDING
A-1 SITE PLAN**



Attachment B: Drawing A-1 Site Plan



State of West Virginia
 Department of Administration
 Purchasing Division
 2019 Washington Street East
 Post Office Box 50130
 Charleston, WV 25305-0130

Request for Quotation

RFP NUMBER
GSD126414

PAGE
1

ADDRESS CORRESPONDENCE TO ATTENTION OF
**KRISTA FERRELL
 304-558-2596**

DAN HILL

*709053330 304-632-1558
DANHILL CONSTRUCTION COMPANY
 PO BOX 685
GAULEY BRIDGE WV 25085

DAN HILL

**DEPARTMENT OF ADMINISTRATION
 GENERAL SERVICES DIVISION
 BUILDING THIRTY-TWO
 2699 PARK AVENUE
 HUNTINGTON, WV
 25704 304-558-3517**

DATE PRINTED	TERMS OF SALE	SHIP VIA	FOB	FREIGHT TERMS
02/06/2012				

BID OPENING DATE: **03/01/2012** BID OPENING TIME: **01:30PM**

LINE	QUANTITY	UOP	CAT NO.	ITEM NUMBER	UNIT PRICE	AMOUNT
ADDENDUM NO. 1						
THIS ADDENDUM IS ISSUED TO:						
1.) TO CLARIFY THE SCOPE OF THE PROJECT. THIS PROJECT TO PROVIDE DRAINAGE REPAIRS TO THE PARKING LOT IN BUILDING 32 LOCATED AT 2699 PARK AVENUE IN HUNTINGTON, WEST VIRGINIA. PLEASE DELETE ALL REFERENCE TO HVAC CONTROL PROGRAM REPAIRS IN BUILDING 84.						
2.) TO CLARIFY THE DATE, TIME, AND LOCATION OF THE MANDATORY PRE-BID MEETING						
THE MANDATORY PRE-BID MEETING SHALL BE HELD AT 1:00 PM AT THE AGENCY'S LOCATION AT 2699 PARK AVENUE IN HUNTINGTON, WEST VIRGINIA ON FEBRUARY 8, 2012.						
BID OPENING DATE REMAINS: 03/01/2012						
BID OPENING TIME REMAINS: 1:30 PM						
***** END ADDENDUM NO. 1 *****						
0001	1	LS		968-42		41,539.00
DRAINAGE REPAIRS TO PARKING LOT BLDG. 32						

SEE REVERSE SIDE FOR TERMS AND CONDITIONS

SIGNATURE <i>Robert D. Hill</i>	TELEPHONE 1-304-632-1600	DATE 03-01-12
TITLE PRESIDENT	FEIN 55-0648251	ADDRESS CHANGES TO BE NOTED ABOVE



State of West Virginia
 Department of Administration
 Purchasing Division
 2019 Washington Street East
 Post Office Box 50130
 Charleston, WV 25305-0130

Request for Quotation

RFQ NUMBER
GSD126414

PAGE
2

ADDRESS CORRESPONDENCE TO ATTENTION OF
**KRISTA FERRELL
 304-558-2596**

SUBJECT

*709053330 304-632-1558
**DANHILL CONSTRUCTION COMPANY
 PO BOX 685**

GAULEY BRIDGE WV 25085

SHIP TO

**DEPARTMENT OF ADMINISTRATION
 GENERAL SERVICES DIVISION
 BUILDING THIRTY-TWO
 2699 PARK AVENUE
 HUNTINGTON, WV
 25704 304-558-3517**

DATE PRINTED	TERMS OF SALE	SHIP VIA	FOB	FREIGHT TERMS
02/06/2012				
BID OPENING DATE: 03/01/2012		BID OPENING TIME 01:30PM		

LINE	QUANTITY	UOP	GAT NO	ITEM NUMBER	UNIT PRICE	AMOUNT
***** THIS IS THE END OF RFQ GSD126414 ***** TOTAL: _____						

SEE REVERSE SIDE FOR TERMS AND CONDITIONS

SIGNATURE <i>Robert D. Hill</i>	TELEPHONE 1-304-632-1600	DATE 03-01-12
TITLE PRESIDENT	FEIN 55-0648251	ADDRESS CHANGES TO BE NOTED ABOVE



State of West Virginia
 Department of Administration
 Purchasing Division
 2019 Washington Street East
 Post Office Box 50130
 Charleston, WV 25305-0130

Request for Quotation

RFQ NUMBER	GSD126414	PAGE	1
------------	-----------	------	---

ADDRESS CORRESPONDENCE TO ATTENTION OF
 KRISTA FERRELL
 304-558-2596

*709053330 304-632-1558
 DANHILL CONSTRUCTION COMPANY
 PO BOX 685
 GAULEY BRIDGE WV 25085

DEPARTMENT OF ADMINISTRATION
 GENERAL SERVICES DIVISION
 BUILDING THIRTY-TWO
 2699 PARK AVENUE
 HUNTINGTON, WV 25704 304-558-3517

DATE PRINTED	TERMS OF SALE	SHIP VIA	F.O.B.	FREIGHT TERMS
02/27/2012				
BID OPENING DATE: 03/01/2012		BID OPENING TIME 01:30PM		

LINE	QUANTITY	UQP	CAT NO	ITEM NUMBER	UNIT PRICE	AMOUNT
ADDENDUM NO. 2						
THIS ADDENDUM IS ISSUED TO:						
1.) PROVIDE A COPY OF THE MANDATORY PRE-BID ATTENDEE LIST,						
2.) PROVIDE ANSWERS TO ALL TECHNICAL QUESTIONS SUBMITTED IN ACCORDANCE WITH THE PROVISIONS OF THE ORIGINAL RFQ (GSD126414), AND						
3.) PROVIDE A-2 DETAIL DRAWING						
BID OPENING DATE REMAINS: 03/01/2012						
BID OPENING TIME REMAINS: 1:30 PM						
***** END ADDENDUM NO. 2 *****						
001	1	LS		968-42		\$41,539 ⁰⁰
DRAINAGE REPAIRS TO PARKING LOT BLDG. 32						

SEE REVERSE SIDE FOR TERMS AND CONDITIONS

SIGNATURE	TELEPHONE	DATE
<i>Robert D. Hill</i>	1-304-632-1600	03-01-12
TITLE	FEIN	ADDRESS CHANGES TO BE NOTED ABOVE
RESIDENT	55-0648251	

WHEN RESPONDING TO RFQ, INSERT NAME AND ADDRESS IN SPACE ABOVE LABELED 'VENDOR'

GENERAL TERMS & CONDITIONS REQUEST FOR QUOTATION (RFQ) AND REQUEST FOR PROPOSAL (RFP)

1. Awards will be made in the best interest of the State of West Virginia.
 2. The State may accept or reject in part, or in whole, any bid.
 3. Prior to any award, the apparent successful vendor must be properly registered with the Purchasing Division and have paid the required \$125 fee.
 4. All services performed or goods delivered under State Purchase Order/Contracts are to be continued for the term of the Purchase Order/Contracts, contingent upon funds being appropriated by the Legislature or otherwise being made available. In the event funds are not appropriated or otherwise available for these services or goods this Purchase Order/Contract becomes void and of no effect after June 30.
 5. Payment may only be made after the delivery and acceptance of goods or services.
 6. Interest may be paid for late payment in accordance with the *West Virginia Code*.
 7. Vendor preference will be granted upon written request in accordance with the *West Virginia Code*.
 8. The State of West Virginia is exempt from federal and state taxes and will not pay or reimburse such taxes.
 9. The Director of Purchasing may cancel any Purchase Order/Contract upon 30 days written notice to the seller.
 10. The laws of the State of West Virginia and the *Legislative Rules* of the Purchasing Division shall govern the purchasing process.
 11. Any reference to automatic renewal is hereby deleted. The Contract may be renewed only upon mutual written agreement of the parties.
 12. **BANKRUPTCY:** In the event the vendor/contractor files for bankruptcy protection, the State may deem this contract null and void, and terminate such contract without further order.
 13. **HIPAA BUSINESS ASSOCIATE ADDENDUM:** The West Virginia State Government HIPAA Business Associate Addendum (BAA), approved by the Attorney General, is available online at www.state.wv.us/admin/purchase/vrc/hipaa.html and is hereby made part of the agreement provided that the Agency meets the definition of a Cover Entity (45 CFR §160.103) and will be disclosing Protected Health Information (45 CFR §160.103) to the vendor.
 14. **CONFIDENTIALITY:** The vendor agrees that he or she will not disclose to anyone, directly or indirectly, any such personally identifiable information or other confidential information gained from the agency, unless the individual who is the subject of the information consents to the disclosure in writing or the disclosure is made pursuant to the agency's policies, procedures, and rules. Vendor further agrees to comply with the Confidentiality Policies and Information Security Accountability Requirements, set forth in <http://www.state.wv.us/admin/purchase/privacy/noticeConfidentiality.pdf>.
 15. **LICENSING:** Vendors must be licensed and in good standing in accordance with any and all state and local laws and requirements by any state or local agency of West Virginia, including, but not limited to, the West Virginia Secretary of State's Office, the West Virginia Tax Department, and the West Virginia Insurance Commission. The vendor must provide all necessary releases to obtain information to enable the director or spending unit to verify that the vendor is licensed and in good standing with the above entities.
 16. **ANTITRUST:** In submitting a bid to any agency for the State of West Virginia, the bidder offers and agrees that if the bid is accepted the bidder will convey, sell, assign or transfer to the State of West Virginia all rights, title and interest in and to all causes of action it may now or hereafter acquire under the antitrust laws of the United States and the State of West Virginia for price fixing and/or unreasonable restraints of trade relating to the particular commodities or services purchased or acquired by the State of West Virginia. Such assignment shall be made and become effective at the time the purchasing agency tenders the initial payment to the bidder.
- I certify that this bid is made without prior understanding, agreement, or connection with any corporation, firm, limited liability company, partnership, or person or entity submitting a bid for the same material, supplies, equipment or services and is in all respects fair and without collusion or fraud. I further certify that I am authorized to sign the certification on behalf of the bidder or this bid.

INSTRUCTIONS TO BIDDERS

1. Use the quotation forms provided by the Purchasing Division. Complete all sections of the quotation form.
2. Items offered must be in compliance with the specifications. Any deviation from the specifications must be clearly indicated by the bidder. Alternates offered by the bidder as **EQUAL** to the specifications must be clearly defined. A bidder offering an alternate should attach complete specifications and literature to the bid. The Purchasing Division may waive minor deviations to specifications.
3. Unit prices shall prevail in case of discrepancy. All quotations are considered F.O.B. destination unless alternate shipping terms are clearly identified in the quotation.
4. All quotations must be delivered by the bidder to the office listed below prior to the date and time of the bid opening. Failure of the bidder to deliver the quotations on time will result in bid disqualifications: Department of Administration, Purchasing Division, 2019 Washington Street East, P.O. Box 50130, Charleston, WV 25305-0130
5. Communication during the solicitation, bid, evaluation or award periods, except through the Purchasing Division, is strictly prohibited (W.Va. C.S.R. §148-1-6.6).

PRE-BID CONFERENCE
SIGN IN SHEET

Request for Quotation Number: 609120414

Date: 2/8/2012

PLEASE PRINT LEGIBLY. THIS INFORMATION IS ESSENTIAL TO CONTACT THE ATTENDEES IN A TIMELY MANNER. FAILURE TO DO SO MAY RESULT IN DELAYS IN YOUR COMPANY GETTING IMPORTANT BID INFORMATION.

Firm Name:	<u>WV Dept of Admin - BID</u>
Firm Address:	
Representative Attending:	<u>Bob Blackbird, Peter Palmer, Scott Paszky,</u>
Phone Number:	<u>Bob Knapp, Ted Payne</u>
Fax Number:	
Email Address:	

Firm Name:	<u>Gl Stone Inc</u>
Firm Address:	<u>24 First St</u> <u>Hamlin WV 25523</u>
Representative Attending:	<u>Allen Stone</u>
Phone Number:	<u>304 824 3800</u>
Fax Number:	<u>304 824 3848</u>
Email Address:	

Firm Name:	<u>MIKE SIEMIACZKO</u>
Firm Address:	<u>DAN HILL CONSTRUCTION</u> <u>PO Box 685</u> <u>GAULEY BRIDGE, WV</u>
Representative Attending:	<u>MIKE SIEMIACZKO</u>
Phone Number:	<u>304 632 1600</u>
Fax Number:	<u>304 632 1501</u>
Email Address:	<u>R.DANHILL@HITMAN.COM</u>

Firm Name:	<u>L+L Contracting</u>
Firm Address:	<u>7451 WV HWY 5E</u> <u>BUNNELLVILLE, WV 26335</u>
Representative Attending:	<u>Rick LeMaster</u>
Phone Number:	<u>304-991-1614</u>
Fax Number:	<u>304 295-5592</u>
Email Address:	<u>lemaster_rick@yahoo.com</u>

Firm Name:	<u>Pearl Gate Construction</u>
Firm Address:	<u>7 Anchor Way</u> <u>Winfield, WV 25312</u>
Representative Attending:	<u>Craig Brown</u>
Phone Number:	<u>304 597 8999</u>
Fax Number:	<u>304 755 4885</u>
Email Address:	<u>Cbrown10@yahoo.com</u>

Firm Name:	<u>CAPITOL VALLEY CONTRACTING</u>
Firm Address:	<u>67 RENEE DRIVE</u> <u>BEVIEW, WV 25071</u>
Representative Attending:	<u>Mickey Farmer</u>
Phone Number:	<u>304 437-4505</u>
Fax Number:	<u>304 965-2223</u>
Email Address:	<u>Mickey@CapitolValley.com</u>

PRE-BID CONFERENCE
SIGN IN SHEET

Request for Quotation Number: 8110444

Date: 2/6/2012

PLEASE PRINT LEGIBLY. THIS INFORMATION IS ESSENTIAL TO CONTACT THE ATTENDEES IN A TIMELY MANNER. FAILURE TO DO SO MAY RESULT IN DELAYS IN YOUR COMPANY GETTING IMPORTANT BID INFORMATION.

Firm Name:	<u>S.M.H. Construction Co.</u>
Firm Address:	<u>P.O. Box 1912 Bechtel, WV 25802</u>
Representative Attending:	<u>Mark Williams</u>
Phone Number:	<u>304-877-6451</u>
Fax Number:	<u>304-877-5789</u>
Email Address:	<u>MarkBL18@yahoo.com</u>

Firm Name:	
Firm Address:	
Representative Attending:	
Phone Number:	
Fax Number:	
Email Address:	

Firm Name:	<u>MJG Construction</u>
Firm Address:	
Representative Attending:	<u>Mar J Florick</u>
Phone Number:	<u>304-272-7891</u>
Fax Number:	<u>304-791-8176</u>
Email Address:	<u>Mirc.estimator@chesco.net</u>

Firm Name:	
Firm Address:	
Representative Attending:	
Phone Number:	
Fax Number:	
Email Address:	

Firm Name:	
Firm Address:	
Representative Attending:	
Phone Number:	
Fax Number:	
Email Address:	

Firm Name:	
Firm Address:	
Representative Attending:	
Phone Number:	
Fax Number:	
Email Address:	

State of West Virginia
General Services Division

Huntington State Office Building
Project No. GSD 126414
Site Drainage Repairs

Request for Quotations GSD126414
Huntington State Office Building, Bldg #32
Site Drainage Repairs
Huntington, WV

Technical Questions & Answers

Question #1: Would you have any detailed specifications on the parking lot repair job. We are looking for inlet details, drain line specifications, filter fabric required, parking blocks required, and any other specifications you may have.

Answer #1: Addendum #1 incorporates a drawing (GSD126414 A-2 Detail Drawing) that provides these specifications.

Question #2: What is the minimum thickness the #57 limestone should be under and over the 6" drain pipe?
Answer #2: The gravel fill shall be a minimum of 6" above and below the pipe. Gravel on the sides of the pipe should also have enough clearance to properly bed (work gravel under) the pipe and support the sides.

Question #3: What type of material is acceptable for the compacted fill? With the exception of the existing asphalt that is removed can we use the dirt/gravel that we dig up for fill material?

Answer #3: The fill has to be a suitable compactable material. If the dirt being removed from the trench is sufficiently dry and compactable, this should be adequate.

Question #4: What is the minimum width of the drainage ditches that are to be dug for the 6" drain pipe?

Answer #4: The minimum width should be about 16" to 18", however the width should also be wide enough to safely work and place pipe.

Material Specifications:

Concrete: Provide mix with 3,000 psi minimum strength concrete. 4" maximum slump

Asphalt: WV DOH 'Standard Specifications for Roads and Bridges', Section 401 Wearing Mix. Install in accordance with DOH Section 401.

Pipe: SDR 35 PVC pipe with drain holes as shown on drawings.

Backfill Material: Clean compactable fill material. May reuse excavated material if sufficiently dry to be compacted to 95% proctor.

Testing: Contractor to provide compaction testing of backfill to 95% proctor. Two tests required, locations chosen by Project Manager.

State of West Virginia
General Services Division

Huntington State Office Building
Project No. GSD 126414
Site Drainage Repairs

Other:

Remove asphalt paving, excess dirt and non-compactable fill material from site. Contractor shall be responsible for disposal of all waste materials.

Owner will provide use of traffic cones for marking off parking area. Coordinate with Project Manager and Building Maintenance Supervisor.

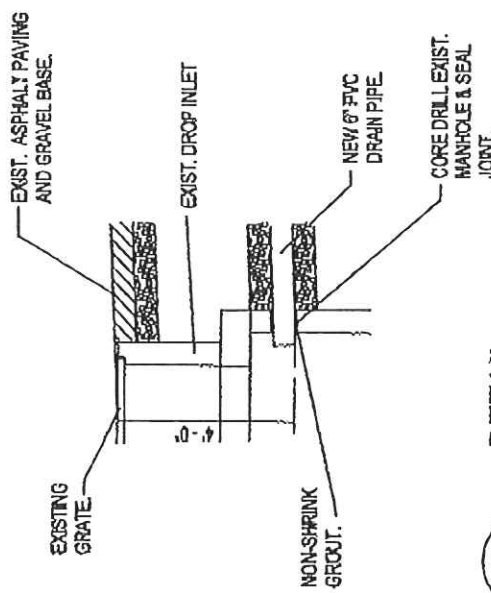

2 DETAIL

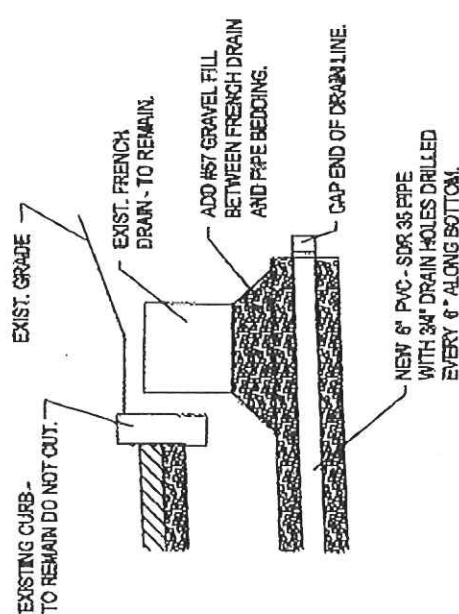

3 DETAIL

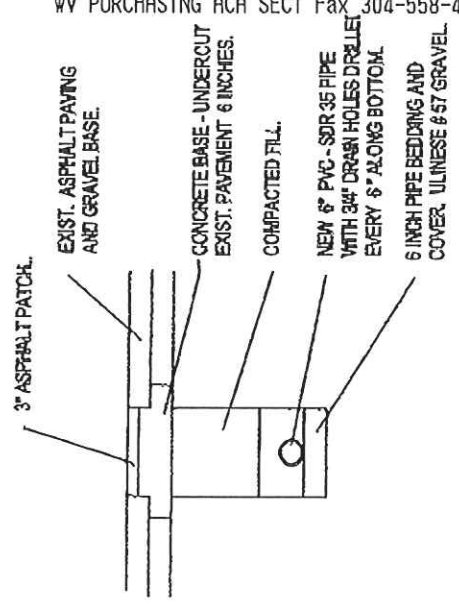

4 DETAIL

BID BOND

KNOW ALL MEN BY THESE PRESENTS, That we, the undersigned, Danhill Construction Company
of Gauley Bridge, West Virginia, as Principal, and Colonial Surety Co. of
Montvale, New Jersey, a corporation organized and existing under the laws of the State of NJ with its
principal office in the City of Montvale, as Surety, are held and firmly bound unto the State of West Virginia, as Obligee, in the
penal sum of 5 % Of Bid Amount (\$ 5%) for the payment of which, well and truly to be made, we jointly and
severally bind ourselves, our heirs, administrators, executors, successors and assigns.

The Condition of the above obligation is such that whereas the Principal has submitted to the Purchasing Section of the
Department of Administration a certain bid or proposal, attached hereto and made a part hereof, to enter into a contract in writing for
Install 3 each, 6 inch drainage lines in South Parking Lot at Bldg. 32

NOW THEREFORE,

(a) If said bid shall be rejected, or
(b) If said bid shall be accepted and the Principal shall enter into a contract in accordance with the bid or proposal attached
hereto and shall furnish any other bonds and insurance required by the bid or proposal, and shall in all other respects perform the
agreement created by the acceptance of said bid, then this obligation shall be null and void, otherwise this obligation shall remain in full
force and effect. It is expressly understood and agreed that the liability of the Surety for any and all claims hereunder shall, in no event,
exceed the penal amount of this obligation as herein stated.

The Surety, for the value received, hereby stipulates and agrees that the obligations of said Surety and its bond shall be in no
way impaired or affected by any extension of the time within which the Obligee may accept such bid, and said Surety does hereby
waive notice of any such extension.

IN WITNESS WHEREOF, Principal and Surety have hereunto set their hands and seals, and such of them as are corporations
have caused their corporate seals to be affixed hereunto and these presents to be signed by their proper officers, this

1st day of March, 20 12.

Principal Corporate Seal

Danhill Construction Company
(Name of Principal)

By Robert D. Hill *Robert D. Hill*
(Must be President or
Vice President)

President
(Title)

Surety Corporate Seal

Colonial Surety company
(Name of Surety)

Roberta Bird *Roberta Bird*
Attorney-in-Fact

**IMPORTANT - Surety executing bonds must be licensed in West Virginia to transact surety insurance. Raised corporate seals
must be affixed, a power of attorney must be attached.**

COLONIAL SURETY COMPANY

Duncannon, Pennsylvania
Administrative Office: 50 Chestnut Ridge Road, Montvale, New Jersey 07645

GENERAL POWER OF ATTORNEY

Know all Men by These Presents, That COLONIAL SURETY COMPANY, a corporation duly organized and existing under the laws of the Commonwealth of Pennsylvania and having an administrative office in Montvale, Bergen County, NJ does by these presents make, constitute and appoint

Wayne Nunziata or Anthony J. Cimasko or Audie B. Murphy

of Montvale and the State of New Jersey its true and lawful Attorney(s)-in-Fact, with full power and authority hereby conferred in its name, place and stead, to execute, acknowledge and deliver.

Any and All Bonds

and to bind the Company thereby as fully and to the same extent as if such bonds were signed by the President, sealed with the corporate seal of the Company and duly attested by its Secretary, hereby ratifying and confirming all that the said Attorney(s)-in-Fact may do in the premises.

Be it Resolved, that the President, any Vice-President, any Secretary or any Assistant Secretary shall be and is hereby vested with full power and authority to appoint any one or more suitable persons as Attorney(s)-in-Fact to represent and act for and on behalf of the Company subject to the following provisions:

Section I. Attorney-in-Fact. Attorney-in-Fact may be given full power and authority for and in the name of and on behalf of the Company, to execute, acknowledge and deliver, any and all bonds, recognizances, contracts, agreements of indemnity and other conditional or obligatory undertakings and any and all notices and documents canceling or terminating the Company's liability thereunder, and any such instruments so executed by any such Attorney-in-Fact shall be binding upon the Company as if signed by the President and sealed and attested by the Corporate Secretary.

In Witness Whereof, Colonial Surety Company has caused these presents to be signed by its President and its corporate seal to be hereto affixed the 27th day of April, A.D., 2011.

State of New Jersey
County of Bergen
SS.:



COLONIAL SURETY COMPANY

By Wayne Nunziata, President

On this 27th day of April, in the year 2011, before me Theresa Spinelli, a notary public, personally appeared Wayne Nunziata, personally known to me to be the person who executed the within instrument as President, on behalf of the corporation therein named and acknowledged to me that the corporation executed it.



THERESA SPINELLI
A Notary Public of New Jersey
My Commission Expires September 9, 2015

Theresa Spinelli, Notary Public

I, the undersigned Secretary of Colonial Surety Company, hereby certify that the above and foregoing is a full, true and correct copy of the Original Power of Attorney issued by said Company, and do hereby further certify that the said Power of Attorney is still in force and effect.

And I do hereby further certify that the Certification of this Power of Attorney is signed and sealed by facsimile under and by the authority of the following resolution adopted by the Board of Directors of the Colonial Surety Company at a meeting duly called and held on the 30th of January 1988, and that said resolution has not been amended or repealed:

RESOLVED, that the signature of the Secretary or any Assistant Secretary of this Corporation, and the seal of Corporation, may be affixed or printed by facsimile to any certificate to a Power of Attorney of this Corporation, and that such printed facsimile signature and seal shall be valid and binding upon this Corporation.

GIVEN under my hand and the seal of said Company, at Montvale, New Jersey this 1st day of March, 2012.

Original printed with Blue and Black ink. For verification of the authenticity of this Power of Attorney you may call (201) 573-8788 and ask for the Power of Attorney clerk. Please refer to the above named individual(s) and details of the bond to which the power is attached.

Audie B. Murphy, Secretary

State of West Virginia
County of Fayette

AND NOW, this 1st day of March, in the calendar year of 2012, before me, a duly appointed and commissioned notary public, came the identified subscriber to the within instrument or instruments, and/or the demonstrated attorney-in-fact for said signatory and subscriber on said instrument or instruments, **Roberta Bird, attorney-in-fact of Colonial Surety Company**, an insurance company duly organized and existing under the laws of the Commonwealth of Pennsylvania and which is authorized to conduct business in this State, and that as such being authorized to do so, acknowledged that the within instrument or instruments were executed as the authorized act of his disclosed principal for the purposes therein contained, and declared to be a person executing said instrument or instruments as attorney-in-fact and with full capacity and competency, at the request of and on behalf of Colonial Surety Company therein named and acknowledged to me that the aforesaid Colonial Surety Company had authorized the execution by the aforesaid attorney-in-fact of said instrument or instruments with the intent to be legally bound as required by common and statutory law.

IN WITNESS WHEREOF, I hereunto set my hand and official seal.

A Notary Public of West Virginia
My Commission Expires on 3/28/2015

Notary Public in and for the

County of Fayette
State of West Virginia

Jessica VanMeter
NOTARY PUBLIC



