



State of West Virginia
 Department of Administration
 Purchasing Division
 2019 Washington Street East
 Post Office Box 50130
 Charleston, WV 25305-0130

Request for Quotation

RFQ NUMBER
AGR1225

PAGE
1

ADDRESS CORRESPONDENCE TO ATTENTION OF:
FRANK WHITTAKER 304-558-2316

VENDOR

*709053227 304-453-6154
 MCCOY FREIGHTLINER INC
 PO BOX 438
 KENOVA WV 25530-0438

SHIP TO

DEPARTMENT OF AGRICULTURE
 FOOD DISTRIBUTION PROGRAM
 1 CEDAR LAKES DRIVE
 RIPLEY, WV 25271 304-558-2221

DATE PRINTED	TERMS OF SALE	SHIP VIA	F.O.B.	FREIGHT TERMS
03/18/2012				
BID OPENING DATE: 04/18/2012		BID OPENING TIME 01:30PM		

LINE	QUANTITY	UOP	CAT. NO.	ITEM NUMBER	UNIT PRICE	AMOUNT
0001	1	EA		070-45	\$97,770.00	\$97,770.00
<p>TRUCK TRACTORS</p> <p>THE WEST VIRGINIA PURCHASING DIVISION, FOR THE AGENCY THE WEST VIRGINIA DEPARTMENT OF AGRICULTURE IS SOLICITING BIDS FOR ONE (1) 2012 OR NEWER CLASS 8 DAY CAB TANDEM TRACTOR PER THE ATTACHED SPECIFICATIONS.</p> <p>ALL TECHNICAL QUESTIONS MUST BE SUBMITTED IN WRITING TO FRANK WHITTAKER IN THE WV PURCHASING DIVISION VIA EMAIL AT FRANK.M.WHITTAKER@WV.GOV OR VIA FAX AT 304-558-4115. DEADLINE FOR ALL TECHNICAL QUESTIONS IS 04/03/2012 AT 4:00 PM, ALL TECHNICAL QUESTIONS WILL BE ADDRESSED BY AN ADDENDUM AFTER THE DEADLINE.</p> <p>BANKRUPTCY: IN THE EVENT THE VENDOR/CONTRACTOR FILES FOR BANKRUPTCY PROTECTION, THE STATE MAY DEEM THE CONTRACT NULL AND VOID, AND TERMINATE SUCH CONTRACT WITHOUT FURTHER ORDER.</p> <p>THE MODEL/BRAND/SPECIFICATIONS NAMED HEREIN ESTABLISH THE ACCEPTABLE LEVEL OF QUALITY ONLY AND ARE NOT INTENDED TO REFLECT A PREFERENCE OR FAVOR ANY PARTICULAR BRAND OR VENDOR. VENDORS WHO ARE BIDDING ALTERNATES SHOULD SO STATE AND INCLUDE PERTINENT LITERATURE AND SPECIFICATIONS. FAILURE TO PROVIDE INFORMATION FOR ANY ALTERNATES MAY BE GROUNDS FOR REJECTION OF THE BID. THE STATE RESERVES THE RIGHT TO WAIVE MINOR IRREGULARITIES IN BIDS OR SPECIFICATIONS IN ACCORDANCE WITH SECTION 148-1-4(F) OF THE WEST VIRGINIA LEGISLATIVE RULES AND REGULATIONS.</p>						



SEE REVERSE SIDE FOR TERMS AND CONDITIONS

SIGNATURE: <i>Ruck Bue</i>	TELEPHONE: 304 453 6154	DATE: 4-13-2012
TITLE: <i>GM</i>	FEIN:	ADDRESS CHANGES TO BE NOTED ABOVE

WHEN RESPONDING TO RFQ, INSERT NAME AND ADDRESS IN SPACE ABOVE LABELED 'VENDOR'

GENERAL TERMS & CONDITIONS
REQUEST FOR QUOTATION (RFQ) AND REQUEST FOR PROPOSAL (RFP)

1. Awards will be made in the best interest of the State of West Virginia.
2. The State may accept or reject in part, or in whole, any bid.
3. Prior to any award, the apparent successful vendor must be properly registered with the Purchasing Division and have paid the required \$125 fee.
4. All services performed or goods delivered under State Purchase Order/Contracts are to be continued for the term of the Purchase Order/Contracts, contingent upon funds being appropriated by the Legislature or otherwise being made available. ~~In the event funds are not appropriated or otherwise available for these services or goods this Purchase Order/Contract becomes void and of no effect after June 30.~~
5. Payment may only be made after the delivery and acceptance of goods or services.
6. Interest may be paid for late payment in accordance with the *West Virginia Code*.
7. Vendor preference will be granted upon written request in accordance with the *West Virginia Code*.
8. The State of West Virginia is exempt from federal and state taxes and will not pay or reimburse such taxes.
9. The Director of Purchasing may cancel any Purchase Order/Contract upon 30 days written notice to the seller.
10. The laws of the State of West Virginia and the *Legislative Rules* of the Purchasing Division shall govern the purchasing process.
11. Any reference to automatic renewal is hereby deleted. The Contract may be renewed only upon mutual written agreement of the parties.
12. **BANKRUPTCY:** In the event the vendor/contractor files for bankruptcy protection, the State may deem this contract null and void, and terminate such contract without further order.
13. **HIPAA BUSINESS ASSOCIATE ADDENDUM:** The West Virginia State Government HIPAA Business Associate Addendum (BAA), approved by the Attorney General, is available online at www.state.wv.us/admin/purchase/vrc/hipaa.html and is hereby made part of the agreement provided that the Agency meets the definition of a Cover Entity (45 CFR §160.103) and will be disclosing Protected Health Information (45 CFR §160.103) to the vendor.
14. **CONFIDENTIALITY:** The vendor agrees that he or she will not disclose to anyone, directly or indirectly, any such personally identifiable information or other confidential information gained from the agency, unless the individual who is the subject of the information consents to the disclosure in writing or the disclosure is made pursuant to the agency's policies, procedures, and rules. Vendor further agrees to comply with the Confidentiality Policies and Information Security Accountability Requirements, set forth in <http://www.state.wv.us/admin/purchase/privacy/noticeConfidentiality.pdf>.
15. **LICENSING:** Vendors must be licensed and in good standing in accordance with any and all state and local laws and requirements by any state or local agency of West Virginia, including, but not limited to, the West Virginia Secretary of State's Office, the West Virginia Tax Department, and the West Virginia Insurance Commission. The vendor must provide all necessary releases to obtain information to enable the director or spending unit to verify that the vendor is licensed and in good standing with the above entities.
16. **ANTITRUST:** In submitting a bid to any agency for the State of West Virginia, the bidder offers and agrees that if the bid is accepted the bidder will convey, sell, assign or transfer to the State of West Virginia all rights, title and interest in and to all causes of action it may now or hereafter acquire under the antitrust laws of the United States and the State of West Virginia for price fixing and/or unreasonable restraints of trade relating to the particular commodities or services purchased or acquired by the State of West Virginia. Such assignment shall be made and become effective at the time the purchasing agency tenders the initial payment to the bidder.

I certify that this bid is made without prior understanding, agreement, or connection with any corporation, firm, limited liability company, partnership, or person or entity submitting a bid for the same material, supplies, equipment or services and is in all respects fair and without collusion or Fraud. I further certify that I am authorized to sign the certification on behalf of the bidder or this bid.

INSTRUCTIONS TO BIDDERS

1. Use the quotation forms provided by the Purchasing Division. Complete all sections of the quotation form.
2. Items offered must be in compliance with the specifications. Any deviation from the specifications must be clearly indicated by the bidder. Alternates offered by the bidder as **EQUAL** to the specifications must be clearly defined. A bidder offering an alternate should attach complete specifications and literature to the bid. The Purchasing Division may waive minor deviations to specifications.
3. Unit prices shall prevail in case of discrepancy. All quotations are considered F.O.B. destination unless alternate shipping terms are clearly identified in the quotation.
4. All quotations must be delivered by the bidder to the office listed below prior to the date and time of the bid opening. Failure of the bidder to deliver the quotations on time will result in bid disqualifications: Department of Administration, Purchasing Division, 2019 Washington Street East, P.O. Box 50130, Charleston, WV 25305-0130
5. Communication during the solicitation, bid, evaluation or award periods, except through the Purchasing Division, is strictly prohibited (W.Va. C.S.R. §148-1-6.6).



State of West Virginia
 Department of Administration
 Purchasing Division
 2019 Washington Street East
 Post Office Box 50130
 Charleston, WV 25305-0130

Request for Quotation

RFQ NUMBER
AGR1225

PAGE
2

ADDRESS CORRESPONDENCE TO ATTENTION OF:
FRANK WHITTAKER 304-558-2316

VENDOR

*709053227 304-453-6154
 MCCOY FREIGHTLINER INC
 PO BOX 438
 KENOVA WV 25530-0438

SHIP TO

DEPARTMENT OF AGRICULTURE
 FOOD DISTRIBUTION PROGRAM
 1 CEDAR LAKES DRIVE
 RIPLEY, WV
 25271 304-558-2221

DATE PRINTED	TERMS OF SALE	SHIP VIA	F.O.B.	FREIGHT TERMS
03/18/2012				

BID OPENING DATE: **04/18/2012** BID OPENING TIME **01:30PM**

LINE	QUANTITY	UOP	CAT. NO.	ITEM NUMBER	UNIT PRICE	AMOUNT
<p>NOTICE</p> <p>A SIGNED BID MUST BE SUBMITTED TO:</p> <p>DEPARTMENT OF ADMINISTRATION PURCHASING DIVISION BUILDING 15 2019 WASHINGTON STREET, EAST CHARLESTON, WV 25305-0130</p> <p>THE BID SHOULD CONTAIN THIS INFORMATION ON THE FACE OF THE ENVELOPE OR THE BID MAY NOT BE CONSIDERED:</p> <p>SEALED BID</p> <p>BUYER: 44</p> <p>RFQ. NO.: AGR1225</p> <p>BID OPENING DATE: 04/18/2012</p> <p>BID OPENING TIME: 1:30 PM</p> <p>PLEASE PROVIDE A FAX NUMBER IN CASE IT IS NECESSARY TO CONTACT YOU REGARDING YOUR BID:</p> <p>-----</p> <p>CONTACT PERSON (PLEASE PRINT CLEARLY):</p>						

SEE REVERSE SIDE FOR TERMS AND CONDITIONS

SIGNATURE <i>Ruck Bar</i>	TELEPHONE 304 453(6154)	DATE 4.13.2012
TITLE <i>GM</i>	FEIN	ADDRESS CHANGES TO BE NOTED ABOVE

WHEN RESPONDING TO RFQ, INSERT NAME AND ADDRESS IN SPACE ABOVE LABELED 'VENDOR'



State of West Virginia
 Department of Administration
 Purchasing Division
 2019 Washington Street East
 Post Office Box 50130
 Charleston, WV 25305-0130

Request for Quotation

RFQ NUMBER
AGR1225

PAGE
3

ADDRESS CORRESPONDENCE TO ATTENTION OF:
FRANK WHITTAKER 304-558-2316

VENDOR

*709053227 304-453-6154
 MCCOY FREIGHTLINER INC
 PO BOX 438
 KENOVA WV 25530-0438

SHIP TO

DEPARTMENT OF AGRICULTURE
 FOOD DISTRIBUTION PROGRAM
 1 CEDAR LAKES DRIVE
 RIPLEY, WV
 25271 304-558-2221

DATE PRINTED	TERMS OF SALE	SHIP VIA	F.O.B.	FREIGHT TERMS
03/18/2012				

BID OPENING DATE: 04/18/2012 BID OPENING TIME 01:30PM

LINE	QUANTITY	UOP	CAT. NO.	ITEM NUMBER	UNIT PRICE	AMOUNT

***** THIS IS THE END OF RFQ AGR1225 ***** TOTAL :						\$97,770.00

SEE REVERSE SIDE FOR TERMS AND CONDITIONS

SIGNATURE <i>Rock Ben</i>	TELEPHONE 304-453-6154	DATE 4-13-2012
TITLE <i>GM</i>	FEIN	ADDRESS CHANGES TO BE NOTED ABOVE

WHEN RESPONDING TO RFQ, INSERT NAME AND ADDRESS IN SPACE ABOVE LABELED 'VENDOR'

NEW TRUCK SPECIFICATIONS

MODEL: 2012 OR NEWER CLASS 8 DAY CAB TANDEM TRACTOR

WHEELBASE: TO ACCOMMODATE A 32 TO 48 FOOT REEFER TRAILER

ENGINE: CUMMINS ISX15 OR DETROIT DD15 OR EQUAL
 MIN. HP 450 TO MAX HP 500, JACCOBS ENGINE BRAKE OR
 EQUIVALENT, NO EXHAUST ENGINE BRAKE
 ENGINE BLOCK HEATER 1500 WATTS
 EXHAUST SINGLE VERTICAL STAINLESS STEEL FROM MOTOR WITH GUARD

TRANSMISSION: 10 SPEED OR EQUIVALENT

MUST MEET OR EXCEED THE FOLLOWING:

CAB INTERIOR
 AND EXTERIOR: AIR CONDITIONER WITH HEAT AND FILTER
 FULL GAUGE PACKAGE
 POWER WINDOWS BOTH SIDES
 MIRRORS--- REMOTE CONTROLLED WITH BUILT IN CONVEX AND HEATED
 MIN. 10 INCH CONVEX MOUNTED ON LH & RH FRONT FENDER OR HOOD
 RADIO--- AM-FM-CD-WEATHER-GPS AND BLUE TOOTH
 PREWIRED FOR CB RADIO INCLUDING DUAL MOUNTED ANTENNA'S ON
 MIRRORS
 BOTH SEATS BOSTROM HIGH PROFILE (910 OR BAJH) OR EQUAL
 SUN VISOR- INTERIOR BOTH SIDES PADDED
 POWER STEERING
 TILT & TELESCOPIC STEERING & SMALLEST STEERING WHEEL AVAILABLE
 FOR UNIT
 CRUISE CONTROL
 ANTI SAIL MUD FLAPS WITH STAINLESS MOUNTS
 ROOF MOUNTED AIR DEFLECTOR NOT TO EXCEED 12.5' TOTAL TRUCK
 HIGHT
 CAT WALK MOUNTED BEHIND CAB
 ALL PIGTAILS SPRING MOUNTED ON BACK OF CAB WITH GLAD HAND
 MOUNT, 12VOLT PIGTAIL TO CHARGE LIFTGATE ON TRAILER
 STAINLESS FRONT BUMPER

FUEL TANKS: MINIMUM 100 GAL. LH & 100 GAL. RH ALUM. WITH STAINLESS MOUNTS
 AND STRAPS

FRONT AXLE: MINIMUM 12,000# CAP. STEP BACK FOR TIGHT TURNING
 SPRINGS: FLAT LEAF OR TAPERLEAF
 HUBS: OIL SOAK

REAR AXLE: MINIMUM 40,000# CAP. TANDEM WITH DRIVER CONTROLLED
DIFFERENTIAL LOCK SUSPENSION: AIR RIDE WITH INSIDE CAB MOUNT
DUMP VALVE. GEARED TO MATAIN 70 MPH AT 300-RPM BELOW GOVENOR
ON ENGINE

TIRES & WHEELS: 11R22.5 STEER & 11R22.5 ALL SEASON ON REAR (NO LOW PROFILE) 16 PLY
WHEELS: ALLOY

BRAKES: "S" CAM BRAKES WITH AUTO ADJUSTERS
AIR DRYER: BENDIX "SYSTEM GUARD" AD-9 OR EQUAL
AIR RESERVOIRS: 3 TANKS MINIMUM
(5690 CUBIC INCHES TOTAL MIN. CAP.)

ELECTRICAL: ALUM. BATTERY BOX & COVERS -- 12 VOLT SYSTEM

FIFTH WHEEL: FONTAINE NO-SLACK II, C7000 SERIES WITH AIR SLIDE 24 INCH TRAVEL
OR EQUAL

WARRENTY: 3 YEAR BUMPER TO BUMPER

BID MUST INCLUDE DELIVERY

Equipment to be delivered fully assembled and operational within ninety days of bid award.

West Virginia Department of Agriculture
Food Distribution Program
4496 Cedar Lakes Drive
Ripley, WV 25271

COST SHEET

EQUIPMENT MAKE	MODEL	COST
Freightliner	CASCADIA	\$97,770.00
ADDITIONAL EQUIPMENT FEES		
TOTAL COST		\$97,770.00

ALL BIDS MUST INCLUDE ALL FEES FOR DELIVERY TO:

West Virginia Department of Agriculture
Food Distribution Program
4496 Cedar Lakes Drive
Ripley, WV 25271

State of West Virginia VENDOR PREFERENCE CERTIFICATE

Certification and application* is hereby made for Preference in accordance with *West Virginia Code*, §5A-3-37. (Does not apply to construction contracts). *West Virginia Code*, §5A-3-37, provides an opportunity for qualifying vendors to request (at the time of bid) preference for their residency status. Such preference is an evaluation method only and will be applied only to the cost bid in accordance with the *West Virginia Code*. This certificate for application is to be used to request such preference. The Purchasing Division will make the determination of the Resident Vendor Preference, if applicable.

1. **Application is made for 2.5% resident vendor preference for the reason checked:**
 Bidder is an individual resident vendor and has resided continuously in West Virginia for four (4) years immediately preceding the date of this certification; or,
 Bidder is a partnership, association or corporation resident vendor and has maintained its headquarters or principal place of business continuously in West Virginia for four (4) years immediately preceding the date of this certification; or 80% of the ownership interest of Bidder is held by another individual, partnership, association or corporation resident vendor who has maintained its headquarters or principal place of business continuously in West Virginia for four (4) years immediately preceding the date of this certification; or,
 Bidder is a nonresident vendor which has an affiliate or subsidiary which employs a minimum of one hundred state residents and which has maintained its headquarters or principal place of business within West Virginia continuously for the four (4) years immediately preceding the date of this certification; or,
2. **Application is made for 2.5% resident vendor preference for the reason checked:**
 Bidder is a resident vendor who certifies that, during the life of the contract, on average at least 75% of the employees working on the project being bid are residents of West Virginia who have resided in the state continuously for the two years immediately preceding submission of this bid; or,
3. **Application is made for 2.5% resident vendor preference for the reason checked:**
 Bidder is a nonresident vendor employing a minimum of one hundred state residents or is a nonresident vendor with an affiliate or subsidiary which maintains its headquarters or principal place of business within West Virginia employing a minimum of one hundred state residents who certifies that, during the life of the contract, on average at least 75% of the employees or Bidder's affiliate's or subsidiary's employees are residents of West Virginia who have resided in the state continuously for the two years immediately preceding submission of this bid; or,
4. **Application is made for 5% resident vendor preference for the reason checked:**
 Bidder meets either the requirement of both subdivisions (1) and (2) or subdivision (1) and (3) as stated above; or,
5. **Application is made for 3.5% resident vendor preference who is a veteran for the reason checked:**
 Bidder is an individual resident vendor who is a veteran of the United States armed forces, the reserves or the National Guard and has resided in West Virginia continuously for the four years immediately preceding the date on which the bid is submitted; or,
6. **Application is made for 3.5% resident vendor preference who is a veteran for the reason checked:**
 Bidder is a resident vendor who is a veteran of the United States armed forces, the reserves or the National Guard, if, for purposes of producing or distributing the commodities or completing the project which is the subject of the vendor's bid and continuously over the entire term of the project, on average at least seventy-five percent of the vendor's employees are residents of West Virginia who have resided in the state continuously for the two immediately preceding years.

Bidder understands if the Secretary of Revenue determines that a Bidder receiving preference has failed to continue to meet the requirements for such preference, the Secretary may order the Director of Purchasing to: (a) reject the bid; or (b) assess a penalty against such Bidder in an amount not to exceed 5% of the bid amount and that such penalty will be paid to the contracting agency or deducted from any unpaid balance on the contract or purchase order.

By submission of this certificate, Bidder agrees to disclose any reasonably requested information to the Purchasing Division and authorizes the Department of Revenue to disclose to the Director of Purchasing appropriate information verifying that Bidder has paid the required business taxes, provided that such information does not contain the amounts of taxes paid nor any other information deemed by the Tax Commissioner to be confidential.

Under penalty of law for false swearing (*West Virginia Code*, §61-5-3), Bidder hereby certifies that this certificate is true and accurate in all respects; and that if a contract is issued to Bidder and if anything contained within this certificate changes during the term of the contract, Bidder will notify the Purchasing Division in writing immediately.

Bidder: Moby Freight, Inc Signed: Ruck Bure
 Date: 4-13-2012 Title: bnn

*Check any combination of preference consideration(s) indicated above, which you are entitled to receive.

RFQ No. ABR 1225

STATE OF WEST VIRGINIA
Purchasing Division

PURCHASING AFFIDAVIT

West Virginia Code §5A-3-10a states: No contract or renewal of any contract may be awarded by the state or any of its political subdivisions to any vendor or prospective vendor when the vendor or prospective vendor or a related party to the vendor or prospective vendor is a debtor and the debt owned is an amount greater than one thousand dollars in the aggregate

DEFINITIONS:
"Debt" means any assessment, premium, penalty, fine, tax or other amount of money owed to the state or any of its political subdivisions because of a judgment, fine, permit violation, license assessment, defaulted workers' compensation premium, penalty or other assessment presently delinquent or due and required to be paid to the state or any of its political subdivisions, including any interest or additional penalties accrued thereon.

"Debtor" means any individual, corporation, partnership, association, Limited Liability Company or any other form or business association owing a debt to the state or any of its political subdivisions. "Political subdivision" means any county commission; municipality; county board of education; any instrumentality established by a county or municipality; any separate corporation or instrumentality established by one or more counties or municipalities, as permitted by law; or any public body charged by law with the performance of a government function or whose jurisdiction is coextensive with one or more counties or municipalities. "Related party" means a party, whether an individual, corporation, partnership, association, limited liability company or any other form or business association or other entity whatsoever, related to any vendor by blood, marriage, ownership or contract through which the party has a relationship of ownership or other interest with the vendor so that the party will actually or by effect receive or control a portion of the benefit, profit or other consideration from performance of a vendor contract with the party receiving an amount that meets or exceed five percent of the total contract amount.

EXCEPTION: The prohibition of this section does not apply where a vendor has contested any tax administered pursuant to chapter eleven of this code, workers' compensation premium, permit fee or environmental fee or assessment and the matter has not become final or where the vendor has entered into a payment plan or agreement and the vendor is not in default of any of the provisions of such plan or agreement.

Under penalty of law for false swearing (*West Virginia Code* §61-5-3), it is hereby certified that the vendor affirms and acknowledges the information in this affidavit and is in compliance with the requirements as stated.

WITNESS THE FOLLOWING SIGNATURE

Vendor's Name: McCoy Freightliner Inc

Authorized Signature: Russ Baer GM Date: 4-13-2012

State of WV

County of Wayne, to-wit:

Taken, subscribed, and sworn to before me this 13th day of April, 2012.

My Commission expires October 19, 2019.



NOTARY PUBLIC Pamela A. Cyrus

Prepared for:
 Frank Whittaker
 West Virginia Department of
 Agriculture
 1 Cedar Lakes Drive
 Ripley, WV 25271
 Phone: 304-558-2316

Prepared by:
 Rick Ball
 MCCOY FREIGHTLINER, INC.
 1375 ROUTE 52
 KENOVA, WV 25530
 Phone: 304-453-6154

Q U O T A T I O N

CASCADIA 125 INCH DAY CAB	
SET BACK AXLE - TRACTOR	12,000# DUAL TAPERLEAF FRONT SUSPENSION
DETROIT DD15 14.8L 455 HP @ 1800 RPM, 2000 GOV RPM, 1550 LB/FT @ 1100 RPM	125 INCH BBC ALUMINUM CONVENTIONAL CAB
EATON FULLER FRO-15210C TRANSMISSION	4575MM (180 INCH) WHEELBASE
DETROIT DA-RT-40.0-4 HT 40,000# R-SERIES TANDEM REAR AXLE	FONTAINE NO-SLACK II 7000 SERIES CATB 24.0 INCH AIR SLIDE CLEAN CONNECT (LOW LUBE) FIFTH WHEEL - 2 INCH SLIDE INCREMENTS
AIRLINER 40,000# REAR SUSPENSION	9/32X3-7/16X10-1/16 INCH STEEL FRAME (7.14MMX255.6MM/0.281X10.06 INCH) 120KSI
DETROIT DA-F-12.0-3 12,000# FF1 71.5 KPI/3.74 DROP SINGLE FRONT AXLE	1450MM (57 INCH) REAR FRAME OVERHANG

			PER UNIT		TOTAL
VEHICLE PRICE	TOTAL # OF UNITS (1)	\$	95,358	\$	95,358
EXTENDED WARRANTY		\$	2,412	\$	2,412
DEALER INSTALLED OPTIONS		\$	0	\$	0
CUSTOMER PRICE BEFORE TAX		\$	97,770	\$	97,770

TAXES AND FEES					
TAXES AND FEES		\$	0	\$	0
OTHER CHARGES		\$	0	\$	0

TRADE-IN					
TRADE-IN ALLOWANCE		\$	(0)	\$	(0)
BALANCE DUE	(LOCAL CURRENCY)	\$	97,770	\$	97,770

COMMENTS:
 Projected delivery on ___ / ___ / ___ provided the order is received before ___ / ___ / ___.

APPROVAL:
 Please indicate your acceptance of this quotation by signing below:

Customer: X _____ Date: ___ / ___ / ___.



Prepared for:
Frank Whittaker
West Virginia Department of
Agriculture
1 Cedar Lakes Drive
Ripley, WV 25271
Phone: 304-558-2316

Prepared by:
Rick Ball
MCCOY FREIGHTLINER, INC.
1375 ROUTE 52
KENOVA, WV 25530
Phone: 304-453-6154

A proposal for
West Virginia Department of Agriculture

Prepared by
MCCOY FREIGHTLINER, INC.
Rick Ball

Apr 13, 2012

Freightliner CA125DC

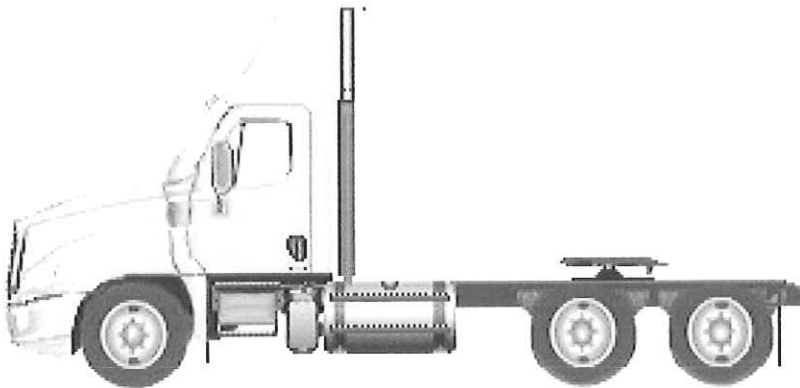

Components shown may not reflect all spec'd options and are not to scale

Prepared for:
 Frank Whittaker
 West Virginia Department of
 Agriculture
 1 Cedar Lakes Drive
 Ripley, WV 25271
 Phone: 304-558-2316

Prepared by:
 Rick Ball
 MCCOY FREIGHTLINER, INC.
 1375 ROUTE 52
 KENOVA, WV 25530
 Phone: 304-453-6154

S P E C I F I C A T I O N P R O P O S A L

Data Code	Description	Weight Front	Weight Rear	Retail Price
Price Level				
PRL-03C	CASCADIA PRL-03C (EFF:01/25/12)			STD
Data Version				
DRL-002	SPECPRO21 DATA RELEASE VER 002			N/C
Vehicle Configuration				
001-231	CASCADIA 125 INCH DAY CAB	9,082	6,850	\$166,250.00
004-212	2012 MODEL YEAR SPECIFIED			STD
002-002	SET BACK AXLE - TRACTOR			STD
003-001	LH PRIMARY STEERING LOCATION			STD
General Service				
AA1-001	TRACTOR/TRAILER CONFIGURATION			STD
AA6-002	DOMICILED, USA (EXCLUDING CALIFORNIA AND CARB OPT-IN STATES)			STD
A85-005	LINEHAUL/LONG HAUL SERVICE			STD
A84-1GM	GOVERNMENT BUSINESS SEGMENT			N/C
AA4-001	GENERAL FREIGHT COMMODITY			STD
AA5-002	TERRAIN/DUTY: 100% (ALL) OF THE TIME, IN TRANSIT, IS SPENT ON PAVED ROADS			STD
AB1-008	MAXIMUM 8% EXPECTED GRADE			STD
AB5-001	SMOOTH CONCRETE OR ASPHALT PAVEMENT - MOST SEVERE IN-TRANSIT (BETWEEN SITES) ROAD SURFACE			STD
995-1AD	FREIGHTLINER LEVEL I WARRANTY			STD
A66-99D	EXPECTED FRONT AXLE(S) LOAD : 12000.0 lbs			
A68-99D	EXPECTED REAR DRIVE AXLE(S) LOAD : 40000.0 lbs			
A63-99D	EXPECTED GROSS VEHICLE WEIGHT CAPACITY : 52000.0 lbs			
A70-99D	EXPECTED GROSS COMBINATION WEIGHT : 52000.0 lbs			
GVWR	RATED MAXIMUM VEHICLE CAPACITY - GVWR : 52000.0 lbs			N/C



Prepared for:
 Frank Whittaker
 West Virginia Department of
 Agriculture
 1 Cedar Lakes Drive
 Ripley, WV 25271
 Phone: 304-558-2316

Prepared by:
 Rick Ball
 MCCOY FREIGHTLINER, INC.
 1375 ROUTE 52
 KENOVA, WV 25530
 Phone: 304-453-6154

Data Code	Description	Weight Front	Weight Rear	Retail Price
Tractor Service				
AA2-001	VAN TRAILER			STD
AH6-001	SINGLE (1) TRAILER			STD
Engine				
101-2HD	DETROIT DD15 14.8L 455 HP @ 1800 RPM, 2000 GOV RPM, 1550 LB/FT @ 1100 RPM			STD
Electronic Parameters				
79A-075	75 MPH ROAD SPEED LIMIT			STD
79B-000	CRUISE CONTROL SPEED LIMIT SAME AS ROAD SPEED LIMIT			N/C
79D-002	1650 RPM ENGINE HARD AND SOFT LIMIT FOR PROGRESSIVE SHIFTING			N/C
79K-007	PTO MODE ENGINE RPM LIMIT - 1100 RPM			N/C
79M-002	PTO MODE BRAKE OVERRIDE - SERVICE AND PARK BRAKE ENABLED			N/C
79N-001	PTO MODE CLUTCH OVERRIDE - CLUTCH ENABLED			N/C
79P-002	PTO RPM WITH CRUISE SET SWITCH - 700 RPM			N/C
79Q-003	PTO RPM WITH CRUISE RESUME SWITCH - 800 RPM			N/C
79S-001	PTO MODE CANCEL VEHICLE SPEED - 5 MPH			N/C
79T-001	PTO MODE RPM INCREMENT - 25 RPM			N/C
79U-007	PTO GOVERNOR RAMP RATE - 250 RPM PER SECOND			N/C
79W-001	ONE REMOTE PTO SPEED			N/C
79X-005	REMOTE PTO SPEED 1 SETTING - 900 RPM			N/C
80G-001	PTO MINIMUM RPM - 600			N/C
Engine Equipment				
99C-010	2010 EPA/CARB EMISSION CERTIFICATION			STD
99D-010	NO 2008 CARB EMISSION CERTIFICATION			STD
105-001	ENGINE MOUNTED OIL CHECK AND FILL			STD
133-004	ONE PIECE VALVE COVER			STD
014-1B2	LOWER WINDSHIELD AIR INTAKE WITH ENGINE MOUNTED AIR CLEANER			STD
124-1D7	DR 12V 160 AMP 28-SI QUADRAMOUNT PAD ALTERNATOR WITH REMOTE BATTERY VOLT SENSE			STD
292-071	(3) ALLIANCE MODEL 1231, GROUP 31, 12 VOLT MAINTENANCE FREE 3375 CCA THREADED STUD BATTERIES			STD



Prepared for:
 Frank Whittaker
 West Virginia Department of
 Agriculture
 1 Cedar Lakes Drive
 Ripley, WV 25271
 Phone: 304-558-2316

Prepared by:
 Rick Ball
 MCCOY FREIGHTLINER, INC.
 1375 ROUTE 52
 KENOVA, WV 25530
 Phone: 304-453-6154

Data Code	Description	Weight Front	Weight Rear	Retail Price
290-1D3	STEEL BATTERY BOX WITH ENCLOSED TRAY			STD
282-001	SINGLE BATTERY BOX FRAME MOUNTED LH SIDE UNDER CAB			STD
291-017	WIRE GROUND RETURN FOR BATTERY CABLES WITH ADDITIONAL FRAME GROUND RETURN			STD
289-013	POLISHED DIAMOND PLATE BATTERY BOX COVER			\$698.00
306-015	PROGRESSIVE LOW VOLTAGE DISCONNECT AT 12.3 VOLTS FOR DESIGNATED CIRCUITS			STD
180-1AM	EATON SOLO ADVANTAGE 15-1/2 INCH SELF ADJUSTING CLUTCH			STD
183-008	TORQUE LIMITING CLUTCH BRAKE			STD
181-002	ZERK FITTING WITH EXTENSION HOSE AT CLUTCH RELEASE BEARING			STD
107-044	BW MODEL BA-921 19.0 CFM SINGLE CYLINDER AIR COMPRESSOR WITH SAFETY VALVE			STD
108-002	STANDARD AIR COMPRESSOR GOVERNOR			STD
131-013	AIR COMPRESSOR DISCHARGE LINE			STD
152-041	ELECTRONIC ENGINE INTEGRAL SHUTDOWN PROTECTION SYSTEM			STD
128-002	JACOBS COMPRESSION BRAKE			STD
016-1C1	RH OUTBOARD UNDER STEP MOUNTED HORIZONTAL AFTERTREATMENT SYSTEM ASSEMBLY WITH RH FRAME MOUNTED VERTICAL TAILPIPE (ROUTED UNDER/INSIDE RAIL)			STD
28F-002	ENGINE AFTERTREATMENT DEVICE, AUTOMATIC OVER THE ROAD REGENERATION AND DASH MOUNTED REGENERATION REQUEST SWITCH			STD
239-050	12 FOOT 06 INCH (150 INCH+0/-5 INCH) EXHAUST SYSTEM HEIGHT			\$7.00
233-001	BRIGHT UPPER STACK(S)			\$381.00
237-1E5	RH CURVED VERTICAL TAILPIPE BACK OF CAB FRAME MOUNTED ROUTED BETWEEN RAILS OVER FRAME			STD
23U-002	13 GALLON DIESEL EXHAUST FLUID TANK			STD
23Z-001	POLISHED ALUMINUM DIAMOND PLATE DIESEL EXHAUST FLUID TANK COVER			\$262.00
43Y-001	STANDARD DIESEL EXHAUST FLUID TANK CAP			STD
242-001	STAINLESS STEEL AFTERTREATMENT DEVICE/MUFFLER/TAILPIPE SHIELD			N/C
273-018	HORTON DRIVEMASTER ON/OFF FAN DRIVE			\$57.00



Prepared for:
 Frank Whittaker
 West Virginia Department of
 Agriculture
 1 Cedar Lakes Drive
 Ripley, WV 25271
 Phone: 304-558-2316

Prepared by:
 Rick Ball
 MCCOY FREIGHTLINER, INC.
 1375 ROUTE 52
 KENOVA, WV 25530
 Phone: 304-453-6154

Data Code	Description	Weight Front	Weight Rear	Retail Price
276-001	AUTOMATIC FAN CONTROL WITHOUT DASH SWITCH, NON ENGINE MOUNTED			STD
110-068	DDC SUPPLIED ENGINE MOUNTED FUEL FILTER/FUEL WATER SEPARATOR WITH WATER-IN-FUEL INDICATOR			STD
118-001	FULL FLOW OIL FILTER			STD
120-036	DDC SUPPLIED COOLANT FILTER, ENGINE MOUNTED			STD
266-082	1625 SQUARE INCH ALUMINUM RADIATOR			STD
103-004	ANTIFREEZE TO -34F, NOAT EXTENDED LIFE COOLANT			STD
171-007	GATES BLUE STRIPE COOLANT HOSES OR EQUIVALENT			STD
172-001	CONSTANT TENSION HOSE CLAMPS FOR COOLANT HOSES			STD
270-016	RADIATOR DRAIN VALVE			STD
138-005	PHILLIPS-TEMRO 1500 WATT/115 VOLT BLOCK HEATER	4		\$156.00
140-038	CHROME ENGINE HEATER RECEPTACLE MOUNTED UNDER LH DOOR WITH CURRENT SENSOR LIGHT			\$93.00
134-001	ALUMINUM FLYWHEEL HOUSING			STD
155-065	DELCO 12V 39MT+ HD/OCP STARTER WITH THERMAL PROTECTION AND INTEGRATED MAGNETIC SWITCH			STD
Transmission				
342-417	EATON FULLER FRO-15210C TRANSMISSION			STD
Transmission Equipment				
347-002	ALUMINUM CLUTCH HOUSING			STD
341-017	MAGNETIC PLUGS, ENGINE DRAIN, TRANSMISSION FILL AND DRAIN, AXLE(S) FILL AND DRAIN			STD
345-001	PAINTED SHIFT LEVER, SOLID LINKAGE			STD
370-015	WATER TO OIL TRANSMISSION COOLER, IN RADIATOR END TANK			STD
35T-003	SYNTHETIC TRANSMISSION LUBE			STD
Front Axle and Equipment				
400-1A6	DETROIT DA-F-12.0-3 12,000# FF1 71.5 KPI/3.74 DROP SINGLE FRONT AXLE			STD
402-084	MERITOR 16.5X5 Q+ STAMPED SPIDER CAM FRONT BRAKES, DOUBLE ANCHOR, FABRICATED SHOES			STD



Prepared for:
 Frank Whittaker
 West Virginia Department of
 Agriculture
 1 Cedar Lakes Drive
 Ripley, WV 25271
 Phone: 304-558-2316

Prepared by:
 Rick Ball
 MCCOY FREIGHTLINER, INC.
 1375 ROUTE 52
 KENOVA, WV 25530
 Phone: 304-453-6154

Data Code	Description	Weight Front	Weight Rear	Retail Price
403-043	2011-FMVSS 121 FRONT BRAKE LINING			STD
419-023	CONMET CAST IRON FRONT BRAKE DRUMS			STD
409-006	FRONT OIL SEALS			STD
408-001	VENTED FRONT HUB CAPS WITH WINDOW, CENTER AND SIDE PLUGS - OIL			STD
416-022	STANDARD SPINDLE NUTS FOR ALL AXLES			STD
405-002	MERITOR AUTOMATIC FRONT SLACK ADJUSTERS			STD
536-050	TRW THP-60 POWER STEERING			STD
539-003	POWER STEERING PUMP			STD
534-015	2 QUART SEE THROUGH POWER STEERING RESERVOIR			STD
40T-002	SYNTHETIC 75W-90 FRONT AXLE LUBE			STD
Front Suspension				
620-1F0	12,000# DUAL TAPERLEAF FRONT SUSPENSION			STD
619-005	MAINTENANCE FREE RUBBER BUSHINGS - FRONT SUSPENSION			STD
410-001	FRONT SHOCK ABSORBERS			STD
Rear Axle and Equipment				
420-1GR	DETROIT DA-RT-40.0-4 HT 40,000# R-SERIES TANDEM REAR AXLE			STD
421-373	3.73 REAR AXLE RATIO			N/C
424-001	IRON REAR AXLE CARRIER WITH STANDARD AXLE HOUSING			STD
386-074	MXL 176T MERITOR EXTENDED LUBE MAIN DRIVELINE WITH HALF ROUND YOKES			(\$165.00)
388-073	MXL 17T MERITOR EXTENDED LUBE INTERAXLE DRIVELINE WITH HALF ROUND YOKES			STD
878-019	(1) INTERAXLE LOCK VALVE FOR TANDEM OR TRIDEM DRIVE AXLES			STD
423-008	MERITOR 16.5X8.62 Q+ STAMPED SPIDER CAM REAR BRAKES, DOUBLE ANCHOR, FABRICATED SHOES			STD
433-043	2011-FMVSS 121 REAR BRAKE LININGS			STD
434-005	BRAKE CAMS AND CHAMBERS ON FORWARD SIDE OF DRIVE AXLE(S) WITH AUXILIARY SUPPORT BRACKETS			STD
451-023	CONMET CAST IRON REAR BRAKE DRUMS			STD
440-021	SKF SCOTSEAL PLUS XL REAR OIL SEALS			STD
426-074	HALDEX GOLDSEAL LONGSTROKE 1-DRIVE AXLE SPRING PARKING CHAMBERS			STD



Prepared for:
 Frank Whittaker
 West Virginia Department of
 Agriculture
 1 Cedar Lakes Drive
 Ripley, WV 25271
 Phone: 304-558-2316

Prepared by:
 Rick Ball
 MCCOY FREIGHTLINER, INC.
 1375 ROUTE 52
 KENOVA, WV 25530
 Phone: 304-453-6154

Data Code	Description	Weight Front	Weight Rear	Retail Price
428-002	MERITOR AUTOMATIC REAR SLACK ADJUSTERS			STD
41T-002	SYNTHETIC 75W-90 REAR AXLE LUBE			STD
Rear Suspension				
622-005	AIRLINER 40,000# REAR SUSPENSION			STD
621-007	AIRLINER HIGH POSITION RIDE HEIGHT			STD
431-001	STANDARD U-BOLT PAD			STD
624-016	51 INCH AXLE SPACING			STD
888-047	MANUAL DUMP VALVE FOR AIR SUSPENSION WITHOUT GAUGE			STD
87D-007	INDICATOR LIGHT AND BUZZER FOR EACH MODE SWITCH			STD
910-001	SINGLE AIR REAR SUSPENSION LEVELING VALVE			STD
623-002	TRANSVERSE CONTROL RODS			STD
439-005	REAR SHOCK ABSORBERS - TWO AXLES (TANDEM) (AIR RIDE SUSPENSION)			STD
Brake System				
490-100	WABCO 4S/4M ABS WITHOUT TRACTION CONTROL			STD
871-001	REINFORCED NYLON, FABRIC BRAID AND WIRE BRAID CHASSIS AIR LINES			STD
904-001	FIBER BRAID PARKING BRAKE HOSE			STD
412-001	STANDARD BRAKE SYSTEM VALVES			STD
413-002	STD U.S. FRONT BRAKE VALVE			STD
432-003	RELAY VALVE WITH 5-8 PSI CRACK PRESSURE, NO REAR PROPORTIONING VALVE			STD
480-009	BW AD-9 BRAKE LINE AIR DRYER WITH HEATER	20		N/C
483-003	BENDIX OIL COALESCING FILTER FOR AIR DRYER			N/C
460-001	STEEL AIR BRAKE RESERVOIRS			STD
477-004	PULL CABLES ON ALL AIR RESERVOIR(S)			\$25.00
Trailer Connections				
481-003	12 FOOT STRAIGHT TRAILER AIR HOSE			STD
476-002	36 INCH STAINLESS STEEL SLIDE BAR WITH SPRING TYPE AIR HOSE HANGER			STD
484-032	COMBINATION DUMMY GLAD HANDS AND LIGHT PLUG HOLDER MOUNTED LH BACK OF CAB WITH GROUND ACCESS			STD



Prepared for:
 Frank Whittaker
 West Virginia Department of
 Agriculture
 1 Cedar Lakes Drive
 Ripley, WV 25271
 Phone: 304-558-2316

Prepared by:
 Rick Ball
 MCCOY FREIGHTLINER, INC.
 1375 ROUTE 52
 KENOVA, WV 25530
 Phone: 304-453-6154

Data Code	Description	Weight Front	Weight Rear	Retail Price
296-010	PRIMARY CONNECTOR/RECEPTACLE WIRED FOR SEPARATE STOP/TURN, CENTER PIN POWERED THROUGH IGNITION			STD
297-027	SAE J560 7-WAY PRIMARY TRAILER CABLE RECEPTACLE MOUNTED LOWER LH BACK OF CAB			STD
310-002	12 FOOT DETACHABLE STRAIGHT PRIMARY TRAILER ELECTRICAL CABLE WITH SAE J560 CONNECTOR			STD
Wheelbase & Frame				
545-457	4575MM (180 INCH) WHEELBASE			STD
546-099	9/32X3-7/16X10-1/16 INCH STEEL FRAME (7.14MMX255.6MM/0.281X10.06 INCH) 120KSI			STD
552-012	1450MM (57 INCH) REAR FRAME OVERHANG			STD
55W-005	FRAME OVERHANG RANGE: 51 INCH TO 60 INCH			N/C
AC8-99D	CALC'D BACK OF CAB TO REAR SUSP C/L (CA) : 103.03 in			
AE8-99D	CALCULATED EFFECTIVE BACK OF CAB TO REAR SUSPENSION C/L (CA) : 92.64 in			
AE4-99D	CALC'D FRAME LENGTH - OVERALL : 267.12			
AM6-99D	CALC'D SPACE AVAILABLE FOR DECKPLATE : 61.66 in			
FSS-0LH	FRAME SPACE LH SIDE : 4.02 in			N/C
FSS-0RH	FRAME SPACE RH SIDE : 6.15 in			N/C
553-002	FLANGED TAPERED END OF FRAME			STD
559-001	STANDARD WEIGHT ENGINE CROSSMEMBER			STD
572-001	STANDARD REARMOST CROSSMEMBER			STD
565-001	STANDARD SUSPENSION CROSSMEMBER			STD
Chassis Equipment				
674-001	LH BACK OF CAB ACCESS			STD
592-054	21 INCH (525MM) DECK PLATE FLUSH MOUNTED BETWEEN RAILS	1	1	\$31.00
556-105	14.5 INCH HENDRICKSON AEROCLAD BUMPER, STAINLESS STEEL CLAD ALUMINUM	10		\$996.00
557-001	CENTER STEP RECESSED IN BUMPER			STD
574-007	BUMPER MOUNTING FOR (3) LICENSE PLATES			STD
585-1AJ	BETTS B-7 STAINLESS STEEL MUDFLAP BRACKETS		10	\$85.00
590-008	KONETA SAFETY GUARD ANTI-SPRAY/SAIL BLACK MUDFLAPS, NO LOGO		10	\$4.00
586-015	FRONT ANTI-SPRAY CAB MOUNTED MUDFLAPS			STD



Prepared for:
 Frank Whittaker
 West Virginia Department of
 Agriculture
 1 Cedar Lakes Drive
 Ripley, WV 25271
 Phone: 304-558-2316

Prepared by:
 Rick Ball
 MCCOY FREIGHTLINER, INC.
 1375 ROUTE 52
 KENOVA, WV 25530
 Phone: 304-453-6154

Data Code	Description	Weight Front	Weight Rear	Retail Price
551-002	HUCK-SPIN ROUND COLLAR CHASSIS FASTENERS			STD
Fifth Wheel				
578-1GA	FONTAINE NO-SLACK II 7000 SERIES CATB 24.0 INCH AIR SLIDE CLEAN CONNECT (LOW LUBE) FIFTH WHEEL - 2 INCH SLIDE INCREMENTS		30	\$356.00
577-432	FIFTH WHEEL 432MM (17.0 INCHES) AHEAD OF SUSPENSION CENTERLINE			N/C
582-013	171MM (6.75 INCH) FIFTH WHEEL HEIGHT			N/C
570-001	OUTBOARD ANGLE - FIFTH WHEEL MOUNTING			N/C
890-001	DASH MOUNTED CONTROL VALVE AND PLUMBING FOR FIFTH WHEEL			STD
579-003	SIDE LEFT FIFTH WHEEL RELEASE			N/C
Fuel Tanks				
206-156	100 GALLON/378 LITER ALUMINUM FUEL TANK - RH	5	5	\$24.00
204-156	100 GALLON/378 LITER ALUMINUM FUEL TANK - LH	10		\$26.00
218-006	25 INCH DIAMETER FUEL TANK(S)			STD
215-006	POLISHING OF FUEL/HYDRAULIC TANK(S) WITH POLISHED STAINLESS STEEL BANDS			\$718.00
212-008	FUEL TANK(S) AFT			STD
664-002	POLISHED STEP FINISH			\$326.00
205-002	CHROME FUEL TANK CAP(S)			N/C
216-020	EQUIFLO INBOARD FUEL SYSTEM			STD
202-016	HIGH TEMPERATURE REINFORCED NYLON FUEL LINE			STD
Tires				
093-1GA	GOODYEAR G399 LHS FUEL MAX 11R22.5 16 PLY RADIAL FRONT TIRES (MATCH MARKED)	14		\$244.00
094-0VE	GOODYEAR G288 11R22.5 16 PLY RADIAL REAR TIRES		200	\$1,064.00
Hubs				
418-018	CONMET PRE-SET BEARING ALUMINUM FRONT HUBS			STD
450-018	CONMET PRE-SET BEARING ALUMINUM REAR HUBS			STD
Wheels				
502-506	ACCURIDE 29644A 22.5X8.25 10-HUB PILOT ALUMINUM DISC FRONT WHEELS	-62		\$390.00



Prepared for:
 Frank Whittaker
 West Virginia Department of
 Agriculture
 1 Cedar Lakes Drive
 Ripley, WV 25271
 Phone: 304-558-2316

Prepared by:
 Rick Ball
 MCCOY FREIGHTLINER, INC.
 1375 ROUTE 52
 KENOVA, WV 25530
 Phone: 304-453-6154

Data Code	Description	Weight Front	Weight Rear	Retail Price
505-506	ACCURIDE 29644A 22.5X8.25 10-HUB PILOT ALUMINUM DISC REAR WHEELS		-248	\$1,560.00
524-001	POLISHED FRONT WHEELS; OUTSIDE ONLY			\$66.00
525-001	POLISHED REAR WHEELS; OUTSIDE OF OUTER WHEELS ONLY			\$264.00
496-011	FRONT WHEEL MOUNTING NUTS			STD
497-011	REAR WHEEL MOUNTING NUTS			STD
Cab Exterior				
829-1AF	125 INCH BBC ALUMINUM CONVENTIONAL CAB			STD
653-004	RH CAB DOOR(S) WITH 70 DEGREE DOOR STOP			STD
651-004	LH CAB DOOR(S) WITH 70 DEGREE DOOR STOP			STD
784-063	DAY CAB AIR DEFLECTOR, FACTORY PAINTED AND INSTALLED	90	10	\$1,006.00
783-998	NO SIDE EXTENDERS			STD
650-008	AIR CAB MOUNTS			STD
648-002	NONREMOVABLE BUGSCREEN MOUNTED BEHIND GRILLE			STD
678-003	LH AND RH INTERIOR GRAB HANDLES			STD
646-010	CHROME GRILLE WITH INTEGRAL SURROUND			STD
644-001	AERODYNAMIC HOOD			STD
727-1AH	SINGLE 14 INCH ROUND POLISHED AIR HORN ROOF MOUNTED			STD
726-001	SINGLE ELECTRIC HORN			STD
657-001	DOOR LOCKS AND IGNITION SWITCH KEYED THE SAME			STD
312-043	INTEGRAL HEADLIGHT/MARKER ASSEMBLY			STD
302-072	ROOF MOUNTED LED MARKER LIGHTS			STD
311-001	DAYTIME RUNNING LIGHTS			STD
294-001	INTEGRAL STOP/TAIL/BACKUP LIGHTS			STD
300-043	LED SIDE TURN SIGNAL			STD
318-003	(1) FLUSH UTILITY LIGHT MOUNTED LH BACK OF CAB/SLEEPER			STD
744-1D2	DUAL BLACK HEATED MIRRORS WITH INTEGRAL CONVEX, LH AND RH REMOTE AND RAIN DEFLECTORS			STD
797-001	DOOR MOUNTED MIRRORS			STD
796-001	102 INCH EQUIPMENT WIDTH			STD
74B-1AH	RH AND LH BLACK HOOD/FENDER MOUNTED MIRRORS			STD
729-001	STANDARD SIDE/REAR REFLECTORS			STD



Prepared for:
 Frank Whittaker
 West Virginia Department of
 Agriculture
 1 Cedar Lakes Drive
 Ripley, WV 25271
 Phone: 304-558-2316

Prepared by:
 Rick Ball
 MCCOY FREIGHTLINER, INC.
 1375 ROUTE 52
 KENOVA, WV 25530
 Phone: 304-453-6154

Data Code	Description	Weight Front	Weight Rear	Retail Price
73A-002	REAR REFLECTIVE DEVICE			STD
677-055	RH AFTERTREATMENT SYSTEM CAB ACCESS WITH POLISHED DIAMOND PLATE COVER AND STEPS			\$217.00
768-059	(2) 28X22 INCH SOLAR TINTED REAR WINDOWS			STD
661-016	SOLAR TINTED DOOR GLASS LH AND RH WITH TINTED FORWARD SIDE GLASS			STD
654-011	RH AND LH ELECTRIC POWERED WINDOWS			STD
663-025	2-PIECE SOLAR TINTED CURVED ROPED-IN WINDSHIELD			STD
659-007	8 LITER WINDSHIELD WASHER RESERVOIR, CAB MOUNTED, WITHOUT FLUID LEVEL INDICATOR			STD
Cab Interior				
707-1CW	GRAY VINYL INTERIOR			STD
706-034	STANDARD LH DOOR TRIM			STD
708-034	STANDARD RH DOOR TRIM			STD
772-001	BLACK MATS			STD
785-014	(2) DASH MOUNTED POWER OUTLETS AND COIN TRAY			STD
691-017	FORWARD ROOF MOUNTED CONSOLE WITH CENTER LOCKING DOOR			STD
693-019	LH AND RH DOOR STORAGE POCKETS INTEGRATED INTO MOLDED DOOR PANELS			STD
741-019	COAT HOOK(S) IN CAB			STD
680-017	PARCHMENT/SHALE WING DASH			STD
700-014	HEATER, DEFROSTER AND AIR CONDITIONER WITH CONSTANT OUTLET TEMPERATURE CONTROL			STD
701-002	HVAC DUCTING WITH MAIN FRESH AIR FILTER			STD
703-005	MAIN HVAC CONTROLS WITH RECIRCULATION SWITCH			STD
170-015	STANDARD HEATER PLUMBING			STD
130-033	DENSO HEAVY DUTY AIR CONDITIONER COMPRESSOR			STD
698-001	RADIATOR MOUNTED AIR CONDITIONER CONDENSER			STD
702-002	BINARY CONTROL, R-134A			STD
739-033	STANDARD INSULATION			STD
285-013	SOLID-STATE CIRCUIT PROTECTION AND FUSES			STD
280-007	12V NEGATIVE GROUND ELECTRICAL SYSTEM			N/C



Prepared for:
 Frank Whittaker
 West Virginia Department of
 Agriculture
 1 Cedar Lakes Drive
 Ripley, WV 25271
 Phone: 304-558-2316

Prepared by:
 Rick Ball
 MCCOY FREIGHTLINER, INC.
 1375 ROUTE 52
 KENOVA, WV 25530
 Phone: 304-453-6154

Data Code	Description	Weight Front	Weight Rear	Retail Price
324-1AK	STANDARD CAB LIGHTING			STD
655-005	LH AND RH ELECTRIC DOOR LOCKS			\$93.00
740-998	NO MATTRESS			STD
756-1DD	BASIC HIGH BACK AIR SUSPENSION DRIVER SEAT WITH 1 CHAMBER AIR LUMBAR, INTEGRATED CUSHION EXTENSION AND REAR CUSHION TILT			STD
760-1DD	BASIC HIGH BACK AIR SUSPENSION PASSENGER SEAT WITH 1 CHAMBER AIR LUMBAR, INTEGRATED CUSHION EXTENSION AND REAR CUSHION TILT	40	15	\$307.00
758-036	VINYL WITH VINYL INSERT DRIVER SEAT			STD
761-036	VINYL WITH VINYL INSERT PASSENGER SEAT			STD
763-011	3 POINT ADJUSTABLE D-RING RETRACTOR DRIVER AND PASSENGER SEAT BELTS			STD
532-002	ADJUSTABLE TILT AND TELESCOPING STEERING COLUMN			STD
540-044	4-SPOKE 18 INCH (450MM) BLACK STEERING WHEEL WITH SWITCHES			STD
765-002	DRIVER AND PASSENGER INTERIOR SUN VISORS			STD

Instruments & Controls

732-035	LAZER BLACK DRIVER INSTRUMENT PANEL			STD
870-001	BLACK GAUGE BEZELS			STD
486-001	LOW AIR PRESSURE LIGHT AND BUZZER			STD
840-002	2 INCH PRIMARY AND SECONDARY AIR PRESSURE GAUGES			STD
198-025	INTAKE MOUNTED AIR RESTRICTION INDICATOR WITHOUT GRADUATIONS			STD
149-015	ELECTRONIC CRUISE CONTROL WITH CONTROLS ON STEERING WHEEL SPOKES			STD
156-007	KEY OPERATED IGNITION SWITCH AND INTEGRAL START POSITION; 4 POSITION OFF/RUN/START/ACCESSORY			STD
811-011	ODOMETER/TRIP/HOUR/DIAGNOSTIC/VOLTAGE DISPLAY: 1X7 CHARACTER, 26 WARNING LAMPS, DATA LINKED, ICU3			STD
160-026	GATEWAY DIAGNOSTIC INTERFACE CONNECTOR, 9 PIN, SAE J1939/1587, LOCATED BELOW DASH			STD
844-001	2 INCH ELECTRIC FUEL GAUGE			STD
845-011	FUEL FILTER RESTRICTION INDICATOR			STD

Prepared for:
 Frank Whittaker
 West Virginia Department of
 Agriculture
 1 Cedar Lakes Drive
 Ripley, WV 25271
 Phone: 304-558-2316

Prepared by:
 Rick Ball
 MCCOY FREIGHTLINER, INC.
 1375 ROUTE 52
 KENOVA, WV 25530
 Phone: 304-453-6154

Data Code	Description	Weight Front	Weight Rear	Retail Price
148-003	PROGRAMMABLE RPM CONTROL - ELECTRONIC ENGINE			STD
866-009	DUAL REAR AXLE TEMPERATURE GAUGES WITH SENSOR SHIELD			\$140.00
856-001	ELECTRICAL ENGINE COOLANT TEMPERATURE GAUGE			STD
854-001	ENGINE OIL TEMPERATURE GAUGE			\$35.00
864-001	2 INCH TRANSMISSION OIL TEMPERATURE GAUGE			\$63.00
867-004	ELECTRONIC OUTSIDE TEMPERATURE SENSOR DISPLAY IN DRIVER MESSAGE CENTER			STD
830-017	ENGINE AND TRIP HOUR METERS INTEGRAL WITHIN DRIVER DISPLAY			STD
852-002	ELECTRIC ENGINE OIL PRESSURE GAUGE			STD
746-1A4	DELPHI AM/FM/WB/XM PREMIUM RADIO WITH CD, BLUETOOTH AND MICROPHONE	10		\$807.00
747-001	DASH MOUNTED RADIO			N/C
750-041	STANDARD SPEAKER SYSTEM			N/C
753-998	NO AM/FM RADIO ANTENNA			(\$94.00)
748-006	POWER AND GROUND WIRING PROVISION			STD
749-001	ROOF/OVERHEAD CONSOLE CB RADIO PROVISION WITH FACE PLATE			STD
752-037	DUAL SIDE MOUNT MULTI-BAND AM/FM/CB ANTENNA SYSTEM			\$119.00
78C-003	INTEROPERABLE SDAR ANTENNA			\$111.00
737-998	NO TELEVISION ANTENNA/PROVISION			STD
810-027	ELECTRONIC MPH SPEEDOMETER WITH SECONDARY KPH SCALE, WITHOUT ODOMETER			STD
817-001	STANDARD VEHICLE SPEED SENSOR			STD
812-001	ELECTRONIC 3000 RPM TACHOMETER			STD
813-1B4	DETROIT VIRTUAL TECHNICIAN REMOTE ENGINE DIAGNOSTICS			STD
81X-001	2 YEAR SERVICE CONTRACT INCLUDED WITH VIRTUAL TECHNICIAN			STD
162-002	IGNITION SWITCH CONTROLLED ENGINE STOP			STD
264-033	STEERING WHEEL MOUNTED ELECTRIC HORN CONTROL			STD
482-001	BW TRACTOR PROTECTION VALVE			STD
883-001	TRAILER HAND CONTROL BRAKE VALVE			STD
842-001	2 INCH TURBO AIR PRESSURE GAUGE			\$56.00



Prepared for:
 Frank Whittaker
 West Virginia Department of
 Agriculture
 1 Cedar Lakes Drive
 Ripley, WV 25271
 Phone: 304-558-2316

Prepared by:
 Rick Ball
 MCCOY FREIGHTLINER, INC.
 1375 ROUTE 52
 KENOVA, WV 25530
 Phone: 304-453-6154

Data Code	Description	Weight Front	Weight Rear	Retail Price
836-015	DIGITAL VOLTAGE DISPLAY INTEGRAL WITH DRIVER DISPLAY			STD
660-008	SINGLE ELECTRIC WINDSHIELD WIPER MOTOR WITH DELAY			STD
304-030	ROTARY HEADLAMP SWITCH, MARKER LIGHTS/HEADLIGHTS SWITCH WITH PULL OUT FOR OPTIONAL FOG/ROAD LAMPS			STD
882-004	TWO VALVE PARKING BRAKE SYSTEM WITH WARNING INDICATOR			STD
299-028	MANUAL TURN SIGNAL SWITCH WITH DIMMER, HEADLAMP FLASH, WASH/WIPE/INTERMITTENT			STD
298-046	INTEGRAL ELECTRONIC TURN SIGNAL FLASHER WITH 40 AMP (20 AMP PER SIDE) TRAILER LAMP CAPACITY			STD

Design

065-000	PAINT: ONE SOLID COLOR			STD
---------	------------------------	--	--	-----

Color

980-5F6	CAB COLOR A: L0006EB WHITE ELITE BC			STD
986-020	BLACK, HIGH SOLIDS POLYURETHANE CHASSIS PAINT			STD
979-995	AERO DEVICE PAINTED SAME AS CAB COLOR A			N/C

Certification / Compliance

996-001	U.S. FMVSS CERTIFICATION			STD
---------	--------------------------	--	--	-----

Sales Programs

NO SALES PROGRAMS HAVE BEEN SELECTED

TOTAL VEHICLE SUMMARY

Adjusted List Price

Adjusted List Price ** \$176,778.00

Weight Summary

	Weight Front	Weight Rear	Total Weight
Factory Weight ⁺	9224 LBS	6883 LBS	16107 LBS



Prepared for:
 Frank Whittaker
 West Virginia Department of
 Agriculture
 1 Cedar Lakes Drive
 Ripley, WV 25271
 Phone: 304-558-2316

Prepared by:
 Rick Ball
 MCCOY FREIGHTLINER, INC.
 1375 ROUTE 52
 KENOVA, WV 25530
 Phone: 304-453-6154

Total Weight ⁺	9224 LBS	6883 LBS	16107 LBS
---------------------------	----------	----------	-----------

ITEMS NOT INCLUDED IN ADJUSTED LIST PRICE

Other Factory Charges

R1X-001	2 YEAR SERVICE CONTRACT INCLUDED WITH VIRTUAL TECHNICIAN - PRICING	N/C
	DELIVERY & ORDER PROCESSING CHARGE	\$1,925.00

Extended Warranty

WAH-007	EXTENDED VEHICLE WARRANTY 3 YEARS OR 200,000 MILES/320 000 KM	\$2,412.00
Total Extended Warranty (Local Currency)		\$2,412.00

(+) Weights shown are estimates only.

If weight is critical, contact Customer Application Engineering.

(**) Prices shown do not include taxes, fees, etc... "Net Equipment Selling Price" is located on the Quotation Details Proposal Report.



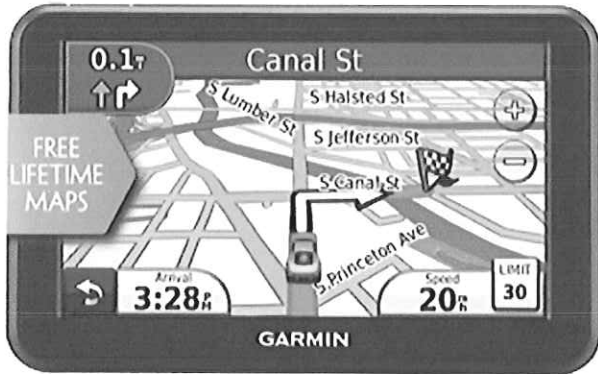

Garmin nuvi 50LM 5" Portable GPS

★★★★★ (38 Customer Reviews) Write a review

Buy from Walmart

Shipping & Pickup

Online

\$119.98

In stock for:

• **Free shipping**

• **Ship to home**

Quantity

1

Add to cart

IN LIMITED STORES

Limited stock in store

In stores

Price may vary

Find in another store

Show this number of items in store.

Product availability, styles, promotions and pricing

Item Description

With a big 5" touchscreen and more than 8 million turn directions, the Garmin nuvi 50LM 5" Portable GPS lets you use the screen to easily look up addresses and service points. The screen also displays turn-by-turn directions that speak street names. The Garmin GPS with lifetime map updates shows you your current location. Its "Where Am I?" emergency locator, you will know your location. The prompt GPS also comes preloaded with more than 100,000 points of interest to add more places. Lane assist with junction view approaching turn or exit, making unfamiliar intersections easier to navigate. The assist GPS realistically displays road signs and junctions to indicate the proper lane for navigation.

Garmin nuvi 50LM 5" Portable GPS:

- 5" WQVGA color TFT display with 480 x 270 pixels brightly for optimal navigation
- Voice navigation - Internal speaker clearly tells you directions
- Preloaded maps - Stay up-to-date with free lifetime map updates
- Lane assist with junction view - Never miss your turn
- Built-in speed limit indicator - Keep out of trouble
- Battery - Rechargeable lithium ion

Specifications



Additional Specifications

Battery Life: 2 hours

Battery

Run Time (Up To): 2 hours

Included Qty: 1

Navigation

Waypoints: 1000

Trip Computer: Avoid highways, trip distance, quickest route, avoid toll roads, fast/short route

Miscellaneous

Included Accessories: Car power adapter, USB cable, vehicle mount, dashboa disc

General

Product Type: GPS receiver

More Information

Model No.: nuvi 50LM

Shipping Weight (in pounds): 1.0

Product in Inches (L x W x H): 5.6 x 4.4 x 2.4

Walmart No.: 550333664