



State of West Virginia
 Department of Administration
 Purchasing Division
 2019 Washington Street East
 Post Office Box 50130
 Charleston, WV 25305-0130

Request for Quotation

RFQ NUMBER
8512C2026

PAGE
1

ADDRESS CORRESPONDENCE TO ATTENTION OF:
PAUL REYNOLDS
304-558-0468

RFQ COPY
TYPE NAME/ADDRESS HERE

VENDOR

ORIGIN ID: TOPA (785) 862-1153
 LOHMANN & RAUSCHER INC
 6700 SW TOPEKA BLVD
 TOPEKA, KS 666191401

SHIP TO

DIVISION OF HIGHWAYS
VARIOUS LOCALES AS INDICATED
BY ORDER

RECEIVED
 NOV 18 2011

BY: *[Signature]*

DATE PRINTED 11/10/2011	TERMS OF SALE	SHIP VIA	F.O.B.	FREIGHT TERMS
-----------------------------------	---------------	----------	--------	---------------

BID OPENING DATE: **11/30/2011** BID OPENING TIME **01:30PM**

LINE	QUANTITY	UOP	CAT. NO.	ITEM NUMBER	UNIT PRICE	AMOUNT
0001		EA		895-74-99-602	See Pricing Pages	
<p>SAFETY VEST AND PULLOVER GARMENTS</p> <p>REQUEST FOR QUOTATION</p> <p>OPEN END CONTRACT</p> <p>THE WEST VIRGINIA STATE PURCHASING DIVISION FOR THE AGENCY, THE WEST VIRGINIA DIVISION OF HIGHWAYS IS SOLICITING BIDS FOR AN OPEN END CONTRACT TO PROVIDE SAFETY VESTS AND PULLOVER GARMENTS PER THE ATTACHED SPECIFICATIONS.</p> <p>EXHIBIT 3</p> <p>LIFE OF CONTRACT: THIS CONTRACT BECOMES EFFECTIVE ON UPON AWARD AND EXTENDS FOR A PERIOD OF ONE (1) YEAR OR UNTIL SUCH "REASONABLE TIME" THEREAFTER AS IS NECESSARY TO OBTAIN A NEW CONTRACT OR RENEW THE ORIGINAL CONTRACT. THE "REASONABLE TIME" PERIOD SHALL NOT EXCEED TWELVE (12) MONTHS. DURING THIS "REASONABLE TIME" THE VENDOR MAY TERMINATE THIS CONTRACT FOR ANY REASON UPON GIVING THE DIRECTOR OF PURCHASING 30 DAYS WRITTEN NOTICE.</p> <p>UNLESS SPECIFIC PROVISIONS ARE STIPULATED ELSEWHERE IN THIS CONTRACT DOCUMENT, THE TERMS, CONDITIONS AND PRICING SET HEREIN ARE FIRM FOR THE LIFE OF THE CONTRACT.</p> <p>RENEWAL: THIS CONTRACT MAY BE RENEWED UPON THE MUTUAL WRITTEN CONSENT OF THE SPENDING UNIT AND VENDOR,</p>						

RECEIVED

NOV 30 A 10:24

PURCHASING DIVISION
 STATE OF WV

SEE REVERSE SIDE FOR TERMS AND CONDITIONS

SIGNATURE <i>Michael R. Hall</i>	MICHAEL R. HALL	TELEPHONE 800-279-3863	DATE 11/29/11
TITLE President	FEIN 48-1106998	ADDRESS CHANGES TO BE NOTED ABOVE	

WHEN RESPONDING TO RFQ, INSERT NAME AND ADDRESS IN SPACE ABOVE LABELED 'VENDOR'

GENERAL TERMS & CONDITIONS REQUEST FOR QUOTATION (RFQ) AND REQUEST FOR PROPOSAL (RFP)

1. Awards will be made in the best interest of the State of West Virginia.
 2. The State may accept or reject in part, or in whole, any bid.
 3. Prior to any award, the apparent successful vendor must be properly registered with the Purchasing Division and have paid the required \$125 fee.
 4. All services performed or goods delivered under State Purchase Order/Contracts are to be continued for the term of the Purchase Order/Contracts, contingent upon funds being appropriated by the Legislature or otherwise being made available. In the event funds are not appropriated or otherwise available for these services or goods this Purchase Order/Contract becomes void and of no effect after June 30.
 5. Payment may only be made after the delivery and acceptance of goods or services.
 6. Interest may be paid for late payment in accordance with the *West Virginia Code*.
 7. Vendor preference will be granted upon written request in accordance with the *West Virginia Code*.
 8. The State of West Virginia is exempt from federal and state taxes and will not pay or reimburse such taxes.
 9. The Director of Purchasing may cancel any Purchase Order/Contract upon 30 days written notice to the seller.
 10. The laws of the State of West Virginia and the *Legislative Rules* of the Purchasing Division shall govern the purchasing process.
 11. Any reference to automatic renewal is hereby deleted. The Contract may be renewed only upon mutual written agreement of the parties.
 12. **BANKRUPTCY:** In the event the vendor/contractor files for bankruptcy protection, the State may deem this contract null and void, and terminate such contract without further order.
 13. **HIPAA BUSINESS ASSOCIATE ADDENDUM:** The West Virginia State Government HIPAA Business Associate Addendum (BAA), approved by the Attorney General, is available online at www.state.wv.us/admin/purchase/vrc/hipaa.html and is hereby made part of the agreement provided that the Agency meets the definition of a Cover Entity (45 CFR §160.103) and will be disclosing Protected Health Information (45 CFR §160.103) to the vendor.
 14. **CONFIDENTIALITY:** The vendor agrees that he or she will not disclose to anyone, directly or indirectly, any such personally identifiable information or other confidential information gained from the agency, unless the individual who is the subject of the information consents to the disclosure in writing or the disclosure is made pursuant to the agency's policies, procedures, and rules. Vendor further agrees to comply with the Confidentiality Policies and Information Security Accountability Requirements, set forth in <http://www.state.wv.us/admin/purchase/privacy/noticeConfidentiality.pdf>.
 15. **LICENSING:** Vendors must be licensed and in good standing in accordance with any and all state and local laws and requirements by any state or local agency of West Virginia, including, but not limited to, the West Virginia Secretary of State's Office, the West Virginia Tax Department, and the West Virginia Insurance Commission. The vendor must provide all necessary releases to obtain information to enable the director or spending unit to verify that the vendor is licensed and in good standing with the above entities.
 16. **ANTITRUST:** In submitting a bid to any agency for the State of West Virginia, the bidder offers and agrees that if the bid is accepted the bidder will convey, sell, assign or transfer to the State of West Virginia all rights, title and interest in and to all causes of action it may now or hereafter acquire under the antitrust laws of the United States and the State of West Virginia for price fixing and/or unreasonable restraints of trade relating to the particular commodities or services purchased or acquired by the State of West Virginia. Such assignment shall be made and become effective at the time the purchasing agency tenders the initial payment to the bidder.
- I certify that this bid is made without prior understanding, agreement, or connection with any corporation, firm, limited liability company, partnership, or person or entity submitting a bid for the same material, supplies, equipment or services and is in all respects fair and without collusion or fraud. I further certify that I am authorized to sign the certification on behalf of the bidder or this bid.

INSTRUCTIONS TO BIDDERS

1. Use the quotation forms provided by the Purchasing Division. Complete all sections of the quotation form.
2. Items offered must be in compliance with the specifications. Any deviation from the specifications must be clearly indicated by the bidder. Alternates offered by the bidder as **EQUAL** to the specifications must be clearly defined. A bidder offering an alternate should attach complete specifications and literature to the bid. The Purchasing Division may waive minor deviations to specifications.
3. Unit prices shall prevail in case of discrepancy. All quotations are considered F.O.B. destination unless alternate shipping terms are clearly identified in the quotation.
4. All quotations must be delivered by the bidder to the office listed below prior to the date and time of the bid opening. Failure of the bidder to deliver the quotations on time will result in bid disqualifications: Department of Administration, Purchasing Division, 2019 Washington Street East, P.O. Box 50130, Charleston, WV 25305-0130
5. Communication during the solicitation, bid, evaluation or award periods, except through the Purchasing Division, is strictly prohibited (W.Va. C.S.R. §148-1-6.6).



State of West Virginia
 Department of Administration
 Purchasing Division
 2019 Washington Street East
 Post Office Box 50130
 Charleston, WV 25305-0130

Request for Quotation

RFQ NUMBER
8512C2026

PAGE
2

ADDRESS CORRESPONDENCE TO ATTENTION OF:
PAUL REYNOLDS
304-558-0468

VENDOR

RFQ COPY
 TYPE NAME/ADDRESS HERE

SHIP TO

DIVISION OF HIGHWAYS
 VARIOUS LOCALES AS INDICATED
 BY ORDER

DATE PRINTED	TERMS OF SALE	SHIP VIA	F.O.B.	FREIGHT TERMS
11/10/2011				

BID OPENING DATE: **11/30/2011** BID OPENING TIME **01:30PM**

LINE	QUANTITY	UOP	CAT. NO.	ITEM NUMBER	UNIT PRICE	AMOUNT
<p>SUBMITTED TO THE DIRECTOR OF PURCHASING THIRTY (30) DAYS PRIOR TO THE EXPIRATION DATE. SUCH RENEWAL SHALL BE IN ACCORDANCE WITH THE TERMS AND CONDITIONS OF THE ORIGINAL CONTRACT AND SHALL BE LIMITED TO TWO (2) ONE (1) YEAR PERIODS.</p> <p>CANCELLATION: THE DIRECTOR OF PURCHASING RESERVES THE RIGHT TO CANCEL THIS CONTRACT IMMEDIATELY UPON WRITTEN NOTICE TO THE VENDOR IF THE COMMODITIES AND/OR SERVICES SUPPLIED ARE OF AN INFERIOR QUALITY OR DO NOT CONFORM TO THE SPECIFICATIONS OF THE BID AND CONTRACT HEREIN.</p> <p>OPEN MARKET CLAUSE: THE DIRECTOR OF PURCHASING MAY AUTHORIZE A SPENDING UNIT TO PURCHASE ON THE OPEN MARKET, WITHOUT THE FILING OF A REQUISITION OR COST ESTIMATE, ITEMS SPECIFIED ON THIS CONTRACT FOR IMMEDIATE DELIVERY IN EMERGENCIES DUE TO UNFORESEEN CAUSES (INCLUDING BUT NOT LIMITED TO DELAYS IN TRANSPORTATION OR AN UNANTICIPATED INCREASE IN THE VOLUME OF WORK.)</p> <p>QUANTITIES: QUANTITIES LISTED IN THE REQUISITION ARE APPROXIMATIONS ONLY, BASED ON ESTIMATES SUPPLIED BY THE STATE SPENDING UNIT. IT IS UNDERSTOOD AND AGREED THAT THE CONTRACT SHALL COVER THE QUANTITIES ACTUALLY ORDERED FOR DELIVERY DURING THE TERM OF THE CONTRACT, WHETHER MORE OR LESS THAN THE QUANTITIES SHOWN.</p> <p>ORDERING PROCEDURE: SPENDING UNIT(S) SHALL ISSUE A WRITTEN STATE CONTRACT ORDER (FORM NUMBER WV-39) TO THE VENDOR FOR COMMODITIES COVERED BY THIS CONTRACT. THE ORIGINAL COPY OF THE WV-39 SHALL BE MAILED TO THE VENDOR AS AUTHORIZATION FOR SHIPMENT, A SECOND COPY MAILED TO THE PURCHASING DIVISION, AND A THIRD COPY RETAINED BY THE SPENDING UNIT.</p>						

SEE REVERSE SIDE FOR TERMS AND CONDITIONS

SIGNATURE <i>Michael R. Hall</i>	Michael R. Hall	TELEPHONE 800-279-3863	DATE 11/29/11
TITLE President	FEIN 48-1106998	ADDRESS CHANGES TO BE NOTED ABOVE	

WHEN RESPONDING TO RFQ, INSERT NAME AND ADDRESS IN SPACE ABOVE LABELED 'VENDOR'



State of West Virginia
 Department of Administration
 Purchasing Division
 2019 Washington Street East
 Post Office Box 50130
 Charleston, WV 25305-0130

Request for Quotation

RFQ NUMBER
8512C2026

PAGE
3

ADDRESS CORRESPONDENCE TO ATTENTION OF:
PAUL REYNOLDS
304-558-0468

VENDOR

RFQ COPY
 TYPE NAME/ADDRESS HERE

SHIP TO

DIVISION OF HIGHWAYS
 VARIOUS LOCALES AS INDICATED
 BY ORDER

DATE PRINTED	TERMS OF SALE	SHIP VIA	F.O.B.	FREIGHT TERMS
11/10/2011				

BID OPENING DATE: **11/30/2011** BID OPENING TIME **01:30PM**

LINE	QUANTITY	UOP	CAT NO	ITEM NUMBER	UNIT PRICE	AMOUNT
<p>BANKRUPTCY: IN THE EVENT THE VENDOR/CONTRACTOR FILES FOR BANKRUPTCY-PROTECTION, THE STATE MAY DEEM THE CONTRACT NULL AND VOID, AND TERMINATE SUCH CONTRACT WITHOUT FURTHER ORDER.</p> <p>THE TERMS AND CONDITIONS CONTAINED IN THIS CONTRACT SHALL SUPERSEDE ANY AND ALL SUBSEQUENT TERMS AND CONDITIONS WHICH MAY APPEAR ON ANY ATTACHED PRINTED DOCUMENTS SUCH AS PRICE LISTS, ORDER FORMS, SALES AGREEMENTS OR MAINTENANCE AGREEMENTS, INCLUDING ANY ELECTRONIC MEDIUM SUCH AS CD-ROM.</p> <p>REV. 05/26/2009</p> <p>EXHIBIT 4</p> <p>LOCAL GOVERNMENT BODIES: UNLESS THE VENDOR INDICATES IN THE BID HIS REFUSAL TO EXTEND THE PRICES, TERMS, AND CONDITIONS OF THE BID TO COUNTY, SCHOOL, MUNICIPAL AND OTHER LOCAL GOVERNMENT BODIES, THE BID SHALL EXTEND TO POLITICAL SUBDIVISIONS OF THE STATE OF WEST VIRGINIA. IF THE VENDOR DOES NOT WISH TO EXTEND THE PRICES, TERMS, AND CONDITIONS OF THE BID TO ALL POLITICAL SUBDIVISIONS OF THE STATE, THE VENDOR MUST CLEARLY INDICATE SUCH REFUSAL IN HIS BID. SUCH REFUSAL SHALL NOT PREJUDICE THE AWARD OF THIS CONTRACT IN ANY MANNER.</p> <p>REV. 3/88</p> <p>PURCHASING CARD ACCEPTANCE: THE STATE OF WEST VIRGINIA CURRENTLY UTILIZES A VISA PURCHASING CARD PROGRAM WHICH IS ISSUED THROUGH A BANK. THE SUCCESSFUL VENDOR MUST ACCEPT THE STATE OF WEST VIRGINIA VISA PURCHASING CARD FOR PAYMENT OF ALL ORDERS PLACED BY ANY STATE AGENCY AS A CONDITION OF AWARD.</p>						

SEE REVERSE SIDE FOR TERMS AND CONDITIONS

SIGNATURE <i>Michael R. Hall</i>	Michael R. Hall	TELEPHONE 800-279-3863	DATE 11/29/11
TITLE President	FEIN 48-1106998	ADDRESS CHANGES TO BE NOTED ABOVE	

WHEN RESPONDING TO RFQ, INSERT NAME AND ADDRESS IN SPACE ABOVE LABELED 'VENDOR'



State of West Virginia
 Department of Administration
 Purchasing Division
 2019 Washington Street East
 Post Office Box 50130
 Charleston, WV 25305-0130

Request for Quotation

RFQ NUMBER
8512C2026

PAGE
4

ADDRESS CORRESPONDENCE TO ATTENTION OF:
**PAUL REYNOLDS
 304-558-0468**

VENDOR

RFQ COPY
 TYPE NAME/ADDRESS HERE

SHIP TO

DIVISION OF HIGHWAYS
 VARIOUS LOCALES AS INDICATED
 BY ORDER

DATE PRINTED 11/10/2011	TERMS OF SALE	SHIP VIA	F.O.B.	FREIGHT TERMS
-----------------------------------	---------------	----------	--------	---------------

BID OPENING DATE: **11/30/2011** BID OPENING TIME **01:30PM**

LINE	QUANTITY	UOP	CAT NO.	ITEM NUMBER	UNIT PRICE	AMOUNT
<p>NOTICE</p> <p>A SIGNED BID MUST BE SUBMITTED TO:</p> <p>DEPARTMENT OF ADMINISTRATION PURCHASING DIVISION BUILDING 15 2019 WASHINGTON STREET, EAST CHARLESTON, WV 25305-0130</p> <p>THE BID SHOULD CONTAIN THIS INFORMATION ON THE FACE OF THE ENVELOPE OR THE BID MAY NOT BE CONSIDERED:</p> <p>SEALED BID</p> <p>BUYER: PAUL REYNOLDS FILE 33</p> <p>RFQ. NO.: 8512C2026</p> <p>BID OPENING DATE: 11/30/2011</p> <p>BID OPENING TIME: 1:30 P.M.</p> <p>PLEASE PROVIDE A FAX NUMBER IN CASE IT IS NECESSARY TO CONTACT YOU REGARDING YOUR BID: 800-289-1903</p> <p>-----</p> <p>CONTACT PERSON (PLEASE PRINT CLEARLY): Gary Piel</p> <p>-----</p>						

SEE REVERSE SIDE FOR TERMS AND CONDITIONS

SIGNATURE <i>Michael R. Hall</i>	Michael R. Hall	TELEPHONE 800-279-3863	DATE 11/29/11
TITLE President	FEIN 48-1106998	ADDRESS CHANGES TO BE NOTED ABOVE	

WHEN RESPONDING TO RFQ, INSERT NAME AND ADDRESS IN SPACE ABOVE LABELED 'VENDOR'

**Specifications for Fluorescent Lime-Yellow
ANSI/ISEA 107
Class 2 High-Visibility Vests, Class 3 High-Visibility Vests, and Class 3
High-Visibility Pullovers with Contrast Trim**

**Specifications for Fluorescent Red-Orange
ANSI/ISEA 107
Class 2 High-Visibility Low Cost "Adopt-A-Highway" Vests**

Purpose: To establish an open end contract to provide the West Virginia Division of Highways with safety vests and pullover garments.

1.0 DEFINITIONS

- A. The "Agency" shall be defined as the West Virginia Division of Highways
- B. The "Vendor" shall be defined as the successful bidder.
- C. The "Contract" shall be defined as the binding agreement that is entered into between the State of West Virginia and the Vendor to provide the services as herein specified.
- D. "Release Order" shall be defined as order placed against the Contract by the Agency.
- E. Mandatory Requirements: The terms "must", "will", "shall", "minimum", "maximum", or "is/are required" identify a mandatory item or factor. Decisions regarding compliance with any mandatory requirements shall be at the sole discretion of the State. The state reserves the right to waive minor irregularities in bids or specifications in accordance with section 148-1-4(F) of the West Virginia Legislative Rules and Regulations.
- F. "ANSI-107". All references to "ANSI-107" herein shall be interpreted as referencing the ANSI/ISEA (American National Standards Institute / International Safety Equipment Association) 107 American National Standards for High-Visibility Safety Apparel and Headwear, latest version as of the Contract advertising date.
- G. "Accredited Laboratory". All references to "Accredited Laboratory" contained herein shall be defined as a laboratory meeting the definition of "Accredited Laboratory" contained in ANSI-107 as defined per definition "F" above.

2.0 SCOPE OF WORK

The successful Vendor shall provide safety vests and pullover garments per the specifications herein.

2.1 General Material Requirements:

2.1.1: All garments must be manufactured using ANSI-107 accredited laboratory certified background and retroreflective component materials and meet all applicable ANSI-107 mandatory design requirements. The reflective material on all garments shall meet the requirements of ANSI-107 Photometric Performance Level 2. Component materials utilized to manufacture garments for this Contract shall be certified to ANSI-107 by a competent and qualified Accredited Laboratory. Accredited Laboratory certificates of compliance shall be provided.

2.1.2: The background material utilized for all garments shall have successfully passed the testing requirements contained within "NFPA (National Fire Protection Association) 701: Standard Methods of Fire Tests for Flame Propagation of Textiles and Films" (latest version as of the Contract advertising date)

2.1.3: With the exception of the "Adopt-A-Highway" vests, the background material and contrast striping background material used to manufacture all vests and pullovers supplied as part of this Contract shall be a mesh style material meeting the following specifications:

2.1.3.1: Background Material:

Yarn	70d Bright Trilobal Polyester	
Color	Fluorescent lime-yellow	
		Test Method
Count	Courses 30 +/- 2 Wales 40 +/- 2	FTM 5050
Weight	2.7 oz. +/- 0.5%	FTM 5041

The mesh hole size and spacing used for this material shall be identical to Style #3500 mesh as manufactured by Performance Textiles, Inc. of Greensboro, NC.

2.1.3.2: Contrast Striping Background Material:

Yarn	70d Bright Trilobal Polyester	
Color	Fluorescent Red-Orange	
		Test Method
Count	Courses 30 +/- 2 Wales 40 +/- 2	FTM 5050
Weight	2.7 oz. +/- 0.5%	FTM 5041

The mesh hole size and spacing used for this material shall be identical to Style #3500 mesh as manufactured by Performance Textiles, Inc. of Greensboro, NC.

2.1.4: Except as noted otherwise herein, all exposed vest edges shall be bound with grey nylon tricot or material identical to the background material of the vest. The same requirement shall apply to the neck of the pullover garment. Exposed edges of non-woven polyester vests, if used for the "Adopt-A-Highway" vests, shall not be required to be bound. Plastic type bindings or borders are not acceptable.

2.1.5: The retroreflective striping materials used to manufacture all garments supplied as part of this Contract shall be two (2) inches wide.

2.1.6: With the exception of the "Adopt-A-Highway" vests, the retroreflective striping used on all garments supplied as part of this Contract shall be a sewn on (non-heat applied) glass bead material and shall meet the following specification in addition to meeting all other applicable requirements previously described:

Backing Material:	Cotton – Polyester blend
Reflected color:	White
Daytime Color:	Silver or White
Initial Average RA*:	500
Minimum RA*:	330
Washing Cycles**:	30
Dry Cleaning Cycles:	0

*Retroreflective performance data shall be based on testing new product and measurements at +5.0° entrance and 0.2° observation angles. The coefficient of retroreflection (RA, in cd/lux/m²) shall be measured by methods based on either ASTM E809-08 and E810-03 (RA) or CIE 54.2:2001 (R')

**ISO 6330 Method 2A at 60 °C (140 °F) and RA ≥ 100 (home wash). Home Wash shall be defined as follows: Use of a top or front loading consumer type home washing machine with a consumer detergent at moderate water temperatures (up to 60 °C, 140 °F). Tumble dry low. Cool iron (110 °C (230 °F))

2.1.7: A retroreflective logo made up of the letters "WVDOH" shall be incorporated into vests/pullovers indicated as requiring such in the Bid Schedule. The "WVDOH" lettering shall be made up of individual retroreflective 3 inch tall letters. The font style used shall be 3 inch Series C Highway Font. A scaled drawing of this logo is included as part of these specifications. This lettering will be made available electronically in .jpg, .bmp, or vectorized format upon request by contacting Bruce Miller of the WVDOH Traffic Engineering Division at 304-558-9454 or bruce.f.miller@wv.gov .

2.1.7.1: The "WVDOH" logo placement shall be identical on all garments requiring this logo. Vertically, the logo shall be placed such that there is a 1/2" (+ 1/4" / - 0") edge to edge clearance between the top of the lettering and the bottom of the horizontal contrast stripe. Horizontally, the logo shall be centered on the back of the garment.

2.1.7.2: All garments including a retroreflective logo shall be in full compliance with the ANSI-107 square inches of background material requirements after the logo is applied. The area of the logo shall not be counted towards meeting the ANSI-107 square inches of retroreflective material requirements.

2.1.7.3: The retroreflective material used for the retroreflective logo for all garments requiring such as part of this Contract shall be a heat applied material and shall meet the Initial Average RA and Minimum RA requirements of the specification contained within 2.1.6. The minimum number of washing cycles shall be 25. The material shall also have the same Reflected color and Daytime Color as the retroreflective striping material.

2.1.8: Per ANSI-107, all garments shall include a label including the following information:

- a. Manufacturer
- b. ANSI/ISEA 107-XXXX ("XXXX" dependent on the applicable version of the ANSI/ISEA-107 specification as of the Contract advertising date)
- c. Fabric type
- d. Model #
- e. Size
- f. Pictogram showing garment class and retroreflectivity level
- g. Care guide and maximum number of cycles

Label example:

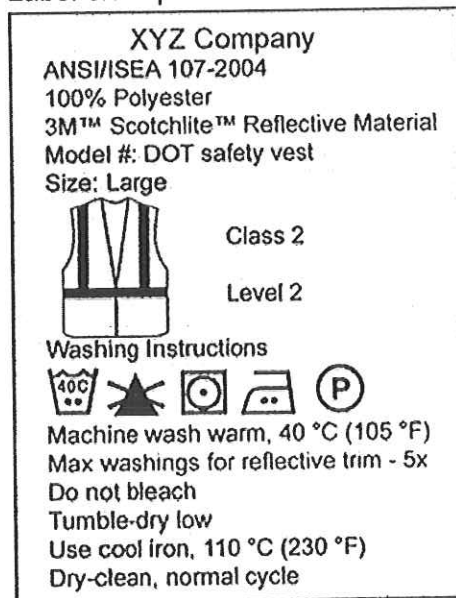

2.1.9: With the exception of the "Adopt-A-Highway" vests, all vests shall be manufactured with a front non-conductive zipper closure. This requirement shall be optional for "Adopt-A-Highway" vests.

2.1.10: With the exception of "Adopt-A-Highway" vests, all garments shall be manufactured according to the following sizing chart and shall be available in all of the sizes listed:

garment size	chest measurement
Medium	42"-44"
Large	46"-48"
X-Large	50"-52"
2X-Large	54"-56"
3X-Large	58"-60"
4X-Large	62"-64"
5X-Large	66"-68"
6X-Large	70"-72"
7X-Large	74"-76"
8X-Large	78"-80"

2.1.11: The manufacturer shall store, prepare, handle, and apply all garment fabrics and retroreflective materials fully in accordance with the garment fabric and retroreflective material supplier's recommendations. The manufacturer shall be responsible for verifying the compatibility of the garment and retroreflective materials to be used together.

2.1.12: All garments shall be of quality workmanship, comfortable to wear, and shall be free of ragged edges, surface blemishes, loose stitches, uneven seams or any defect which would make the vest unsuitable for their intended use.

2.1.13: All garments supplied under this Contract within any particular Section (Sections for the purpose of this Contract are defined under Section 5.1.1) shall vary only in size and presence of the specified lettering (when applicable). All other parameters, such as the specific type background material and reflective striping, shall be the same for all of the garments within the Section.

2.1.14: With the exception of the "Adopt-A-Highway" vests, all reflective striping for all garments supplied under this Contract shall be sewn to and applied over a Fluorescent Red-Orange contrast striping background material specified under 2.1.3.2. The edges of this material shall be folded or hemmed. The contrast striping background material shall measure 4-1/2" (+/- 1/8") wide after folding or hemming.

2.2: Manufacturing requirements for Class 2 Vests (does not include "Adopt-A-Highway" vests): In addition to any applicable requirements contained within Section 2.1, all Class 2 vests (does not include "Adopt-A-Highway" vests) shall be manufactured in accordance with the following:

2.2.1: One horizontal, 360 degree contrast stripe shall encircle the torso, and one vertical contrast stripe shall join the horizontal stripe from the front to the back over each shoulder. The horizontal contrast stripe shall be placed such that the bottom edge is approximately 6-1/2 inches (+/- 1/2 inch) above the bottom of the vest. Each vertical contrast stripe shall be placed halfway (+ / - 1/2 inch) between the neck opening and the outside of the shoulder.

2.2.2: These vests shall measure a minimum of 18 inches at the shoulder (outside of shoulder straight across to outside of shoulder) and shall be a minimum of 25 inches in length (measured from the top of the back of the neck opening).

2.2.3: The bottom of the "V" opening in the front of the vest (as measured along the vertical centerline from the top of the back of the neck opening to the top of the zipper) shall measure 11" (+ / - 1/2").

2.3: Manufacturing requirements for Class 3 Vests. In addition to any applicable requirements contained within Section 2.1, all Class 3 vests shall be manufactured in accordance with the following:

2.3.1: One horizontal, 360 degree contrast stripe shall encircle the torso, and one vertical contrast stripe shall join the horizontal stripe from the front to the back over each shoulder. The horizontal stripe shall be placed such that the bottom edge is approximately 6-1/2 inches (+/- 1/2 inch) above the bottom of the vest. Each vertical contrast stripe shall be placed halfway (+ / - 1/2 inch) between the neck opening and the outside of the shoulder. One contrast stripe shall completely encircle each sleeve between the bottom of the sleeve and the shoulder, and shall be placed such that the bottom edge of the contrast stripe is 2 inches (+/- 1/2 inch) from the end of the sleeve.

2.3.2: These vests shall measure a minimum of 18 inches at the shoulder (outside of shoulder straight across to outside of shoulder) and shall be a minimum of 25 inches in length (measured from the top of the back of the neck opening).

2.3.3: Sleeves shall measure 12 inches (+/- 1/2 inch). The length may be increased within reason to meet the ANSI-107 requirements if needed.

2.3.4: The bottom of the "V" opening in the front of the vest (as measured along the vertical centerline from the top of the back of the neck opening to the top of the zipper) shall measure 11" (+ / - 1/2").

2.4: Manufacturing requirements for Class 3 Pullovers. In addition to any applicable requirements contained within Section 2.1, all Class 3 Pullovers shall be manufactured in accordance with the following:

2.4.1: One horizontal, 360 degree contrast stripe shall encircle the torso, and one vertical contrast stripe shall join the horizontal stripe from the front to the back over each shoulder. The horizontal stripe shall be placed such that the bottom edge is approximately 6-1/2 inches (+/- 1/2 inch) above the bottom of the vest. Each vertical contrast stripe shall be placed halfway (+ / - 1/2 inch) between the neck opening and the outside of the shoulder. One contrast stripe shall completely encircle each sleeve between the bottom of the sleeve and the shoulder, and shall be placed such that the bottom edge of the contrast stripe is 2 inches (+/- 1/2 inch) from the end of the sleeve.

2.4.2: These pullovers shall measure a minimum of 18 inches at the shoulder (outside of shoulder straight across to outside of shoulder) and shall be a minimum of 25 inches in length (measured from the top of the back of the neck opening).

2.4.3: Sleeves shall measure 12 inches (+/- 1/2 inch). The length may be increased within reason to meet the ANSI-107 requirements if needed.

2.4.4: The bottom of the "V" neck opening in the front of the pullover (as measured along the vertical centerline from the top of the neck of the pullover in the back) shall measure 11" (+ / - 1/2").

2.4.5: The bottom edge and sleeve ends of these pullovers shall be elastic surged to hold the bottom and ends against the arms and waist. The elastic shall not, however, cause discomfort from being overly tight.

2.5: Manufacturing requirements for "Adopt-A-Highway" vests. In addition to any applicable requirements contained within Section 2.1, all "Adopt-A-Highway" vests shall be manufactured in accordance with the following:

2.5.1: The background material used to manufacture all "Adopt-A-Highway" vests supplied as part of this Contract shall be of the manufacturer's choosing. However, the material utilized shall have a maximum weight of 3.7 oz per sq yd. The color of the "Adopt-A-Highway" vests shall be Fluorescent red-orange.

2.5.2: Either sewn-on or heat applied retroreflective striping may be utilized for "Adopt-A-Highway" vests.

2.5.3: The striping pattern utilized shall be as shown below. One horizontal, 360 degree stripe shall encircle the torso. One vertical stripe shall join the torso stripe from the front to the back over each shoulder. The minimum clear distance on the back of the vests between the two vertical stripes shall be ten-inches (10").

2.5.4: These vests shall be manufactured to cover a range of sizes by utilizing side adjustments as shown below. The method of side adjustment shall be hook and loop type, and shall utilize two continuous horizontal one-inch (minimum) wide strips on each side, and shall be designed to provide the ability to adjust continuously, not incrementally, over the range of sizes provided below.

2.5.5: Manufacturing Detail Drawing:

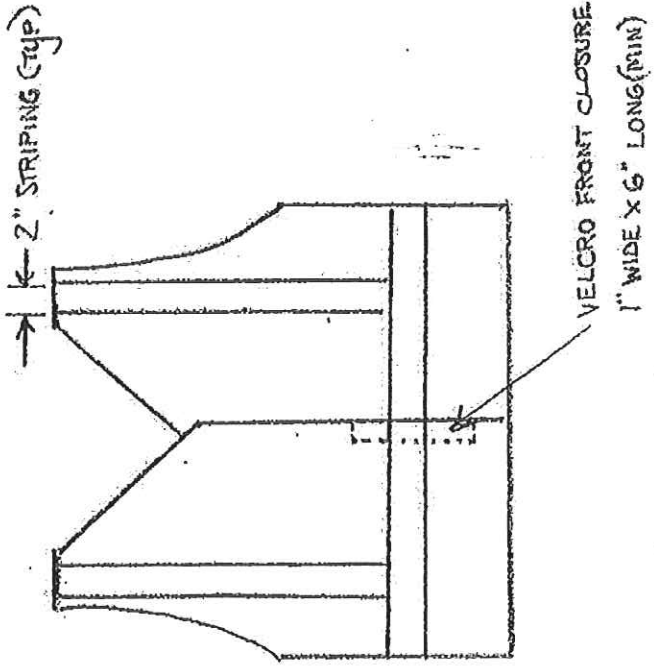

FRONT VIEW

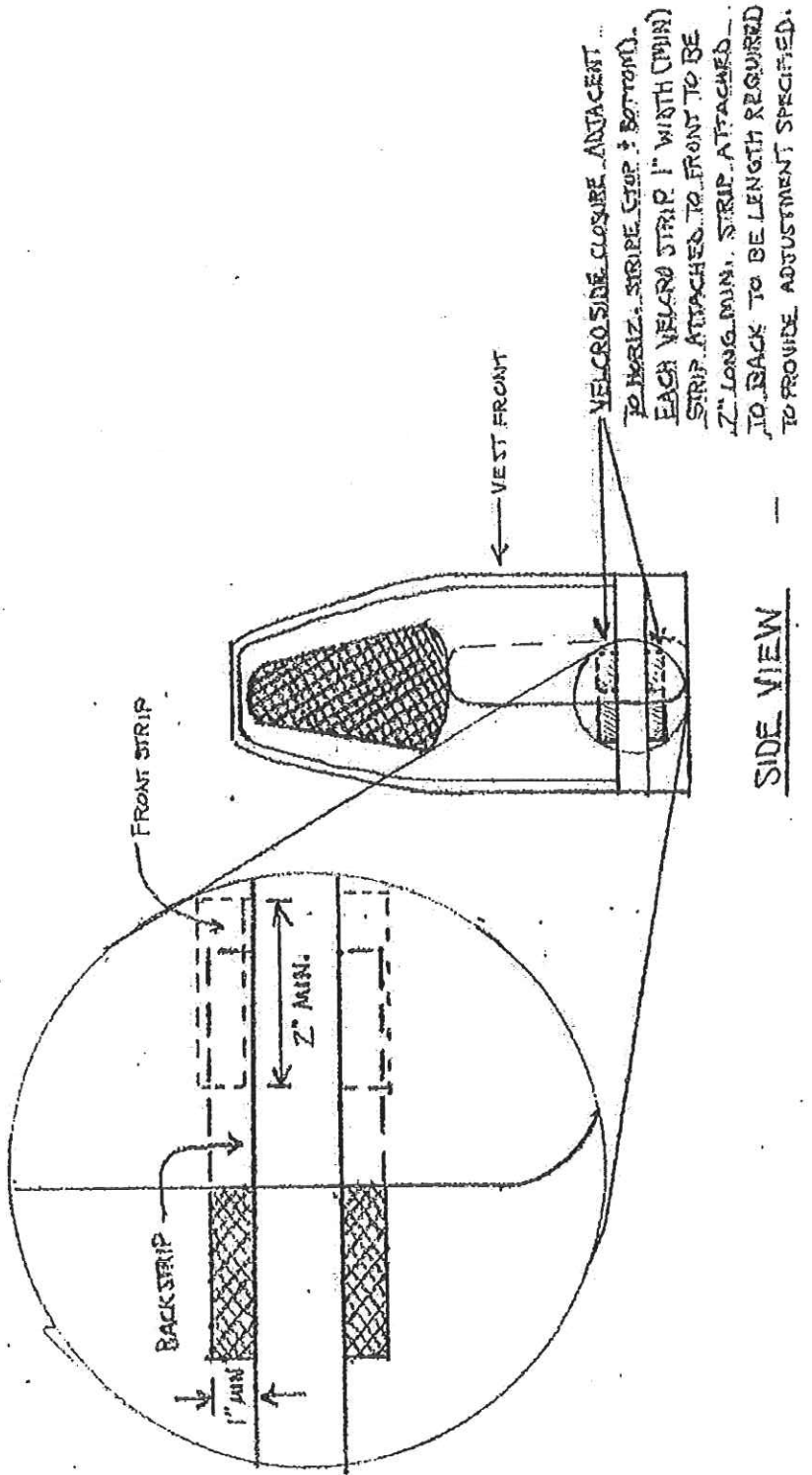

SIDE VIEW

2.5.6: "Adopt-A-Highway" vests shall be manufactured according to the following sizing chart and shall be available in all of the sizes listed:

Size	Chest Measurement
M-2XL	42" - 56"
3XL-4XL	58" - 64"

2.5.7: These vests shall measure a minimum of 16 inches at the shoulder (outside of shoulder straight across to outside of shoulder) and shall be a minimum of 24 inches in length (measured from the top of the back of the neck opening).

2.5.8: The front closure provided for these vests may be vertical hook and loop as shown in Section 2.5.5 or may be manufactured with a front non-conductive zipper closure.

2.5.9: Logos: Black silk screened lettering shall be incorporated into the vests indicated as requiring such on the Bid Schedule. The lettering shall be made up of 1.5 inch tall letters. The font style used shall be Series B Highway Font. The text on these vests shall read "ADOPT-A-HWY". This text shall be identical in size, shape, and appearance to the drawing included as part of these specifications. This lettering will be made available electronically in .jpg, .bmp, or vectorized format upon request by contacting Bruce Miller of the WVDOH Traffic Engineering Division at 304-558-9454 or bruce.f.miller@wv.gov.

2.5.9.1: Lettering shall be screened on the back of the vests, such that the lettering is centered horizontally between the two vertical shoulder stripes. Vertically, the lettering shall be placed such that there is a 1 inch (+ ¼" / - 0") clearance between the bottom of the letters and the top of the horizontal reflective stripe. All silk screened text provided on vests supplied as part of this Contract shall be free of rough edges, smearing, running, splotches, or other visual defects.

2.5.9.2: These vests shall be in full compliance with the ANSI-107 square inches of background material requirement after the above specified lettering is applied.

2.5.10: The bottom of the "V" opening in the front of the vest (as measured along the vertical centerline from the top of the back of the neck opening to the bottom of the "V") shall measure 11" (+ / - ½"). If a zipper is used for the closure, this measurement shall be made to the top of the zipper.

3.0 ORDERING AND INVOICING

3.1 Release Orders

3.1.1 For all orders, the Agency will issue to the Vendor a WV-35 Release Order. Issuance of the Release Order shall contain the type of merchandise to be purchased and shall serve as the authorization to process the order.

3.1.2 Release Orders shall be delivered in full within the applicable specified time frame per Section 4.1.1. If the Vendor is unable to deliver in full within the applicable time frame, the Vendor shall be subject to a daily (per Calendar Day) penalty at the purchasing organizations discretion for each Calendar Day beyond sixty (60) Calendar Days ARO until the order is received in full. This penalty shall be assessed by subtracting the penalty from the original total value of the Release Order. The penalty shall not exceed the original total amount of the Release Order. The penalty shall be calculated based on the Table shown at the following address:

<http://www.transportation.wv.gov/highways/contractadmin/specifications/Pages/LiquidDatedDamages.aspx>

The original total amount of the Release Order shall be substituted for the "Original Contract Amount" when using this Table.

3.1.3 There shall be no minimum order size requirement for any Item on this Contract.

3.1.4 Delivery is an integral part of this contract and failure to comply will be cause to initiate a WV-82, Vendor Performance Form. This form will officially notify the West Virginia Division of Purchasing and the Vendor of unsatisfactory performance in the execution of this Contract and the requirements herein.

3.2 Payment

3.2.1 The State of West Virginia currently utilizes a VISA purchasing card program which is issued through a local bank. The Vendor must accept the State of West Virginia purchasing card for payment of all orders placed against this Contract.

3.2.2 The Vendor must supply a credit card receipt, sales receipt, or cash register receipt. Charges must not be applied until merchandise is received in full by the Agency.

4.0 DELIVERY

4.1: Delivery Deadlines

4.1.1: All Release Orders off of this Contract which DO contain size 5XL or larger garments shall be delivered within 45 days A.R.O. This 45 day delivery deadline shall apply to the entire order, including garments sized Medium to 4XL. All Release Orders off of this Contract which DO NOT contain size 5XL or larger garments shall be delivered within 30 days A.R.O.

4.2: Delivery Locations

4.2.1: Typically, delivery locations will be to, but shall not be limited to, the locations of the ten WVDOH District Headquarters. The cities in which the District Headquarters are located are Charleston, Huntington, Parkersburg, Clarksburg, Burlington, Moundsville, Weston, Elkins, Lewisburg, and Princeton.

4.3: Delivery Notification

4.3.1: If the Release Order includes a contact name and phone number for advance notification of delivery, the Vendor shall notify the contact a minimum of one (1) working day prior to delivery.

4.4: Garments shall be packaged in plastic bags with one garment per bag and one size per shipping carton.

5.0 AWARD

5.1: Contract Sections

5.1.1: For evaluation and award purposes, this Contract shall be divided into four (4) sections. Each Section shall be evaluated independently and awarded as such. If it is determined that award should be made to one Vendor for two (2) or more Sections, those Sections will be combined into one Contract.

4.1.1.1: Section I shall include Class 2 High-Visibility Vests.

4.1.1.2: Section II shall include items Class 3 High-Visibility Vests.

4.1.1.3: Section III shall include items Class 3 High-Visibility Pullovers.

4.1.1.4: Section IV shall include items Class 2 High-Visibility Low Cost "Adopt-A-Highway" Vests.

5.2: Evaluation Procedure – Bids returned for each of the Sections defined above shall be evaluated as follows:

5.2.1: Based on pricing and taking into account any requested in-state Vendor preference, the lowest three bids for each Section shall be determined.

5.2.2: The WVDOH will request that each of the three lowest bidders for each Section provide to the WVDOH the following for review. Requests for the items described below will be documented by sending the request by email or fax to an email address or fax number of a contact provided by the Vendor. Each Vendor shall have fourteen (14) Calendar Days to return the items described below to the WVDOH for review. If not received within fourteen (14) Calendar Days, the Vendor's bid will be disqualified. The items described below shall be mailed to the following address:

WVDOH-Traffic Engineering Division
Bldg 5, Room 550
1900 Kanawha Blvd. East
Charleston, WV 25305
ATTN: Bruce Miller

The following information should also be provided on a separate document along with the items described below:

- Vendor Name
- Requisition Number
- Bid Item Section(s) for which the items described below are being provided for

The items described below must be received by Mr. Bruce Miller of the WVDOH Traffic Engineering Division within the time frame previously described. The WVDOH will not be responsible if the items described below are not received by Mr. Bruce Miller within the time frame previously described due to any reason. The Vendor may contact Mr. Bruce Miller at bruce.f.miller@wv.gov in order to verify that the items described below have been received. It is recommended that the Vendor mail the items described below as soon as possible after the items have been requested in order to allow time for these items to be sent again if necessary and delivered prior to the deadline previously described (based on the date of the initial WVDOH request).

5.2.2.1: Sample garment – A sample of the garment to be provided by the Vendor shall be provided. Specific details of the garments to be provided are as follows:

5.2.2.1.1: Section I – Size Large vest with retroreflective logo. The logo shall not be required to read "WVDOH"; however, the logo shall be made only of the same material the Vendor intends to use for the "WVDOH" logo and shall be placed in the same general location as specified previously herein. All other characteristics of the vest shall be a completely accurate representation of the vests that the Vendor intends to supply if awarded a Contract for this Section.

5.2.2.1.2: Section II – Size Large vest with retroreflective logo. The logo shall not be required to read "WVDOH"; however, the logo shall be made only of the same material the Vendor intends to use for the "WVDOH" logo and shall be placed in the same general location as specified previously herein. All other characteristics of the vest shall be a completely accurate representation of the vests that the Vendor intends to supply if awarded a Contract for this Section.

5.2.2.1.3: Section III – Size Large pullover with retroreflective logo. The logo shall not be required to read "WVDOH"; however, the logo shall be made only of the same material the Vendor intends to use for the "WVDOH" logo and shall be placed in the same general location as specified previously herein. All other characteristics of the pullover shall be a completely accurate representation of the pullovers that the Vendor intends to supply if awarded a Contract for this Section.

5.2.2.1.4: Section IV – Size M-2XL vest with screened logo. The logo shall not be required to read "ADOPT-A-HWY"; however, the logo shall be silk screened in black using the same material the Vendor intends to use for the "ADOPT-A-HWY" logo and shall be placed in the same general location as specified previously herein. All other characteristics of the vest shall be a completely accurate representation of the vests that the Vendor intends to supply if awarded a Contract for this Section.

5.2.2.2: Accredited Laboratory ANSI-107 certificate of compliance for the background material to be used in manufacturing the garment.

5.2.2.3: Accredited Laboratory ANSI-107 Performance Level 2 certificate of compliance for the retroreflective striping material to be used in manufacturing the garment.

5.2.2.4: Accredited Laboratory ANSI-107 Performance Level 2 certificate of compliance for the retroreflective logo material to be used in manufacturing the garment (does not apply to Section IV garments).

5.2.2.5: "NFPA (National Fire Protection Association) 701: Standard Methods of Fire Tests for Flame Propagation of Textiles and Films" certificate of compliance for the background material to be used in manufacturing the garment.

5.2.2.6: Manufacturer self-certification for the completed garment. A separate certification shall be provided for each garment sample supplied. The content and format of this self-certification shall be as described in the ANSI-107 specification.

5.2.3: All sample garments and documentation will be reviewed for compliance with the Contract specifications. The results of these reviews will be documented.

5.2.4: If necessary, the WVDOH will request additional garment samples and certifications from additional Vendors in order to determine the Vendor within each Section that can provide the garments requested at the lowest price taking into account any requested in-state Vendor preferences.

5.3: The WVDOH reserves the right to not recommend award to any or all of the defined Sections of this Contract for any reason.

5.4: The Vendor must provide a bid for all items within each Section that the Vendor wishes to be considered for award. The Vendor's bid for any Section in which the Vendor does not provide pricing for every Item within that Section will not be considered for award.

BID SCHEDULE

The quantities listed below are not intended to represent actual expected quantities to be ordered. The quantities are based on known previous annual order quantities with the size ranges historically ordered in the smallest quantity normalized to a value of " 1 " and the quantities for the other size ranges adjusted accordingly based on previous order history ratios. The order histories which were used to determine the ratios used for creating the estimated quantities shown was based on the Items contained in Sections I and IV which included a logo (lettering on the back of the garment).

It is expected that items in Sections II and III will be ordered in relatively lower quantities than the items in Section I. Also, it is expected that the non-logo items will be ordered in lower quantities than the items requiring logos. However, note that no attempt is made to reflect this in the estimated quantities shown below.

Actual quantities will be determined by the needs of the user Agencies and may be increased or decreased.

ITEM	ESTIMATED QUANTITY	DESCRIPTION	UNIT COST	ITEM TOTAL COST
SECTION I - Class 2 High-Visibility Vests (does not include Adopt-A-Highway vests)				
1	42	Sizes M through 2XL with "WVDOH" logo SPECIFY QTY OF EACH SIZE M, L, XL, AND 2XL ON ORDER	11.78	494.76
2	5	Sizes 3XL through 4XL with "WVDOH" logo SPECIFY QTY OF EACH SIZE 3XL AND 4XL ON ORDER	11.78	58.90
3	2	Sizes 5XL through 6XL with "WVDOH" logo SPECIFY QTY OF EACH SIZE 5XL AND 6XL ON ORDER	11.78	23.56
4	1	Sizes 7XL through 8XL with "WVDOH" logo SPECIFY QTY OF EACH SIZE 7XL AND 8XL ON ORDER	11.78	11.78
5	42	Sizes M through 2XL without logo SPECIFY QTY OF EACH SIZE M, L, XL, AND 2XL ON ORDER (THIS ITEM IS NOT INTENDED FOR WVDOH ORDERS)	9.78	410.76
6	5	Sizes 3XL through 4XL without logo SPECIFY QTY OF EACH SIZE 3XL AND 4XL ON ORDER (THIS ITEM IS NOT INTENDED FOR WVDOH ORDERS)	9.78	48.90
7	2	Sizes 5XL through 6XL without logo SPECIFY QTY OF EACH SIZE 5XL AND 6XL ON ORDER (THIS ITEM IS NOT INTENDED FOR WVDOH ORDERS)	9.78	19.56
8	1	Sizes 7XL through 8XL without logo SPECIFY QTY OF EACH SIZE 7XL AND 8XL ON ORDER (THIS ITEM IS NOT INTENDED FOR WVDOH ORDERS)	9.78	9.78
SECTION TOTAL				1,078.00
SECTION II - Class 3 High-Visibility Vests				
9	42	Sizes M through 2XL with "WVDOH" logo SPECIFY QTY OF EACH SIZE M, L, XL, AND 2XL ON ORDER	17.40	730.80
10	5	Sizes 3XL through 4XL with "WVDOH" logo SPECIFY QTY OF EACH SIZE 3XL AND 4XL ON ORDER	17.40	87.00
11	2	Sizes 5XL through 6XL with "WVDOH" logo SPECIFY QTY OF EACH SIZE 5XL AND 6XL ON ORDER	17.40	34.80
12	1	Sizes 7XL through 8XL with "WVDOH" logo SPECIFY QTY OF EACH SIZE 7XL AND 8XL ON ORDER	17.40	17.40
13	42	Sizes M through 2XL without logo SPECIFY QTY OF EACH SIZE M, L, XL, AND 2XL ON ORDER (THIS ITEM IS NOT INTENDED FOR WVDOH ORDERS)	15.00	630.00
14	5	Sizes 3XL through 4XL without logo SPECIFY QTY OF EACH SIZE 3XL AND 4XL ON ORDER (THIS ITEM IS NOT INTENDED FOR WVDOH ORDERS)	15.00	75.00
15	2	Sizes 5XL through 6XL without logo SPECIFY QTY OF EACH SIZE 5XL AND 6XL ON ORDER (THIS ITEM IS NOT INTENDED FOR WVDOH ORDERS)	15.00	30.00
16	1	Sizes 7XL through 8XL without logo SPECIFY QTY OF EACH SIZE 7XL AND 8XL ON ORDER (THIS ITEM IS NOT INTENDED FOR WVDOH ORDERS)	15.00	15.00
SECTION TOTAL				1,620.00

WVDOH PERSONNEL

An online form is in place in order for District personnel to submit a documented report to the Traffic Engineering Division regarding issues associated with material orders. This form is intended to serve as a manner in which District personnel may quickly and easily submit a documented report to the Traffic Engineering Division regarding issues associated with ordering, delivery and receipt, quality, or order reconciliation issues associated with any of the materials ordered. This form may also be used to report issues with the installation or post-installation performance of materials. This form is located in the "Traffic" section of the WVDOH intranet site (Click on "Traffic" on the left side of the page, then click on "PO Contract Report" on the left side of the page). The direct address for the location of this form is <http://sharepoint.wv.gov/sites/dot/highways/traffic/pocontractreport/Pages/default.aspx>. Once the report is submitted, an email verification will be automatically sent and an email notice will be sent to the Traffic Engineering Division. All reports submitted will be responded to by the Traffic Engineering Division. The Traffic Engineering Division will work with the individual at the District submitting the report to obtain additional needed facts or documentation such as photos or product samples, and will contact and work with the Contract Vendor and Materials Division if needed in order to reconcile the issues in a manner acceptable to all parties if possible. Typically, as a final step to address reported issues, the Traffic Engineering Division will complete and submit a WV-82 Vendor Performance Form in order to officially document any issues and their outcome. The initial point of contact for any submitted reports is Bruce Miller. If you have any questions or would like to follow up on the status of a report that has been submitted, please contact Mr. Miller at 558-9454 or bruce.f.miller@wv.gov.

ITEM	ESTIMATED QUANTITY	DESCRIPTION	UNIT COST	ITEM TOTAL COST
SECTION III - Class 3 High-Visibility Pullovers				
17	42	Sizes M through 2XL with "WVDOH" logo SPECIFY QTY OF EACH SIZE M, L, XL, AND 2XL ON ORDER	16.95	711.90
18	5	Sizes 3XL through 4XL with "WVDOH" logo SPECIFY QTY OF EACH SIZE 3XL AND 4XL ON ORDER	16.95	84.75
19	2	Sizes 5XL through 6XL with "WVDOH" logo SPECIFY QTY OF EACH SIZE 5XL AND 6XL ON ORDER	16.95	33.90
20	1	Sizes 7XL through 8XL with "WVDOH" logo SPECIFY QTY OF EACH SIZE 7XL AND 8XL ON ORDER	16.95	16.95
21	42	Sizes M through 2XL without logo SPECIFY QTY OF EACH SIZE M, L, XL, AND 2XL ON ORDER (THIS ITEM IS NOT INTENDED FOR WVDOH ORDERS)	15.00	630.00
22	5	Sizes 3XL through 4XL without logo SPECIFY QTY OF EACH SIZE 3XL AND 4XL ON ORDER (THIS ITEM IS NOT INTENDED FOR WVDOH ORDERS)	15.00	75.00
23	2	Sizes 5XL through 6XL without logo SPECIFY QTY OF EACH SIZE 5XL AND 6XL ON ORDER (THIS ITEM IS NOT INTENDED FOR WVDOH ORDERS)	15.00	30.00
24	1	Sizes 7XL through 8XL without logo SPECIFY QTY OF EACH SIZE 7XL AND 8XL ON ORDER (THIS ITEM IS NOT INTENDED FOR WVDOH ORDERS)	15.00	15.00
SECTION TOTAL →				1,597.50
SECTION IV - Class 2 High-Visibility Low Cost "Adopt-A-Highway" Vests				
25	6	Size M through 2XL (adjustable) with "ADOPT-A-HWY" logo	4.45	26.70
26	1	Size 3XL through 4XL (adjustable) with "ADOPT-A-HWY" logo	4.45	4.45
27	6	Size M through 2XL (adjustable) without logo (THIS ITEM IS NOT INTENDED FOR WVDOH ORDERS)	3.00	18.00
28	1	Size 3XL through 4XL (adjustable) without logo (THIS ITEM IS NOT INTENDED FOR WVDOH ORDERS)	3.00	3.00
SECTION TOTAL →				52.15

WVDOH PERSONNEL

An online form is in place in order for District personnel to submit a documented report to the Traffic Engineering Division regarding issues associated with material orders. This form is intended to serve as a manner in which District personnel may quickly and easily submit a documented report to the Traffic Engineering Division regarding issues associated with ordering, delivery and receipt, quality, or order reconciliation issues associated with any of the materials ordered. This form may also be used to report issues with the installation or post-installation performance of materials. This form is located in the "Traffic" section of the WVDOH intranet site (Click on "Traffic" on the left side of the page, then click on "PO Contract Report" on the left side of the page). The direct address for the location of this form is <http://sharepoint.wv.gov/sites/do/highways/traffic/pocontractreport/Pages/default.aspx>. Once the report is submitted, an email verification will be automatically sent and an email notice will be sent to the Traffic Engineering Division. All reports submitted will be responded to by the Traffic Engineering Division. The Traffic Engineering Division will work with the individual at the District submitting the report to obtain additional needed facts or documentation such as photos or product samples, and will contact and work with the Contract Vendor and Materials Division if needed in order to reconcile the issues in a manner acceptable to all parties if possible. Typically, as a final step to address reported issues, the Traffic Engineering Division will complete and submit a WV-82 Vendor Performance Form in order to officially document any issues and their outcome. The initial point of contact for any submitted reports is Bruce Miller. If you have any questions or would like to follow up on the status of a report that has been submitted, please contact Mr. Miller at 558-9454 or bruce.f.miller@wv.gov.

GRAND TOTAL \$4,347.65

FFOODDWW

ADOPT - A - HWY

State of West Virginia

VENDOR PREFERENCE CERTIFICATE

Certification and application* is hereby made for Preference in accordance with West Virginia Code, §5A-3-37. (Does not apply to construction contracts). West Virginia Code, §5A-3-37, provides an opportunity for qualifying vendors to request (at the time of bid) preference for their residency status. Such preference is an evaluation method only and will be applied only to the cost bid in accordance with the West Virginia Code. This certificate for application is to be used to request such preference. The Purchasing Division will make the determination of the Resident Vendor Preference, if applicable.

- 1. Application is made for 2.5% resident vendor preference for the reason checked: Bidder is an individual resident vendor and has resided continuously in West Virginia for four (4) years immediately preceding the date of this certification; or, Bidder is a partnership, association or corporation resident vendor and has maintained its headquarters or principal place of business continuously in West Virginia for four (4) years immediately preceding the date of this certification; or 80% of the ownership interest of Bidder is held by another individual, partnership, association or corporation resident vendor who has maintained its headquarters or principal place of business continuously in West Virginia for four (4) years immediately preceding the date of this certification; or, Bidder is a nonresident vendor which has an affiliate or subsidiary which employs a minimum of one hundred state residents and which has maintained its headquarters or principal place of business within West Virginia continuously for the four (4) years immediately preceding the date of this certification; or,
2. Application is made for 2.5% resident vendor preference for the reason checked: Bidder is a resident vendor who certifies that, during the life of the contract, on average at least 75% of the employees working on the project being bid are residents of West Virginia who have resided in the state continuously for the two years immediately preceding submission of this bid; or,
3. Application is made for 2.5% resident vendor preference for the reason checked: Bidder is a nonresident vendor employing a minimum of one hundred state residents or is a nonresident vendor with an affiliate or subsidiary which maintains its headquarters or principal place of business within West Virginia employing a minimum of one hundred state residents who certifies that, during the life of the contract, on average at least 75% of the employees or Bidder's affiliate's or subsidiary's employees are residents of West Virginia who have resided in the state continuously for the two years immediately preceding submission of this bid; or,
4. Application is made for 5% resident vendor preference for the reason checked: Bidder meets either the requirement of both subdivisions (1) and (2) or subdivision (1) and (3) as stated above; or,
5. Application is made for 3.5% resident vendor preference who is a veteran for the reason checked: Bidder is an individual resident vendor who is a veteran of the United States armed forces, the reserves or the National Guard and has resided in West Virginia continuously for the four years immediately preceding the date on which the bid is submitted; or,
6. Application is made for 3.5% resident vendor preference who is a veteran for the reason checked: Bidder is a resident vendor who is a veteran of the United States armed forces, the reserves or the National Guard, if, for purposes of producing or distributing the commodities or completing the project which is the subject of the vendor's bid and continuously over the entire term of the project, on average at least seventy-five percent of the vendor's employees are residents of West Virginia who have resided in the state continuously for the two immediately preceding years.

Bidder understands if the Secretary of Revenue determines that a Bidder receiving preference has failed to continue to meet the requirements for such preference, the Secretary may order the Director of Purchasing to: (a) reject the bid; or (b) assess a penalty against such Bidder in an amount not to exceed 5% of the bid amount and that such penalty will be paid to the contracting agency or deducted from any unpaid balance on the contract or purchase order.

By submission of this certificate, Bidder agrees to disclose any reasonably requested information to the Purchasing Division and authorizes the Department of Revenue to disclose to the Director of Purchasing appropriate information verifying that Bidder has paid the required business taxes, provided that such information does not contain the amounts of taxes paid nor any other information deemed by the Tax Commissioner to be confidential.

Under penalty of law for false swearing (West Virginia Code, §61-5-3), Bidder hereby certifies that this certificate is true and accurate in all respects; and that if a contract is issued to Bidder and if anything contained within this certificate changes during the term of the contract, Bidder will notify the Purchasing Division in writing immediately.

Bidder: _____ Signed: _____

Date: _____ Title: _____

*Check any combination of preference consideration(s) indicated above, which you are entitled to receive.

RFQ No. 8512C2026

STATE OF WEST VIRGINIA
Purchasing Division

PURCHASING AFFIDAVIT

West Virginia Code §5A-3-10a states: No contract or renewal of any contract may be awarded by the state or any of its political subdivisions to any vendor or prospective vendor when the vendor or prospective vendor or a related party to the vendor or prospective vendor is a debtor and the debt owned is an amount greater than one thousand dollars in the aggregate

DEFINITIONS:

"Debt" means any assessment, premium, penalty, fine, tax or other amount of money owed to the state or any of its political subdivisions because of a judgment, fine, permit violation, license assessment, defaulted workers' compensation premium, penalty or other assessment presently delinquent or due and required to be paid to the state or any of its political subdivisions, including any interest or additional penalties accrued thereon.

"Debtor" means any individual, corporation, partnership, association, Limited Liability Company or any other form or business association owing a debt to the state or any of its political subdivisions. "Political subdivision" means any county commission; municipality; county board of education; any instrumentality established by a county or municipality; any separate corporation or instrumentality established by one or more counties or municipalities, as permitted by law; or any public body charged by law with the performance of a government function or whose jurisdiction is coextensive with one or more counties or municipalities. "Related party" means a party, whether an individual, corporation, partnership, association, limited liability company or any other form or business association or other entity whatsoever, related to any vendor by blood, marriage, ownership or contract through which the party has a relationship of ownership or other interest with the vendor so that the party will actually or by effect receive or control a portion of the benefit, profit or other consideration from performance of a vendor contract with the party receiving an amount that meets or exceeds five percent of the total contract amount.

EXCEPTION: The prohibition of this section does not apply where a vendor has contested any tax administered pursuant to chapter eleven of this code, workers' compensation premium, permit fee or environmental fee or assessment and the matter has not become final or where the vendor has entered into a payment plan or agreement and the vendor is not in default of any of the provisions of such plan or agreement.

Under penalty of law for false swearing (*West Virginia Code* §61-5-3), it is hereby certified that the vendor affirms and acknowledges the information in this affidavit and is in compliance with the requirements as stated.

WITNESS THE FOLLOWING SIGNATURE

Vendor's Name: Lohmann & Rauscher, Inc.

Authorized Signature: *Michael R. Hall* Michael R. Hall Date: 11/29/11

State of Kansas

County of Shawnee, to-wit:

Taken, subscribed, and sworn to before me this 29 day of November 2011

My Commission expires August 18, 20 15

AFFIX SEAL HERE

NOTARY PUBLIC _____

