



State of West Virginia
 Department of Administration
 Purchasing Division
 2019 Washington Street East
 Post Office Box 50130
 Charleston, WV 25305-0130

**Request for
 Quotation**

RFQ NUMBER
 7012EC10

PAGE
 1

ADDRESS CORRESPONDENCE TO ATTENTION OF
 ALAN CUMMINGS
 304-558-2402

VENDOR

RFQ COPY
 TYPE NAME/ADDRESS HERE
State Equipment, Inc.
 P.O. Box 3939
 Charleston, WV 25339

SHIP TO

DIVISION OF HIGHWAYS
 EQUIPMENT DIVISION
 ROUTE 33
 BRUSHY FORK ROAD
 BUCKHANNON, WV
 26201 304-472-1750

DATE PRINTED 05/02/2012	TERMS OF SALE NET 30	SHIP VIA OUR TRUCK	F.O.B. DESTINATION	FREIGHT TERMS PREPAID
BID OPENING DATE: 06/06/2012		BID OPENING TIME 01:30PM		

LINE	QUANTITY	UOP	CAT NO.	ITEM NUMBER	UNIT PRICE	AMOUNT
0001	1	EA		975-66	\$111,769.00	\$111,769.00
				(1) CASE CX145C		
				HYDRAULIC TRACK EXCAVATOR		
				OPEN-END CONTRACT		
				THE WEST VIRGINIA STATE PURCHASING DIVISION FOR THE AGENCY, THE WEST VIRGINIA DIVISION OF HIGHWAYS, IS SOLICITING BIDS TO PROVIDE THE AGENCY WITH GALVANIZED STEEL GRID DECK WITH ACCESSORIES PER THE ATTACHED SPECIFICATIONS.		
				MANDATORY PRE-BID		
				A MANDATORY PRE-BID WILL BE HELD ON 05/24/2012 AT 10:30 A.M. IN THE CONFERENCE ROOM OF THE PURCHASING DIVISION OFFICES LOCATED AT 2019 WASHINGTON STREET, EAST, CHARLESTON, WV 25305. ALL INTERESTED PARTIES ARE REQUIRED TO ATTEND THIS MEETING. FAILURE TO ATTEND THE MANDATORY PRE-BID SHALL RESULT IN DISQUALIFICATION OF THE BID. NO ONE PERSON MAY REPRESENT MORE THAN ONE BIDDER.		
				AN ATTENDANCE SHEET WILL BE MADE AVAILABLE FOR ALL POTENTIAL BIDDERS TO COMPLETE. THIS WILL SERVE AS THE OFFICIAL DOCUMENT VERIFYING ATTENDANCE AT THE MANDATOR PRE-BID. FAILURE TO PROVIDE YOUR COMPANY AND REPRESENTATIVE NAME ON THE ATTENDANCE SHEET WILL RESULT IN DISQUALIFICATION OF THE BID. THE STATE WILL NOT ACCEPT ANY OTHER DOCUMENTATION TO VERIFY ATTENDANCE. THE BIDDER IS RESPONSIBLE FOR ENSURING THEY HAVE COMPLETED THE INFORMATION REQUIRED ON THE ATTENDANCE		

RECEIVED
 2012 JUN 27 PM 1:20
 WV PURCHASING
 DIVISION

SEE REVERSE SIDE FOR TERMS AND CONDITIONS

SIGNATURE: TELEPHONE: 304-776-4405 DATE: 6-26-2012

TITLE: GENERAL MANAGER FEIN: 550658298 ADDRESS CHANGES TO BE NOTED ABOVE

WHEN RESPONDING TO RFQ, INSERT NAME AND ADDRESS IN SPACE ABOVE LABELED 'VENDOR'

**GENERAL TERMS & CONDITIONS
REQUEST FOR QUOTATION (RFQ) AND REQUEST FOR PROPOSAL (RFP)**

1. Awards will be made in the best interest of the State of West Virginia.
2. The State may accept or reject in part, or in whole, any bid.
3. Prior to any award, the apparent successful vendor must be properly registered with the Purchasing Division and have paid the required \$125 fee.
4. All services performed or goods delivered under State Purchase Order/Contracts are to be continued for the term of the Purchase Order/Contracts, contingent upon funds being appropriated by the Legislature or otherwise being made available. In the event funds are not appropriated or otherwise available for these services or goods this Purchase Order/Contract becomes void and of no effect after June 30.
5. Payment may only be made after the delivery and acceptance of goods or services.
6. Interest may be paid for late payment in accordance with the *West Virginia Code*.
7. Vendor preference will be granted upon written request in accordance with the *West Virginia Code*.
8. The State of West Virginia is exempt from federal and state taxes and will not pay or reimburse such taxes.
9. The Director of Purchasing may cancel any Purchase Order/Contract upon 30 days written notice to the seller.
10. The laws of the State of West Virginia and the *Legislative Rules* of the Purchasing Division shall govern the purchasing process.
11. Any reference to automatic renewal is hereby deleted. The Contract may be renewed only upon mutual written agreement of the parties.
12. **BANKRUPTCY:** In the event the vendor/contractor files for bankruptcy protection, the State may deem this contract null and void, and terminate such contract without further order.
13. **HIPAA BUSINESS ASSOCIATE ADDENDUM:** The West Virginia State Government HIPAA Business Associate Addendum (BAA), approved by the Attorney General, is available online at www.state.wv.us/admin/purchase/vrc/hipaa.html and is hereby made part of the agreement provided that the Agency meets the definition of a Cover Entity (45 CFR §160.103) and will be disclosing Protected Health Information (45 CFR §160.103) to the vendor.
14. **CONFIDENTIALITY:** The vendor agrees that he or she will not disclose to anyone, directly or indirectly, any such personally identifiable information or other confidential information gained from the agency, unless the individual who is the subject of the information consents to the disclosure in writing or the disclosure is made pursuant to the agency's policies, procedures, and rules. Vendor further agrees to comply with the Confidentiality Policies and Information Security Accountability Requirements, set forth in <http://www.state.wv.us/admin/purchase/privacy/noticeConfidentiality.pdf>.
15. **LICENSING:** Vendors must be licensed and in good standing in accordance with any and all state and local laws and requirements by any state or local agency of West Virginia, including, but not limited to, the West Virginia Secretary of State's Office, the West Virginia Tax Department, and the West Virginia Insurance Commission. The vendor must provide all necessary releases to obtain information to enable the director or spending unit to verify that the vendor is licensed and in good standing with the above entities.
16. **ANTITRUST:** In submitting a bid to any agency for the State of West Virginia, the bidder offers and agrees that if the bid is accepted the bidder will convey, sell, assign or transfer to the State of West Virginia all rights, title and interest in and to all causes of action it may now or hereafter acquire under the antitrust laws of the United States and the State of West Virginia for price fixing and/or unreasonable restraints of trade relating to the particular commodities or services purchased or acquired by the State of West Virginia. Such assignment shall be made and become effective at the time the purchasing agency tenders the initial payment to the bidder.

I certify that this bid is made without prior understanding, agreement, or connection with any corporation, firm, limited liability company, partnership, or person or entity submitting a bid for the same material, supplies, equipment or services and is in all respects fair and without collusion or fraud. I further certify that I am authorized to sign the certification on behalf of the bidder or this bid.

INSTRUCTIONS TO BIDDERS

1. Use the quotation forms provided by the Purchasing Division. Complete all sections of the quotation form.
2. Items offered must be in compliance with the specifications. Any deviation from the specifications must be clearly indicated by the bidder. Alternates offered by the bidder as EQUAL to the specifications must be clearly defined. A bidder offering an alternate should attach complete specifications and literature to the bid. The Purchasing Division may waive minor deviations to specifications.
3. Unit prices shall prevail in case of discrepancy. All quotations are considered F.O.B. destination unless alternate shipping terms are clearly identified in the quotation.
4. All quotations must be delivered by the bidder to the office listed below prior to the date and time of the bid opening. Failure of the bidder to deliver the quotations on time will result in bid disqualifications: Department of Administration, Purchasing Division, 2019 Washington Street East, P.O. Box 50130, Charleston, WV 25305-0130
5. Communication during the solicitation, bid, evaluation or award periods, except through the Purchasing Division, is strictly prohibited (W.Va. C.S.R. §148-1-6.6).



State of West Virginia
 Department of Administration
 Purchasing Division
 2019 Washington Street East
 Post Office Box 50130
 Charleston, WV 25305-0130

Request for Quotation

BFO NUMBER
 7012EC10

PAGE
 2

ADDRESS CORRESPONDENCE TO ATTENTION OF:
 ALAN CUMMINGS
 304-558-2402

RFQ COPY
 TYPE NAME/ADDRESS HERE

V
E
N
D
O
R

S
H
I
P
T
O

DIVISION OF HIGHWAYS
 EQUIPMENT DIVISION
 ROUTE 33
 BRUSHY FORK ROAD
 BUCKHANNON, WV
 26201 304-472-1750

DATE PRINTED	TERMS OF SALE	SHIP VIA	F.O.B.	FREIGHT TERMS
05/02/2012	NET 30	OUR TRUCK	DESTINATION	PREPAID

BID OPENING DATE: 06/06/2012 BID OPENING TIME 01:30PM

LINE	QUANTITY	UQP	CAT. NO.	ITEM NUMBER	UNIT PRICE	AMOUNT
<p>SHEET. THE PURCHASING DIVISION AND THE STATE AGENCY WILL NOT ASSUME ANY RESPONSIBILITY FOR A BIDDER'S FAILURE TO COMPLETE THE PRE-BID ATTENDANCE SHEET. IN ADDITION, WE REQUEST THAT ALL POTENTIAL BIDDERS INCLUDE THEIR PHONE AND FAX NUMBERS.</p> <p>ALL POTENTIAL BIDDERS ARE REQUESTED TO ARRIVE PRIOR TO THE STARTING TIME FOR THE PRE-BID. BIDDERS WHO ARRIVE LATE, BUT PRIOR TO THE DISMISSAL OF THE TECHNICAL PORTION OF THE PRE-BID WILL BE PERMITTED TO SIGN IN. BIDDERS WHO ARRIVE AFTER CONCLUSION OF THE TECHNICAL PORTION OF THE PRE-BID, BUT DURING ANY SUBSEQUENT PART OF THE PRE-BID WILL NOT BE PERMITTED TO SIGN THE ATTENDANCE SHEET.</p> <p>TECHNICAL QUESTIONS CONCERNING THIS SOLICITATION MUST BE SUBMITTED IN WRITING TO ALAN CUMMINGS IN THE WEST VIRGINIA STATE PURCHASING DIVISION VIA FAX AT 304-558-4115 OR VIA EMAIL AT ALAN.W.CUMMINGS@WV.GOV.</p> <p>DEADLINE FOR TECHNICAL QUESTIONS IS 05/30/12 AT THE CLOSE OF BUSINESS.</p> <p>EXHIBIT 3</p> <p>LIFE OF CONTRACT: THIS CONTRACT BECOMES EFFECTIVE ON AWARD AND EXTENDS FOR A PERIOD OF ONE (1) YEAR OR UNTIL SUCH "REASONABLE TIME" THEREAFTER AS IS NECESSARY TO OBTAIN A NEW CONTRACT OR RENEW THE ORIGINAL CONTRACT. THE "REASONABLE TIME" PERIOD SHALL NOT EXCEED TWELVE (12) MONTHS. DURING THIS "REASONABLE TIME" THE VENDOR MAY TERMINATE THIS CONTRACT FOR ANY REASON UPON GIVING THE DIRECTOR OF PURCHASING 30 DAYS WRITTEN NOTICE.</p> <p>UNLESS SPECIFIC PROVISIONS ARE STIPULATED ELSEWHERE</p>						

SEE REVERSE SIDE FOR TERMS AND CONDITIONS

SIGNATURE 	TELEPHONE 304-776-4405	DATE 6-26-2012
TITLE GENERAL MANAGER	FEIN 550658298	ADDRESS CHANGES TO BE NOTED ABOVE

WHEN RESPONDING TO RFQ, INSERT NAME AND ADDRESS IN SPACE ABOVE LABELED 'VENDOR'



State of West Virginia
 Department of Administration
 Purchasing Division
 2019 Washington Street East
 Post Office Box 50130
 Charleston, WV 25305-0130

Request for Quotation

RFQ NUMBER
 7012EC10

PAGE
 3

ADDRESS CORRESPONDENCE TO ATTENTION OF:
 ALAN CUMMINGS
 304-558-2402

VENDOR

RFQ COPY
 TYPE NAME/ADDRESS HERE

SHIP TO

DIVISION OF HIGHWAYS
 EQUIPMENT DIVISION
 ROUTE 33
 BRUSHY FORK ROAD
 BUCKHANNON, WV
 26201 304-472-1750

DATE PRINTED 05/02/2012	TERMS OF SALE NET 30	SHIP VIA OUR TRUCK	F.O.B. DESTINATION	FREIGHT TERMS PREPAID
----------------------------	-------------------------	-----------------------	-----------------------	--------------------------

BID OPENING DATE: 06/06/2012 BID OPENING TIME 01:30PM

LINE	QUANTITY	UOP	CAT NO	ITEM NUMBER	UNIT PRICE	AMOUNT
<p>IN THIS CONTRACT DOCUMENT BY THE STATE OF WEST VIRGINIA, ITS AGENCIES, OR POLITICAL SUBDIVISIONS, THE TERMS, CONDITIONS, AND PRICING SET FORTH HEREIN ARE FIRM FOR THE LIFE OF THE CONTRACT.</p> <p>RENEWAL: THIS CONTRACT MAY BE RENEWED UPON THE MUTUAL WRITTEN CONSENT OF THE SPENDING UNIT AND VENDOR, SUBMITTED TO THE DIRECTOR OF PURCHASING THIRTY (30) DAYS PRIOR TO THE EXPIRATION DATE. SUCH RENEWAL SHALL BE IN ACCORDANCE WITH THE TERMS AND CONDITIONS OF THE ORIGINAL CONTRACT AND SHALL BE LIMITED TO TWO (2) ONE (1) YEAR PERIODS.</p> <p>CANCELLATION: THE DIRECTOR OF PURCHASING RESERVES THE RIGHT TO CANCEL THIS CONTRACT IMMEDIATELY UPON WRITTEN NOTICE TO THE VENDOR IF THE COMMODITIES AND/OR SERVICES SUPPLIED ARE OF AN INFERIOR QUALITY OR DO NOT CONFORM TO THE SPECIFICATIONS OF THE BID AND CONTRACT HEREIN.</p> <p>OPEN MARKET CLAUSE: THE DIRECTOR OF PURCHASING MAY AUTHORIZE A SPENDING UNIT TO PURCHASE ON THE OPEN MARKET, WITHOUT THE FILING OF A REQUISITION OR COST ESTIMATE, ITEMS SPECIFIED ON THIS CONTRACT FOR IMMEDIATE DELIVERY IN EMERGENCIES DUE TO UNFORESEEN CAUSES (INCLUDING BUT NOT LIMITED TO DELAYS IN TRANSPORTATION OR AN UNANTICIPATED INCREASE IN THE VOLUME OF WORK.)</p> <p>QUANTITIES: QUANTITIES LISTED IN THE REQUISITION ARE APPROXIMATIONS ONLY, BASED ON ESTIMATES SUPPLIED BY THE STATE SPENDING UNIT. IT IS UNDERSTOOD AND AGREED THAT THE CONTRACT SHALL COVER THE QUANTITIES ACTUALLY ORDERED FOR DELIVERY DURING THE TERM OF THE CONTRACT, WHETHER MORE OR LESS THAN THE QUANTITIES SHOWN.</p> <p>ORDERING PROCEDURE: SPENDING UNIT(S) SHALL ISSUE A</p>						

SEE REVERSE SIDE FOR TERMS AND CONDITIONS

SIGNATURE 	TELEPHONE 304-776-4405	DATE 6-26-2012
TITLE GENERAL MANGER	FEIN 550658298	ADDRESS CHANGES TO BE NOTED ABOVE

WHEN RESPONDING TO RFQ, INSERT NAME AND ADDRESS IN SPACE ABOVE LABELED 'VENDOR'



State of West Virginia
 Department of Administration
 Purchasing Division
 2019 Washington Street East
 Post Office Box 50130
 Charleston, WV 25305-0130

Request for Quotation

RFQ NUMBER
 7012EC10

PAGE
 4

ADDRESS CORRESPONDENCE TO ATTENTION OF:
 ALAN CUMMINGS
 304-558-2402

RFQ COPY
 TYPE NAME/ADDRESS HERE

VENDOR

SHIP TO

DIVISION OF HIGHWAYS
 EQUIPMENT DIVISION
 ROUTE 33
 BRUSHY FORK ROAD
 BUCKHANNON, WV
 26201 304-472-1750

DATE PRINTED	TERMS OF SALE	SHIP VIA	F.O.B.	FREIGHT TERMS
05/02/2012	NET 30	OUR TRUCK	DESTINATION	PREPAID
BID OPENING DATE: 06/06/2012		BID OPENING TIME 01:30PM		

LINE	QUANTITY	UOP	CAT. NO.	ITEM NUMBER	UNIT PRICE	AMOUNT
<p>WRITTEN STATE CONTRACT ORDER (FORM NUMBER WV-39) TO THE VENDOR FOR COMMODITIES COVERED BY THIS CONTRACT. THE ORIGINAL COPY OF THE WV-39 SHALL BE MAILED TO THE VENDOR AS AUTHORIZATION FOR SHIPMENT, A SECOND COPY MAILED TO THE PURCHASING DIVISION, AND A THIRD COPY RETAINED BY THE SPENDING UNIT.</p> <p>BANKRUPTCY: IN THE EVENT THE VENDOR/CONTRACTOR FILES FOR BANKRUPTCY PROTECTION, THE STATE MAY DEEM THE CONTRACT NULL AND VOID, AND TERMINATE SUCH CONTRACT WITHOUT FURTHER ORDER.</p> <p>THE TERMS AND CONDITIONS CONTAINED IN THIS CONTRACT SHALL SUPERSEDE ANY AND ALL SUBSEQUENT TERMS AND CONDITIONS WHICH MAY APPEAR ON ANY ATTACHED PRINTED DOCUMENTS SUCH AS PRICE LISTS, ORDER FORMS, SALES AGREEMENTS OR MAINTENANCE AGREEMENTS, INCLUDING ANY ELECTRONIC MEDIUM SUCH AS CD-ROM.</p> <p>REV. 01/17/2012 EXHIBIT 4</p> <p>LOCAL GOVERNMENT BODIES: UNLESS THE VENDOR INDICATES IN THE BID HIS REFUSAL TO EXTEND THE PRICES, TERMS, AND CONDITIONS OF THE BID TO COUNTY, SCHOOL, MUNICIPAL AND OTHER LOCAL GOVERNMENT BODIES, THE BID SHALL EXTEND TO POLITICAL SUBDIVISIONS OF THE STATE OF WEST VIRGINIA. IF THE VENDOR DOES NOT WISH TO EXTEND THE PRICES, TERMS, AND CONDITIONS OF THE BID TO ALL POLITICAL SUBDIVISIONS OF THE STATE, THE VENDOR MUST CLEARLY INDICATE SUCH REFUSAL IN HIS BID. SUCH REFUSAL SHALL NOT PREJUDICE THE AWARD OF THIS CONTRACT IN ANY MANNER.</p> <p>REV. 3/88 EXHIBIT 10</p>						

SEE REVERSE SIDE FOR TERMS AND CONDITIONS

SIGNATURE	TELEPHONE 304-776-4405	DATE 6-26-2012
TITLE GENERAL MANAGER	FEIN 550658298	ADDRESS CHANGES TO BE NOTED ABOVE

WHEN RESPONDING TO RFQ, INSERT NAME AND ADDRESS IN SPACE ABOVE LABELED 'VENDOR'



State of West Virginia
 Department of Administration
 Purchasing Division
 2019 Washington Street East
 Post Office Box 50130
 Charleston, WV 25305-0130

Request for Quotation

RFQ NUMBER
 7012EC10

PAGE
 5

ADDRESS CORRESPONDENCE TO ATTENTION OF:
 ALAN CUMMINGS
 304-558-2402

VENDOR

RFQ COPY
 TYPE NAME/ADDRESS HERE

SHIP TO

DIVISION OF HIGHWAYS
 EQUIPMENT DIVISION
 ROUTE 33
 BRUSHY FORK ROAD
 BUCKHANNON, WV
 26201 304-472-1750

DATE PRINTED 05/02/2012	TERMS OF SALE NET 30	SHIP VIA OUR TRUCK	FOB DESTINATION	FREIGHT TERMS PREPAID
BID OPENING DATE: 06/06/2012		BID OPENING TIME 01:30PM		

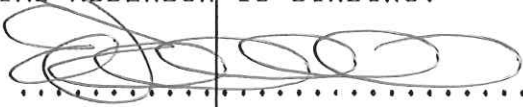
LINE	QUANTITY	UOP	CAT. NO.	ITEM NUMBER	UNIT PRICE	AMOUNT
REQUISITION NO.: 7012EC10....						
ADDENDUM ACKNOWLEDGEMENT						
I HEREBY ACKNOWLEDGE RECEIPT OF THE FOLLOWING CHECKED ADDENDUM(S) AND HAVE MADE THE NECESSARY REVISIONS TO MY PROPOSAL, PLANS AND/OR SPECIFICATION, ETC.						
ADDENDUM NO.'S:						
NO. 1 <i>[Signature]</i>						
NO. 2 <i>[Signature]</i>						
NO. 3 <i>[Signature]</i>						
NO. 4						
NO. 5						
I UNDERSTAND THAT FAILURE TO CONFIRM THE RECEIPT OF THE ADDENDUM(S) MAY BE CAUSE FOR REJECTION OF BIDS.						
VENDOR MUST CLEARLY UNDERSTAND THAT ANY VERBAL REPRESENTATION MADE OR ASSUMED TO BE MADE DURING ANY ORAL DISCUSSION HELD BETWEEN VENDOR'S REPRESENTATIVES AND ANY STATE PERSONNEL IS NOT BINDING. ONLY THE INFORMATION ISSUED IN WRITING AND ADDED TO THE SPECIFICATIONS BY AN OFFICIAL ADDENDUM IS BINDING.						
 SIGNATURE EDDIE ROWAN, JR.						

SEE REVERSE SIDE FOR TERMS AND CONDITIONS			
SIGNATURE <i>[Signature]</i>	TELEPHONE 304-776-4405	DATE 6-26-2012	
TITLE GENERAL MANAGER	FEIN 550658298	ADDRESS CHANGES TO BE NOTED ABOVE	

WHEN RESPONDING TO RFQ, INSERT NAME AND ADDRESS IN SPACE ABOVE LABELED 'VENDOR'



State of West Virginia
 Department of Administration
 Purchasing Division
 2019 Washington Street East
 Post Office Box 50130
 Charleston, WV 25305-0130

Request for Quotation

RFQ NUMBER
 7012EC10

PAGE
 6

ADDRESS CORRESPONDENCE TO ATTENTION OF:
 ALAN CUMMINGS
 304-558-2402

RFQ COPY

TYPE NAME/ADDRESS HERE

SHIP TO

DIVISION OF HIGHWAYS
 EQUIPMENT DIVISION
 ROUTE 33
 BRUSHY FORK ROAD
 BUCKHANNON, WV
 26201 304-472-1750

DATE PRINTED	TERMS OF SALE	SHIP VIA	F.O.B.	FREIGHT TERMS
05/02/2012	NET 30	OUR TRUCK	DESTINATION	PREPAID

BID OPENING DATE: 06/06/2012 BID OPENING TIME 01:30PM

LINE	QUANTITY	UOP	CAT. NO.	ITEM NUMBER	UNIT PRICE	AMOUNT
COMPANY STATE EQUIPMENT, INC. DATE						
NOTE: THIS ADDENDUM ACKNOWLEDGEMENT SHOULD BE SUBMITTED WITH THE BID. REV. 09/21/2009 NOTICE A SIGNED BID MUST BE SUBMITTED TO: DEPARTMENT OF ADMINISTRATION PURCHASING DIVISION BUILDING 15 2019 WASHINGTON STREET, EAST CHARLESTON, WV 25305-0130 THE BID SHOULD CONTAIN THIS INFORMATION ON THE FACE OF THE ENVELOPE OR THE BID MAY NOT BE CONSIDERED: SEALED BID BUYER: ALAN CUMMINGS - FILE 33 RFQ. NO.: 7012EC10 BID OPENING DATE: 06/06/2012 BID OPENING TIME: 1:30 P.M.						

SEE REVERSE SIDE FOR TERMS AND CONDITIONS

SIGNATURE	TELEPHONE 304-776-4405	DATE 6-26-2012
TITLE GENERAL MANAGER	FEIN 550658298	ADDRESS CHANGES TO BE NOTED ABOVE

WHEN RESPONDING TO RFQ, INSERT NAME AND ADDRESS IN SPACE ABOVE LABELED 'VENDOR'



State of West Virginia
 Department of Administration
 Purchasing Division
 2019 Washington Street East
 Post Office Box 50130
 Charleston, WV 25305-0130

Request for Quotation

RFQ NUMBER
 7012EC10

PAGE
 7

ADDRESS CORRESPONDENCE TO ATTENTION OF:
 ALAN CUMMINGS
 304-558-2402

RFQ COPY
 TYPE NAME/ADDRESS HERE

VENDOR

SHIP TO

DIVISION OF HIGHWAYS
 EQUIPMENT DIVISION
 ROUTE 33
 BRUSHY FORK ROAD
 BUCKHANNON, WV
 26201 304-472-1750

DATE PRINTED	TERMS OF SALE	SHIP VIA	F.O.B.	FREIGHT TERMS
05/02/2012	NET 30	OUR TRUCK	DESTINATION	PREPAID

BID OPENING DATE: 06/06/2012 BID OPENING TIME 01:30PM

LINE	QUANTITY	UOP	CAT NO	ITEM NUMBER	UNIT PRICE	AMOUNT
<p>PLEASE PROVIDE A FAX NUMBER IN CASE IT IS NECESSARY TO CONTACT YOU REGARDING YOUR BID: ----- 304-776-4409 -----</p> <p>CONTACT PERSON (PLEASE PRINT CLEARLY): ----- EDWARD M. ROWAN, JR. -----</p> <p>ANY INDIVIDUAL SIGNING THIS BID IS CERTIFYING THAT: (1) HE OR SHE IS AUTHORIZED BY THE BIDDER TO EXECUTE THE BID OR ANY DOCUMENTS RELATED THERETO ON BEHALF OF THE BIDDER, (2) THAT HE OR SHE IS AUTHORIZED TO BIND THE BIDDER IN A CONTRACTUAL RELATIONSHIP, AND (3) THAT THE BIDDER HAS PROPERLY REGISTERED WITH ANY STATE AGENCIES THAT MAY REQUIRE REGISTRATION.</p>						
***** THIS IS THE END OF RFQ 7012EC10 ***** TOTAL:						\$111,769.00

SEE REVERSE SIDE FOR TERMS AND CONDITIONS

SIGNATURE		TELEPHONE	DATE
TITLE GENERAL MANGER		304-776-4405	6-26-2012
FEIN 550658298		ADDRESS CHANGES TO BE NOTED ABOVE	

WHEN RESPONDING TO RFQ, INSERT NAME AND ADDRESS IN SPACE ABOVE LABELED 'VENDOR'



State of West Virginia
 Department of Administration
 Purchasing Division
 2019 Washington Street East
 Post Office Box 50130
 Charleston, WV 25305-0130

**Request for
 Quotation**

REQ NUMBER
7012EC10

PAGE
1

ADDRESS CORRESPONDENCE TO ATTENTION OF
ALAN CUMMINGS 304-558-2402

VENDOR	*709054014	304-776-4406
	STATE EQUIPMENT INC	
	PO BOX 3939	
	CHARLESTON WV 25339	

SHIP TO	DIVISION OF HIGHWAYS	
	EQUIPMENT DIVISION	
	ROUTE 33	
	BRUSHY FORK ROAD	
	26201	304-472-1750

DATE PRINTED	TERMS OF SALE	SHIP VIA	F.O.B.	FREIGHT TERMS
06/01/2012	NET 30	OUR TRUCK	DESTINATION	PREPAID

BID OPENING DATE: 06/13/2012 BID OPENING TIME: 01:30PM

LINE	QUANTITY	UOP	CAT NO	ITEM NUMBER	UNIT PRICE	AMOUNT
ADDENDUM NO . 01						
ISSUED TO EXTEND BID OPENING DATE FROM 06/06/12 AT 1:30 P.M. TO 06/13/12 AT 1:30 P.M AND TO DISTRIBUTE PRE-BID SIGN-IN SHEET FROM THE MANDATORY PREBID MEETING.						
0001	1	EA		975-66	\$111,769.00	\$111,769.00
				HYDRAULIC TRACK EXCAVATOR		
				(1) CASE CX145C		
***** THIS IS THE END OF RFQ 7012EC10 ***** TOTAL:						\$111,769.00

SEE REVERSE SIDE FOR TERMS AND CONDITIONS

SIGNATURE	TELEPHONE	DATE
	304-776-4405	6-26-2012
TITLE	FEIN	ADDRESS CHANGES TO BE NOTED ABOVE
GENERAL MANAGER	550658298	

WHEN RESPONDING TO RFQ, INSERT NAME AND ADDRESS IN SPACE ABOVE LABELED 'VENDOR'

PRE-BID CONFERENCE
SIGN IN SHEET

Request for Quotation Number:

7012EC10

Date:

5/24/2012 10:30

Project Description:

Hydraulic Track Excavators

PLEASE PRINT LEGIBLY. THIS INFORMATION IS ESSENTIAL TO CONTACT THE ATTENDEES IN A TIMELY MANNER. FAILURE TO DO SO MAY RESULT IN DELAYS IN YOUR COMPANY GETTING IMPORTANT BID INFORMATION.

Firm Name:	<u>Phon Hall</u>
Firm Address:	<u>DOH</u>
Representative Attending:	
Phone Number:	
Fax Number:	
Email Address:	

Firm Name:	<u>Leslie Equipment Company</u>
Firm Address:	<u>P.O. Box 1647</u> <u>Elkins, WV 26241</u>
Representative Attending:	<u>David Coaseand</u>
Phone Number:	<u>304-642-9826</u>
Fax Number:	<u>304-636-3516</u>
Email Address:	<u>Coaseanddavid @ LEC1.com</u>

Firm Name:	<u>WEST VIRGINIA TRACKER</u>
Firm Address:	<u>P.O. Box 433</u> <u>CHARLESTON WV 25322</u>
Representative Attending:	<u>GARY GRADY</u>
Phone Number:	<u>304-346-5301</u>
Fax Number:	<u>304-346-5305</u>
Email Address:	<u>WVTRACKER@WV.COM</u>

Firm Name:	<u>C.I. Walker Machinery Co.</u>
Firm Address:	<u>P.O. Box 2427</u> <u>Charleston, WV 25329</u>
Representative Attending:	<u>Matt Conner</u>
Phone Number:	<u>(304) 543-5406</u>
Fax Number:	<u>(304) 759-6406</u>
Email Address:	<u>mconner @ walker-cat.com</u>

Firm Name:	<u>RISH EQUIPMENT CO.</u>
Firm Address:	<u>650 WINFIELD RD</u> <u>ROUTE 817</u> <u>ST. ALBANS, WV 25177</u>
Representative Attending:	<u>TRAS GANOTE</u>
Phone Number:	<u>304-755-3311</u>
Fax Number:	<u>304-755-3603</u>
Email Address:	<u>Tganote @ RISH.COM</u>

Firm Name:	<u>MH Equipment Co.</u>
Firm Address:	<u>126 Lakeside Dr.</u> <u>Charleston, WV</u> <u>25313</u>
Representative Attending:	<u>Erie W Shock</u>
Phone Number:	<u>304-741-3569</u>
Fax Number:	
Email Address:	<u>eshock @ mhjcb.com</u>

PRE-BID CONFERENCE
SIGN IN SHEET

Request for Quotation Number:

7012EC10

Date:

5/24/2012 10:30

Project Description:

Hydraulic Track Excavators

PLEASE PRINT LEGIBLY. THIS INFORMATION IS ESSENTIAL TO CONTACT THE ATTENDEES IN A TIMELY MANNER. FAILURE TO DO SO MAY RESULT IN DELAYS IN YOUR COMPANY GETTING IMPORTANT BID INFORMATION.

Firm Name:	STATE Equipment, Inc.
Firm Address:	P.O. Box 3939 CHARLESTON WV 25339
Representative Attending:	Eddie Raman, Jr
Phone Number:	304-776-4405
Fax Number:	304-776-4409
Email Address:	eddie@stateequipment.com

Firm Name:	WVDOH
Firm Address:	
Representative Attending:	Michael J. Neely
Phone Number:	
Fax Number:	
Email Address:	

Firm Name:	STATE Equipment INC
Firm Address:	PO Box 3939 Charleston, WV 25339
Representative Attending:	Rex Vanater
Phone Number:	304-776-4405
Fax Number:	304-776-4409
Email Address:	warranty@stateequipment.com

Firm Name:	WVDOH
Firm Address:	
Representative Attending:	Marcia Lee
Phone Number:	
Fax Number:	
Email Address:	

Firm Name:	STATE EQUIPMENT INC
Firm Address:	PO Box 3939 Charleston, WV 25339
Representative Attending:	TIM FALLECKER
Phone Number:	304-776-4405
Fax Number:	304-776-4409
Email Address:	tim.f@stateequipment.com

Firm Name:	
Firm Address:	
Representative Attending:	
Phone Number:	
Fax Number:	
Email Address:	



State of West Virginia
 Department of Administration
 Purchasing Division
 2019 Washington Street East
 Post Office Box 50130
 Charleston, WV 25305-0130

Request for Quotation

RFQ NUMBER
 7012EC10

PAGE
 1

ADDRESS CORRESPONDENCE TO ATTENTION OF:
 ALAN CUMMINGS
 304-558-2402

VENDOR

RFQ COPY
 TYPE NAME/ADDRESS HERE

SHIP TO

DIVISION OF HIGHWAYS
 EQUIPMENT DIVISION
 ROUTE 33
 BRUSHY FORK ROAD
 BUCKHANNON, WV
 26201 304-472-1750

DATE PRINTED	TERMS OF SALE	SHIP VIA	F.O.B.	FREIGHT TERMS
06/06/2012	NET 30	OUR TRUCK	DESTINATION	PREPAID

BID OPENING DATE: 06/13/2012 BID OPENING TIME 01:30PM

LINE	QUANTITY	UOP	CAT. NO.	ITEM NUMBER	UNIT PRICE	AMOUNT
0001	1	EA		975-66	\$111,769.00	\$111,769.00
ADDENDUM NO. 02 ISSUED TO DISTRIBUTE ADDITIONAL TERMS & CONDITIONS AND TO QUESTION AND ANSWER RESPONSE PAGE PER THE ATTACHED.						
HYDRAULIC TRACK EXCAVATOR (1) CASE CX145C						
***** THIS IS THE END OF RFQ 7012EC10 ***** TOTAL:						\$111,769.00

SEE REVERSE SIDE FOR TERMS AND CONDITIONS

SIGNATURE	TELEPHONE 304-776-4405	DATE 6-26-2012
TITLE GENERAL MANGER	FEIN 550658298	ADDRESS CHANGES TO BE NOTED ABOVE

WHEN RESPONDING TO RFQ, INSERT NAME AND ADDRESS IN SPACE ABOVE LABELED 'VENDOR'

**GENERAL TERMS & CONDITIONS
REQUEST FOR QUOTATION (RFQ) AND REQUEST FOR PROPOSAL (RFP)**

1. Awards will be made in the best interest of the State of West Virginia.
2. The State may accept or reject in part, or in whole, any bid.
3. Prior to any award, the apparent successful vendor must be properly registered with the Purchasing Division and have paid the required \$125 fee.
4. All services performed or goods delivered under State Purchase Order/Contracts are to be continued for the term of the Purchase Order/Contracts, contingent upon funds being appropriated by the Legislature or otherwise being made available. In the event funds are not appropriated or otherwise available for these services or goods this Purchase Order/Contract becomes void and of no effect after June 30.
5. Payment may only be made after the delivery and acceptance of goods or services.
6. Interest may be paid for late payment in accordance with the *West Virginia Code*.
7. Vendor preference will be granted upon written request in accordance with the *West Virginia Code*.
8. The State of West Virginia is exempt from federal and state taxes and will not pay or reimburse such taxes.
9. The Director of Purchasing may cancel any Purchase Order/Contract upon 30 days written notice to the seller.
10. The laws of the State of West Virginia and the *Legislative Rules* of the Purchasing Division shall govern the purchasing process.
11. Any reference to automatic renewal is hereby deleted. The Contract may be renewed only upon mutual written agreement of the parties.
12. **BANKRUPTCY:** In the event the vendor/contractor files for bankruptcy protection, the State may deem this contract null and void, and terminate such contract without further order.
13. **HIPAA BUSINESS ASSOCIATE ADDENDUM:** The West Virginia State Government HIPAA Business Associate Addendum (BAA), approved by the Attorney General, is available online at www.state.wv.us/admin/purchase/vrc/hipaa.html and is hereby made part of the agreement provided that the Agency meets the definition of a Cover Entity (45 CFR §160.103) and will be disclosing Protected Health Information (45 CFR §160.103) to the vendor.
14. **CONFIDENTIALITY:** The vendor agrees that he or she will not disclose to anyone, directly or indirectly, any such personally identifiable information or other confidential information gained from the agency, unless the individual who is the subject of the information consents to the disclosure in writing or the disclosure is made pursuant to the agency's policies, procedures, and rules. Vendor further agrees to comply with the Confidentiality Policies and Information Security Accountability Requirements, set forth in <http://www.state.wv.us/admin/purchase/privacy/noticeConfidentiality.pdf>.
15. **LICENSING:** Vendors must be licensed and in good standing in accordance with any and all state and local laws and requirements by any state or local agency of West Virginia, including, but not limited to, the West Virginia Secretary of State's Office, the West Virginia Tax Department, and the West Virginia Insurance Commission. The vendor must provide all necessary releases to obtain information to enable the director or spending unit to verify that the vendor is licensed and in good standing with the above entities.
16. **ANTITRUST:** In submitting a bid to any agency for the State of West Virginia, the bidder offers and agrees that if the bid is accepted the bidder will convey, sell, assign or transfer to the State of West Virginia all rights, title and interest in and to all causes of action it may now or hereafter acquire under the antitrust laws of the United States and the State of West Virginia for price fixing and/or unreasonable restraints of trade relating to the particular commodities or services purchased or acquired by the State of West Virginia. Such assignment shall be made and become effective at the time the purchasing agency tenders the initial payment to the bidder.

I certify that this bid is made without prior understanding, agreement, or connection with any corporation, firm, limited liability company, partnership, or person or entity submitting a bid for the same material, supplies, equipment or services and is in all respects fair and without collusion or fraud. I further certify that I am authorized to sign the certification on behalf of the bidder or this bid.

INSTRUCTIONS TO BIDDERS

1. Use the quotation forms provided by the Purchasing Division. Complete all sections of the quotation form.
2. Items offered must be in compliance with the specifications. Any deviation from the specifications must be clearly indicated by the bidder. Alternates offered by the bidder as EQUAL to the specifications must be clearly defined. A bidder offering an alternate should attach complete specifications and literature to the bid. The Purchasing Division may waive minor deviations to specifications.
3. Unit prices shall prevail in case of discrepancy. All quotations are considered F.O.B. destination unless alternate shipping terms are clearly identified in the quotation.
4. All quotations must be delivered by the bidder to the office listed below prior to the date and time of the bid opening. Failure of the bidder to deliver the quotations on time will result in bid disqualifications: Department of Administration, Purchasing Division, 2019 Washington Street East, P.O. Box 50130, Charleston, WV 25305-0130
5. Communication during the solicitation, bid, evaluation or award periods, except through the Purchasing Division, is strictly prohibited (W.Va. C.S.R. §148-1-6.6).

7012EC10
ADDENDUM NO. 2

ADDITIONAL TERMS AND CONDITIONS

Various Legislative acts passed in the 2012 session require inclusion of certain provisions in all state contracts. Accordingly, this addendum will add the three provisions listed below to the solicitation and resulting contract entered into between the State of West Virginia and the vendor. In the event that the solicitation is not for construction or architectural/engineering work, sections 2 and 3 below will not apply.

1. **BACKGROUND CHECK:** In accordance with W. Va. Code § 15-2D-3, the Director of the Division of Protective Services may require any service provider whose employees are regularly employed on the grounds or in the buildings of the Capitol complex or who have access to sensitive or critical information to submit to a fingerprint-based state and federal background inquiry through the state repository.

After the contract for such services has been approved, but before any such employees are permitted to be on the grounds or in the buildings of the Capitol complex or have access to sensitive or critical information, the service provider shall submit a list of all persons who will be physically present and working at the Capitol complex to the Director of the Division of Protective Services for purposes of verifying compliance with this provision.

The State reserves the right to prohibit a service provider's employees from accessing sensitive or critical information or to be present at the Capitol complex based upon results addressed from a criminal background check.

2. **SUBCONTRACTOR LIST SUBMISSION:** In accordance with W. Va. Code § 5-22-1, The apparent low bidder on a contract for the construction, alteration, decoration, painting or improvement of a new or existing building or structure valued at more than \$500,000.00 shall submit a list of all subcontractors who will perform more than \$25,000.00 of work on the project including labor and materials. This provision shall not apply to any other construction projects, such as highway, mine reclamation, water or sewer projects.

- a. **Required Information.** The subcontractor list shall contain the following information:

- I. Bidder's name
- II. Name of each subcontractor
- III. License numbers as required by W. Va. Code § 21-11-1 et. seq.

- iv. Notation that no subcontractors will be used if the bidder will perform the work

 - b. **Submission.** The completed subcontractor list shall be provided to the Purchasing Division within one business day of the opening of bids for review. Failure to submit the subcontractor list within one business day after the deadline for submitting bids shall result in disqualification of the bid.

 - c. **Substitution of Subcontractor.** Written approval must be obtained from the Purchasing Division before any subcontractor substitution is permitted. Substitutions are not permitted unless:
 - I. The subcontractor listed in the original bid has filed for bankruptcy;
 - II. The subcontractor in the original bid has been debarred or suspended; or
 - III. The contractor certifies in writing that the subcontractor listed in the original bill fails, is unable, or refuses to perform his subcontract.
3. **GREEN BUILDINGS MINIMUM ENERGY STANDARDS:** In accordance with § 22-29-4, all new building construction projects of public agencies that have not entered the schematic design phase prior to July 1, 2012, or any building construction project receiving state grant funds and appropriations, including public schools, that have not entered the schematic design phase prior to July 1, 2012, shall be designed and constructed complying with the ICC International Energy Conservation Code, adopted by the State Fire Commission, and the ANSI/ASHRAE/IESNA Standard 90.1-2007: *Provided*, That if any construction project has a commitment of federal funds to pay for a portion of such project, this provision shall only apply to the extent such standards are consistent with the federal standards.

PREBID ADDENDUM
7012EC10

HYDRAULIC TRACK EXCAVATOR

CHANGES TO SPECIFICATIONS:

FROM:

2. Pricing Pages: 3rd Paragraph – 1st Sentence
Notwithstanding the foregoing, the Purchasing Division may correct errors as its discretion.

TO:

2. Pricing Pages: 3rd Paragraph – 1st Sentence
Notwithstanding the foregoing, the Purchasing Division may correct errors at its discretion.

FROM:

VI. DELIVERY AND RETURN

1. Delivery Time: Vendor shall deliver standard orders within 90 working days after orders are received.

TO:

VI. DELIVERY AND RETURN

1. Delivery Time: Vendor shall deliver standard orders within 180 working days after orders are received.

DELETE:

VI. DELIVERY AND RETURN

1. Delivery Time: 2nd and 3rd Sentences
Vendor shall deliver emergency orders within one (1) working day after orders are received.
Vendor shall ship all orders in accordance with the above schedule and shall not hold orders until a minimum delivery quantity is met.

FROM:

VI. DELIVERY AND RETURN

1. Delivery Time: 4th Sentence
A completed pilot model for inspection must be provided within 60 calendar days after receipt of the purchase agreement by the successful vendor.

TO:

VI. DELIVERY AND RETURN

1. Delivery Time: 4th Sentence
A completed pilot model for inspection must be provided within 120 calendar days after receipt of the purchase agreement by the successful vendor.

ADDENDUM NO. 2
 PREBID ADDENDUM
 7012EC10

DELETE:

VI. DELIVERY AND RETURN

3.0 Delivery Payment/Risk of Loss: 3rd Sentence

The Agency will pay delivery charges on all emergency orders provided that Vendor invoices those delivery costs as a separate charge with the original freight bill attached to the invoice.

DELETE:

VII. MISCELLANEOUS

- 2. Vendor Supply:** Vendor must carry sufficient inventory of the Desired Items being offered to fulfill its obligations under this Contract. By signing its bid, Vendor certifies that it can supply the Desired Items contained in its bid response.

CHANGE NUMBERING SYSTEM ON THE FOLLOWING TO READ:

3. Reports to 2. Reports
4. Contract Manager to 3. Contract Manager
5. Mandatory Requirements to 4. Mandatory Requirements

ADD:

VII. MISCELLANEOUS

5. EXCEPTIONS TO NON-MANDATORY SPECIFICATIONS

Exception to a non-mandatory unit specification may be made by the bidder, providing the exception is not available from the manufacturer. **Any such exception must be noted on the bidder's evaluation report and should be accompanied by supporting documentation/literature from the manufacturer. Any exception must be indicated on a separate attachment to the bidder's evaluation report and labeled as "Exception to Specifications".** The state reserves the right to waive minor irregularities in bids or specifications in accordance with §148-1-4(f) of the WV Legislative Rules and Regulations.

ADDENDUM NO. 2

PREBID ADDENDUM
7012EC10

EXHIBIT A

VIII. SPECIFICATIONS:

DELETE:

2. Vendor shall deliver standard orders within 90 working days after orders are received.
3. A completed pilot model for inspection must be provided within 60 calendar days after receipt of the purchase agreement by the successful vendor.
4. Vendor shall deliver emergency orders within one (1) working day after orders are received.
5. Standard order delivery shall be F.O.B. destination to the Agency's location: West Virginia Division of Highways, Equipment Division, Route 33 and Brushy Fork Rd, Buckhannon, West Virginia

CHANGE TO READ:

11. Unspecified Accessories & Features - 1st Paragraph 4th Line
Change "qualify" to "quality"

ADDENDUM NO. 2
PREBID ADDENDUM
7012EC10

FROM:

12. Operating weight shall be minimum 28,000 pounds and maximum of 33,000 pounds including fuel, thumb, and bucket attached.

TO:

12. Operating weight shall be minimum 28,000 pounds and maximum of 35,000 pounds including fuel, thumb, and bucket attached.

QUESTIONS FROM VENDOR:

14. Do you need the capability to switch between one-way and two-way flow?
RESPONSE: No

Do you want the thumb controlled by an actuator within the joystick or by a foot pedal?
RESPONSE: Joystick

Is there a specific (or minimum/maximum) number of tines needed for the thumb?
RESPONSE: No

COST SHEET

Item Number	Estimated Quantity*	Unit of measure	Description	Unit Price	Extended Amount
1	10	Each	Hydraulic Track Excavator YEAR/MAKE/MODEL: 2012 CASE CX145C	\$111,769.00	\$1,117,690.00
			Total Amount		\$1,117,690.00

I hereby Certify that the item being bid meets or exceeds specifications as written and I will comply with them all:

STATE EQUIPMENT, INC.

P.O. BOX 3939

CHARLESTON, WV 25339

Vendor name and address and representative bidding

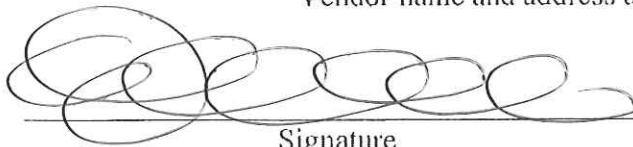

Signature

6-26-2012

Date

ADDENDUM NO. 2

WARRANTY AND SERVICE POLICY QUESTIONNAIRE

CHANGE HEADING TO READ:
FROM:

THIS FORM MUST BE COMPLETED IN ITS ENTIRETY AND SUBMITTED WITH YOUR BID.

TO:

THIS FORM MUST BE COMPLETED IN ITS ENTIRETY. PRIOR TO AWARD.



State of West Virginia
 Department of Administration
 Purchasing Division
 2019 Washington Street East
 Post Office Box 50130
 Charleston, WV 25305-0130

Solicitation

NUMBER
7012EC10

PAGE
1

ADDRESS CORRESPONDENCE TO ATTENTION OF:
ALAN CUMMINGS 304-558-2402

V E N D O R

*709054014 304-776-4406
 STATE EQUIPMENT INC
 PO BOX 3939

 CHARLESTON WV 25339

S H I P T O

DIVISION OF HIGHWAYS
 EQUIPMENT DIVISION
 ROUTE 33
 BRUSHY FORK ROAD
 BUCKHANNON, WV
 26201 304-472-1750

DATE PRINTED
06/10/2012

BID OPENING DATE: 06/27/2012 BID OPENING TIME 01:30PM

LINE	QUANTITY	UOP	CAT. NO.	ITEM NUMBER	UNIT PRICE	AMOUNT
ADDENDUM NO. 03 ISSUED TO DISTRIBUTE INFORMATION IN THE ATTACHED DOCUMENTATION.						
0001	1	EA		975-66	\$111,769.00	\$111,769.00
				HYDRAULIC TRACK EXCAVATOR		
				(1) CASE CX145C		
***** THIS IS THE END OF RFQ 7012EC10 ***** TOTAL:						\$111,769.00

SIGNATURE 	TELEPHONE 304-776-4405	DATE 6-26-2012
TITLE GENERAL MANAGER	FEIN 550658298	ADDRESS CHANGES TO BE NOTED ABOVE

WHEN RESPONDING TO SOLICITATION, INSERT NAME AND ADDRESS IN SPACE ABOVE LABELED 'VENDOR'

SOLICITATION NUMBER: 7012EC10
Addendum Number: 3

The purpose of this addendum is to modify the solicitation identified as 7012EC10 ("Solicitation") to reflect the change(s) identified and described below.

Applicable Addendum Category:

- Modify bid opening date and time
- Modify specifications of product or service being sought
- Attachment of vendor questions and responses
- Attachment of pre-bid sign-in sheet
- Correction of error
- Other

Description of Modification to Solicitation:

Issued to clarify specifications and change bid opening date from 06/13/12 at 1:30 P.M. to 06/27/12 at 1:30 P.M.

To change paragraph 1, on page #1 of the RFQ from "The West Virginia Purchasing Division for the Agency, the West Virginia Division of Highways, is soliciting bids to provide the agency with galvanized steel grid deck with accessories per the attached specifications" to "The West Virginia Purchasing Division for the Agency, the West Virginia Division of Highways, is soliciting bids to provide the agency with hydraulic track excavators per the attached specifications"

Further, to clarify the following found on page 8, Warranty and service policy questionnaire, of addendum no.2, from "THIS FORM MUST BE COMPLETED IN ITS ENTIRETY. PRIOR TO AWARD." to "THIS FORM MUST BE COMPLETED IN ITS ENTIRETY PRIOR TO AWARD."

Additional Documentation: Documentation related to this Addendum (if any) has been included herewith as Attachment A and is specifically incorporated herein by reference.

Terms and Conditions:

1. All provisions of the Solicitation and other addenda not modified herein shall remain in full force and effect.

2. Vendor should acknowledge receipt of all addenda issued for this Solicitation by completing an Addendum Acknowledgment, a copy of which is included herewith. Failure to acknowledge addenda may result in bid disqualification. The addendum acknowledgement should be submitted with the bid to expedite document processing.

ATTACHMENT A

ADDENDUM #3
7012EC10

HYDRAULIC TRACK EXCAVATOR

SPECIFICATIONS:

13 **Engine must be Tier 4**

ADDENDUM ACKNOWLEDGEMENT FORM
SOLICITATION NO.: 7012EC10

Instructions: Please acknowledge receipt of all addenda issued with this solicitation by completing this addendum acknowledgment form. Check the box next to each addendum received and sign below. Failure to acknowledge addenda may result in bid disqualification.

Acknowledgment: I hereby acknowledge receipt of the following addenda and have made the necessary revisions to my proposal, plans and/or specification, etc.

Addendum Numbers Received:

(Check the box next to each addendum received)

- | | |
|--|--|
| <input checked="" type="checkbox"/> Addendum No. 1 | <input type="checkbox"/> Addendum No. 6 |
| <input checked="" type="checkbox"/> Addendum No. 2 | <input type="checkbox"/> Addendum No. 7 |
| <input checked="" type="checkbox"/> Addendum No. 3 | <input type="checkbox"/> Addendum No. 8 |
| <input type="checkbox"/> Addendum No. 4 | <input type="checkbox"/> Addendum No. 9 |
| <input type="checkbox"/> Addendum No. 5 | <input type="checkbox"/> Addendum No. 10 |

I understand that failure to confirm the receipt of addenda may be cause for rejection of this bid. I further understand that that any verbal representation made or assumed to be made during any oral discussion held between Vendor's representatives and any state personnel is not binding. Only the information issued in writing and added to the specifications by an official addendum is binding.

STATE EQUIPMENT, INC.

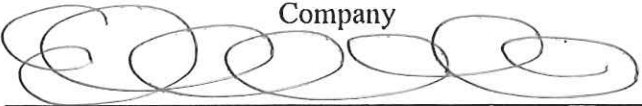
 Company

 Authorized Signature

 6-26-2012

 Date

NOTE: This addendum acknowledgement should be submitted with the bid to expedite document processing.

HYDRAULIC TRACK EXCAVATOR
SPECIFICATIONS 310-1-E

RFQ 7012EC10

I. PURPOSE AND SCOPE:

The West Virginia Division of Highways is soliciting bids to establish an open-end contract for Hydraulic Track Excavators.

II. DEFINITIONS:

The terms listed below shall have the meanings assigned to them as follows:

1. "Agency" or "Agencies" means West Virginia Division of Highways
2. "Contract" means the binding agreement that is entered into between the State and the Vendor to provide the Desired Items as specified herein.
3. "Desired Item" or "Desired Items" means the list of items identified in Section III, Subsection 1 below.
4. "Pricing Pages" means the schedule of prices, estimated order quantity, and totals attached hereto as Exhibit A and used to evaluate the RFQ.
5. "Purchasing Division" means the West Virginia Department of Administration, Purchasing Division.
6. "RFQ" means the official RFQ published by the Purchasing Division and identified as RFQ 7012EC10.
7. "State" means the State of West Virginia and/or any of its agencies, commissions, boards, etc.
8. "Vendor" or "Vendors" means the successful bidder(s).

III. GENERAL REQUIREMENTS

1. **Desired Items and Mandatory Requirements:** Vendor shall provide Agency with the Desired Items listed below. Desired Items must meet or exceed the mandatory requirements as shown in Exhibit A.
 - a. Shall be Kobelco SK135SR or equal

IV. CONTRACT AWARD

1. **Contract Award:** The Contract is intended to provide Agency with a purchase price for the Desired Item listed above. The Contract shall be awarded to the Vendor that provides the lowest overall total cost for the items listed on the Pricing Pages.

2. **Pricing Pages:** Vendor should complete the Pricing Pages by completing the Make/Model, quoting the price, and signing that you can comply with all mandatory specifications. Vendor should complete the Pricing Pages in their entirety as failure to do so may result in Vendor's bid being disqualified.

The Pricing Pages contain a list of the Desired Items and estimated purchase volume. The estimated purchase volume for each item represents the approximate volume of anticipated purchases only. No future use of the Contract or any individual item is guaranteed or implied.

Notwithstanding the foregoing, the Purchasing Division may correct errors as its discretion. Vendor should type or electronically enter the information into the Pricing Page to prevent errors in the evaluation, The Pricing Pages were created a Microsoft Excel document and Vendor can request an electronic copy for bid purposes on Purchasing's website www.state.wv.us/admin/purchase.

V. ORDERING AND PAYMENT

1. **Ordering:** Vendor shall accept orders by regular mail, facsimile, e-mail, or any other written form of communication. Vendor may, but is not required to, accept on-line orders through a secure internet ordering portal/website. If Vendor has the ability to accept on-line orders, it should include in its response a brief description of how Agencies may utilize the on-line ordering system. Any on-line ordering system must have the capability to restrict prices and available items to conform to the Catalogue originally submitted with this RFQ. Vendor shall ensure that its on-line ordering system is properly secured prior to processing Agency orders on-line.
2. **Payment:** Vendor shall accept payment in accordance with the payment procedures of the State of West Virginia.

VI. DELIVERY AND RETURN

1. **Delivery Time:** Vendor shall deliver standard orders within 90 working days after orders are received. Vendor shall deliver emergency orders within one (1) working day after orders are received. Vendor shall ship all orders in accordance with the above schedule and shall not hold orders until a minimum delivery quantity is met. A completed pilot model for inspection must be provided within 60 calendar days after receipt of the purchase agreement by the successful vendor.
2. **Late Delivery:** The Agency placing the order under this Contract must be notified in writing if orders will be delayed for any reason. Any delay in delivery that could cause harm to an Agency will be grounds for:
 - (a) Cancellation of the Contract, and
 - (b) Obtaining the Desired Item from a third party.

Any Agency seeking to obtain the Desired Items from a third party under this provision must first obtain approval of the Purchasing Division.

3. **Delivery Payment/Risk of Loss:** Standard order delivery shall be F.O.B. destination to the Agency's¹⁰ location: West Virginia Division of Highways, Equipment Division, Route 33 and Brushy Fork Road, Buckhannon, West Virginia. Vendor shall include the cost of standard order delivery charges in its bid pricing/discount and is not permitted to charge the Agency separately for such delivery. The Agency will pay delivery charges on all emergency orders provided that Vendor invoices those delivery costs as a separate charge with the original freight bill attached to the invoice.
4. **Return of Unacceptable Items:** Items that Agency deems unacceptable shall be returned to Vendor at Vendor's expense and with no restocking charge. Vendor shall either make arrangements for the return within five (5) days of being notified that items are unacceptable or permit the Agency to arrange for the return and reimburse agency for delivery expenses. The returned product shall either be replaced, or the Agency shall receive a full credit or refund for the purchase price, at the Agency's discretion.

VII. MISCELLANEOUS

1. **No Substitutions:** Vendor shall supply only Desired Items submitted in response to the RFQ. Vendor shall not supply substitute items.
2. **Vendor Supply:** Vendor must carry sufficient inventory of the Desired Items being offered to fulfill its obligations under this Contract. By signing its bid, Vendor certifies that it can supply the Desired Items contained in its bid response.
3. **Reports:** Vendor shall provide quarterly reports and annual summaries to the Agency showing the Agency's items purchased, quantities of items purchased, and total dollar value of the items purchased. Vendor shall also provide reports, upon request, showing the items purchased during the term of this Contract, the quantity purchased for each of those items, and the total value of purchases for each of those items. Failure to supply such reports may be grounds for cancellation of this Contract.
4. **Contract Manager:** During its performance of this Contract, Vendor must designate and maintain a primary contract manager responsible for overseeing Vendor's responsibilities under this Contract. The Contract manager must be available during normal business hours to address any customer service or other issues related to this Contract.
5. **Mandatory Requirements:** The terms "must", "will", "shall", "minimum", "maximum", or "is/are required" identify a mandatory contract requirement. Decisions regarding compliance with any mandatory requirements shall be at the sole discretion of the Purchasing Division. Failure on the part of the Vendor to meet any of the mandatory specifications shall result in disqualification of the bid.
6. **Waiver:** The failure of either party to insist upon a strict performance of any of the terms or provisions of this Contract, or to exercise any option, right, or remedy herein contained, shall not be construed as a waiver or a relinquishment for the future of such term, provision, option, right, or remedy, but the same shall continue in remain in full force and effect. Any waiver must be expressly stated in writing and signed by the waiving party.

EXHIBIT A

VIII. SPECIFICATIONS:

Hydraulic Track Excavator to meet or exceed the following specifications:

1. Mandatory Specifications

A mandatory pre-bid conference is scheduled for this equipment purchase as stated in the RFQ.

Vendors having products with variations or exceptions in specified mandatory items are expected to address any such variations or exceptions during the pre-bid conference.

The State shall review and consider any such variation or exception, and may at its sole discretion, issue an addendum to change mandatory specifications deemed to be in the State's best interest.

Bids from any vendor failing to attend the mandatory pre-bid shall be disqualified.

Bids containing any variation or exception to a mandatory specification that was not addressed during the pre-bid conference and accepted by the issuance of an Addendum shall be disqualified.

2. Vendor shall deliver standard orders within 90 working days after orders are received.
3. A completed pilot model for inspection must be provided within 60 calendar days after receipt of the purchase agreement by the successful vendor.
4. Vendor shall deliver emergency orders within one (1) working day after orders are received.
5. Standard order delivery shall be F.O.B. destination to the Agency's location:
West Virginia Division of Highways, Equipment Division, Route 33 and Brushy Fork Road, Buckhannon, West Virginia
6. The unit specified herein and offered to be manufactured after January 1, 2012 and be clearly identified and marked with date of manufacture.
7. Operating and Service Manuals and Parts Lists

An operator's manual must be included with each unit upon delivery.

A "line sheet" (if applicable) and Equipment Preventative Maintenance Questionnaire must be with pilot unit upon delivery.

There must be 12 service/shop/maintenance manuals; ten for the ten (10) Districts and two (2) for Equipment Division. Also must be 14 parts manuals; ten (10) for the ten (10) districts and four (4) for the Equipment Division. CD ROM is preferred in lieu of parts manuals.

Manuals shall be delivered upon completion of delivery of total units. Failure to do so will delay payment.

8. Training:

Manufacturers and/or dealers will be required to stage a thorough seminar on the subjects of Preventative Maintenance, Operator, and Mechanic Training.

In order to keep operators and mechanics updated, the successful vendor shall conduct training with each purchase order against this open end contract.

Manufacturers and/or dealers shall be required to furnish the Training Academy with one (1) Operator's Manual to be shipped direct to WVDOH Training Academy, Post Office Box 610, Buckhannon, West Virginia 26201 prior to delivery of pilot.

Seminar to be held at W. Va. Division of Highways, Equipment Division, Buckhannon, WV

9. Preventative Maintenance and Operator Procedures:

Manufacturers and/or dealers will be required to submit to the Equipment Division, in addition to the operating and service manuals, booklets and pamphlets explaining the Preventative Maintenance and Operator Procedures to be used by the operators of this equipment, and must include such things as daily prestart inspection procedure, service schedule, and routing maintenance required, safety precautions, etc.

The successful vendor shall furnish all training aids; i.e. videos, projectors, etc. required in conducting the training.

10. Warranty and Service Policy:

The unit must be accompanied upon delivery by the unit's manufacturers executed warranty or service policy.

A mandatory minimum two (2) year bumper to bumper basic parts and labor warranty regardless of hours and excluding abuse and normal wear items is required for this unit.

The Warranty and Service Policy Questionnaire must be completed in its entirety and submitted with your bid package.

13 11. Unspecified Accessories & Features

All parts, equipment, accessories, material, design and performance characteristics not specified herein, but which are necessary to provide a complete unit, must be furnished with each unit and required to conform to strength, quality of material, and quality of workmanship to those which are advertised and provided to the market in general by the unit industry.

All parts and accessories advertised and regularly supplied as standard shall be included, except those which would represent duplication of these specified and except those which, by specification, are not to be furnished.

All standard safety features, required by Federal and State Law, shall be included.

12. Operating weight shall be minimum 28,000 pounds and maximum of 33,000 pounds including fuel, thumb, and bucket attached.

13. Engine shall be 84 horsepower minimum; turbocharged diesel Tier 4

Pressurized liquid cooling system with thermostat, filled with manufacturers approved extended life permanent type anti-freeze that provides freeze protection to at least -30 degrees F.

Air cleaner, double element with auto dust evacuation.

Fuel filtering system shall be manufacturer's heaviest duty available.

Dust proof net for radiator and oil cooler should be provided.

Manufacturer's heaviest duty electrical system shall be provided.

14. Hydraulic System:

Hydraulic system to maintain manufacturers recommended safe oil temperature within recommended operating range during continuous operation under maximum working combinations.

System to have manufacturer's heaviest variable capacity piston type pumps with load sensing for maximum efficiency.

Boom length shall be minimum 15 feet and should be controlled by two (2) hydraulic cylinders.

Arm length shall be minimum 8 feet and should be controlled by one (1) hydraulic cylinder and equipped with multi function hydraulics with piping to the end of arm with foot controls. And shall include shut off valve at end of piping.

Unit shall be equipped with a hydraulic thumb minimum of 18 inches x 46 inches.

Tine thickness of thumb to be 1 inch with a pin diameter of approximately 2 inches.

Bucket to be approximately 0.60 cubic yard capacity, shall be with teeth and side cutters and controlled by one (1) hydraulic cylinder.

Drive shall be hydrostatic design with independent track control.

Wet multiple disk brakes that automatically release while propelling and apply when stationary.

Unit swing shall be capable of 360 degrees.

Swing speed should be approximately 10 R.P.M.

Swing brake shall be SAHR for safety.

Unit shall be joystick controlled with a minimum of one (1) additional actuator for auxiliary hydraulics.

15. Undercarriage:

Undercarriage frame shall be manufacturers standard for model bid.

Unit shall have sealed type track.

A minimum of one (1) top carrier roller each side for proper track support.

Track guides shall be provided to prevent track misalignment.

Track adjustment shall be of hydraulic design.

Shall have manufacturer's triple grouser shoes.

Track length minimum 11 feet.

Limited tail swing 5.1 feet including manufacturers needed weight(s)

16. Cab shall be all weather steel isolation mounted.

Unit will have a deep cushioned fully adjustable seat with padded arm rests.

Cab shall be equipped manufacturers heater and air condition system.

Cold weather starting aid shall be provided.

Cab should be equipped with front windshield wiper and washer, intermittent features.

Manufacturer's vandalism protection package shall be provided. The vandalism protection package shall include locking cab doors, locking compartments for engine and hydraulic components, locking fuel and radiator access and electrical cut-off switch. All locks except master switch shall be keyed alike.

Also to be included:

- Interior cab light.
- Work lights at boom and cab for sufficient night shift operations,
- Tinted safety glass at all locations, and
- AM and FM radio with antenna.

17. Paint:

Unit will be painted manufacturers standard color.

Manufacturers standard plant painting procedures for cleaning, degreasing, preparing, priming and painting are sufficient to meet the requirements for painting unit.

18. Vendor must certify that unit offered will meet or exceed the "Occupational Safety and Health Act or 1970" and subsequent amendments.

19. Advertising: No visible decals or name plates or painted on names representing the manufacturer or model number or trademark should appear on the exterior surface of the unit. Such logos created through the stamping or casting process of manufacture are accepted.

YEAR/MAKE/MODEL BID: 2012 CASE CX145C

LUMP SUM BID, MEETING ALL SPECIFICATIONS ABOVE: \$111,769.00 (EACH)
\$1,117,690.00 FOR 10 UNITS

I hereby certify that the item being bid meets or exceeds specifications as written and I will comply with them all:

 STATE EQUIPMENT, INC
 P.O. BOX 3939
 CHARLESTON, WV 25339
 EDDIE ROWAN, JR.

Vendor name and address and representative bidding

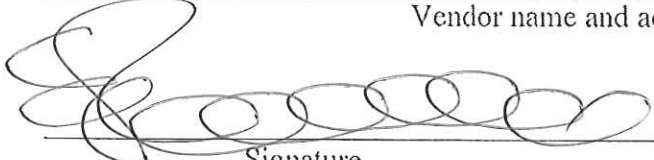

 Signature

6-26-2012
Date

EQUIPMENT PREVENTATIVE MAINTENANCE QUESTIONNAIRE

THIS FORM MUST BE COMPLETED IN ITS ENTIRETY BY SUCCESSFUL BIDDER OR MANUFACTURER'S TECHNICAL REPRESENTATIVE PRIOR TO DELIVERY OF PILOT MODEL TO THE WVDOT.

DESCRIPTION: _____ MAKE: _____

MODEL: _____ YEAR: _____ PURCHASE AMOUNT: _____

ENGINE: MAKE: _____ MODEL: _____ FUEL TYPE: _____

HORSEPOWER: _____ CYLINDER: _____ ENGINE SERIAL: _____

COOLING SYSTEM CAPACITY: _____

BELTS:	DESCRIPTION:	PART NUMBERS:
	_____	_____
	_____	_____

GVW: _____ AXLE CAPACITY: FRONT: _____ REAR: _____

TIRES: FRONT MAKE & SIZE: _____

REAR MAKE & SIZE: _____

DIMENSIONS OF UNIT: LENGTH: _____ WIDTH: _____ LENGTH: _____

VENDOR CONTACT PERSON: _____ PHONE: _____

PARTS:

BATTERY MAKE: _____ MODEL: _____ CCA: _____

TOP OR SIDE POST: _____ DIMENSIONS: LENGTH _____ WIDTH _____ HEIGHT _____

SPARK PLUGS OR FUEL INJECTORS MAKE: _____ PART #: _____

FUEL PUMP OR INJECTION PUMP MAKE: _____ MODEL: _____

ALTERNATOR MAKE: _____ PART #: _____

STARTER MAKE: _____ PART #: _____

TURBO CHARGER MAKE: _____ PART #: _____

TRANS. MAKE: _____ MODEL: _____ AUTO/MANUAL: _____

HYDRAULIC PUMP MAKE: _____ MODEL: _____

FILTERS	MAKE	PART NO.	LUBRICANT	MANUFACTURER TYPE
OIL	_____	_____	ENGINE	_____
AIR INNER	_____	_____	TRANSMISSION	_____
AIR OUTER	_____	_____	POWER STEERING	_____
FUEL PRIMARY	_____	_____	HYDRAULIC	_____
FUEL SECONDARY	_____	_____	DIFFERENTIALS	_____
COOLANT	_____	_____	BRAKE FLUID	_____
HYDRAULIC	_____	_____	COOLANT	_____
OTHER	_____	_____	OTHER	_____

WARRANTY AND SERVICE POLICY QUESTIONNAIRE

THIS FORM MUST BE COMPLETED IN ITS ENTIRETY AND SUBMITTED WITH YOUR BID.

(If additional lines are needed, make copies of form.)

1. Define the terms of the standard warranty. If not offered, so state. (Attach copy)

12 MONTHS OR 1,800 HOURS FULL MACHINE

24 MONTHS OR 2,000 HOURS-ENGINE

2. Define warranty service to be performed at DOH facilities and warranty service to be performed at manufacturer's representative facility. List name and location of manufacturer's representative.

WARRANTY SERVICE TO BE PERFORMED AT STATE EQUIPMENT, INC. FACILITIES LOCATED IN CROSS LANES, WV BRIDGEPORT, WV BEAVER, WV PARKERSGURG, WV

3. List locations for parts inventories that are within the State of West Virginia. Also, list availability levels, if known.

CROSS LANES, WV BEAVER, WV BRIDGEPORT, WV PARKERSBURG, WV

4. During the term of warranty, list the guarantee discount to manufacturer's published list price for parts that bidder will sell the parts to owner.

- A. Terms: Net 30 Manufacturer's published list price less: 0 % discount
B. Terms: Net 60 Manufacturer's published list price less: 0 % discount
C. Terms: Net 90 Manufacturer's published list price less: 0 % discount

5. During the term of warranty, will all manufacturers or engineering improvements be submitted to Division of Highways? X YES NO

6. During the term of warranty, list the guaranteed rates charged for repair to the unit.

A. Shop Rate \$ 90.00 per mechanic hour

B. Travel Time Charge \$ 90.00 per mechanic hour (Specify if one-way) ; port to port X

C. Mileage Charge \$ 2.15 per vehicle mile (Specify if one-way) ; port to port X

D. Field Mechanic Rate \$ 90.00 per mechanic hour

E. Specify period of time that prices are in effect: 12 MONTHS

F. Surcharge for miscellaneous items: 0 %

COST SHEET

Item Number	Estimated Quantity*	Unit of measure	Description	Unit Price	Extended Amount
1	10	Each	Hydraulic Track Excavator 2012 CASE CX 145C	\$111,769.00	\$1,117,690.00
			Total Amount		\$1,117,690.00



STATE EQUIPMENT, INC.

PO BOX 3939
CHARLESTON WV 25339

PHONE: 304-776-4405
FAX: 304-776-4409
INFO@STATEEQUIPMENT.COM
WWW.STATEEQUIPMENT.COM

THE CASE CX145C EXCAVATOR WILL MEET OR EXCEED THE OCCUPATIONAL
SAFETY AND HEALTH ACT OF 1970 AND SUBSEQUENT AMMENDMENT.

PURCHASED PROTECTION PLAN MASTER PARTS SCHEDULE CONSTRUCTION EQUIPMENT NEW EQUIPMENT		
<p><i>This Plan excludes protection for any failure to any component caused by or resulting from the failure of a component not listed on the "Master Parts Schedule", including any resulting damage to a "covered component". "Covered components" vary by Plan Option and are limited to those under the purchased Plan Option. See the Terms and Conditions document for complete Plan details.</i></p>		
POWERTRAIN PLAN OPTION COVERED COMPONENTS		
ENGINE and all internal lubricated components within Accessory Gears Camshaft Camshaft Bearings Camshaft Drive Gear Connecting Rods & Bearings Crankshaft Bearings & Gear Crankshaft Including Front And Rear Crankshaft Seals Cylinder Heads/ Head Gaskets Cylinder Liners Engine Block Engine Oil Cooler Engine Speed Controls, Linkages, and Cables Flywheel, Ring Gear Front And Rear Engine Covers And Seals Front Damper Oil Pan And Gasket Oil Pump Pistons & Rings Pressure/Temperature Sensors & Sending Units Rocker Arm Assembly Thermostats Timing Gears Valve Cover And Gasket Water Pumps	Engine Components Covered after Emission Warranty Charge Air Cooler Electronic Engine Control Module EGR System Manifold Injection Pump Injectors Intake and Exhaust Manifold And Gaskets Turbocharger And Gasket COMPACTION/PAVING EQUIPMENT Eccentric Mechanism & Bearings Drum Seals Propulsion System Hydraulic Components Pump Drive Reduction Unit Splitter Box Torque Hubs Vibration System Hydraulic Components TRANSMISSIONS/AXLES/HYDROSTATICS Axle Housing Axle Shaft Clutch Discs (Wet Only) Clutch Plates (Wet Only) Counter Shaft Clutch Differential Housing Differential Pinion Gear / Ring Gear Drive Axle Hub Drive Shaft with Universal Joints Drive Shaft Support Bearing Electronic Transmission Controller and Valve	TRANSMISSIONS/AXLES/HYDROSTATICS CONTINUED Enclosed Oil Immersed Chains and Sprockets Final Drive Pinion Final Drive Planetary Gears Front Wheel Drive Sensors Hydraulic Drive / Travel Motor Hydraulic Drive Pump Hydraulic Transmission-Control Valve Hydrostatic/Hydraulic Pump Drives Hydrostatic Motor Hydrostatic Transmission Charge Pump Hydrostatic Transmission Pump Internal Lubricated Clutch Housings Internal Transmission Control Linkage Internal Wet Service Brakes MFWD Axle/Differential Assembly including Driveshaft and U Joint Planetary Gear Carrier IPTO Clutch Housing (Scraper Tractors Only) Rotary Hydraulic Manifold Splitter Drive/Drop Box Swing Motor And Swing Gear Box Turntable Bearing Torque Converter Torque Converter Pump Transfer Drive Transmission Case Transmission Gears, Bearings, & Shafts Transmission Pump Travel Control Valve Travel & Swing Sections (only) Of Main Control Valve Wet Steering Clutches
POWERTRAIN EXCLUSIONS		
<p><i>Engine/Transmission Mounts, Hoses And Fittings, Filters, Belts, Pulleys, Lubricants, Antifreeze, Burnt And/Or Pitted Valves, Radiator, Wiring Harnesses, Breathers, Adjustments, Dry Clutches, Batteries, Electrical Components Not Listed Above, Pipes, And Gauges*</i></p>		
POWERTRAIN PLUS HYDRAULIC PLAN OPTION COVERED COMPONENTS		
All components listed under the Powertrain Plan Option, plus:		
Accumulator And Related Relief Valve Brake Accumulator Brake Pressure Sensor Brake Pump, Brake Valve Differential Lock Valve Fan Pumps And Motors	Hydraulic Cylinders Hydraulic Hoses and Piping Hydraulic Motors Hydraulic Oil Coolers Hydraulic Pumps	Hydraulic Reservoir Hydraulic Valves Pilot Control Pressure Reducing Valves Unloading Valves
POWERTRAIN PLUS HYDRAULIC EXCLUSIONS		
<p><i>All Powertrain Exclusions, (except Hydraulic Hoses and Fittings), plus Air and Water Hoses (Including Fittings), External Hydraulic Seals, External O-Rings And Bonded Washers, Hydraulic Quick Couplers, O1, Filters, Breathers, Hose Chafing, and Adjustments*</i></p>		
PREMIER PLAN OPTION COVERED COMPONENTS		
All components listed under the Powertrain and Powertrain + Hydraulics Plan Options, plus:		
ENGINE Engine Mounts And Supports Filter Mount Fuel Lines Fuel Tank Fuel Transfer Pump & Gasket Oil Filler Tube Oil Lines Pulleys Radiator Water Piping Fan And Fan Drive Air Intake Hose Engine Components Covered after Emission Warranty Catalytic Converter Diesel Particulate Filter Selective Catalytic Reduction System Diesel Exhaust Fluid Tank and Dispensing System Cold Start Enrichment Systems Sensors, Solenoids & Wiring Harnesses used in these systems	FACTORY INSTALLED HEAT AND AIR CONDITIONING Accumulator Clutch Compressor Condenser Dryer Evaporator Expansion Valve Heater Core Hoses Pulley Seals & Gaskets Temperature Control Programmers and Valves TRANSMISSION / AXLES / HYDROSTATICS Control Rods External Oil Lines Filler Tubes (Transmission) Pneumatic Valves Undercarriage Roller And Idler Seals And Bearings Undercarriage Tensioners UNDERCARRIAGE EXCLUSIONS: ... Sprocket, Tracks, Pads, Bolts, Chains, Or Any Failure Due To Wear, Or Breakage Caused By Wear	ELECTRICAL Alternator Gauges Horn Indicators Instruments Electronic Joysticks Electric Motors Sensors Solenoid Valves Starter And Starter Solenoid Switches Traction Control System Voltage Regulator Wiring Harnesses Wiring Harnesses Exclusions ... Rubbing, Chafing, Loose Or Corroded Connections STRUCTURAL Backhoe Booms Backhoe/Excavator Dipper Sticks Excavator Booms Wheel Loader/Skid steer Loader Arms
PREMIER EXCLUSIONS		
<p><i>Filters, Belts, Lubricants, Antifreeze, Burnt And/Or Pitted Valves, Breathers, Batteries, Electrical Components Not Listed Above, External Hydraulic Seals, Dry Clutches, External O-Rings And External Bonded Washers, Hydraulic Quick Couplers, Hose Chafing, and Adjustments*</i></p>		

20110102_cnhcon_mps_us_en_new_vb

Program may not be available in all states or provinces. Eligible equipment or other program details may vary by state or province based on state or provincial regulations. This literature is descriptive only. The precise protection afforded is subject to the terms, conditions and exclusions of the contract as issued. Program participation is subject to customer credit qualification and/or other underwriting requirements. Programs may be changed or cancelled without notice. Capitalized terms used in this literature, unless defined herein, have the meanings assigned to them in the contract as issued.

PURCHASED PROTECTION PLAN MASTER PARTS SCHEDULE CONSTRUCTION EQUIPMENT NEW EQUIPMENT		
<p><i>This Plan excludes protection for any failure to any component caused by or resulting from the failure of a component not listed on the "Master Parts Schedule", including any resulting damage to a "covered component". "Covered components" vary by Plan Option and are limited to those under the purchased Plan Option. See the Terms and Conditions document for complete Plan details.</i></p>		
STRUCTURAL PLAN OPTION COVERED COMPONENTS		
<p>This is a stand-alone plan option and must be purchased separately</p>		
Backhoe Booms	Engine Frame	Main Frame
C Frame	Equipment Frame	Moldboard Lift Arm
Car Body	Excavator Booms	Rollover Protection Structure (ROPS)
Chassis	Forklift Masts	Swing Frame
Circle Frame	Loader Arms	Track Frame
Dipper Stick		
STRUCTURAL EXCLUSIONS		
<p><i>Pivot Pins, Forks, Carriages, Swingpost, Pivot Pin Bushings, Loader/Backhoe Links, 3-Point Hitch Linkage, Extending Dipper Wear Strips, Deterioration Due To Use Of Non Factory Approved Attachments, Front Shovels/Buckets, Backhoe Buckets, Including Teeth/Side-Cutters, Wear Pads, Hose Routing Guides *</i></p>		
BACKHOE STRUCTURAL PLAN OPTION COVERED COMPONENTS		
<p>This is a stand-alone plan option and must be purchased separately</p>		
<p>Backhoe Main Boom Standard Dipper Arms Inner and Outer Dipper Arms of the Extendable Boom Swing Tower Castings</p>		

20110102_cnhcon_mps_us_en_new_vb

Program may not be available in all states or provinces. Eligible equipment or other program details may vary by state or province based on state or provincial regulations. This literature is descriptive only. The precise protection afforded is subject to the terms, conditions and exclusions of the contract as issued. Program participation is subject to customer credit qualification and/or other underwriting requirements. Programs may be changed or cancelled without notice. Capitalized terms used in this literature, unless defined herein, have the meanings assigned to them in the contract as issued.

ENGINE

Model	Isuzu AM-4JJ1X Tier 4 Interim Certified (Cooled EGR)
Fuel	Requires ultra low-sulfur fuel B5 biodiesel tolerant
Type	Water-cooled, 4-cycle, high pressure common rail system. Turbo-charged with air cooled intercooler, DPD system
Cylinders	4-cylinder in-line
Displacement	183 in ³ (3.0 L)
Bore / Stroke	3.76 in x 4.13 in (95.4 mm x 104.9 mm)
Fuel injection	Direct injection (electronic)
Fuel filter	Replaceable, full flow spin-on cartridge
Air filter	Dry type element w/ warning restriction indicator
Oil filter	Replaceable, full flow spin-on cartridge
Engine oil operating angle ratings:	
Side-to-side	Rated 35° slope
Fore and aft	Rated 35° slope
Net horsepower—SAE J1349	100 hp (74.9 kW) @ 2000 RPM
Net maximum torque—SAE J1349	265 lb-ft (359 N·m) @ 1600 RPM
Cooling	110° to -13°F (43° to -25°C) at 55% concentration
Oil	Requires low-ash oil (CJ-4)

SERVICE CAPACITIES

Fuel tank	53 gal (320 L)
Hydraulic system	42 gal (252 L)
Hydraulic tank	20 gal (114 L)
Engine oil w/ filter	4.5 gal (23.1 L)
Swing drive	3.2 qt (5.0 L)
Final drive (each side)	2.4 qt (5.0 L)
Cooling system	4.0 gal (15.3 L)

ELECTRICAL

Voltage	24 Volts
Alternator rating	50 amp
Batteries	2 x 12 Volt
Battery reserve capacity	72 Ah / 5 hour
Work lights (4)	24 Volt / 70 watt (1 x boom; 1 x upper; 2 x cab)

SWING MECHANISM

Swing speed	0 – 10.6 RPM
Swing torque	27,400 lb-ft (37,000 N·m)
Swing brake	Mechanical disc

UNDERCARRIAGE

Length	12 ft 4 in (3.76 m)
Track gauge	6 ft 6 in (1.99 m)
Carrier rollers	2 per side
Track rollers	7 per side
Shoes—triple grouser	47 per side
Shoe width (std.)	23.6 in (600 mm)
Link pitch	6.8 in (172 mm)
Track:	
Chain	Grease lubricated / strutted
Guides	Single
Adjustment	Hydraulic

GROUND PRESSURE

@ Standard operating weight	5.22 psi (.36 bar)
w/ 23.6 in (600 mm) triple semi-grouser shoes	

HYDRAULICS

System design	Open center
Main pumps	Two variable displacement/ axial pistons
Max. rated flow	2 x 34.1 gpm (2 x 129 L/min)
System pressures:	
Boom, arm & bucket	4,970 psi (350 bar)
Boom, arm & bucket w/ power boost	5,260 psi (370 bar)
Travel circuits	4,970 psi (350 bar)
Swing circuits	4,060 psi (286 bar)
Pilot pump	1 x gear design
Max. capacity	5.3 gpm (20 L/min)
Controls with boom/arm holding valve	
Right track travel, bucket, boom and arm acceleration.	Four-spool section
Left track travel, auxiliary, swing, boom acceleration.	Five-spool section

Work Mode Selections	SP: Speed priority H: Heavy duty A: Automatic
----------------------	---

Swing motor	Fixed displacement axial piston
Swing final drive	Planetary gear reduction
Travel motor	Two-speed independent travel/axial piston

HYDRAULIC CYLINDERS

Boom cylinders	Two (2)
Cylinder bore	4.1 in (105 mm)
Cylinder rod diameter	3.0 in (75 mm)
Cylinder stroke	44.1 in (1120 mm)
Arm cylinder	One (1)
Cylinder bore	4.5 in (115 mm)
Cylinder rod diameter	3.3 in (85 mm)
Cylinder stroke	43.6 in (1108 mm)
Bucket cylinder	One (1)
Cylinder bore	3.7 in (95 mm)
Cylinder rod diameter	2.6 in (65 mm)
Cylinder stroke	34.7 in (881 mm)

DRIVETRAIN

Travel control	Dual stage relief / counter balance design
Brakes	Mechanical disc
Service brakes	SAHR disc (each motor)
Two speed travel:	
Max. high speed	3.5 mph (5.6 kph)
Max. low speed	2.1 mph (3.2 kph)
Automatic downshift	
Drawbar pull	26,100 lbf (116 kN)
Gradeability	70% (35° slope)

CAB AND CONTROLS

Air-conditioner output	18,100 BTU/hr
Heater output	20,150 BTU/hr
Sound level—ISO6395 (inside cab)	70 dBA
Electrical outlet	12 Volt
Cab interior light (1)	10 watt
Rear-view camera (1)	Standard
Seat	Air-suspension

ATTACHMENTS

Boom	15 ft 2 in (4.63 m)
Arm options	8 ft 2 in (2.50 m)
Bucket digging force*	20,200 lbf (90 kN)
w/ Auto Power-Boost	21,400 lbf (95 kN)

*Digging force ratings based on ISO6015

OPERATING WEIGHT

Operating weight	31,967 lb (14,500 kg)
w/ shoes	23.6 in (600 mm)
w/ boom	15 ft 2 in (4.72 m)
w/ arm	8 ft 2 in (2.50 m)
w/ bucket	880 lb (400 kg)
w/ counterweight	8,160 lb (3,700 kg)
w/ operator / full fuel / standard equipment	

CX145C SR LC LIFT CAPACITIES

8 ft 2 in (2.50 m) Arm Lift capacities calculated using a 900 lb (408 kg) bucket, 8,160 lb (3700 kg) counterweight and 23.6 in (600mm) shoes.

Load (Lift Point) Height	5 ft (1.5 m)		10 ft (3 m)		15 ft (4.5 m)		20 ft (6 m)		25 ft (7.5 m)		MAXIMUM REACH			
	END	SIDE	END	SIDE	END	SIDE	END	SIDE	END	SIDE	@	END	SIDE	
+25 ft (7.5 m)					4,850 lb* (2200 kg)*	4,850 lb* (2200 kg)*						16 ft 8 in (5.08 m)	2,950 lb* (1338 kg)*	2,950 lb* (1338 kg)*
+20 ft (6 m)					6,350 lb* (2880 kg)*	6,350 lb* (2880 kg)*	4,800 lb* (2177 kg)*	4,800 lb* (2177 kg)*				21 ft 9 in (6.63 m)	2,500 lb* (1134 kg)*	2,500 lb* (1134 kg)*
+15 ft (4.5 m)					8,050 lb* (3651 kg)*	7,700 lb (3493 kg)	6,400 lb* (2903 kg)*	4,750 lb (2155 kg)				24 ft 7 in (7.49 m)	2,350 lb* (1066 kg)*	2,350 lb* (1066 kg)*
+10 ft (3 m)	28,250 lb* (12 814 kg)*	28,250 lb* (12 814 kg)*	15,700 lb* (7121 kg)*	14,250 lb (6464 kg)	10,350 lb (4695 kg)	7,350 lb (3334 kg)	6,400 lb (2903 kg)	4,550 lb (2064 kg)	4,350 lb (1973 kg)	3,050 lb (1383 kg)		26 ft 0 in (7.92 m)	2,350 lb* (1066 kg)*	2,350 lb* (1066 kg)*
+5 ft (1.5 m)			19,750 lb (8958 kg)	12,900 lb (5851 kg)	9,800 lb (4445 kg)	6,850 lb (3107 kg)	6,150 lb (2790 kg)	4,300 lb (1950 kg)	4,250 lb (1928 kg)	2,950 lb (1338 kg)		26 ft 3 in (8.00 m)	2,500 lb* (1134 kg)*	2,500 lb* (1134 kg)*
Ground-line	6,250 lb* (2835 kg)*	6,250 lb* (2835 kg)*	18,500 lb (8391 kg)	11,900 lb (5398 kg)	9,300 lb (4218 kg)	6,400 lb (2903 kg)	5,900 lb (2676 kg)	4,100 lb (1860 kg)	4,150 lb (1882 kg)	2,850 lb (1293 kg)		25 ft 6 in (7.77 m)	2,800 lb* (1270 kg)*	2,750 lb (1247 kg)
-5 ft (-1.5 m)	11,500 lb* (5216 kg)*	11,500 lb* (5216 kg)*	18,450 lb (8369 kg)	11,800 lb (5352 kg)	9,100 lb (4128 kg)	6,200 lb (2812 kg)	5,800 lb (2631 kg)	4,000 lb (1814 kg)				23 ft 8 in (7.21 m)	3,350 lb* (1520 kg)*	3,100 lb (1406 kg)
-10 ft (-3 m)	18,300 lb* (8301 kg)*	18,300 lb* (8301 kg)*	17,300 lb* (7847 kg)*	12,050 lb (5466 kg)	9,200 lb (4173 kg)	6,300 lb (2858 kg)	5,900 lb (2676 kg)	4,100 lb (1860 kg)				20 ft 5 in (6.22 m)	4,650 lb* (2109 kg)*	3,950 lb (1792 kg)
-15 ft (-4.5 m)			9,400 lb* (4264 kg)*	9,400 lb* (4264 kg)*	5,000 lb* (2268 kg)*	5,000 lb* (2268 kg)*						15 ft 1 in (4.59 m)	4,750 lb* (2155 kg)*	4,750 lb* (2155 kg)*

9 ft 10 in (3.01 m) Arm Lift capacities calculated using a 750 lb (340 kg) bucket, 8,160 lb (3700 kg) counterweight and 23.6 in (600mm) shoes.

Load (Lift Point) Height	5 ft (1.5 m)		10 ft (3 m)		15 ft (4.5 m)		20 ft (6 m)		25 ft (7.5 m)		MAXIMUM REACH			
	END	SIDE	END	SIDE	END	SIDE	END	SIDE	END	SIDE	@	END	SIDE	
+25 ft (7.5 m)					5,200 lb* (2359 kg)*	5,200 lb* (2359 kg)*						19 ft 2 in (5.84 m)	2,900 lb* (1315 kg)*	2,900 lb* (1315 kg)*
+20 ft (6 m)					6,050 lb* (2744 kg)*	6,050 lb* (2744 kg)*	5,000 lb* (2268 kg)*	5,000 lb* (2268 kg)*				23 ft 8 in (7.21 m)	2,500 lb* (1134 kg)*	2,500 lb* (1134 kg)*
+15 ft (4.5 m)					6,800 lb* (3084 kg)*	6,800 lb* (3084 kg)*	5,850 lb* (2654 kg)*	4,900 lb (2223 kg)	4,050 lb* (1837 kg)*	3,200 lb (1451 kg)		26 ft 3 in (8.00 m)	2,400 lb* (1089 kg)*	2,400 lb* (1089 kg)*
+10 ft (3 m)			9,950 lb* (4513 kg)*	9,950 lb* (4513 kg)*	9,250 lb* (4196 kg)*	7,550 lb (3425 kg)	6,550 lb (2971 kg)	4,650 lb (2109 kg)	4,450 lb (2018 kg)	3,100 lb (1406 kg)		27 ft 6 in (8.38 m)	2,400 lb* (1089 kg)*	2,400 lb* (1089 kg)*
+5 ft (1.5 m)			19,500 lb* (8845 kg)*	13,300 lb (6033 kg)	9,950 lb (4513 kg)	6,950 lb (3152 kg)	6,200 lb (2812 kg)	4,400 lb (1996 kg)	4,300 lb (1950 kg)	3,000 lb (1361 kg)		27 ft 10 in (8.48 m)	2,550 lb* (1157 kg)*	2,450 lb (1111 kg)
Ground-line	6,300 lb* (2858 kg)*	6,300 lb* (2858 kg)*	18,700 lb (8482 kg)	12,000 lb (5443 kg)	9,350 lb (4241 kg)	6,450 lb (2926 kg)	5,950 lb (2699 kg)	4,100 lb (1860 kg)	4,150 lb (1882 kg)	2,850 lb (1293 kg)		27 ft 1 in (8.25 m)	2,800 lb* (1270 kg)*	2,500 lb (1134 kg)
-5 ft (-1.5 m)	10,500 lb* (4763 kg)*	10,500 lb* (4763 kg)*	18,200 lb (8255 kg)	11,650 lb (5284 kg)	9,050 lb (4105 kg)	6,150 lb (2790 kg)	5,800 lb (2631 kg)	3,950 lb (1792 kg)	4,100 lb (1860 kg)	2,800 lb (1270 kg)		25 ft 4 in (7.72 m)	3,350 lb* (1520 kg)*	2,750 lb (1247 kg)
-10 ft (-3 m)	15,550 lb* (7053 kg)*	15,550 lb* (7053 kg)*	18,250 lb (8278 kg)	11,800 lb (5352 kg)	9,100 lb (4128 kg)	6,200 lb (2812 kg)	5,850 lb (2654 kg)	4,050 lb (1837 kg)				22 ft 4 in (6.81 m)	4,400 lb* (1996 kg)*	3,400 lb (1542 kg)
-15 ft (-4.5 m)	19,050 lb* (8641 kg)*	19,050 lb* (8641 kg)*	12,450 lb* (5647 kg)*	11,900 lb (5398 kg)	8,150 lb* (3697 kg)*	6,400 lb (2903 kg)						17 ft 7 in (5.36 m)	5,200 lb* (2359 kg)*	5,000 lb (2268 kg)

NOTE: *Lift capacities do not exceed 75% of the minimum tipping load or 87% of the hydraulic lift capacity. Capacities that are marked with an asterisk are hydraulic limited.

CX145C SR LC LIFT CAPACITIES

6 ft 10 in (2.11 m) HD Arm (used with offset boom only) *Lift capacities calculated using a 900 lb (408 kg) bucket, 8,160 lb (3700 kg) counterweight and 23.6 in (600mm) shoes.*

Load (Lift Point) Height	5 ft (1.5 m)		10 ft (3 m)		15 ft (4.5 m)		20 ft (6 m)		25 ft (7.5 m)		MAXIMUM REACH		
	END	SIDE	END	SIDE	END	SIDE	END	SIDE	END	SIDE	@	END	SIDE
+25 ft (7.5 m)			3,800 lb* (1724 kg)*	3,800 lb* (1724 kg)*							14 ft 7 in (4.45 m)	3,650 lb* (1656 kg)*	3,650 lb* (1656 kg)*
+20 ft (6 m)					6,900 lb* (3130 kg)*	6,900 lb* (3130 kg)*	3,800 lb* (1724 kg)*	3,800 lb* (1724 kg)*			20 ft 4 in (6.19 m)	3,000 lb* (1361 kg)*	3,000 lb* (1361 kg)*
+15 ft (4.5 m)			10,000 lb* (4536 kg)*	10,000 lb* (4536 kg)*	9,450 lb* (4286 kg)*	7,650 lb (3470 kg)	6,500 lb (2948 kg)	4,650 lb (2109 kg)			23 ft 4 in (7.11 m)	2,800 lb* (1270 kg)*	2,800 lb* (1270 kg)*
+10 ft (3 m)			17,450 lb* (7915 kg)*	14,050 lb (6373 kg)	10,200 lb (4627 kg)	7,200 lb (3266 kg)	6,300 lb (2858 kg)	4,450 lb (2018 kg)			24 ft 10 in (7.57 m)	2,800 lb* (1270 kg)*	2,800 lb* (1270 kg)*
+5 ft (1.5 m)			19,250 lb (8732 kg)	12,450 lb (5647 kg)	9,600 lb (4354 kg)	6,650 lb (3016 kg)	6,050 lb (2744 kg)	4,200 lb (1905 kg)	3,400 lb* (1542 kg)*	2,850 lb (1293 kg)	25 ft 1 in (7.64 m)	2,950 lb* (1338 kg)*	2,800 lb (1270 kg)
Ground- line			17,600 lb* (7983 kg)*	11,700 lb (5307 kg)	9,150 lb (4150 kg)	6,250 lb (2835 kg)	5,850 lb (2654 kg)	4,000 lb (1814 kg)			24 ft 4 in (7.42 m)	3,300 lb* (1497 kg)*	2,950 lb (1338 kg)
-5 ft (-1.5 m)	12,450 lb* (5647 kg)*	12,450 lb* (5647 kg)*	18,400 lb* (8346 kg)*	11,800 lb (5352 kg)	9,050 lb (4105 kg)	6,150 lb (2790 kg)	5,800 lb (2631 kg)	4,000 lb (1814 kg)			22 ft 4 in (6.81 m)	4,000 lb* (1814 kg)*	3,350 lb (1520 kg)
-10 ft (-3 m)	18,750 lb* (8505 kg)*	18,750 lb* (8505 kg)*	15,450 lb* (7008 kg)*	12,050 lb (5466 kg)	9,200 lb (4173 kg)	6,350 lb (2880 kg)					18 ft 11 in (5.77 m)	5,700 lb* (2585 kg)*	4,450 lb (2018 kg)

NOTE: *Lift capacities do not exceed 75% of the minimum tipping load or 87% of the hydraulic lift capacity.
Capacities that are marked with an asterisk are hydraulic limited.

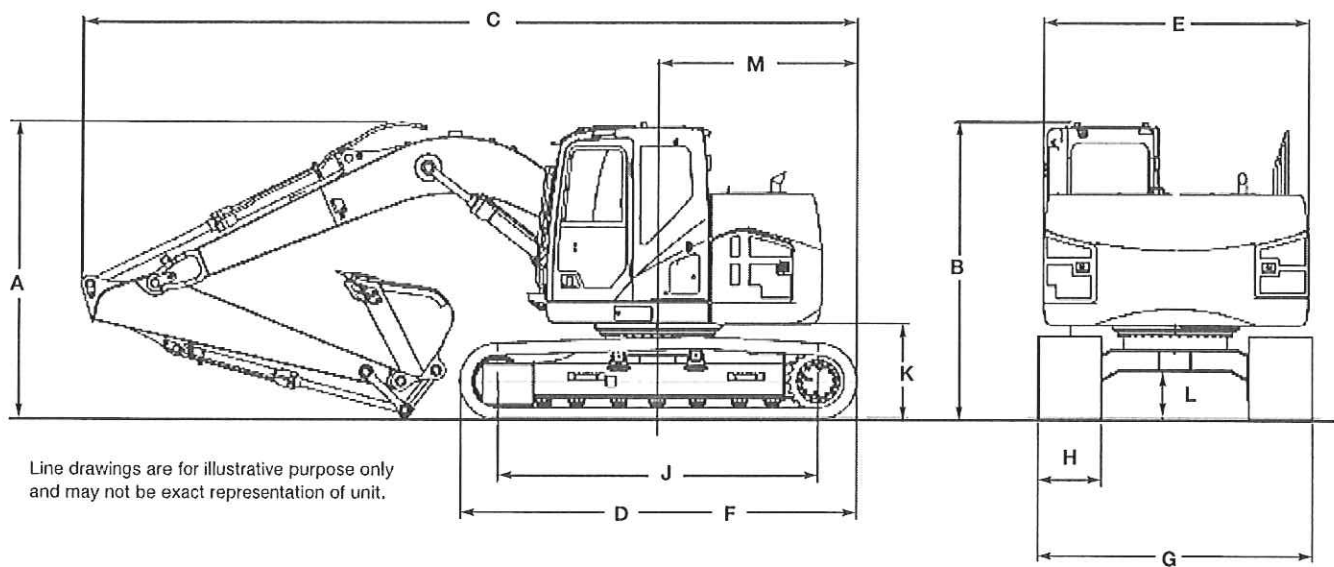

DIMENSIONS

	8 ft 2 in (2.50 m) Arm	9 ft 10 in (3.01 m) Arm	6 ft 10 in (2.11 m) HD Arm**
A. Overall height (w/ attachment)	9 ft 2 in (2.80 m)	9 ft 2 in (2.80 m)	9 ft 2 in (2.80 m)
B. Cab height	9 ft 2 in (2.80 m)	9 ft 2 in (2.80 m)	9 ft 2 in (2.80 m)
C. Overall length (w/ attachment)	24 ft 1 in (7.35 m)	23 ft 10 in (7.31 m)	24 ft 1 in (7.34 m)
D. Overall length (w/o attachment)	14 ft 7 in (3.76 m)	14 ft 7 in (3.76 m)	14 ft 7 in (3.76 m)
E. Width of upperstructure	9 ft 8 in (2.49 m)	9 ft 8 in (2.49 m)	9 ft 8 in (2.49 m)
F. Track overall length	12 ft 4 in (3.76 m)	12 ft 4 in (3.76 m)	12 ft 4 in (3.76 m)
G. Track overall width w/ 23.6 in (600 mm) shoes	8 ft 5 in (2.59 m)	8 ft 5 in (2.59 m)	8 ft 5 in (2.59 m)
H. Track shoe width	23.6 in (600 mm)	23.6 in (600 mm)	23.6 in (600 mm)
J. Center to center (idler to sprocket)	9 ft 10 in (2.9 m)	9 ft 10 in (2.9 m)	9 ft 10 in (2.9 m)
K. Upperstructure ground clearance	2 ft 9 in (0.88 m)	2 ft 9 in (0.88 m)	2 ft 9 in (0.88 m)
L. Minimum ground clearance	17 in (0.44 m)	17 in (0.44 m)	17 in (0.44 m)
M. Rear tail swing radius	5 ft 1 in (1.55 m)	5 ft 1 in (1.55 m)	5 ft 1 in (1.55 m)
Operating weight*	31,900 lb (14 500 kg)	32,830 lb (14 887 kg)	33,735 lb (15 302 kg)
Ground pressure	5.2 psi (.36 bar)	5.2 psi (.36 bar)	5.4 psi (.37 bar)

*With 23.6 in (600 mm) track shoe, 880 lb (400 kg) bucket, 165 lb (75 kg) operator, full fuel and standard equipment.

**With offset boom only.

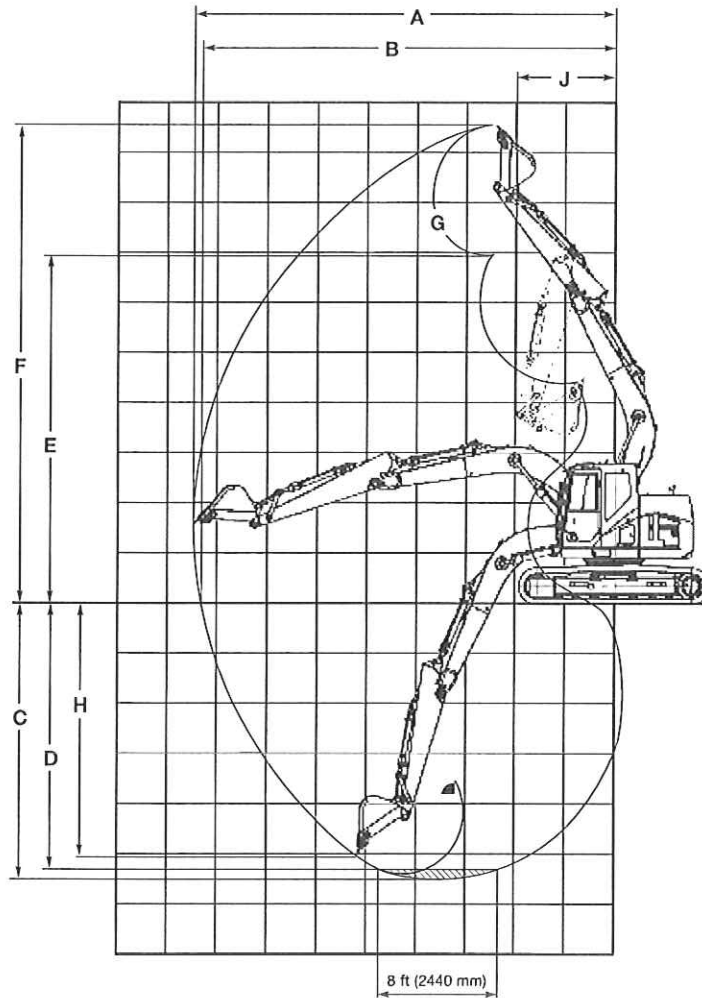

PERFORMANCE SPECS

	8 ft 2 in (2.50 m) Arm	9 ft 10 in (3.01 m) Arm	6 ft 10 in (2.11 m) HD Arm*
A. Maximum dig radius	27 ft 2 in (8.29 m)	28 ft 7 in (8.74 m)	26 ft 1 in (7.94 m)
B. Maximum dig radius at groundline	26 ft 7 in (8.14 m)	28 ft 2 in (8.60 m)	25 ft 5 in (7.78 m)
C. Maximum dig depth	18 ft 1 in (5.51 m)	19 ft 8 in (6.01 m)	16 ft 8 in (5.11 m)
D. Dig depth—8 ft 0 in (2.44 m) level bottom	17 ft 4 in (5.29 m)	19 ft 1 in (5.83 m)	15 ft 10 in (4.87 m)
E. Dump height	22 ft 8 in (6.94 m)	23 ft 9 in (7.29 m)	21 ft 9 in (6.66 m)
F. Maximum reach height	30 ft 6 in (9.34 m)	34 ft 8 in (9.69 m)	29 ft 7 in (9.06 m)
G. Bucket rotation	178°	178°	178°
H. Maximum vertical wall dig depth	16 ft 1 in (4.90 m)	17 ft 4 in (5.29 m)	14 ft 10 in (4.56 m)
J. Minimum swing radius	6 ft 4 in (1.95 m)	7 ft 6 in (2.33 m)	6 ft 2 in (1.89 m)
Arm digging force:			
Standard	13,900 lb (62 kN)	12,600 lb (56 kN)	15,700 lb (70 kN)
Power Boost	14,800 lb (66 kN)	13,500 lb (60 kN)	16,600 lb (74 kN)
Bucket digging force:			
Standard	20,200 lb (90 kN)	20,200 lb (90 kN)	20,200 lb (90 kN)
Power Boost	21,400 lb (95 kN)	21,400 lb (95 kN)	21,400 lb (95 kN)

*With offset boom only.

STANDARD EQUIPMENT

ENGINE

Isuzu four-cylinder turbo-charged diesel
Tier 4 Interim Certified (CEGR)
Electronic fuel injection
High pressure common rail system
Diesel Particulate Defuser System (DPD)
Neutral safety start
Auto-engine warm up
Glow-plug pre-heat
EPF (Engine Protection Feature)
Dual-stage fuel filtration
Dual element air filter
Remote oil filter
Green plug oil drain
500-hour engine oil change interval
24-volt system
Requires CJ-4 engine oil
Requires ultra-low sulfur fuel

FUEL ECONOMY SYSTEMS

Engine Idle / Fuel Economy System:
Auto-idle
One-touch idle
Idle shut-down
BEC—Boom Economy Control
AEC—Auto Economy Control
SWC—Swing Relief Control
SSC—Spool Stroke Control

HYDRAULICS

Auto power boost
Auto swing priority
Auto travel speed change
Selectable work modes
ISO pattern controls

OPTIONAL EQUIPMENT

HYDRAULICS

Auxiliary hydraulics:
Single acting / joystick activated
Double acting / joystick activated
Multi-function / joystick activated
Secondary low-flow / joystick activated

ATTACHMENTS

Standard arm—9 ft 11 in (3.01 m)
Heavy-duty arm—6 ft 10 in (2.11 m)
Coupler / Case multi-pin grabber
Buckets:
Heavy-duty
Extreme-duty
Load holding control
Free swing (order kit through Service Parts)
Hose Burst Check Valve (HBCV)

HYDRAULICS (continued)

Pre-set auxiliary pump settings
Auxiliary valve
5,000-hour hydraulic oil change interval
1,000-hour hydraulic filter change interval
SAHR brake

UPPERSTRUCTURE

Right and left side mirrors
Isolation mounted cab (fluid and spring)
Common key vandal locks
Upper mounted work light (70 watt)
Swivel guard belly pan

ATTACHMENTS

Boom—15 ft 6 in (4.72 m)
Arm—8 ft 2 in (2.50 m)
Heavy-duty bucket linkage
Boom mounted work light (70 watt)
Auxiliary pipe brackets
Centralized grease fittings
Attachment cushion valve
Arm and boom regeneration

OPERATOR STATION

ROPS protection
FOPS cab top guard (Level 1)
Pressurized cab
One-touch lock front window
AC/heat/defrost with auto climate control
Color monitor—7 in (180 mm)
Interior dome light
Air-suspension seat (cloth)
Seatbelt (3 in)
Adjustable armrests

OPERATOR STATION (continued)

Tilting consoles—4-position
Low-effort joystick controls
Sliding cockpit—7 in (180 mm)
Straight travel
AM/FM radio w/ antenna and 2 speakers
Aux-in port for personal electronics
Rear-view camera
Anti-theft system (start code system)
Rubber floor mat
12-volt electric outlet
24-volt cigarette lighter
External rearview mirrors
Windshield wiper / washer
Clear (polycarbonate) roof window w/ sunshade
Cup holder
Storage compartments
On-board diagnostic system
Travel alarm with cancel switch
One key start and lock-up

UNDERCARRIAGE

23.6 in (600 mm) steel shoes, triple semi-grouser
Full overlap turntable bearing tub
Hydraulic track adjustment
X-pattern carbody

OPERATOR STATION

Control pattern selector
FOPS cab top guard (Level 2)
Front grill guard—2 x 2 screen mesh
Front rock guard—vertical bars
(two piece) / OPG 1
Front rock guard—vertical bars
(fixed/one piece) / OPG 2
Vandal guard
Rain deflector
Sun visor
Side-view camera
Refueling pump

UNDERCARRIAGE

27.6 in (700 mm) steel shoes, triple semi-grouser
20.0 in (500 mm) rubber shoes
Double track chain guides

This page intentionally left blank.



NOTE: All specifications are stated in accordance with SAE Standards or Recommended Practices, where applicable.

NOTE: All engines meet current EPA emissions requirements.

IMPORTANT: Case Construction Equipment Inc. reserves the right to change these specifications without notice and without incurring any obligation relating to such change. Case Construction Equipment Inc. does not warrant the safety or reliability of attachments from other manufacturers.

Case is a registered trademark of CNH America LLC. Any trademarks referred to herein, in association with goods and/or services of companies other than CNH America LLC, are the property of those respective companies.



www.casece.com

State of West Virginia VENDOR PREFERENCE CERTIFICATE

Certification and application* is hereby made for Preference in accordance with *West Virginia Code*, §5A-3-37. (Does not apply to construction contracts). *West Virginia Code*, §5A-3-37, provides an opportunity for qualifying vendors to request (at the time of bid) preference for their residency status. Such preference is an evaluation method only and will be applied only to the cost bid in accordance with the *West Virginia Code*. This certificate for application is to be used to request such preference. The Purchasing Division will make the determination of the Resident Vendor Preference, if applicable.

- 1. **Application is made for 2.5% resident vendor preference for the reason checked:**
 Bidder is an individual resident vendor and has resided continuously in West Virginia for four (4) years immediately preceding the date of this certification; or,
 Bidder is a partnership, association or corporation resident vendor and has maintained its headquarters or principal place of business continuously in West Virginia for four (4) years immediately preceding the date of this certification; or 80% of the ownership interest of Bidder is held by another individual, partnership, association or corporation resident vendor who has maintained its headquarters or principal place of business continuously in West Virginia for four (4) years immediately preceding the date of this certification; or,
 Bidder is a nonresident vendor which has an affiliate or subsidiary which employs a minimum of one hundred state residents and which has maintained its headquarters or principal place of business within West Virginia continuously for the four (4) years immediately preceding the date of this certification; or,
- 2. **Application is made for 2.5% resident vendor preference for the reason checked:**
 Bidder is a resident vendor who certifies that, during the life of the contract, on average at least 75% of the employees working on the project being bid are residents of West Virginia who have resided in the state continuously for the two years immediately preceding submission of this bid; or,
- 3. **Application is made for 2.5% resident vendor preference for the reason checked:**
 Bidder is a nonresident vendor employing a minimum of one hundred state residents or is a nonresident vendor with an affiliate or subsidiary which maintains its headquarters or principal place of business within West Virginia employing a minimum of one hundred state residents who certifies that, during the life of the contract, on average at least 75% of the employees or Bidder's affiliate's or subsidiary's employees are residents of West Virginia who have resided in the state continuously for the two years immediately preceding submission of this bid; or,
- 4. **Application is made for 5% resident vendor preference for the reason checked:**
 Bidder meets either the requirement of both subdivisions (1) and (2) or subdivision (1) and (3) as stated above; or,
- 5. **Application is made for 3.5% resident vendor preference who is a veteran for the reason checked:**
 Bidder is an individual resident vendor who is a veteran of the United States armed forces, the reserves or the National Guard and has resided in West Virginia continuously for the four years immediately preceding the date on which the bid is submitted; or,
- 6. **Application is made for 3.5% resident vendor preference who is a veteran for the reason checked:**
 Bidder is a resident vendor who is a veteran of the United States armed forces, the reserves or the National Guard, if, for purposes of producing or distributing the commodities or completing the project which is the subject of the vendor's bid and continuously over the entire term of the project, on average at least seventy-five percent of the vendor's employees are residents of West Virginia who have resided in the state continuously for the two immediately preceding years.

Bidder understands if the Secretary of Revenue determines that a Bidder receiving preference has failed to continue to meet the requirements for such preference, the Secretary may order the Director of Purchasing to: (a) reject the bid; or (b) assess a penalty against such Bidder in an amount not to exceed 5% of the bid amount and that such penalty will be paid to the contracting agency or deducted from any unpaid balance on the contract or purchase order.

By submission of this certificate, Bidder agrees to disclose any reasonably requested information to the Purchasing Division and authorizes the Department of Revenue to disclose to the Director of Purchasing appropriate information verifying that Bidder has paid the required business taxes, provided that such information does not contain the amounts of taxes paid nor any other information deemed by the Tax Commissioner to be confidential.

Under penalty of law for false swearing (*West Virginia Code*, §61-5-3), Bidder hereby certifies that this certificate is true and accurate in all respects; and that if a contract is issued to Bidder and if anything contained within this certificate changes during the term of the contract, Bidder will notify the Purchasing Division in writing immediately.

Bidder: STATE EQUIPMENT, INC.

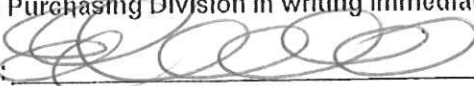
Signed: 

Date: 6-26-2012

Title: GENERAL MANAGER

*Check any combination of preference consideration(s) indicated above, which you are entitled to receive.

STATE OF WEST VIRGINIA
Purchasing Division

PURCHASING AFFIDAVIT

West Virginia Code §5A-3-10a states: No contract or renewal of any contract may be awarded by the state or any of its political subdivisions to any vendor or prospective vendor when the vendor or prospective vendor or a related party to the vendor or prospective vendor is a debtor and the debt owed is an amount greater than one thousand dollars in the aggregate.

DEFINITIONS:

"Debt" means any assessment, premium, penalty, fine, tax or other amount of money owed to the state or any of its political subdivisions because of a judgment, fine, permit violation, license assessment, defaulted workers' compensation premium, penalty or other assessment presently delinquent or due and required to be paid to the state or any of its political subdivisions, including any interest or additional penalties accrued thereon.

"Debtor" means any individual, corporation, partnership, association, limited liability company or any other form or business association owing a debt to the state or any of its political subdivisions. "Political subdivision" means any county commission; municipality; county board of education; any instrumentality established by a county or municipality; any separate corporation or instrumentality established by one or more counties or municipalities, as permitted by law; or any public body charged by law with the performance of a government function or whose jurisdiction is coextensive with one or more counties or municipalities. "Related party" means a party, whether an individual, corporation, partnership, association, limited liability company or any other form or business association or other entity whatsoever, related to any vendor by blood, marriage, ownership or contract through which the party has a relationship of ownership or other interest with the vendor so that the party will actually or by effect receive or control a portion of the benefit, profit or other consideration from performance of a vendor contract with the party receiving an amount that meets or exceed five percent of the total contract amount.

EXCEPTION: The prohibition of this section does not apply where a vendor has contested any tax administered pursuant to chapter eleven of this code, workers' compensation premium, permit fee or environmental fee or assessment and the matter has not become final or where the vendor has entered into a payment plan or agreement and the vendor is not in default of any of the provisions of such plan or agreement.

Under penalty of law for false swearing (*West Virginia Code* §61-5-3), it is hereby certified that the vendor affirms and acknowledges the information in this affidavit and is in compliance with the requirements as stated.

WITNESS THE FOLLOWING SIGNATURE

Vendor's Name: STATE EQUIPMENT, INC.

Authorized Signature:  Date: 6-26-2012

State of WEST VIRGINIA

County of Kanawha, to-wit:

Taken, subscribed, and sworn to before me this 26th day of June, 2012.

My Commission expires March 27, 2021.

AFFIX SEAL HERE

NOTARY PUBLIC 

