



State of West Virginia
 Department of Administration
 Purchasing Division
 2019 Washington Street East
 Post Office Box 50130
 Charleston, WV 25305-0130

Request for Quotation

RFQ NUMBER
 7012C003

PAGE
 1

ADDRESS CORRESPONDENCE TO ATTENTION OF:
 PAUL REYNOLDS
 304-558-0468

RFQ COPY

TYPE NAME/ADDRESS HERE

VENDOR

Communication Service, Inc.
 12403 MacCorkle Avenue
 Charleston, WV 25315

SHIP TO

DIVISION OF HIGHWAYS
 EQUIPMENT DIVISION
 VARIOUS LOCALES AS INDICATED
 BY ORDER

DATE PRINTED 08/19/2011	TERMS OF SALE NET 30	SHIP VIA Bestway	F.O.B. Destination	FREIGHT TERMS
----------------------------	-------------------------	---------------------	-----------------------	---------------

BID OPENING DATE: 09/07/2011 BID OPENING TIME 01:30PM

LINE	QUANTITY	UOP	CAT NO.	ITEM NUMBER	UNIT PRICE	AMOUNT
0001		EA		055-57		
<p>LED BAR LIGHTS</p> <p>REQUEST FOR QUOTATION OPEN END CONTRACT</p> <p>THE WEST VIRGINIA STATE PURCHASING DIVISION FOR THE AGENCY, THE WEST VIRGINIA DIVISION OF HIGHWAYS IS SOLICITING BIDS FOR AN OPEN END CONTRACT TO PROVIDE LED BAR LIGHTS PER THE ATTACHED SPECIFICATIONS.</p> <p>TECHNICAL QUESTIONS CONCERNING THIS SOLICITATION MUST BE SUBMITTED IN WRITING TO PAUL REYNOLDS IN THE WEST VIRGINIA STATE PURCHASING DIVISION VIA MAIL AT THE ADDRESS SHOWN IN THE BODY OF THIS RFQ, VIA FAX AT 304-558-4115, OR VIA EMAIL AT PAUL.REYNOLDS@WV.GOV. DEADLINE FOR ALL TECHNICAL QUESTIONS IS 09/02/2011 AT THE CLOSE OF BUSINESS. ANY TECHNICAL QUESTIONS RECEIVED WILL BE ANSWERED BY FORMAL ADDENDUM TO BE ISSUED BY THE PURCHASING DIVISION AFTER THE DEADLINE HAS LAPSED.</p> <p>EXHIBIT 3</p> <p>LIFE OF CONTRACT: THIS CONTRACT BECOMES EFFECTIVE UPON AWARD AND EXTENDS FOR A PERIOD OF ONE (1) YEAR OR UNTIL SUCH "REASONABLE TIME" THEREAFTER AS IS NECESSARY TO OBTAIN A NEW CONTRACT OR RENEW THE ORIGINAL CONTRACT. THE "REASONABLE TIME" PERIOD SHALL NOT EXCEED TWELVE (12) MONTHS. DURING THIS "REASONABLE</p>						

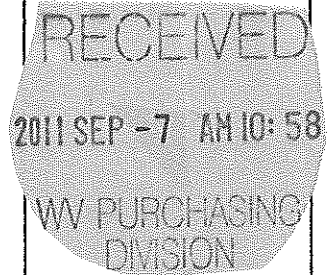

SEE REVERSE SIDE FOR TERMS AND CONDITIONS			
SIGNATURE <i>Anna Martin</i>	TELEPHONE 304-949-4160	DATE 9-6-2011	
TITLE Office Manager	FEIN 55-0547641	ADDRESS CHANGES TO BE NOTED ABOVE	

WHEN RESPONDING TO RFQ, INSERT NAME AND ADDRESS IN SPACE ABOVE LABELED 'VENDOR'



State of West Virginia
 Department of Administration
 Purchasing Division
 2019 Washington Street East
 Post Office Box 50130
 Charleston, WV 25305-0130

Request for Quotation

RFQ NUMBER
7012C003

PAGE
2

ADDRESS CORRESPONDENCE TO ATTENTION OF
PAUL REYNOLDS 304-558-0468

*709063202 304-425-7511
 WORLDWIDE EQUIPMENT INC
 PO BOX 1433
 PRINCETON WV 24740

VENDOR

DIVISION OF HIGHWAYS
 EQUIPMENT DIVISION
 VARIOUS LOCALES AS INDICATED
 BY ORDER

SHIP TO

DATE PRINTED	TERMS OF SALE	SHIP VIA	F.O.B.	FREIGHT TERMS
08/19/2011				

BID OPENING DATE: 09/07/2011 BID OPENING TIME 01:30PM

LINE	QUANTITY	UOP	CAT NO	ITEM NUMBER	UNIT PRICE	AMOUNT
<p>TIME" THE VENDOR MAY TERMINATE THIS CONTRACT FOR ANY REASON UPON GIVING THE DIRECTOR OF PURCHASING 30 DAYS WRITTEN NOTICE.</p> <p>UNLESS SPECIFIC PROVISIONS ARE STIPULATED ELSEWHERE IN THIS CONTRACT DOCUMENT, THE TERMS, CONDITIONS AND PRICING SET HEREIN ARE FIRM FOR THE LIFE OF THE CONTRACT.</p> <p>RENEWAL: THIS CONTRACT MAY BE RENEWED UPON THE MUTUAL WRITTEN CONSENT OF THE SPENDING UNIT AND VENDOR, SUBMITTED TO THE DIRECTOR OF PURCHASING THIRTY (30) DAYS PRIOR TO THE EXPIRATION DATE. SUCH RENEWAL SHALL BE IN ACCORDANCE WITH THE TERMS AND CONDITIONS OF THE ORIGINAL CONTRACT AND SHALL BE LIMITED TO TWO (2) ONE (1) YEAR PERIODS.</p> <p>CANCELLATION: THE DIRECTOR OF PURCHASING RESERVES THE RIGHT TO CANCEL THIS CONTRACT IMMEDIATELY UPON WRITTEN NOTICE TO THE VENDOR IF THE COMMODITIES AND/OR SERVICES SUPPLIED ARE OF AN INFERIOR QUALITY OR DO NOT CONFORM TO THE SPECIFICATIONS OF THE BID AND CONTRACT HEREIN.</p> <p>OPEN MARKET CLAUSE: THE DIRECTOR OF PURCHASING MAY AUTHORIZE A SPENDING UNIT TO PURCHASE ON THE OPEN MARKET, WITHOUT THE FILING OF A REQUISITION OR COST ESTIMATE, ITEMS SPECIFIED ON THIS CONTRACT FOR IMMEDIATE DELIVERY IN EMERGENCIES DUE TO UNFORESEEN CAUSES (INCLUDING BUT NOT LIMITED TO DELAYS IN TRANSPORTATION OR AN UNANTICIPATED INCREASE IN THE VOLUME OF WORK.)</p> <p>QUANTITIES: QUANTITIES LISTED IN THE REQUISITION ARE APPROXIMATIONS ONLY, BASED ON ESTIMATES SUPPLIED BY THE STATE SPENDING UNIT. IT IS UNDERSTOOD AND AGREED THAT THE CONTRACT SHALL COVER THE QUANTITIES ACTUALLY</p>						

SIGNATURE <i>[Signature]</i>			SEE REVERSE SIDE FOR TERMS AND CONDITIONS		TELEPHONE 304-776-4091	DATE Sept 6 2011
TITLE President	FIRM 550520004	ADDRESS CHANGES TO BE NOTED ABOVE				

WHEN RESPONDING TO RFQ, INSERT NAME AND ADDRESS IN SPACE ABOVE LABELED 'VENDOR'



State of West Virginia
 Department of Administration
 Purchasing Division
 2019 Washington Street East
 Post Office Box 50130
 Charleston, WV 25305-0130

Request for Quotation

RFQ NUMBER
 7012C003

PAGE
 4

ADDRESS CORRESPONDENCE TO ATTENTION OF
 PAUL REYNOLDS
 304-558-0468

*709063202 304-425-7511
 WORLDWIDE EQUIPMENT INC
 PO BOX 1433
 PRINCETON WV 24740

DIVISION OF HIGHWAYS
 EQUIPMENT DIVISION
 VARIOUS LOCALES AS INDICATED
 BY ORDER

DATE PRINTED	TERMS OF SALE	SHIP VIA	FOB	FREIGHT TERMS
08/19/2011				

BID OPENING DATE: 09/07/2011 BID OPENING TIME 01:30PM

LINE	QUANTITY	UOP	QTY NO	ITEM NUMBER	UNIT PRICE	AMOUNT
<p>SHALL NOT PREJUDICE THE AWARD OF THIS CONTRACT IN ANY MANNER.</p> <p>REV. 3/88</p> <p>PURCHASING CARD ACCEPTANCE: THE STATE OF WEST VIRGINIA CURRENTLY UTILIZES A VISA PURCHASING CARD PROGRAM WHICH IS ISSUED THROUGH A BANK. THE SUCCESSFUL VENDOR MUST ACCEPT THE STATE OF WEST VIRGINIA VISA PURCHASING CARD FOR PAYMENT OF ALL ORDERS PLACED BY ANY STATE AGENCY AS A CONDITION OF AWARD.</p> <p>EXHIBIT 10</p> <p>REQUISITION NO.:</p> <p>ADDENDUM ACKNOWLEDGEMENT</p> <p>I HEREBY ACKNOWLEDGE RECEIPT OF THE FOLLOWING CHECKED ADDENDUM(S) AND HAVE MADE THE NECESSARY REVISIONS TO MY PROPOSAL, PLANS AND/OR SPECIFICATION, ETC.</p> <p>ADDENDUM NO. S:</p> <p>NO. 1</p> <p>NO. 2</p> <p>NO. 3</p> <p>NO. 4</p> <p>NO. 5</p> <p>I UNDERSTAND THAT FAILURE TO CONFIRM THE RECEIPT OF</p>						

SEE REVERSE SIDE FOR TERMS AND CONDITIONS

SIGNATURE: *Thomas E. Fink* TELEPHONE: 304-776-4091 DATE: Sept 6 2011

TITLE: President FEIN: 580520084 ADDRESS CHANGES TO BE NOTED ABOVE

WHEN RESPONDING TO RFQ, INSERT NAME AND ADDRESS IN SPACE ABOVE LABELED 'VENDOR'



State of West Virginia
 Department of Administration
 Purchasing Division
 2019 Washington Street East
 Post Office Box 50130
 Charleston, WV 25305-0130

Request for Quotation

RFQ NUMBER
 7012C003

PAGE
 6

ADDRESS CORRESPONDENCE TO ATTENTION OF
 PAUL REYNOLDS
 304-558-0468

PROPERTY

*709063202 304-425-7511
 WORLDWIDE EQUIPMENT INC
 PO BOX 1433
 PRINCETON WV 24740

PROPERTY

DIVISION OF HIGHWAYS
 EQUIPMENT DIVISION
 VARIOUS LOCALES AS INDICATED
 BY ORDER

DATE PRINTED	TERMS OF SALE	SHIP VIA	F.O.B.	FREIGHT TERMS
08/19/2011				

BID OPENING DATE: 09/07/2011 BID OPENING TIME 01:30PM

LINE	QUANTITY	UOP	QTY NO	ITEM NUMBER	UNIT PRICE	AMOUNT
THE BID SHOULD CONTAIN THIS INFORMATION ON THE FACE OF THE ENVELOPE OR THE BID MAY NOT BE CONSIDERED: SEALED BID BUYER: PAUL REYNOLDS FILE 33 RFQ. NO.: 7012C003 BID OPENING DATE: 09/07/2011 BID OPENING TIME: 01:30 P.M. PLEASE PROVIDE A FAX NUMBER IN CASE IT IS NECESSARY TO CONTACT YOU REGARDING YOUR BID: ----- 304-776-7092 ----- CONTACT PERSON (PLEASE PRINT CLEARLY): ----- Tim Ford ----- ***** THIS IS THE END OF RFQ 7012C003 ***** TOTAL: <u>889⁰⁰</u>						

SEE REVERSE SIDE FOR TERMS AND CONDITIONS

SIGNATURE: *[Signature]* TELEPHONE: 304-776-4091 DATE: Sept 6 2011

TITLE: President FEIN: 550520004 ADDRESS CHANGES TO BE NOTED ABOVE

WHEN RESPONDING TO RFQ, INSERT NAME AND ADDRESS IN SPACE ABOVE LABELED 'VENDOR'

**WHELEN SUPER-LED® LIGHT BAR
OR EQUAL CONTRACT
7012C003**

I. PURPOSE AND SCOPE:

The purpose of this Request for Quotation No. 7012C003 and resulting contract ("Contract") between West Virginia Department of Transportation, Division of Highways ("DOH") and the winning vendor ("Vendor") is to provide LED Light bars as required by the WV DOH.

II. GENERAL REQUIREMENTS:

1. Exhibit A provides a list of part numbers that must be provided. Exhibit A must be completed for evaluation purposes. Exhibit A is Only a partial list of parts that may be required by DOH.
2. Upon request vendor will provide proof of all mandatory requirements.

III. PRICING:

1. This Contract shall be awarded based on a single price. Exhibit A.
2. This Contract shall be limited to the single item listed.
3. Vendor shall submit the Bid Evaluation Price Chart, attached hereto and incorporated herein by reference as Exhibit A, to allow bid evaluation. The Vendor should insert the manufacturer's discounted unit price in the space provided. The Vendor should then multiply the estimated quantity by the discounted unit price to obtain the total discounted price to agency.

IV. ORDERING INFORMATION:

1. Parts orders against this contract may be placed by the DOH Equipment Division and any other DOH District locations. A list of the current DOH locations is attached as Exhibit B. Orders may be placed by telephone and/or facsimile.

V. DELIVERY REQUIREMENTS:

1. Vendor must ship all items to DOH under this Contract FOB DESTINATION.
2. DOH will pay freight charges only if DOH request 24 hour delivery.
3. Vendor shall deliver the goods to the DOH locations as requested by DOH. A list of the DOH locations is attached hereto and incorporated herein by reference as Exhibit B. DOH reserves the right to change DOH locations or request delivery to another location at no additional charge after notifying Vendor of the new location and requesting delivery thereto.
4. Delivery is an integral part of this contract and Vendor's failing to comply with the delivery terms will be grounds for submission of a WV-82 Form officially notifying the Purchasing Division and the Vendor of unsatisfactory performance.

5. Vendor's failure to obtain prior approval from DOH for changes to delivery schedules or to deliver the goods in a timely manner may be grounds for cancellation of this Contract.
6. Vendor must ship orders promptly upon receipt and delivery must be made within three (3) business days of receipt of an order. Vendor shall not require that a certain order quantity be met prior to shipping DOH orders.
7. If Vendor cannot deliver the goods ordered within three working days then Vendor shall immediately notify DOH of the anticipated delivery date. If DOH finds the delivery date unacceptable then DOH may purchase the needed items on the open market with approval from the DOH Equipment Division Director, the DOH District Equipment Supervisor, or a designee of either. Any open market purchase made hereunder shall be in accordance with the laws, rules, and regulations, of the Department of Administration, Purchasing Division.
8. DOH is not responsible for any restocking charge on items that are returned to Vendor as faulty or for failure to conform to the required specifications. In all other instances, DOH will only pay restocking fees if DOH, in its sole discretion, believes that such a charge is warranted.
9. All deliveries must be conspicuously marked with the DOH Purchase Order Number. Any goods delivered without this information may be returned to Vendor at Vendor's expense.

VI. PAYMENT:

1. The State of West Virginia currently utilizes a Visa purchasing card program. The State of West Virginia Visa purchasing card is the preferred method of payment, but other methods of payments may be utilized from time to time at the sole description of DOH. The successful vendor must accept the State of West Virginia Visa purchasing card for payment of all orders placed under this Contract.
2. Vendor must supply a credit receipt, sales receipt, or cash register receipt to DOH after Payment has been made.
3. Payment shall be made after DOH has received and accepted the goods being delivered. Vendor shall not charge the State of West Virginia Visa purchasing card until goods are received and accepted by DOH.

VII. MISCELLANEOUS:

1. All warranty claims that require field service shall be performed by Vendor at no cost to DOH.
2. Vendor shall furnish any technical engineering service which might be needed in the proper installation of these parts at no extra cost to the DOH.
3. Vendor shall comply with all federal, state, and local laws, rules and regulations.
4. Concurrently with each shipment, Vendor shall forward a proper and current Material Safety Data Sheet ("MSDS") to the DOH Equipment Division in Buckhannon, WV. Vendor shall also furnish the State of West Virginia and/or any of its other agencies with Additional MSDS as requested.

5. Vendor shall assume all liability and costs for failures and downtime that result from DOH use of Vendor's products.
6. This Contract will be awarded complete and not split.
7. Vendor must guarantee that it will maintain adequate stock to supply the needs of DOH at all times.

PLEASE SEE ATTACHED SPECIFICATIONS

SPECIFICATIONS FOR A WHELEN SUPER-LED® LIGHTBAR OR EQUAL

The emergency vehicle lightbar must be a Whelen Justice Series Lightbar, or equal as specified below. The product being bid must meet all current "S.A.E." requirements for this type and use of warning device, and be certified by an AMECA-accredited testing lab to meeting these requirements in the appropriate specified safety colors.

1.00 BASIC STRUCTURAL DESIGN OF LIGHTBAR:	YES	NO
1.01 The lightbar shall be designed for advanced aerodynamic efficiency.	<u>Y</u>	<u> </u>
1.02 The lightbar must be 56.25 inches (± 2 inches) in length with a maximum height of 2.25 inches and a maximum depth of 12 inches.	<u>Y</u>	<u> </u>
1.03 The main structural material shall be of heavy gauge extruded aluminum and shall be designed with dual vertical supports to allow superior structural strength (no sagging). The black polycarbonate base shall mount over the extruded aluminum support. The dome covers must screw into the polycarbonate base. The use of clips is unacceptable because they fail with time.	<u>Y</u>	<u> </u>
 2.00 CONSTRUCTION OF OUTER DOMES:		
2.01 The outer domes shall be constructed of polycarbonate. There shall be four dome sections on the 56 inch lightbar, and each section must be completely sealed to provide a weather-tight seal. The domes shall mount to the polycarbonate base. Light bars that utilize clips or clamps are not acceptable since they may corrode or loose tension over time and fly off.	<u>Y</u>	<u> </u>
2.02 Each dome must be easily replaceable without removing the lightbar from the roof of the vehicle.	<u>Y</u>	<u> </u>
2.03 The light through domes shall not be blocked and shall be of equal intensity to the viewer from the front, rear, or sides.	<u>Y</u>	<u> </u>
2.04 The domes shall be clear in color with optional colored outer domes available.	<u>Y</u>	<u> </u>

		YES	NO
2.05	The domes must have a sealant "hard coating" applied during production to maximize the durability of the lens.	<u>Y</u>	<u> </u>

3.00 INTERNAL COMPONENT SYSTEMS:

3.01	The lightbar shall contain one (1) control module I/O board which shall contain all the electronics required to operate all internal lighthoods. This single module is required for ease of servicing the lightbar. Lightbars with multiple I/O boards or those that require replacement of LED board assemblies are unacceptable. All internal components such as lamp modules, and I/O modules shall be modular in design for ease of replacement without removing the lightbar from the roof of the vehicle. The I/O module shall be 100% solid state with built-in reverse-polarity protection and output-short protection. They shall operate from 10-16 VDC with no degradation in Flash rate, and shall operate through a temperature range of -30 degrees Celsius to 60 degrees Celsius.	<u>Y</u>	<u> </u>
------	--	----------	---------------

3.02	All internal lighthoods must be Phosphor converted Amber LEDs (Generation 3.5 Super-LEDs) which provide maximum intensity and long, stable life. There must be a multiple of LED lighthoods to choose from.	<u>Y</u>	<u> </u>
------	---	----------	---------------

3.03	The lightbar's primary warning shall have a maximum of four (4) linear LED modules [1 in each corner] with only the four corner modules. Lightbars that utilize more than four modules to meet SAE Class I requirements are not acceptable. A copy of the Testing Lab or AMECA Certificate confirming that the lightbar conforms to SAE Class 1 requirements is required with this bid. Failure to submit this documentation will disqualify the bidder. Lightbars that do not use Linear LEDs as primary warning are not acceptable. The lightbar shall have linear LED modules in the four corners. Each Linear-LED corner module shall contain Super-LEDs mounted in the parabolic center of a single "removable" highly mirrored reflector for maximum light output. Corner light modules that utilize multiple reflectors or mirrors are not acceptable since they do not provide a true, even light spread. The Linear-LEDs shall be mounted in a straight line and have a single diffuser panel collimator mounted in front of them for maximum light output. The removable reflector must contain the LEDs and		
------	--	--	--

	YES	NO
allow for removal of each individual lighthead for ease of changing the light configuration. Lightbars that require the removal of large multi-LED panels to replace / reconfigure a lighthead are not acceptable. The lightbar must contain a minimum of eight (8) CON3 Super-LED panels or equal (4 Front Center / 4 Rear Center). Each CON3 module must contain a maximum of three (3) Super-LEDs and must be supplied with a removable optical filter that disperses the light. The LED panel must be mounted within the lightbar. Systems in which the LED panel/lens assembly makes up the outside configuration of the lightbar are not acceptable.	Y	_____
3.04 The lightbar must contain:		
To the Front: Two (2) Amber Linear6 corners or equal Four (4) Amber CON3 or equal	Y	_____
To the Rear: Two (2) Amber Linear6 corners or equal Four (4) Amber CON3 or equal	Y	_____
4.00 EXTERNAL CABLE:		
4.01 There shall be two (2) cables exiting the lightbar on the passenger side. Each cable shall be heavy duty water resistant: (1) 4 conductor, 14 gauge power and ground cable (one pair controls front operation and the second set controls rear operation); and one 3 conductor 22 gauge cable for Scan-Lock and pattern override feature. The external cable shall be a minimum of 17 feet.	Y	_____
5.00 MOUNTING KIT:		
5.01 The mounting kit shall be permanent mount.	Y	_____
6.00 WARRANTY		
6.01 The system shall be warranted by the manufacturer to the user directly to be free from defects of material or workmanship for a period of 24 months from date of purchase (no warranty is offered on optical plastic parts). LED's shall be warranted for a period of five years. Written proof of this warranty by the manufacturer must		

- | | YES | NO |
|---|----------|---------------|
| Be furnished by the bidder and attached to the bid. | <u>Y</u> | <u> </u> |
| 6.02 The manufacturer shall provide a twenty-four (24) month warranty on both parts and factory labor. This shall include forty-eight (48) hour factory turnaround repair service. Out-of-warranty product shall receive the same quality service and be repaired at a flat service rate of \$75.00, which includes shipping/handling fee for each unit returned (excluding new or necessary hardware such as lenses, flash tubes, etc.). | <u>Y</u> | <u> </u> |
| 6.03 The successful bidder must be the manufacturer or an authorized stocking distributor for Lightbar being bid and have in stock sufficient quantities of service parts to maintain the needs of the department within forty-eight (48) hours after call. | <u>Y</u> | <u> </u> |

Quality Reference: Whelen Justice Bar JE2AMB, (8) CON3s. Or Equal

EXHIBIT B: DIVISION OF HIGHWAYS LOCATIONS**Equipment Division**

WV Division of Highways
 PO Box 610
 Buckhannon, WV 26201
 ATTENTION: Kevin Riley (FOUR COPIES)

WVDOT/Division of Highways
 D-1
 1340 Smith St.
 Charleston, WV 25301
 Attn: Bob Heckert

WVDOT/Division of Highways
 D-2
 Po. Box 880
 Huntington, WV 25712
 Attn: Barbara King

WVDOT/Division of Highways
 D-3
 626 Depot St.
 Parkersburg, WV 26101
 Attn: Beverly Myers

WVDOT/Division of Highways
 D-4
 P.O. BOX 2570
 Clarksburg, WV 26301
 Attn: John Bartlett

WVDOT/Division of Highways
 D-5
 PO BOX 99
 BURLINGTON, WV 26710
 Attn: Laranda Baldwin

WVDOT/Division of Highways
 D-6
 1 DOT Drive.
 Moundsville, WV 26041-2353
 Attn: Carol Ryan

WVDOT/Division Highways
 D-7
 Drawer 1228
 Weston, WV 26452
 Attn: Melissa Jordan

WVDOT/Division of Highways
 D-8
 PO Box 1516
 Elkins, WV 26241
 Attn: Debbie Barnett

WVDOT/Division of Highways
 D-9
 103 ½ Church Street
 Lewisburg, WV 24901
 Attn: Sherry Bostic

WVDOT/Division of Highways
 D-10
 270 Hardwood Lane
 Princeton, WV 24740
 Attn: Tommy Camden

RFQ No: 7012C003

STATE OF WEST VIRGINIA
Purchasing Division

PURCHASING AFFIDAVIT

West Virginia Code §5A-3-10a states: No contract or renewal of any contract may be awarded by the state or any of its political subdivisions to any vendor or prospective vendor when the vendor or prospective vendor or a related party to the vendor or prospective vendor is a debtor and the debt owned is an amount greater than one thousand dollars in the aggregate

DEFINITIONS:

"Debt" means any assessment, premium, penalty, fine, tax or other amount of money owed to the state or any of its political subdivisions because of a judgment, fine, permit violation, license assessment, defaulted workers' compensation premium, penalty or other assessment presently delinquent or due and required to be paid to the state or any of its political subdivisions, including any interest or additional penalties accrued thereon.

"Debtor" means any individual, corporation, partnership, association, Limited Liability Company or any other form or business association owing a debt to the state or any of its political subdivisions. "Political subdivision" means any county commission; municipality; county board of education; any instrumentality established by a county or municipality; any separate corporation or instrumentality established by one or more counties or municipalities, as permitted by law; or any public body charged by law with the performance of a government function or whose jurisdiction is coextensive with one or more counties or municipalities. "Related party" means a party, whether an individual, corporation, partnership, association, limited liability company or any other form or business association or other entity whatsoever, related to any vendor by blood, marriage, ownership or contract through which the party has a relationship of ownership or other interest with the vendor so that the party will actually or by effect receive or control a portion of the benefit, profit or other consideration from performance of a vendor contract with the party receiving an amount that meets or exceeds five percent of the total contract amount.

EXCEPTION: The prohibition of this section does not apply where a vendor has contested any tax administered pursuant to chapter eleven of this code, workers' compensation premium, permit fee or environmental fee or assessment and the matter has not become final or where the vendor has entered into a payment plan or agreement and the vendor is not in default of any of the provisions of such plan or agreement.

Under penalty of law for false swearing (*West Virginia Code §61-5-3*), it is hereby certified that the vendor affirms and acknowledges the information in this affidavit and is in compliance with the requirements as stated.

WITNESS THE FOLLOWING SIGNATURE

Vendor's Name: Electronic Communications of WV Inc

Authorized Signature: [Signature] Date: Sept 6 2011

State of West Virginia

County of Kanawha, to-wit:

Taken, subscribed, and sworn to before me this 6 day of September, 2011.

My Commission expires May 10, 2020

AFFIX SEAL HERE

NOTARY PUBLIC

[Signature]

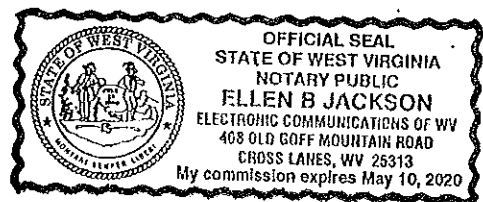

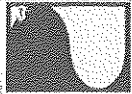

SALES QUOTATION

ELECTRONIC COMMUNICATIONS OF WV INC

TOTAL COMMUNICATIONS SALES and SERVICE

September 6, 2011

408 Old Goff Mountain Road
Cross Lanes WV 25313
304-776-4091 phone, 304-776-7092 fax
Toll Free in WV 800-570-4091

QUOTED TO:

West Virginia Department Of Highways
Equipment Division
Various Locales

SHIPPED TO:

SALESPERSON	QUOTE #	SHIPPING METHOD	SHIPPING TERMS	DELIVERY DATE	PAYMENT TERMS
Tim Ford	10244	Standard	FOB	15 days Aro	Net 30

ITEM #	QTY	DESCRIPTION	CONTRACT PRICE	CONTRACT EXTENDED
1	1	Whelen Justice Model #JE2AMB Light Bar Complete W/4 Extended Corner LED Four(4) Front Facing Con 3 LED Modules and Four (4) Rear Facing Con 3 LED Modules	889.00	889.00
2	1	Whelen MKEZ 38 Hook Mount for Ford F-250, 350, 550	0.00	
			SUBTOTAL	\$889.00
			WV Sales Tax	0.00
			TOTAL	\$889.00

WHELEN[®]
ENGINEERING COMPANY, INC.
Technical Research Testing Laboratory

Rt. 145, Chester, CT 06412
Phone : 860-526-9504
Fax : 860-526-4078

Certificate of Compliance

This notice verifies that the item below has been tested by an AMECA accredited laboratory and has been found to be in compliance with the jurisdictional standard(s) listed below where applicable.

Justice Bar (6 LED Corners)
Amber, Blue, Red

Meets photometry of jurisdictional compliance standard(s) identical to:

- CA TITLE 13 BLUE
- CA TITLE 13 RED
- CA TITLE 13 YELLOW

Test Equipment : Hoffman Automated Goniophotometer System

The above test equipment meets the guidelines of J1330, and has been calibrated by Hoffman Engineering Corp. with accuracies traceable to the National Institute of Standards and Technology.

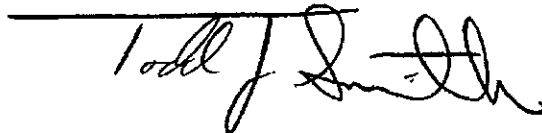

Photometric Laboratory Supervisor



AMECA
Accredited
Laboratory

WHELEN®

*USER DIRECT WARRANTY (FOR AUTOMOTIVE PRODUCTS ONLY)

Whelen Engineering Company, Inc. warrants products of its manufacture against defects in material and workmanship. This is provided that the product has been installed and operated in accordance with the manufacturer's recommendations. During the warranty period (see below) the Factory Repair Center or an Authorized Whelen Repair Center† will repair or replace (at its option) any parts or electronic assemblies of the unit which disclose a defect in material or workmanship. The Repair Center will return the repaired unit, transportation cost prepaid.

The above warranty is between the first purchaser (ultimate user) only and Whelen Engineering Company, Inc. (manufacturer). No prior authorization is required for returning Whelen products for warranty consideration. Each Whelen product sold is covered only by the official warranty in effect at time of purchase.

This warranty is not applicable to any Whelen product that has failed due to abuse, misuse, improper installation, excessive voltages, or alterations to the product that affects, in the manufacturer's judgment, intended use and service. Whelen will not be held liable for any incidental or consequential damages, and assumes no responsibility or liability for expenses incurred in the removal and/or re-installation of products requiring service and/or repair; nor the packaging, handling, and shipping to the Factory Repair Center or Authorized Whelen Repair Center†; nor for the handling of products returned from the repair center after service or repair.

There are no other warranties, expressed or implied, including, but not limited to, any implied merchantability or fitness for a particular use. Whelen Engineering Company, Inc. reserves the right to modify this warranty statement at any time; or discontinue, modify, or upgrade any products of its manufacture with design improvements without prior notice.

All power plugs/cigar plugs, incandescent and halogen bulbs, polycarbonate/plastic materials, radar products, aviation equipment, industrial products and high power voice/siren systems are not covered by this warranty (see applicable warranty statement). This warranty will be void when using or substituting other than all-genuine Whelen system components, such as remote head assemblies, xenon flash tubes, shielded cables, strobe power supplies, siren amplifiers and siren speakers.

This warranty gives you specific rights, and you may also have other rights which vary from state to state.

WHELEN ENGINEERING COMPANY ELECTRO-MECHANICAL AND STROBE PRODUCTS

STANDARD / 2-YEAR WARRANTY

Whelen products are covered by a direct warranty for up to a maximum two years from date of purchase (not to exceed three years from date of manufacture), with proof of purchase. In accordance with the policy statement described herein, the unit may be returned directly to the factory or to an Authorized Whelen Repair Center† for warranty consideration. Whelen 100 watt siren speakers are covered by a 2-year warranty from the date of manufacture. Heavy-Duty motor assemblies (so marked) are covered by a direct warranty for up to three years from date of manufacture. For warranty consideration, both the siren speakers and motor assemblies are subject to the conditions and steps described herein.

HDP® / 5-YEAR WARRANTY

Whelen Automotive Non-Lightbar Strobe Power Supplies, LED Ballasts and LED Products bearing the official HDP label and manufactured to HDP standards, are covered by a direct warranty for up to five years from date of manufacture. In accordance with the policy statement described herein, the unit may be returned directly to the factory or to an Authorized Whelen Repair Center† for warranty consideration.



12 MONTH WARRANTY — BACK-UP ALARMS

Whelen Back-Up Alarms are covered by a 12 month warranty. Both are subject to the conditions and steps described herein.

*10 YEAR LIMITED WARRANTY — LIGHTBAR POWER SUPPLY

All repairable warranty and non-warranty Edge® style lightbar strobe power supplies will be replaced with a compatible new power supply. If out of initial warranty period but less than 7 years old, the charge will be a flat fee of \$130.00; if between 7 & 10 years old, the charge will be a flat fee of \$145.00 (warranty for standard power supply is 2 years and Heavy-Duty Professional (HDP®) power supply is 5 years). This is subject to the conditions and steps described herein.

12 AND 24 MONTH DIRECT WARRANTY — XENON FLASH TUBES

(Except Flash Tubes from 1000/1500/2000/3000 & VP Series which are covered by a 6 month warranty)

If the xenon flash tube component of a "Whelen" brand (not from 1000/1500/2000/3000 or VP Series) product is returned to Whelen within 12 months of the date which is affixed to the flash tube, Whelen will replace that flash tube free of charge ONE TIME ONLY, subject to the conditions and steps herein. Whelen "Gold Medallion" flash tubes including all linear flash tube assemblies, carry a 24 month warranty. Whelen will pay ground transportation from Whelen's factory or Authorized Whelen Repair Center† to the customer via UPS where available (in the Continental U.S.).

12 MONTH EXTENDED WARRANTY — WHELEN REPAIRED STROBE POWER SUPPLIES

Whelen offers to repair or replace, free of charge, any part of its strobe light power supplies that have been repaired by Whelen within 12 months and are less than 5 years old, subject to the conditions and steps herein. Whelen will pay ground transportation from Whelen's factory or Authorized Whelen Repair Center† to the customer via UPS where available (in the Continental U.S.).

*WHELEN ENGINEERING COMPANY OUT-OF-WARRANTY FACTORY REPAIR PROGRAM:

If found to be repairable, the Whelen Factory Repair Center (only) will repair Non-Lightbar Electronic Strobe Power Supplies for \$80 each. This does not include replacement of any other electro-mechanical parts including flash tubes, polycarbonate domes, motors, or hardware items.

Follow the "Steps To Be Taken For Return" noted below, and include a check or money order for \$80 for each unit returned. For Whelen products older than 10 years, repair charges will be determined upon examination only (minimum charge is \$145). Contact factory service center for further details.

STEPS TO BE TAKEN FOR WARRANTY RETURN:

- 1) Whelen products are to be returned freight prepaid to the: Whelen Factory Repair Center Building B, 51 Winthrop Road, Chester, CT 06412-0684; or an Authorized Whelen Repair Center†. Do not ship by bus.
- 2) A copy of the sales receipt must be returned with the defective unit to qualify for warranty coverage from date of purchase.
- 3) Include a short statement explaining the problem.
- 4) Include your name, address, and day-time telephone number.
- 5) Whelen and its Authorized Repair Centers will, via UPS, ship back the repaired unit freight prepaid, usually within a few days after its receipt.

WHELEN®

ENGINEERING COMPANY, INC.

51 Winthrop Road
Chester, CT 06412-0684
Phone: (860) 526-9504
Fax: (860) 526-4078
www.whelen.com

— EFFECTIVE 7/1/10, REPLACES ALL PREVIOUSLY PUBLISHED SERVICE POLICIES —

† The only AUTHORIZED WHELEN REPAIR CENTER(S) are predetermined by the Whelen Factory via official listing obtained from Whelen Engineering Company, Chester, CT.

*New/Revised

10250S-070-110

© 2010 Whelen.

WHELEN[®]

JUSTICE[®]

Super-LED[®] SERIES
LIGHTBARS



*Wheelen products
are proudly
manufactured
in the U.S.A.*



Form# JUST1009

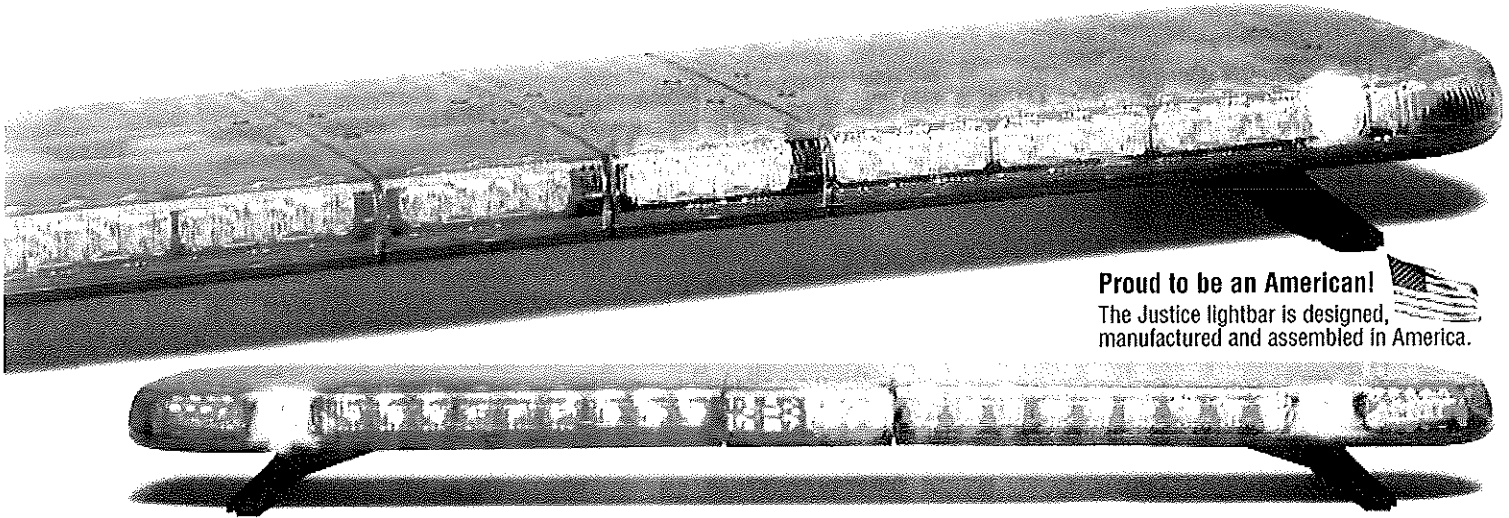

Proud to be an American!
The Justice lightbar is designed, manufactured and assembled in America.

NFPA Justice® Super-LED® Series, ZONE "A" UPPER

Same features as Justice Series but NFPA 1901 compliant. Contact us for our "NFPA 1901 Specification Lighting Packages" booklet. This booklet details complete packages and zone packages meeting NFPA 1901 requirements. Each lighting package includes a "Certificate of Compliance with NFPA 1901". Contact the factory for more information.

JE2NFPA 56" Four red corner Linear-LEDs, six front CON3s (4 red & 2 white)

JEONFPA 62" Four red corner Linear-LEDs, six front CON3s (4 red & 2 white)

Mini Justice Series, This is a compact, 22" version of the popular Justice lightbar has 4 corner Linear6™ Super-LEDs. Ideal for applications where full-size lightbars just won't work!

Four corner modules standard. Options include: four CON3™ Super-LED modules with optical spreaders, LTR3™ Super-LED modules and LR11 take-down/alley lights.

Magnetic and magnetic/suction mount has ten-foot cord, cigar plug with On/Off switch and LED "On" indicator plus Scan-Lock™ flash pattern switch.

Ninety-five Scan-Lock flash patterns.

Low profile design, only 2-1/4" high by 12" wide and 22" long.

Permanent mount models include 15' cable.

Weight: 20 lbs.

MINI JUSTICE JY Series

MJY****P 22" Permanent mount

MJY****M 22" Magnetic mount

MJY****V 22" Magnetic/suction mount

The use of any magnetic or magnetic/suction mounted warning beacon on the outside of a moving vehicle is not recommended and is at the sole risk of the user.

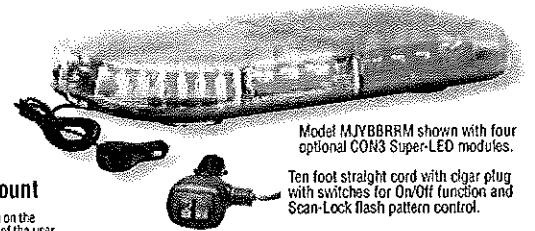
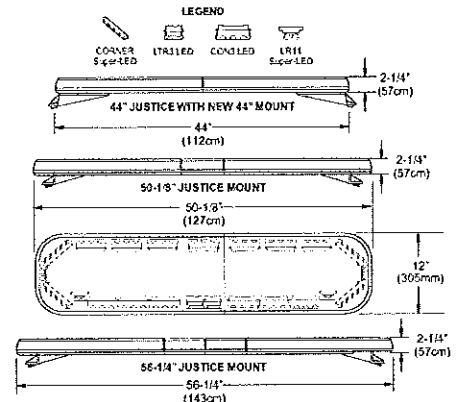

JUSTICE SERIES SPECIFICATIONS										
WeCan® Models	Competitor™ Models	NFPA	Mini Justice	Voltage	Amp Draw (base model)	Number & Type of Corner Modules	Super-LEDs per Corner Module	Maximum Number of Additional Modules	Mounts	H x D x L Dimensions In inches and (mm) Note: 4" (101) H with feet
JV4 / JY4	-	-	-	12.8	3.2 @13.6	4 Linear-LED®	9 on JV Series	18 (24 with split TA)	Requires Optional Mounting Kits	2-1/4 (57) x 12 (305) x 44 (112cm)
JV8 / JY8	-	-	-				6 on JY Series	22 (28 with split TA)		2-1/4 (57) x 12 (305) x 50-1/8 (127cm)
JV2 / JY2	-	-	-				9 on JC Series	18 (24 with split TA)		2-1/4 (57) x 12 (305) x 56-1/4 (143cm)
-	JC4 / JE4	-	-				6 on JE Series	22 (28 with split TA)		2-1/4 (57) x 12 (305) x 44 (112cm)
-	JC8 / JE8	-	-				9 on corners / 3 on inboards (6 each standard)	10		2-1/4 (57) x 12 (305) x 50-1/8 (127cm)
-	JC2 / JE2	-	-				12	2-1/4 (57) x 12 (305) x 56-1/4 (143cm)		
-	-	JE2NFPA	-				2-1/4 (57) x 12 (305) x 56-1/4 (143cm)			
-	-	JEONFPA	-				2-1/4 (57) x 12 (305) x 62 (158cm)			
-	-	-	MJY****P				6	4		2-1/4 (57) x 12 (305) x 22 (56cm)
-	-	-	MJY****M							
-	-	-	MJY****V							

* Replace symbol (*) in color code on all models with lens or LED color desired: A=Amber; B=Blue; C=Clear; G=Green; R=Red

WHELEN

High performance, cost competitive Super-LED® lightbar with a range of options, designed for ease of operation, upgrade and serviceability. Available in Competitor™ and programmable WeCan® Series, plus NFPA certification.



Clear outer lens standard with a moisture resistant compression fit gasket. Optional color lenses available. Four corner Linear Super-LED® modules provide full 360 degree coverage, for SAE J845 Class 1 certification. Corners are available with 6 or 9 diode Super-LED modules. Optional LIN6™ or CON3™ lighthouse modules. CON3 has removable optic spreading filters for outer sections.

Center section available with optional single LIN6, CON3 or two LTR3™s (for split color center section).

Black polycarbonate base on an extruded aluminum platform for added strength.

Adjustable mount foot allows the lightbar to be mounted parallel to the street surface, no matter the shape of the vehicle roof.

Standard passenger side cable, driver side optional.

Service oriented lightbar allows easy access: • Upgrade or service lightbar right in the field

• Remove four screws to access any section of the lightbar • Change Colors

• Lighthouse replacement is as simple as removing one screw and single connector

Five year HDP® Heavy-Duty Professional warranty on LEDs.

All Justice models are 12" wide and only 2-1/4" high (without mounting feet) in three standard lengths of: 44", 50-1/8" and 56-1/4", plus a 62" Wrecker Bar.

Optional GTT Opticom™ emitter, LED brake/tail/turn and Traffic Advisors™ with control head available.

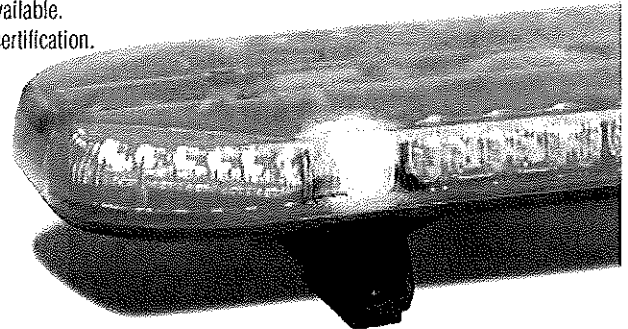

Liberty lightbars turned off have a stealth look



JC & JE Competitor Series with four corner Linear-LED® modules offering front, rear and all bar operational control of lightbar.

Justice JC Extended corner module with 9 diodes per module.

Justice JE Standard corner module with 6 diodes per module.

Standard current switching with Scan-Lock flash patterns and pattern override feature.

Choose from LIN6, LTR3 or CON3 lighthouse modules with removable optic spreading filters, for your inboard lighthoods.

Optional Scan-Lock flash patterns.

Optional LR11 Super-LED alley or take-down lights with 15° horizontal adjustment.

Optional flasher to allow take-down lights to steady-burn or flash.

Competitor Series also offers a 62" wrecker bar with standard rear work and brake/tail/turn lights.

SCANLOCK

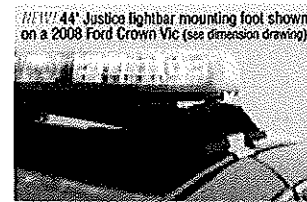

NEW! 44" Justice lightbar mounting foot shown on a 2008 Ford Crown Vic (see dimension drawing)

WE CAN JV/JY Series Programmable Lightbars

An external interface unit, the WeCan Electronic Control Module (ECM), communicates all lightbar operating functions via a 2 conductor, 20 gauge cable. This small cable provides easier overall wiring and lightbar installation. Up to eighteen different programmed warning configurations can be operated using customer supplied switching to each of eighteen input wires to the ECM (default program pre-installed).

Justice JV Extended corner module with 9 diodes per module.

Justice JY Standard corner module with 6 diodes per module.

All functions are programmed easily by your computer via simple "pick & click, or drag" screens. Windows® based 2000, XP or later operating system required. USB input to the ECM from PC or laptop makes programming easy. Once the ECM is programmed, selection of these wires will allow:

Complete independent flash pattern and "On" or "Off" phase control of each individual lighthouse.

Low current switching with multiple flash patterns.

Four phases for alternating, simultaneous and combination flash patterns.

Cruise light control with multiple adjustable intensity levels.

Independent Hi/Low control is available to any Super-LED warning lighthouse, except corner modules.

WeCan offers built-in Traffic Advisor with independent (sequential) control of the traffic arrow functions (left, right, split) without a Traffic Advisor control head.

New Optional WCC9 WeCan 6 button and slide switch control head with 10 dip switch selectable switching.

Optional 15° horizontal adjustable LR11 Super-LED flashing take-downs and alley lights.

Choose from LIN6, LTR3 or CON3 lighthouse modules with removable optic spreading filters, for your inboard lighthoods.

Optional WCC9 WeCan Controller



Electronic Control Module

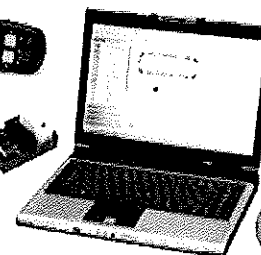

Laptop or PC is used to configure control of the lightbar

WeCan program installs into your computer via CD



"No one can control your lightbar like"

WE CAN

All the options you need to customize your lightbar. With Justice's modular design, you can add options now, and more at a later date.

JUSTICE® Super-LED® LIGHTBARS OPTIONS	Justice Option Model	WeCan® JV & JY Series				Compellor™ JE & JC Series				NFA		Mini Justice MJY Series					
		JV4****	JV8****	JV2****	JY4****	JY8****	JY2****	JE4****	JE8****	JE2****	JC4****	JC8****	JC2****	JE2NFA	JE0NFA	MJY****P	MJY****M
One CON3™	JDC*	✓	✓	✓	✓	✓	✓	✓	✓	✓	✓	✓	✓	✓	✓	✓	✓
One LTR3™ for use in center section, with take-down lights only	JDH*	✓	✓	✓	✓	✓	✓	✓	✓	✓	✓	✓	✓	✓	✓	✓	✓
One LIN6™	JDL*	✓	✓	✓	✓	✓	✓	✓	✓	✓	✓	✓	✓	✓	✓	✓	✓
<i>NEW</i> Four LR11 Super-LEDs, two steady-burn take-downs and two steady-burn alley lights for permanent models only†	MJFDALL1	-	-	-	-	-	-	-	-	-	-	-	-	-	✓	✓	✓
Two LR11 Super-LED flashing take-down lights*	JTLS1	✓	✓	✓	✓	✓	✓	✓	✓	✓	✓	✓	✓	✓	✓	✓	✓
Two LR11 Super-LED flashing alley lights*	JALF1	✓	✓	✓	✓	✓	✓	✓	✓	✓	✓	✓	✓	✓	✓	✓	✓
Two red, blue and/or amber flashing LR11 Super-LED in alley light positions*	JDLF**	✓	✓	✓	✓	✓	✓	✓	✓	✓	✓	✓	✓	✓	✓	✓	✓
One LR11 Super-LED flashing take-down lights, for single center section*	JCTLS1	✓	✓	✓	✓	✓	✓	✓	✓	✓	✓	✓	✓	✓	✓	✓	✓
Two LR11 Super-LED flashing take-down lights, for two center sections*	JCTLS12	✓	✓	✓	✓	✓	✓	✓	✓	✓	✓	✓	✓	✓	✓	✓	✓
Two super high intensity LED take-down lights	JTDLED2	✓	✓	✓	✓	✓	✓	✓	✓	✓	✓	✓	✓	✓	✓	✓	✓
Two super high intensity LED work lights	JWLLLED2	✓	✓	✓	✓	✓	✓	✓	✓	✓	✓	✓	✓	✓	✓	✓	✓
Two Super-LED external alley lights, for standard end section	JXALF1L	✓	✓	✓	✓	✓	✓	✓	✓	✓	✓	✓	✓	✓	✓	✓	✓
Two colored Super-LED modules in external alley light positions, for standard end section	JXALF**L	✓	✓	✓	✓	✓	✓	✓	✓	✓	✓	✓	✓	✓	✓	✓	✓
Two LED brake/turn/taillights	JBTLED	✓	✓	✓	✓	✓	✓	✓	✓	✓	✓	✓	✓	✓	✓	✓	✓
Two wire control Traffic Advisor, standard feature if appropriate number of lighthead are purchased	JTA2W	✓	✓	✓	✓	✓	✓	✓	✓	✓	✓	✓	✓	✓	✓	✓	✓
<i>NEW</i> Two LR11 Super-LED steady-burn alley lights*	JHALF1	-	-	-	-	-	✓	✓	✓	✓	✓	✓	✓	✓	✓	✓	✓
<i>NEW</i> Two LR11 Super-LED steady-burn take-down lights*	JHTLS2	-	-	-	-	-	✓	✓	✓	✓	✓	✓	✓	✓	✓	✓	✓
<i>NEW</i> Two LR11 Super-LED center mount steady-burn take-down lights*	JHCTLS1	-	-	-	-	-	✓	✓	✓	✓	✓	✓	✓	✓	✓	✓	✓
<i>NEW</i> Four LR11 Super-LED, two steady-burn take-downs and two steady-burn alley lights*	JHTDALL1	-	-	-	-	-	✓	✓	✓	✓	✓	✓	✓	✓	✓	✓	✓
<i>NEW</i> Four LR11 Super-LED, two center mounted steady-burn take-downs and two steady-burn alley lights*	JHCTAL1	-	-	-	-	-	✓	✓	✓	✓	✓	✓	✓	✓	✓	✓	✓
Flasher for flashing take-down or flashing work lights, please specify	JHFLASH	-	-	-	-	-	✓	✓	✓	✓	✓	✓	✓	✓	✓	✓	✓
Two LED brake/turn/taillights	JHBTTLED	-	-	-	-	-	✓	✓	✓	✓	✓	✓	✓	✓	✓	✓	✓
Traffic Advisor™, with internal/external harness, for use with TACTALD1. With lightbar purchase and used with CON3 center module only (lighthead purchased separately)	JTACNTL	✓	✓	✓	✓	✓	✓	✓	✓	✓	✓	✓	✓	✓	✓	✓	✓
Traffic Advisor with internal/external harness, for use with CCSRNTA2. With lightbar purchase and used with CON3 center module only (lighthead purchased separately)	JTACBL	✓	✓	✓	✓	✓	✓	✓	✓	✓	✓	✓	✓	✓	✓	✓	✓
GTT self-contained LED IR Opticom™ Emitter	795H	✓	✓	✓	✓	✓	✓	✓	✓	✓	✓	✓	✓	✓	✓	✓	✓
<i>NEW</i> Installation (pre-wired) of 795H into the center section. No charge when purchased with 795H	J795HC	✓	✓	✓	✓	✓	✓	✓	✓	✓	✓	✓	✓	✓	✓	✓	✓
<i>NEW</i> Installation (pre-wired) of 795H into an outer section. No charge when purchased with 795H	J795HO	✓	✓	✓	✓	✓	✓	✓	✓	✓	✓	✓	✓	✓	✓	✓	✓
Driver side cable exit, in place of passenger side	JDSCBL	✓	✓	✓	✓	✓	✓	✓	✓	✓	✓	✓	✓	✓	✓	✓	✓
18 lightbars bulk package (instead of standard individually boxed lightbars)	JBULK18	✓	✓	✓	✓	✓	✓	✓	✓	✓	✓	✓	✓	✓	✓	✓	✓
<i>NEW</i> Substitute WCC9 WeCan Controller for WeCan Electronic Control Point module, when purchased with Liberty SW WeCan Lightbars only	WCC9SUB	✓	✓	✓	✓	✓	✓	✓	✓	✓	✓	✓	✓	✓	✓	✓	✓

LEGEND: ✓ = Available

* Replace symbol (*) in color code on all models with lens color desired: A=amber, B=blue, C=clear, G=green, R=red

† LR11 with 15° horizontal adjustment



WHELEN
ENGINEERING COMPANY, INC.

51 Winthrop Road, Chester, CT 06412-0684
860-526-9504 • Fax 860-526-4078
www.whelen.com



Whelen products are proudly manufactured in the U.S.A.



Whelen Engineering Company, Inc. and may be used only as set forth in the Guidelines for Use of Whelen Trademarks available at www.whelen.com. Unauthorized use of Whelen Trademarks for commercial purposes may constitute trademark infringement and unfair competition in violation of federal and state laws.

Whelen Engineering reserves the right to upgrade and improve products without prior notice. NASCAR® is a registered trademark of the National Association for Stock Car Auto Racing, Inc. © 2009 Whelen Engineering Company, Inc. Printed in U.S.A. Code 11466F 101909

State of West Virginia

VENDOR PREFERENCE CERTIFICATE

Certification and application* is hereby made for Preference in accordance with West Virginia Code, §5A-3-37. (Does not apply to construction contracts). West Virginia Code, §5A-3-37, provides an opportunity for qualifying vendors to request (at the time of bid) preference for their residency status. Such preference is an evaluation method only and will be applied only to the cost bid in accordance with the West Virginia Code. This certificate for application is to be used to request such preference. The Purchasing Division will make the determination of the Resident Vendor Preference, if applicable.

- 1. Application is made for 2.5% resident vendor preference for the reason checked: Bidder is an individual resident vendor and has resided continuously in West Virginia for four (4) years immediately preceding the date of this certification; or, Bidder is a partnership, association or corporation resident vendor and has maintained its headquarters or principal place of business continuously in West Virginia for four (4) years immediately preceding the date of this certification; or 80% of the ownership interest of Bidder is held by another individual, partnership, association or corporation resident vendor who has maintained its headquarters or principal place of business continuously in West Virginia for four (4) years immediately preceding the date of this certification; or, Bidder is a nonresident vendor which has an affiliate or subsidiary which employs a minimum of one hundred state residents and which has maintained its headquarters or principal place of business within West Virginia continuously for the four (4) years immediately preceding the date of this certification; or,
2. Application is made for 2.5% resident vendor preference for the reason checked: Bidder is a resident vendor who certifies that, during the life of the contract, on average at least 75% of the employees working on the project being bid are residents of West Virginia who have resided in the state continuously for the two years immediately preceding submission of this bid; or,
3. Application is made for 2.5% resident vendor preference for the reason checked: Bidder is a nonresident vendor employing a minimum of one hundred state residents or is a nonresident vendor with an affiliate or subsidiary which maintains its headquarters or principal place of business within West Virginia employing a minimum of one hundred state residents who certifies that, during the life of the contract, on average at least 75% of the employees or Bidder's affiliate's or subsidiary's employees are residents of West Virginia who have resided in the state continuously for the two years immediately preceding submission of this bid; or,
4. Application is made for 5% resident vendor preference for the reason checked: Bidder meets either the requirement of both subdivisions (1) and (2) or subdivision (1) and (3) as stated above; or,
5. Application is made for 3.5% resident vendor preference who is a veteran for the reason checked: Bidder is an individual resident vendor who is a veteran of the United States armed forces, the reserves or the National Guard and has resided in West Virginia continuously for the four years immediately preceding the date on which the bid is submitted; or,
6. Application is made for 3.5% resident vendor preference who is a veteran for the reason checked: Bidder is a resident vendor who is a veteran of the United States armed forces, the reserves or the National Guard, if, for purposes of producing or distributing the commodities or completing the project which is the subject of the vendor's bid and continuously over the entire term of the project, on average at least seventy-five percent of the vendor's employees are residents of West Virginia who have resided in the state continuously for the two immediately preceding years.

Bidder understands if the Secretary of Revenue determines that a Bidder receiving preference has failed to continue to meet the requirements for such preference, the Secretary may order the Director of Purchasing to: (a) reject the bid; or (b) assess a penalty against such Bidder in an amount not to exceed 5% of the bid amount and that such penalty will be paid to the contracting agency or deducted from any unpaid balance on the contract or purchase order.

By submission of this certificate, Bidder agrees to disclose any reasonably requested information to the Purchasing Division and authorizes the Department of Revenue to disclose to the Director of Purchasing appropriate information verifying that Bidder has paid the required business taxes, provided that such information does not contain the amounts of taxes paid nor any other information deemed by the Tax Commissioner to be confidential.

Under penalty of law for false swearing (West Virginia Code, §61-5-3), Bidder hereby certifies that this certificate is true and accurate in all respects; and that if a contract is issued to Bidder and if anything contained within this certificate changes during the term of the contract, Bidder will notify the Purchasing Division in writing immediately.

Bidder: Electronic Communications of WVU Signed: [Signature]
Date: Sept 6 2011 Title: President

*Check any combination of preference consideration(s) indicated above, which you are entitled to receive.