



State of West Virginia  
 Department of Administration  
 Purchasing Division  
 2019 Washington Street East  
 Post Office Box 50130  
 Charleston, WV 25305-0130

# Request for Quotation

RFQ NUMBER  
 70125010

PAGE  
 1

ADDRESS CORRESPONDENCE TO ATTENTION OF:  
 ALAN CUMMINGS  
 304-558-2402

VENDOR

\*709042843 304-984-9487  
 MCCLANAHAN SERVICE INC  
 59 TEAKWOOD LN  
 SISSONVILLE WV 25320

SHIP TO

DIVISION OF HIGHWAYS  
 JOBSITE  
 SEE SPECIFICATIONS

DATE PRINTED	TERMS OF SALE	SHIP VIA	F.O.B.	FREIGHT TERMS
06/01/2012				

BID OPENING DATE: 06/13/2012 BID OPENING TIME 01:30PM

LINE	QUANTITY	UOP	CAT. NO.	ITEM NUMBER	UNIT PRICE	AMOUNT
0001	1	LS		830-55	25,539.30	25,539.30
ABOVE GROUND STORAGE TANK WITH ACCESSORIES  THE WEST VIRGINIA STATE PURCHASING DIVISION FOR THE AGENCY, THE WEST VIRGINIA DIVISION OF HIGHWAYS, IS SOLICITING BIDS TO PROVIDE THE AGENCY ONE, 4000 GALLON, 2 COMPARTMENT ABOVE GROUND STORAGE TANK WITH ACCESSORIES FOR THE ATTACHED SPECIFICATIONS.  CANCELLATION: THE DIRECTOR OF PURCHASING RESERVES THE RIGHT TO CANCEL THIS CONTRACT IMMEDIATELY UPON WRITTEN NOTICE TO THE VENDOR IF THE COMMODITIES AND/OR SERVICES SUPPLIED ARE OF AN INFERIOR QUALITY OR DO NOT CONFORM TO THE SPECIFICATIONS OF THE BID AND CONTRACT HEREIN.  BANKRUPTCY: IN THE EVENT THE VENDOR/CONTRACTOR FILES FOR BANKRUPTCY PROTECTION, THE STATE MAY DEEM THE CONTRACT NULL AND VOID, AND TERMINATE SUCH CONTRACT WITHOUT FURTHER ORDER.  THE MODEL/BRAND/SPECIFICATIONS NAMED HEREIN ESTABLISH THE ACCEPTABLE LEVEL OF QUALITY ONLY AND ARE NOT INTENDED TO REFLECT A PREFERENCE OR FAVOR ANY PARTICULAR BRAND OR VENDOR. VENDORS WHO ARE BIDDING ALTERNATES SHOULD SO STATE AND INCLUDE PERTINENT LITERATURE AND SPECIFICATIONS. FAILURE TO PROVIDE INFORMATION FOR ANY ALTERNATES MAY BE GROUNDS FOR REJECTION OF THE BID. THE STATE RESERVES THE RIGHT TO WAIVE MINOR IRREGULARITIES IN BIDS OR SPECIFICATIONS IN ACCORDANCE WITH SECTION 148-1-4(F) OF THE WEST VIRGINIA LEGISLATIVE RULES AND REGULATIONS.						

RECEIVED  
 2012 JUN 11 AM 10:00  
 WV PURCHASING DIVISION

SEE REVERSE SIDE FOR TERMS AND CONDITIONS			
SIGNATURE <i>Cynthia Marion</i>	TELEPHONE 304-984-9487	DATE 6-8-12	
TITLE <i>Secretary</i>	FEIN 55-0527361	ADDRESS CHANGES TO BE NOTED ABOVE	

WHEN RESPONDING TO RFQ, INSERT NAME AND ADDRESS IN SPACE ABOVE LABELED 'VENDOR'

**GENERAL TERMS & CONDITIONS**  
**REQUEST FOR QUOTATION (RFQ) AND REQUEST FOR PROPOSAL (RFP)**

1. Awards will be made in the best interest of the State of West Virginia.
2. The State may accept or reject in part, or in whole, any bid.
3. Prior to any award, the apparent successful vendor must be properly registered with the Purchasing Division and have paid the required \$125 fee.
4. All services performed or goods delivered under State Purchase Order/Contracts are to be continued for the term of the Purchase Order/Contracts, contingent upon funds being appropriated by the Legislature or otherwise being made available. In the event funds are not appropriated or otherwise available for these services or goods this Purchase Order/Contract becomes void and of no effect after June 30.
5. Payment may only be made after the delivery and acceptance of goods or services.
6. Interest may be paid for late payment in accordance with the *West Virginia Code*.
7. Vendor preference will be granted upon written request in accordance with the *West Virginia Code*.
8. The State of West Virginia is exempt from federal and state taxes and will not pay or reimburse such taxes.
9. The Director of Purchasing may cancel any Purchase Order/Contract upon 30 days written notice to the seller.
10. The laws of the State of West Virginia and the *Legislative Rules* of the Purchasing Division shall govern the purchasing process.
11. Any reference to automatic renewal is hereby deleted. The Contract may be renewed only upon mutual written agreement of the parties.
12. **BANKRUPTCY:** In the event the vendor/contractor files for bankruptcy protection, the State may deem this contract null and void, and terminate such contract without further order.
13. **HIPAA BUSINESS ASSOCIATE ADDENDUM:** The West Virginia State Government HIPAA Business Associate Addendum (BAA), approved by the Attorney General, is available online at [www.state.wv.us/admin/purchase/vrc/hipaa.html](http://www.state.wv.us/admin/purchase/vrc/hipaa.html) and is hereby made part of the agreement provided that the Agency meets the definition of a Cover Entity (45 CFR §160.103) and will be disclosing Protected Health Information (45 CFR §160.103) to the vendor.
14. **CONFIDENTIALITY:** The vendor agrees that he or she will not disclose to anyone, directly or indirectly, any such personally identifiable information or other confidential information gained from the agency, unless the individual who is the subject of the information consents to the disclosure in writing or the disclosure is made pursuant to the agency's policies, procedures, and rules. Vendor further agrees to comply with the Confidentiality Policies and Information Security Accountability Requirements, set forth in <http://www.state.wv.us/admin/purchase/privacy/noticeConfidentiality.pdf>.
15. **LICENSING:** Vendors must be licensed and in good standing in accordance with any and all state and local laws and requirements by any state or local agency of West Virginia, including, but not limited to, the West Virginia Secretary of State's Office, the West Virginia Tax Department, and the West Virginia Insurance Commission. The vendor must provide all necessary releases to obtain information to enable the director or spending unit to verify that the vendor is licensed and in good standing with the above entities.
16. **ANTITRUST:** In submitting a bid to any agency for the State of West Virginia, the bidder offers and agrees that if the bid is accepted the bidder will convey, sell, assign or transfer to the State of West Virginia all rights, title and interest in and to all causes of action it may now or hereafter acquire under the antitrust laws of the United States and the State of West Virginia for price fixing and/or unreasonable restraints of trade relating to the particular commodities or services purchased or acquired by the State of West Virginia. Such assignment shall be made and become effective at the time the purchasing agency tenders the initial payment to the bidder.

I certify that this bid is made without prior understanding, agreement, or connection with any corporation, firm, limited liability company, partnership, or person or entity submitting a bid for the same material, supplies, equipment or services and is in all respects fair and without collusion or Fraud. I further certify that I am authorized to sign the certification on behalf of the bidder or this bid.

---

**INSTRUCTIONS TO BIDDERS**

1. Use the quotation forms provided by the Purchasing Division. Complete all sections of the quotation form.
2. Items offered must be in compliance with the specifications. Any deviation from the specifications must be clearly indicated by the bidder. Alternates offered by the bidder as **EQUAL** to the specifications must be clearly defined. A bidder offering an alternate should attach complete specifications and literature to the bid. The Purchasing Division may waive minor deviations to specifications.
3. Unit prices shall prevail in case of discrepancy. All quotations are considered F.O.B. destination unless alternate shipping terms are clearly identified in the quotation.
4. All quotations must be delivered by the bidder to the office listed below prior to the date and time of the bid opening. Failure of the bidder to deliver the quotations on time will result in bid disqualifications: Department of Administration, Purchasing Division, 2019 Washington Street East, P.O. Box 50130, Charleston, WV 25305-0130
5. Communication during the solicitation, bid, evaluation or award periods, except through the Purchasing Division, is strictly prohibited (W.Va. C.S.R. §148-1-6.6).



State of West Virginia  
 Department of Administration  
 Purchasing Division  
 2019 Washington Street East  
 Post Office Box 50130  
 Charleston, WV 25305-0130

# Request for Quotation

RFQ NUMBER
70125010

PAGE
2

ADDRESS CORRESPONDENCE TO ATTENTION OF:
ALAN CUMMINGS 304-558-2402

VENDOR

\*709042843      304-984-9487  
 MCCLANAHAN SERVICE INC  
 59 TEAKWOOD LN  
 SISSONVILLE WV 25320

SHIP TO

DIVISION OF HIGHWAYS  
 JOBSITE  
 SEE SPECIFICATIONS

DATE PRINTED	TERMS OF SALE	SHIP VIA	F.O.B.	FREIGHT TERMS
06/01/2012				

BID OPENING DATE: 06/13/2012      BID OPENING TIME 01:30PM

LINE	QUANTITY	UOP	CAT NO	ITEM NUMBER	UNIT PRICE	AMOUNT
NOTICE						
A SIGNED BID MUST BE SUBMITTED TO:						
DEPARTMENT OF ADMINISTRATION PURCHASING DIVISION BUILDING 15 2019 WASHINGTON STREET, EAST CHARLESTON, WV 25305-0130						
THE BID SHOULD CONTAIN THIS INFORMATION ON THE FACE OF THE ENVELOPE OR THE BID MAY NOT BE CONSIDERED:						
SEALED BID						
BUYER: ALAN CUMMINGS - FILE 33						
RFQ. NO.: 70125010						
BID OPENING DATE: 06/13/2012						
BID OPENING TIME: 1:30 P.M.						
PLEASE PROVIDE A FAX NUMBER IN CASE IT IS NECESSARY TO CONTACT YOU REGARDING YOUR BID:						
----- 304-984-9488 -----						
CONTACT PERSON (PLEASE PRINT CLEARLY):						

SEE REVERSE SIDE FOR TERMS AND CONDITIONS

SIGNATURE <i>Cynthia Mariani</i>	TELEPHONE 304-984-9487	DATE 6-8-12
TITLE <i>Secretary</i>	FEIN 55-0527361	ADDRESS CHANGES TO BE NOTED ABOVE

WHEN RESPONDING TO RFQ, INSERT NAME AND ADDRESS IN SPACE ABOVE LABELED 'VENDOR'



State of West Virginia  
 Department of Administration  
 Purchasing Division  
 2019 Washington Street East  
 Post Office Box 50130  
 Charleston, WV 25305-0130

# Request for Quotation

RFQ NUMBER  
 70125010

PAGE  
 3

ADDRESS CORRESPONDENCE TO ATTENTION OF:  
 ALAN CUMMINGS  
 304-558-2402

VENDOR \*709042843 304-984-9487  
 MCCLANAHAN SERVICE INC  
 59 TEAKWOOD LN  
 SISSONVILLE WV 25320

SHIP TO  
 DIVISION OF HIGHWAYS  
 JOBSITE  
 SEE SPECIFICATIONS

DATE PRINTED	TERMS OF SALE	SHIP VIA	F.O.B.	FREIGHT TERMS
06/01/2012				

BID OPENING DATE: 06/13/2012 BID OPENING TIME 01:30PM

LINE	QUANTITY	UOP	CAT. NO.	ITEM NUMBER	UNIT PRICE	AMOUNT
				----- OTHER MCCLANAHAN SR		
ANY INDIVIDUAL SIGNING THIS BID IS CERTIFYING THAT: (1) HE OR SHE IS AUTHORIZED BY THE BIDDER TO EXECUTE THE BID OR ANY DOCUMENTS RELATED THERETO ON BEHALF OF THE BIDDER, (2) THAT HE OR SHE IS AUTHORIZED TO BIND THE BIDDER IN A CONTRACTUAL RELATIONSHIP, AND (3) THAT THE BIDDER HAS PROPERLY REGISTERED WITH ANY STATE AGENCIES THAT MAY REQUIRE REGISTRATION.						
***** THIS IS THE END OF RFQ 70125010 ***** TOTAL:						<u>25,539.30</u>

SEE REVERSE SIDE FOR TERMS AND CONDITIONS

SIGNATURE <i>Cynthia Marion</i>	TELEPHONE 304-984-9488	DATE 6-8-12
TITLE <i>Secretary</i>	FEIN 55-0527361	ADDRESS CHANGES TO BE NOTED ABOVE

WHEN RESPONDING TO RFQ, INSERT NAME AND ADDRESS IN SPACE ABOVE LABELED 'VENDOR'

**Stanwade Metal 4000 Gl. Above Ground  
Storage Tank or Equal – Specifications**

**70125010**

**I. PURPOSE AND SCOPE:**

The WVDOT/Equipment Division, is soliciting bids to establish a contract for the one time purchase of a 4000 gallon/2 compartment above ground storage tank.

**II. DEFINITIONS:**

The terms listed below shall have the meanings assigned to them as follows:

1. "Agency" or "Agencies" means WVDOT/Equipment Division.
2. "Contract" means the binding agreement that is entered into between the State and the Vendor to provide the Desired Items as specified herein.
3. "Desired Item" or "Desired Items" means the list of items identified in Section III, Subsection 1 below.
4. "Bid Evaluation Page" means the page upon which Vendor should list its proposed price for the Desired Items in the manner requested thereon. The Bid Evaluation Page is attached hereto as Exhibit A.
5. "Purchasing Division" means the West Virginia Department of Administration, Purchasing Division.
6. "RFQ" means the official RFQ published by the Purchasing Division and identified as 70125010.
7. "State" means the State of West Virginia and/or any of its agencies, commissions, boards, etc.
8. "Vendor" or "Vendors" means the successful bidder(s).

**III. GENERAL REQUIREMENTS**

1. **Desired Items and Mandatory Requirements:** Vendor shall provide Agency with the Desired Item listed below. The Desired Item must meet or exceed the mandatory requirements as shown below.

**Stanwade Metal 4000 Gl. Above Ground  
Storage Tank or Equal – Specifications**

**70125010**

- A. (1) 4000 gallon 2 compartment (2k/2k) (96" dia. x 134" long) Flameshield UL 142, Double-Wall Aboveground Storage Tank with Saddles.
1. Must meet NFPA-30 code (fire resistant)
  2. Blast and coat white urethane
- B. Must have the following accessories to accompany Tank
1. (2) Decal Kits (Diesel/Gas)
  2. (2) Pump Platforms
  3. (2) 108" Stairways and Platform
  4. (2) Baker Fill Containment Stands with (2) 3" Remote Fill Bottom Limiters w/shut off.
  5. Vent Kit required: (2) Emergency Vents (1 Primary/1 Secondary) and (2) Standard Nominal Vents.
  6. (2) Morrison Clock Gauges
  7. (1) At-A-Glance Leak Gauge (Secondary)
  8. (1) Gemkit Leak Sensor Kit
  9. (2) Gasboy Astra Suction Pump 9823K w/remote Dispenser, hose, nozzle and swivel.

**IV. CONTRACT AWARD**

1. **Contract Award:** The Contract is intended to provide Agencies with a purchase price for the Desired Items listed above. The Contract shall be awarded to the Vendor that provides the Desired Item meeting the required specifications for the lowest overall total cost.
2. **Bid Evaluation Page:** Vendor should complete the Bid Evaluation Page by inserting the quoted price in the space provided. The vendor should then multiply the estimated quantity by the quoted price to obtain the total price to the agency. After obtaining the total cost to the agency for each item listed, the column containing the total cost to the agency should be added together to arrive at the grand total. (Estimated Quantity X quoted price = Total price to Agency) (Sum of

**Stanwade Metal 4000 Gl. Above Ground  
Storage Tank or Equal – Specifications**

**70125010**

total cost to Agency for the item=Grand Total. Vendor should complete the Bid Evaluation Page in full as failure to complete the Bid Evaluation Page in its entirety may result in Vendor's bid being disqualified.

Notwithstanding the foregoing, the Purchasing Division may correct errors as it deems appropriate. Vendor should type or electronically enter the information into the Bid Evaluation Page to prevent errors in the evaluation.

**V. PAYMENT**

1. **Payment:** Vendor shall accept payment in accordance with the payment procedures of the State of West Virginia. Payment in advance is not permitted under this Contract.

**VI. DELIVERY AND RETURN**

1. **Shipment and Delivery:** Vendor should deliver the Desired Items within 60 to 90 working days after receiving a purchase order or notice to proceed. Desired Items must be delivered to agency at Heaters Substation Rt. 19, Heaters, WV 26627.
2. **Late Delivery:** The Agency placing the order under this Contract must be notified in writing if the shipment of the Desired Items will be delayed for any reason. Any delay in delivery that could cause harm to an Agency will be grounds for:
  - (a) cancellation of the Contract, and
  - (b) obtaining the Desired Items from a third party.

Any Agency seeking to obtain the Desired Items from a third party under this provision must first obtain approval of the Purchasing Division.

3. **Delivery Cost/Risk of Loss:** Vendor shall deliver the Desired Items F.O.B. destination to the Agency's location or locations identified above.
4. **Return of Unacceptable Items:** If the Agency deems the Desired Items to be unacceptable, the Desired Items shall be returned to Vendor at Vendor's expense and with no restocking charge. Vendor shall either make arrangements for the return within five (5) days of being notified that items are unacceptable, or permit the Agency to arrange for the return and reimburse Agency for delivery expenses. If the original packaging cannot be utilized for the return, Vendor will supply the Agency with

## REQUEST FOR QUOTATION

**Stanwade Metal 4000 Gl. Above Ground  
Storage Tank or Equal – Specifications****70125010**

appropriate return packaging upon request. All returns of unacceptable items shall be F.O.B. the Agency's location. The returned product shall either be replaced, or the Agency shall receive a full credit or refund for the purchase price, at the Agency's discretion.

**VII. MISCELLANIOUS**

1. **Mandatory Requirements:** The terms "must," "will," "shall," "minimum," "maximum," or "is/are required" identify a mandatory contract requirement. Decisions regarding compliance with any mandatory requirements shall be at the sole discretion of the Purchasing Division. Failure on the part of the Vendor to meet any of the mandatory specifications shall result in disqualification of the bid.
2. **Waiver:** The failure of either party to insist upon a strict performance of any of the terms or provision of this Contract, or to exercise any option, right, or remedy herein contained, shall not be construed as a waiver or a relinquishment for the future of such term, provision, option, right, or remedy, but the same shall continue in remain in full force and effect. Any waiver must be expressly stated in writing and signed by the waiving party.



# Note: With Stairs PLATFORM RAILS REVISED DRAWING

**Stonwade Metal Products, Inc.**  
 5868 State Route 305 PO Box 10  
 Hartford, Ohio 44424  
 Phone 800-826-5243 Fax 1-338-772-3307  
 www.stonwade.com

Capacity 4,000 Gallons  
 Design Dual Vol 15  
 Code UD142 Flomestall  
 Test Pres. 5 PSI

Part Ext. White Urethane  
 Part Int.  
 Weight Empty 9,000 lbs.  
 Rev.# 1 Date: 9-6-11

Heads Primary 1/4"  
 Shell Primary 1/4"  
 Heads Secondary 1/4"  
 Shell Secondary 10 Ga.

Tank For Stationary Use Only



2 Compartments  
 2,000 > 2,000

36" x 36" Platform

18" Nowsay  
 w/6" Primary EV  
 & (1) 4" opening  
 opening in lid



Flanged  
 4" EV  
 opening



18" Nowsay  
 w/6" Primary EV  
 & (3) 4" openings  
 opening in lid

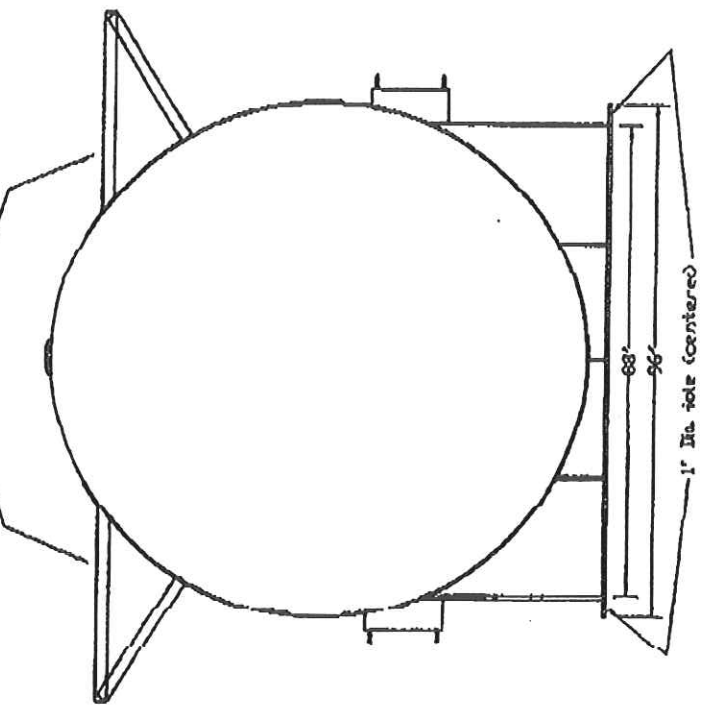
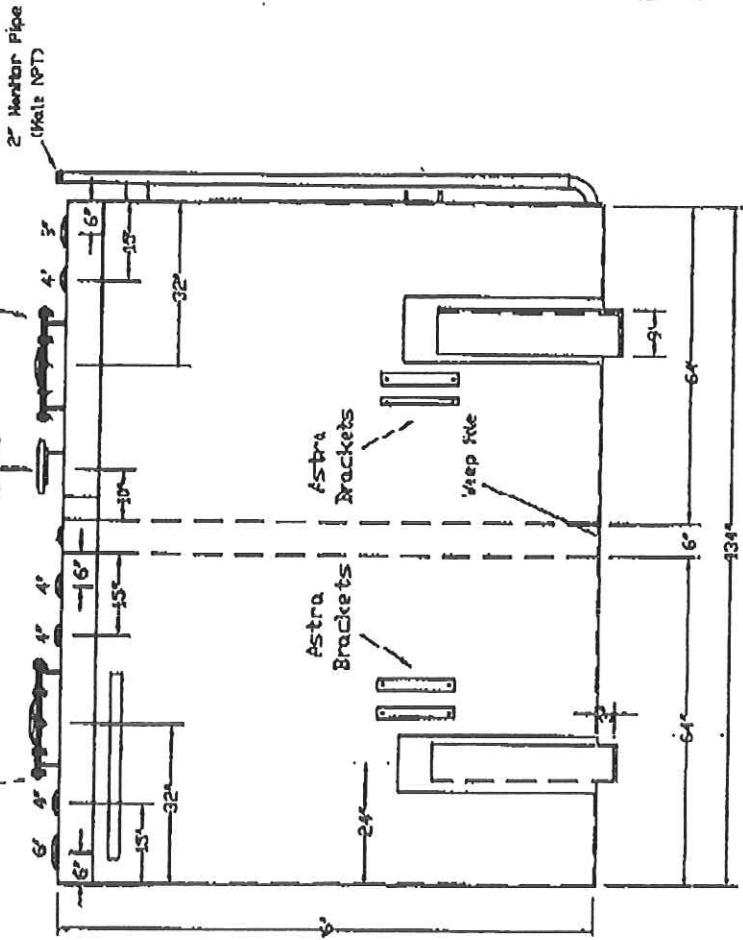

00253110

Customer: \_\_\_\_\_  
 Date: 8-31-11  
 Drawing Approved By: \_\_\_\_\_  
 Quoted Lead Times Begin Upon Receipt of signed Approved Drawing, Which Must be Returned before Production Can Begin.

## Exhibit A: Cost Sheet

Item No.	Quantity	Unit of Measure	Stan wade Tanks & Accessories	"Or Equal" Part	Price Delivered	Amount
1	1	Lump Sum	Description: 4000 Gal. Tank	Highland Tank 412 142 Double Flame Shield Description:	\$ 25,539.30	\$ 25,539.30
					TOTAL:	\$ 25,539.30

# VENDOR PREFERENCE CERTIFICATE

Certification and application\* is hereby made for Preference in accordance with *West Virginia Code*, §5A-3-37. (Does not apply to construction contracts). *West Virginia Code*, §5A-3-37, provides an opportunity for qualifying vendors to request (at the time of bid) preference for their residency status. Such preference is an evaluation method only and will be applied only to the cost bid in accordance with the *West Virginia Code*. This certificate for application is to be used to request such preference. The Purchasing Division will make the determination of the Resident Vendor Preference, if applicable.

- 1. **Application is made for 2.5% resident vendor preference for the reason checked:**  
 Bidder is an individual resident vendor and has resided continuously in West Virginia for four (4) years immediately preceding the date of this certification; **or**,  
 Bidder is a partnership, association or corporation resident vendor and has maintained its headquarters or principal place of business continuously in West Virginia for four (4) years immediately preceding the date of this certification; **or** 80% of the ownership interest of Bidder is held by another individual, partnership, association or corporation resident vendor who has maintained its headquarters or principal place of business continuously in West Virginia for four (4) years immediately preceding the date of this certification; **or**,  
 Bidder is a nonresident vendor which has an affiliate or subsidiary which employs a minimum of one hundred state residents and which has maintained its headquarters or principal place of business within West Virginia continuously for the four (4) years immediately preceding the date of this certification; **or**,
- 2. **Application is made for 2.5% resident vendor preference for the reason checked:**  
 Bidder is a resident vendor who certifies that, during the life of the contract, on average at least 75% of the employees working on the project being bid are residents of West Virginia who have resided in the state continuously for the two years immediately preceding submission of this bid; **or**,
- 3. **Application is made for 2.5% resident vendor preference for the reason checked:**  
 Bidder is a nonresident vendor employing a minimum of one hundred state residents or is a nonresident vendor with an affiliate or subsidiary which maintains its headquarters or principal place of business within West Virginia employing a minimum of one hundred state residents who certifies that, during the life of the contract, on average at least 75% of the employees or Bidder's affiliate's or subsidiary's employees are residents of West Virginia who have resided in the state continuously for the two years immediately preceding submission of this bid; **or**,
- 4. **Application is made for 5% resident vendor preference for the reason checked:**  
 Bidder meets either the requirement of both subdivisions (1) and (2) or subdivision (1) and (3) as stated above; **or**,
- 5. **Application is made for 3.5% resident vendor preference who is a veteran for the reason checked:**  
 Bidder is an individual resident vendor who is a veteran of the United States armed forces, the reserves or the National Guard and has resided in West Virginia continuously for the four years immediately preceding the date on which the bid is submitted; **or**,
- 6. **Application is made for 3.5% resident vendor preference who is a veteran for the reason checked:**  
 Bidder is a resident vendor who is a veteran of the United States armed forces, the reserves or the National Guard, if, for purposes of producing or distributing the commodities or completing the project which is the subject of the vendor's bid and continuously over the entire term of the project, on average at least seventy-five percent of the vendor's employees are residents of West Virginia who have resided in the state continuously for the two immediately preceding years.

Bidder understands if the Secretary of Revenue determines that a Bidder receiving preference has failed to continue to meet the requirements for such preference, the Secretary may order the Director of Purchasing to: (a) reject the bid; or (b) assess a penalty against such Bidder in an amount not to exceed 5% of the bid amount and that such penalty will be paid to the contracting agency or deducted from any unpaid balance on the contract or purchase order.

By submission of this certificate, Bidder agrees to disclose any reasonably requested information to the Purchasing Division and authorizes the Department of Revenue to disclose to the Director of Purchasing appropriate information verifying that Bidder has paid the required business taxes, provided that such information does not contain the amounts of taxes paid nor any other information deemed by the Tax Commissioner to be confidential.

Under penalty of law for false swearing (*West Virginia Code*, §61-5-3), Bidder hereby certifies that this certificate is true and accurate in all respects; and that if a contract is issued to Bidder and if anything contained within this certificate changes during the term of the contract, Bidder will notify the Purchasing Division in writing immediately.

Bidder: Cynthia Marion Signed: Cynthia Marion  
 Date: 6-8-12 Title: Secretary

\*Check any combination of preference consideration(s) indicated above, which you are entitled to receive.

STATE OF WEST VIRGINIA  
Purchasing Division

**PURCHASING AFFIDAVIT**

West Virginia Code §5A-3-10a states: No contract or renewal of any contract may be awarded by the state or any of its political subdivisions to any vendor or prospective vendor when the vendor or prospective vendor or a related party to the vendor or prospective vendor is a debtor and the debt owed is an amount greater than one thousand dollars in the aggregate.

**DEFINITIONS:**

"Debt" means any assessment, premium, penalty, fine, tax or other amount of money owed to the state or any of its political subdivisions because of a judgment, fine, permit violation, license assessment, defaulted workers' compensation premium, penalty or other assessment presently delinquent or due and required to be paid to the state or any of its political subdivisions, including any interest or additional penalties accrued thereon.

"Debtor" means any individual, corporation, partnership, association, limited liability company or any other form or business association owing a debt to the state or any of its political subdivisions. "Political subdivision" means any county commission; municipality; county board of education; any instrumentality established by a county or municipality; any separate corporation or instrumentality established by one or more counties or municipalities, as permitted by law; or any public body charged by law with the performance of a government function or whose jurisdiction is coextensive with one or more counties or municipalities. "Related party" means a party, whether an individual, corporation, partnership, association, limited liability company or any other form or business association or other entity whatsoever, related to any vendor by blood, marriage, ownership or contract through which the party has a relationship of ownership or other interest with the vendor so that the party will actually or by effect receive or control a portion of the benefit, profit or other consideration from performance of a vendor contract with the party receiving an amount that meets or exceed five percent of the total contract amount.

**EXCEPTION:** The prohibition of this section does not apply where a vendor has contested any tax administered pursuant to chapter eleven of this code, workers' compensation premium, permit fee or environmental fee or assessment and the matter has not become final or where the vendor has entered into a payment plan or agreement and the vendor is not in default of any of the provisions of such plan or agreement.

Under penalty of law for false swearing (*West Virginia Code §61-5-3*), it is hereby certified that the vendor affirms and acknowledges the information in this affidavit and is in compliance with the requirements as stated.

**WITNESS THE FOLLOWING SIGNATURE**

Vendor's Name: M<sup>rs</sup> Claxton Service Inc.

Authorized Signature: Cynthia Mariax Date: 6-8-12

State of WV

County of Kanawha, to-wit:

Taken, subscribed, and sworn to before me this 8<sup>th</sup> day of June, 2012.

My Commission expires Jan. 16, 2022.



NOTARY PUBLIC Jana Wood