



State of West Virginia  
 Department of Administration  
 Purchasing Division  
 2019 Washington Street East  
 Post Office Box 50130  
 Charleston, WV 25305-0130

# Request for Quotation

RFQ NUMBER
6612C009

PAGE
1

ADDRESS CORRESPONDENCE TO ATTENTION OF:
PAUL REYNOLDS 804-558-0468

VENDOR

LOG CABIN FENCE COMPANY  
 411 TEN MILE ROAD  
 AMITY PA 15311

SHIP TO

DIVISION OF HIGHWAYS  
 VARIOUS LOCALES AS INDICATED  
 BY ORDER

DATE PRINTED	TERMS OF SALE	SHIP VIA	F.O.B.	FREIGHT TERMS
11/14/2011				

BID OPENING DATE: 12/07/2011 BID OPENING TIME 01:30PM

LINE	QUANTITY	UOP	CAT NO.	ITEM NUMBER	UNIT PRICE	AMOUNT
0001				570-68		
SINGLE SPAN FABRIC, STEEL FRAMED BLDG ROOF SYSTEM  REQUEST FOR QUOTATION  OPEN END CONTRACT  THE WEST VIRGINIA STATE PURCHASING DIVISION FOR THE AGENCY, THE WEST VIRGINIA STATE DIVISION OF HIGHWAYS IS SOLICITING BIDS FOR AN OPEN END CONTRACT TO PROVIDE ALL MATERIALS FOR SINGLE SPAN ARCH FABRIC COVERED STEEL FRAMED BUILDING ROOF SYSTEMS TO VARIOUS SALT SHED BUILDING SITE LOCATIONS PER THE ATTACHED SPECIFICATIONS  EXHIBIT 1  LIFE OF CONTRACT: THIS CONTRACT BECOMES EFFECTIVE UPON AWARD AND EXTENDS FOR A PERIOD OF ONE (1) YEAR OR UNTIL SUCH "REASONABLE TIME" THEREAFTER AS IS NECESSARY TO OBTAIN A NEW CONTRACT OR RENEW THE ORIGINAL CONTRACT. THE "REASONABLE TIME" PERIOD SHALL NOT EXCEED TWELVE (12) MONTHS. DURING THIS "REASONABLE TIME" THE VENDOR MAY TERMINATE THIS CONTRACT FOR ANY REASON UPON GIVING THE DIRECTOR OF PURCHASING 30 DAYS WRITTEN NOTICE.  UNLESS SPECIFIC PROVISIONS ARE STIPULATED ELSEWHERE IN THIS CONTRACT DOCUMENT BY THE STATE OF WEST VIRGINIA, ITS AGENCIES, OR POLITICAL SUBDIVISIONS, THE TERMS, CONDITIONS AND PRICING SET FORTH HEREIN ARE FIRM FOR THE LIFE OF THE CONTRACT.						



SEE REVERSE SIDE FOR TERMS AND CONDITIONS

SIGNATURE	TELEPHONE	DATE
TITLE	FEIN	ADDRESS CHANGES TO BE NOTED ABOVE

WHEN RESPONDING TO RFQ, INSERT NAME AND ADDRESS IN SPACE ABOVE LABELED 'VENDOR'

**GENERAL TERMS & CONDITIONS**  
**REQUEST FOR QUOTATION (RFQ) AND REQUEST FOR PROPOSAL (RFP)**

1. Awards will be made in the best interest of the State of West Virginia.
2. The State may accept or reject in part, or in whole, any bid.
3. Prior to any award, the apparent successful vendor must be properly registered with the Purchasing Division and have paid the required \$125 fee.
4. All services performed or goods delivered under State Purchase Order/Contracts are to be continued for the term of the Purchase Order/Contracts, contingent upon funds being appropriated by the Legislature or otherwise being made available. In the event funds are not appropriated or otherwise available for these services or goods this Purchase Order/Contract becomes void and of no effect after June 30.
5. Payment may only be made after the delivery and acceptance of goods or services.
6. Interest may be paid for late payment in accordance with the *West Virginia Code*.
7. Vendor preference will be granted upon written request in accordance with the *West Virginia Code*.
8. The State of West Virginia is exempt from federal and state taxes and will not pay or reimburse such taxes.
9. The Director of Purchasing may cancel any Purchase Order/Contract upon 30 days written notice to the seller.
10. The laws of the State of West Virginia and the *Legislative Rules* of the Purchasing Division shall govern the purchasing process.
11. Any reference to automatic renewal is hereby deleted. The Contract may be renewed only upon mutual written agreement of the parties.
12. **BANKRUPTCY:** In the event the vendor/contractor files for bankruptcy protection, the State may deem this contract null and void, and terminate such contract without further order.
13. **HIPAA BUSINESS ASSOCIATE ADDENDUM:** The West Virginia State Government HIPAA Business Associate Addendum (BAA), approved by the Attorney General, is available online at [www.state.wv.us/admin/purchase/vrc/hipaa.html](http://www.state.wv.us/admin/purchase/vrc/hipaa.html) and is hereby made part of the agreement provided that the Agency meets the definition of a Cover Entity (45 CFR §160.103) and will be disclosing Protected Health Information (45 CFR §160.103) to the vendor.
14. **CONFIDENTIALITY:** The vendor agrees that he or she will not disclose to anyone, directly or indirectly, any such personally identifiable information or other confidential information gained from the agency, unless the individual who is the subject of the information consents to the disclosure in writing or the disclosure is made pursuant to the agency's policies, procedures, and rules. Vendor further agrees to comply with the Confidentiality Policies and Information Security Accountability Requirements, set forth in <http://www.state.wv.us/admin/purchase/privacy/noticeConfidentiality.pdf>.
15. **LICENSING:** Vendors must be licensed and in good standing in accordance with any and all state and local laws and requirements by any state or local agency of West Virginia, including, but not limited to, the West Virginia Secretary of State's Office, the West Virginia Tax Department, and the West Virginia Insurance Commission. The vendor must provide all necessary releases to obtain information to enable the director or spending unit to verify that the vendor is licensed and in good standing with the above entities.
16. **ANTITRUST:** In submitting a bid to any agency for the State of West Virginia, the bidder offers and agrees that if the bid is accepted the bidder will convey, sell, assign or transfer to the State of West Virginia all rights, title and interest in and to all causes of action it may now or hereafter acquire under the antitrust laws of the United States and the State of West Virginia for price fixing and/or unreasonable restraints of trade relating to the particular commodities or services purchased or acquired by the State of West Virginia. Such assignment shall be made and become effective at the time the purchasing agency tenders the initial payment to the bidder.

I certify that this bid is made without prior understanding, agreement, or connection with any corporation, firm, limited liability company, partnership, or person or entity submitting a bid for the same material, supplies, equipment or services and is in all respects fair and without collusion or fraud. I further certify that I am authorized to sign the certification on behalf of the bidder or this bid.

---

**INSTRUCTIONS TO BIDDERS**

1. Use the quotation forms provided by the Purchasing Division. Complete all sections of the quotation form.
2. Items offered must be in compliance with the specifications. Any deviation from the specifications must be clearly indicated by the bidder. Alternates offered by the bidder as **EQUAL** to the specifications must be clearly defined. A bidder offering an alternate should attach complete specifications and literature to the bid. The Purchasing Division may waive minor deviations to specifications.
3. Unit prices shall prevail in case of discrepancy. All quotations are considered F.O.B. destination unless alternate shipping terms are clearly identified in the quotation.
4. All quotations must be delivered by the bidder to the office listed below prior to the date and time of the bid opening. Failure of the bidder to deliver the quotations on time will result in bid disqualifications: Department of Administration, Purchasing Division, 2019 Washington Street East, P.O. Box 50130, Charleston, WV 25305-0130
5. Communication during the solicitation, bid, evaluation or award periods, except through the Purchasing Division, is strictly prohibited (W.Va. C.S.R. §148-1-6.6).



State of West Virginia  
 Department of Administration  
 Purchasing Division  
 2019 Washington Street East  
 Post Office Box 50130  
 Charleston, WV 25305-0130

# Request for Quotation

RFQ NUMBER
6612C009

PAGE
2

ADDRESS CORRESPONDENCE TO ATTENTION OF
PAUL REYNOLDS 304-558-0468

RFQ COPY  
 TYPE NAME/ADDRESS HERE

VENDOR

SHIP TO

DIVISION OF HIGHWAYS  
 VARIOUS LOCALES AS INDICATED  
 BY ORDER

DATE PRINTED	TERMS OF SALE	SHIP VIA	F.O.B.	FREIGHT TERMS
11/14/2011				

BID OPENING DATE: 12/07/2011 BID OPENING TIME 01:30PM

LINE	QUANTITY	UOP	CAT. NO.	ITEM NUMBER	UNIT PRICE	AMOUNT
<p>RENEWAL: THIS CONTRACT MAY BE RENEWED UPON THE MUTUAL WRITTEN CONSENT OF THE SPENDING UNIT AND VENDOR, SUBMITTED TO THE DIRECTOR OF PURCHASING THIRTY (30) DAYS PRIOR TO THE EXPIRATION DATE. SUCH RENEWAL SHALL BE IN ACCORDANCE WITH THE TERMS AND CONDITIONS OF THE ORIGINAL CONTRACT AND SHALL BE LIMITED TO TWO (2) SUCCESSIVE ONE (1) YEAR PERIODS.</p> <p>CANCELLATION: THE DIRECTOR OF PURCHASING RESERVES THE RIGHT TO CANCEL THIS CONTRACT IMMEDIATELY UPON WRITTEN NOTICE TO THE VENDOR IF THE COMMODITIES AND/OR SERVICES SUPPLIED ARE OF AN INFERIOR QUALITY OR DO NOT CONFORM WITH THE SPECIFICATIONS OF THE BID AND CONTRACT HEREIN.</p> <p>OPEN MARKET CLAUSE: THE DIRECTOR OF PURCHASING MAY AUTHORIZE A SPENDING UNIT TO PURCHASE ON THE OPEN MARKET, WITHOUT THE FILING OF A REQUISITION OR COST ESTIMATE, ITEMS SPECIFIED ON THIS CONTRACT FOR IMMEDIATE DELIVERY IN EMERGENCIES DUE TO UNFORESEEN CAUSES (INCLUDING BUT NOT LIMITED TO DELAYS IN TRANSPORTATION OR AN UNANTICIPATED INCREASE IN THE VOLUME OF WORK).</p> <p>INSURANCE: SUCCESSFUL VENDOR SHALL FURNISH PROOF OF COVERAGE OF COMMERCIAL GENERAL LIABILITY INSURANCE PRIOR TO ISSUANCE OF THE CONTRACT. UNLESS OTHERWISE SPECIFIED IN THE BID DOCUMENTS, THE MINIMUM AMOUNT OF INSURANCE COVERAGE REQUIRED IS \$250,000.</p> <p>WORKER'S COMPENSATION: VENDOR IS REQUIRED TO PROVIDE A CERTIFICATE FROM WORKER'S COMPENSATION IF SUCCESSFUL.</p> <p>ORDERING PROCEDURE: SPENDING UNIT(S) SHALL ISSUE A WRITTEN STATE CONTRACT ORDER (FORM NUMBER WV-39) TO THE VENDOR FOR COMMODITIES COVERED BY THIS CONTRACT. THE ORIGINAL COPY OF THE WV-39 SHALL BE MAILED TO THE</p>						

SEE REVERSE SIDE FOR TERMS AND CONDITIONS

SIGNATURE	TELEPHONE	DATE
TITLE	FEIN	ADDRESS CHANGES TO BE NOTED ABOVE

WHEN RESPONDING TO RFQ, INSERT NAME AND ADDRESS IN SPACE ABOVE LABELED 'VENDOR'



State of West Virginia  
 Department of Administration  
 Purchasing Division  
 2019 Washington Street East  
 Post Office Box 50130  
 Charleston, WV 25305-0130

# Request for Quotation

RFQ NUMBER  
 6612C009

PAGE  
 3

ADDRESS CORRESPONDENCE TO ATTENTION OF  
 PAUL REYNOLDS  
 304-558-0468

RFQ COPY  
 TYPE NAME/ADDRESS HERE

VENDOR

SHIP TO

DIVISION OF HIGHWAYS  
 VARIOUS LOCALES AS INDICATED  
 BY ORDER

DATE PRINTED	TERMS OF SALE	SHIP VIA	F.O.B.	FREIGHT TERMS
11/14/2011				

BID OPENING DATE: 12/07/2011 BID OPENING TIME 01:30PM

LINE	QUANTITY	UOP	CAT. NO.	ITEM NUMBER	UNIT PRICE	AMOUNT
<p>VENDOR AS AUTHORIZATION FOR SHIPMENT, A SECOND COPY MAILED TO THE PURCHASING DIVISION, AND A THIRD COPY RETAINED BY THE SPENDING UNIT.</p> <p>BANKRUPTCY: IN THE EVENT THE VENDOR/CONTRACTOR FILES FOR BANKRUPTCY PROTECTION, THE STATE MAY DEEM THE CONTRACT NULL AND VOID, AND TERMINATE SUCH CONTRACT WITHOUT FURTHER ORDER.</p> <p>REV. 9/98</p> <p>PREFERENCE FOR USE OF DOMESTIC STEEL PRODUCTS</p> <p>1. EXCEPT WHEN AUTHORIZED BY THE DIRECTOR OF THE PURCHASING DIVISION PURSUANT TO SUBSECTION 2 BELOW, NO CONTRACTOR MAY USE OR SUPPLY STEEL PRODUCTS FOR A STATE CONTRACT PROJECT OTHER THAN THOSE STEEL PRODUCTS MADE IN THE UNITED STATES. AS USED USED IN THIS CONTRACT,</p> <p>A. "STATE CONTRACT PROJECT" MEANS ANY ERECTION OR CONSTRUCTION OF, OR ANY ADDITION TO, ALTERATION OF OR OTHER IMPROVEMENT TO ANY BUILDING OR STRUCTURE, INCLUDING, BUT NOT LIMITED TO, ROADS OR HIGHWAYS, OR THE INSTALLATION OF ANY HEATING OR COOLING OR VENTILATING PLANTS OR OTHER EQUIPMENT, OR THE SUPPLY OF AND MATERIALS FOR SUCH PROJECTS, PURSUANT TO A CONTRACT WITH THE STATE OF WEST VIRGINIA FOR WHICH BIDS WERE SOLICITED ON OR AFTER JUNE 6, 2001.</p> <p>B. "STEEL PRODUCTS" MEANS PRODUCTS ROLLED, FORMED, SHAPED, DRAWN, EXTRUDED, FORGED, CAST, FABRICATED OR OTHERWISE SIMILARLY PROCESSED, OR PROCESSED BY A COMBINATION OF TWO OR MORE OF</p>						

SEE REVERSE SIDE FOR TERMS AND CONDITIONS

SIGNATURE	TELEPHONE	DATE
-----------	-----------	------

TITLE	FEIN	ADDRESS CHANGES TO BE NOTED ABOVE
-------	------	-----------------------------------

WHEN RESPONDING TO RFQ, INSERT NAME AND ADDRESS IN SPACE ABOVE LABELED 'VENDOR'



State of West Virginia  
 Department of Administration  
 Purchasing Division  
 2019 Washington Street East  
 Post Office Box 50130  
 Charleston, WV 25305-0130

# Request for Quotation

RFQ NUMBER
6612C009

PAGE
4

ADDRESS CORRESPONDENCE TO ATTENTION OF
PAUL REYNOLDS 304-558-0468

RFQ COPY

TYPE NAME/ADDRESS HERE

VENDOR

SHIP TO

DIVISION OF HIGHWAYS  
 VARIOUS LOCALES AS INDICATED  
 BY ORDER

DATE PRINTED	TERMS OF SALE	SHIP VIA	F.O.B.	FREIGHT TERMS
11/14/2011				

BID OPENING DATE: 12/07/2011 BID OPENING TIME 01:30PM

LINE	QUANTITY	UOP	CAT NO	ITEM NUMBER	UNIT PRICE	AMOUNT
				<p>SUCH OPERATIONS, FROM STEEL MADE BY THE OPEN HEARTH, BASIC OXYGEN, ELECTRIC FURNACE, BESSEMER OR OTHER STEEL MAKING PROCESS.</p> <p>C. "UNITED STATES" MEANS THE UNITED STATES OF AMERICA AND INCLUDES ALL TERRITORY, CONTINENTAL OR INSULAR, SUBJECT TO THE JURISDICTION OF THE UNITED STATES.</p> <p>2. THE DIRECTOR OF THE PURCHASING DIVISION MAY, IN WRITING, AUTHORIZE THE USE OF FOREIGN STEEL PRODUCTS IF:</p> <p>A. THE COST FOR EACH CONTRACT ITEM USED DOES NOT EXCEED ONE TENTH OF ONE PERCENT (.1%) OF THE TOTAL CONTRACT COST OR TWO THOUSAND FIVE HUNDRED DOLLARS (2,500.00), WHICHEVER IS GREATER. FOR THE PURPOSES OF THIS SECTION, THE COST IS THE VALUE OF THE STEEL PRODUCT AS DELIVERED TO THE PROJECT OR,</p> <p>B. THE DIRECTOR OF THE PURCHASING DIVISION DETERMINES THAT SPECIFIED STEEL MATERIALS ARE NOT PRODUCED IN THE UNITED STATES IN SUFFICIENT QUANTITY OR OTHERWISE ARE NOT REASONABLY AVAILABLE TO MEET CONTRACT REQUIREMENTS.</p> <p>3. A CONTRACTOR WHO USES STEEL PRODUCTS IN VIOLATION OF THIS SECTION MAY BE SUBJECT TO CIVIL PENALTIES PURSUANT TO WV CODE SECTION 5A-3-56.</p> <p>REV. 10/01/01</p> <p style="text-align: center;">NOTICE</p>		

SEE REVERSE SIDE FOR TERMS AND CONDITIONS

SIGNATURE		TELEPHONE	DATE
TITLE	FEIN	ADDRESS CHANGES TO BE NOTED ABOVE	

WHEN RESPONDING TO RFQ, INSERT NAME AND ADDRESS IN SPACE ABOVE LABELED 'VENDOR'



State of West Virginia  
 Department of Administration  
 Purchasing Division  
 2019 Washington Street East  
 Post Office Box 50130  
 Charleston, WV 25305-0130

# Request for Quotation

RFQ NUMBER
6612C009

PAGE
5

ADDRESS CORRESPONDENCE TO ATTENTION OF:
PAUL REYNOLDS 304-558-0468

RFQ COPY

TYPE NAME/ADDRESS HERE

VENDOR

SHIP TO

DIVISION OF HIGHWAYS  
 VARIOUS LOCALES AS INDICATED  
 BY ORDER

DATE PRINTED	TERMS OF SALE	SHIP VIA	F.O.B.	FREIGHT TERMS
11/14/2011				

BID OPENING DATE: 12/07/2011 BID OPENING TIME 01:30PM

LINE	QUANTITY	UOP	CAT. NO.	ITEM NUMBER	UNIT PRICE	AMOUNT
<p>A SIGNED BID MUST BE SUBMITTED TO:</p> <p>DEPARTMENT OF ADMINISTRATION            PURCHASING DIVISION            BUILDING 15            2019 WASHINGTON STREET, EAST            CHARLESTON, WV 25305-0130</p> <p>THE BID SHOULD CONTAIN THIS INFORMATION ON THE FACE OF THE ENVELOPE OR THE BID MAY NOT BE CONSIDERED:</p> <p>SEALED BID</p> <p>BUYER: PAUL REYNOLDS FILE 33</p> <p>RFQ. NO.: 6612C009</p> <p>BID OPENING DATE: 11/30/2011</p> <p>BID OPENING TIME: 01:30 P.M.</p> <p>PLEASE PROVIDE A FAX NUMBER IN CASE IT IS NECESSARY TO CONTACT YOU REGARDING YOUR BID:</p> <p>-----</p> <p>CONTACT PERSON (PLEASE PRINT CLEARLY):</p> <p>-----</p>						

SEE REVERSE SIDE FOR TERMS AND CONDITIONS

SIGNATURE	TELEPHONE	DATE
TITLE	FEIN	ADDRESS CHANGES TO BE NOTED ABOVE

WHEN RESPONDING TO RFQ, INSERT NAME AND ADDRESS IN SPACE ABOVE LABELED 'VENDOR'

## 1. SCOPE OF WORK

The purpose of this contract is to supply all materials for single span truss arch fabric covered steel framed building roof systems to various salt shed building site locations throughout the State of West Virginia.

## 2. DESCRIPTION

The Division of Highways will perform or contract all site preparation and construct the reinforced concrete walls of the building. All materials for the building roof systems shall be delivered to the building site and Division of Highways personnel will perform or contract the installation. The successful bidder must provide a technical expert to the Division of Highways during installation of the roof system; refer to Section 4, Qualifications.

Quantity of one listed on the Bid Schedule, Section 9 and throughout this request is an estimate only. Actual quantities and building site locations will be specified in an Agency Release, which will be issued by the Division of Highways to the awarded vendor at the time delivery is required.

## 3. SPECIFICATIONS

The wall height is twelve feet (12') above finish floor elevation. The minimum wall thickness is twelve inches (12"). The minimum interior clearance required at the apex of the arch shall be as follows:

40' X 70' – 26'  
 55' X 100' – 37'  
 72' X 100' – 39'  
 72' X 140' – 39'  
 72' X 140' – 39' with two doors, one centered on each end

Basic design loads include 90 mph wind load and ground snow load of 35 PSF in addition to the dead and live loads. The load combinations shall be as specified in the applicable building code(s). Reference the WV Code §29-3-5b1 and WV State Fire Commission State Building Code<sup>2</sup>.

Each member must be designed to withstand stresses resulting from combinations of loads that produce maximum allowable stresses in that member. Each assembly shall be properly piece-marked to assist with the identification and erection of the roof system. Piece-marks by secured tagging or welding practices (prior to final coating of assembly) shall be labeled in clear, easily identifiable locations.

Structural steel must comply with The American National Standards Institute (ANSI)/American Institute of Steel Construction (AISC) "Specification for Structural Steel Buildings" (ANSI/AISC 360), latest edition, for design requirements and allowable stresses<sup>3</sup>.

Welded connections must comply with the provisions of the "Specification for Structural Steel Buildings" (ANSI/AISC 360), latest edition<sup>3</sup>.

Vendor sample shop drawings with complete information on the five different proposed systems, from this section and the Bid Schedule, Section 9, must be submitted with the bid. All project specific shop drawings

must be signed and sealed by a Professional Engineer registered in the State of WV. Review and approval of shop drawings will be conducted by the Division of Highways. Bids submitted without sample shop drawings as requested in this section will be disqualified. The shop drawings shall also identify the construction and in-place loads for consideration with the salt shed building design.

The entire system shall be galvanized to resist corrosion from road salt stored within the structure in accordance with the American Society for Testing and Materials (ASTM) "Standard Specification for Zinc (Hot-Dip Galvanized) Coatings on Iron and Steel Products" (ASTM A123)<sup>4</sup>. All fasteners shall be galvanized in accordance with the "Standard Specification for Zinc Coating (Hot-Dip) on Iron and Steel Hardware" (ASTM A153)<sup>4</sup>.

Steel tubing cross members and back wall framing members shall comply with ASTM 500, Grade B, ASTM A501 or ASTM A53 specifications<sup>5</sup>. If vendor is bidding a substitute, an equal to or better than tubing cross members and back wall framing members specifications, vendor shall supply all specifications with bid. Division of Highways will review the proposed substitute, equal to or better than members specifications for adequacy prior to contract award. If the proposed substitute, equal to or better than tubing cross members and back wall framing members specifications do not meet the intended requirements, the bid will be disqualified.

The system is to include hollow structural steel (HSS) end wall steel and fabric on both ends. Back wall shall be totally enclosed and front wall shall include an 18' x 18' roll-up door, centered along front wall, for all sizes. The 72' X 140' shall be bid with an option for two doors, one centered on each end.

Steel connection members shall be fabricated from plate or bar stock and provide 42,000 psi minimum yield strength and comply with ASTM A529, ASTM A570 or ASTM A572 Standards<sup>5</sup>.

Bolts for structural framing shall comply with ASTM A307 or ASTM A325 specifications as necessary for design loads and connection details, including bolts for use in corrosive environments<sup>5</sup>.

The industrial fabric cover system shall be capable of withstanding the design load conditions.

The fabric cover shall be woven high density polyethylene tape with double stack weave – finish coated sides, meeting or exceeding the specs listed below:

Weave	16 x 16 psi woven clear HDPE scrim	
Coating Thickness	4.0 mils average each side (94 g/m <sup>2</sup> )	
Coating Composition	Modified LDPE coating with UV protection	
Weight	12.5 oz/yd <sup>2</sup> (373 g/m <sup>2</sup> )+/-5%	
Thickness	23 mils (0.635mm)	ASTM D5199
Hydrostatic Resistance Method	171 psi (1180 kPa)	ASTM D751A
Grab Tensile	Warp: 340 lbs. (1511 N)	ASTM D5034
	Weft: 340 lbs. (1511 N)	ASTM D5034
Strip Tensile	Warp: 250 lbs. (1112 N)	ASTM D5035
	Weft: 250 lbs. (1112 N)	ASTM D5035
Tongue Tear	Warp: 115 lbs. (511 N)	ASTM D2261
	Weft: 115 lbs. (511 N)	ASTM D2261
Mullen Burst	675 psi (4658 kPa)	ASTM D3786
Cold Crack	Minus 60° C	ASTM D2136



Fire Ratings:	<u>Test/Standard</u>	<u>Flame Spread</u>	<u>Smoke Developed</u>	<u>Char Length</u>
	ASTM E84	FS10	SD 58	6.5
	Can/ULC 5102.2-M88	FS15	SD 125	6.5

The cover fastening system shall be compatible with the specifications above including zero stretch belting, welded fabric pockets and 10,000 pound capacity lashing winches coated to prevent corrosion.

The system shall include aluminum flat bar for fabric termination around entire building.

The color of the fabric cover shall be tan with green trim. Prior to contract award, color samples may be requested by the Division of Highways for review and approval by the Division of Highways.

The warranty period for the industrial cover shall be fifteen (15) years. The awarded vendor shall provide a copy of this warranty.

Permanent fabric repair service shall be included in the bid price. There shall be no separate costs or payment made for repair service. Temporary patching shall only be used when conditions (i.e. temperatures) do not permit permanent repair. Permanent repair shall be made as soon as conditions are appropriate for successful repair.

#### 4. QUALIFICATIONS

- a. The bidder must be currently certified and shall provide a copy of that certification with their bid at a minimum to ISO 9001:2008 Quality Management Systems Standards, having direct experience in the design, manufacture and installation of structures of the type specified herein; shall operate according to a comprehensive quality system<sup>6</sup>.

However, an equivalent or approved substitute current certification of similar Standards shall be considered for approval by the Division of Highways. Documentation of the certification along with a copy of the bidder's current certification shall be provided with bid. Division of Highways will review the equivalent or approved substitute certification prior to contract award.

Whether ISO 9001:2008 certified, equivalent or approved substitute, the certification must continue throughout the term of this contract. Upon any renewals of certification, a copy of the certification must be sent to the Division of Highways.

Bids submitted without complete current certification requirements as requested in this section will be disqualified.

- b. At the time of bid, the bidder shall provide three references with structures in use for at least five (5) years which are a clear span and which enclose an area to or greater than a 72' X 140' concrete structure. Bids submitted without complete reference requirements as requested in this section will be disqualified.

- c. At the time of bid, the bidder shall submit the name and resume of at least one technical expert documenting their experience on at least five (5) jobs or similar type jobs. Bids submitted without complete name and resume requirements as requested in this section will be disqualified. Resumes should be in detail of the expert's experience as if submitting with a job application.
- d. The awarded vendor of this contract for building roof systems shall provide representation at the pre-bid, pre- and post construction meetings for the salt shed projects being constructed for the Division of Highways. This representation shall be to establish coordination, discussion of installation information and any clarification required between the salt shed construction project bidders, awarded contractor(s) or Division of Highways personnel performing the installation on the salt shed building.

## 5. AWARD

The intent of this request is to award to one low bid vendor for all Districts. The award will be based upon supplying an estimated quantity of one each, per item, per District; however, vendors should be cautioned that the quantity of one each is only an estimate and may or may not be purchased by the Division of Highways during the term of this contract. The estimated quantity is for evaluating purposes only. The qualified vendor providing the total lowest bid cost will be awarded the contract.

## 6. DELIVERY

Quantity of one listed on the Bid Schedule, Section 9 is an estimate only. Specific delivery location will be provided at the time of order on an Agency Release to the awarded vendor. Once an Agency Release is issued to the awarded vendor, materials are to be delivered to the location within 30 (thirty) days of the Agency Release unless an alternative delivery schedule has been agreed upon by the awarded vendor and the Division of Highways.

Deliveries shall be made to the designated site during normal project working hours. The awarded vendor shall provide representation to inspect and accept the material on behalf of the Division of Highways. Unloading of material shall be performed by the Division of Highways or the contractor constructing the building.

## 7. VENDOR'S INVOICES

Vendor's invoices must be submitted in original and one copy containing the following:

- a. Division of Highway's Agency Release Number and this Contract Number.
- b. Total quantity and unit price with the total cost of the material furnished.
- c. Roof system authorization number for specific project.

Note: Under no circumstance will the Division of Highways accept, or pay for, quantities of material in excess of the quantity stated on the Agency Release.

## 8. PURCHASING CARD ACCEPTANCE

The State of West Virginia currently utilizes a VISA Purchasing Card Program which is issued through a bank. The successful vendors must accept the State of West Virginia VISA Purchasing Card for payment of all orders placed by any State agency as a condition of award.

### REFERENCES:

<sup>1</sup>[www.legis.state.wv.us/WVCODE/ChapterEntire.cfm?chap=29&art=3&section=5B#03](http://www.legis.state.wv.us/WVCODE/ChapterEntire.cfm?chap=29&art=3&section=5B#03)

<sup>2</sup>[www.firemarshal.wv.gov/Documents/87-04%20State%20Building%20Code.pdf](http://www.firemarshal.wv.gov/Documents/87-04%20State%20Building%20Code.pdf)

<sup>3</sup> [www.aisc.org/store](http://www.aisc.org/store)

<sup>4</sup> [www.astm.org/standards](http://www.astm.org/standards)

<sup>5</sup>[www.astm.org](http://www.astm.org)

<sup>6</sup>[www.iso.org/iso/iso\\_catalogue/catalogue\\_ics/catalogue\\_detail\\_ics.htm?csnumber=46486](http://www.iso.org/iso/iso_catalogue/catalogue_ics/catalogue_detail_ics.htm?csnumber=46486)

9. BID SCHEDULE

6612C009

Building Roof Systems

Vendor: Log Cabin Fence

Delivery: F.O.B. WV Division of Highways Building Site

Quantity of one each, per item, per District.

Each size requested shall include the Complete Roof System.

District	Item 1 - Cost Size - 40' x 70'	Item 2 - Cost Size - 55' x 100'	Item 3 - Cost Size - 72' x 100'	Item 4 - Cost Size - 72' x 140'	Item 5 - Cost Size - 72' x 140' Incl Doors on Both Ends	Contract Total
1	30999 -	67725 -	85345 -	107877 -	110615 -	402561 -
2	30999 -	67725 -	85345 -	107877 -	110615 -	402561 -
3	30999 -	67725 -	85345 -	107877 -	110615 -	402561 -
4	30999 -	67725 -	85345 -	107877 -	110615 -	402561 -
5	30999 -	67725 -	85345 -	107877 -	110615 -	402561 -
6	30999 -	67725 -	85345 -	107877 -	110615 -	402561 -
7	30999 -	67725 -	85345 -	107877 -	110615 -	402561 -
8	30999 -	67725 -	85345 -	107877 -	110615 -	402561 -
9	30999 -	67725 -	85345 -	107877 -	110615 -	402561 -
10	30999 -	67725 -	85345 -	107877 -	110615 -	402561 -
<b>Total Per Item</b>	309990 -	677250 -	853450 -	1,078,770 -	1,106,150 -	

TOTAL \$ 4,025,610 -





**PROJECT SPECIFIC BUILDING INFORMATION**

Building Width	77'-4"
Rafter Centers	14'-1"
Windload (MPH)	90
Snow load (GSL)	24
Windload IF	0.87
Snow load IF	0.8

\*Reactions are in Kips  
 \*\*Windload can act in opposite direction

	A	B	H	V	H	V
1) DL+S.L (BALANCED)H-L	4.474	7.190	-4.374	7.189		
2) DL+S.L (UNBALANCED)H-L	2.878	2.929	-2.878	7.536		
3) DL+0.75WL (POS)+S.L (BALANCED)H-L	-1.512	0.615	-2.832	2.171		
4) DL+0.75WL (NEG)+S.L (BALANCED)H-L	-1.324	1.987	-3.019	3.529		
5) DL+0.75WL (POS)+S.L (UNBALANCED)H-L	-2.711	-2.992	-1.693	2.442		
6) DL+0.75WL (NEG)+S.L (UNBALANCED)H-L	-2.525	-1.237	-1.819	3.797		
7) DL+WL (POS)	-6.363	-6.048	0.571	-4.035		
8) DL+WL (NEG)	-6.117	-4.346	0.326	-2.224		
9) 0.6DL+WL (POS)	-6.498	-6.266	0.666	-4.254		
10) 0.6DL+WL (NEG)	-6.213	-4.463	0.422	-2.443		
11) DL	0.238	0.545	-0.238	0.545		
12) S.L (BALANCED)	4.138	6.428	-4.138	6.427		
13) S.L (UNBALANCED)	2.542	2.164	-2.542	6.776		
14) WL (POS)	-6.601	-6.592	0.809	-4.582		
15) WL (NEG)	-6.356	-4.789	0.564	-2.771		
16) TL	0.098	0.217	-0.098	0.217		

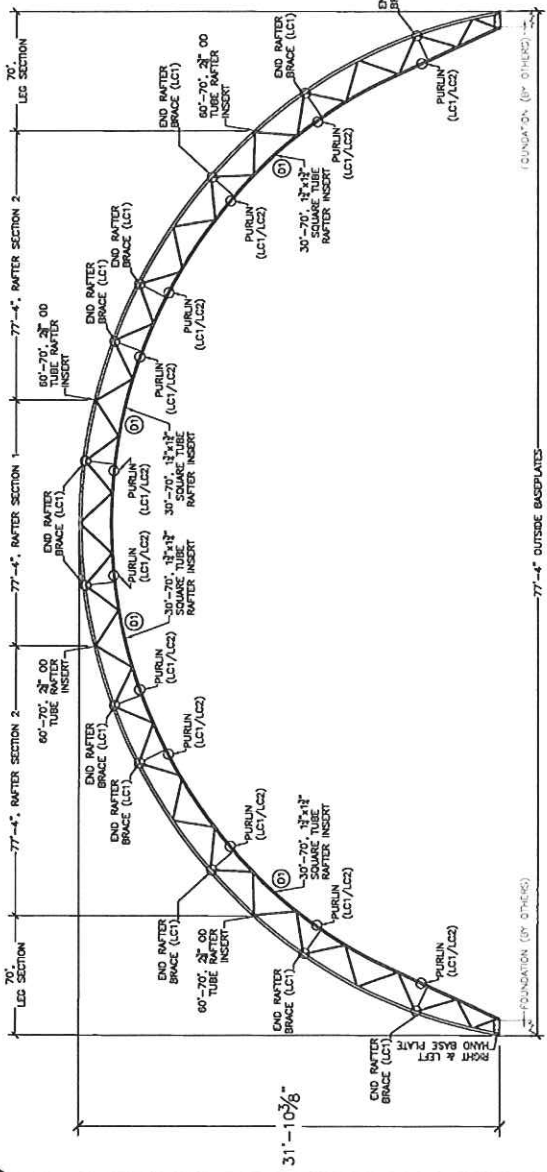

**SECTION VIEW**

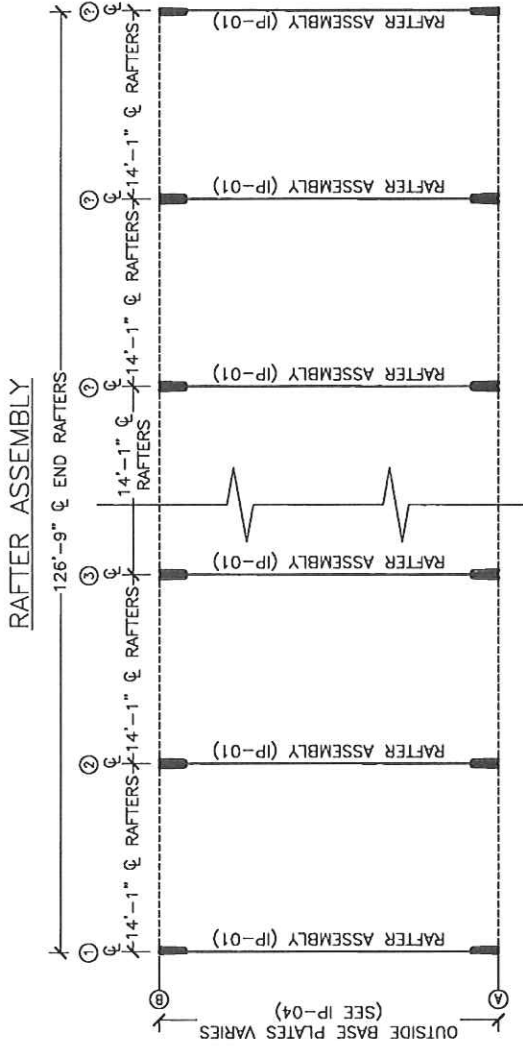

**REACTION NOTES:**

1. THE VERTICAL (V) AND HORIZONTAL (H AND Z) REACTION ARE STATED IN KIPS. (1 KIP = 1000 POUNDS) POSITIVE DIRECTION IS AS SHOWN IN THE FOLLOWING DIAGRAM.
2. MOMENT REACTIONS ARE STATED IN INCH-KIPS AND ARE POSITIVE IN A COUNTERCLOCKWISE DIRECTION.
3. THE FORCE ON THE ANCHOR BOLTS OR FOUNDATION WILL BE IN THE OPPOSITE DIRECTION TO THAT SHOWN.
4. MAXIMUM REACTION SUMMARY IS THE MAXIMUM POSITIVE AND NEGATIVE REACTIONS BASED ON THE REQUIRED LOAD COMBINATIONS.
5. THE WIND LOAD BRACING REACTIONS DO NOT INCLUDE EWP, EWS AND IP REACTIONS FROM THE INTERMEDIATE FRAME. THESE REACTIONS SHOULD BE ADDED TO GET THE TOTAL REACTIONS FOR THE FOUNDATION DESIGN.

**7423 Hollow Ridge Dr.**  
**Nangia P.E.**  
**Houston, TX 77095**

REGISTERED PROFESSIONAL ENGINEER  
 STATE OF TEXAS  
 NO. 7046  
 CHANDLER P. NANGIA

THIS DRAWING WAS  
 PRODUCED BY AND/OR  
 SUPERVISION OF  
 NANGIA P.E.  
 UNDER THE DIRECT  
 SUPERVISION OF  
 NANGIA P.E.

Project Name:	SALT STORAGE BUILDING
Client:	GRAND MIDLAND
Building Description:	174'x128'±
Address:	P.O. BOX 201
City:	20187 SHAW
State:	TX 75087
Phone:	1-866-987-2534
Fax:	1-866-987-2534
Website:	www.ams-engineering.com
Project No.:	110202011
Drawn By:	JOB
Checked By:	
Job Number:	
Sheet Number:	
Design Number:	

**IP-01**





# 77'-4" BUILDING CABLE LAYOUT

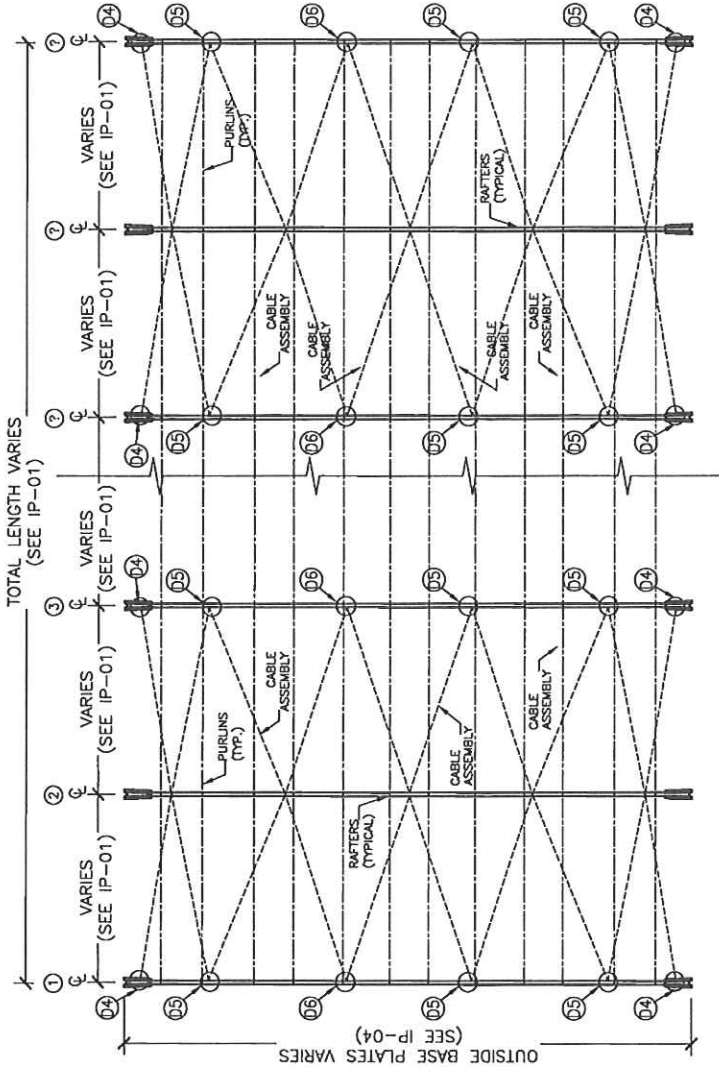

**REGISTERED PROFESSIONAL ENGINEER**  
**CHANDLER P. NANGIA**  
 NO. 7046  
 STATE OF TEXAS  
 REGISTERED PROFESSIONAL ENGINEER  
 THIS DRAWING WAS  
 PRODUCED BY AND/OR  
 SUPERVISED BY  
 NANGIA P.E.  
 7423 Hollow Ridge Dr.  
 Houston, TX 77095

**NOTE: ALL CABLES TO GO OVER TOP OF PURLINS AND THRU RAFTERS**

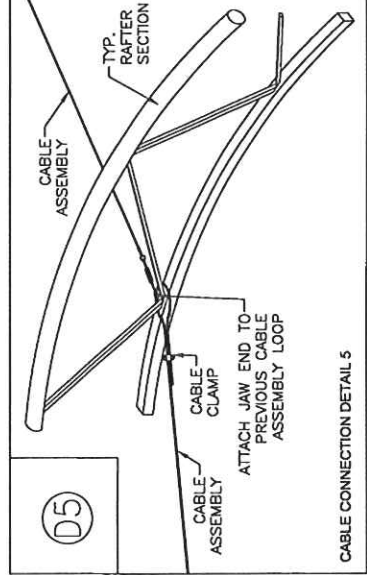
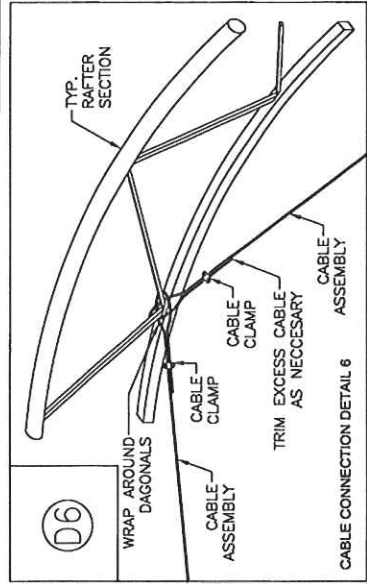
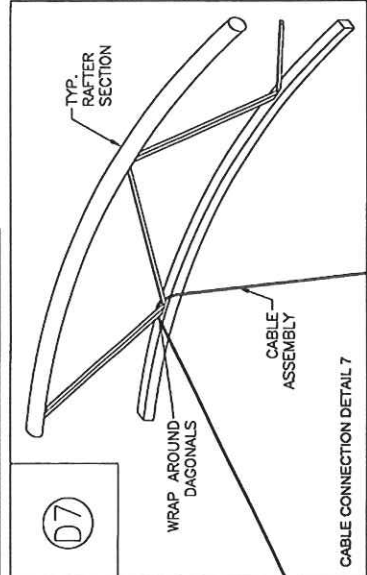
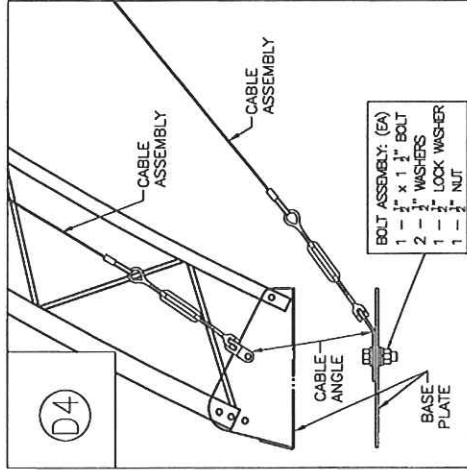

Project Name:	S&T STORAGE BUILDING
Project Location:	RAUBEN COUNTY, WY
Building Description:	77'-4" x 128'-9"
Date:	08/20/2011
Drawn by:	JCH
Checked by:	
Scale:	AS SHOWN
30 MPH EXP. C. WIND	

**IP-02**

THIS DOCUMENT CONTAINS INFORMATION PROPRIETARY TO ACQUASTEL INC. IT SHALL NOT BE REPRODUCED, USED, OR DISCLOSED WITHOUT PERMISSION OF ACQUASTEL INC.

Rev.	Desc.	Author	Check	Date







MAIN COVER WALL MOUNT LAYOUT

**NOTE: DUCT TAPE ALL RAFTER JOINTS AND ANY ROUGH SURFACES BEFORE PULLING COVERS. DO NOT LEAVE ANY EXPOSED, SHARP POINTS OR COVER MAY GET DAMAGED DURING OR AFTER INSTALLATION.**

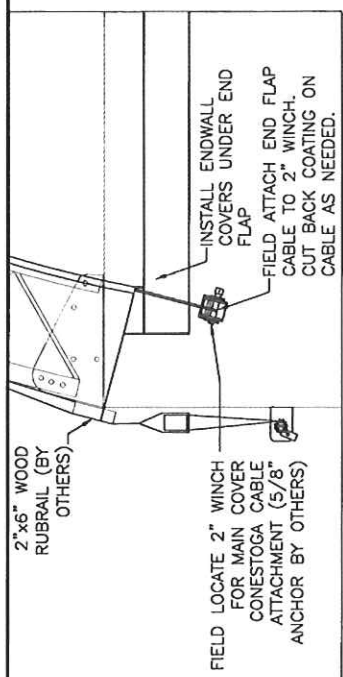

END FLAP DETAIL

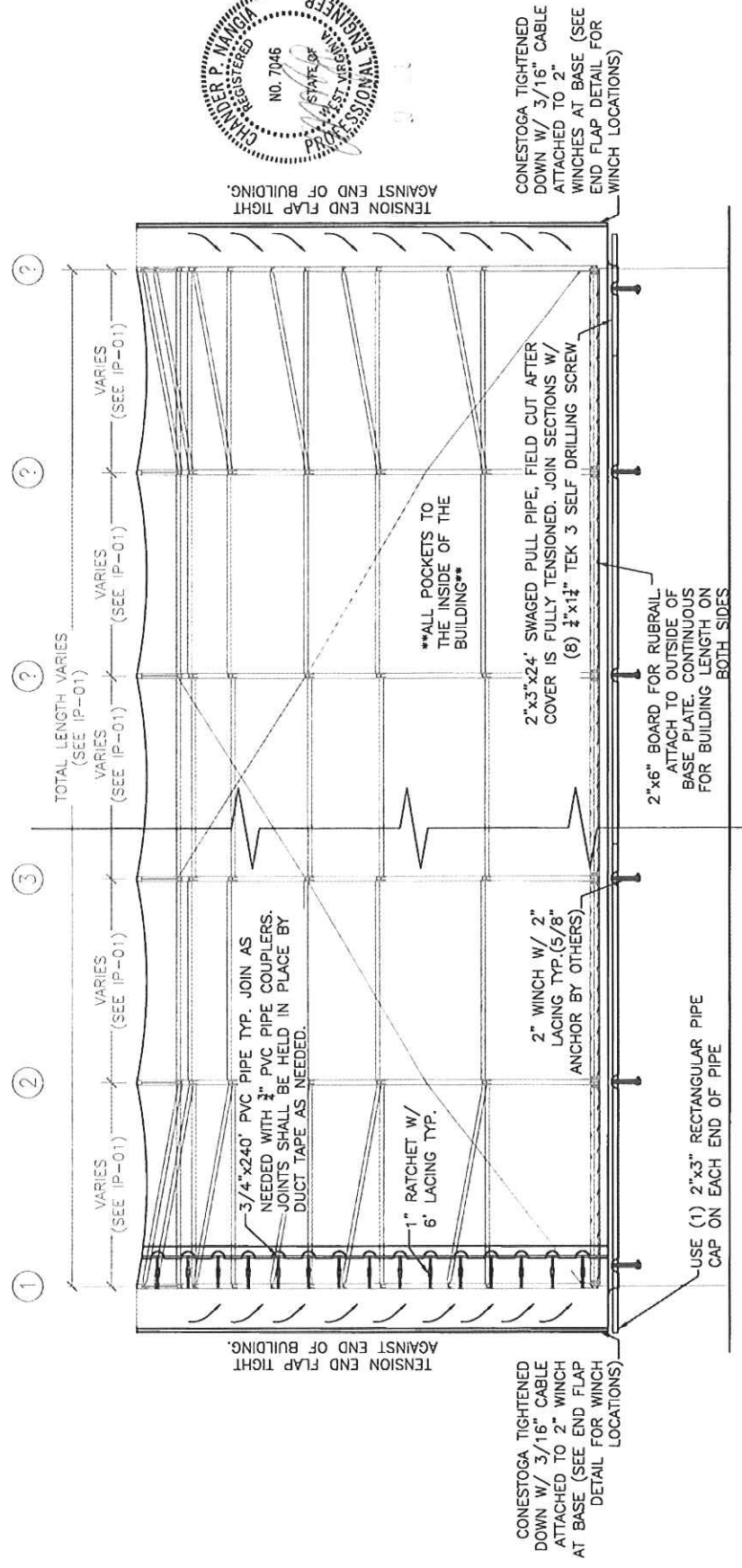

<p>THIS DOCUMENT CONTAINS INFORMATION PROPRIETARY TO ACU-STEEL INC. IT SHALL NOT BE REPRODUCED, USED OR DISCLOSED WITHOUT PERMISSION OF ACU-STEEL INC.</p>	<p><b>ADVANTAGE</b> 1-866-987-2534 P O BOX 201 TEMPLETON, IA 51463</p>	<p>Project Name: SAT STORAGE BUILDING Project Location: RALEIGH COUNTY, WV Client: RALEIGH COUNTY, WV Building Designer: 17-4-128-4 Date: 01/02/2011 Drawn By: JCH Checked By: JCH</p>	<p><b>CP-01W</b></p>
--	--	--	----------------------

FRONT ENDWALL MFG REQUIRED

CALL OUT	PART NAME(# PER END)	TOTAL ORDERED	ORDER LENGTH	FIELD CUT
41010012-316	C1 316" 8X4 ENDWALL COLUMN	2	-	YES
#1010007-312BH1	312" 8X4 ENDWALL HEADER BOTTOM	1	-	YES
43190000-220	G1 220" 4X4 ENDWALL GIRT	2	-	YES
41010071	4" ENDWALL GIRT/RAFTER CLIP	2	-	YES
49070000	4"-8" ENDWALL COLUMN/RAFTER CLIP	2	-	YES
31190000	ENDWALL CONNECTOR	4	-	YES
31010030	FLUSH MOUNT GIRT CLIP	4	-	YES
-	77"-4" ENDWALL COVER	1	-	YES
43510000	3X3 VENT CLIP	6	-	YES
41360000	2X3 RUBRAIL INSERT	2	-	YES
41325000	FINISH ANGLE	3	20'-0"	YES
41010027	2"x3"-24" PRE-GALV. PULL PIPE	4	-	YES

Nengla P.E.  
7423 Hollow Ridge Dr.  
Houston, TX 77095

REGISTERED PROFESSIONAL ENGINEER  
NO. 7046  
STATE OF TEXAS  
PROFESSIONAL ENGINEERING

THIS DRAWING WAS PRODUCED BY AN ARCHITECT UNDER THE DIRECT SUPERVISION OF NENGLA P.E.

FRONT ENDWALL FASTENERS REQUIRED

CALL OUT	PART NAME(# PER END)	TOTAL ORDERED	ORDER LENGTH	FIELD CUT
23050000	A325 1/2x1-1/2	14	+4	YES
23110000	A325 1/2x3	14	-	YES
23130000	A325 1/2x4	6	-	YES
23140000	A307 1/2x5-1/2	32	-	YES
25005000	A325 1/2 FW	132	-	YES
25015000	A325 1/2 LW	66	-	YES
24015000	A325 1/2 NUTS	66	-	YES
27070000	TEK W/ WASHER 1/4x1-1/4	252	-	YES
31580000	1/4x2 FENDER WASHER	18	-	YES
31585000	3/4" PVC PIPE SCH 80	6	-	YES
31595000	3/4" PVC PIPE COUPLER	5	-	NO
36235000	1" RATCHET W/ LACING	110	-	YES
31540000	2" WINCH RIGHT HAND SINGLE HOLE 2" LACING	6	-	YES
27255000	5/8"x8" WEDGE ANCHORS GALV.	6	-	YES
27200000	1/2"x7" WEDGE ANCHORS GALV.	6	-	YES
-	CANARM 12,000 CFM EXHAUST FAN	1	-	YES

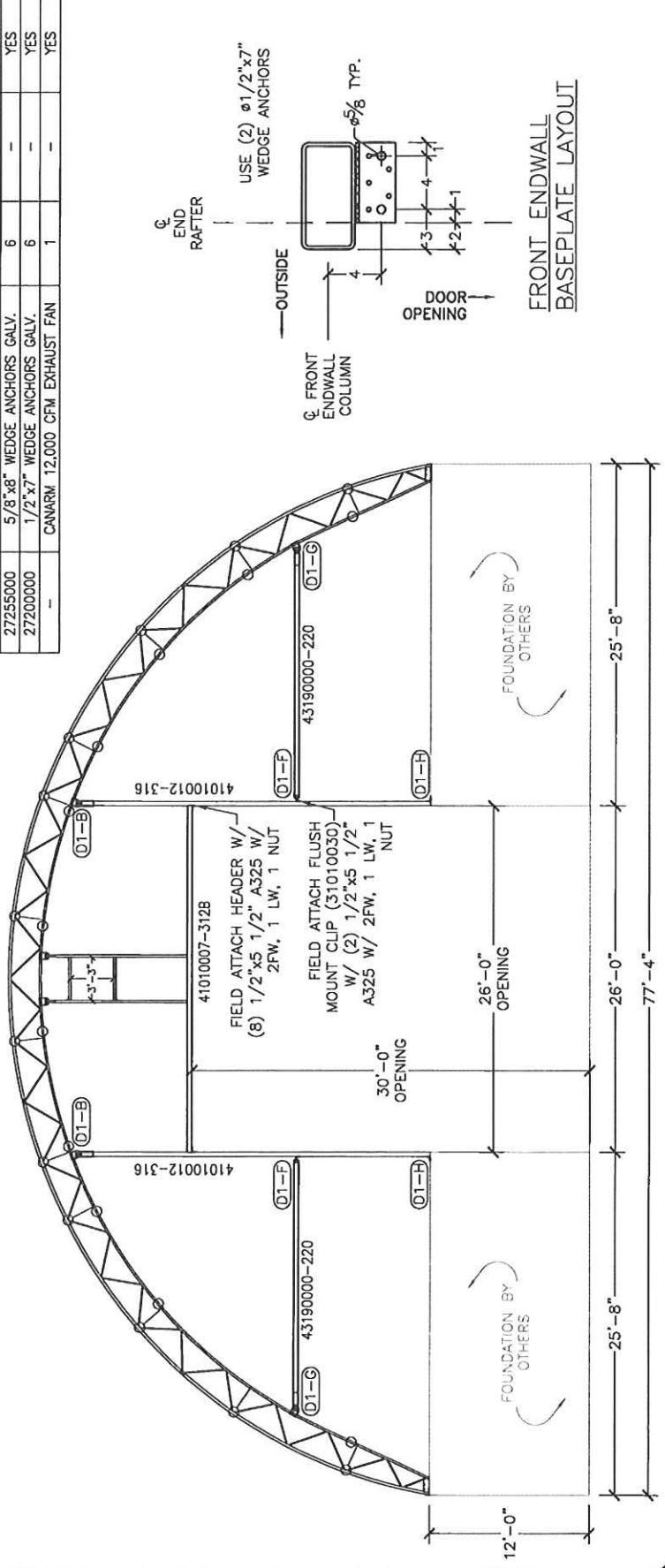

FRONT ENDWALL LAYOUT

THIS DOCUMENT CONTAINS INFORMATION PROPRIETARY TO ACCU-STEEL, INC. IT IS NOT BE REPRODUCED, USED, OR DISCLOSED WITHOUT PRIOR WRITTEN PERMISSION OF ACCU-STEEL, INC.

**ADVANTAGE**  
STRUCTURES  
1-866-897-2534  
TEMPLETON, LA 71463  
800-331-1233

Project Name: 5411 STIGLICE BUILDING  
Project Location: GREENHURST, VA  
Building Description: 77'-4"x125'-9"  
Building Design Code & Loads: ASCE 7-10  
Date: 01/02/2011  
Drawn By: JCH  
Checked By: JCH  
Date: 01/02/2011  
IP-77A









CRANE REQUIREMENTS

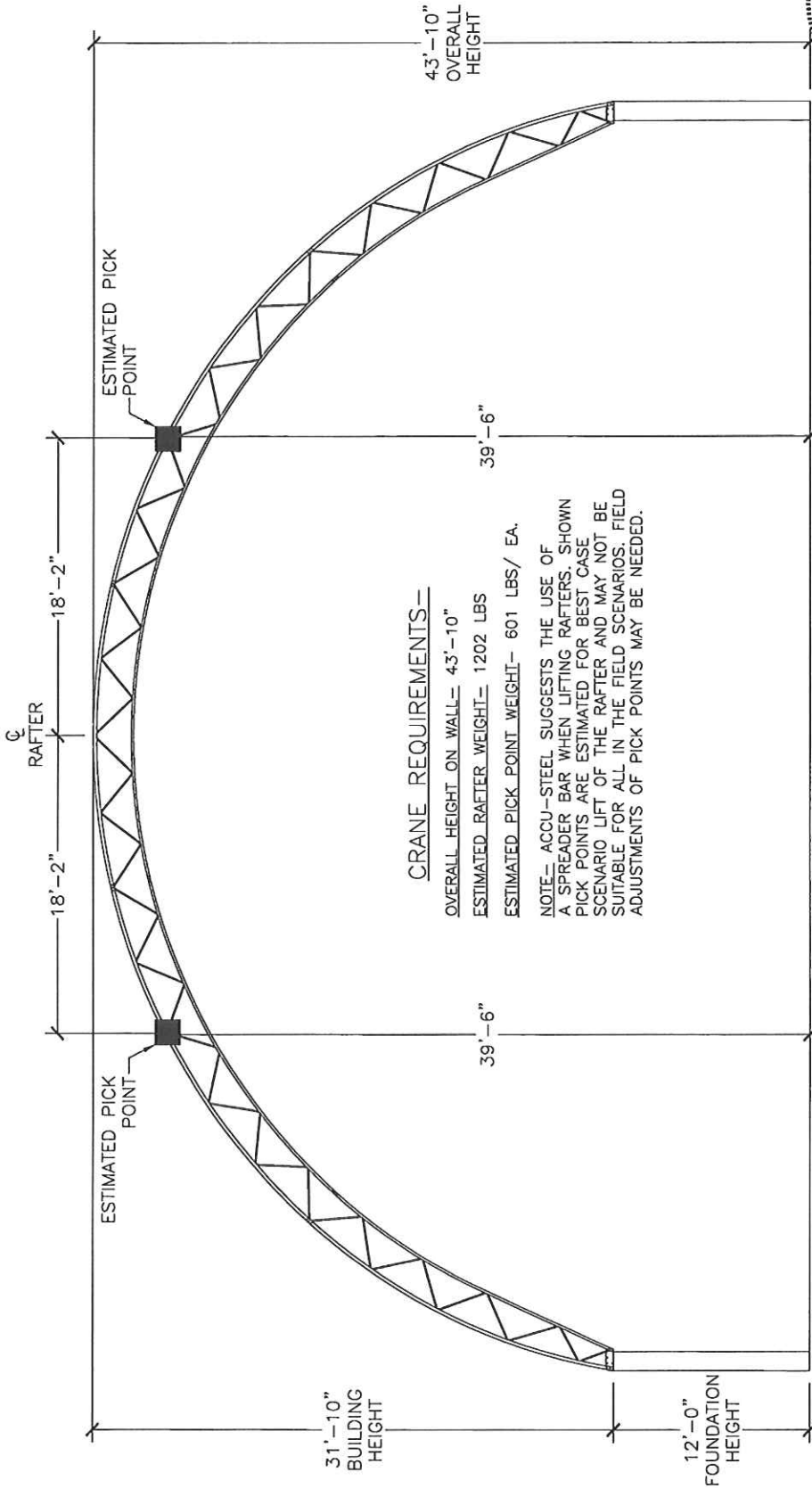

CHANDLER P. MAINS  
 REGISTERED PROFESSIONAL ENGINEER  
 NO. 7046  
 WEST VIRGINIA  
 PROFESSIONAL ENGINEERING BOARD

IP-PP



1-866-987-2534  
 P.O. BOX 201  
 TEMPLETON, PA 19383

Rev.	Date	Description

THIS DOCUMENT CONTAINS INFORMATION PROPRIETARY TO ACCU-STEEL INC. IT SHALL NOT BE REPRODUCED, USED, OR DISCLOSED WITHOUT PRIOR WRITTEN PERMISSION OF ACCU-STEEL INC.

State of West Virginia

VENDOR PREFERENCE CERTIFICATE

Certification and application\* is hereby made for Preference in accordance with West Virginia Code, §5A-3-37. (Does not apply to construction contracts). West Virginia Code, §5A-3-37, provides an opportunity for qualifying vendors to request (at the time of bid) preference for their residency status. Such preference is an evaluation method only and will be applied only to the cost bid in accordance with the West Virginia Code. This certificate for application is to be used to request such preference. The Purchasing Division will make the determination of the Resident Vendor Preference, if applicable.

- 1. Application is made for 2.5% resident vendor preference for the reason checked: Bidder is an individual resident vendor and has resided continuously in West Virginia for four (4) years immediately preceding the date of this certification; or, Bidder is a partnership, association or corporation resident vendor and has maintained its headquarters or principal place of business continuously in West Virginia for four (4) years immediately preceding the date of this certification; or 80% of the ownership interest of Bidder is held by another individual, partnership, association or corporation resident vendor who has maintained its headquarters or principal place of business continuously in West Virginia for four (4) years immediately preceding the date of this certification; or, Bidder is a nonresident vendor which has an affiliate or subsidiary which employs a minimum of one hundred state residents and which has maintained its headquarters or principal place of business within West Virginia continuously for the four (4) years immediately preceding the date of this certification; or,

- 2. Application is made for 2.5% resident vendor preference for the reason checked: Bidder is a resident vendor who certifies that, during the life of the contract, on average at least 75% of the employees working on the project being bid are residents of West Virginia who have resided in the state continuously for the two years immediately preceding submission of this bid; or,

- 3. Application is made for 2.5% resident vendor preference for the reason checked: Bidder is a nonresident vendor employing a minimum of one hundred state residents or is a nonresident vendor with an affiliate or subsidiary which maintains its headquarters or principal place of business within West Virginia employing a minimum of one hundred state residents who certifies that, during the life of the contract, on average at least 75% of the employees or Bidder's affiliate's or subsidiary's employees are residents of West Virginia who have resided in the state continuously for the two years immediately preceding submission of this bid; or,

- 4. Application is made for 5% resident vendor preference for the reason checked: Bidder meets either the requirement of both subdivisions (1) and (2) or subdivision (1) and (3) as stated above; or,

- 5. Application is made for 3.5% resident vendor preference who is a veteran for the reason checked: Bidder is an individual resident vendor who is a veteran of the United States armed forces, the reserves or the National Guard and has resided in West Virginia continuously for the four years immediately preceding the date on which the bid is submitted; or,

- 6. Application is made for 3.5% resident vendor preference who is a veteran for the reason checked: Bidder is a resident vendor who is a veteran of the United States armed forces, the reserves or the National Guard, if, for purposes of producing or distributing the commodities or completing the project which is the subject of the vendor's bid and continuously over the entire term of the project, on average at least seventy-five percent of the vendor's employees are residents of West Virginia who have resided in the state continuously for the two immediately preceding years.

Bidder understands if the Secretary of Revenue determines that a Bidder receiving preference has failed to continue to meet the requirements for such preference, the Secretary may order the Director of Purchasing to: (a) reject the bid; or (b) assess a penalty against such Bidder in an amount not to exceed 5% of the bid amount and that such penalty will be paid to the contracting agency or deducted from any unpaid balance on the contract or purchase order.

By submission of this certificate, Bidder agrees to disclose any reasonably requested information to the Purchasing Division and authorizes the Department of Revenue to disclose to the Director of Purchasing appropriate information verifying that Bidder has paid the required business taxes, provided that such information does not contain the amounts of taxes paid nor any other information deemed by the Tax Commissioner to be confidential.

Under penalty of law for false swearing (West Virginia Code, §61-5-3), Bidder hereby certifies that this certificate is true and accurate in all respects; and that if a contract is issued to Bidder and if anything contained within this certificate changes during the term of the contract, Bidder will notify the Purchasing Division in writing immediately.

Bidder: \_\_\_\_\_ Signed: \_\_\_\_\_

Date: \_\_\_\_\_ Title: \_\_\_\_\_

\*Check any combination of preference consideration(s) indicated above, which you are entitled to receive.



## Log Cabin Fence

411 Ten Mile Rd  
Amity, PA 15311

T 724-222-8755  
F 724-222-2510

[www.LogCabinFence.com](http://www.LogCabinFence.com)

December 2, 2011

Department of Administration  
Purchasing Division  
Building 15  
2019 Washington Street, East  
Charleston, WV 25305-0130

To whom it may concern:

Attached is the bid packet for RFQ 6612C009. Buildings quoted are manufactured by Accu Steel Building solutions from Templeton, IA. All buildings include engineered to 35 psf snow and 90 mph wind sealed drawings. Each cover is tan with green trim HL-13 fabrene.

Please note the sealed engineering drawings are not entirely included as we have those prepared on a case by case basis and the cost to provide for bid purposes is cost prohibitive. As an example of our capability and prints we offer, we have included a set of prints we recently provided to the West Virginia Parkways Authority. We would be happy to provide a similar set of prints for all buildings related to this bid. Please also feel free to contact Ron Hamilton, Director of Engineering and Maintenance at 304-256-6680.

Please note we currently are not ISO 9001:2008 certified; however, our references and track record indicate a display a proven history of the highest possible quality structures and installation.

Please see below for our list of references for buildings in use for at least 5 years:

Bruce Braun  
City of Des Moines  
Public Works Department  
216 SE 5th St  
Des Moines, IA 50309  
515-237-1371  
\*84x160 Salt Storage Building

Bret Hodne  
City of West Des Moines  
560 S 16th St  
West Des Moines, IA 50265  
515-222-3480  
\*84x220 Salt Storage Building

\*Continued on next page

Greg Felt  
Scott County, MN  
Operations Manager  
600 County Trail East  
Jordan, MN 55352  
952-496-8047  
\*120x140 Salt Storage Building

Jason Kress  
State of Nebraska  
5001 S 14th St PO Box 94759  
Lincoln, NE 68509  
402-479-3746  
\*Contract for Multiple years, building sizes, and locations

Also, the primary construction supervisor for these projects would be Jim Iams. He has been with Log Cabin Fence since 1981 and installing hoop structures since 1996. Jim is the primary contact on the majority of our larger projects including ten structures for Waste Management, two structures for Cleveland Brothers Caterpillar, and numerous other single build, unique install projects.

If there are any questions I can answer for you please do not hesitate to contact me.

Sincerely yours,

A handwritten signature in cursive script that reads "Clint W Iams".

Clint Iams

RFQ No. 6612C009

STATE OF WEST VIRGINIA  
Purchasing Division

**PURCHASING AFFIDAVIT**

West Virginia Code §5A-3-10a states: No contract or renewal of any contract may be awarded by the state or any of its political subdivisions to any vendor or prospective vendor when the vendor or prospective vendor or a related party to the vendor or prospective vendor is a debtor and the debt owned is an amount greater than one thousand dollars in the aggregate

**DEFINITIONS:**

"Debt" means any assessment, premium, penalty, fine, tax or other amount of money owed to the state or any of its political subdivisions because of a judgment, fine, permit violation, license assessment, defaulted workers' compensation premium, penalty or other assessment presently delinquent or due and required to be paid to the state or any of its political subdivisions, including any interest or additional penalties accrued thereon.

"Debtor" means any individual, corporation, partnership, association, Limited Liability Company or any other form or business association owing a debt to the state or any of its political subdivisions. "Political subdivision" means any county commission; municipality; county board of education; any instrumentality established by a county or municipality; any separate corporation or instrumentality established by one or more counties or municipalities, as permitted by law; or any public body charged by law with the performance of a government function or whose jurisdiction is coextensive with one or more counties or municipalities. "Related party" means a party, whether an individual, corporation, partnership, association, limited liability company or any other form or business association or other entity whatsoever, related to any vendor by blood, marriage, ownership or contract through which the party has a relationship of ownership or other interest with the vendor so that the party will actually or by effect receive or control a portion of the benefit, profit or other consideration from performance of a vendor contract with the party receiving an amount that meets or exceeds five percent of the total contract amount.

**EXCEPTION:** The prohibition of this section does not apply where a vendor has contested any tax administered pursuant to chapter eleven of this code, workers' compensation premium, permit fee or environmental fee or assessment and the matter has not become final or where the vendor has entered into a payment plan or agreement and the vendor is not in default of any of the provisions of such plan or agreement.

Under penalty of law for false swearing (*West Virginia Code §61-5-3*), it is hereby certified that the vendor affirms and acknowledges the information in this affidavit and is in compliance with the requirements as stated.

**WITNESS THE FOLLOWING SIGNATURE**

Vendor's Name: LOG CABIN FENCE CO. INC

Authorized Signature: Clint W. Fox Date: 12/2/11

State of PENNSYLVANIA

County of WASHINGTON, to-wit:

Taken, subscribed, and sworn to before me this 2<sup>nd</sup> day of DECEMBER 20 11

My Commission expires 3-14-15, 20     

AFFIX SEAL HERE

NOTARY PUBLIC

David R. Fox

COMMONWEALTH OF PENNSYLVANIA

NOTARIAL SEAL

DAVID R. FOX, Notary Public

Waynesburg Boro, Greene County

My Commission Expires March 14, 2015

Purchasing Affidavit (Revised 12/15/09)