



State of West Virginia  
 Department of Administration  
 Purchasing Division  
 2019 Washington Street East  
 Post Office Box 50130  
 Charleston, WV 25305-0130

# Request for Quotation

RFQ NUMBER  
**061200262**

PAGE  
**1**

ADDRESS CORRESPONDENCE TO ATTENTION OF:  
**ALAN CUMMINGS**  
**304-558-2402**

VENDOR

\*709015618      800-824-6166  
**L B FOSTER COMPANY**  
**3493 LANSLOWNE DR STE 1**  
  
**LEXINGTON KY 40517**

SHIP TO

**DIVISION OF HIGHWAYS**  
**DISTRICT SIX**  
**1 DOT DRIVE**  
  
**MOUNDSVILLE, WV**  
**26041**      **304-843-3656**

DATE PRINTED <b>04/10/2012</b>	TERMS OF SALE <i>Net 30 Days</i>	SHIP VIA <i>Truck</i>	F.O.B. <i>SP/IFA</i>	FREIGHT TERMS <i>Delivered</i>
BID OPENING DATE: <b>04/25/2012</b>		BID OPENING TIME <b>01:30PM</b>		

LINE	QUANTITY	UOP	CAT NO.	ITEM NUMBER	UNIT PRICE	AMOUNT
0001	1	LS		400-15	<i>Lump Sum</i>	<i>42,488.46</i>
ALUMINUM BRIDGE RAILING						
<p>THE WEST VIRGINIA STATE PURCHASING DIVISION FOR THE AGENCY, THE WEST VIRGINIA DIVISION OF HIGHWAYS, IS SOLICITING BIDS TO PROVIDE THE AGENCY WITH THE REPLACEMENT OF ALUMINUM BRIDGE RAILING ON THE BENWOOD BRIDGE PER THE ATTACHED SPECIFICATIONS.</p> <p>CANCELLATION: THE DIRECTOR OF PURCHASING RESERVES THE RIGHT TO CANCEL THIS CONTRACT IMMEDIATELY UPON WRITTEN NOTICE TO THE VENDOR IF THE COMMODITIES AND/OR SERVICES SUPPLIED ARE OF AN INFERIOR QUALITY OR DO NOT CONFORM TO THE SPECIFICATIONS OF THE BID AND CONTRACT HEREIN.</p> <p>BANKRUPTCY: IN THE EVENT THE VENDOR/CONTRACTOR FILES FOR BANKRUPTCY PROTECTION, THE STATE MAY DEEM THE CONTRACT NULL AND VOID, AND TERMINATE SUCH CONTRACT WITHOUT FURTHER ORDER.</p> <p>PURCHASING CARD ACCEPTANCE: THE STATE OF WEST VIRGINIA CURRENTLY UTILIZES A VISA PURCHASING CARD PROGRAM WHICH IS ISSUED THROUGH A BANK. THE SUCCESSFUL VENDOR MUST ACCEPT THE STATE OF WEST VIRGINIA VISA PURCHASING CARD FOR PAYMENT OF ALL ORDERS PLACED BY ANY STATE AGENCY AS A CONDITION OF AWARD.</p> <p style="text-align: center;">NOTICE</p> <p>A SIGNED BID MUST BE SUBMITTED TO:</p>						
						<p><b>RECEIVED</b></p> <p><b>2012 APR 24 AM 9:55</b></p> <p><b>WV PURCHASING DIVISION</b></p>

SEE REVERSE SIDE FOR TERMS AND CONDITIONS

SIGNATURE <i>Joseph Wolf</i>	TELEPHONE <b>800-824-6166</b>	DATE <b>4/23/12</b>
TITLE <b>District Sales Mgr</b>	FEIN <b>25-1324733</b>	ADDRESS CHANGES TO BE NOTED ABOVE

WHEN RESPONDING TO RFQ, INSERT NAME AND ADDRESS IN SPACE ABOVE LABELED 'VENDOR'

## GENERAL TERMS & CONDITIONS REQUEST FOR QUOTATION (RFQ) AND REQUEST FOR PROPOSAL (RFP)

1. Awards will be made in the best interest of the State of West Virginia.
2. The State may accept or reject in part, or in whole, any bid.
3. Prior to any award, the apparent successful vendor must be properly registered with the Purchasing Division and have paid the required \$125 fee.
4. All services performed or goods delivered under State Purchase Order/Contracts are to be continued for the term of the Purchase Order/Contracts, contingent upon funds being appropriated by the Legislature or otherwise being made available. In the event funds are not appropriated or otherwise available for these services or goods this Purchase Order/Contract becomes void and of no effect after June 30.
5. Payment may only be made after the delivery and acceptance of goods or services.
6. Interest may be paid for late payment in accordance with the *West Virginia Code*.
7. Vendor preference will be granted upon written request in accordance with the *West Virginia Code*.
8. The State of West Virginia is exempt from federal and state taxes and will not pay or reimburse such taxes.
9. The Director of Purchasing may cancel any Purchase Order/Contract upon 30 days written notice to the seller.
10. The laws of the State of West Virginia and the *Legislative Rules* of the Purchasing Division shall govern the purchasing process.
11. Any reference to automatic renewal is hereby deleted. The Contract may be renewed only upon mutual written agreement of the parties.
12. **BANKRUPTCY:** In the event the vendor/contractor files for bankruptcy protection, the State may deem this contract null and void, and terminate such contract without further order.
13. **HIPAA BUSINESS ASSOCIATE ADDENDUM:** The West Virginia State Government HIPAA Business Associate Addendum (BAA), approved by the Attorney General, is available online at [www.state.wv.us/admin/purchase/vrc/hipaa.html](http://www.state.wv.us/admin/purchase/vrc/hipaa.html) and is hereby made part of the agreement provided that the Agency meets the definition of a Cover Entity (45 CFR §160.103) and will be disclosing Protected Health Information (45 CFR §160.103) to the vendor.
14. **CONFIDENTIALITY:** The vendor agrees that he or she will not disclose to anyone, directly or indirectly, any such personally identifiable information or other confidential information gained from the agency, unless the individual who is the subject of the information consents to the disclosure in writing or the disclosure is made pursuant to the agency's policies, procedures, and rules. Vendor further agrees to comply with the Confidentiality Policies and Information Security Accountability Requirements, set forth in <http://www.state.wv.us/admin/purchase/privacy/noticeConfidentiality.pdf>.
15. **LICENSING:** Vendors must be licensed and in good standing in accordance with any and all state and local laws and requirements by any state or local agency of West Virginia, including, but not limited to, the West Virginia Secretary of State's Office, the West Virginia Tax Department, and the West Virginia Insurance Commission. The vendor must provide all necessary releases to obtain information to enable the director or spending unit to verify that the vendor is licensed and in good standing with the above entities.
16. **ANTITRUST:** In submitting a bid to any agency for the State of West Virginia, the bidder offers and agrees that if the bid is accepted the bidder will convey, sell, assign or transfer to the State of West Virginia all rights, title and interest in and to all causes of action it may now or hereafter acquire under the antitrust laws of the United States and the State of West Virginia for price fixing and/or unreasonable restraints of trade relating to the particular commodities or services purchased or acquired by the State of West Virginia. Such assignment shall be made and become effective at the time the purchasing agency tenders the initial payment to the bidder.

I certify that this bid is made without prior understanding, agreement, or connection with any corporation, firm, limited liability company, partnership, or person or entity submitting a bid for the same material, supplies, equipment or services and is in all respects fair and without collusion or Fraud. I further certify that I am authorized to sign the certification on behalf of the bidder or this bid.

---

### INSTRUCTIONS TO BIDDERS

1. Use the quotation forms provided by the Purchasing Division. Complete all sections of the quotation form.
2. Items offered must be in compliance with the specifications. Any deviation from the specifications must be clearly indicated by the bidder. Alternates offered by the bidder as **EQUAL** to the specifications must be clearly defined. A bidder offering an alternate should attach complete specifications and literature to the bid. The Purchasing Division may waive minor deviations to specifications.
3. Unit prices shall prevail in case of discrepancy. All quotations are considered F.O.B. destination unless alternate shipping terms are clearly identified in the quotation.
4. All quotations must be delivered by the bidder to the office listed below prior to the date and time of the bid opening. Failure of the bidder to deliver the quotations on time will result in bid disqualifications: Department of Administration, Purchasing Division, 2019 Washington Street East, P.O. Box 50130, Charleston, WV 25305-0130
5. Communication during the solicitation, bid, evaluation or award periods, except through the Purchasing Division, is strictly prohibited (W.Va. C.S.R. §148-1-6.6).





State of West Virginia  
 Department of Administration  
 Purchasing Division  
 2019 Washington Street East  
 Post Office Box 50130  
 Charleston, WV 25305-0130

# Request for Quotation

RFQ NUMBER
061200262

PAGE
2

ADDRESS CORRESPONDENCE TO ATTENTION OF:
ALAN CUMMINGS 304-558-2402

VENDOR	*709015618	800-824-6166
	L B FOSTER COMPANY	
	3493 LANSDOWNE DR STE 1	
	LEXINGTON KY 40517	

SHIP TO	DIVISION OF HIGHWAYS
	DISTRICT SIX
	1 DOT DRIVE
	MOUNDSVILLE, WV 26041
	304-843-3656

DATE PRINTED	TERMS OF SALE	SHIP VIA	F.O.B.	FREIGHT TERMS
04/10/2012	Net 30 days	TRUCK	SP/FA	TRUCK
BID OPENING DATE: 04/25/2012		BID OPENING TIME 01:30PM		

LINE	QUANTITY	UOP	CAT NO	ITEM NUMBER	UNIT PRICE	AMOUNT
DEPARTMENT OF ADMINISTRATION PURCHASING DIVISION BUILDING 15 2019 WASHINGTON STREET, EAST CHARLESTON, WV 25305-0130						
THE BID SHOULD CONTAIN THIS INFORMATION ON THE FACE OF THE ENVELOPE OR THE BID MAY NOT BE CONSIDERED:  SEALED BID  BUYER: ALAN CUMMINGS - FILE 33  RFQ. NO.: 061200262  BID OPENING DATE: 04/25/2012  BID OPENING TIME: 1:30 P.M.  PLEASE PROVIDE A FAX NUMBER IN CASE IT IS NECESSARY TO CONTACT YOU REGARDING YOUR BID:  ----- 859-245-1768 -----  CONTACT PERSON (PLEASE PRINT CLEARLY):  ----- Joe Deyesso -----  ANY INDIVIDUAL SIGNING THIS BID IS CERTIFYING THAT:						

SEE REVERSE SIDE FOR TERMS AND CONDITIONS			
SIGNATURE <i>[Signature]</i>	TELEPHONE 800-824-6166	DATE 4/23/12	
TITLE District Sales Mgr.	FEIN 25-1324733	ADDRESS CHANGES TO BE NOTED ABOVE	

WHEN RESPONDING TO RFQ, INSERT NAME AND ADDRESS IN SPACE ABOVE LABELED 'VENDOR'



State of West Virginia  
 Department of Administration  
 Purchasing Division  
 2019 Washington Street East  
 Post Office Box 50130  
 Charleston, WV 25305-0130

# Request for Quotation

RFQ NUMBER  
**061200262**

PAGE  
**3**

ADDRESS CORRESPONDENCE TO ATTENTION OF:  
**ALAN CUMMINGS**  
**304-558-2402**

VENDOR

\*709015618      800-824-6166  
**L B FOSTER COMPANY**  
**3493 LANSDOWNE DR STE 1**  
  
**LEXINGTON KY 40517**

SHIP TO

**DIVISION OF HIGHWAYS**  
**DISTRICT SIX**  
**1 DOT DRIVE**  
  
**MOUNDSVILLE, WV**  
**26041**                      **304-843-3656**

DATE PRINTED	TERMS OF SALE	SHIP VIA	F.O.B.	FREIGHT TERMS
04/10/2012	<i>Net 30 days</i>	<i>Truck</i>	<i>SPIFA</i>	<i>Delivered</i>

BID OPENING DATE: **04/25/2012**                      BID OPENING TIME **01:30PM**

LINE	QUANTITY	UOP	CAT NO.	ITEM NUMBER	UNIT PRICE	AMOUNT
(1) HE OR SHE IS AUTHORIZED BY THE BIDDER TO EXECUTE THE BID OR ANY DOCUMENTS RELATED THERETO ON BEHALF OF THE BIDDER, (2) THAT HE OR SHE IS AUTHORIZED TO BIND THE BIDDER IN A CONTRACTUAL RELATIONSHIP, AND (3) THAT THE BIDDER HAS PROPERLY REGISTERED WITH ANY STATE AGENCIES THAT MAY REQUIRE REGISTRATION.						
***** THIS IS THE END OF RFQ 061200262 ***** TOTAL:						<i>\$ 42,488.46</i>

SEE REVERSE SIDE FOR TERMS AND CONDITIONS

SIGNATURE <i>Joseph Hill</i>	TELEPHONE <i>800-824-6166</i>	DATE <i>4/23/12</i>
TITLE <i>District Sales Mgr</i>	FEIN <i>25-1324733</i>	ADDRESS CHANGES TO BE NOTED ABOVE

WHEN RESPONDING TO RFQ, INSERT NAME AND ADDRESS IN SPACE ABOVE LABELED 'VENDOR'



**RFQ#: 061200262**

## **Specifications**

Purpose: To replace aluminum bridge railing on the Benwood Bridge caused by three (3) accidents.

### **1.0 DEFINITIONS**

- A. The "Agency" shall be defined as the West Virginia Division of Highways
- B. The "Vendor" shall be defined as the successful bidder.
- C. The "Purchase Order" shall be defined as the binding agreement that is entered into between the State of West Virginia and the Vendor to provide the services as herein specified.
- D. "Mandatory Requirements: The terms "must", "will", "shall", "minimum", "maximum", or "is/are required" identify a mandatory item or factor. Decisions regarding compliance with any mandatory requirements shall be at the sole discretion of the State.

### **2.0 SCOPE OF WORK**

The successful Vendor shall provide materials for the railing on the Benwood Bridge caused by three (3) accidents.

- 2.1 Technical Requirements: Medal thickness (gauge) 5/16"  
Post size: diameter and height—wf 6" x 6" x 5.5 alum 2' x 1 1/2"  
Aluminum shall be in accordance with ASTM B 221 alloy 6061-T6 OR 6062-T6.

#### 2.1.1 Claim Number—CR1889R

Top Rail-3-1/8" x 4" Rectangular, Aluminum

Bottom Rail-3-3/4" x 4-3/4" Rectangular, Aluminum

- a. Top Rail-straight: 8' 7" welded end caps on both ends
- b. Bottom Rail-straight: 8' 7" welded end caps on both ends
- c. Top Rail-straight: 10' welded end cap on one end
- d. Aluminum clamp bars for top rail, hardware included
- e. Aluminum camp bars for bottom rail, hardware included
- f. Fabricated Aluminum Posts
- g. Aluminum Spice sleeves for top rail

\*  
\$ 14,183.03

## 2.1.2 Claim Number- Cm1771R

- a. Top Rail 5' radius: 12' welded end cap on one end
- b. Bottom Rail 5' radius: 12' welded end cap on one end
- c. Aluminum splice sleeve for top rail
- d. Aluminum splice sleeve for bottom rail
- e. Aluminum Clamp Bars for Top Rail hardware included
- d. Aluminum Clamp Bars for Bottom Rail hardware included
- g. Fabricated Aluminum Post

\*  
\$ 17,415.48

## 2.1.3 Claim Number-B26A080

- a. Top Rail 5' radius: 9' weld end caps on both ends
- b. Aluminum clamp bars for top rail, hardware included
- c. Aluminum clamp bars for bottom rail, hardware included
- d. Fabricated Aluminum Post

\*  
\$ 10,889.95

## 2.1.4 Notes

- a. All Aluminum is Mill Finished
- b. Pricing is only valid for lump sum shipment of all three (3) accident claims

2.2 Freight: will be FOB destination

2.3 Delivery shall be made to the WVDOT:

West Virginia Division of Highways

1 Dot Drive Building 3

Moundsville, WV 26041

Attn: Dave Sada

### 3.0 INVOICING

#### 3.1 Payment

3.1 The Vendor must send an invoice to:

West Virginia Division of Highways

1 Dot Drive Building 3

Moundsville, WV 26041

Attention: Harold Logsdon

3.2 Invoices will be paid with State Visa Card

#### **4.0 AWARD**

Purchase Order will be awarded to the lowest responsible bidder meeting the specifications listed. Purchase Order will be awarded complete and not split.

#### **709.12-STRUCTURAL AND EYEBAR STEEL:**

All structural steel for bridges shall conform to the applicable grade of AASHTO M270 that is specified in the Plans. When no specific grade for, AASHTO M270, Grade 36 shall be used. Non-designated structural steel in all other section of the Specifications shall conform to ASTM A36.

## Cost Sheet

Item Number	ESTIMATED QUANTITY	UNIT OF MEASURE	Description	Unit Price	EXTENDED Amount
1	1	EACH	TOP RAIL 3 1/8" X 4" RECTANGULAR ALUMINUM		\$ N/A
2	1	EACH	BOTTOM RAIL 3 3/4" X 4 3/4" RECTANGULAR ALUMINUM		\$
3	1	EACH	TOP RAIL STRIAIGHT 8'-7" WELDED END CAPS ON BOTH ENDS		\$
4	1	EACH	BOTTOM RAIL STRAIGHT 8'-7" WELDED END CAPS ON BOTH ENDS		\$
5	1	EACH	TOP RAIL STRAIGHT 10'-0" WELDED END CAP ON ONE END		\$
6	1	EACH	TOP RAIL 5' RADIOUS: 12'-0" WELDED END CAP ON ONE END		\$
7	1	EACH	BOTTOM RAIL 5' RADIOUS: 9'-0" WELDED END CAPS ON ONE END		\$
8	1	EACH	TOP RAIL 5' RADIOUS: 9'-0" WELDED END CAPS ON BOTH ENDS		\$
9	16	EACH	ALUMINUM CLAMP BARS FOR TOP RAIL, HARDWARE INCLUDED		\$
10	14	EACH	ALUMINUM CLAMP BARS FOR BOTTOM RAIL, HARDWARE INCLUDED		\$
11	5	EACH	FABRICATED ALUMINUM POSTS		\$
12	3	EACH	ALUMINUM SPLICE SLEEVES FOR TOP RAIL		\$
13	1	EACH	ALUMINUM SPLICE SLEEVES FOR BOTTOM RAIL		\$
			ALL ALUMINUM IS MILL FINISH		
			TOTAL COST		\$ 42,488.46



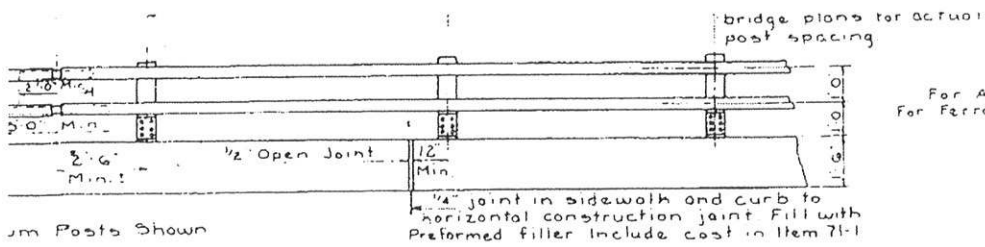

ALUMINUM & FERROUS METAL BRIDGE RAILING  
Scale: 3/8" = 1'-0"

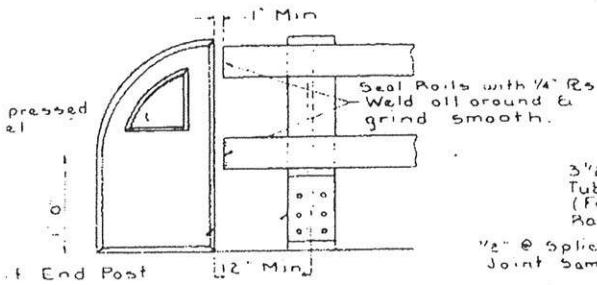
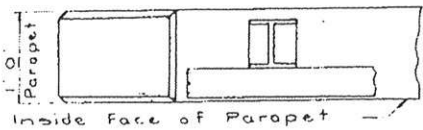

TERMINATION OF RAILING DETAILS  
Scale: 1" = 1'-0"

6 x 6 x 5.5 # Alum - W

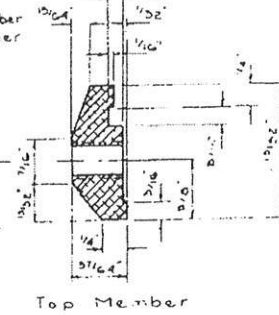
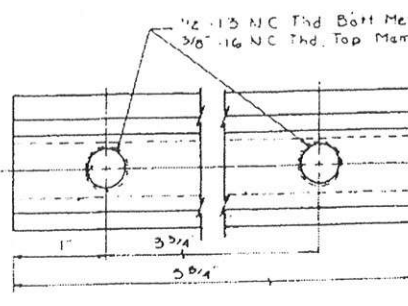
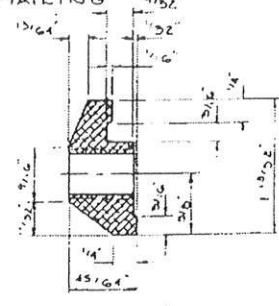
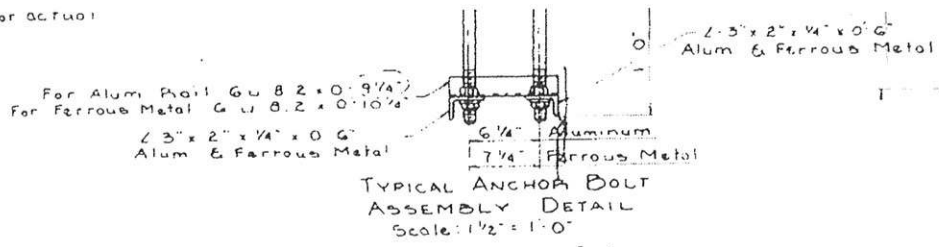
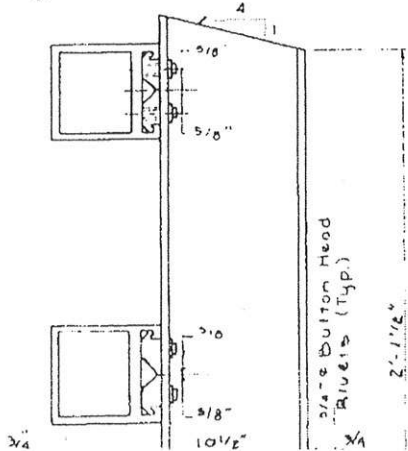

CLAMP BAR DETAILS

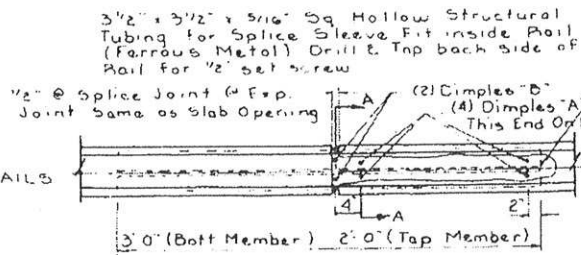

SPLICE DETAIL  
Scale: 1/2" = 1'-0"

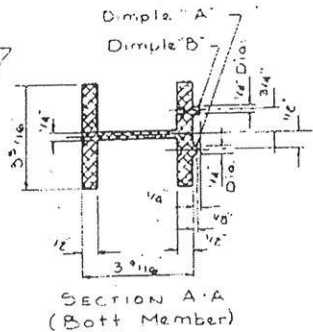

SECTION A-A  
(Bottom Member)

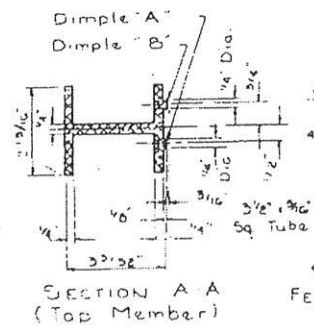

SECTION A-A  
(Top Member)

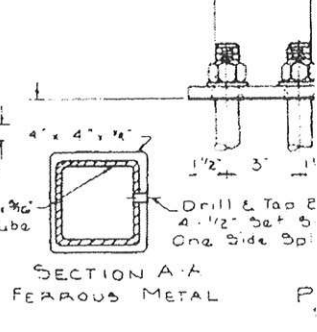

SECTION A-A  
FERROUS METAL

Note - Aluminum Railing:  
Posts, rails and base plates shall be extruded shapes as detailed, in accordance with ASTM B-221, alloy 6061-T6 or 6062-T6.  
All rivets and set screws shall be ASTM B-221 or B-211 alloy 6061 T-6 temper.  
Weld filler wire shall be ASTM B-205, alloy ER-5556.  
Anchor bolts, washers, nuts and assembly shall be of same material and finish as ferrous metal.  
End closure for rails shall be a 1/4" plate fitted to the inside of the tubing, welded all around with an 1/8" weld and ground smooth.  
Rails on curved sections shall be bent to the correct radius in the shop.  
Anchor bolts to be cast in place.  
Posts shall be set normal to grade unless otherwise noted on the plans.  
Cost of anchor bolts, railing, rail posts, hardware, and elastomeric pads shall be included in the price bid for Item 71-4 Aluminum Railing, per linear foot.  
No painting of posts and railing is required.  
All sharp edges shall be rounded.

Art 31714 - Elastomeric Bearing Pads for Bridge Railing Posts:  
(A) General: These specifications cover an elastomeric bearing pad used for bridge railing posts. The thickness shall be as designated on plans. It shall be cast in molds under pressure and heat. The samples for test shall be prepared according to ASTM Tentative Method D-15. The pad shall meet the following requirements:  
(B) Physical Requirements:  
(1) Tensile Strength ASTM D412 (PSI) 2500+  
(2) Durometer hardness ASTM D676 70 ± 5  
(3) Compression set ASTM D395 (22 hrs @ 150 °F) (Percent) 25-  
(4) Change in Durometer hardness, heat aged 70 hrs @ 212 °F 15-

Note:  
Assemb  
Al  
nuts ar  
A.  
Al  
with or  
to be 1/4  
for each  
Al  
drilling  
zinc coc  
M11160  
A.  
to be galv  
Al  
galvaniz  
Pr  
Er  
inside o  
ground  
B  
correct  
A  
Pr  
wise no  
C  
and sta  
bid for  
N  
A



Quote #: **BDOL00WTPN-5**



Construction Products

To: **West Virginia Dept. of Transportation**

One DOT Drive  
 Building 3  
 Moundsville, WV 26041

Attention: Harold Logsdon

**Mailing Address:**

L. B. Foster Company  
 3493 Lansdowne Drive  
 Suite 1  
 Lexington, KY 40517

**Phone:** (800) 824-6166

**Mobile:** (617) 320-1463

**Fax:** (859) 245-1768

**Date:** 04/23/2012

**Re: Moundsville District**

Aluminum Railing Repair Material  
 Foster Quote# 1218-10,

**Shipping Location:** Moundsville, WV

We are pleased to offer the following items, material only, excluding field measurements, installation and taxes for the referenced project.

<u>Qty.</u>	<u>Description</u>	<u>Price / UOM</u>	<u>Extended Price</u>
1.00 LS	<p><b>Included in this quotation are the following items:</b></p> <p>Top Rail - 3-1/8" x 4" rectangular, aluminum                      Bottom Rail - 3-3/4" x 4-3/4" rectangular, aluminum</p> <p><b>Claim # CR1889R</b></p> <ul style="list-style-type: none"> <li>- 1 top rail straight: 8'-7", welded end caps on both ends</li> <li>- 1 bottom rail straight: 8'-7", welded end caps on both ends</li> <li>- 1 top rail straight: 10'-0", welded end cap on one end</li> <li>- 8 aluminum clamp bars for top rail, hardware included</li> <li>- 6 aluminum clamp bars for bottom rail, hardware included</li> <li>- 2 fabricated aluminum posts</li> <li>- 2 aluminum splice sleeves for top rail</li> </ul>	\$14,183.0264/ LS	\$14,183.03
1.00 EA	<p><b>Claim # CM1771R</b></p> <ul style="list-style-type: none"> <li>- 1 top rail 5' radius: 12'-0", welded end cap on one end (our shop will determine if the rail is to be bent or mitered.)</li> <li>- 4 aluminum clamp bars for top rail, hardware included</li> <li>- 4 aluminum clamp bars for bottom rail, hardware included</li> <li>- 2 fabricated aluminum posts</li> <li>- 1 aluminum splice sleeve for top rail</li> <li>- 1 aluminum splice sleeve for bottom rail</li> </ul>	\$17,415.4773/ EA	\$17,415.48



Quote #: BDOL00WTPN-5

**LBFoster**

Construction Products

**To: West Virginia Dept. of Transportation**One DOT Drive  
Building 3  
Moundsville, WV 26041**Attention:** Harold Logsdon**Mailing Address:**L. B. Foster Company  
3493 Lansdowne Drive  
Suite 1  
Lexington, KY 40517**Phone:** (800) 824-6166**Mobile:** (617) 320-1463**Fax:** (859) 245-1768**Date:** 04/23/2012**Re: Moundsville District**Aluminum Railing Repair Material  
Foster Quote# 1218-10,**Shipping Location:** Moundsville, WV

<u>Qty.</u>	<u>Description</u>	<u>Price / UOM</u>	<u>Extended Price</u>
1.00 EA	Claim # B26A080 - 1 top rail 5' radius: 9'-0" welded end caps on both ends (our shop will determine if the rail is to be bent or mitered.) - 1 top rail 5' radius: 9'-0" welded end caps on both ends (our shop will determine if the rail is to be bent or mitered.) - 4 aluminum clamp bars for top rail, hardware included - 4 aluminum clamp bars for bottom rail, hardware included - 1 fabricated aluminum post	\$10,889.9547 / EA	\$10,889.95

- NOTES:**
- 1. All aluminum is mill finish**
  - 2. Pricing is only valid for lump sum shipment of all 3 accident claims.**
  - 3. Delivery: 12-14 weeks after receipt of Approved LBF cover drawing and Bill of Material.**
  - 4. Prices are based on minimum mill quantities of 1,000 # of material for each of the rail and splice sizes.**

\$ 42,488.46

**FOB:** Shipping point, freight allowed to job site, full truckload basis only.  
**Terms:** Net 30 with Credit Approval.  
**Shipment:** Shipment may begin approximately 12-14 weeks after receipt of approval shop drawings. Shop drawings will be submitted for approval 3-4 weeks after receipt of order.

Quote #: BDOL00WTPN-5

# LB Foster

Construction Products

**Mailing Address:**  
L. B. Foster Company  
3493 Lansdowne Drive  
Suite 1  
Lexington, KY 40517

**To: West Virginia Dept. of Transportation**  
One DOT Drive  
Building 3  
Moundsville, WV 26041

**Phone:** (800) 824-6166  
**Mobile:** (617) 320-1463  
**Fax:** (859) 245-1768  
**Date:** 04/23/2012

**Attention:** Harold Logsdon

**Re: Moundsville District**  
Aluminum Railing Repair Material  
Foster Quote# 1218-10,

**Shipping Location:** Moundsville, WV

Submitted by: LB Foster Company - Fabricated Bridge Products:

  
\_\_\_\_\_  
Joseph Deyesso, District Sales Manager

Acceptance: The above proposal, including all documents incorporated therein, shall constitute a Contract when executed by each party below, or when Buyer gives L. B. Foster Company written notice to proceed, whichever occurs first.

BUYER: \_\_\_\_\_  
BY: \_\_\_\_\_  
TITLE: \_\_\_\_\_  
DATE: \_\_\_\_\_

LB Foster Company -  
BY: \_\_\_\_\_  
TITLE: \_\_\_\_\_  
DATE: \_\_\_\_\_



## TERMS AND CONDITIONS

1. **Delays** — Seller shall not be responsible for any failure or delay in delivery due to fires, floods, labor troubles, whether or not due to fault of the Seller, breakdowns, delay of carriers, mill delay, total or partial failure for any reason of the usual sources of supply or transportation, requirements or request of any government or subdivision thereof, or any similar or dissimilar cause beyond the Seller's direct control.
2. **Payments and Credit** — Shipments, deliveries and performance of work shall at all times be subject to the approval of the Seller's credit department. Invoices submitted by Seller under this order are payable at par in legal tender of the United States of America in the city designated in the remittance address, upon the payment terms and in the amounts set forth hereon. Discount is applicable only to the amount shown on the face of the invoice as "Discount Amount". Whenever reasonable grounds for insecurity should arise with respect to due performance by the Buyer, Seller may demand different terms of payment from those specified on the face of this order and may demand satisfactory security for the performance of Buyer obligation. Any such demand shall be in writing and Seller may, upon making such demand, suspend shipments hereunder. If, within the period stated in such demand, Buyer fails or refuses to agree to such different terms of payment, or fails or refuses to give adequate security for due performance, Seller may at its option treat such failure or refusal as a repudiation of a portion of order which has not been fully performed or may resume shipments under reservation of possession or of a security interest and may demand payment against tender of documents of title. AS LIQUIDATED DAMAGES AND NOT AS A PENALTY BUYER SHALL BE OBLIGATED TO PAY ON ALL ACCOUNTS NOT PAID ON THE DUE DATE THEREOF, THE LOWER OF (I) 1 1/2% PER MONTH ON THE OUTSTANDING ACCOUNT BALANCE OR (II) THE HIGHEST RATE PERMITTED BY LAW TOGETHER WITH ALL ATTORNEY'S FEES INCURRED BY SELLER TO COLLECT ANY DELINQUENT ACCOUNTS. Buyer agrees that notwithstanding any endorsements or legend appearing on Buyer's checks, drafts or other orders for payment of money they do not, solely because of such endorsement of legend or otherwise, constitute payment in full or settlement of the account. No failure of the Seller to exercise any right accruing from any default of the Buyer shall impair Seller's right in case of any subsequent default of the Buyer.
3. **Progress Billings** -- Seller may make progress billings for costs incurred in an equitable amount reasonably determined by Seller.
4. **Standard Tolerances** -- Except in particulars specified by the Buyer expressly agreed to in writing by Seller, the materials furnished hereunder are produced in accordance with standard manufacturing practices at the country of origin. All materials are subject to mill tolerances and variations consistent with normal manufacturing practice with respect to dimension, weight, straightness, section, composition and mechanical properties, normal variations in surface and internal conditions and in quality, to deviations in tolerances and variations consistent with practical testing and inspection methods and to regular mill practices of Seller's suppliers of over and under shipments. The Seller is not responsible for any deterioration in quality, which may result from processing operations or improper use by the Buyer. Except to the extent inconsistent with other provisions of this offer, material and workmanship shall be in accordance with the standard specifications of the American Institute of Steel Construction, latest edition.
5. **Changes** — Orders or specifications may not be canceled or changed except upon terms that will indemnify the Seller against all loss. Postponement of delivery at Buyer's request, if for a period of more than thirty days, will not be made without Seller's approval first being obtained. Seller assumes no responsibility for any changes in specifications unless such changes are confirmed in writing by Buyer and accepted in writing by Seller. Any price variation resulting from such changes shall become effective immediately upon the acceptance of such changes.
6. **Inspection** — Where Buyer is to inspect, inspection and acceptance must be made before shipment.
7. **Warranty and Limitation of Remedies** — Upon receipt of definite shipping instructions from Seller, Buyer shall return all defective material to Seller after inspection by Seller, or at Seller's election, subject to inspection by Seller's representative. The material returned must be returned in the same condition as when received by the Buyer. As Buyer's exclusive remedy, defective material so returned shall be replaced or repaired by the Seller without an additional charge or, in lieu of such replacement or repair, Seller may at its option, refund the purchase price applicable to such material. Seller agrees to pay return transportation charges not exceeding those which would apply from original destination on all defective material or material not meeting specification. However, Seller shall not be obligated for such charges when material returned proves to be free from defect and to meet specifications. Material, which proves to be free from defect and to meet specifications, shall be held by Seller for shipping instructions. Buyer shall furnish such instructions promptly upon request. SELLER'S LIABILITY SHALL BE LIMITED SOLELY TO REPLACEMENT OR REPAIR, OR, AT SELLER'S OPTION TO REFUNDING THE PURCHASE PRICE APPLICABLE TO DEFECTIVE MATERIAL OR MATERIAL NOT MEETING SPECIFICATIONS. SELLER SHALL IN NO EVENT BE LIABLE FOR ANY CONSEQUENTIAL OR INCIDENTAL DAMAGES OR FOR LOSS, DAMAGES OR EXPENSES DIRECTLY OR INDIRECTLY ARISING FROM THE USE OF THE MATERIAL INCLUDING, WITHOUT LIMITATION, WAREHOUSING, LABOR HANDLING AND SERVICE CHARGES NOT EXPRESSLY AUTHORIZED BY SELLER. THIS WARRANTY IS IN LIEU AND EXCLUDES ALL OTHER WARRANTIES GUARANTEES OR REPRESENTATIONS, EXPRESS OR IMPLIED, BY OPERATION OF LAW OR OTHERWISE, INCLUDING ANY WARRANTY OF MERCHANTABILITY OR FITNESS FOR A PARTICULAR PURPOSE. SELLER SHALL HAVE NO LIABILITY ARISING FROM DESIGN FURNISHED BY OTHERS OR FROM ARCHITECT'S ERRORS OR OMISSIONS.
8. **Taxes** — All taxes of any sort now or hereafter imposed by any federal, state, municipal or other governmental agency that may be levied against this transaction at any time now or in the future are for the Buyer's account.
9. **Source of Materials** — Unless otherwise expressly agreed upon, Seller has the right to obtain the material ordered from any source at its discretion.
10. **Conflicting Provisions** — Objection is hereby made to any additional or conflicting provisions in any of Buyer's documents. Any alteration to the provisions of this offer must be approved in writing by Seller.
11. **Delivery Date** — The scheduled delivery date(s) shall be mutually determined upon final drawing approval.
12. **Errors** — Clerical or mathematical errors contained herein may be corrected any time by Seller.
13. **Patents** — If any material shall be sold by Seller to meet Buyer's specifications or requirements and is not a part of Seller's standard line offered by it to the trade generally in the usual course of Seller's business, Buyer agrees to defend, protect and save harmless Seller against all suits at law or in equity and from all damage, claims and demands for actual or alleged infringement of any United States or foreign patent and to defend any suits or action which may be brought against Seller for any alleged infringement because of the sale of any such material.
14. **Waivers** — No waivers by the Seller of any breach of any provisions hereof shall constitute a waiver of any other breach of such provision. Seller's failure to object to provisions contained in any communication from the Buyer shall not be deemed an acceptance of such provisions or as a waiver of the provisions of this contract.
15. **Compliance With Laws, Rules and Regulations** — In the performance of its obligations hereunder, Seller shall comply with all applicable laws, ordinances, rules and regulations including, without limitation: Executive Order 11246 (Equal Employment Opportunity); Executive Order 11625 (Minority Business Enterprises), Vocational Rehabilitation Act of 1973 and Executive Order 11758 (Employment of Handicapped Persons); Veterans Employment and Readjustment Act of 1972 and Executive Order 11701 (Disabled Veterans and Vietnam Veterans); Executive Order 11141 (Age Discrimination in Employment); and Fair Labor Standards Act of 1938.
16. **Timing of Billing to Buyer** - Seller will invoice Buyer upon shipment from its supplier or facility, unless otherwise indicated on the face of this document.
17. **Storage of Material For Buyer** - If, at Buyer's request, goods covered by this document are held at Seller's facility or service provider for more than 21 days after they are available for shipment, Buyer shall accept Seller's invoice and pay said invoice based on payment terms set forth herein.
18. **Material Reservation** - Seller will only reserve material for 30 days with receipt of an executed purchase order, quote or order acknowledgement acceptable to Seller. After that time, material availability, price and shipment date may be adjusted, at Seller's option.
19. Any additional cost of Partial Shipments (less than full truckload) shall be paid for by Buyer and shall be F.O.B., shipping point.
20. Erection from trucks or dropped trailers is not included. Additional trucking costs will be the Buyer's responsibility.
21. Drawing lead times furnished upon request.
22. Approved list of material or an approved drawing containing such list must be in Seller's hand before material is reserved or fabrication scheduled. If requested, Buyer shall furnish Seller one (1) set of contract drawings and specifications.

23. Buyer must cause shop drawings to be reviewed and returned to Seller within 30 days after receipt in order for Seller to maintain its delivery schedule.
24. Contract revisions submitted after Seller's shop drawings are in process will be subject to additional charges at current detailing rates per man-hour.
25. If Seller is called to the field because of an alleged error or missing material and Seller sends personnel to the jobsite to correct the error and an error is not found or locates missing material on job site, then the Seller shall be reimbursed the rate of \$100.00 per man hour portal to portal, plus expenses.
26. Buyer shall reimburse Seller for additional costs plus 20% overhead thereon attributable to mistakes in design furnished by or through Buyer and for other work performed by Seller, at Buyer's request, that is beyond the scope of this Quotation. The parties agree that this is a reasonable estimate of the compensation due to Seller and that the amount of such compensation would otherwise be difficult to establish.
27. If Buyer does not accept delivery of material on agreed upon dates, Seller may, at its discretion, bill for storage charges of 1% per month.
28. Delivery sequences must be established prior to the release by Seller of production orders. Changes in agreed upon sequences could, at Seller's discretion, result in additional charges.
29. The Buyer agrees to carefully check material against shipping papers upon unloading at destination. All claims for shortages or for improper, defective or damaged material will be deemed waived by the Buyer unless written notice specifying in detail the nature and extent of the shortage, defect or damage is mailed to Seller's address within five (5) days from the later of unloading or the earliest possible date the shortage, defect or damage could have been detected by Buyer or its employees, agents or contractors, accompanied in the case of claim for shortage or damage by statement of the local agent of the carrier as to the items and quantity short or damaged. Seller shall have no liability for work or repairs performed by Buyer without Seller's prior approval.
30. Unless specified, aluminum tubing, components and extrusions will be furnished in mill finish per ASTM B221, which permits a certain amount of extrusion marks. Any cleaning or removal of these marks will be performed by others.
31. Prices for aluminum tubing are based upon shipping via van. If flatbed required, additional costs shall be paid for by Buyer and shall be F.O.B., shipping point, freight allowed to job site.
32. Buyer agrees to accept title to said material and Foster will issue an invoice on the initially established delivery date or as soon thereafter as materials are ready for delivery, whichever occurs later.
33. All our quotes exclude third party inspection and testing.
34. For unit price quotations, the quantity invoiced will be based on the actual quantity shipped which may vary from the quantity quoted.



# VENDOR PREFERENCE CERTIFICATE

Certification and application\* is hereby made for Preference in accordance with **West Virginia Code**, §5A-3-37. (Does not apply to construction contracts). **West Virginia Code**, §5A-3-37, provides an opportunity for qualifying vendors to request (at the time of bid) preference for their residency status. Such preference is an evaluation method only and will be applied only to the cost bid in accordance with the **West Virginia Code**. This certificate for application is to be used to request such preference. The Purchasing Division will make the determination of the Resident Vendor Preference, if applicable.

Not Applicable

1. **Application is made for 2.5% resident vendor preference for the reason checked:**  
 Bidder is an individual resident vendor and has resided continuously in West Virginia for four (4) years immediately preceding the date of this certification; **or**,  
 Bidder is a partnership, association or corporation resident vendor and has maintained its headquarters or principal place of business continuously in West Virginia for four (4) years immediately preceding the date of this certification; **or** 80% of the ownership interest of Bidder is held by another individual, partnership, association or corporation resident vendor who has maintained its headquarters or principal place of business continuously in West Virginia for four (4) years immediately preceding the date of this certification; **or**,  
 Bidder is a nonresident vendor which has an affiliate or subsidiary which employs a minimum of one hundred state residents and which has maintained its headquarters or principal place of business within West Virginia continuously for the four (4) years immediately preceding the date of this certification; **or**,
2. **Application is made for 2.5% resident vendor preference for the reason checked:**  
 Bidder is a resident vendor who certifies that, during the life of the contract, on average at least 75% of the employees working on the project being bid are residents of West Virginia who have resided in the state continuously for the two years immediately preceding submission of this bid; **or**,
3. **Application is made for 2.5% resident vendor preference for the reason checked:**  
 Bidder is a nonresident vendor employing a minimum of one hundred state residents or is a nonresident vendor with an affiliate or subsidiary which maintains its headquarters or principal place of business within West Virginia employing a minimum of one hundred state residents who certifies that, during the life of the contract, on average at least 75% of the employees or Bidder's affiliate's or subsidiary's employees are residents of West Virginia who have resided in the state continuously for the two years immediately preceding submission of this bid; **or**,
4. **Application is made for 5% resident vendor preference for the reason checked:**  
 Bidder meets either the requirement of both subdivisions (1) and (2) or subdivision (1) and (3) as stated above; **or**,
5. **Application is made for 3.5% resident vendor preference who is a veteran for the reason checked:**  
 Bidder is an individual resident vendor who is a veteran of the United States armed forces, the reserves or the National Guard and has resided in West Virginia continuously for the four years immediately preceding the date on which the bid is submitted; **or**,
6. **Application is made for 3.5% resident vendor preference who is a veteran for the reason checked:**  
 Bidder is a resident vendor who is a veteran of the United States armed forces, the reserves or the National Guard, if, for purposes of producing or distributing the commodities or completing the project which is the subject of the vendor's bid and continuously over the entire term of the project, on average at least seventy-five percent of the vendor's employees are residents of West Virginia who have resided in the state continuously for the two immediately preceding years.

Bidder understands if the Secretary of Revenue determines that a Bidder receiving preference has failed to continue to meet the requirements for such preference, the Secretary may order the Director of Purchasing to: (a) reject the bid; or (b) assess a penalty against such Bidder in an amount not to exceed 5% of the bid amount and that such penalty will be paid to the contracting agency or deducted from any unpaid balance on the contract or purchase order.

By submission of this certificate, Bidder agrees to disclose any reasonably requested information to the Purchasing Division and authorizes the Department of Revenue to disclose to the Director of Purchasing appropriate information verifying that Bidder has paid the required business taxes, provided that such information does not contain the amounts of taxes paid nor any other information deemed by the Tax Commissioner to be confidential.

**Under penalty of law for false swearing (West Virginia Code, §61-5-3), Bidder hereby certifies that this certificate is true and accurate in all respects; and that if a contract is issued to Bidder and if anything contained within this certificate changes during the term of the contract, Bidder will notify the Purchasing Division in writing immediately.**

Bidder: L. B. Foster Co.

Signed: [Signature]

Date: 4/23/12

Title: District Sales Mgr.

\*Check any combination of preference consideration(s) indicated above, which you are entitled to receive.



STATE OF WEST VIRGINIA  
Purchasing Division

**PURCHASING AFFIDAVIT**

**West Virginia Code §5A-3-10a states:** No contract or renewal of any contract may be awarded by the state or any of its political subdivisions to any vendor or prospective vendor when the vendor or prospective vendor or a related party to the vendor or prospective vendor is a debtor and the debt owed is an amount greater than one thousand dollars in the aggregate.

**DEFINITIONS:**

"Debt" means any assessment, premium, penalty, fine, tax or other amount of money owed to the state or any of its political subdivisions because of a judgment, fine, permit violation, license assessment, defaulted workers' compensation premium, penalty or other assessment presently delinquent or due and required to be paid to the state or any of its political subdivisions, including any interest or additional penalties accrued thereon.

"Debtor" means any individual, corporation, partnership, association, limited liability company or any other form or business association owing a debt to the state or any of its political subdivisions. "Political subdivision" means any county commission; municipality; county board of education; any instrumentality established by a county or municipality; any separate corporation or instrumentality established by one or more counties or municipalities, as permitted by law; or any public body charged by law with the performance of a government function or whose jurisdiction is coextensive with one or more counties or municipalities. "Related party" means a party, whether an individual, corporation, partnership, association, limited liability company or any other form or business association or other entity whatsoever, related to any vendor by blood, marriage, ownership or contract through which the party has a relationship of ownership or other interest with the vendor so that the party will actually or by effect receive or control a portion of the benefit, profit or other consideration from performance of a vendor contract with the party receiving an amount that meets or exceed five percent of the total contract amount.

**EXCEPTION:** The prohibition of this section does not apply where a vendor has contested any tax administered pursuant to chapter eleven of this code, workers' compensation premium, permit fee or environmental fee or assessment and the matter has not become final or where the vendor has entered into a payment plan or agreement and the vendor is not in default of any of the provisions of such plan or agreement.

Under penalty of law for false swearing (*West Virginia Code* §61-5-3), it is hereby certified that the vendor affirms and acknowledges the information in this affidavit and is in compliance with the requirements as stated.

**WITNESS THE FOLLOWING SIGNATURE**

Vendor's Name: L.B. Foster Co.

Authorized Signature: [Signature] Date: 4/23/12

State of Kentucky

County of Fayette, to-wit:

Taken, subscribed, and sworn to before me this 23<sup>d</sup> day of April, 2012.

My Commission expires July 22, 2015.

**AFFIX SEAL HERE**

NOTARY PUBLIC [Signature]

