



State of West Virginia  
 Department of Administration  
 Purchasing Division  
 2019 Washington Street East  
 Post Office Box 50130  
 Charleston, WV 25305-0130

# Request for Quotation

RFQ NUMBER  
**VET10112**

PAGE  
**1**

ADDRESS CORRESPONDENCE TO ATTENTION OF  
 BUYER 32  
 304-558-2544

RFQ COPY

TYPE NAME/ADDRESS HERE

Kanawha Stone Company, Inc.  
 401 Jacobson Drive  
 Poca, WV 25159

DIVISION OF VETERANS AFFAIRS  
 ATTENTION: C. PRATHER  
 SUITE 101  
 1321 PLAZA EAST  
 CHARLESTON, WV  
 25301-1400 558-3661

VENDOR

SHIP TO

DATE PRINTED	TERMS OF SALE	SHIP VIA	F.O.B.	FREIGHT TERMS
06/14/2010				

BID OPENING DATE: **07/27/2010** BID OPENING TIME **01:30PM**

LINE	QUANTITY	UOP	CAT NO	ITEM NUMBER	UNIT PRICE	AMOUNT
0001	1	JB		968-42		
<p><b>CEMETERY GROUNDS &amp; FACILITY CONSTRUCTION</b></p> <p>THE WEST VIRGINIA PURCHASING DIVISION, FOR THE AGENCY, THE WEST VIRGINIA DIVISION OF VETERANS AFFAIRS, IS SOLICITING BIDS FROM QUALIFIED VENDORS TO PROVIDE ALL LABOR AND MATERIALS TO CONSTRUCT THE DONEL KINNARD MEMORIAL STATE VETERANS CEMETERY IN INSTITUTE, WEST VIRGINIA, (KANAWHA CO.), PER THE FOLLOWING BID REQUIREMENTS, TERMS &amp; CONDITIONS, AND THE PLANS AND SPECIFICATIONS AS PREPARED BY BLACKWOOD ASSOCIATES, INC.</p> <p>ALL QUESTIONS RELATING TO THIS PROJECT ARE TO BE DIRECTED TO THE BUYER ASSIGNED TO THIS REQUEST FOR QUOTATION, CHUCK BOWMAN. MR. BOWMAN MAY BE REACHED AT 304.558.2157 OR BY E-MAIL AT CHARLES.A.BOWMANJR@WV.GOV</p> <p>TECHNICAL QUESTIONS MUST BE SUBMITTED IN WRITING TO THE BUYER AND WILL BE FORWARDED TO THE AGENCY FOR THE REVIEW AND ADVISEMENT OF THE ARCHITECT OF RECORD. ALL QUESTIONS WILL BE OFFICIALLY ANSWERED IN ADDENDUM FORM AS DETAILED HEREIN.</p> <p>EXCEPT FOR THE PURPOSE OF PROCURING PLANS AND SPECIFICATIONS, VENDORS SHOULD NOT HAVE DIRECT CONTACT WITH THE ARCHITECT AT ANY TIME DURING THE ADVERTISEMENT OF THIS PROJECT PRIOR TO THE BID OPENING DATE.</p> <p>INSTRUCTIONS FOR OBTAINING THE PLANS &amp; SPECIFICATIONS ARE INCLUDED IN THE ATTACHED INVITATION TO BID.</p> <p style="text-align: center;">MANDATORY PRE-BID</p>						

RECEIVED  
 2010 JUL 13 PM 1:13  
 WV PURCHASING DIVISION

SEE REVERSE SIDE FOR TERMS AND CONDITIONS			
SIGNATURE <i>Virginia L. King</i>	TELEPHONE (304) 755-8271	DATE 7/13/2010	
TITLE Vice President	FEIN 550535003	ADDRESS CHANGES TO BE NOTED ABOVE	

WHEN RESPONDING TO RFQ, INSERT NAME AND ADDRESS IN SPACE ABOVE LABELED 'VENDOR'

## GENERAL TERMS & CONDITIONS REQUEST FOR QUOTATION (RFQ) AND REQUEST FOR PROPOSAL (RFP)

1. Awards will be made in the best interest of the State of West Virginia.
  2. The State may accept or reject in part, or in whole, any bid.
  3. Prior to any award, the apparent successful vendor must be properly registered with the Purchasing Division and have paid the required \$125 fee.
  4. All services performed or goods delivered under State Purchase Order/Contracts are to be continued for the term of the Purchase Order/Contracts, contingent upon funds being appropriated by the Legislature or otherwise being made available. In the event funds are not appropriated or otherwise available for these services or goods this Purchase Order/Contract becomes void and of no effect after June 30.
  5. Payment may only be made after the delivery and acceptance of goods or services.
  6. Interest may be paid for late payment in accordance with the *West Virginia Code*.
  7. Vendor preference will be granted upon written request in accordance with the *West Virginia Code*.
  8. The State of West Virginia is exempt from federal and state taxes and will not pay or reimburse such taxes.
  9. The Director of Purchasing may cancel any Purchase Order/Contract upon 30 days written notice to the seller.
  10. The laws of the State of West Virginia and the *Legislative Rules* of the Purchasing Division shall govern the purchasing process.
  11. Any reference to automatic renewal is hereby deleted. The Contract may be renewed only upon mutual written agreement of the parties.
  12. **BANKRUPTCY:** In the event the vendor/contractor files for bankruptcy protection, the State may deem this contract null and void, and terminate such contract without further order.
  13. **HIPAA BUSINESS ASSOCIATE ADDENDUM:** The West Virginia State Government HIPAA Business Associate Addendum (BAA), approved by the Attorney General, is available online at [www.state.wv.us/admin/purchase/vrc/hipaa.htm](http://www.state.wv.us/admin/purchase/vrc/hipaa.htm) and is hereby made part of the agreement. Provided that the Agency meets the definition of a Cover Entity (45 CFR §160.103) and will be disclosing Protected Health Information (45 CFR §160.103) to the vendor.
  14. **CONFIDENTIALITY:** The vendor agrees that he or she will not disclose to anyone, directly or indirectly, any such personally identifiable information or other confidential information gained from the agency, unless the individual who is the subject of the information consents to the disclosure in writing or the disclosure is made pursuant to the agency's policies, procedures, and rules. Vendor further agrees to comply with the Confidentiality Policies and Information Security Accountability Requirements, set forth in <http://www.state.wv.us/admin/purchase/privacy/noticeConfidentiality.pdf>.
  15. **LICENSING:** Vendors must be licensed and in good standing in accordance with any and all state and local laws and requirements by any state or local agency of West Virginia, including, but not limited to, the West Virginia Secretary of State's Office, the West Virginia Tax Department, and the West Virginia Insurance Commission. The vendor must provide all necessary releases to obtain information to enable the director or spending unit to verify that the vendor is licensed and in good standing with the above entities.
  16. **ANTITRUST:** In submitting a bid to any agency for the State of West Virginia, the bidder offers and agrees that if the bid is accepted the bidder will convey, sell, assign or transfer to the State of West Virginia all rights, title and interest in and to all causes of action it may now or hereafter acquire under the antitrust laws of the United States and the State of West Virginia for price fixing and/or unreasonable restraints of trade relating to the particular commodities or services purchased or acquired by the State of West Virginia. Such assignment shall be made and become effective at the time the purchasing agency tenders the initial payment to the bidder.
- I certify that this bid is made without prior understanding, agreement, or connection with any corporation, firm, limited liability company, partnership, or person or entity submitting a bid for the same material, supplies, equipment or services and is in all respects fair and without collusion or Fraud. I further certify that I am authorized to sign the certification on behalf of the bidder or this bid.

### INSTRUCTIONS TO BIDDERS

1. Use the quotation forms provided by the Purchasing Division. Complete all sections of the quotation form.
2. Items offered must be in compliance with the specifications. Any deviation from the specifications must be clearly indicated by the bidder. Alternates offered by the bidder as **EQUAL** to the specifications must be clearly defined. A bidder offering an alternate should attach complete specifications and literature to the bid. The Purchasing Division may waive minor deviations to specifications.
3. Unit prices shall prevail in case of discrepancy. All quotations are considered F.O.B. destination unless alternate shipping terms are clearly identified in the quotation.
4. All quotations must be delivered by the bidder to the office listed below prior to the date and time of the bid opening. Failure of the bidder to deliver the quotations on time will result in bid disqualifications: Department of Administration, Purchasing Division, 2019 Washington Street East, P.O. Box 50130, Charleston, WV 25305-0130
5. Communication during the solicitation, bid, evaluation or award periods, except through the Purchasing Division, is strictly prohibited (W.Va. C.S.R. §148-1-6.6).



State of West Virginia  
 Department of Administration  
 Purchasing Division  
 2019 Washington Street East  
 Post Office Box 50130  
 Charleston, WV 25305-0130

# Request for Quotation

RFQ NUMBER  
 VET10112

PAGE  
 2

ADDRESS CORRESPONDENCE TO ATTENTION OF  
 BUYER 32  
 304-558-2544

VENDOR

RFQ COPY  
 TYPE NAME/ADDRESS HERE  
 Kanawha Stone Company, Inc.  
 401 Jacobson Drive  
 Poca, WV 25159

SHIP TO

DIVISION OF VETERANS AFFAIRS  
 ATTENTION: C. PRATHER  
 SUITE 101  
 1321 PLAZA EAST  
 CHARLESTON, WV  
 25301-1400 558-3661

DATE PRINTED	TERMS OF SALE	SHIP VIA	F.O.B.	FREIGHT TERMS
06/14/2010				

BID OPENING DATE: 07/27/2010 BID OPENING TIME 01:30PM

LINE	QUANTITY	UOP	CAT NO	ITEM NUMBER	UNIT PRICE	AMOUNT
<p>A MANDATORY PRE-BID WILL BE HELD ON JUNE 29, 2010, AT 10:00AM AT THE WEST VIRGINIA STATE POLICE ACADEMY LOCATED AT 135 ACADEMY DRIVE, DUNBAR, WV. 25064.</p> <p>INTERESTED PARTIES ARE REQUIRED TO ATTEND THIS MEETING FAILURE TO ATTEND THE MANDATORY PRE-BID SHALL RESULT IN DISQUALIFICATION OF THE BID. NO ONE PERSON MAY REPRESENT MORE THAN ONE BIDDER.</p> <p>AN ATTENDANCE SHEET WILL BE MADE AVAILABLE FOR ALL POTENTIAL BIDDERS TO COMPLETE. THIS WILL SERVE AS THE OFFICIAL DOCUMENT VERIFYING ATTENDANCE AT THE MANDATORY PRE-BID. FAILURE TO PROVIDE YOUR COMPANY AND REPRESENTATIVE NAME ON THE ATTENDANCE SHEET WILL RESULT IN DISQUALIFICATION OF THE BID. THE STATE WILL NOT ACCEPT ANY OTHER DOCUMENTATION TO VERIFY ATTENDANCE. THE BIDDER IS RESPONSIBLE FOR ENSURING THEY HAVE COMPLETED THE INFORMATION REQUIRED ON THE ATTENDANCE SHEET. THE PURCHASING DIVISION AND THE STATE AGENCY WILL NOT ASSUME ANY RESPONSIBILITY FOR A BIDDER'S FAILURE TO COMPLETE THE PRE-BID ATTENDANCE SHEET. IN ADDITION, WE REQUEST THAT ALL POTENTIAL BIDDERS INCLUDE THEIR E-MAIL ADDRESS AND FAX NUMBER.</p> <p>ALL POTENTIAL BIDDERS ARE REQUESTED TO ARRIVE PRIOR TO THE STARTING TIME FOR THE PRE-BID. BIDDERS WHO ARRIVE LATE, BUT PRIOR TO THE DISMISSAL OF THE TECHNICAL PORTION OF THE PRE-BID WILL BE PERMITTED TO SIGN IN. BIDDERS WHO ARRIVE AFTER CONCLUSION OF THE TECHNICAL PORTION OF THE PRE-BID, BUT DURING ANY SUBSEQUENT PART OF THE PRE-BID WILL NOT BE PERMITTED TO SIGN THE ATTENDANCE SHEET.</p> <p>EXHIBIT 5</p>						

SEE REVERSE SIDE FOR TERMS AND CONDITIONS

SIGNATURE <i>Virginia R. Howard</i>	TELEPHONE (304) 755-8271	DATE 7/13/2010
TITLE Vice President	FEIN 550535003	ADDRESS CHANGES TO BE NOTED ABOVE



State of West Virginia  
 Department of Administration  
 Purchasing Division  
 2019 Washington Street East  
 Post Office Box 50130  
 Charleston, WV 25305-0130

# Request for Quotation

RFQ NUMBER
VET10112

PAGE
3

ADDRESS CORRESPONDENCE TO ATTENTION OF
BUYER 32 304-558-2544

VENDOR

RFQ COPY  
 TYPE NAME/ADDRESS HERE  
 Kanawha Stone Company, Inc.  
 401 Jacobson Drive  
 Poca, WV 25159

SHIP TO

DIVISION OF VETERANS AFFAIRS  
 ATTENTION: C. PRATHER  
 SUITE 101  
 1321 PLAZA EAST  
 CHARLESTON, WV  
 25301-1400 558-3661

DATE PRINTED	TERMS OF SALE	SHIP VIA	F.O.B.	FREIGHT TERMS
06/14/2010				

BID OPENING DATE: 07/27/2010 BID OPENING TIME 01:30PM

LINE	QUANTITY	UOP	CAT NO	ITEM NUMBER	UNIT PRICE	AMOUNT
<p>WEST VIRGINIA CODE 21-1D-5 PROVIDES THAT: ANY SOLICITATION FOR A PUBLIC IMPROVEMENT CONSTRUCTION CONTRACT REQUIRES EACH VENDOR THAT SUBMITS A BID FOR THE WORK TO SUBMIT AT THE SAME TIME AN AFFIDAVIT OF COMPLIANCE WITH THE BID. THE ENCLOSED DRUG-FREE WORKPLACE AFFIDAVIT MUST BE SIGNED AND SUBMITTED WITH THE BID AS EVIDENCE OF THE VENDOR'S COMPLIANCE WITH THE PROVISIONS OF ARTICLE 1D, CHAPTER 21 OF THE WEST VIRGINIA CODE. FAILURE TO SUBMIT THE SIGNED DRUG-FREE WORKPLACE AFFIDAVIT WITH THE BID SHALL RESULT IN DISQUALIFICATION OF SUCH BID.</p> <p>NOTICE TO PROCEED: THIS CONTRACT IS TO BE PERFORMED WITHIN 390 CALENDAR DAYS AFTER THE NOTICE TO PROCEED IS RECEIVED. UNLESS OTHERWISE SPECIFIED, THE FULLY EXECUTED PURCHASE ORDER WILL BE CONSIDERED NOTICE TO PROCEED.</p> <p>CANCELLATION: THE DIRECTOR OF PURCHASING RESERVES THE RIGHT TO CANCEL THIS CONTRACT IMMEDIATELY UPON WRITTEN NOTICE TO THE VENDOR IF THE MATERIALS OR WORKMANSHIP SUPPLIED ARE OF AN INFERIOR QUALITY OR DO NOT CONFORM WITH THE SPECIFICATIONS OF THE BID AND CONTRACT HERE IN.</p> <p>WAGE RATES: THE CONTRACTOR OR SUBCONTRACTOR SHALL PAY THE HIGHER OF THE U.S. DEPARTMENT OF LABOR MINIMUM WAGE RATES AS ESTABLISHED FOR KANAWHA COUNTY, PURSUANT TO WEST VIRGINIA CODE 21-5A, ET, SEQ. (PREVAILING WAGE RATES APPLY TO THIS PROJECT)</p> <p>ARBITRATION: ANY REFERENCES MADE TO ARBITRATION OR INTEREST FOR PAYMENTS DUE (EXCEPT FOR ANY INTEREST REQUIRED BY STATE LAW) CONTAINED IN THIS CONTRACT OR IN ANY AMERICAN INSTITUTE OF ARCHITECTS DOCUMENTS PERTAINING TO THIS CONTRACT ARE HEREBY DELETED.</p>						

SEE REVERSE SIDE FOR TERMS AND CONDITIONS

SIGNATURE <i>Virginia S. Hume</i>	TELEPHONE (304) 755-8271	DATE 7/13/2010
TITLE Vice President	FERN 550535003	ADDRESS CHANGES TO BE NOTED ABOVE

WHEN RESPONDING TO RFQ, INSERT NAME AND ADDRESS IN SPACE ABOVE LABELLED 'VENDOR'



State of West Virginia  
 Department of Administration  
 Purchasing Division  
 2019 Washington Street East  
 Post Office Box 50130  
 Charleston, WV 25305-0130

# Request for Quotation

RFQ NUMBER  
**VET10112**

PAGE  
**4**

ADDRESS CORRESPONDENCE TO ATTENTION OF  
 BUYER 32  
 304-558-2544

VENDOR FOR

RFQ COPY  
 TYPE NAME/ADDRESS HERE  
 Kanawha Stone Company, Inc.  
 401 Jacobson Drive  
 Poca, WV 25159

SHIP TO

DIVISION OF VETERANS AFFAIRS  
 ATTENTION: C. PRATHER  
 SUITE 101  
 1321 PLAZA EAST  
 CHARLESTON, WV  
 25301-1400 558-3661

DATE PRINTED	TERMS OF SALE	SHIP VIA	F.O.B.	FREIGHT TERMS
06/14/2010				

BID OPENING DATE: **07/27/2010** BID OPENING TIME **01:30PM**

LINE	QUANTITY	UOP	CAT NO	ITEM NUMBER	UNIT PRICE	AMOUNT
<p>WORKERS' COMPENSATION: VENDOR IS REQUIRED TO PROVIDE A CERTIFICATE FROM WORKERS' COMPENSATION IF SUCCESSFUL.</p> <p>ALL OF THE ITEMS CHECKED BELOW WILL BE A REQUIREMENT OF THIS CONTRACT:</p> <p>(XX) INSURANCE: SUCCESSFUL VENDOR SHALL FURNISH PROOF OF COMMERCIAL GENERAL LIABILITY INSURANCE PRIOR TO ISSUANCE OF CONTRACT. UNLESS OTHERWISE SPECIFIED IN THE BID DOCUMENTS, THE MINIMUM AMOUNT OF INSURANCE COVERAGE REQUIRED IS \$250,000.</p> <p>(XX) BUILDERS RISK INSURANCE: SUCCESSFUL VENDOR SHALL FURNISH PROOF OF BUILDERS RISK - ALL RISK INSURANCE IN AN AMOUNT EQUAL TO 100% OF THE AMOUNT OF THE CONTRACT.</p> <p>(XX) BONDS: FIVE PERCENT (5%) OF THE TOTAL AMOUNT OF THE BID PAYABLE TO THE STATE OF WEST VIRGINIA, SHALL BE SUBMITTED WITH EACH BID AS A BID BOND. THE SUCCESSFUL BIDDER SHALL ALSO FURNISH A PERFORMANCE BOND AND LABOR/MATERIAL BOND FOR 100% OF THE AMOUNT OF THE CONTRACT. BONDS MAY BE PROVIDED IN THE FORM OF A CERTIFIED CHECK, IRREVOCABLE LETTER OF CREDIT, OR BOND FURNISHED BY A SOLVENT SURETY COMPANY AUTHORIZED TO DO BUSINESS IN THE STATE OF WEST VIRGINIA. A LETTER OF CREDIT SUBMITTED IN LIEU OF A BOND WILL ONLY BE ALLOWED FOR PROJECTS UNDER \$100,000. PERSONAL OR BUSINESS CHECKS ARE NOT ACCEPTABLE IN LIEU OF THE 5% BID BOND, PERFORMANCE BOND, OR LABOR AND MATERIAL BOND.</p> <p>(XX) MAINTENANCE BOND: A TWO (2) YEAR MAINTENANCE BOND COVERING THE ROOFING SYSTEM WILL BE A REQUIREMENT OF THE SUCCESSFUL VENDOR.</p> <p>REV. 11/00</p>						

SEE REVERSE SIDE FOR TERMS AND CONDITIONS

SIGNATURE <i>Virginia S. Fine</i>	TELEPHONE (304) 755-8271	DATE 7/13/2010
TITLE Vice President	FEIN 550535003	ADDRESS CHANGES TO BE NOTED ABOVE



State of West Virginia  
Department of Administration  
Purchasing Division  
2019 Washington Street East  
Post Office Box 50130  
Charleston, WV 25305-0130

# Request for Quotation

RFQ NUMBER
VET10112

PAGE
5

ADDRESS CORRESPONDENCE TO ATTENTION OF
BUYER 32 304-558-2544

V E N D O R	RFQ COPY
	TYPE NAME/ADDRESS HERE

Kanawha Stone Company, Inc.  
401 Jacobson Drive  
Poca, WV 25159

S H I P T O	DIVISION OF VETERANS AFFAIRS
	ATTENTION: C. PRATHER
	SUITE 101
	1321 PLAZA EAST
	CHARLESTON, WV 25301-1400 558-3661

DATE PRINTED	TERMS OF SALE	SHIP VIA	F.O.B	FREIGHT TERMS
06/14/2010				

BID OPENING DATE: 07/27/2010 BID OPENING TIME 01:30PM

LINE	QUANTITY	UOP	CAT NO	ITEM NUMBER	UNIT PRICE	AMOUNT
				EXHIBIT 7		
				DOMESTIC ALUMINUM, GLASS & STEEL IN PUBLIC WORKS PROJECTS		
				IN ACCORDANCE WITH WEST VIRGINIA CODE 5-19-1 ET., SEQ., EVERY CONTRACT FOR CONSTRUCTION, RECONSTRUCTION, ALTERATION, REPAIR, IMPROVEMENT OR MAINTENANCE OF PUBLIC WORKS, WHERE THE COST IS MORE THAN \$50,000 AND, IN THE CASE OF STEEL ONLY, WHERE THE COST OF STEEL IS MORE THAN \$50,000 OR WHERE MORE THAN 10,000 POUNDS OF STEEL ARE REQUIRED, THE STATE WILL ACCEPT ONLY ALUMINUM GLASS, OR STEEL PRODUCTS PRODUCED IN THE UNITED STATES. IN ADDITION, ITEMS OF MACHINERY OR EQUIPMENT PURCHASED FOR USE AT THE SITE OF PUBLIC WORKS SHALL BE MADE OF DOMESTIC ALUMINUM, GLASS OR STEEL, UNLESS THE COST OF THE PRODUCT IS LESS THAN \$50,000 OR LESS THAN 10,000 POUNDS OF STEEL ARE USED IN PUBLIC WORKS PROJECTS.		
				FOREIGN MADE ALUMINUM, GLASS OR STEEL PRODUCTS MAY BE ACCEPTED ONLY IF THE COST OF DOMESTIC PRODUCTS IS FOUND TO BE UNREASONABLE. SUCH COST IS UNREASONABLE IF IT IS 20% OR MORE HIGHER THAN THE BID PRICE FOR FOREIGN MADE PRODUCTS. IF THE DOMESTIC ALUMINUM, GLASS OR STEEL PRODUCTS TO BE SUPPLIED OR PRODUCED IN A "SUBSTANTIAL LABOR SURPLUS AREA", AS DEFINED BY THE UNITED STATES DEPARTMENT OF LABOR, FOREIGN PRODUCTS MAY BE SUPPLIED ONLY IF DOMESTIC PRODUCTS ARE 30% OR MORE HIGHER IN PRICE THAN THE FOREIGN MADE PRODUCTS.		
				IF, PRIOR TO THE AWARD OF A CONTRACT UNDER THE ABOVE PROVISIONS, THE SPENDING OFFICER OF THE SPENDING UNIT DETERMINES THAT THERE EXISTS A BID FOR LIKE FOREIGN ALUMINUM, GLASS OR STEEL THAT IS REASONABLE AND LOWER THAN THE LOWEST BID DOMESTIC PRODUCTS, THE SPENDING		

SEE REVERSE SIDE FOR TERMS AND CONDITIONS

SIGNATURE <i>Virginia S. King</i>	TELEPHONE (304) 755-8271	DATE 7/13/2010
TITLE Vice President	FEIN 550535003	ADDRESS CHANGES TO BE NOTED ABOVE

WHEN RESPONDING TO RFQ, INSERT NAME AND ADDRESS IN SPACE ABOVE LABELED 'VENDOR'



State of West Virginia  
 Department of Administration  
 Purchasing Division  
 2019 Washington Street East  
 Post Office Box 50130  
 Charleston, WV 25305-0130

# Request for Quotation

RFQ NUMBER  
 VET10112

PAGE  
 6

ADDRESS CORRESPONDENCE TO ATTENTION OF  
 BUYER 32  
 304-558-2544

VENDOR

RFQ COPY  
 TYPE NAME/ADDRESS HERE

Kanawha Stone Company, Inc.  
 401 Jacobson Drive  
 Poca, WV 25159

SHIP TO

DIVISION OF VETERANS AFFAIRS  
 ATTENTION: C. PRATHER  
 SUITE 101  
 1321 PLAZA EAST  
 CHARLESTON, WV  
 25301-1400 558-3661

DATE PRINTED	TERMS OF SALE	SHIP VIA	F.O.B	FREIGHT TERMS
06/14/2010				

BID OPENING DATE: 07/27/2010 BID OPENING TIME 01:30PM

LINE	QUANTITY	UOP	CAT NO	ITEM NUMBER	UNIT PRICE	AMOUNT
------	----------	-----	--------	-------------	------------	--------

OFFICE MAY REQUEST, IN WRITING, A REEVALUATION AND REDUCTION IN THE LOWEST BID FOR SUCH DOMESTIC PRODUCTS. ALL VENDORS MUST INDICATE IN THEIR BID IF THEY ARE SUPPLYING FOREIGN ALUMINUM, GLASS OR STEEL.

REV. 3/88

PREFERENCE FOR USE OF DOMESTIC STEEL PRODUCTS

1. EXCEPT WHEN AUTHORIZED BY THE DIRECTOR OF THE PURCHASING DIVISION PURSUANT TO SUBSECTION 2 BELOW NO CONTRACTOR MAY USE OR SUPPLY STEEL PRODUCTS FOR A STATE CONTRACT PROJECT OTHER THAN THOSE STEEL PRODUCTS MADE IN THE UNITED STATES. AS USED IN THIS CONTRACT,
  - A. "STATE CONTRACT PROJECT" MEANS ANY ERECTION OR CONSTRUCTION OF, OR ANY ADDITION TO, ALTERATION OF OR OTHER IMPROVEMENT TO ANY BUILDING OR STRUCTURE, INCLUDING, BUT NOT LIMITED TO, ROADS OR HIGHWAYS, OR THE INSTALLATION OF ANY HEATING OR COOLING OR VENTILATING PLANTS OR OTHER EQUIPMENT, OR THE SUPPLY OF AND MATERIALS FOR SUCH PROJECTS, PURSUANT TO A CONTRACT WITH THE STATE OF WEST VIRGINIA FOR WHICH BIDS WERE SOLICITED ON OR AFTER JUNE 6, 2001.
  - B. "STEEL PRODUCTS" MEANS PRODUCTS ROLLED, FORMED, SHAPED, DRAWN, EXTRUDED, FORGED, CAST, FABRICATED OR OTHERWISE SIMILARLY PROCESSED, OR PROCESSED BY A COMBINATION OF TWO OR MORE OF SUCH OPERATIONS, FROM STEEL MADE BY THE OPEN HEARTH, BASIC OXYGEN, ELECTRIC FURNACE, BESSEMER OR OTHER STEEL MAKING PROCESS.

SEE REVERSE SIDE FOR TERMS AND CONDITIONS

SIGNATURE <i>Virginia L. Kue</i>	TELEPHONE (304) 755-8271	DATE 7/13/2010
TITLE Vice President	FEIN 550535003	ADDRESS CHANGES TO BE NOTED ABOVE



State of West Virginia  
 Department of Administration  
 Purchasing Division  
 2019 Washington Street East  
 Post Office Box 50130  
 Charleston, WV 25305-0130

# Request for Quotation

RFQ NUMBER
VET10112

PAGE
7

ADDRESS CORRESPONDENCE TO ATTENTION OF
BUYER 32 304-558-2544

RFQ COPY  
 TYPE NAME/ADDRESS HERE  
 Kanawha Stone Company, Inc.  
 401 Jacobson Drive  
 Poca, WV 25159

V  
E  
N  
D  
O  
R

DIVISION OF VETERANS AFFAIRS  
 ATTENTION: C. PRATHER  
 SUITE 101  
 1321 PLAZA EAST  
 CHARLESTON, WV  
 25301-1400 558-3661

S  
H  
I  
P  
T  
O

DATE PRINTED	TERMS OF SALE	SHIP VIA	FOB	FREIGHT TERMS
06/14/2010				

BID OPENING DATE: 07/27/2010 BID OPENING TIME 01:30PM

LINE	QUANTITY	UOP	CAT NO	ITEM NUMBER	UNIT PRICE	AMOUNT
				C. "UNITED STATES" MEANS THE UNITED STATES OF AMERICA AND INCLUDES ALL TERRITORY, CONTINENTAL OR INSULAR, SUBJECT TO THE JURISDICTION OF THE UNITED STATES.  2. THE DIRECTOR OF THE PURCHASING DIVISION MAY, IN WRITING, AUTHORIZE THE USE OF FOREIGN STEEL PRODUCTS IF:  A. THE COST FOR EACH CONTRACT ITEM USED DOES NOT EXCEED ONE TENTH OF ONE PERCENT (.1%) OF THE TOTAL CONTRACT COST OR TWO THOUSAND FIVE HUNDRED DOLLARS (2,500.00), WHICHEVER IS GREATER. FOR THE PURPOSES OF THIS SECTION, THE COST IS THE VALUE OF THE STEEL PRODUCT AS DELIVERED TO THE PROJECT OR,  B. THE DIRECTOR OF THE PURCHASING DIVISION DETERMINES THAT SPECIFIED STEEL MATERIALS ARE NOT PRODUCED IN THE UNITED STATES IN SUFFICIENT QUANTITY OR OTHERWISE ARE NOT REASONABLY AVAILABLE TO MEET CONTRACT REQUIREMENTS.  3. A CONTRACTOR WHO USES STEEL PRODUCTS IN VIOLATION OF THIS SECTION MAY BE SUBJECT TO CIVIL PENALTIES PURSUANT TO WV CODE SECTION 5A-3-56.  REV. 10/01/01  EXHIBIT 9  NOTICE FOR ISSUANCE & ACKNOWLEDGEMENT OF CONSTRUCTION PROJECT ADDENDA  THE ARCHITECT/ENGINEER AND/OR AGENCY SHALL BE REQUIRED		

SIGNATURE <i>Virginia L. Kune</i>		TELEPHONE (304) 755-8271	DATE 7/13/2010
TITLE Vice President	FEIN 550535003	ADDRESS CHANGES TO BE NOTED ABOVE	

WHEN RESPONDING TO RFQ, INSERT NAME AND ADDRESS IN SPACE ABOVE LABELED 'VENDOR'





State of West Virginia  
 Department of Administration  
 Purchasing Division  
 2019 Washington Street East  
 Post Office Box 50130  
 Charleston, WV 25305-0130

# Request for Quotation

RFQ NUMBER  
 VET10112

PAGE  
 8

ADDRESS CORRESPONDENCE TO ATTENTION OF  
 BUYER 32  
 304-558-2544

VENDOR

RFQ COPY  
 TYPE NAME/ADDRESS HERE  
 Kanawha Stone Company, Inc.  
 401 Jacobson Drive  
 Poca, WV 25159

SHIP TO

DIVISION OF VETERANS AFFAIRS  
 ATTENTION: C. PRATHER  
 SUITE 101  
 1321 PLAZA EAST  
 CHARLESTON, WV  
 25301-1400 558-3661

DATE PRINTED	TERMS OF SALE	SHIP VIA	F.O.B.	FREIGHT TERMS
06/14/2010				

BID OPENING DATE: 07/27/2010 BID OPENING TIME 01:30PM

LINE	QUANTITY	UOP	CAT NO	ITEM NUMBER	UNIT PRICE	AMOUNT
<p>TO ABIDE BY THE FOLLOWING SCHEDULE IN ISSUING CONSTRUCTION PROJECT ADDENDA FOR STATE AGENCIES:</p> <p>(1) THE ARCHITECT/ENGINEER SHALL PREPARE THE ADDENDUM AND A LIST OF ALL PARTIES THAT HAVE PROCURED DRAWINGS AND SPECIFICATIONS FOR THE PROJECT. THE ADDENDUM AND LIST SHALL BE FORWARDED TO THE BUYER IN THE STATE PURCHASING DIVISION. THE ARCHITECT/ENGINEER SHALL ALSO SEND A COPY OF THE ADDENDUM TO THE STATE AGENCY FOR WHICH THE CONTRACT IS ISSUED.</p> <p>(2) THE BUYER SHALL SEND THE ADDENDUM TO ALL INTERESTED PARTIES AND, IF NECESSARY, EXTEND THE BID OPENING DATE. ANY ADDENDUM SHOULD BE RECEIVED BY THE BUYER WITHIN FOURTEEN (14) DAYS PRIOR TO THE BID OPENING DATE.</p> <p>(3) ALL ADDENDA SHOULD BE FORMALLY ACKNOWLEDGED BY ALL BIDDERS AND SUBMITTED TO THE STATE PURCHASING DIVISION. THE SAME RULES AND REGULATIONS THAT APPLY TO THE ORIGINAL BIDDING DOCUMENT SHALL ALSO APPLY TO AN ADDENDUM DOCUMENT. THE ONLY EXCEPTION MAY BE FOR AN ADDENDUM THAT IS ISSUED FOR THE SOLE PURPOSE OF CHANGING A BID OPENING TIME AND/OR DATE.</p> <p>REV. 11/96</p> <p>EXHIBIT 10</p> <p>ADDENDUM ACKNOWLEDGEMENT</p> <p>I HEREBY ACKNOWLEDGE RECEIPT OF THE FOLLOWING CHECKED ADDENDUM(S) AND HAVE MADE THE NECESSARY REVISIONS TO MY PROPOSAL, PLANS AND/OR SPECIFICATION, ETC.</p>						

SEE REVERSE SIDE FOR TERMS AND CONDITIONS

SIGNATURE <i>Virginia L. Kline</i>	TELEPHONE (304) 755-8271	DATE 7/13/2010
TITLE Vice President	FEIN 550535003	ADDRESS CHANGES TO BE NOTED ABOVE



State of West Virginia  
 Department of Administration  
 Purchasing Division  
 2019 Washington Street East  
 Post Office Box 50130  
 Charleston, WV 25305-0130

# Request for Quotation

RFQ NUMBER
VET10112

PAGE
9

ADDRESS CORRESPONDENCE TO ATTENTION OF
BUYER 32
304-558-2544

VENDOR

RFQ COPY  
 TYPE NAME/ADDRESS HERE  
 Kanawha Stone Company, Inc.  
 401 Jacobson Drive  
 Poca, WV 25159

SHIP TO

DIVISION OF VETERANS AFFAIRS  
 ATTENTION: C. PRATHER  
 SUITE 101  
 1321 PLAZA EAST  
 CHARLESTON, WV  
 25301-1400 558-3661

DATE PRINTED	TERMS OF SALE	SHIP VIA	F.O.B.	FREIGHT TERMS
06/14/2010				

BID OPENING DATE: 07/27/2010 BID OPENING TIME 01:30PM

LINE	QUANTITY	UOP	CAT NO	ITEM NUMBER	UNIT PRICE	AMOUNT
ADDENDUM NOS.:						
NO. 1		U.P.K.				
NO. 2		U.P.K.				
NO. 3		U.P.K.				
NO. 4						
NO. 5						
I UNDERSTAND THAT FAILURE TO CONFIRM THE RECEIPT OF THE ADDENDUM(S) MAY BE CAUSE FOR REJECTION OF THE BIDS.						
VENDOR MUST CLEARLY UNDERSTAND THAT ANY VERBAL REPRESENTATION MADE OR ASSUMED TO BE MADE DURING ANY ORAL DISCUSSION HELD BETWEEN VENDOR'S REPRESENTATIVES AND ANY STATE PERSONNEL IS NOT BINDING. ONLY THE INFORMATION ISSUED IN WRITING AND ADDED TO THE SPECIFICATIONS BY AN OFFICIAL ADDENDUM IS BINDING.						
Virginia L. King, Vice President Kanawha Stone Company, Inc.				SIGNATURE		
7/13/2010				DATE		
REV. 11/96						
CONTRACTORS LICENSE						
WEST VIRGINIA STATE CODE 21-11-2 REQUIRES THAT ALL						

SIGNATURE Virginia L. King		TELEPHONE (304) 755-8271	DATE 7/13/2010
TITLE Vice President	FEIN 550535003	ADDRESS CHANGES TO BE NOTED ABOVE	

WHEN RESPONDING TO RFQ, INSERT NAME AND ADDRESS IN SPACE ABOVE LABELED 'VENDOR'



State of West Virginia  
 Department of Administration  
 Purchasing Division  
 2019 Washington Street East  
 Post Office Box 50130  
 Charleston, WV 25305-0130

# Request for Quotation

RFQ NUMBER  
**VET10112**

PAGE  
**10**

ADDRESS CORRESPONDENCE TO ATTENTION OF  
 BUYER 32  
 304-558-2544

VENDOR

RFQ COPY  
 TYPE NAME/ADDRESS HERE  
 Kanawha Stone Company, Inc.  
 401 Jacobson Drive  
 Poca, WV 25159

SHIP TO

DIVISION OF VETERANS AFFAIRS  
 ATTENTION: C. PRATHER  
 SUITE 101  
 1321 PLAZA EAST  
 CHARLESTON, WV  
 25301-1400 558-3661

DATE PRINTED	TERMS OF SALE	SHIP VIA	F.O.B.	FREIGHT TERMS
06/14/2010				

BID OPENING DATE: **07/27/2010** BID OPENING TIME: **01:30PM**

LINE	QUANTITY	UOP	CAT NO	ITEM NUMBER	UNIT PRICE	AMOUNT
------	----------	-----	--------	-------------	------------	--------

PERSONS DESIRING TO PERFORM CONTRACTING WORK IN THIS STATE MUST BE LICENSED. THE WEST VIRGINIA CONTRACTORS LICENSING BOARD IS EMPOWERED TO ISSUE THE CONTRACTORS LICENSE. APPLICATIONS FOR A CONTRACTORS LICENSE MAY BE MADE BY CONTACTING THE WEST VIRGINIA DIVISION OF LABOR CAPITOL COMPLEX, BUILDING 3, ROOM 319, CHARLESTON, WV 25305. TELEPHONE: (304) 558-7890.

WEST VIRGINIA STATE CODE 21-11-11 REQUIRES ANY PROSPECTIVE BIDDER TO INCLUDE THE CONTRACTORS LICENSE NUMBER ON THEIR BID.

BIDDER TO COMPLETE:

CONTRACTORS NAME: Kanawha Stone Company, Inc.

CONTRACTORS LICENSE NO.: WY006094

THE SUCCESSFUL BIDDER WILL BE REQUIRED TO FURNISH A COPY OF THEIR CONTRACTORS LICENSE PRIOR TO ISSUANCE OF A PURCHASE ORDER/CONTRACT

APPLICABLE LAW

THE WEST VIRGINIA STATE CODE, PURCHASING DIVISION RULES AND REGULATIONS, AND THE INFORMATION PROVIDED IN THE "REQUEST FOR QUOTATION" ISSUED BY THE PURCHASING DIVISION IS THE SOLE AUTHORITY GOVERNING THIS PROCUREMENT.

ANY INFORMATION PROVIDED IN SPECIFICATION MANUALS, OR ANY OTHER SOURCE, VERBAL OR WRITTEN, WHICH CONTRADICTS OR ALTERS THE INFORMATION PROVIDED FROM THE SOURCES AS DESCRIBED IN THE ABOVE PARAGRAPH IS VOID AND OF NO EFFECT.

SEE REVERSE SIDE FOR TERMS AND CONDITIONS

SIGNATURE <i>Virginia L. Kune</i>	TELEPHONE (304) 755-8271	DATE 7/13/2010
TITLE Vice President	FEIN 550535003	ADDRESS CHANGES TO BE NOTED ABOVE



State of West Virginia  
 Department of Administration  
 Purchasing Division  
 2019 Washington Street East  
 Post Office Box 50130  
 Charleston, WV 25305-0130

# Request for Quotation

RFQ NUMBER
VET10112

PAGE
11

ADDRESS CORRESPONDENCE TO ATTENTION OF
BUYER 32 304-558-2544

VENDOR

RFQ COPY  
 TYPE NAME/ADDRESS HERE  
 Kanawha Stone Company, Inc.  
 401 Jacobson Drive  
 Poca, WV 25159

SHIP TO

DIVISION OF VETERANS AFFAIRS  
 ATTENTION: C. PRATHER  
 SUITE 101  
 1321 PLAZA EAST  
 CHARLESTON, WV  
 25301-1400 558-3661

DATE PRINTED	TERMS OF SALE	SHIP VIA	F.O.B.	FREIGHT TERMS
06/14/2010				

BID OPENING DATE: 07/27/2010 BID OPENING TIME 01:30PM

LINE	QUANTITY	UOP	CAT NO	ITEM NUMBER	UNIT PRICE	AMOUNT
<p>BANKRUPTCY: IN THE EVENT THE VENDOR/CONTRACTOR FILES FOR BANKRUPTCY PROTECTION, THE STATE MAY DEEM THE CONTRACT NULL AND VOID, AND TERMINATE SUCH CONTRACT WITHOUT FURTHER ORDER.</p> <p>REV. 5/2009</p> <p style="text-align: center;">NOTICE</p> <p>A SIGNED BID MUST BE SUBMITTED TO:</p> <p style="text-align: center;">DEPARTMENT OF ADMINISTRATION          PURCHASING DIVISION          BUILDING 15          2019 WASHINGTON STREET, EAST          CHARLESTON, WV 25305-0130</p> <p>THE BID SHOULD CONTAIN THIS INFORMATION ON THE FACE OF THE ENVELOPE OR THE BID MAY NOT BE CONSIDERED:</p> <p>SEALED BID</p> <p>BUYER: 32</p> <p>REQ. NO.: VET10112</p> <p>BID OPENING DATE: 07/27/2010</p> <p>BID OPENING TIME: 1:30 PM</p> <p>PLEASE PROVIDE A FAX NUMBER IN CASE IT IS NECESSARY TO CONTACT YOU REGARDING YOUR BID:</p> <p style="text-align: center;">304-755-8274</p>						

SEE REVERSE SIDE FOR TERMS AND CONDITIONS			
SIGNATURE <i>Virginia L. H...</i>	TELEPHONE (304) 755-8271	DATE 7/13/2010	
TITLE Vice President	FEIN 550535003	ADDRESS CHANGES TO BE NOTED ABOVE	

WHEN RESPONDING TO RFQ, INSERT NAME AND ADDRESS IN SPACE ABOVE LABELED 'VENDOR'



State of West Virginia  
 Department of Administration  
 Purchasing Division  
 2019 Washington Street East  
 Post Office Box 50130  
 Charleston, WV 25305-0130

# Request for Quotation

RFQ NUMBER  
 VET10112

PAGE  
 12

ADDRESS CORRESPONDENCE TO ATTENTION OF  
 BUYER 32  
 304-558-2544

RFQ COPY

TYPE NAME/ADDRESS HERE

Kanawha Stone Company, Inc.  
 401 Jacobson Drive  
 Poca, WV 25159

DIVISION OF VETERANS AFFAIRS  
 ATTENTION: C. PRATHER  
 SUITE 101  
 1321 PLAZA EAST  
 CHARLESTON, WV  
 25301-1400 558-3661

DATE PRINTED	TERMS OF SALE	SHIP VIA	F.O.B	FREIGHT TERMS
06/14/2010				

BID OPENING DATE: 07/27/2010 BID OPENING TIME 01:30PM

LINE	QUANTITY	UOP	CAT NO	ITEM NUMBER	UNIT PRICE	AMOUNT
PLEASE PRINT OR TYPE NAME OF PERSON TO CONTACT CONCERNING THIS QUOTE: ----- Mike Evans -----						
***** THIS IS THE END OF RFQ VET10112 *****						TOTAL: \$11,657,154 <sup>00</sup>

SEE REVERSE SIDE FOR TERMS AND CONDITIONS

SIGNATURE <i>Virginia L. Bus</i>	TELEPHONE (304) 755-8271	DATE 7/13/2010
TITLE Vice President	FEIN 550535003	ADDRESS CHANGES TO BE NOTED ABOVE

#VET10112

**INVITATION TO BID****Donel Kinnard Memorial State Veterans Cemetery  
Charleston, West Virginia**

Sealed bids for the Donel Kinnard Memorial State Veterans Cemetery, Charleston, Kanawha County, West Virginia will be received by the State of West Virginia in accordance with the Request for Quotation issued by the Purchasing Division. The time and location for public bid opening will be given in the Request for Quotation.

Requests for Quotations may be obtained by contacting:

WV Department of Administration  
Purchasing Division  
2019 Washington Street  
Charleston, WV 25305  
Phone: 304-558-2063

A **Mandatory Prebid Meeting** will be held on a date and time stated in the Request for Quotation issued by the Purchasing Division. ATTENDANCE IS MANDATORY for interested Bidders; optional for interested sub-bidders and material suppliers. All Bidders must attend the Prebid Meeting to familiarize themselves with the Project conditions and other relevant information. Should any Bidder fail to attend, its Bid will be disqualified.

Bidders must comply with all bidding requirements and conditions set forth in the Project Manual. All bidders and bidder's subcontractors shall be licensed in compliance with the West Virginia Contractor's Licensing Act.

Bidders on this work shall also be required to comply with:

- Labor standards established by West Virginia Department of Labor.
- The Americans with Disabilities Act.

Project will be constructed under coordinated, non-concurrent multiple contracts including a General Construction and Site Work Contract and a Landscaping Contract.

**GENERAL CONSTRUCTION AND SITE WORK:**

The Contractor hereby agrees to commence work on the Project on or before a date to be specified in a written "Notice to Proceed" of the Owner. The Contractor agrees to fully complete the Project in 390 calendar days. The Contractor also agrees, for each calendar day of delay in completion of the Project beyond the stated length construction period to be liable for and pay to the Owner liquidated damages in the amount of \$750.00 per day, subject to allowances for delays beyond the control of the Contractor, all reasons for delays properly documented and verified.

**LANDSCAPING:**

The Contractor hereby agrees to commence work on the Project on or before a date to be specified in a written "Notice to Proceed" of the Owner. The Contractor agrees to fully

**INVITATION TO BID**

Page 1 of 2

**Donel Kinnard Memorial State Veterans Cemetery  
Charleston, West Virginia**

**#VET10112**

complete the Project in 90 calendar days. The Contractor also agrees, for each calendar day of delay in completion of the Project beyond the stated length construction period to be liable for and pay to the Owner liquidated damages in the amount of \$750.00 per day, subject to allowances for delays beyond the control of the Contractor, all reasons for delays properly documented and verified.

Bidding documents will be available for release on a date stated in the Request for Quotation issued by the Purchasing Division, and shall be obtained by contacting the Architect, Blackwood Associates, Inc. Project Documents may be downloaded free of charge at <http://www.wvarchitects.com/cemetery>. Hard copies will also be available for a total of **\$250.00**.

All requests for hard copies of Bidding Documents shall be made to the Architect no later than seven days prior to bid date and checks shall be received by the Architect no later than five days prior to bid date. Failure to comply with these requirements may preclude the issuance of the hard copies of Bidding Documents requested.

Bidding Documents may be examined at the following offices:

Engineer:

MSES Consultants, Inc. (MSES)  
609 West Main Street  
Clarksburg, WV 26301  
P: 304-624-9700 / F: 304-622-0981

Architect:

Blackwood Associates, Inc. (BAI)  
611 East Park Avenue  
Fairmont, WV 26554  
P: 304-366-1580 / F: 304-366-1537

Plan Houses:

A list of plan houses who have received Project Documents may be found by visiting <http://www.wvarchitects.com/Plan-Houses.pdf>

Pursuant to Chapter 21--Article 11 of the "West Virginia Contractor Licensing Act" of 1991, all Contractors doing business in West Virginia must be licensed to perform work in the State; the Contractor's W.V. License Number **must be affixed to all submitted construction Bids** and fully executed and binding construction Contracts or Agreements.

After the scheduled closing time for receipt of bids, no bid may be withdrawn for a period of ninety days. All Bidders are required to furnish a satisfactory Bid Bond in the amount of 5% of the bid price. **Please Notice: Vendor and Surety MUST affix a raised corporate seal on the Bid Bonds.**

The successful Bidder will be required to furnish satisfactory Performance and Labor and Material Payment Bonds in the amount of the contract price.

**INVITATION TO BID**

Page 2 of 2

Donel Kinnard Memorial State Veterans Cemetery  
Charleston, West Virginia

Bid Form

Donel Kinnard Memorial State Veterans Cemetery  
Charleston, West Virginia

Bid Proposal of Kanawha Stone Company, Inc.  
(hereafter called "Bidder") organized and existing under the laws of the State of West Virginia  
and doing business as

\* A Corporation  
(\*Insert "A Corporation", "A Partnership", or "An Individual")

To the West Virginia Division of Veterans Affairs (hereafter called "Owner"):

The Bidder, in compliance with your Invitation to Bid and the Request for Quotation issued by Purchasing Division of the West Virginia Department of Administration soliciting bonafide bids for the Donel Kinnard Memorial State Veterans Cemetery, Charleston, West Virginia, having examined the Bidding Documents and the site of the proposed work, and being familiar with all of the conditions surrounding the construction of the Project including the availability of materials and labor, hereby proposes to provide all labor, materials, tools and equipment necessary to complete the construction of the Project in accordance with the Bidding Documents (of which this Bid Form is a part), within the time set forth herein, and at the prices stated below.

The Bidder acknowledges receipt of the following Addenda:

1 6/14/10      2 6/15/10      3 6/30/10  
URK              URK              URK

**GENERAL CONSTRUCTION AND SITE WORK:**

The Contractor hereby agrees to commence work on the Project on or before a date to be specified in a written "Notice to Proceed" of the Owner. The Contractor agrees to fully complete the Project in 390 calendar days. The Contractor also agrees, for each calendar day of delay in completion of the Project beyond the stated length construction period to be liable for and pay to the Owner liquidated damages in the amount of \$750.00 per day, subject to allowances for delays beyond the control of the Contractor, all reasons for delays properly documented and verified.

**General Construction and Sitework - Base Bid Proposal:** The Bidder agrees to complete all Base Bid Proposal work on the Project, as required by the Bidding Documents for the following Sum:

ELEVEN MILLION, SIX HUNDRED FIFTY SEVEN THOUSAND, ONE HUNDRED FIFTY FOUR DOLLARS & ZERO CENTS (\$ 11,657,154.<sup>00</sup>)  
(Show amount in both words and figures)

In the event of a discrepancy between the wording of the Base Bid amount and the figure of the Base Bid amount, the wording shall govern.



**General Construction and Sitework - Alternate Proposals:** The Bidder agrees to perform the individual Alternate work as required by the Bidding Documents for the following Sum(s):

Alternate No. 1: Add 834 pre-placed crypts as indicated on sheet C900. This alternate includes all labor and materials for earthwork, drainage stone, underdrains, cleanouts, precast concrete crypts, backfill, irrigation, gravesite grid monuments and burial section markers. Landscaping and seeding is base bid.

SIX HUNDRED SIXTY SEVEN THOUSAND  
TWO HUNDRED DOLLARS & ZERO CENTS ADD(\$ 667,200<sup>00</sup> )  
(Show amount in both words and figures)

Alternate No. 2: Provide 4) Electric Heaters with T-stats, including all associated wiring and raceways to electric panel, in the Maintenance Building as indicated on Drawings M101M and E102M.

TWENTY FOUR THOUSAND, FOUR HUNDRED DOLLARS & ZERO CENTS, ADD(\$ 24,400<sup>00</sup> )  
(Show amount in both words and figures)

In the event of a discrepancy between the wording of the Alternate amount(s) and the figure of the Alternate amounts(s), the wording shall govern.

**General Construction and Sitework - Unit Prices:**

The Unit Prices shall determine the value of extra Work or changes in the Work, as applicable. They shall be considered complete and shall include all material and equipment, labor, installation costs, overhead, and profit. Unit prices shall be used uniformly for additions or deductions.

Unit Price No. 1 – Clearing and Grubbing: Clear and grub additional land as required to spoil additional earth.

\$ 5000<sup>00</sup> / Acre

Unit Price No. 2 – Stripping and Stockpiling Topsoil: Strip and stockpile additional topsoil from land as required to spoil additional earth.

\$ 14<sup>00</sup> / Cubic Yard

Unit Price No. 3 – Granular Fill: Provide specified gravel sub-base material, placed and compacted.

\$ 50<sup>00</sup> / Cubic Yard

FAILURE TO PROVIDE COMPLETELY FILLED-IN DATA FOR ALL OF THE ALTERNATES AND UNIT PRICES INDICATED ABOVE WILL RESULT IN THE BID BEING CONSIDERED NON-RESPONSIVE.

The Bidder understands that, depending upon the availability of funds, the Owner may, at its own discretion, accept Alternates. The Bidder further understands that it is the intent of the Owner to award a contract on the basis of lowest Base Proposal amount with or without modification by any or all of the Alternate Proposal amounts, as may solely benefit the Owner.

**LANDSCAPING:**

The Contractor hereby agrees to commence work on the Project on or before a date to be specified in a written "Notice to Proceed" of the Owner. The Contractor agrees to fully complete the Project in 90 calendar days. The Contractor also agrees, for each calendar day of delay in completion of the Project beyond the stated length construction period to be liable for and pay to the Owner liquidated damages in the amount of \$750.00 per day, subject to allowances for delays beyond the control of the Contractor, all reasons for delays properly documented and verified.

**Landscaping - Base Bid Proposal:** The Bidder agrees to complete all Base Bid Proposal work on the Project, as required by the Bidding Documents for the following Sum:

*FOUR HUNDRED SIXTY ONE THOUSAND FOUR HUNDRED FIFTY DOLLARS + ZERO CENTS* (\$ *461,450<sup>00</sup>* )  
(Show amount in both words and figures)

In the event of a discrepancy between the wording of the Base Bid amount and the figure of the Base Bid amount, the wording shall govern.

**Landscaping - Alternate Proposals:** The Bidder agrees to perform the individual Alternate work as required by the Bidding Documents for the following Sum(s):

Alternate No. L1: Provide sod as specified in LIMITED AREAS (in lieu of seed) as indicated on Planting Plan Sheets L100, L102 and L104.

*FIFTY ONE THOUSAND FIVE HUNDRED SEVENTY DOLLARS + ZERO CENTS* ADD(\$ *51,570<sup>00</sup>* )  
(Show amount in both words and figures)

Alternate No. L2: Provide sod as specified in ALL REMAINING AREAS indicated as "LAWN: GRASS MIX" on Planting Plan Sheets (L100 series). This alternate assumes that Alternate No. L1 is already accepted.

*THREE HUNDRED THIRTY EIGHT THOUSAND ONE HUNDRED DOLLARS + ZERO CENTS* ADD(\$ *338,100<sup>00</sup>* )  
(Show amount in both words and figures)

In the event of a discrepancy between the wording of the Alternate amount(s) and the figure of the Alternate amounts(s), the wording shall govern.

**Landscaping - Unit Prices:**

The Unit Prices shall determine the value of extra Work or changes in the Work, as applicable. They shall be considered complete and shall include all material and equipment, labor, installation costs, overhead, and profit. Unit prices shall be used uniformly for additions or deductions.

Unit Price No. L1 – Sod: Provide sod installed and maintained as specified.

\$ 834<sup>00</sup> / 1,000 SF

FAILURE TO PROVIDE COMPLETELY FILLED-IN DATA FOR ALL OF THE ALTERNATES AND UNIT PRICES INDICATED ABOVE WILL RESULT IN THE BID BEING CONSIDERED NON-RESPONSIVE.

The Bidder understands that, depending upon the availability of funds, the Owner may, at its own discretion, accept Alternates. The Bidder further understands that it is the intent of the Owner to award a contract on the basis of lowest Base Proposal amount with or without modification by any or all of the Alternate Proposal amounts, as may solely benefit the Owner.

---

---

The Owner agrees to authorize disbursement to the Contractor for the performance of the Contract, and to make payment on 90% of the contract sum properly allocable to labor and materials completed on the Work up to the first (1<sup>st</sup>) day of each month, less the aggregate of previous payments in each case. At the time the Work is fifty percent (50%) complete and thereafter, if the manner of completion of the Work and its progress are and remain satisfactory to the Owner and Architect, upon presentation by the Contractor of Consent of Surety, the Architect will authorize any remaining partial payments to be paid in full. Upon Substantial Completion of the Work, the payment of retainage shall be sufficient to increase the total payments to ninety-five percent (95%) for the Work designated as Substantially Complete, less any amounts as the Architect shall determine for any Work that is not complete.

The Bidder has enclosed a Bid Bond for not less than 5% of the bid proposal price indicated above.

Upon receipt of written Notice of the acceptance of this bid, the Bidder agrees to promptly furnish, within 10 calendar days of Notice, satisfactory Performance and Labor and Material Payment Bonds in the amount of the Contract Price.

---

---

Respectfully submitted for: Kanawha Stone Company, Inc.  
(Firm Name)

Contractor's WV License Number: WV006094  
(Pursuant to the WV Contractor Licensing Act 1991, 21-11-11)

By: Virginia L. King Vice President  
Virginia L. King (Signature & Title)

WV Business Registration Number: 1035-8859

Business Address: P O Box 503, Nitro WV 25143  
SEAL (If Bid is by a Corporation)



State of West Virginia  
 Department of Administration  
 Purchasing Division  
 2019 Washington Street East  
 Post Office Box 50130  
 Charleston, WV 25305-0130

# Request for Quotation

RFQ NUMBER  
**VET10112**

PAGE  
**1**

ADDRESS CORRESPONDENCE TO ATTENTION OF  
 BUYER 32  
 304-558-2544

RFQ COPY

TYPE NAME/ADDRESS HERE  
 Kanawha Stone Company, Inc.  
 401 Jacobson Drive  
 Poca, WV 25159

SHIP TO

DIVISION OF VETERANS AFFAIRS  
 ATTENTION: C. PRATHER  
 SUITE 101  
 1321 PLAZA EAST  
 CHARLESTON, WV  
 25301-1400 558-3661

DATE PRINTED	TERMS OF SALE	SHIP VIA	F.O.B.	FREIGHT TERMS
06/14/2010				

BID OPENING DATE: 07/27/2010 BID OPENING TIME 01:30PM

LINE	QUANTITY	UOP	CAT NO	ITEM NUMBER	UNIT PRICE	AMOUNT
***** ADDENDUM NO. 1 *****						
ADDENDUM ISSUED FOR THE DONEL KINNARD MEMORIAL STATE VETERANS CEMETARY CONSTRUCTION PROJECT TO CLARIFY THE MANDATORY PRE-BID DATE, AS IT WAS INCORRECTLY ADVERTISED IN THE 06/11/2010, ISSUE OF THE WEST VIRGINIA PURCHASING BULLETIN.						
THE PRE-BID DATE IS HEREBY CHANGED FROM 06/24/10 TO 06/29/2010. THE TIME AND PLACE REMAIN UNCHANGED.						
***** NO OTHER CHANGES *****						
0001	1	JB	968-42	CEMETERY GROUNDS & FACILITY CONSTRUCTION		
***** THIS IS THE END OF RFQ VET10112 *****						TOTAL: <u>14,657,154<sup>00</sup></u>

SEE REVERSE SIDE FOR TERMS AND CONDITIONS

SIGNATURE <i>Virginia S. Kue</i>	TELEPHONE (304) 755-8271	DATE 7/13/2010
TITLE Vice President	FEIN 550535003	ADDRESS CHANGES TO BE NOTED ABOVE

WHEN RESPONDING TO RFQ, INSERT NAME AND ADDRESS IN SPACE ABOVE LABELED 'VENDOR'



State of West Virginia  
 Department of Administration  
 Purchasing Division  
 2019 Washington Street East  
 Post Office Box 50130  
 Charleston, WV 25305-0130

# Request for Quotation

RFQ NUMBER  
 VET10112

PAGE  
 1

ADDRESS CORRESPONDENCE TO ATTENTION OF  
 BUYER 32  
 304-558-2544

VENDOR

RFQ COPY  
 TYPE NAME/ADDRESS HERE  
 Kanawha Stone Company, Inc.  
 401 Jacobson Drive, Poca  
 Poca, WV 25159

SHIP TO

DIVISION OF VETERANS AFFAIRS  
 ATTENTION: C. PRATHER  
 SUITE 101  
 1321 PLAZA EAST  
 CHARLESTON, WV  
 25301-1400 558-3661

DATE PRINTED	TERMS OF SALE	SHIP VIA	F.O.B.	FREIGHT TERMS
06/15/2010				

BID OPENING DATE: 07/13/2010 BID OPENING TIME 01:30PM

LINE	QUANTITY	UOP	CAT NO	ITEM NUMBER	UNIT PRICE	AMOUNT
***** ADDENDUM NO. 2. *****						
ADDENDUM ISSUED FOR THE DONEL KINNARD MEMORIAL STATE VETERANS CEMETERY CONSTRUCTION PROJECT TO CHANGE THE DATES OF THE PRE-BID MEETING AND THE BID OPENING DATE IN ORDER TO COMPLY WITH FEDERAL GRANT APPLICATION DEADLINES.						
THE PRE-BID DATE IS CHANGED FROM 06/29/10 TO 06/22/10 AT THE SAME TIME AND LOCATION.						
BID OPENING DATE IS CHANGED FROM 07/27/10 TO 07/13/10 AT 1:30 PM.						
***** NO OTHER CHANGES *****						
0001	1	JB		968-42		
CEMETERY GROUNDS & FACILITY CONSTRUCTION						

SEE REVERSE SIDE FOR TERMS AND CONDITIONS

SIGNATURE <i>Virginia R. King</i>	TELEPHONE (304) 755-8271	DATE 7/13/2010
TITLE Vice President	FEIN 550535003	ADDRESS CHANGES TO BE NOTED ABOVE



State of West Virginia  
 Department of Administration  
 Purchasing Division  
 2019 Washington Street East  
 Post Office Box 50130  
 Charleston, WV 25305-0130

# Request for Quotation

RFQ NUMBER  
**VET10112**

PAGE  
**1**

ADDRESS CORRESPONDENCE TO ATTENTION OF  
 BUYER 32  
 304-558-2544

VENDOR

RFQ COPY

TYPE NAME/ADDRESS HERE

Kanawha Stone Company, Inc.  
 401 Jacobson Drive  
 Poca, WV 25159

JUL 02 2010  
 RECEIVED

SHIP TO

DIVISION OF VETERANS AFFAIRS  
 ATTENTION: C. PRATHER  
 SUITE 101  
 1321 PLAZA EAST  
 CHARLESTON, WV  
 25301-1400 558-3661

DATE PRINTED	TERMS OF SALE	SHIP VIA	F.O.B.	FREIGHT TERMS
06/30/2010				

BID OPENING DATE: 07/13/2010 BID OPENING TIME 01:30PM

LINE	QUANTITY	UOP	CAT NO	ITEM NUMBER	UNIT PRICE	AMOUNT
***** ADDENDUM NO.3 *****						
<p>ADDENDUM ISSUED FOR THE DONEL KINNARD MEMORIAL STATE VETERANS CEMETERY CONSTRUCTION PROJECT TO DISTRIBUTE THE PRE-BID SIGN-IN SHEETS, THE BIDDING REQUIREMENTS REVISIONS, SPECIFICATION REVISIONS, REVISED DRAWINGS AS NOTED HEREIN AND DISTRIBUTED VIA SEPARATE COVER BY THE ARCHITECT, THE PRE-BID MEETING MINUTES, VENDOR SUBMITTED Q/A RECEIVED PRIOR TO THE 06/25/10 CUT-OFF, THE PACKAGE WASTEWATER TREATMENT SYSTEM SPECIFICATIONS, AND THE REVISED BID SCHEDULES AS A RESULT OF THE MANDATORY ONSITE PRE-BID MEETING ON 06/22/2010.</p> <p>TO FURTHER CLARIFY, THIS PROJECT REQUIRES SUBMISSION OF TWO (2) BIDS AND WILL RESULT IN THE AWARD OF TWO (2) CONTRACTS.</p> <p>VENDORS MAY BID ON THE CONSTRUCTION &amp; SITE WORK, THE LANDSCAPING BID, OR BOTH. PLEASE BE ADVISED THAT EACH BID WILL REQUIRE A SEPARATE BID SECURITY (BOND) FOR 5% OF THE AMOUNT OF THE INDIVIDUAL BID. VENDORS BIDDING BOTH PORIONS WILL NOT BE ALLOWED TO SUBMIT ONE BID BOND TO COVER BOTH BIDS. VENDORS WHO DO SO WILL HAVE THEIR BIDS DISQUALIFIED. CONSEQUENTLY, THE SEPARATE CONTRACTS WILL REQUIRE SEPARATE PERFORMANCE AND LABOR/MATERIAL BONDS BE SUBMITTED IF ONE VENDOR IS RECOMMENDED FOR THE AWARDS.</p> <p>BID OPENING DATE &amp; TIME REMAIN UNCHANGED AS 07/13/10 AT 1:30 PM.</p> <p>***** NO OTHER CHANGES *****</p>						

SEE REVERSE SIDE FOR TERMS AND CONDITIONS

SIGNATURE *Virginia S. King* TELEPHONE (304) 755-8271 DATE 7/13/2010

TITLE Vice President PEIN 550535003 ADDRESS CHANGES TO BE NOTED ABOVE

**Pre-Bid Conference  
SIGN IN SHEET**  
(Please print legibly)

Request for Proposal No: YET10112

Date: 6.22.2010

<u>Representative &amp; Firm Name</u>	<u>Mailing Address</u>	<u>Telephone &amp; Fax Number</u> <u>Email Address</u>
EX: _____ Chuck Bowman WV State Purchasing Division	PO Box 50130 2019 Washington Street, East Charleston, WV 25305	T: 304-558-2157 F: 304-558-4115 Email: cbowman@wvadmin.gov
1. <u>NATHAN B. SICK</u> <u>FRONTIER CONST. CO., INC.</u>	<u>RT 31-E</u> <u>PO BOX 84</u> <u>JONES MILLS, PA 15046</u>	T: <u>724-593-7491</u> F: <u>724-593-7499</u> Email: <u>n.sicke@frontierconcrete.com</u>
2. <u>John G. Egan</u> <u>CHAPMAN-MARTIN EXCAVATION</u> <u>GRADING, INC.</u>	<u>P.O. BOX 9385</u> <u>5151 JAMES RIVER RD.</u> <u>NEWARK, WV 25704</u>	T: <u>304-429-2434</u> F: <u>304-429-8235</u> Email: <u>jhinkle2434@aol.com</u>
3. <u>CHRIS SHAW</u> <u>PARAMOUNT BUILDERS LLC</u>	<u>501 6TH AVE</u> <u>St. Albans WV 25177</u>	T: <u>304-727 2770</u> F: <u>304-727 0302</u> Email: <u>cshaw@paramountwv.com</u>
4. <u>Joni Winkler</u> <u>Rhodes Brick &amp; Block</u>	<u>10 Winfield Rd</u> <u>St. Albans, WV</u> <u>25177</u>	T: <u>304-727-7062</u> F: <u>304-<del>558-722</del> 722-1822</u> Email: <u>Joni@rhodesblock.com</u>
5. <u>Robert Morris</u> <u>Rhodes Brick &amp; Block Co</u>	<u>10 winfield rd</u> <u>St ALBANS WV 25177</u>	T: <u>304 549-7062</u> F: <u>304 722-1822</u> Email: <u>Sales@rhodesblock.com</u>
6. <u>Mike Lyons</u> <u>WV DVE</u>	<u>1321 Plaza East Suite 109</u> <u>Charleston, WV 25301</u>	T: <u>(304) 558-3661</u> F: <u>(304) 380-5215</u> Email: <u>Mike.C.Lyons@wv.gov</u>
7. <u>DAVE KIRILIA</u> <u>INDEPENDENCE EXCAVATING</u>	<u>5720 Schaefer Rd</u> <u>INDEPENDENCE OHIO</u> <u>44131</u>	T: <u>216-446-3582</u> F: <u>216 446-3583</u> Email: <u>wjw@indec.com</u>
8. <u>UDAN HAZELETT</u> <u>VET STUDY</u>	<u>12661 C.Millicathe Rd</u> <u>CHESTERLAND OHIO</u> <u>44026</u>	T: <u>440-688-4212</u> F: <u>440-688-4215</u> Email: _____
9. <u>TIM CUNNINGHAM</u> <u>Savage Heavy Lwy</u>	<u>196 PETERS RUN RD</u> <u>WHEELING, WV 26003</u>	T: <u>304-242-3100</u> F: <u>304-242-3104</u> Email: <u>TCUNNINGHAM@SAVHHO.COM</u>



**Pre-Bid Conference**  
**SIGN IN SHEET**  
 (Please print legibly)

Request for Proposal No: VET 10112

Date: 6.22.2010

<u>Representative &amp; Firm Name</u>	<u>Mailing Address</u>	<u>Telephone &amp; Fax Number</u> <u>Email Address</u>
EX: _____ Chuck Bowman WV State Purchasing Division	PO Box 50130 2019 Washington Street, East Charleston, WV 25305	T: 304-558-2157 F: 304-558-4115 Email: cbowman@wvadmin.gov
1. Robert Turcic MASSARO Corp.	120 Delta Dr. Pittsburgh PA. 15238	T: 412-963-2800 F: 412-963-2880 Email: JWells@MASSARO CORPORATION.C
2. Danhill Const. Co Robert D. Hill	P.O. Box 685 Gawley Bridge, WV 25085	T: 304-632-1600 F: 304-632-1501 Email: rdanhill@hotmail.com
3. Robert Connelly ACF Environmental	50 Winfield Rd ST Albans WV 25177	T: 540-438-1423 F: 540-438-0533 Email: RConnelly@ACFENVIRONMENTAL.CO
4. Wilson Wright JDE Inc.	200 GCP Road WHEELING, WV 26003	T: 304.232.5000 F: 304.232.0619 Email: marks@jde-inc.com
5. DANHILL CONSTRUCTION MICHAEL SIEMIACZKO JR	PO Box 685 GAULEY BRIDGE WV 25085	T: 304-632-1600 F: 304-632-1501 Email: PollockinWV@hotmail.com
6. HOWARD WINTERS PER DAVID LAWMAN KANAWHA STONE COMPANY	401 JACOBSON DRIVE FOCA, WV 25159	T: 304-755-8271 X 303 F: 304-755-8274 Email: <del>lawnman</del> DAVID.LAWMAN@KANAWHASTONE.CO
7. _____	_____	T: _____ F: _____ Email: _____
8. _____	_____	T: _____ F: _____ Email: _____
9. _____	_____	T: _____ F: _____ Email: _____

**Pre-Bid Conference  
SIGN IN SHEET**  
(Please print legibly)

Request for Proposal No: VET 10112Date: 6/22/2010

<u>Representative &amp; Firm Name</u>	<u>Mailing Address</u>	<u>Telephone &amp; Fax Number Email Address</u>
EX: _____ Chuck Bowman WV State Purchasing Division	PO Box 50130 2019 Washington Street, East Charleston, WV 25305	T: 304-558-2157 F: 304-558-4115 Email: cbowman@wvadmin.gov
1. <u>Lisa Stalaker</u> <u>Jarrett Construction</u>	<u>PO Box 5050</u> <u>1105 Virginia St. E</u> <u>Charleston WV 25361</u>	T: <u>344-9140</u> F: <u>344-9143</u> Email: <u>lisa.stalaker@jarrett-construction.com</u>
2. <u>Jim Carney</u> <u>OVAL CONSTRUCTION</u>	<u>PO Box 401</u> <u>CHARLESTON, WV 25322</u>	T: <u>347-8820</u> F: <u>347-8821</u> Email: <u>jcarney@ovalconstruction.com</u>
3. <u>TODD COREY</u> <u>BBL CARLTON, LLC</u>	<u>900 LEE STREET</u> <u>SUITE 1400</u> <u>CHARLESTON, WV 25301</u>	T: <u>tc Corey@bblcarlton.com</u> F: <u>304-345-1304</u> Email: <u>304.345.1300</u>
4. <u>CHAD EARL</u> <u>CONTECH Construction</u> <u>Products, INC.</u>	<u>1117 OAKMONT Rd.</u> <u>CHARLESTON, WV</u> <u>25314</u>	T: <u>304-998-1097</u> F: _____ Email: <u>earlc@CONTECH-CPI.com</u>
5. <u>Kerry Cole</u> <u>Foster Supply</u>	<u>4847 Teays Valley Rd</u> <u>Scott Depot, WV</u> <u>25560</u>	T: <u>304-755-8241</u> F: _____ Email: <u>KerryCole@fostersupply.com</u>
6. <u>Billy Malashevich</u> <u>Peerless Block &amp; Brick</u>	<u>400 Olive St</u> <u>St Albans, WV</u> <u>25177</u>	T: <u>304-241-1128</u> F: <u>304-727-4306</u> Email: <u>Billy.Malashevich@peerlessblock.com</u>
7. <u>DAN ZACCAGNINI</u> <u>AQUILA STONE</u>	<u>271 DON KNOTTS BLVD</u> <u>MORLANTOWN, WV</u> <u>26505</u>	T: <u>304-288-5443</u> F: <u>304-292-7961</u> Email: <u>DAN@AQUILASTONE.COM</u>
8. <u>Michael Hubbard</u> <u>Branch &amp; Associates</u>	<u>5742 Airport Rd</u> <u>Roanoke, VA</u> <u>24012</u>	T: <u>540-989-5215</u> F: <u>540-989-0883</u> Email: <u>tonyb@branch-associates.com</u> <u>michaelh@branch-associates.com</u>
9. _____	_____	T: _____ F: _____ Email: _____

**Pre-Bid Conference**  
**SIGN IN SHEET**  
(Please print legibly)

Request for Proposal No: VET10112

Date: 6.22.2010

<u>Representative &amp; Firm Name</u>	<u>Mailing Address</u>	<u>Telephone &amp; Fax Number</u> <u>Email Address</u>
---------------------------------------	------------------------	---

EX: _____ Chuck Bowman WV State Purchasing Division	PO Box 50130 2019 Washington Street, East Charleston, WV 25305	T: 304-558-2157 F: 304-558-4115 Email: cbowman@wvadmin.gov
---	--	--

1. <u>Jill Blackwood</u> <del>BLACKWOOD ARCHITECTS</del>	<u>611 EAST PARKWAY</u> <u>FAIRMONT, WV</u> <u>26554</u>	T: <u>304-366-1580</u> F: <u>304-366-1537</u> Email: <u>JWB@WVARCHITECTS.CE</u>
---	--	---

2. <u>KENTON BLACKWOOD</u> <u>(BAI)</u>	<u>(SAME ↑)</u>	T: _____ F: _____ Email: <u>Kenton@WVarchitects.com</u>
--	-----------------	---

3. <u>JEFF WISE</u> <u>MSES /</u> <u>BAI</u>	<u>(SAME ↑)</u>	T: <u>304 366-1580</u> F: _____ Email: <u>wise@mSESinc.com</u>
--	-----------------	--

4. <u>Darrell Mechl</u> <u>The LA Group</u>	<u>40 Long Alley</u> <u>Saratoga Springs,</u> <u>NY 12866</u>	T: <u>518-587-8100</u> F: <u>518-587-0180</u> Email: <u>dmechl@thelagroup.com</u>
--	---	---

5. _____	_____	T: _____ F: _____ Email: _____
----------	-------	--------------------------------------

6. _____	_____	T: _____ F: _____ Email: _____
----------	-------	--------------------------------------

7. _____	_____	T: _____ F: _____ Email: _____
----------	-------	--------------------------------------

8. _____	_____	T: _____ F: _____ Email: _____
----------	-------	--------------------------------------

9. _____	_____	T: _____ F: _____ Email: _____
----------	-------	--------------------------------------

**ADDENDUM NO. 3 - June 29, 2010**

**PROJECT:** Donel Kinnard Memorial State Veterans Cemetery  
 Charleston, West Virginia  
 FAI# WV-08-01

**TO:** Prospective Bidders

**FROM:** Blackwood Associates, Inc., Architect, Fairmont, WV

This Addendum forms a part of the Contract Documents and modifies the original Bidding Documents dated May 20, 2010 and any subsequent addenda. Acknowledge receipt of this Addendum in the space provided on the Bid Form. Failure to do so may subject the Bidder to disqualification.

This Addendum includes the Addendum Items (3 pages), Pre-Bid Meeting Notes (3 pages), Contractor's Questions and Answers (3 pages), Specification Section 333100 (12 pages) and five (5) full-size Drawings (issued under separate cover).

A Mandatory Pre-Bid Meeting was held at the West Virginia State Police Academy, 135 Academy Drive, Dunbar, WV 25064 on June 22, 2010 at 10:00 a.m. The Meeting Notes and Attendance List are attached to this Addendum.

**CHANGES TO PRIOR ADDENDA:** Not applicable to this Addendum.

**CHANGES TO BIDDING REQUIREMENTS:** Not applicable to this Addendum.

**Invitation to Bid**

**Page 1,**

1. Under **GENERAL CONSTRUCTION AND SITE WORK:**  
**REVISE** first sentence to read as follows:  
 "The Contractor hereby agrees to commence work on the Project on or after a date to be specified in a written "Notice to Proceed" of the Owner."
2. Under **LANDSCAPING:**  
**REVISE** the first sentence to read as follows:  
 "The Contractor hereby agrees to commence work on the Project on or after a date to be specified in a written "Notice to Proceed" of the Owner."
3. **State of West Virginia Supplementary Instructions to Bidders for AIA Document A701-1997:  
 Page 1, Article 3, Paragraph 4.4.1.1**
4. **REVISE** to read as follows:  
 "Bids may not be modified or withdrawn for a period of 90 days."
5. **Amendments to AIA Document A701 "Instruction to Bidders"  
 Page 1,**  
**REVISE** as follows:  
 "Page 5, Article 4, Paragraph 4.3.2: **REVISE** second sentence to read as follows: "Bids received after the time and date for receipt of Bids will be opened, stamped and maintained on file by Owner."

**List of Proposed Subcontractors and Equipment/Materials Suppliers**

**Before the first sentence:**

6. **ADD** the following:  
"Within two (2) hours after the schedule Bid Opening the apparent low bidder - as indicated by the Architect via the Project Website ([www.wvarchitects.com/cemetery](http://www.wvarchitects.com/cemetery)) - shall submit this completed form to the Owner and Architect via facsimile or electronic mail for review and consideration."
7. **OMIT** in its entirety the last sentence which reads: "Any change of proposed..... for execution of the work."
8. **WV-96 – Agreement Addendum**  
**OMIT** in its entirety.

**CHANGES TO CONDITIONS OF THE CONTRACT:** Not applicable to this Addendum.

**CHANGES TO SPECIFICATIONS:**

9. **Specification Section 013300 "SUBMITTAL PROCEDURES"**  
**Page 2, Paragraph 1.4.A**  
**REVISE** to read as follows:  
"Architect's Digital Data Files: Electronic copies of digital data files of the Contract Documents will be provided by Architect for Contractor's use in preparing submittals."
10. **Specification Section 015000 "TEMPORARY FACILITIES"**  
**Page 8, Paragraph 3.4.G.1**  
**OMIT:** "and as indicated on Drawings."
- Specification Section 042000 "UNIT MASONRY"**
11. **Page 3, Paragraph 2.2.C.1**  
**ADD** subparagraph 'e' to read as follows: "e. Axim Italcementi Group; Intrapel XS."
12. **Page 4, Paragraph 2.4.C.1**  
**ADD** subparagraph 'a' to read as follows: "a. Statesville Brick - Red Royal."
13. **Page 6, Paragraph 2.5.G.1.b.3**  
**REVISE** to read as follows: "Essroc; Italcementi Group; Intrapel Flamingo Brixment."
14. **Specification Section 044300 "MANUFACTURED STONE MASONRY VENEER"**  
**Page 5, Paragraph 2.1.A.**  
**ADD** subparagraph 4 to read as follows: "4. Glen-Gery Landmark Stone."
15. **Specification Section 271100 "COMMUNICATIONS EQUIPMENT ROOM FITTINGS"**  
**OMIT** in its entirety.
16. **Specification Section 271300 "COMMUNICATIONS BACKBONE CABLING"**  
**OMIT** in its entirety.
17. **Specification Section 280513 "CONDUCTORS AND CABLES FOR ELECTRONIC SAFETY AND SECURITY"**  
**OMIT** in its entirety.

- Specification Section 323223 "SEGMENTAL RETAINING WALLS"**
18. **Page 1, Paragraph 1.4.A.2**  
**REVISE** last sentence to read as follows: "The Manufacturer's Design Engineer shall submit the signed and sealed design calculations for the installation for review and approval during the submittal process."
19. **Page 2, Paragraph 2.1.A**  
**REVISE** the last sentence to read as follows: "The manufacturer of the retaining wall system shall provide engineering designs and calculations for the wall system, prepared and sealed by a licensed Professional Engineer, suitable for the project site conditions and meeting all State, Local and Federal Building code requirements."
20. **Specification Section 329000 "PLANTING"**  
**Page 1, Paragraph 1.3**  
**OMIT** the words "(BY OTHERS)" from the title.
21. **Specification Section 333100 "PACKAGE WASTEWATER TREATMENT SYSTEM"**  
**ADD** Section as attached to this Addendum.

**CHANGES TO DRAWINGS:**

22. **Drawings E&S 100, E&S 101, E&S 102, E&S 103 and E&S 104**  
**OMIT** Drawings in their entirety and **REPLACE** with **Drawings E&S 100~A3.1, E&S 101~A3.2, E&S 102~A3.3, E&S 103~A3.4 and E&S 104~A3.5** as attached to this Addendum (to be sent under separate cover).

**Drawing C104 "STORM DRAINAGE- AREA 3"**  
**Drainage Structures Table C104**  
**Structure # DI-74**

23. **REVISE** Bott. Elev. To 619.00  
 24. **REVISE** Elev. In from DI-75 to 620.00  
 25. **REVISE** Inv. Elev. Out to 620.00  
 26. **REVISE** Slope to 0.033  
**Structure #DI-75**  
 27. **REVISE** Rim Elev. To **622.75**  
 28. **REVISE** Bott. Elev. To 619.25  
 29. **REVISE** Inv. Elev. Out to 620.25  
 30. **REVISE** Slope to 0.042

**Drawings L100, L101, L102, L103, L104, and L105**

31. **REVISE** all references made to **ADD ALT. No. 2** to "**ADD ALT. No. L1**".  
 32. **REVISE** all references made to **ADD ALT. No. 3** to "**ADD ALT. No. L2**".

**Drawings L100, L102 and L104**

33. **REVISE** all references made to **ADD ALT. No. 3** to "**ADD ALT. No. L2**".  
 34. **REVISE** all references made to **ADD ALT. No. 2** to "**ADD ALT. No. L1**".

END OF ADDENDUM NO. 3

**Donel Kinnard Memorial State Veterans Cemetery  
Charleston, West Virginia  
Pre-Bid Meeting – June 22; 10:00 a.m.**

1. This meeting is mandatory for Bidders. Failure to attend this Mandatory Pre-Bid Meeting shall result in disqualification of the Bid. No one person may represent more than one Bidder. An attendance sheet is available for all potential Bidders to complete. This will serve as the official document verifying attendance. Failure to provide company and representative name on the attendance sheet will result in disqualification of the Bid. Please include e-mail address and fax number.
2. Owner and A/E Representatives  
Chuck Bowman, WV Purchasing Div.  
Keith Gwinn, WV Division of Veterans Affairs  
Jim Blackwood, Blackwood Associates, Inc.  
Kenton Blackwood, Blackwood Associates, Inc.  
Jeff Wise, MSES consultants, inc.  
Darrell Meehl, LA Group, PC.
3. Bidding Documents are available from the Architect. Bidding documents may be downloaded free of charge at <http://www.wvarchitects.com/cemetery/>. Hard copies are also available for a total of **\$250.00 (non-refundable)**. All requests for hard copies of Bidding Documents must be received no later than seven days prior to Bid Date.
4. Bids will be received by the State of West Virginia in accordance with the Request for Quotation issued by the Purchasing Division. **Bid Opening: July 13, 2010; 1:30 PM.**
5. Request for Quotation may be obtained by contacting: WV Department of Administration, Purchasing Division, 2019 Washington Street, Charleston, WV 25305; Phone: 304-558-2063.
6. Bids shall be submitted on the **Bid Form** included in the Bidding Documents. **Each Bidder should obtain a Request for Bids/Quotations from the Purchasing Division and must follow all instructions contained therein. The Request for Bids/Quotations should be stapled to the front of the Bid Form. Each Bid shall be enclosed in a sealed, self addressed, opaque envelope plainly marked with the information shown.**
7. All bidders and bidder's subcontractors must be licensed in compliance with the **West Virginia Contractors Licensing Act**. Bidders shall also be required to comply with **Labor standards established by West Virginia Department of Labor and the Americans with Disabilities Act**.
8. West Virginia Code §21-11-11 requires Bidders to include the Bidder's contractor's license number on its Bid. The successful Bidder shall furnish a copy of its contractor's license prior to issuance of a Purchase Order/Contract.
9. Bid Bond in the amount of five percent (5%) of the total amount of the Bid payable to the State of West Virginia must be submitted with each Bid.

10. Bidders must submit a valid Drug Free Workplace Conformance Affidavit with each bid. Vendors must also submit a Purchasing Affidavit for each bid prior to the award. These documents are included in the Request for Quotation issued by the Purchasing Division.
11. Bidders must acknowledge receipt of Addenda on the Bid Form or Bid may be rejected.
12. Bids may not be modified or withdrawn for a period of **ninety (90) days** after receipt of Bids without forfeiture of Bid security, not as a penalty but as liquidated damages.
13. The successful bidder shall furnish a Performance Bond and a Labor and Material Payment Bond for 100% of the contract award, as well as a Maintenance Bond covering the roof system for two years in an amount equal to the cost of the roof system. The successful Bidder shall deliver the required bonds and all other Contract Documents, including Certificates of Insurance, within fifteen (15) days after receipt of the Owner's letter of intent to award a Contract or forfeit the security deposited with his Bid as liquidated damages, not as a penalty. **These bonds shall be written on the State of West Virginia forms bound in the Project Manual and according to the instructions provided with these forms.**
14. Project will be constructed under coordinated, non-concurrent multiple contracts including a General Construction and Site Work Contract and a Landscaping Contract. Bidders may bid either and/or both Contracts. The bid prices will be considered separately.
15. Notice to Proceed: Unless otherwise specified, the fully executed Purchase Order will be considered notice to proceed. The General Construction and Site Work Contract is to be performed within 390 calendar days after the Notice to Proceed is received. The Landscaping Contract is to be performed within 90 calendar days after the Notice to Proceed is received
16. Prior to any award, the apparent successful vendor must be properly registered with the Purchasing Division and have paid the required \$125.00 fee.
17. Liquidated Damages: The successful Bidder shall also agree, for each calendar day of delay in completion of the Project beyond the stated length construction period to be liable for and pay to the Owner **liquidated damages in the amount of \$750.00** per day, subject to allowances for delays beyond the control of the Contractor, all reasons for delays properly documented and verified.
18. Wage Rates: The successful Bidder and all Subcontractors shall pay the higher of the U.S. Department of Labor minimum wage rates or the West Virginia Department of Labor wage rates as established for Kanawha County. Contractor(s) shall be responsible for obtaining the most current information. Certified payrolls shall be submitted to the Owner with each Application for Payment.
19. Successful Bidder is required to provide a certificate from Workers' Compensation.
20. Successful Bidder shall furnish proof of commercial general liability insurance prior to issuance of contract.



21. The following items in Specification Section 011000, "Summary":

- 1) Scope of Work
- 2) Concurrent Work
- 3) Use of Premises
- 4) Owner's Occupancy Requirements
- 5) Work Restrictions

22. Addenda will be issued by the Purchasing Department.

Donel Kinnard Memorial State Veterans Cemetery  
 Pre-Bid Meeting  
 Contractors Questions and Answers

1. Q: Is specification Section 328400, Planting Irrigation included with the Landscaping Bid?  
 A: Irrigation is part of the General Construction and Site Work contract.
2. Q: Start Date – What is the anticipated start dates for the General Construction and Site Work and Landscaping contracts?  
 A: Specific start dates for each Contract have not been established, but it is anticipated, subject to approval by State agencies and federal funding source, the General Construction and Sitework Contract will commence within approximately ninety days after the Bid opening. The Landscape Contract will commence upon substantial completion of the General Construction and Sitework Contract.
3. Q: Wages – We currently have to bid the wages for 2010 because the rates for 2011 will not be available till January of 2011. Will compensation be provided for the increase in wages for 2011? The wages typically increase 5% each year.  
 A: Bid according to applicable prevailing wage rates. There is no allowance or provision for wage increases.
4. Q: Materials – Is there any provisions in the agreement for any material escalations cost increase during the life of the project?  
 A: No.
5. Q: Fuel – Can fuel index be provided for the project to protect the contractor from fuel fluctuations?  
 A: No.
6. Q: Bid Delivery – Are bids permitted to be submitted by fax per the Amendments to AIA Document A701"Instructions to Bidders", Page 1 of 1 (Page 5, Article 4, Paragraph 4.3.4)?  
 A: Yes.
7. Q: Township Fees – What township fees will be required?  
 A: There is no township. Bidders are responsible for determining applicable county inspection fees and other similar costs.
8. Q: MBE/WBE – Are there percentage goal requirement for Minority or Women Business Enterprises?  
 A: No.
9. Q: Tax Status – Can you confirm that the project will be exempt from Federal, State and local taxes per item 4 on WV-96, Rev. 10/07 Agreement Addendum?  
 A: Project is not exempt from taxes. Addendum No. 3 omits WV-96 – Agreement Addendum.
10. Q: Bid Forms – If only bidding one of the contracts do we simply insert "NO BID" for the contract we are not bidding?  
 A: Insert "NO BID" or leave blank.

11. Q: Are we still to insert the price on page 1 of the RFQ if only bidding one contract?  
A: No. Indicate Bid price(s) on Bid Form.
12. Q: Subcontractors – Are we required to submit the “List of Proposed Subcontractors and Equipment / Materials Suppliers” form, Pages 1 to 4 with our bid?  
A: Addendum #3 adds the requirement that the apparent low bidder shall submit “List of Proposed Subcontractors and Equipment / Materials Suppliers” to the Architect and Owner within 2 hours after the scheduled opening of bids for review and consideration. The Architects website ([www.wvarchitects.com/cemetery](http://www.wvarchitects.com/cemetery)) will provide the name of the apparent low bidder within approximately 30 minutes after completion of the opening of bids. Refer to AIA Document A701 “Instructions to Bidders” Article 6.3.3 for further information.
13. Q: Landscaping Bid – Can you confirm that only the following work is to be included under the Landscaping Bid and the remainder of the work is to complete the project will fall under the General Construction and Site Work Bid?  
A. Maintenance of previously installed erosion and sediment controls  
B. Topsoil testing  
C. Soil amendments and conditioning (organic soil amendment)  
D. Supplemental Topsoil  
E. Landscaping (L100 to L106)  
F. Turfs and grasses (except steep slope grassing) (L100 to L106)  
G. Removal of all erosion and sediment controls.  
A: All work, requirements and warranties, as noted in Specification Section 329000, with the exception of the work related to the steep slope area seeding, establishment and maintenance, is the responsibility of the Landscape Contractor. “Steep Slope Areas” are designated on the Landscaping series of Plans. Refer to Section 011200 for additional information as to what is required of each Contract. Also, referring to Section 329000, paragraph 1.3, the words “(BY OTHERS)” will be removed in this addendum. The Landscape Contractor will be required to follow the testing procedures established in Section 014529, TESTING LABORATORY SERVICES, as well as maintaining the erosion and sedimentation control devices installed by the General Construction Contractor as described in Section 015719, TEMPORARY ENVIRONMENTAL CONTROLS. The Landscape Contractor will also be required to remove the erosion and sedimentation control devices when site conditions are stabilized as specific in Section 015719, TEMPORARY ENVIRONMENTAL CONTROLS.
14. Q: Site Enclosure Fence – Is there a plan that denotes the location of the Site Enclosure Fence locations?  
A: Location and extent of temporary construction fence is not indicated on the Drawings and is left to the Bidder's discretion as per Section 015000 “TEMPORARY FACILITIES AND CONTROLS.” Addendum No. 3 removes the reference to fencing being indicated on Drawings.
15. Q: Burning – Can you confirm that burning of cleared timber will be permitted per 017419-7, 3.6, C?  
A: Burning will be permitted as noted in Section referenced, i.e., “only in designated areas on Owner’s property, provided required permits are obtained”, from the local authority having jurisdiction. In addition, “Provide full time monitoring for burning materials until fires are extinguished.” **NOTE:** West Virginia has regular designated “no-burn” seasons, and additional no-burn periods dependent on rainfall.

16. Q: Rock Removal – If rock would be encountered will the contractor be compensated by change order?  
A: “*The Report of Geotechnical Exploration & Engineering Analysis, Donel Kinnard Memorial Veterans Cemetery*”, dated February, 2010, and Addendum #1 to the Report, dated April 29, 2010, as provided in Project Manual just preceding Section 312000 – EARTHMOVING, contains Logs of Test Borings, Test Boring Locations, and analysis of the site. In addition the test boring locations are shown on Drawings G100 through G106, Grading Plan.

The contractor’s base bid shall include the excavation for the roadway, building structures, drainage structures, channel changes, and all other excavation required for the completed project, including the removal and hauling of all material, of whatever character encountered, not being removed under some other item. This will be done in reasonably close conformity with the lines, grades, thicknesses and cross sections shown on the Plans.

The contractor will not be compensated by change order for this item.

17. Q: Irrigation – Is there a state license to install irrigation in the state of WV beyond the general contractor licenses?  
A: The General Construction Contractor will need to make his own determination as to whether a separate license (in addition to the General Contractor’s license) is required to install irrigation systems in the state of WV.
18. Q: Wetlands – can you confirm that there are no on-site wetlands?  
A: There are no on-site wetlands.

SPECIFICATIONS  
FOR  
PACKAGE WASTEWATER TREATMENT SYSTEM  
VA STATE CEMETERY  
INSTITUTE, WEST VIRGINIA

The new West Virginia State Veterans' Cemetery, to be constructed near Institute, West Virginia, will have minimum sanitary wastewater generation. Since there is no local sanitary sewer service, it will be necessary to install a small septic/filter system for treatment of sanitary wastewater.

An ASHCO RFS III system or equivalent will be installed for sanitary wastewater treatment. The following pages contain the specifications for an RFS III system of 600 GPD.

The Contractor will be responsible for purchase, installation and startup of the system. In addition, the Contractor will provide equipment specific preventive maintenance procedures/schedule, inspection procedures/schedule and a list of replacement parts to be maintained by the State VA. This information shall be submitted in O&M Manuals (3 copies) to be given to the Owner upon closure of the project. Provide with O&M Manuals operational procedures under various conditions, describing alarm situations and a manufacturer's contact to call. The treatment plant manufacturer or Contractor must jointly enter into a five-year maintenance contract with the Owner as required by the State of West Virginia DEP.

**WEST VIRGINIA STANDARD  
RFS<sup>III</sup> Pat. No. 6,287,469  
SPECIFICATIONS**

**PRIMARY PROCESS DESCRIPTION**

Wastewater flows by gravity from the home to the septic tank. Inside the septic tank, which is situated as close to the waste producing source as possible, the settleable solids fall to the bottom of the tank where they decompose anaerobically to form a sludge layer. The lighter less dense material mainly composed of fats, oils, and greases floats to the top of the water and creates a scum layer. Effluent from the relatively clear zone of the septic tank, between the scum and the sludge layers, enters the effluent filter through inlet holes. Effluent then enters the annular space between the housing and the filter tubes. Particles larger than 1/8" are detained in the annular space, where decomposition of the organic material occurs.

**RFS<sup>III</sup> TREATMENT.**

The filtered septic tank effluent then flows by gravity to the recirculation tank bottom zone. The recirculation pump in the bottom zone pumps the effluent via a spray grid onto a sand filter. The effluent trickles down the filtrate media where it is treated by naturally occurring micro-organisms populating the sand filter. After passing through the biological filter media, the treated effluent is stored in the bottom zone where it is mixed with incoming septic tank effluent. The mixing of septic tank effluent with biologically filtered effluent creates a dilute waste to be recirculated through the sand filter. The treated effluent is discharged either by gravity or a small discharge pump to disinfection and/or discharge.

**DESIGN SPECIFICATIONS AND PLANT LOADING RATES**

Sand Filter Surface Area.....120-140 Ft.<sup>2</sup> Range

Loading Rate (4 Bdrm. Home).....	600 GPD/120 Ft. <sup>2</sup>
(4 Bdrm. X 150 GPD)	= 5.0 GPD/Ft. <sup>2</sup>
	600 GPD/140 Ft. <sup>2</sup>
	= 4.3 GPD/Ft. <sup>2</sup>

NOTE: 5.0 GPD/Ft.<sup>2</sup> of filter area is the maximum hydraulic loading rate for the RFS<sup>III</sup> Recirculating Sand Filter.

SEPTIC TANK SPECIFICATIONS

Max. Liquid Capacity @	1,000 Gallons
Min. Wall Thickness @	2 ½"
Max. Wall Thickness @	3"
Min. Top & Bottom Thickness @	4"
Max. Top & Bottom Thickness @	4 ½"
Access.....	Minimum 21" access riser opening with lid above inlet and outlet.
Effluent Filter.....	OSI Model FT 0444-36 or approved equal. (See Spec. Sheet)

RFS III TECHNICAL SPECIFICATIONS

Pre-Cast Concrete Tank:

Surface area provided shall be equal to 60-70 Ft<sup>2</sup> per tank.

Width of tank shall be no less than 5 feet and no greater than 6 feet.

Minimum wall thickness shall be no less than 2 ½" and no greater than 3".

Minimum top and bottom thickness shall be no less than 4" and no greater than 4 ½".

Inside tank height shall be no less than 4'6" and no greater than 5'6".

Tank type shall be top seal, but if not available, mid seal tank designs will be considered.

All tank pipe connectors shall be constructed of poly-isoprene or rubber to ensure a flexible watertight seal.

### FILTER MEDIA SPECIFICATIONS

Sand filter media shall conform to wastewater treatment media requirements to be hard, durable, and free of organic matter. Filter media shall be Black Beauty® (product grade #1040 or manufacturer approved equal with the following physical properties:

Effective Size.....	1.00 mm to 1.70 mm
Uniformity Coefficient.....	Less than 1.90
Particle Shape.....	Angular Shape
Hardness.....	6-7 on MOH Scale
Bulk Density.....	75-100 lbs./ Ft <sup>3</sup>
Specific Gravity.....	2.73
Moisture Content.....	Less than 0.5%
Free Silca.....	Less than 1.0%

### CHEMICAL ANALYSIS

Silicon Dioxide.....	48.78%
Aluminum Oxide.....	20.97%
Titanium Dioxide.....	0.94%
Ferric Oxide.....	19.08%
Calcium Oxide.....	6.02%
Magnesium Oxide.....	0.95%
Potassium Oxide.....	1.67%
Sodium Oxide.....	0.62%

NOTE: All RFS<sup>III</sup> sand filters shall have 24" of approved sand filtrate media. Bottom zone stone specifications: 16" of 1 ½" size stone, 8" of 3/8" to ½" size stone.

### DISINFECTION SPECIFICATIONS

Ultraviolet disinfection shall be utilized. Manufacturers vary according to application.



HYDRAULIC CALCULATIONS FOR RFS<sup>III</sup>  
DISTRIBUTION SYSTEM

*\*Hydraulic Calculations are based on 1 RFS<sup>III</sup> system. This plant will consist of 2 RFS<sup>III</sup> systems.*

Design Flow @.....	600GPD
Spray Grid Orifice Size.....	25" Diameter
Number of Laterals per Spray Grid.....	2
Spacing of Orifices @.....	52" On Center
Length of Laterals.....	10'
Total # of orifices per spray grid.....	4
Total # of orifices.....	8
Design Flow per orifice @.....	4.1 GPM
Total Design Flow per pump.....	33 GPM
Friction Loss through Recirculating Plumbing.....	51' (manifold)+ 1.41' (valve assembly)+ 1.52' (spray grid)
Friction loss through pump discharge.....	1.71'
Static Head.....	5.0'
Design Pressure Head per orifice.....	11.54'
Total Design for pump (min.).....	33.0 GPM @ 21.66 TDH
Proposed Pump.....	Zoeller 4161
Pump Characteristics (actual design).....	53.89 GPM @ 35.43'
Number of Pumps Proposed.....	1
Design recirculation ratio @.....	12:1
Number of cycles per day.....	72 (20min. cycles)

Compute on Time..... 600 GPD (12:1 Recirc. Ratio)  
53.89 GPM (72 Cycles/ Day) = 1.86 Min. on

Compute pump off time..... 20 Min. - 1.86 Min. on = 18.14 Min. off

20 Min. per cycle = (1.86 Min. on + 18.14 Min. off)

Required recycled flow for 12:1 ratio..... 7200 GPD

Total recycled flow @ 72 cycles x 1.86 min. on x 53.89 GPM = 7217 GPD

HYDRAULIC CALCULATIONS FOR RECIRCULATING TANK

Infiltrator chamber capacity = 133 gallons

50% of the capacity from the gravel storage zone = 566 gallons

Total recirculation tank capacity = 699 gallons

## 1. WARRANTY

Materials and associated components installed and supplied with the system are guaranteed from failure due to defect or workmanship for a period no less than two years after substantial completion. Replace any failed or defective component of the system at no expense to the Owner. Not included in this warranty are items normally consumed in the system's standard operation.

## 2. PERFORMANCE WARRANTY

1. RFS III re-circulating filter shall be designed to meet the following effluent criteria based on the following influent characteristic ranges
2. Influent Characteristics
 

a. Design Average Daily Wastewater Flow		600 gpd
b. 5-Day CBOD		50 to 200 mg/l
c. Suspended Solids Range		50 to 100 mg/l
d. pH Range		6.0 to 9.0
3. Effluent Criteria:
 

a. 5-Day CBOD	Avg Monthly	5 mg/l
b. Suspended Solids	Avg monthly	30 mg/l
c. NH <sub>3</sub> N		3 mg/l
d. D.O.		6 mg/l



**3885 Cast Iron Impeller  
Effluent Pumps  
MODEL : WE0712H**

**Submittal Data**

Hydraulic Data					Motor Data	WE Series 3885	Qty.
Maximum Flow	Flow at Duty Point	Maximum TDH	TDH at Duty Point	NPSH <sub>R</sub>	Voltage / Phase / Enclosure	Model	
94 US g.p.m.	54 US g.p.m.	66 ft	37 ft		230V 1 Phase	WE0712H	1

Submittal Prepared for: \_\_\_\_\_ Job: ASHCO RFS III  
 Engineer: \_\_\_\_\_ Contractor: \_\_\_\_\_  
 Submittal Prepared by: PRA \_\_\_\_\_ Company: \_\_\_\_\_  
 Submittal Date: 2010-06-21 \_\_\_\_\_ Approved by: \_\_\_\_\_ Date: \_\_\_\_\_

**Engineering Data**

Pump Code: WE0712H  
 Pump Size: 2" NPT Discharge  
 Pump Max Horsepower: 0 hp  
 Pump Horsepower at Rating Point: 0.00 hp  
 Pump Shut Off Head: 66 ft  
 Motor Speed: 3500 rpm  
 Max. Temperature: 104 °F  
 Liquid: Water, pure  
 Motor Code: WE0712  
 System Input Power: 1~ 230 V  
 Motor Rated Horsepower: 0.75 hp  
 Max. Frequency: 60  
 Discharge Flange Standard:  
 Discharge Flange Rating:  
 Discharge:  
 Approximate Net Weight: 70 lb  
 Impeller Size: 4 1/16"  
 Impeller Construction: Semi-open  
 Impeller Type: Radial impeller  
 Impeller Material:  
 Cast Iron  
 Sense of Rotation: Clockwise from the drive end

**Standard Equipment / Capability:**

**APPLICATIONS**  
 Specifically designed for the following uses:  
 • Homes • Farms • Trailer courts • Motels • Schools • Hospitals • Industry • Effluent systems

**SPECIFICATIONS**  
**Pump**  
 • Solids handling capabilities: 3/4" maximum. • Discharge size: 2" NPT.  
 • Capacities: up to 140 GPM. • Total heads: up to 128 feet TDH.  
 • Temperature:  
 104°F (40°C) continuous  
 140°F (60°C) intermittent.

**FEATURES**  
 Impeller: Cast iron, semiopen, non-clog with pumpout vanes for mechanical seal protection. Balanced for smooth operation. Silicon bronze impeller available as an option.  
 Casing: Cast iron volute type for maximum efficiency. 2" NPT discharge.  
 Mechanical Seal: SILICON CARBIDE VS. SILICON CARBIDE sealing faces.  
 Stainless steel metal parts, BUNA-N elastomers.  
 Shaft: Corrosion-resistant, stainless steel. Threaded design. Locknut on all models to guard against component damage on accidental reverse rotation.  
 Fasteners: 300 series stainless steel.  
 Capable of running dry without damage to components.  
 Designed for continuous operation when fully submerged.

**MOTORS**  
 Fully submerged in high-grade turbine oil for lubrication and efficient heat transfer.  
 Class B insulation on 1/3-1 1/2 HP models.  
 Class F insulation on 2 HP models.  
 Single phase (60 Hz):  
 • Capacitor start motors for maximum starting torque.  
 • Built-in overload with automatic reset.  
 • SJTOW or STOW severe duty oil and water resistant power cords.  
 • 1/3 – 1 HP models have NEMA three prong grounding plugs.  
 • 1 1/2 HP and larger units have bare lead cord ends.  
 Three phase (60 Hz):  
 • Class 10 overload protection must be provided in separately ordered starter unit.  
 • STOW power cords all have bare lead cord ends.  
 Designed for Continuous Operation; Pump ratings are within the motor manufacturer's recommended working limits, can be operated continuously without damage when fully submerged.  
 Bearings: Upper and lower heavy duty ball bearing construction.  
 Power Cable: Severe duty rated, oil and water resistant. Epoxy seal on motor end provides secondary moisture barrier in case of outer jacket damage and to prevent oil wicking. Standard cord is 20'. Optional lengths are available.  
 O-ring: Assures positive sealing against contaminants and oil leakage.



**3885 Cast Iron Impeller  
Effluent Pumps**

**Performance Data**

**MODEL : WE0712H**

Hydraulic Data					Motor Data	WE Series 3885	Qty.
Maximum Flow	Flow at Duty Point	Maximum TDH	TDH at Duty Point	NPSH <sub>R</sub>	Voltage / Phase / Enclosure	Model	
94 US g.p.m.	54 US g.p.m.	66 ft	37 ft		230V 1 Phase	WE0712H	1

Submittal Prepared for: \_\_\_\_\_ Job: ASHCO RFS III  
 Engineer: \_\_\_\_\_ Contractor: \_\_\_\_\_  
 Submittal Prepared by: PRA \_\_\_\_\_ Company: \_\_\_\_\_  
 Submittal Date: 2010-06-21 \_\_\_\_\_ Approved by: \_\_\_\_\_ Date: \_\_\_\_\_

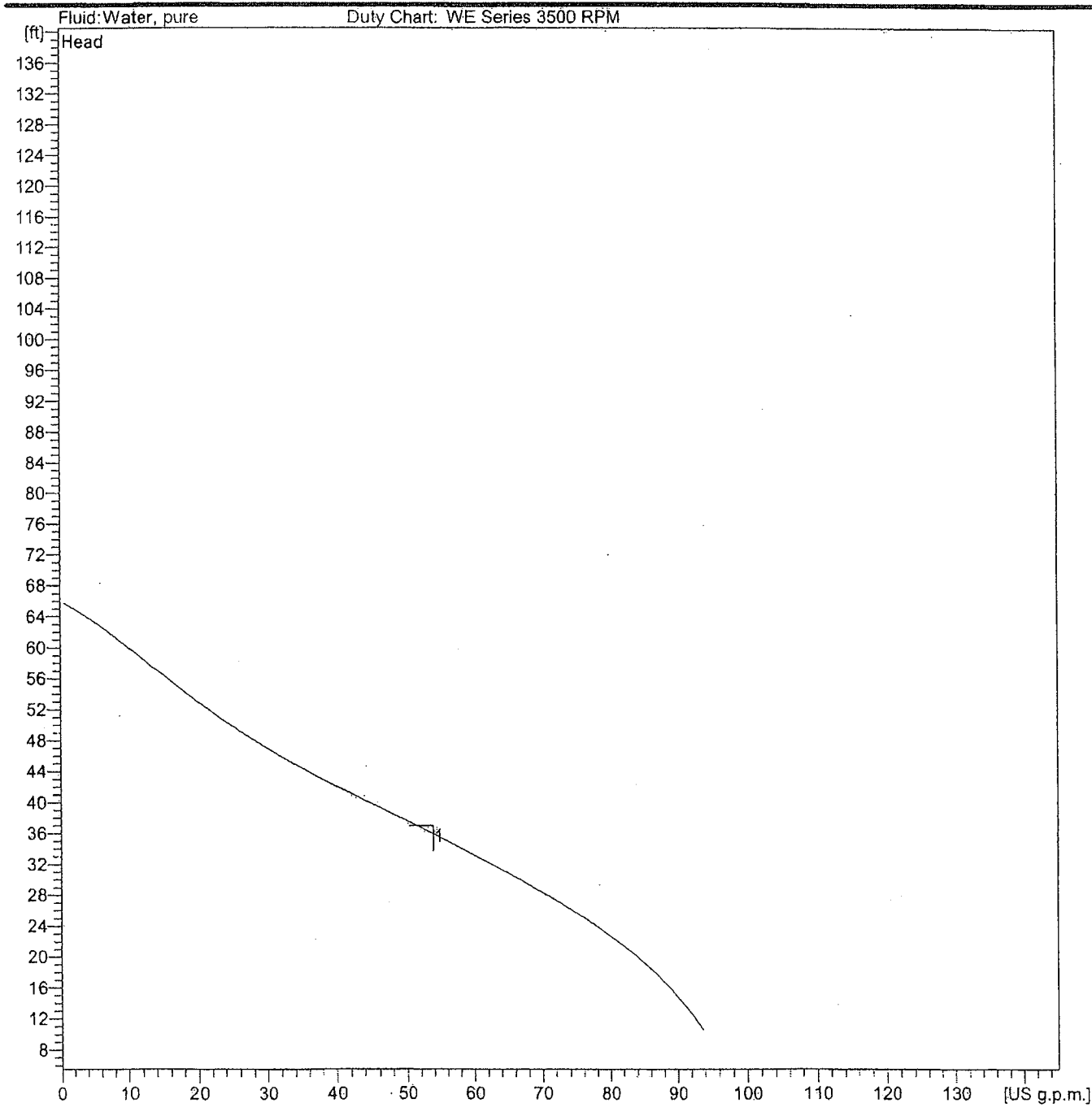

**GOULDS PUMPS**  
**Unit Dimensions**

**3885 Cast Iron Impeller  
 Effluent Pumps  
 MODEL : WE0712H**

Hydraulic Data				Motor Data		WE Series 3885	Qty.
Maximum Flow	Flow at Duty Point	Maximum TDH	TDH at Duty Point	NPSH <sub>r</sub>	Voltage / Phase / Enclosure	Model	
94 US g.p.m.	54 US g.p.m.	66 ft	37 ft.		230V 1 Phase	WE0712H	1

Submittal Prepared for: \_\_\_\_\_ Job: **ASHCO RFS III**  
 Engineer: \_\_\_\_\_ Contractor: \_\_\_\_\_  
 Submittal Prepared by: **PRA** Company: \_\_\_\_\_  
 Submittal Date: **2010-06-21** Approved by: \_\_\_\_\_ Date: \_\_\_\_\_

**(All dimensions are in inches. Do not use for construction purposes.)**

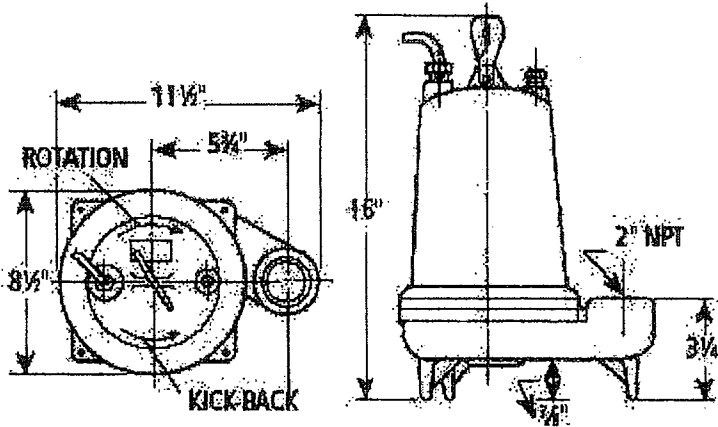

Dimension	Value	Dimension	Value
Discharge Size	2		
Max Solids	3/4		

# MVP-Simplex Control Panel

## Applications

The MVP-Simplex control panel is ideal for timed and on-demand dosing in single-pump systems. All MVPs include an easy-to-use, programmable logic unit that incorporates many timing and logic functions, such as multiple timing intervals to adjust for changing flow conditions and a built-in elapsed time meter and counter. Any water or wastewater system that requires a timer would benefit from the MVP's accuracy and versatility.

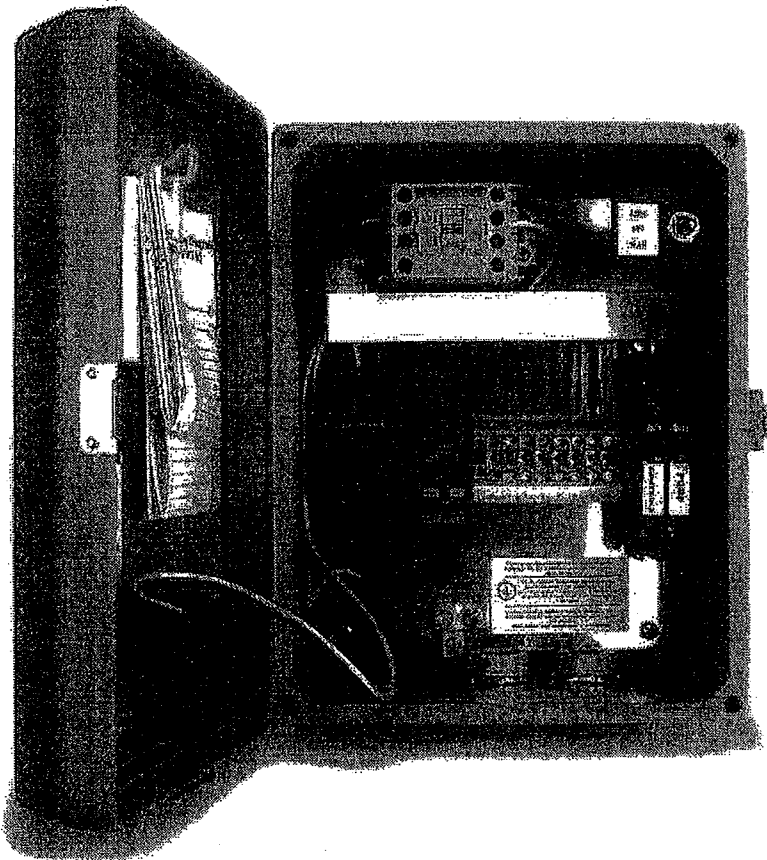

*Easy to set, accurate, and surprisingly affordable, the MVP brings intelligent control technology to the water and wastewater handling industries.*

## To Order

Call your nearest Orenco Systems® , Inc. distributor. For nearest distributor, call Orenco at 800-348-9843, or go to [www.orenco.com](http://www.orenco.com) and click on "Distributor Locator."



**Orenco Systems®**  
Incorporated

*Changing the Way the  
World Does Wastewater®*

800-348-9843  
[www.orenco.com](http://www.orenco.com)

## Standard Features & Benefits

- Eight inputs and four outputs
- Intervals as long as 99 hours can be set with an accuracy of  $\pm 1\%$
- Simple setting instructions are easy to remember
- Built-in programming keys allow reprogramming in the field without a portable computer
- Parameters have understandable abbreviations
- Multiple timer intervals (e.g., normal timer, override timer) can be set to accommodate varying flow conditions
- High-level alarm delay is adjustable
- When an alarm condition is reached, a minimum number of override cycles can be set to allow tank levels to drop, thus eliminating nuisance alarms
- Large, backlit LCD display is easy to read
- Ability to use one model of float for all functions simplifies installation
- UL 508 listed in the United States and Canada
- Complete instructions and diagrams come with panel and are affixed to the inside, for reference in the field
- Three-year limited warranty

## Standard Features for System Maintenance

- Visual cues (indicators of float position and different alarm/light signals for varying alarm conditions) aid system maintenance
- Built-in counters for low-level alarms, high-level alarms, overrides (on panels with timer), and power failures. Records total hours in service. These features provide valuable information for system maintenance and troubleshooting
- Timed delays on float inputs prevent chattering and pump burnout
- Automatic reactivation of silenced alarm (when problem is not corrected) helps prevent system failure

*(Optional features on back)*

### Optional Features & Benefits

- Removable EEPROM card for reprogramming the panel in the shop or in the field
- UL698A (Intrinsically Safe listing) for use in hazardous locations
- Self-regulating anticondensation heater (radiates additional wattage as temperature drops)
- Current sensor to signal pump failures; ideal for recirculating filters
- Pump run light to indicate pumping activity

### Standard Models

MVP-S1 PTR0, MVP-S2 PTR0  
 MVP-S1 RO, MVP-S2 RO

### Model Code for Ordering

**MVP - S**

Options (should appear in the following order):

- IR = intrinsically safe relay
- PT = programmable timer
- RO = redundant off
- CS = current sensor
- DS = disconnect switch
- RA = remote alarm (dry contact)
- TS = test switch
- HT = heater
- PRL = pump run light
- PL = power light
- SA = surge arrestor

Pump voltage:\*  
 1 = 115 VAC  
 2 = 230 VAC

Simplex series

MVP control panel

\* All panels require 115 VAC for the controls

1. Programmable Logic Unit
2. Motor-Start Contactor
3. Toggle Switch
4. Controls Circuit Breaker
5. Pump Circuit Breaker
6. Audible Alarm
7. Visual Alarm
8. Panel Enclosure

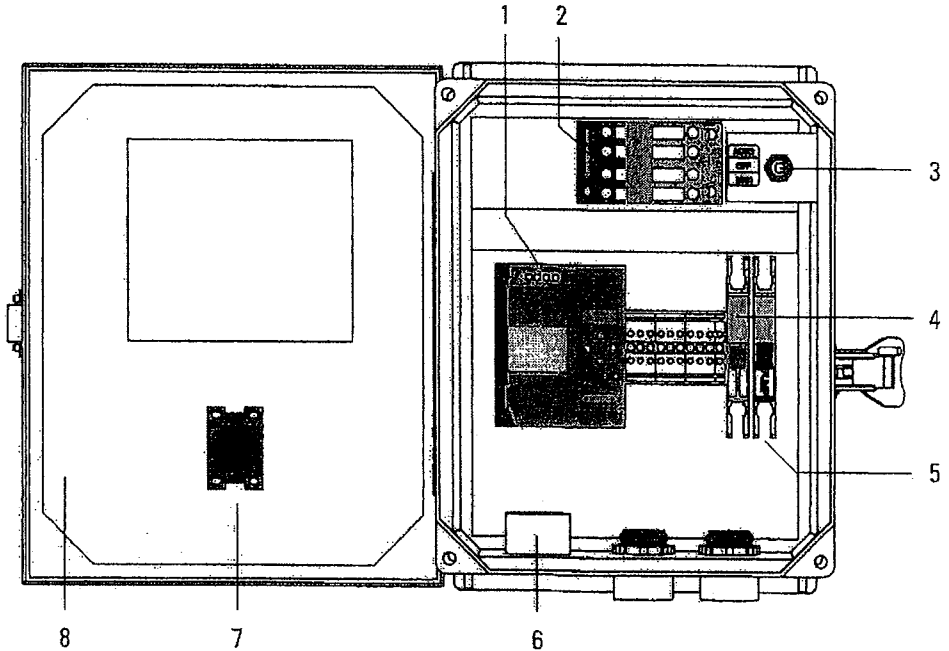

Distributed By:



# BLACK BEAUTY® COAL SLAG ABRASIVE SPECIFICATION SHEET

## GALLIPOLIS (04)

State Rt. No. 7  
 Cheshire, OH 45620  
 PHONE (740) 367-7322  
 FAX (740) 367-0408

<b>UTILITY</b> 1040	Coarse grade <b>BLACK BEAUTY</b> ® coal slag abrasive for tough blasting jobs, when a rough profile is needed, or for special applications; use for <b>HEAVY RUST, THICK &amp; TOUGH COATINGS, MASTICS, TANK LININGS, SHIPS &amp; BARGES, CONCRETE.</b>
<b>MEDIUM</b> 1240	Medium grade <b>BLACK BEAUTY</b> ® coal slag abrasive for general purpose repair or maintenance blasting; use for <b>REMOVAL OF PAINT &amp; RUST, STRUCTURAL STEEL, MILL SCALE, GENERAL PURPOSE, AGGREGATE EXPOSURE.</b>
<b>FINE</b> 2040	Fine grade <b>BLACK BEAUTY</b> ® coal slag abrasive for new construction, light paint and rust removal, or special maintenance applications requiring reduced profiles; use for <b>BRIDGE MAINTENANCE, LIGHT MILL SCALE, LIGHT PAINT &amp; RUST, NEW STRUCTURAL STEEL.</b>
<b>EX-FINE</b> 2040	Extra-fine grade <b>BLACK BEAUTY</b> ® coal slag abrasive to clean surfaces and create a smooth finish, <b>Brush-Off Blast</b> , or in a high pressure water blast system.

TYLER/U.S.	UTILITY	MEDIUM	FINE	EX-FINE
No. 1	- 0 -			
No. 2	0 - 2			
No. 3	0 - 15			
No. 4	45 - 75		- 0 -	
No. 5	10 - 35		0 - 2	
No. 6	0 - 10	20 - 35	0 - 15	10 - 20
No. 7		10 - 25	30 - 50	10 - 5
No. 8		20 - 40	20 - 45	
No. 9			0 - 15	
No. 10				75 - 100
No. 100/100				4 - 10
PAN	0 - 5	0 - 5	0 - 10	0 - 5





Addendum #3 #VET10112 (General Construction & Site Work)

Bid Form

Donel Kinnard Memorial State Veterans Cemetery  
Charleston, West Virginia

Bid Proposal of Kanawha Stone Company, Inc.  
(hereafter called "Bidder") organized and existing under the laws of the State of West Virginia  
and doing business as \_\_\_\_\_

**\*A Corporation**

(\*Insert "A Corporation", "A Partnership", or "An Individual")

To the West Virginia Division of Veterans Affairs (hereafter called "Owner"):

The Bidder, in compliance with your Invitation to Bid and the Request for Quotation issued by Purchasing Division of the West Virginia Department of Administration soliciting bonafide bids for the Donel Kinnard Memorial State Veterans Cemetery, Charleston, West Virginia, having examined the Bidding Documents and the site of the proposed work, and being familiar with all of the conditions surrounding the construction of the Project including the availability of materials and labor, hereby proposes to provide all labor, materials, tools and equipment necessary to complete the construction of the Project in accordance with the Bidding Documents (of which this Bid Form is a part), within the time set forth herein, and at the prices stated below.

The Bidder acknowledges receipt of the following Addenda:

1	2	3
<i>VRK</i>	<i>VRK</i>	<i>VRK</i>

**GENERAL CONSTRUCTION AND SITE WORK:**

The Contractor hereby agrees to commence work on the Project on or before a date to be specified in a written "Notice to Proceed" of the Owner. The Contractor agrees to fully complete the Project in 390 calendar days. The Contractor also agrees, for each calendar day of delay in completion of the Project beyond the stated length construction period to be liable for and pay to the Owner liquidated damages in the amount of \$750.00 per day, subject to allowances for delays beyond the control of the Contractor, all reasons for delays properly documented and verified.

**General Construction and Sitework - Base Bid Proposal:** The Bidder agrees to complete all Base Bid Proposal work on the Project, as required by the Bidding Documents for the following Sum:

*ELEVEN MILLION, SIX HUNDRED FIFTY SEVEN THOUSAND, ONE HUNDRED FIFTY FOUR DOLLARS & ZERO CENTS* (\$ *11,657,154<sup>00</sup>*)  
(Show amount in both words and figures)

In the event of a discrepancy between the wording of the Base Bid amount and the figure of the Base Bid amount, the wording shall govern.

**Addendum #3 #VET10112 (General Construction & Site Work)**

**General Construction and Sitework - Alternate Proposals:** The Bidder agrees to perform the individual Alternate work as required by the Bidding Documents for the following Sum(s):

Alternate No. 1: Add 834 pre-placed crypts as indicated on sheet C900. This alternate includes all labor and materials for earthwork, drainage stone, underdrains, cleanouts, precast concrete crypts, backfill, irrigation, gravesite grid monuments and burial section markers. Landscaping and seeding is base bid.

Six Hundred Sixty Seven Thousand Two Hundred Dollars & Zero Cents ADD(\$ 667,200<sup>00</sup> )  
(Show amount in both words and figures)

Alternate No. 2: Provide 4) Electric Heaters with T-stats, including all associated wiring and raceways to electric panel, in the Maintenance Building as indicated on Drawings M101M and E102M.

Twenty Four Thousand, Four Hundred Dollars & Zero Cents ADD(\$ 24,400<sup>00</sup> )  
(Show amount in both words and figures)

In the event of a discrepancy between the wording of the Alternate amount(s) and the figure of the Alternate amounts(s), the wording shall govern.

**General Construction and Sitework - Unit Prices:**

The Unit Prices shall determine the value of extra Work or changes in the Work, as applicable. They shall be considered complete and shall include all material and equipment, labor, installation costs, overhead, and profit. Unit prices shall be used uniformly for additions or deductions.

Unit Price No. 1 – Clearing and Grubbing: Clear and grub additional land as required to spoil additional earth.

\$ 5000<sup>00</sup> / Acre

Unit Price No. 2 – Stripping and Stockpiling Topsoil: Strip and stockpile additional topsoil from land as required to spoil additional earth.

\$ 14<sup>00</sup> / Cubic Yard

Unit Price No. 3 – Granular Fill: Provide specified gravel sub-base material, placed and compacted.

\$ 50<sup>00</sup> / Cubic Yard

FAILURE TO PROVIDE COMPLETELY FILLED-IN DATA FOR ALL OF THE ALTERNATES AND UNIT PRICES INDICATED ABOVE WILL RESULT IN THE BID BEING CONSIDERED NON-RESPONSIVE.

**Addendum #3 #VET10112A (Landscaping)**

The Bidder understands that, depending upon the availability of funds, the Owner may, at its own discretion, accept Alternates. The Bidder further understands that it is the intent of the Owner to award a contract on the basis of lowest Base Proposal amount with or without modification by any or all of the Alternate Proposal amounts, as may solely benefit the Owner.

**LANDSCAPING:**

The Contractor hereby agrees to commence work on the Project on or before a date to be specified in a written "Notice to Proceed" of the Owner. The Contractor agrees to fully complete the Project in 90 calendar days. The Contractor also agrees, for each calendar day of delay in completion of the Project beyond the stated length construction period to be liable for and pay to the Owner liquidated damages in the amount of \$750.00 per day, subject to allowances for delays beyond the control of the Contractor, all reasons for delays properly documented and verified.

**Landscaping - Base Bid Proposal:** The Bidder agrees to complete all Base Bid Proposal work on the Project, as required by the Bidding Documents for the following Sum:

FOUR HUNDRED SIXTY ONE THOUSAND FOUR  
HUNDRED FIFTY DOLLARS & ZERO CENTS (\$ 461,450<sup>00</sup>)  
(Show amount in both words and figures)

In the event of a discrepancy between the wording of the Base Bid amount and the figure of the Base Bid amount, the wording shall govern.

**Landscaping - Alternate Proposals:** The Bidder agrees to perform the individual Alternate work as required by the Bidding Documents for the following Sum(s):

Alternate No. L1: Provide sod as specified in LIMITED AREAS (in lieu of seed) as indicated on Planting Plan Sheets L100, L102 and L104.

FIFTY ONE THOUSAND, FIVE HUNDRED SEVENTY  
DOLLARS & ZERO CENTS ADD(\$ 51,570<sup>00</sup>)  
(Show amount in both words and figures)

Alternate No. L2: Provide sod as specified in ALL REMAINING AREAS indicated as "LAWN: GRASS MIX" on Planting Plan Sheets (L100 series). This alternate assumes that Alternate No. L1 is already accepted.

THREE HUNDRED THIRTY EIGHT THOUSAND ONE  
HUNDRED DOLLARS & ZERO CENTS ADD(\$ 338,100<sup>00</sup>)  
(Show amount in both words and figures)

In the event of a discrepancy between the wording of the Alternate amount(s) and the figure of the Alternate amounts(s), the wording shall govern.

**Addendum #3 #VET10112A (Landscaping)****Landscaping - Unit Prices:**

The Unit Prices shall determine the value of extra Work or changes in the Work, as applicable. They shall be considered complete and shall include all material and equipment, labor, installation costs, overhead, and profit. Unit prices shall be used uniformly for additions or deductions.

Unit Price No. L1 – Sod: Provide sod installed and maintained as specified.

\$ 834<sup>00</sup> / 1,000 SF

FAILURE TO PROVIDE COMPLETELY FILLED-IN DATA FOR ALL OF THE ALTERNATES AND UNIT PRICES INDICATED ABOVE WILL RESULT IN THE BID BEING CONSIDERED NON-RESPONSIVE.

The Bidder understands that, depending upon the availability of funds, the Owner may, at its own discretion, accept Alternates. The Bidder further understands that it is the intent of the Owner to award a contract on the basis of lowest Base Proposal amount with or without modification by any or all of the Alternate Proposal amounts, as may solely benefit the Owner:

---

The Owner agrees to authorize disbursement to the Contractor for the performance of the Contract, and to make payment on 90% of the contract sum properly allocable to labor and materials completed on the Work up to the first (1<sup>st</sup>) day of each month, less the aggregate of previous payments in each case. At the time the Work is fifty percent (50%) complete and thereafter, if the manner of completion of the Work and its progress are and remain satisfactory to the Owner and Architect, upon presentation by the Contractor of Consent of Surety, the Architect will authorize any remaining partial payments to be paid in full. Upon Substantial Completion of the Work, the payment of retainage shall be sufficient to increase the total payments to ninety-five percent (95%) for the Work designated as Substantially Complete, less any amounts as the Architect shall determine for any Work that is not complete.

The Bidder has enclosed a Bid Bond for not less than 5% of the bid proposal price indicated above.

Upon receipt of written Notice of the acceptance of this bid, the Bidder agrees to promptly furnish, within 10 calendar days of Notice, satisfactory Performance and Labor and Material Payment Bonds in the amount of the Contract Price.

---

Respectfully submitted for:

**Kanawha Stone Company, Inc.**

(Firm Name)

Contractor's WV License Number: WV006094

(Pursuant to the WV Contractor Licensing Act 1991, 21-11-11)

Addendum #3 #VET10112A (Landscaping)

By: Virginia L. King Vice President  
Virginia L. King (Signature & Title)

WV Business Registration Number: 1035-8859

Business Address: P O Box 503, Nitro WV 25143

SEAL (if Bid is by a Corporation)

# CONTRACTOR LICENSE

Authorized by the

**West Virginia Contractor Licensing Board**

**Number:**

WV006094

**Classification:**

GENERAL BUILDING  
GENERAL ENGINEERING

KANAWHA STONE COMPANY INC  
DBA KANAWHA STONE COMPANY INC  
PO BOX 503  
NITRO, WV 25143-0503

**Date Issued**

**Expiration Date**

SEPTEMBER 24, 2009

SEPTEMBER 24, 2010

  
Authorized Company Signature

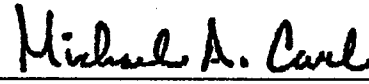
  
Chair, West Virginia Contractor  
Licensing Board

This license, or a copy thereof, must be posted in a conspicuous place at every construction site where work is being performed. This license number must appear in all advertisements, on all bid submissions and on all fully executed and binding contracts. This license cannot be assigned or transferred by licensee. Issued under provisions of West Virginia Code, Chapter 21, Article 11.



**WEST VIRGINIA  
CONTRACTOR  
LICENSING  
BOARD**

**BID BOND**

KNOW ALL MEN BY THESE PRESENTS, That we, the undersigned, \_\_\_\_\_  
of \_\_\_\_\_, \_\_\_\_\_, as Principal, and \_\_\_\_\_  
of \_\_\_\_\_, \_\_\_\_\_, a corporation organized and existing under the laws of the State of \_\_\_\_\_  
with its principal office in the City of \_\_\_\_\_, as Surety, are held and firmly bound unto the State  
of West Virginia, as Obligee, in the penal sum of \_\_\_\_\_ (\$ \_\_\_\_\_) for the payment of which,  
well and truly to be made, we jointly and severally bind ourselves, our heirs, administrators, executors, successors and assigns.

The Condition of the above obligation is such that whereas the Principal has submitted to the Purchasing Section of the  
Department of Administration a certain bid or proposal, attached hereto and made a part hereof, to enter into a contract in writing for  
\_\_\_\_\_  
\_\_\_\_\_  
\_\_\_\_\_

**NOW THEREFORE,**

- (a) If said bid shall be rejected, or
- (b) If said bid shall be accepted and the Principal shall enter into a contract in accordance with the bid or proposal attached hereto and shall furnish any other bonds and insurance required by the bid or proposal, and shall in all other respects perform the agreement created by the acceptance of said bid, then this obligation shall be null and void, otherwise this obligation shall remain in full force and effect. It is expressly understood and agreed that the liability of the Surety for any and all claims hereunder shall, in no event, exceed the penal amount of this obligation as herein stated.

The Surety, for the value received, hereby stipulates and agrees that the obligations of said Surety and its bond shall be in no way impaired or affected by any extension of the time within which the Obligee may accept such bid, and said Surety does hereby waive notice of any such extension.

IN WITNESS WHEREOF, Principal and Surety have hereunto set their hands and seals, and such of them as are corporations have caused their corporate seals to be affixed hereunto and these presents to be signed by their proper officers, this \_\_\_\_\_ day of \_\_\_\_\_, 20\_\_\_\_.

Principal Corporate Seal

\_\_\_\_\_  
(Name of Principal)

By \_\_\_\_\_  
(Must be President or Vice President)

\_\_\_\_\_  
(Title)

Surety Corporate Seal

\_\_\_\_\_  
(Name of Surety)

\_\_\_\_\_  
Attorney-in-Fact

**IMPORTANT – Surety executing bonds must be licensed in West Virginia to transact surety insurance. Raised corporate seals must be affixed, a power of attorney must be attached.**

AGENCY (A)
RFQ/RFP# (B)

Bid Bond

- (A) WV State Agency (Stated on Page 1 "Spending Unit") Request for Quotation Number (upper right corner of page #1)
(C) Your Company Name
(D) City, Location of your Company
(E) State, Location of your Company
(F) Surety Corporate Name
(G) City, Location of Surety
(H) State, Location of Surety
(I) State of Surety Incorporation
(J) City of Surety Incorporation
(K) Minimum amount of acceptable bid bond is 5% of total bid. You may state "5% of bid" or a specific amount on this line in words.
(L) Amount of bond in figures
(M) Brief Description of scope of work
(N) Day of the month
(O) Month
(P) Year
(Q) Name of Corporation
(R) Raised Corporate Seal of Principal
(S) Signature of President or Vice President
(T) Title of person signing
(U) Raised Corporate Seal of Surety
(V) Corporate Name of Surety
(W) Signature of Attorney in Fact of the Surety

KNOW ALL MEN BY THESE PRESENTS, That we, the undersigned, (C) of (D), (E), as Principal, and (F) of (G), (H), a corporation organized and existing under the laws of the State of (I) with its principal office in the City of (J), as Surety, are held and firmly bound unto The State of West Virginia, as Obligee, in the penal sum of (K) (\$ (L)) for the payment of which, well and truly to be made, we jointly and severally bind ourselves, our heirs, administrators, executors, successors and assigns.

The Condition of the above obligation is such that whereas the Principal has submitted to the Purchasing Section of the Department of Administration a certain bid or proposal, attached hereto and made a part hereof to enter into a contract in writing for (M)

NOW THEREFORE.

(a) If said bid shall be rejected, or
(b) If said bid shall be accepted and the Principal shall enter into a contract in accordance with the bid or proposal attached hereto and shall furnish any other bonds and insurance required by the bid or proposal, and shall in all other respects perform the agreement created by the acceptance of said bid then this obligation shall be null and void, otherwise this obligation shall remain in full force and effect. It is expressly understood and agreed that the liability of the Surety for any and all claims hereunder shall, in no event, exceed the penal amount of this obligation as herein stated

The Surety for value received, hereby stipulates and agrees that the obligations of said Surety and its bond shall be in no way impaired or affected by any extension of time within which the Obligee may accept such bid: and said Surety does hereby waive notice of any such extension.

IN WITNESS WHEREOF, Principal and Surety have hereunto set their hands and seals, and such of them as are corporations have caused their corporate seals to be affixed hereto and these presents to be signed by their proper officers, this (N) day of (O), 20 (P).

Principal Corporate Seal

(R)

(U) Surety Corporate Seal

(Q) (Name of Principal)
By (S) (Must be President or Vice President)
(T) Title
(V) (Name of Surety)
(W) Attorney-in-Fact

IMPORTANT - Surety executing bonds must be licensed in West Virginia to transact surety insurance. Raised Corporate Seals must be affixed and a Power of Attorney must be attached.



BID BOND

KNOW ALL MEN BY THESE PRESENTS, That we, the undersigned, Kanawha Stone Company, Inc.  
of Nitro, WV, as Principal, and Travelers Casualty and Surety Company of America  
of Hartford, CT, a corporation organized and existing under the laws of the State of  
CT with its principal office in the City of Hartford, as Surety, are held and firmly bound unto the State  
of West Virginia, as Obligee, in the penal sum of Five Percent of Amount Bid (\$ 5%) for the payment of which,  
well and truly to be made, we jointly and severally bind ourselves, our heirs, administrators, executors, successors and assigns.

The Condition of the above obligation is such that whereas the Principal has submitted to the Purchasing Section of the  
Department of Administration a certain bid or proposal, attached hereto and made a part hereof, to enter into a contract in writing for  
Donel Kinnard Memorial State Veterans Cemetery

NOW THEREFORE,

- (a) If said bid shall be rejected, or
- (b) If said bid shall be accepted and the Principal shall enter into a contract in accordance with the bid or proposal attached  
hereto and shall furnish any other bonds and insurance required by the bid or proposal, and shall in all other respects perform the  
agreement created by the acceptance of said bid, then this obligation shall be null and void, otherwise this obligation shall remain in full  
force and effect. It is expressly understood and agreed that the liability of the Surety for any and all claims hereunder shall, in no event,  
exceed the penal amount of this obligation as herein stated.

The Surety, for the value received, hereby stipulates and agrees that the obligations of said Surety and its bond shall be in no  
way impaired or affected by any extension of the time within which the Obligee may accept such bid, and said Surety does hereby  
waive notice of any such extension.

IN WITNESS WHEREOF, Principal and Surety have hereunto set their hands and seals, and such of them as are corporations  
have caused their corporate seals to be affixed hereunto and these presents to be signed by their proper officers, this  
13th day of July, 2010

Principal Corporate Seal

Kanawha Stone Company, Inc.  
(Name of Principal)  
By Virginia R. Hine  
(Must be President or  
Vice President)  
Vice President  
(Title)

Surety Corporate Seal

Travelers Casualty and Surety Company of America  
(Name of Surety)  
By: D.P. Taylor  
Douglas P. Taylor, Licensed WV Resident Agent Attorney-in-Fact

IMPORTANT – Surety executing bonds must be licensed in West Virginia to transact surety insurance. Corporate seals must be affixed,  
and a power of attorney must be attached.



POWER OF ATTORNEY

Farmington Casualty Company
Fidelity and Guaranty Insurance Company
Fidelity and Guaranty Insurance Underwriters, Inc.
Seaboard Surety Company
St. Paul Fire and Marine Insurance Company

St. Paul Guardian Insurance Company
St. Paul Mercury Insurance Company
Travelers Casualty and Surety Company
Travelers Casualty and Surety Company of America
United States Fidelity and Guaranty Company

Attorney-In Fact No. 220306

Certificate No. 002970827

KNOW ALL MEN BY THESE PRESENTS: That Seaboard Surety Company is a corporation duly organized under the laws of the State of New York, that St. Paul Fire and Marine Insurance Company, St. Paul Guardian Insurance Company and St. Paul Mercury Insurance Company are corporations duly organized under the laws of the State of Minnesota, that Farmington Casualty Company, Travelers Casualty and Surety Company, and Travelers Casualty and Surety Company of America are corporations duly organized under the laws of the State of Connecticut, that United States Fidelity and Guaranty Company is a corporation duly organized under the laws of the State of Maryland, that Fidelity and Guaranty Insurance Company is a corporation duly organized under the laws of the State of Iowa, and that Fidelity and Guaranty Insurance Underwriters, Inc. is a corporation duly organized under the laws of the State of Wisconsin (herein collectively called the "Companies"), and that the Companies do hereby make, constitute and appoint

Andrew K. Teeter, Donna J. Price, Douglas P. Taylor, Kimberly L. Miles, C. Lee Jordan, Pamela V. Lanham, and Christopher A. Michel

of the City of Charleston, State of West Virginia, their true and lawful Attorney(s)-in-Fact, each in their separate capacity if more than one is named above, to sign, execute, seal and acknowledge any and all bonds, recognizances, conditional undertakings and other writings obligatory in the nature thereof on behalf of the Companies in their business of guaranteeing the fidelity of persons, guaranteeing the performance of contracts and executing or guaranteeing bonds and undertakings required or permitted in any actions or proceedings allowed by law.

IN WITNESS WHEREOF, the Companies have caused this instrument to be signed and their corporate seals to be hereto affixed, this 28th day of April, 2009.

Farmington Casualty Company
Fidelity and Guaranty Insurance Company
Fidelity and Guaranty Insurance Underwriters, Inc.
Seaboard Surety Company
St. Paul Fire and Marine Insurance Company

St. Paul Guardian Insurance Company
St. Paul Mercury Insurance Company
Travelers Casualty and Surety Company
Travelers Casualty and Surety Company of America
United States Fidelity and Guaranty Company



State of Connecticut
City of Hartford ss.

By: [Signature]
George W. Thompson, Senior Vice President

On this the 28th day of April, 2009, before me personally appeared George W. Thompson, who acknowledged himself to be the Senior Vice President of Farmington Casualty Company, Fidelity and Guaranty Insurance Company, Fidelity and Guaranty Insurance Underwriters, Inc., Seaboard Surety Company, St. Paul Fire and Marine Insurance Company, St. Paul Guardian Insurance Company, St. Paul Mercury Insurance Company, Travelers Casualty and Surety Company, Travelers Casualty and Surety Company of America, and United States Fidelity and Guaranty Company, and that he, as such, being authorized so to do, executed the foregoing instrument for the purposes therein contained by signing on behalf of the corporations by himself as a duly authorized officer.

In Witness Whereof, I hereunto set my hand and official seal.
My Commission expires the 30th day of June, 2011.



[Signature]
Marie C. Tetreault, Notary Public

This Power of Attorney is granted under and by the authority of the following resolutions adopted by the Boards of Directors of Farmington Casualty Company, Fidelity and Guaranty Insurance Company, Fidelity and Guaranty Insurance Underwriters, Inc., Seaboard Surety Company, St. Paul Fire and Marine Insurance Company, St. Paul Guardian Insurance Company, St. Paul Mercury Insurance Company, Travelers Casualty and Surety Company, Travelers Casualty and Surety Company of America, and United States Fidelity and Guaranty Company, which resolutions are now in full force and effect, reading as follows:

**RESOLVED**, that the Chairman, the President, any Vice Chairman, any Executive Vice President, any Senior Vice President, any Vice President, any Second Vice President, the Treasurer, any Assistant Treasurer, the Corporate Secretary or any Assistant Secretary may appoint Attorneys-in-Fact and Agents to act for and on behalf of the Company and may give such appointee such authority as his or her certificate of authority may prescribe to sign with the Company's name and seal with the Company's seal bonds, recognizances, contracts of indemnity, and other writings obligatory in the nature of a bond, recognizance, or conditional undertaking, and any of said officers or the Board of Directors at any time may remove any such appointee and revoke the power given him or her; and it is

**FURTHER RESOLVED**, that the Chairman, the President, any Vice Chairman, any Executive Vice President, any Senior Vice President or any Vice President may delegate all or any part of the foregoing authority to one or more officers or employees of this Company, provided that each such delegation is in writing and a copy thereof is filed in the office of the Secretary; and it is

**FURTHER RESOLVED**, that any bond, recognizance, contract of indemnity, or writing obligatory in the nature of a bond, recognizance, or conditional undertaking shall be valid and binding upon the Company when (a) signed by the President, any Vice Chairman, any Executive Vice President, any Senior Vice President or any Vice President, any Second Vice President, the Treasurer, any Assistant Treasurer, the Corporate Secretary or any Assistant Secretary and duly attested and sealed with the Company's seal by a Secretary or Assistant Secretary; or (b) duly executed (under seal, if required) by one or more Attorneys-in-Fact and Agents pursuant to the power prescribed in his or her certificate or their certificates of authority or by one or more Company officers pursuant to a written delegation of authority; and it is

**FURTHER RESOLVED**, that the signature of each of the following officers: President, any Executive Vice President, any Senior Vice President, any Vice President, any Assistant Vice President, any Secretary, any Assistant Secretary, and the seal of the Company may be affixed by facsimile to any power of attorney or to any certificate relating thereto appointing Resident Vice Presidents, Resident Assistant Secretaries or Attorneys-in-Fact for purposes only of executing and attesting bonds and undertakings and other writings obligatory in the nature thereof, and any such power of attorney or certificate bearing such facsimile signature or facsimile seal shall be valid and binding upon the Company and any such power so executed and certified by such facsimile signature and facsimile seal shall be valid and binding on the Company in the future with respect to any bond or understanding to which it is attached.

I, Kori M. Johanson, the undersigned, Assistant Secretary, of Farmington Casualty Company, Fidelity and Guaranty Insurance Company, Fidelity and Guaranty Insurance Underwriters, Inc., Seaboard Surety Company, St. Paul Fire and Marine Insurance Company, St. Paul Guardian Insurance Company, St. Paul Mercury Insurance Company, Travelers Casualty and Surety Company, Travelers Casualty and Surety Company of America, and United States Fidelity and Guaranty Company do hereby certify that the above and foregoing is a true and correct copy of the Power of Attorney executed by said Companies, which is in full force and effect and has not been revoked.

IN TESTIMONY WHEREOF, I have hereunto set my hand and affixed the seals of said Companies this 13th day of July, 20 10.

WARNING: THIS POWER OF ATTORNEY IS INVALID WITHOUT THE RED BORDER

  
Kori M. Johanson, Assistant Secretary



To verify the authenticity of this Power of Attorney, call 1-800-421-3880 or contact us at [www.travelersbond.com](http://www.travelersbond.com). Please refer to the Attorney-In-Fact number, the above-named individuals and the details of the bond to which the power is attached.



State of West Virginia  
DRUG FREE WORKPLACE CONFORMANCE AFFIDAVIT  
West Virginia Code §21-1D-5

STATE OF West Virginia

COUNTY OF Putnam, TO-WIT:

I, Virginia L. King, after being first duly sworn, depose and state as follows:

- 1. I am an employee of Kanawha Stone Company, Inc.; and,  
(Company Name)
- 2. I do hereby attest that Kanawha Stone Company, Inc.  
(Company Name)

maintains a valid written drug free workplace policy and that such policy is in compliance with **West Virginia Code §21-1D-5**.

The above statements are sworn to under the penalty of perjury.

Kanawha Stone Company, Inc.  
(Company Name)

By: Virginia L. King

Title: Vice President

Date: 7/13/2010

Taken, subscribed and sworn to before me this 13 day of July 2010



Angela D. Lake  
(Notary Public)

**THIS AFFIDAVIT MUST BE SUBMITTED WITH THE BID IN ORDER TO COMPLY WITH WV CODE PROVISIONS. FAILURE TO INCLUDE THE AFFIDAVIT WITH THE BID SHALL RESULT IN DISQUALIFICATION OF THE BID.**

STATE OF WEST VIRGINIA  
Purchasing Division

# PURCHASING AFFIDAVIT

West Virginia Code §5A-3-10a states: No contract or renewal of any contract may be awarded by the state or any of its political subdivisions to any vendor or prospective vendor when the vendor or prospective vendor or a related party to the vendor or prospective vendor is a debtor and the debt owed is an amount greater than one thousand dollars in the aggregate.

**DEFINITIONS:**

"Debt" means any assessment, premium, penalty, fine, tax or other amount of money owed to the state or any of its political subdivisions because of a judgment, fine, permit violation, license assessment, defaulted workers' compensation premium, penalty or other assessment presently delinquent or due and required to be paid to the state or any of its political subdivisions, including any interest or additional penalties accrued thereon.

"Debtor" means any individual, corporation, partnership, association, limited liability company or any other form or business association owing a debt to the state or any of its political subdivisions. "Political subdivision" means any county commission; municipality; county board of education; any instrumentality established by a county or municipality; any separate corporation or instrumentality established by one or more counties or municipalities, as permitted by law; or any public body charged by law with the performance of a government function or whose jurisdiction is coextensive with one or more counties or municipalities. "Related party" means a party, whether an individual, corporation, partnership, association, limited liability company or any other form or business association or other entity whatsoever, related to any vendor by blood, marriage, ownership or contract through which the party has a relationship of ownership or other interest with the vendor so that the party will actually or by effect receive or control a portion of the benefit, profit or other consideration from performance of a vendor contract with the party receiving an amount that meets or exceeds five percent of the total contract amount.

**EXCEPTION:** The prohibition of this section does not apply where a vendor has contested any tax administered pursuant to chapter eleven of this code, workers' compensation premium, permit fee or environmental fee or assessment and the matter has not become final or where the vendor has entered into a payment plan or agreement and the vendor is not in default of any of the provisions of such plan or agreement.

Under penalty of law for false swearing (*West Virginia Code §61-5-3*), it is hereby certified that the vendor affirms and acknowledges the information in this affidavit and is in compliance with the requirements as stated.

**WITNESS THE FOLLOWING SIGNATURE**

Vendor's Name: Kanawha Stone Company, Inc.

Authorized Signature: Virginia L. King Date: July 13, 2010  
Virginia L. King, Vice President

State of West Virginia

County of Putnam, to-wit:

Taken, subscribed, and sworn to before me this 13 day of July, 2010.

My Commission expires 11-12-2014, 20  .

AFFIX SEAL HERE

NOTARY PUBLIC

Angela D. Lake

