

**verizon**business

**A PROPOSAL TO**

**STATE OF WEST VIRGINIA**

**Department of Administration – IS&C**

**For  
Uninterruptible Power Supply  
RFQ # ISCL0048  
(Alternate Response)**

**January 20, 2011**



**PRESENTED BY:**

**Sandra K. Hawkins  
Senior Client Account Manager  
304-356-3395  
304-807-0207 (cell)  
[sandra.k.hawkins@verizonbusiness.com](mailto:sandra.k.hawkins@verizonbusiness.com)**

RECEIVED

2011 JAN 20 AM 10:44

WV PURCHASING  
DIVISION

January 20, 2011

State of West Virginia  
Department of Administration  
Purchasing Division  
Building 15  
2019 Washington Street East  
Charleston, WV 25305-0130

Attn: Krista Ferrell

RE: RFQ ISCL0048

Dear Ms. Ferrell:

Verizon is pleased to submit its proposal to provide and install an American Power Conversion (APC) Uninterruptible Power Supply as an alternate, more cost-effective response to RFQ ISCL0048.

Verizon is one of the world's leading providers of communications services. Verizon companies are the largest providers of wireline and wireless communications in the United States, with more than 100 million access lines and more than 25 million wireless customers. A Fortune 10 company with more than 195,000 employees and approximately \$60 billion in 1999 revenue, Verizon's global presence extends to 40 countries in the Americas, Europe, Asia and the Pacific.

Verizon will provide outstanding service quality, product flexibility, and a local dedicated Account Team. Both customers and industry analysts continue to recognize Verizon for its service performance and customer care. Verizon has received several notable industry –analyst marks of distinction, including:

- Frost & Sullivan named Verizon a Top Provider of Global Managed Security Services in its 2010 "Global Managed Security Service Providers Rollup" report
- Nemertes Research named Verizon as the Top Provider among Market Leaders for multiprotocol label switching (MPLS) and Carrier Ethernet services, with two 2010 Nemertes PilotHouse Awards.
- Gartner Inc. placed Verizon in the Leaders quadrant in the "Magic Quadrant for Communications Outsourcing and Professional Services, North America.
- Verizon has earned certification as ISO/IEC 20000-1-compliant for its Government Enterprise Network Operations Center (GENOC), located in Cary, N.C. The GENOC, launched in 1997, provides managed services for local, state, and federal government customers.
- J.D.Power and Associates has consistently ranked Verizon highest in Customer Satisfaction since 2004 in the Telecommunications Industry Segment.

- Verizon is the first communications provider to earn the Better Business Torch Award in the area of Marketplace Excellence. (2010)
- Verizon has been named Global Service Provider of the Year, North America, by Polycom. (2010)
- Verizon has been named to the Global 100 of Newsweek magazine's annual green rankings.
- Verizon has received awards from Cisco for Service Provider Partner of the Year, Managed Service Provider Partner of the Year, Data Center Partner of the Year, Unified Communications & Collaboration Partner of the Year, Managed Service Partner of the Year and Technology Excellence Partner of the Year (2009).

Verizon commits to provide the services as described in this Proposal. I also give my personal commitment of service to the State of West Virginia. I look forward to continuing our business relationship and building an even stronger partnership with the State of West Virginia.

Sincerely,

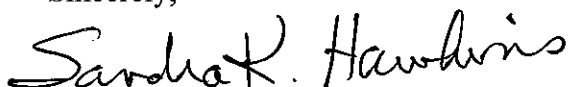

Sandra Hawkins

**Senior Client Account Manager**

**Authorized Contact**

Verizon

304-356-3395

[sandra.k.hawkins@verizonbusiness.com](mailto:sandra.k.hawkins@verizonbusiness.com)

Services provided by Verizon Select Services Inc., herein after referred to as ("Verizon") under this bid may be subject to tariff regulation by the Public Service Commission of West Virginia and/or the Federal Communications Commission. In addition and in compliance with the WV Purchasing Division's Policies and Procedures Handbook, Section 7.2.7, Verizon also submits additional terms and conditions reflected in Verizon's standard Verizon Service Agreement and Attachments, which is incorporated into Verizon's response. In addition, software provided is licensed to Customer under the license provided by the software publisher or by the equipment manufacturer with which the software is provided. Customer shall, if required, execute a separate software license agreement in a form satisfactory to the software publisher or equipment manufacturer. Unless specifically addressed within this bid response the terms and conditions set forth in this solicitation shall not add to, vary, or delete the terms and conditions of said tariffs or the Service Agreement. This response is submitted with the understanding that neither party shall be obligated to provide or purchase any of the services described herein until a mutual understanding is reached and the Agreement is signed by authorized individuals of both parties.

Verizon hereby submits the accompanying documentation and information in response to the State of West Virginia Request for Quotation ISCL004, for an Uninterruptible Power Supply due January 20<sup>th</sup> 2011. Verizon must provide a legal response and contractual documentation in accordance with the applicable State and Federal Regulatory Commissions.

**ISCL0048  
State of West Virginia – IS&C**

**Verizon has read, understands and will comply with all specifications of this RFQ to include Addendum 1 and 2. Upon award, all requirements under “Additional Services to be Provided by the Vendor” will be provided to the State.**

**In addition, Verizon has included a Statement of Work, System Agreement and Agreement Addendum (WV96). Please see the Appendix section for additional data sheets and specifications applicable to this response.**



State of West Virginia  
 Department of Administration  
 Purchasing Division  
 2019 Washington Street East  
 Post Office Box 50130  
 Charleston, WV 25305-0130

# Request for Quotation

RFQ NUMBER  
 ISCL0048

PAGE  
 1

ADDRESS CORRESPONDENCE TO ATTENTION OF  
 KRISTA FERRELL  
 304-558-2596

## RFQ COPY

TYPE NAME/ADDRESS HERE

Verizon Select Services Inc.  
 4700 MacCorkle Avenue, SE  
 Charleston, WV 25304

DEPARTMENT OF ADMINISTRATION  
 IS&C - COMMUNICATIONS  
 1900 KANAWHA BLVD. E.  
 BUILDING 5, 10TH FLOOR  
 CHARLESTON, WV  
 25305 304-558-5472

DATE PRINTED 12/10/2010	TERMS OF SALE	SHIP VIA	FOB	FREIGHT TERMS
----------------------------	---------------	----------	-----	---------------

BID OPENING DATE: 01/12/2011 BID OPENING TIME 01:30PM

LINE	QUANTITY	LOP	CAT NO	ITEM NUMBER	UNIT PRICE	AMOUNT
0001	1	EA		287-54		
THREE PHASE UNINTERRUPTIBLE POWER SUPPLY						
REQUEST FOR QUOTATION (RFQ)						
THE WEST VIRGINIA STATE PURCHASING DIVISION FOR THE AGENCY, THE WEST VIRGINIA OFFICE OF TECHNOLOGY, IS SOLICITING BIDS TO PROVIDE AND INSTALL ONE (1) NEW LEIBERT SERIES 80KVA NX THREE PHASE UNINTERRUPTIBLE POWER SUPPLY, MODEL 38SA081A0A00 (OR EQUAL) PER THE ATTACHED SPECIFICATIONS.						
TECHNICAL QUESTIONS MUST BE SUBMITTED IN WRITING TO KRISTA FERRELL IN THE WEST VIRGINIA STATE PURCHASING DIVISION VIA MAIL AT THE ADDRESS SHOWN IN THE BODY OF THIS RFQ, VIA FAX AT 304-558-4115, OR VIA EMAIL AT KRISTA.S.FERRELL@WV.GOV. DEADLINE FOR ALL TECHNICAL QUESTIONS IS WEDNESDAY, DECEMBER 22, 2010 AT THE CLOSE OF BUSINESS. ALL TECHNICAL QUESTIONS RECEIVED WILL BE ANSWERED BY FORMAL ADDENDUM TO BE ISSUED BY THE PURCHASING DIVISION AFTER THE DEADLINE HAS LAPSED.						
NOTICE TO PROCEED: THE INSTALLATION OF THE EQUIPMENT SHALL BE PERFORMED WITHIN 60 CALENDAR DAYS AFTER THE NOTICE TO PROCEED IS RECEIVED. THE RECEIVED PURCHASE ORDER SHALL SERVE AS THE NOTICE TO PROCEED.						
BANKRUPTCY: IN THE EVENT THE VENDOR/CONTRACTOR FILES FOR BANKRUPTCY PROTECTION, THE STATE MAY DEEM THE CONTRACT NULL AND VOID, AND TERMINATE SUCH CONTRACT WITHOUT FURTHER ORDER.						

SEE REVERSE SIDE FOR TERMS AND CONDITIONS

SIGNATURE <i>Patricia L Myers</i>	TELEPHONE 3043563395	DATE 1/14/11
TITLE Patricia L Myers Manager Pricing/Contract Management	FEIN 16-1337624	ADDRESS CHANGES TO BE NOTED ABOVE

IG TO RFQ, INSERT NAME AND ADDRESS IN SPACE ABOVE LABELED 'VENDOR'



State of West Virginia  
 Department of Administration  
 Purchasing Division  
 2019 Washington Street East  
 Post Office Box 50130  
 Charleston, WV 25305-0130

# Request for Quotation

RFQ NUMBER:  
**ISCL0048**

PAGE:  
**2**

ADDRESS CORRESPONDENCE TO ATTENTION OF:  
**KRISTA FERRELL  
 304-558-2596**

RFQ COPY  
 TYPE NAME/ADDRESS HERE

VENDOR

Verizon Select Services Inc.  
 4700 MacCorkle Avenue, SE  
 Charleston, WV 25304

SHIP TO

DEPARTMENT OF ADMINISTRATION  
 IS&C - COMMUNICATIONS  
 1900 KANAWHA BLVD. E.  
 BUILDING 5, 10TH FLOOR  
 CHARLESTON, WV  
 25305 304-558-5472

DATE PRINTED	TERMS OF SALE	SHIP VIA	FOB	FREIGHT TERMS
12/10/2010				

BID OPENING DATE: **01/12/2011** BID OPENING TIME: **01:30PM**

LINE	QUANTITY	UOP	CAT NO	ITEM NUMBER	UNIT PRICE	AMOUNT
<p><b>NOTICE</b></p> <p><b>A SIGNED BID MUST BE SUBMITTED TO:</b></p> <p>DEPARTMENT OF ADMINISTRATION            PURCHASING DIVISION            BUILDING 15            2019 WASHINGTON STREET, EAST            CHARLESTON, WV 25305-0130</p> <p><b>THE BID SHOULD CONTAIN THIS INFORMATION ON THE FACE OF THE ENVELOPE OR THE BID MAY NOT BE CONSIDERED:</b></p> <p><b>SEALED BID</b></p> <p>BUYER: KRISTA FERRELL-FILE 21</p> <p>RFQ. NO.: ISCL0048</p> <p>BID OPENING DATE: 01/12/2011</p> <p>BID OPENING TIME: 1:30 PM</p> <p>PLEASE PROVIDE A FAX NUMBER IN CASE IT IS NECESSARY TO CONTACT YOU REGARDING YOUR BID:            ----- <b>3043563590</b> -----</p> <p><b>CONTACT PERSON (PLEASE PRINT CLEARLY):</b></p>						

SEE REVERSE SIDE FOR TERMS AND CONDITIONS			
SIGNATURE <i>Patricia L Myers</i>	TELEPHONE <b>3043563395</b>	DATE <b>1/4/11</b>	
TITLE Patricia L Myers Manager Pricing/Contract Management	FEIN <b>16-1337624</b>	ADDRESS CHANGES TO BE NOTED ABOVE	

IG TO RFQ, INSERT NAME AND ADDRESS IN SPACE ABOVE LABELED 'VENDOR'



State of West Virginia  
 Department of Administration  
 Purchasing Division  
 2019 Washington Street East  
 Post Office Box 50130  
 Charleston, WV 25305-0130

# Request for Quotation

RFQ NUMBER  
 ISCL0048

PAGE  
 3

ADDRESS CORRESPONDENCE TO ATTENTION OF  
 KRISTA FERRELL  
 304-558-2596

RFQ COPY  
 TYPE NAME/ADDRESS HERE

VENDOR

Verizon Select Services Inc.  
 4700 MacCorkle Avenue, SE  
 Charleston, WV 25304

SHIP TO

DEPARTMENT OF ADMINISTRATION  
 IS&C - COMMUNICATIONS  
 1900 KANAWHA BLVD. E.  
 BUILDING 5, 10TH FLOOR  
 CHARLESTON, WV  
 25305 304-558-5472

DATE PRINTED	TERMS OF SALE	SHIP VIA	FOB	FREIGHT TERMS
12/10/2010				

BID OPENING DATE: 01/12/2011 BID OPENING TIME 01:30PM

LINE	QUANTITY	UOP	CAT NO	ITEM NUMBER	UNIT PRICE	AMOUNT
<i>SANDRA HAWKINS</i>						
***** THIS IS THE END OF RFQ ISCL0048 ***** TOTAL:						<u>\$123,492.41</u>

SEE REVERSE SIDE FOR TERMS AND CONDITIONS

SIGNATURE <i>Patricia L Myers</i>	TELEPHONE 3043563395	DATE 1/4/11
TITLE Patricia L Myers Manager Pricing/Contract Management	FEIN 16-1337624	ADDRESS CHANGES TO BE NOTED ABOVE

NG TO RFQ, INSERT NAME AND ADDRESS IN SPACE ABOVE LABELED 'VENDOR'

**West Virginia office of Technology  
Request for Quotation (RFQ)**

**The West Virginia Purchasing Division for the agency WVOT requests quotes to supply and install a new Liebert Series 80kVA Liebert NX Three Phase Uninterruptible Power Supply, model 38SA081A0A00, (or Equal) with the following related hardware and specifications:**

The system must include AC bypass voltage 208V (three-phase, three or four wire plus ground).

The system must include AC output voltage 208V (three phase, three or four wire plus ground).

The system must be equal to One (1) 80kVA Liebert NX Three Phase Uninterruptible Power Supply, model 38SA081A0A00, with the following features and characteristics:

The system must have Input Voltage 208VAC (3 wire plus ground) and must have system Output Voltage 208/120VAC (three phase, three or four-wire plus ground) and must include the following features:

- Integrated Load Bus Sync TM
- Softscale technology allows future upgrades up to 120kVA
- IGBT pulse-width modulated (PWM) rectifier providing 0.99 input power factor and 4% reflected input current distortion (THD)
- Temperature compensated separate battery charger to allow use with valve-regulated lead acid (VRLA), wet cell lead acid, and NiCad battery systems
- IGBT pulse-width modulated (PWM) Inverter
- Automatic continuous duty static transfer switch
- Single input, true on-line, double conversion
- Field Configurable for dual input (single module systems only)
- Internal manual bypass switch
- Withstand rating and UPS width: 65kAIC, UPS Module 25.5 inches wide
- Digital Signal Processing (DSP) control system
- Back-lit LCD Graphic Display with multilingual support and user friendly navigation menu
- Alarm History Database
- Redundant Cooling Fans
- Local EPO with provision for Remote EPO
- Three (3) Intellislot Communication Ports
- IP 20 enclosure



- Casters and leveling feet
- Meets ISTA 1B transportation requirements
- Meets FCC Part 15, Class A
- UL and cUL Listed to UL Standard 1778

The system **must** include 1 (One) IS-WEBLB: IntelliSlot Web Card LB. This interface card **must** deliver SNMP, Telnet and web-management capability for enhanced communications and control of Liebert UPS, Power Management or Precision Cooling systems. The card **must** manage a wide range of operating parameters, alarms and notifications, transmitting data over the network.

The system **must** include an External Battery System rated for 66 minutes at a 80kVA load and **must** have the following features:

- Two (2) External Battery Cabinet(s) model number: 38BP120XWX1BNS or equal
- Battery Cabinets are shipped separately and include side panels.
  - Battery interconnect cable kit type: Left Side of UPS
  - Battery Cabinet cable kits include DC wiring as well as control interface wiring.

The system **must** include a Liebert Bypass Distribution Cabinet, model FXC12C6NNG6, or equal with the following features:

- 3-Breaker wrap-around maintenance bypass with interlock by solenoid key release unit (SKRU)
- Distribution, Width and Access Requirements: (2) 225A Breakers, 47in Wide, Front & Rear Access
- Casters and leveling feet

And **shall** include interconnecting cables for bolting the Bypass Distribution cabinet to the right side of the UPS

**UPS System Start-up Services, must** including the following:

Start-up includes one site trip by a LGS customer engineer after the UPS has been installed. The site trip **must** include the following services for one UPS module: non-powered inspection UPS electrical and operational checkout, full parts and labor for any remedial work required on the UPS or battery cabinets, and customer operation training. Start-up also **must** include remedial onsite labor, parts, and travel for the full one-year warranty period.

Startup **shall** be scheduled at the customers designated time.

#### **ADDITIONAL SERVICES TO BE PROVIDED BY THE VENDOR**

The vendor **must** describe any power interruptions necessary for the installation of this hardware. If it is found necessary for an additional power outage to

occur, the Data Center Manager **must** be notified at least two weeks before the occurrence. The vendor **must** submit a schedule of dates and times of interruptions in advance so that we can have adequate time to notify end-users.

The vendor **shall** be responsible for all necessary permits, licenses, and inspections as required.

The vendor **shall** be responsible for the maintenance and warranty for all hardware and labor by maintaining a 24/7 helpline for technical issues for the period of one year after installation. A live attendant **shall** be on site within 4 hours from a trouble call being placed.

The vendor **shall** provide training to designated State personnel (not to exceed 6 employees) on the operations of all hardware.

All installation **shall** be completed within 60 day after receiving of purchase order.

#### **INSTALLATION ADDRESS**

**This System is to be installed at the Disaster Recovery Center located at 89 Richard D. Munnich Dr., Sutton WV.**

#### **HOURS OF WORK**

The normal working hours for the Office of Technology are 7:30 AM to 5:00 PM, Monday through Friday. However, designated State holidays, weekends, and after hours schedules will be accommodated if given advance notice and permission by the Office of Technology.

#### **PERSONNEL**

The Vendor **shall** submit a proposed staffing plan including supervisory personnel to accomplish this work in the designated time frame.

#### **EQUAL EMPLOYMENT OPPORTUNITY**

The successful vendor **must** be an Equal Opportunity Employer, and **shall** take all employment actions without regard to an individual's race, color, national origin, ancestry, sex, religion, age, physical handicap, disability, or political affiliation.

## **CONDUCT AND MANAGEMENT**

While employed on this contract, all personnel will remain employees of the vendor. The vendor shall make this condition clearly known to his or her employees and shall be responsible for their conduct and management. The State of West Virginia shall not be considered a re-employer. If a vendor employee displays improper work conduct, unsatisfactory performance, or is deemed to be unqualified to perform the assignment, the Office of Technology may request a replacement employee from the vendor. The Vendor shall be solely responsible for conformity with all applicable health, safety and sanitation standards, laws and regulations at the State's facilities.

## **SMOKE FREE / DRUG FREE / ALCOHOL FREE**

In keeping with the policies of the State of West Virginia, the Vendor must maintain a drug free / alcohol free work environment.

## **IMMIGRATION REFORM AND CONTROL ACT OF 1986**

By submitting this response, the vendor certifies that it does not and will not, during the performance of the contract, employ illegal alien workers or otherwise violate the provisions of the Federal Immigration Reform and Control Act of 1986.

## **METHOD OF PAYMENT / COMPENSATION**

After all work has been satisfactorily completed and accepted by the State of West Virginia as outlined in this contract, the vendor shall transmit an invoice for payment in the amount of the original purchase order. The vendor shall be responsible for all salaries, wages, and related costs. The vendor will be responsible for paying any and all insurance, taxes, overtime, holiday pay, and other unnamed payroll costs, which may arise. If the contractor has not completed the work within the prescribed time frame, the contractor shall be assessed liquidated damages until the work is completed. Liquidated damages shall comprise of a daily penalty of five (5) percent of the total contract award per day until the work is satisfactorily completed.

## **SUPPORT**

The Office of Technology will have an employee available during all installation. Additionally, the Office of Technology will provide a list of contact and support personnel that will be available to the vendor.

By signing below, vendor certifies that all specifications will be followed, that vendor meets all criteria, and will adhere to the schedule if awarded the purchase order.

Total Cost Quote: \$ 123,492.41

Patricia L Myers  
Manager  
Pricing/Contract Management

Patricia Myers  
Signature/ Title

Verizon Business Services Inc. on  
behalf of Verizon Select Services Inc.  
Vendors Name

**AGREEMENT ADDENDUM**

In the event of conflict between this addendum and the agreement, this addendum shall control:

1. **DISPUTES** - Any references in the agreement to arbitration or to the jurisdiction of any court are hereby deleted. Disputes arising out of the agreement shall be presented to the West Virginia Court of Claims.
2. **HOLD HARMLESS** - Any clause requiring the Agency to indemnify or hold harmless any party is hereby deleted in its entirety.
3. **GOVERNING LAW** - The agreement shall be governed by the laws of the State of West Virginia. This provision replaces any references to any other State's governing law.
4. **TAXES** - Provisions in the agreement requiring the Agency to pay taxes are deleted. As a State entity, the Agency is exempt from Federal, State, and local taxes and will not pay taxes for any Vendor including individuals, nor will the Agency file any tax returns or reports on behalf of Vendor or any other party.
5. **PAYMENT** - Any references to prepayment are deleted. Payment will be in arrears.
6. **INTEREST** - Should the agreement include a provision for interest on late payments, the Agency agrees to pay the maximum legal rate under West Virginia law. All other references to interest or late charges are deleted.
7. **RECOUPMENT** - Any language in the agreement waiving the Agency's right to set-off, counterclaim, recoupment, or other defense is hereby deleted.
8. **FISCAL YEAR FUNDING** - Service performed under the agreement may be continued in succeeding fiscal years for the term of the agreement, contingent upon funds being appropriated by the Legislature or otherwise being available for this service. In the event funds are not appropriated or otherwise available for this service, the agreement shall terminate without penalty on June 30. After that date, the agreement becomes of no effect and is null and void. However, the Agency agrees to use its best efforts to have the amounts contemplated under the agreement included in its budget. Non-appropriation or non-funding shall not be considered an event of default.
9. **STATUTE OF LIMITATION** - Any clauses limiting the time in which the Agency may bring suit against the Vendor, lessor, individual, or any other party are deleted.
10. **SIMILAR SERVICES** - Any provisions limiting the Agency's right to obtain similar services or equipment in the event of default or non-funding during the term of the agreement are hereby deleted.
11. **ATTORNEY FEES** - The Agency recognizes an obligation to pay attorney's fees or costs only when assessed by a court of competent jurisdiction. Any other provision is invalid and considered null and void.
12. **ASSIGNMENT** - Notwithstanding any clause to the contrary, the Agency reserves the right to assign the agreement to another State of West Virginia agency, board or commission upon thirty (30) days written notice to the Vendor and Vendor shall obtain the written consent of Agency prior to assigning the agreement.
13. **LIMITATION OF LIABILITY** - The Agency, as a State entity, cannot agree to assume the potential liability of a Vendor. Accordingly, any provision limiting the Vendor's liability for direct damages to a certain dollar amount or to the amount of the agreement is hereby deleted. Limitations on special, incidental or consequential damages are acceptable. In addition, any limitation is null and void to the extent that it precludes any action for injury to persons or for damages to personal property.
14. **RIGHT TO TERMINATE** - Agency shall have the right to terminate the agreement upon thirty (30) days written notice to Vendor. Agency agrees to pay Vendor for services rendered or goods received prior to the effective date of termination.
15. **TERMINATION CHARGES** - Any provision requiring the Agency to pay a fixed amount or liquidated damages upon termination of the agreement is hereby deleted. The Agency may only agree to reimburse a Vendor for actual costs incurred or losses sustained during the current fiscal year due to wrongful termination by the Agency prior to the end of any current agreement term.
16. **RENEWAL** - Any reference to automatic renewal is hereby deleted. The agreement may be renewed only upon mutual written agreement of the parties.
17. **INSURANCE** - Any provision requiring the Agency to insure equipment or property of any kind and name the Vendor as beneficiary or as an additional insured is hereby deleted.
18. **RIGHT TO NOTICE** - Any provision for repossession of equipment without notice is hereby deleted. However, the Agency does recognize a right of repossession with notice.
19. **ACCELERATION** - Any reference to acceleration of payments in the event of default or non-funding is hereby deleted.
20. **CONFIDENTIALITY** - Any provision regarding confidentiality of the terms and conditions of the agreement is hereby deleted. State contracts are public records under the West Virginia Freedom of Information Act.
21. **AMENDMENTS** - All amendments, modifications, alterations or changes to the agreement shall be in writing and signed by both parties. No amendment, modification, alteration or change may be made to this addendum without the express written approval of the Purchasing Division and the Attorney General.

**ACCEPTED BY:**  
**STATE OF WEST VIRGINIA** \_\_\_\_\_

Spending Unit: \_\_\_\_\_

Signed: \_\_\_\_\_

Title: \_\_\_\_\_

Date: \_\_\_\_\_

**VENDOR** Verizon Business Network Services  
Inc. on behalf of Verizon Select  
Company Name: Services Inc.

Signed: Patricia L Myers

Title: \_\_\_\_\_  
**Patricia L Myers**  
Manager  
Pricing/Contract Management

Date: 7/4/11

This System Agreement ("Agreement"), effective as of the \_\_\_\_ day of \_\_\_\_, 20 \_\_\_\_, is made by and between

Verizon Entity Name ("Verizon"): Verizon Business Network Services Inc. on behalf of Verizon Select Services Inc.	<b>B. Customer Name ("Customer")</b>  State of West Virginia, IS& C
Address: 4700 MacCorkle Avenue, SE	Address: 1800 Kanawha Blvd, East, Building 5, 10 <sup>th</sup> Fl
City: Charleston State: WV Zip Code: 25304	City: Charleston State: WV Zip Code: 25305
Contact Name and Phone Number: Sandra Hawkins 304-356-3395	Customer Billing Address (if different):
Quote Number (if applicable) _____	City: State: Zip Code:
	Contact Name and Phone Number: Krista Ferrell 304-558-5472

<p><b>C. Select all applicable options:</b></p> <p><input checked="" type="checkbox"/> New System/Service Sale  <input type="checkbox"/> Adds/Upgrade to Existing System  <input type="checkbox"/> Installation Services  <input type="checkbox"/> International Purchase and Sale (Drop Ship)</p> <p><b>VERIZON MAINTENANCE SERVICES</b></p> <p><input type="checkbox"/> IP PBX Supplemental  <input type="checkbox"/> 8x5 Switch &amp; Phones  <input type="checkbox"/> 8x5 Switch &amp; Proprietary Phones  <input type="checkbox"/> 8x5 Switch Only  <input type="checkbox"/> 8x5 Ancillary/Auxiliary Equipment  <input type="checkbox"/> 8x5 Nortel Norstar  <input type="checkbox"/> 8x5 NEC Electra Elite  <input type="checkbox"/> 8x5 Business Communication Manager  <input type="checkbox"/> 8x5 Centrex CPE  <input type="checkbox"/> 24x7 Switch &amp; Proprietary Phones  <input type="checkbox"/> 24x7 Switch Only  <input type="checkbox"/> 24x7 Ancillary/Auxiliary Equipment  <input type="checkbox"/> 24x7 Nortel Norstar  <input type="checkbox"/> 24x7 NEC Electra Elite  <input type="checkbox"/> 24x7 Business Communication Manager  <input type="checkbox"/> 24x7 Voice Service Plus  <input type="checkbox"/> 24x7 Centrex CPE  <input type="checkbox"/> Software Release Subscription (SRS)</p>	<p><b>Verizon Maintenance Services Cont'd.</b></p> <p><input type="checkbox"/> On-Site Technician  <input type="checkbox"/> Supplemental Warranty Coverage (extends the standard warranty to 24 hour coverage for major failures during the warranty period)  <input type="checkbox"/> Other</p> <p><b>Third Party Maintenance Services</b> – Third party maintenance will be provided in accordance with (i) the service descriptions of the respective third party maintenance service providers (generally available on their respective websites) and (ii) the relevant terms and conditions of this Agreement, specifically excluding section 3.2 (termination for convenience).</p> <p><input type="checkbox"/> Nortel Extended Service  <input type="checkbox"/> Cisco SMARTnet  <input type="checkbox"/> Other:</p>
--	---



D. Payment Options:

- Cash Purchase
- Lease/Financing
  - Verizon Credit Inc.
  - Third Party Lease/Financing \_\_\_\_\_ (must have prior written approval of Verizon)
- E-Rate/USF Funding Application No. \_\_\_\_\_
- Tax Exempt No. \_\_\_\_\_

E. The total price of the System and/or services being purchased by the Customer is:

Equipment and/or Installation Price \$ 123,492.41

Professional Services Price \$ \_\_\_\_\_

Maintenance Service

Voice Maintenance Service for \_\_\_\_\_ Year(s) \$ \_\_\_\_\_

Third Party Maintenance Service for \_\_\_\_\_ Year(s) \$ \_\_\_\_\_

Supplemental Warranty Coverage \$ \_\_\_\_\_

Applicable taxes (estimated) \$ \_\_\_\_\_

**TOTAL PRICE** \$ 123,492.41

F. Maintenance Service Billing Option:

- Pre-paid Billing: \_\_\_\_\_ years \$ \_\_\_\_\_ (Annual Rate)
- Deferred Billing (deferred until warranty expiration):  
 \_\_\_\_\_ years \$ \_\_\_\_\_ \$ \_\_\_\_\_ \$ \_\_\_\_\_ \$ \_\_\_\_\_  
 (Year 1) (Year2) (Year 3) (Year 4) (Year 5)

Bill deferred payment (check one):  annually  semi-annually  quarterly  monthly

G. Attachments

- Avaya Equipment, Maintenance and Professional Services Exhibit
- Call Center Software, Support and Professional Services Exhibit
- Cisco Technology Migration Program Supplement
- Equipment Sales and Installation Exhibit
- E-Rate Funding Related Terms and Conditions
- International Purchase and Sale Exhibit
- PBX Mobile Extension
- Professional Services Exhibit
- Quote
- Service Plan Description(s)
- Statement of Work
- Statement of Work (Avaya)
- Voice Maintenance Exhibit

THE TERMS AND CONDITIONS OF THIS AGREEMENT CONTINUE ON THE FOLLOWING PAGES

Customer Initials



## System Agreement

**1. Scope of Agreement.** Subject to the terms and conditions of this Agreement, Verizon will provide Customer, either directly or in conjunction with such subcontractors as it may select, the equipment, software, installation services, maintenance (hereinafter collectively the "System") and/or professional services as described in this Agreement and as further described in a Statement of Work and any Exhibit attached hereto.

**1.1 For Equipment Sale and Installation Services:** Verizon will provide and, if applicable, install the equipment as set forth in the applicable quote and the Equipment and Installation Services Exhibit.

**1.2 For Maintenance Services:** Verizon will provide the maintenance services as set forth in the applicable quote and the Call Center Software, Support and Professional Services Exhibit, and/or the Maintenance Services Exhibit. The foregoing exhibits do not apply to maintenance services provided by a third party. Third party maintenance will be provided in accordance with (i) the service descriptions of the respective third party maintenance service providers (generally available on their respective websites) and (ii) the relevant terms and conditions of this Agreement, specifically excluding section 3.2 (termination for convenience).

**1.3 For Professional Services:** Verizon will provide the professional services as set forth in the applicable quote and the Professional Services Exhibit.

All applicable Statements of Work and Exhibits attached hereto are incorporated herein and made a part of this Agreement.

## **2. Fees and Payment.**

**2.1** Customer will pay all fees for the System as set forth on Pages 2 of this Agreement and the applicable quote or Statement of Work, subject to additions and deductions made by written Change Order(s). Customer is responsible for applicable taxes, shipping, handling, telecommunication surcharges and other charges applicable to the equipment and/or services provided under this Agreement. Customer agrees either to pay to Verizon the amount of all applicable taxes or to provide upon execution of this Agreement evidence of exemption acceptable to Verizon.

**2.2** Payments are due within thirty (30) days of receipt of the invoice ("Due Date") and any payment not received by the Due Date shall be subject to a late payment charge of the lesser of one and one-half percent (1.5%) per month and the maximum amount allowed by law. Late payment charges will be assessed monthly against the amount due. Should Customer dispute an amount invoiced, Customer shall pay the undisputed portion of that invoice and promptly notify Verizon in writing of the amount and nature of the dispute and the parties shall cooperate to resolve the dispute pursuant to Section 15 of this Agreement. Verizon reserves the right to suspend or terminate any or all services or terminate the provision, installation or repair of any or all equipment subject to this Agreement immediately if Customer is more than sixty (60) days overdue for payments that have not been disputed in good faith.

**2.3** The down payment listed on Page 2 of this Agreement shall be paid at execution of this Agreement. The balance due shall be paid in accordance with the terms of this Section unless otherwise specified in a Statement of Work.

**3. Term and Termination.** This Agreement shall be effective as of the date first set forth above and shall continue in full force and effect until terminated in accordance with this Agreement.

**3.1.** Either party may, upon written notice, immediately suspend its performance of and/or terminate the affected service or equipment order to which the deficiency pertains in the event the other party (i) fails to perform material terms of this Agreement and (a) such failure is not cured within thirty (30) calendar days following receipt of a default notice in writing from the other party, or (b) if such failure cannot reasonably be cured during that time and the defaulting party fails to use commercially reasonable efforts to cure such breach as soon as practicable, but in any event within ninety (90) calendar days following written notice; (ii) engages in fraud, criminal conduct or willful misconduct in connection with the business relationship of the parties; or (iii) becomes insolvent, ceases doing business in the ordinary course, enters bankruptcy proceedings or effects an assignment for the benefit of creditors. In the event Verizon terminates this Agreement pursuant to this Section 3.1, Customer shall promptly pay Verizon for the System and any services provided up to the date of termination. In the event Customer defaults under this Agreement, Customer's down payment shall be non-refundable.





## System Agreement

3.2. Either party may terminate this Agreement or a Statement of Work for convenience, in whole or in part, upon thirty (30) days prior written notice to the other party. If this Agreement or a Statement of Work is terminated by Customer pursuant to this Section, or if an order under this Agreement is cancelled by Customer, Verizon shall have no further responsibility under this Agreement, Statement of Work or such order, as applicable, and Customer shall promptly pay Verizon:

3.2.1. for all equipment and services provided up to the date of termination or cancellation, as applicable;

3.2.2. for all expenses incurred up to the date of termination or cancellation, as applicable, including but not limited to the costs of terminating purchase orders, return of equipment and/or software (if permitted by Verizon), removal of equipment and/or software and other contractual obligations made by Verizon to meet its obligations under this Agreement or Statement of Work, plus a restocking fee of twenty-five percent (25%) of the cost of any equipment cancelled or returned.

3.3. Where multiple Statements of Work are associated with this Agreement, the termination of one or fewer than all of the Statements of Work shall only affect the terminated Statement(s) of Work. The remaining Statement(s) of Work shall remain in effect. Termination of the Agreement shall not affect any maintenance service in effect at the time of termination and such service shall continue until expiration thereof under the terms of this Agreement as if the Agreement was still in effect.

3.4. Verizon reserves the right to suspend performance under this Agreement or a Statement of Work if required, in Verizon's sole discretion, by regulation, statute, judicial action or other applicable legal requirement.

3.5. Verizon reserves the right to amend the rates, terms and conditions of service under this Agreement to be effective upon the commencement of any renewal term and without formal amendment of this Agreement by providing Customer written notice thereof prior to the expiration of the then-current term. If Customer is unwilling to accept such amended rates, terms and conditions, Customer shall provide Verizon written notice thereof prior to the expiration of the then-current term, in which event the service shall terminate upon expiration of the then-current term.

3.6. Termination of this Agreement shall not relieve either party of its respective obligations to comply with all terms of this Agreement that expressly call for performance prior or subsequent to the termination date, including without limitation the parties' respective obligations to protect proprietary and confidential information.

**4. Purchase Order.** The parties acknowledge that a Customer purchase order or similar document is intended solely to evidence Customer's intention to purchase equipment, software and/or services set forth therein. Except with respect to a provision in a Customer purchase order or similar document evidencing an intent to be bound by the terms and conditions of an Agreement between Customer and Verizon, the terms and conditions of such Customer purchase order or similar document shall be disregarded and of no force or effect, it being agreed that the terms and conditions of the Agreement between Customer and Verizon shall govern.

**5. Leasing Option.** With Verizon's prior written consent Customer may finance the System or any portion thereof in a separate transaction through a third party leasing company ("Lessor") approved by Verizon, assign its rights and obligations with respect to payment under this Agreement to the Lessor, and/or cause the Lessor to issue a purchase order in a form acceptable to Verizon. Notwithstanding such transaction and/or assignment, Customer shall remain responsible for performance of all of its obligations under this Agreement, including payment in full.

**6. Risk of Loss.** If Verizon installs the System, risk of loss or damage to the System passes to Customer on delivery of the System (including portions thereof) to Customer's site. If Verizon does not install the System, risk of loss or damage to the System (or portions thereof) passes to Customer upon delivery to the carrier.

**7. Title and Security Interest.** Until full payment has been rendered, Customer grants Verizon a purchase money security interest in the System, and agrees to execute all documents necessary to perfect that interest. Upon final payment, title shall pass to Customer and Verizon will release its security interest. Customer will not grant or convey to any other person or entity a security interest in, or permit placement of a lien on, the System unless and until Customer has paid Verizon in full for such System.

**8. Software.** Software provided in conjunction with the System is licensed to Customer under the license provided by the software publisher or by the equipment manufacturer with which the software is provided.



## System Agreement

Customer shall, if required, execute a separate software license agreement in a form satisfactory to the software publisher or equipment manufacturer.

### 9. Customer Responsibilities. Customer will:

- 9.1. Allow Verizon access for installation, inspection, testing, maintenance and repair of the System and performance of any required activity.
- 9.2. Provide suitable building facilities for the System in accordance with local codes, including but not limited to ducting, conduit, structural borings, etc. for cable and conductors in floors, ceilings and walls; electrical service with suitable terminals and power surge protection devices; and metallic grounds with sufficient slack in the equipment room, installed in conformity with the National Electrical Code and local codes.
- 9.3. Provide necessary heating, cooling, humidity and dust control as required by manufacturer specifications.
- 9.4. Remove existing equipment or cable that interferes with System installation.
- 9.5. Identify and disclose to Verizon concealed equipment, wiring or conditions that might be affected by or might affect the installation of the System. Customer shall defend and hold Verizon harmless from any claim, damage or liability resulting from a failure to disclose this information.
- 9.6. Authorize Verizon, at Customer's expense, to make service requests upon third parties for System interconnection requirements, including obtaining telephone service for testing where necessary.
- 9.7. Designate trash deposit points on each floor on which the System is to be installed where Verizon will place waste for removal by Customer.
- 9.8. Cooperate with Verizon's requests for assistance in testing or installation.
- 9.9. Be responsible for providing adequate back-up of data and for restoring data to repaired equipment.
- 9.10. If the System is to be connected to the public network, be solely responsible for selection, implementation and maintenance of security features for defense against unauthorized long distance calling, and for payment of long distance, toll and other telecommunications charges incurred through use of the System.
- 9.11. Immediately notify Verizon of any anticipated delay in building availability or inability to meet any of the above listed requirements.
- 9.12. If ordering Cisco Products or services, acknowledge having read and understand the End User obligations and service descriptions for relevant Cisco products and services as found at [www.cisco.com/go/servicedescriptions](http://www.cisco.com/go/servicedescriptions) or other URL as may be provided by Cisco from time to time. Further, Customer agrees to the terms and conditions of Cisco's Software License Agreement.

### 10. Changes In/Additions to System.

10.1 Customer may order additional equipment, software, and/or services pursuant to a written Amendment, Customer purchase order or similar document, and such order shall be governed by this Agreement, including without limitation Section 4, and shall specifically reference this Agreement.

10.2 Customer shall also have the right, by written notice, to propose changes in the System under this Agreement and any Statement of Work ("Change Orders") and Verizon shall comply to the extent it deems feasible and reasonable. If Verizon determines that such changes cause an increase or decrease in the cost of or time required for performance, Verizon shall advise Customer and such adjustments shall be reflected in a written Change Order. Should Verizon encounter, in installing the System, any concealed or unknown condition not expressly set forth in the applicable Statement of Work, which condition affects the price or schedule for installation of the System, the price and/or the schedule shall be equitably adjusted by Change Order to cover all costs, including but not limited to labor, equipment, materials and tools necessary to carry out the change.

10.3 No Change Order shall become effective as a part of this Agreement and the applicable Statement of Work, and no changes in the System shall be initiated, until the Change Order is mutually agreed upon in writing. Verizon shall not be obligated to consider or accept any Change Order that results in a decrease of more than twenty percent (20%) in the total price of the System. Verizon may also propose changes in or additions to the System, and may proceed with such changes upon execution by Customer and Verizon of a written Change Order.

11. **Warranty.** Verizon warrants that it will perform the services provided under this Agreement in a good and workmanlike manner. Unless otherwise set forth in an Exhibit, all manufacturers'/publishers' warranties for equipment and/or software provided hereunder are passed through to Customer and warranty claims shall be presented by Customer directly to the manufacturer/publisher.



## System Agreement

THE WARRANTIES SET FORTH IN THIS AGREEMENT ARE IN LIEU OF ALL OTHER WARRANTIES FROM VERIZON, UNLESS OTHERWISE STATED IN AN EXHIBIT. OTHERWISE VERIZON DISCLAIMS ALL WARRANTIES, EXPRESS OR IMPLIED, INCLUDING BUT NOT LIMITED TO IMPLIED WARRANTIES OF MERCHANTABILITY AND FITNESS FOR A PARTICULAR PURPOSE, ANY WARRANTY OF NON-INFRINGEMENT AND ANY WARRANTIES ARISING FROM A COURSE OF DEALING, USAGE OR TRADE PRACTICE. VERIZON SHALL NOT BE LIABLE FOR UNAUTHORIZED ACCESS TO VERIZON'S OR CUSTOMER'S TRANSMISSION FACILITIES OR PREMISES EQUIPMENT OR FOR UNAUTHORIZED ACCESS TO OR ALTERATION, THEFT OR DESTRUCTION OF CUSTOMER'S DATA FILES, PROGRAMS, PROCEDURES OR INFORMATION THROUGH ACCIDENT, FRAUDULENT MEANS OR DEVICES, OR ANY OTHER METHOD. VERIZON MAKES NO WARRANTY FOR USE OF THE SYSTEM AS A COMPONENT IN LIFE SUPPORT SYSTEMS OR DEVICES, PUBLIC SAFETY SYSTEMS, OR WITH RESPECT TO THE PERFORMANCE OF ANY SOFTWARE OR FIRMWARE.

**12. Limitation of Liability.** EXCEPT FOR PAYMENTS OWED UNDER THIS AGREEMENT, IN NO EVENT WILL EITHER PARTY BE LIABLE TO THE OTHER PARTY FOR SPECIAL, INDIRECT, INCIDENTAL, EXEMPLARY, OR CONSEQUENTIAL DAMAGES, WHETHER ARISING IN CONTRACT, TORT (INCLUDING A PARTY'S NEGLIGENCE) OR OTHERWISE, INCLUDING WITHOUT LIMITATION DAMAGES ARISING FROM DELAY, LOSS OF GOODWILL, LOSS OF OR DAMAGE TO DATA, LOST PROFITS (ACTUAL OR ANTICIPATED), UNAVAILABILITY OF ALL OR PART OF THE SYSTEM, OR OTHER COMMERCIAL OR ECONOMIC LOSS, EVEN IF SUCH PARTY HAS BEEN ADVISED OF THE POSSIBILITY OF SUCH DAMAGES.

EXCEPT WITH RESPECT TO THE INDEMNIFICATION OBLIGATIONS SET OUT IN SECTION 13, VERIZON'S ENTIRE LIABILITY FOR ANY OTHER DAMAGE WHICH MAY ARISE HEREUNDER, FOR ANY CAUSE WHATSOEVER, AND REGARDLESS OF THE FORM OF ACTION, WHETHER IN CONTRACT OR IN TORT, INCLUDING VERIZON'S NEGLIGENCE, OR OTHERWISE, SHALL BE LIMITED TO DIRECT DAMAGES NOT TO EXCEED THE PURCHASE PRICE OF THE SPECIFIC EQUIPMENT, SOFTWARE OR SERVICES GIVING RISE TO THE CLAIM. VERIZON SHALL BEAR NO LIABILITY FOR USE OF EQUIPMENT, SOFTWARE OR SERVICES PROVIDED UNDER THIS AGREEMENT IN CONNECTION WITH LIFE SUPPORT SYSTEMS OR DEVICES OR PUBLIC SAFETY SYSTEMS. EXCEPT AS EXPRESSLY STATED OTHERWISE HEREIN, VERIZON SHALL HAVE NO LIABILITY OR RESPONSIBILITY FOR INTEROPERABILITY OR COMPATIBILITY OF THE SYSTEM WITH THIRD-PARTY PRODUCTS OR SYSTEMS THAT CUSTOMER MAY UTILIZE IN CONJUNCTION WITH THE SYSTEM OR TO WHICH CUSTOMER MAY CONNECT THE SYSTEM.

### **13. Indemnification and Defense.**

13.1 Except as provided below, Verizon will defend Customer against any claim, suit, action or proceeding alleging that equipment supplied by Verizon to Customer under this Agreement ("Verizon supplied equipment") infringes a valid U.S. patent or copyright ("Claim"), and Verizon will indemnify and hold harmless Customer against any and all finally awarded costs and expenses, including attorneys' fees, in connection with any such Claim.

13.2 If the use of any Verizon supplied equipment is enjoined or subject to a Claim as described above, Verizon may, at its option and expense, either procure for Customer the right to continue to use the equipment, replace the equipment, or relevant component, with substantially equivalent, non-infringing equipment, or relevant component, or modify the equipment, or relevant component, so that it becomes non-infringing. In the event that none of the foregoing options is commercially reasonable to Verizon, Verizon will remove the infringing Verizon supplied equipment and refund to Customer the purchase price for the equipment less depreciation for its use. Depreciation shall be calculated on a straight-line basis, assuming a useful life of five (5) years.

13.3 Verizon shall have no obligation for (a) any costs, fees or expenses incurred by Customer without Verizon's prior written consent; (b) any allegation, assertion, or claims of intellectual property infringement, including contributory infringement or inducement to infringe, arising out of or related to any Claim involving: (i) automated call processing, automated voice service, automated customer service or combined live operator/automated systems processing used in processing or completing calls, (ii) automated bridging of more than two callers utilizing some form of "listen only" (unilateral) communication combined with some form of interactive communication, (iii)



## System Agreement

prepaid calling products or services, (iv) wireless telecommunications services or support therefor, or (v) "music on hold" service; or (c) any indirect, special, consequential or incidental damages arising out of any Claim.

13.4 Any obligation on the part of Verizon to defend and indemnify shall not apply to any Claim or portion thereof that arises from (i) any negligent or willful act or omission by or attributable to Customer; (ii) use or operation of the Verizon supplied equipment in combination with equipment or services provided by Customer or any third party; (iii) any addition to or modification of the Verizon supplied equipment by Customer, any third party or Verizon at Customer's request; (iv) use of other than the then current unaltered release of any software used in the Verizon supplied equipment; or (v) any equipment, system, product, process, method or service of Customer which otherwise infringed the U.S. patent or copyright asserted against Customer prior to the supply of the equipment to Customer by Verizon under the Agreement.

13.5 The foregoing states the entire obligation of Verizon to Customer and is Customer's sole and exclusive remedy with respect to any Claim of infringement of any intellectual property right of any kind, and Verizon disclaims all other warranties and obligations with respect to any such Claims.

13.6 Customer shall defend, indemnify and hold harmless Verizon, its employees, officers, directors, agents and affiliates for damages, costs and attorneys fees in connection with any claim arising out of (a) Customer's use of the equipment provided by Verizon other than as expressly indemnified by Verizon pursuant to Section 13.1 of this Agreement, (b) combination of the equipment provided by Verizon with other equipment, software, products or services not provided by Verizon under this Agreement, (c) modification of the equipment provided by Verizon, or (d) arising out of the content of communications transmitted by or on behalf of Customer in the use of the services or equipment provided by Verizon, including but not limited to libel, slander, and invasion of privacy.

13.7 Each party (the "indemnitor") shall defend, indemnify, and hold harmless the other party (the "indemnitee") against all claims and liabilities for direct damages imposed on the indemnitee for bodily injuries, including death, and for damages to real or tangible personal property to the extent caused by the negligent or otherwise tortious acts or omissions of the indemnitor, its agents or employees in the course of performance of this Agreement.

13.8 The defense and indemnification obligations set forth in this Section 13 are contingent upon (1) the indemnitee providing the indemnitor prompt, written, and reasonable notice of the claims, demands, and/or causes of action subject to indemnification, (2) the indemnitee granting the indemnitor the right to control the defense of the same, and (3) the indemnitee's full cooperation with the indemnitor in defense of the claim, including providing information and assistance in defending the claim. Nothing herein, however, shall restrict the indemnitee from participating, on a non-interfering basis, in the defense of the claim, demand, and/or cause of action at its own cost and expense with counsel of its own choosing. No settlement may be entered into by the indemnitor on behalf of the indemnitee that includes obligations to be performed by the indemnitee (other than payment of money that will be fully paid by the indemnitor under Sections 13.1- 13.7 above) without indemnitee's prior written approval.

**14. Confidentiality.** Except as required by law or regulation, each party (the "receiving party") shall keep confidential and not disclose, directly or indirectly, to any third party any Confidential Information, as defined below, received from the other party (the "disclosing party") without the prior written consent of a duly authorized officer of the disclosing party. The disclosing party shall conspicuously mark its tangible Confidential Information as Proprietary or Confidential at the time of disclosure to the receiving party. Confidential Information that is disclosed orally will be identified by the disclosing party as Confidential Information at the time of disclosure to the receiving party. Each party shall use, copy and disclose the Confidential Information of the disclosing party solely for purposes of performing this Agreement. All Confidential Information of a party shall be and shall remain the property of such party. A party shall deliver to the disclosing party, upon written request by the disclosing party, all Confidential Information of the disclosing party then in the receiving party's possession or control, directly or indirectly, in whatever form it may be (including, without limitation, magnetic media) or certify its destruction to the disclosing party. Each party shall take all necessary and reasonable action, by instruction, agreement or otherwise, with its employees, consultants, subcontractors, affiliates, and representatives to satisfy its obligations hereunder. The receiving party's obligations hereunder with respect to confidentiality, non-disclosure and limitation of use of Confidential Information shall be for the term of the Agreement plus one (1) year. For purposes of this provision, a third party shall not include an entity which has a need to know the Confidential Information and which owns, is owned by, or is under common ownership with a party to this Agreement.



## System Agreement

14.1 Nothing in this Agreement shall prevent either party from using or disclosing any Confidential Information that: (i) has become generally available to the public, other than through any improper action of such party, (ii) is already in the possession of the receiving party and not subject to an existing agreement of confidence between the parties, (iii) is received from a third party without restriction and without breach of this Agreement, (iv) is independently developed by the receiving party as evidenced by its records, or (v) is disclosed pursuant to a valid law, rule, regulation, subpoena, demand, or order of a court or other governmental body or any political subdivision thereof of competent jurisdiction (collectively "demand"); provided, however, that the receiving party shall first have given notice thereof to the disclosing party (unless prohibited by the terms of such request or requirement, or such notice is otherwise prohibited by law) in order to permit the disclosing party to seek reasonable protective arrangements.

14.2 For purposes of this Agreement, the term "Confidential Information" shall include, without limitation, all trade secrets of a party and all other information and material that relates or refers to the plans, policies, finances, corporate developments, products, pricing, sales, services, procedures, intra-corporate transactions, suppliers, prospects and customers of a party, as well as financial information relating to such suppliers, prospects and customers, and any other similar confidentiality information and material which such party does not make generally available to the public. By way of illustration, but not limitation, Confidential Information includes all computer software (including object code and source code), computer software and data base technologies, systems, structures and architectures, and the processes, formulae, compositions, improvements, inventions, discoveries, concepts, ideas, designs, methods and information developed, acquired, owned, produced, or practiced at any time by a party, and all non-public information relating to the business of such party.

**15. Alternate Dispute Resolution (ADR).** Any controversy, claim, or dispute ("Disputed Claim") arising out of or relating to this Agreement, except for claims relating to indemnity, infringement, or confidentiality obligations or matters relating to injunctions or other equitable relief (together "Equitable Claims"), shall be first subject to a thirty (30) day negotiation period between the parties in which each party shall disclose to the other party all such documents, facts, statements and any other information which are reasonably requested by the other party and are relevant to the dispute in question. Should such negotiations fail to resolve the dispute within thirty (30) calendar days, Disputed Claims shall be resolved by binding arbitration of a single arbitrator in accordance with the Commercial Arbitration Rules of the American Arbitration Association. The decision of the arbitrator shall be based upon this Agreement and applicable law. The decision of the arbitrator shall be reduced to writing, shall be final and binding except for fraud, misconduct, or errors of law, and judgment upon the decision rendered may be entered in any court having jurisdiction thereof. In all arbitrations, the arbitrator must give effect to applicable statutes of limitation subject to limitation of actions terms set forth in this Agreement, and shall not be afforded any authority to award relief in excess of what this Agreement provides or to order consolidation or class arbitrations. The arbitrator shall have no authority to award punitive damages in any Disputed Claim. The parties agree that any such claims arising under this Agreement must be pursued on an individual basis in accordance with the procedure noted above. Even if applicable law permits class actions or class arbitrations, the ADR procedure agreed to herein applies and the parties waive any rights to pursue any claim arising under this Agreement on a class basis. The arbitration shall be held in a mutually agreed to location, and shall be final and binding on both parties. Each party will bear its own costs of arbitration but shall split equally the fees of the arbitration and the arbitrator.

**16. Hazardous Substances.** Except as disclosed to and acknowledged in writing by Verizon, Customer certifies that it is not aware of the presence of any asbestos or other hazardous substance (as defined by any applicable state, federal or local hazardous waste or environmental law or regulation) at any location where Verizon is to perform services under this Agreement. If during such performance Verizon employees or agents encounter any such substance, Customer agrees to take all necessary steps, at its own expense, to remove or contain the asbestos or other hazardous substance and to test the premises to ensure that exposure does not exceed the lowest exposure limit for the protection of workers. Verizon may suspend performance under this Agreement until the removal or containment has been completed and approved by the appropriate governmental agency and Verizon. Performance obligations under this Agreement shall be extended for the period of delay caused by said cleanup or removal. Customer's failure to remove or contain hazardous substances shall entitle Verizon to terminate this Agreement without further liability, in which event Customer shall permit Verizon to remove any equipment that has not been accepted, shall reimburse Verizon for expenses incurred in performing this Agreement until termination (including but not limited to expenses associated with such termination, such as removing equipment, terminating leases, demobilization, etc.), and shall complete payment for any portion of the System that has been accepted.



## System Agreement

**17. Force Majeure.** Neither party shall be liable for any delay or failure in performance under this Agreement arising out of acts or events beyond its reasonable control, including but not limited to acts of God, war, terrorist acts, fire, flood, explosion, riot, embargo, acts of the Government in its sovereign capacity, labor disputes, unavailability of equipment, software or parts from vendors, or changes requested by Customer. The affected party shall provide prompt notice to the other party and shall be excused from performance to the extent of such caused delays or failures, provided that the party so affected shall use reasonable efforts to remove such causes of such delays or failures and both parties shall proceed whenever such causes are removed or cease. If performance of either party is prevented or delayed by circumstances as described in this section for more than ninety (90) days, either party may terminate the affected service or Statement of Work. Notwithstanding the foregoing, Customer shall not be relieved of its obligation to make any payments, including any late payment charges as provided in Section 2.2, above, that are due to Verizon hereunder.

**18. Assignment.** Neither party may, without the prior written consent of the other party, assign or transfer its rights or obligations under this Agreement; consent shall not be unreasonably withheld or delayed. Notwithstanding the foregoing, Verizon may, without prior notice, assign this Agreement, in whole or in part, to any Verizon affiliate or to any successor entity upon the merger, reorganization, consolidation or sale of all or substantially all of Verizon's assets associated with the equipment or services provided pursuant to this Agreement. For purposes of this Section, "affiliate" shall mean a person or entity that directly or indirectly controls, is controlled by, or is under common control with Verizon. Any attempt to assign this Agreement in contravention of this Section shall be void and of no force and effect.

**19. Governing Law.** This Agreement shall be governed by the substantive laws of the State of Delaware, without regard to its choice of law principles.

**20. Non-Waiver/Severability.** Either party's failure to enforce any of the provisions of this Agreement or to exercise any right or option is not a waiver of any such provision, right, or option, and shall not affect the validity of this Agreement. Any waiver must be written and signed by the parties. If any provision of this Agreement or the provision of any service or equipment under the terms hereof is held to be illegal, invalid, or otherwise prohibited under applicable law or regulation in any State or jurisdiction, then this Agreement shall be construed as if not containing such provision or not requiring the provision of such invalid, illegal, or prohibited service or equipment in such State or jurisdiction.

**21. Publicity.** Except as required by law, the parties shall keep this Agreement confidential and shall not disclose this Agreement or any of its terms without the other party's written consent. Notwithstanding any contrary term in this Agreement and consistent with applicable law, Verizon may disclose the terms of this Agreement, in whole or in part, to: a) Verizon affiliates; b) Verizon or Verizon affiliate suppliers and/or subcontractors that offer (including new offer or renewal offers), provide, repair, maintain, bill, collect, or perform other functions in connection with Verizon or Verizon affiliate products or services under or in connection with this Agreement; c) successors in interest to Verizon or Verizon affiliates (by merger or otherwise); and/or d) persons to whom Verizon or Verizon affiliates may sell all or part of their respective businesses or assets. Neither party shall use any trademark, trade name, trade dress or any name, picture or logo which is commonly identified with the other party or its affiliates, or from which any association with such party or its affiliates may be inferred or implied, in any manner, including but not limited to advertising, sales promotions, press releases or otherwise, without the prior written permission of such party. Notwithstanding any contrary term in this Agreement, the parties may issue or permit issuance of a press release or other public statement concerning this Agreement, provided, however, that no such release or statement shall be published without the prior mutual consent of the parties.

**22. Notices.** All notices or other communication given or required by either party to the other under this Agreement shall be deemed to have been properly given if hand-delivered, mailed by certified mail return receipt requested, or sent by facsimile with confirmation of receipt or by overnight courier. Such notices and communications shall be deemed effective upon receipt. If to Verizon, notices should be sent to Verizon Business Services, 6415-6455 Business Center Drive, Highlands Ranch, CO 80130, Attn: Customer Service (Email: [notice@verizonbusiness.com](mailto:notice@verizonbusiness.com)) with a copy to Verizon Business Services, 22001 Loudoun County Parkway, Ashburn, VA 20147, Attn: Vice President, Legal, and if to Customer to the address specified on the cover sheet. Such address may be changed by either party by notice sent in accordance with this Section.



# System Agreement

- 23. **Limitation of Actions.** A party may bring no action or demand for arbitration arising out of this Agreement more than two (2) years after the cause of action has accrued. The parties waive the right to invoke any different limitation on the bringing of actions under state law.
- 24. **Compliance with Laws.** Each party shall comply with the provisions of all applicable federal, state, and local laws, ordinances, regulations and codes in its performance under this Agreement or any Statement of Work, including without limitation the export laws of the United States or any country in which Customer receives equipment, software or services.
- 25. **Independent Contractor Relationship; No Agency.** Each party understands and agrees that it and its personnel are not agents or employees of the other party, and that each party is an independent contractor hereunder for all purposes and at all times. Neither party has the right or authority to, and shall not, assume or create any obligation of any nature whatsoever on behalf of the other party or bind the other party in any respect whatsoever. Each party shall indemnify, hold harmless and defend the other against any liabilities, claims, losses and damages (including costs, expenses and reasonable attorneys' fees) arising out of its failure to comply with this provision and any laws, rules or regulations applicable thereto.
- 26. **Interpretation.** The Agreement shall not be construed or interpreted for or against any party hereto because that party drafted or caused that party's legal representative to draft any of its provisions.
- 27. **Headings.** The Section headings used herein are for reference and convenience only and shall not enter into the interpretation of this Agreement.
- 28. **Modifications.** This Agreement may only be amended, changed, waived or modified in a written document that is signed by both parties.
- 29. **Entire Agreement.** This Agreement, together with any Statement of Work hereunder and any Exhibit hereto, constitutes the entire agreement between the parties pertaining to the subject matter herein and supercedes all prior oral and written proposals, correspondence and memoranda with respect thereto, and no representations, warranties, agreements or covenants, express or implied, of any kind or character whatsoever with respect to such subject matter have been made by either party to the other, except as expressly set forth in this Agreement. In the event of conflicts among the terms of this Agreement, a Statement of Work and/or an Exhibit, the following order of precedence shall apply: the Exhibit, this Agreement, and the Statement of Work.

IN WITNESS WHEREOF, the parties hereto have caused this Agreement to be duly executed. Each party warrants and represents that its respective representative whose signature appears below have been and are on the date of signature duly authorized to execute this Agreement and that each party has the authority to enter into this Agreement.

Verizon Business Network Services, Inc.  
on behalf of Verizon Select Services Inc.

Customer: State of West Virginia IS&C

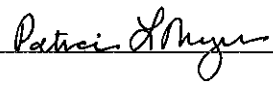
By: _____ Print Name: _____ Title: _____ Date: _____	 _____ Patricia L Myers Manager Pricing/Contract Management	By: _____ Print Name: _____ Title: _____ Date: _____	_____ _____ _____ _____
---	--	---	----------------------------------

**STATEMENT OF WORK (SOW) NO. 1-6Q6JS1  
TO VERIZON VOICE AND DATA EQUIPMENT AND  
RELATED SERVICES ATTACHMENT  
Structured Cabling Services**

<b>Customer: State of West Virginia</b>	<b>Quote: 1-6QAUP9</b>
<b>Contract ID: N/A</b>	<b>Date: 1/15/10</b>

Verizon Business Network Services Inc., on behalf of Verizon Select Services Inc.  
22001 Loudoun County Parkway  
Ashburn, VA 20147

**CUSTOMER'S LEGAL NAME:**  
State of West Virginia  
**Address**  
1900 Kanawha Blvd East  
Building 5, 10<sup>th</sup> Floor  
Charleston, WV 25305

By: Patricia L Myers  
Name: **Patricia L Myers**  
Title: **Manager**  
Date: **Pricing/Contract Management** 1/14/10

By: \_\_\_\_\_  
Name: **Krista Ferrell**  
Title: **State of WV Purchasing**  
Date: \_\_\_\_\_

This Statement of Work ("SOW") amends and is a part of the Voice and Data Equipment and Related Services Attachment and related Verizon master services agreement (collectively "Agreement"), entered between Verizon Select Services Inc. ("Verizon"), and State of West Virginia ("Customer"), Contract ID number as shown above, if applicable, executed by both parties as of January 15, 2011.

**Description of Project**

**1. Services.**

This SOW defines the structured cabling services and deliverables that Verizon will provide to Customer under the terms of the Agreement ("Structured Cabling Services") and forms the basis for the pricing in the quote referenced above (the "Quote"). Verizon will perform the Structured Cabling Services at the locations listed in the Quote. Certain Structured Cabling Services detail may be provided for Customer's reference in additional documentation separate from this Agreement.

**2. Scope of Work.**

Verizon proposes the following installation services for the State of West Virginia, Office of Technology, Disaster Recovery Center. Verizon has based the Quote on the solution and technical specifications on the customer provided RFQ# ISCL0048 Specifications and Addendum(s). The solution includes the Structured Cabling, UPS Installation.

The "System", as used within this SOW, means the structured cabling solution provided under this SOW, e.g. CPE, including without limitation, cables and other related materials.

**3. Deliverables and Documentation (if any) to be Produced by Verizon and Verizon Obligations.**

Verizon will:



- 3.1. Provide installation which complies with standards and codes, including as applicable:
  - NFPA 70 – National Electric Code
  - ANSI/TIA-568-C.0 – Generic Telecommunications Cabling for Customer Premises
  - ANSI/TIA-568-C.1 – Commercial Building Telecommunications Cabling Standard
  - TIA-569-B – Commercial Building Standard for Telecommunications Pathways and Spaces
  - ANSI/TIA-606-A – Administration Standard for Commercial Telecommunications Infrastructure
  - ANSI-J-STD-607-A – Commercial Building Grounding (Earthing) and Bonding Requirements for Telecommunications
  - TIA-526-7 – Measurement of Optical Power Loss of Installed Single-Mode Fiber Cable Plant
  - TIA-526-14-A – Optical Power Loss Measurements of Installed Multimode Fiber Cable Plant
  - ANSI/TIA-758-A – Customer-Owned Outside Plant Telecommunications Infrastructure Standard
  - ANSI/TIA-942 – Telecommunications Infrastructure Standard for Data Centers
- 3.2. Provide a single point of contact ("SPOC") who will be responsible and authorized to (i) make all decisions and give all approvals which Customer may need from Verizon, and (ii) provide Customer's personnel on a timely basis with all information, data, and support reasonably required for its performance under this SOW, including but not limited to making available appropriate personnel to work with the Customer as the Customer may reasonably request. (iii) manage and participate in the kickoff discussion, schedule coordination, and acceptance testing.
- 3.3. Deliver the System to the Customer's site(s) shown on the Quote;
- 3.4. Contact the Customer prior to install in order to confirm site readiness;
- 3.5. Provide the labor to complete the project in a good and workmanlike manner ;
- 3.6. Provide progress updates to review actual progress with the Customer SPOC;
- 3.7. Provide a schedule indicating general project deadlines with specific dates relating to the installation of the System;
- 3.8. Coordinate access to the building, daily parking, access to materials, and material storage with the Customer SPOC;
- 3.9. Additional Verizon Deliverables and Documentation:  
**The installed will be documented and delivered to the customer in the form of an As-built Drawing.**

**4. Documentation to be Produced by Customer and Customer Obligations.**

Customer must:

- 4.1 Designate a SPOC who will be responsible and authorized to (i) make all decisions and give all approvals which Verizon may need from Customer, and (ii) provide Verizon's personnel on a timely basis with all information, data, access and support reasonably required for its performance under this SOW, including but not limited to making available appropriate personnel to work with Verizon as Verizon may reasonably request.
- 4.2 Confirm and agree to the schedule indicating general project deadlines with specific dates relating to the installation of the System as provided by Verizon;
- 4.3 Provide a soft copy of all related plans clearly depicting installation locations and features that is sufficiently recent, accurate, and detailed to allow Verizon to install the System;
- 4.4 Provide the appropriate security clearances, access badges, and access to buildings and any other structures related to the Project ("Locations") and Training as defined below, if required.. It is the Customer's sole responsibility to provide the necessary means of access to Locations;
- 4.5 Provide prompt physical and electronic access to Locations where Verizon will install the System. NOTE: Wait time in excess of 60 minutes may result in a time and material charge. Verizon will coordinate Project activities in advance in order to allow for timely access and avoid delay.
- 4.6 Remove or move any obstacles required to implement this Project at a Location in a timely manner.
- 4.7 Provide loading dock space and freight elevators at no expense to Verizon. Verizon deliveries shall be scheduled during Office Hours as defined below;
- 4.8 Control all activities associated with the existing Customer equipment, including without limitation changes, additions or deletions of devices made by any non-Verizon provided technicians.
- 4.9 Provide adequate and secure storage space for the Verizon equipment, tools, and materials at the Location;

- 4.10 Unless otherwise provided for in Section 2, Scope of Work, provide sufficient rack space or other appropriate installation location for the System;
- 4.11 Ensure that the Customer's ground meets the recommendations of the System manufacturer. If a new ground work is required, Verizon can perform such work at Customer's request pursuant to a quote;
- 4.12 Ensure that any and all main or intermediate distribution frames ("MDF/IDF") are of sufficient size to accommodate System being installed;
- 4.13 Ensure conformance with any applicable codes, regulations, and laws, including but not limited to electrical, building, safety, and health;
- 4.15 Dispose of all decommissioned equipment, unless provided otherwise in the Quote.
  - If this box is checked, Verizon will demolish and dispose of all abandoned cable as required by code. If this box is not checked, Verizon will not demolish and dispose of abandoned cable.
- 4.16 Additional Responsibilities:  
 Customer is to provide prompt access to the facilities as required completing the installation(s).

**5. Change Order Request**

Customer may request changes in, or additions to, the Structured Cabling Services being provided hereunder by agreeing to a completing Verizon Change Order form, provided by Verizon. Requested changes will be facilitated to the extent feasible. If Verizon determines that such changes will cause an increase or decrease in the cost of, or time required for performance of the Structured Cabling Services, Verizon will advise Customer thereof and such adjustments will be reflected in the Verizon Change Order form. The Verizon Change Order form will not become effective unless and until it is agreed to and executed by both Customer and Verizon. Verizon will initiate changes to the project that affect cost or significantly affect schedule using this Change Order procedure.

**6. Acceptance Testing Criteria for the Service or Deliverable(s).**

Customer will have five business days after the In-Service Date, as defined below, to test the System (the "Test Period"). Customer may indicate their approval of the System by its signature on the Verizon-provided acceptance document or other mutually agreed upon means. Customer will document any issues with the System in writing to Verizon and provide those issues to Verizon within the Test Period. Upon receipt of the issues list, Verizon will have ten business days to respond and remediate any issues, as required. Customer's use of the System for any other purpose than testing will be deemed to constitute acceptance by Customer. The System will be deemed accepted if the Test Period passes without notification of issue or acceptance by Customer.

**7. Conditions.**

- 7.1 Structured Cabling Services are generally available within the 48 contiguous United States. Orders for Structured Cabling Services in Alaska and Hawaii must be specifically pre-approved by Verizon.
- 7.2 Structured Cabling Services are performed between the hours of 8:00 a.m. and 5:00 p.m. local time, Monday through Friday, excluding Verizon observed and United States Federal holidays ("Office Hours"). Work extending beyond Office Hours on Monday through Friday and work on Saturday is "Overtime" work. All other periods of work is "Sunday and Holiday Hours" work. If Customer requests that Structured Cabling Services be performed during Overtime or Sunday and Holiday Hours, Customer will pay Verizon its then current time and material labor rate.
  - If this box is checked, this project requires work to be performed outside of Office Hours. The Structured Cabling Services will be performed between the hours of \_\_\_\_\_ of \_\_\_\_\_ of \_\_\_\_\_. These hours are included in the Quote.
- 7.3 Unless Customer otherwise requests in writing Verizon will, at Customer's expense, apply for permits necessary for Structured Cabling Services.
- 7.4 Verizon will provide Customer written notice indicating the date Structured Cabling Services is complete (the "In-Service Date"). Verizon will attempt to meet Customer's requested In-Service Dates, however Verizon can not guarantee any In-Service Date. In-Service Dates are subject to the availability of materials and resources.
- 7.5 Should Customer request delay of Structured Cabling Services, or should Structured Cabling Services be delayed as a result of Customer's action or inaction, Verizon may store the System, or any portion thereof, at Customer's risk and expense.

- 7.7 Verizon will use reasonable efforts to avoid interruption of Customer's network service during Office Hours. If it is necessary to interrupt network service during Office Hours, Verizon will notify the SPOC at least 48 hours in advance.
- 7.8 Customer will only assign persons to this project that have the necessary skills required to complete the Customer's part of this project.
- 7.9 Customer will allow Verizon access to sites for performance of any required Structured Cabling Service. Customer will notify Verizon of any site-specific requirements that might impact Verizon's ability to access such site, e.g. safety or security training ("Training"). Verizon will comply with such Training requirements however Verizon reserves the right to bill Customer for the time required for Training at Verizon's then current labor rate. Customer will provide necessary badges, escorts, etc. required for site access per Customer's security and safety policies.

If this box is checked, Verizon personnel will require additional training for site access.

7.10 Additional Conditions

**Customer is to provide prompt access to the facilities as required completing the installation(s).**

8. **Term of SOW.** This SOW is effective upon full execution by the parties and will remain in effect during the delivery of the Structured Cabling Services. Except for warranties specifically provided herein, this SOW will terminate upon final delivery of the Structured Cabling Services.

9. **Warranty**

- 9.1 Verizon warrants the System against defects solely related to Verizon's installation for one year after the System is accepted as provided above. To the extent permitted, manufacturers' end user warranties will be passed through to Customer. Customer will present such warranty claims directly to the manufacturer.
- 9.2 If a manufacturer's end-user warranty is included, Verizon will provide the appropriate certified labor, documentation, and materials to qualify the installation for such warranty.
- If this box is checked, the System includes manufacturer's warranty.
- 9.3 These warranties do not cover damage to or malfunction of the System caused in whole or in part by Customer or third parties through other than normal use of the System or caused by an event external to the System. The warranties contained herein are Customer's sole and exclusive warranties for Structured Cabling Services.

10. **Assumptions**

- 10.1 This SOW constitutes the entire agreement between the parties with respect to the Structured Cabling Services and supersedes all other prior or contemporaneous representations, understandings or agreements. Except as otherwise expressly stated herein, no amendment to this SOW is valid unless in writing and signed by both parties.
- 10.2 Structured Cabling Services are limited to the services, deliverables, documentation, and conditions stated herein and in the Agreement, and the System defined in the Quote.
- 10.3 Additional Assumptions  
N/A



State of West Virginia  
 Department of Administration  
 Purchasing Division  
 2019 Washington Street East  
 Post Office Box 50130  
 Charleston, WV 25305-0130

# Request for Quotation

RFQ NUMBER  
 ISCL0048

PAGE  
 1

ADDRESS CORRESPONDENCE TO ATTENTION OF  
 KRISTA FERRELL  
 304-558-2596

PROPERTY

RFQ COPY  
 TYPE NAME/ADDRESS HERE

Verizon Select Services Inc.  
 4700 MacCorkle Avenue, SE  
 Charleston, WV 25304

PROPERTY

DEPARTMENT OF ADMINISTRATION  
 IS&C - COMMUNICATIONS  
 1900 KANAWHA BLVD. E.  
 BUILDING 5, 10TH FLOOR  
 CHARLESTON, WV  
 25305 304-558-5472

DATE PRINTED	TERMS OF SALE	SHIP VIA	FOB	FREIGHT TERMS
12/22/2010				
BID OPENING DATE: 01/20/2011		BID OPENING TIME 01:30PM		

LINE	QUANTITY	UOP	QAT NO	ITEM NUMBER	UNIT PRICE	AMOUNT
ADDENDUM NO. 1						
THIS ADDENDUM IS ISSUED TO:						
1.) ADD A MANDATORY PRE-BID MEETING PER THE ATTACHED						
2.) EXTEND THE DEADLINE FOR TECHNICAL QUESTIONS FROM DECEMBER 22, 2010 TO JANUARY 10, 2010 AT THE CLOSE OF BUSINESS.						
3.) EXTEND THE BID OPENING DATE FROM JANUARY 12, 2011 TO JANUARY 20, 2011 AT 1:30 PM.						
***** NO OTHER CHANGES *****						
0001	1	EA		287-54		
THREE PHASE UNINTERRUPTIBLE POWER SUPPLY						

SEE REVERSE SIDE FOR TERMS AND CONDITIONS

SIGNATURE: *Patricia L Myers* TELEPHONE: 3043563395 DATE: 1/11/11  
 TITLE: Patricia L Myers, Manager, Pricing/Contract Management  
 FEIN: 16-1337624 ADDRESS CHANGES TO BE NOTED ABOVE

TO RFQ, INSERT NAME AND ADDRESS IN SPACE ABOVE LABELED 'VENDOR'

**GENERAL TERMS & CONDITIONS**  
**REQUEST FOR QUOTATION (RFQ) AND REQUEST FOR PROPOSAL (RFP)**

1. Awards will be made in the best interest of the State of West Virginia.
  2. The State may accept or reject in part, or in whole, any bid.
  3. Prior to any award, the apparent successful vendor must be properly registered with the Purchasing Division and have paid the required \$125 fee.
  4. All services performed or goods delivered under State Purchase Order/Contracts are to be continued for the term of the Purchase Order/Contracts, contingent upon funds being appropriated by the Legislature or otherwise being made available. In the event funds are not appropriated or otherwise available for these services or goods this Purchase Order/Contract becomes void and of no effect after June 30.
  5. Payment may only be made after the delivery and acceptance of goods or services.
  6. Interest may be paid for late payment in accordance with the *West Virginia Code*.
  7. Vendor preference will be granted upon written request in accordance with the *West Virginia Code*.
  8. The State of West Virginia is exempt from federal and state taxes and will not pay or reimburse such taxes.
  9. The Director of Purchasing may cancel any Purchase Order/Contract upon 30 days written notice to the seller.
  10. The laws of the State of West Virginia and the *Legislative Rules* of the Purchasing Division shall govern the purchasing process.
  11. Any reference to automatic renewal is hereby deleted. The Contract may be renewed only upon mutual written agreement of the parties.
  12. **BANKRUPTCY:** In the event the vendor/contractor files for bankruptcy protection, the State may deem this contract null and void, and terminate such contract without further order.
  13. **HIPAA BUSINESS ASSOCIATE ADDENDUM:** The West Virginia State Government HIPAA Business Associate Addendum (BAA), approved by the Attorney General, is available online at [www.state.wv.us/admin/purchase/vrc/hipaa.htm](http://www.state.wv.us/admin/purchase/vrc/hipaa.htm) and is hereby made part of the agreement. Provided that the Agency meets the definition of a Cover Entity (45 CFR §160.103) and will be disclosing Protected Health Information (45 CFR §160.103) to the vendor.
  14. **CONFIDENTIALITY:** The vendor agrees that he or she will not disclose to anyone, directly or indirectly, any such personally identifiable information or other confidential information gained from the agency, unless the individual who is the subject of the information consents to the disclosure in writing or the disclosure is made pursuant to the agency's policies, procedures, and rules. Vendor further agrees to comply with the Confidentiality Policies and Information Security Accountability Requirements, set forth in <http://www.state.wv.us/admin/purchase/privacy/noticeConfidentiality.pdf>.
  15. **LICENSING:** Vendors must be licensed and in good standing in accordance with any and all state and local laws and requirements by any state or local agency of West Virginia, including, but not limited to, the West Virginia Secretary of State's Office, the West Virginia Tax Department, and the West Virginia Insurance Commission. The vendor must provide all necessary releases to obtain information to enable the director or spending unit to verify that the vendor is licensed and in good standing with the above entities.
  16. **ANTITRUST:** In submitting a bid to any agency for the State of West Virginia, the bidder offers and agrees that if the bid is accepted the bidder will convey, sell, assign or transfer to the State of West Virginia all rights, title and interest in and to all causes of action it may now or hereafter acquire under the antitrust laws of the United States and the State of West Virginia for price fixing and/or unreasonable restraints of trade relating to the particular commodities or services purchased or acquired by the State of West Virginia. Such assignment shall be made and become effective at the time the purchasing agency tenders the initial payment to the bidder.
- I certify that this bid is made without prior understanding, agreement, or connection with any corporation, firm, limited liability company, partnership, or person or entity submitting a bid for the same material, supplies, equipment or services and is in all respects fair and without collusion or fraud. I further certify that I am authorized to sign the certification on behalf of the bidder or this bid.

**INSTRUCTIONS TO BIDDERS**

1. Use the quotation forms provided by the Purchasing Division. Complete all sections of the quotation form.
2. Items offered must be in compliance with the specifications. Any deviation from the specifications must be clearly indicated by the bidder. Alternates offered by the bidder as **EQUAL** to the specifications must be clearly defined. A bidder offering an alternate should attach complete specifications and literature to the bid. The Purchasing Division may waive minor deviations to specifications.
3. Unit prices shall prevail in case of discrepancy. All quotations are considered F.O.B. destination unless alternate shipping terms are clearly identified in the quotation.
4. All quotations must be delivered by the bidder to the office listed below prior to the date and time of the bid opening. Failure of the bidder to deliver the quotations on time will result in bid disqualifications: Department of Administration, Purchasing Division, 2019 Washington Street East, P.O. Box 50130, Charleston, WV 25305-0130
5. Communication during the solicitation, bid, evaluation or award periods, except through the Purchasing Division, is strictly prohibited (W.Va. C.S.R. §148-1-6.6).

To add the following language:

A mandatory pre-bid meeting will be held on Wednesday, January 5, 2011 at 11:00 am at the agency's location at the Disaster Recovery Center located at 89 Richard D. Munnich Drive in Sutton, WV. Interested parties are required to attend this meeting. Failure to attend the mandatory pre-bid shall result in the disqualification of the bid. No one person may represent more than one bidder.

An attendance sheet will be made available for all potential bidders to complete. This will serve as the official document verifying attendance at the mandatory pre-bid. Failure to provide your company and representative name on the attendance sheet will result in disqualification of the bid. The State will not accept any other documentation to verify attendance. The bidder is responsible for ensuring they have completed the information required on the attendance sheet. The Purchasing Division and the State agency will not assume any responsibility for a bidder's failure to complete the pre-bid attendance sheet. In addition, we request that all potential bidders include their e-mail address and fax number.

All potential bidders are requested to arrive prior to the starting time for the pre-bid. Bidders who arrive late, but prior to the dismissal of the technical portion of the pre-bid will be permitted to sign in. Bidders who arrive after the conclusion of the technical portion of the pre-bid will not be permitted to sign the attendance sheet.



State of West Virginia  
 Department of Administration  
 Purchasing Division  
 2019 Washington Street East  
 Post Office Box 50130  
 Charleston, WV 25305-0130

# Request for Quotation

RFQ NUMBER  
 ISCL0048

PAGE  
 1

ADDRESS CORRESPONDENCE TO ATTENTION OF  
 KRISTA FERRELL  
 304-558-2596

RFQ COPY  
 TYPE NAME/ADDRESS HERE

Verizon Select Services Inc.  
 4700 MacCorkle Avenue, SE  
 Charleston, WV 25304

DEPARTMENT OF ADMINISTRATION  
 IS&C - COMMUNICATIONS  
 1900 KANAWHA BLVD. E.  
 BUILDING 5, 10TH FLOOR  
 CHARLESTON, WV 25305  
 304-558-5472

DATE PRINTED	TERMS OF SALE	SHIP VIA	F.O.B.	FREIGHT TERMS
01/10/2011				

BID OPENING DATE: 01/20/2011 BID OPENING TIME 01:30PM

LINE	QUANTITY	UOP	CAT. NO.	ITEM NUMBER	UNIT PRICE	AMOUNT
				ADDENDUM NO. 2		
				THIS ADDENDUM IS ISSUED TO:		
				1.) PROVIDE A COPY OF THE MANDATORY PRE-BID ATTENDEE LIST,		
				2.) PROVIDE CLARIFICATION AS STATED BELOW,		
				"THE ISOLATION TRANSFORMER MUST BE SUPPLIED BY THE VENDOR AS STATE IN THE PRE-BID CONFERENCE ON 01/05/2011."		
				3.) PROVIDE ANSWERS TO ALL TECHNICAL QUESTIONS SUBMITTED IN ACCORDANCE WITH THE PROVISIONS OF THE ORIGINAL REQUEST FOR QUOTATION, ISCL0048.		
				BID OPENING DATE REMAINS: 01/20/2011		
				BID OPENING TIME REMAINS: 1:30 PM		
				***** END ADDENDUM NO. 2 *****		
0001	1	EA		287-54		
				THREE PHASE UNINTERRUPTIBLE POWER SUPPLY		

SEE REVERSE SIDE FOR TERMS AND CONDITIONS

SIGNATURE <i>Patricia L Myers</i>	TELEPHONE 304 356 3395	DATE 1/11/11
TITLE Patricia L Myers Manager Pricing/Contract Management	FEIN 16-133 7624	ADDRESS CHANGES TO BE NOTED ABOVE

FOR BIDDING TO RFQ, INSERT NAME AND ADDRESS IN SPACE ABOVE LABELED 'VENDOR'

PRE-BID CONFERENCE  
SIGN IN SHEET

Request for Quotation Number: 1501-0049

Date: January 5, 2011

Project Description: Three Phase Uninterruptible Power Supply

PLEASE PRINT LEGIBLY. THIS INFORMATION IS ESSENTIAL TO CONTACT THE ATTENDEES IN A TIMELY MANNER. FAILURE TO DO SO MAY RESULT IN DELAYS IN YOUR COMPANY SEEING IMPORTANT BID INFORMATION.

Firm Name:	<u>VACO INC</u>
Firm Address:	<u>127 Fairwood Rd Clark, VA P.O. Box 1000, Clark, VA 22031</u>
Representative Attending:	<u>Lawrence Hess</u>
Phone Number:	<u>301-281-2323</u>
Fax Number:	<u>301-281-0505</u>
Email Address:	<u>lawrence.hess@vaco.com</u>

Firm Name:	<u>SYSTEM ENGINEERING (INTERNATIONAL)</u>
Firm Address:	<u>515 Burgess Ct Farmingdale, NY 11737</u>
Representative Attending:	<u>Christina Davis</u>
Phone Number:	<u>516-271-7601</u>
Fax Number:	<u>516-271-7602</u>
Email Address:	<u>christina@seintl.com</u>

Firm Name:	<u>Hickman &amp; Leitch Corp</u>
Firm Address:	<u>701 J. Paul St Suffolk, VA 23401</u>
Representative Attending:	<u>Bradley F. Hickman</u>
Phone Number:	<u>804-264-5116</u>
Fax Number:	<u>804-264-5116</u>
Email Address:	<u>bradley@hickmanleitch.com</u>

Firm Name:	<u>ASPE SERVICE AND SUPPLY</u>
Firm Address:	<u>1000 E. 2nd St Suffolk, VA 23401</u>
Representative Attending:	<u>Pat Smith</u>
Phone Number:	<u>804-634-3170</u>
Fax Number:	<u>804-636-4200</u>
Email Address:	<u>pat@aspe.com</u>

Firm Name:	<u>ADVIZEL TECHNOLOGIES</u>
Firm Address:	<u>116 S. Salsler Rd Suffolk, VA Colonial Park</u>
Representative Attending:	<u>M. Keith Ream</u>
Phone Number:	<u>804-864-8888</u>
Fax Number:	<u>804-864-8887</u>
Email Address:	<u>m.ream@advizel.com</u>

Firm Name:	<u>ALSON &amp; BROWN</u>
Firm Address:	<u>101 Salsler Drive Suffolk, VA 23401</u>
Representative Attending:	<u>Greg Bondack</u>
Phone Number:	<u>804-561-8703</u>
Fax Number:	<u>804-755-4010</u>
Email Address:	



PRE-BID CONFERENCE  
SIGN IN SHEET

Request for Quotation Number:

ISCL0048

Date:

January 5, 2011

Project Description:

Three Phase Water Treatment Power Supply

PLEASE PRINT LEGIBLY. THIS INFORMATION IS ESSENTIAL TO CONTACT THE ATTENDEES IN A TIMELY MANNER. FAILURE TO DO SO MAY RESULT IN DELAYS IN YOUR COMPANY GETTING IMPORTANT BID INFORMATION.

Firm Name:	Kessler Electric
Firm Address:	2315 William Ave Pgh PA 15285
Representative Attending:	Chris Kessler
Phone Number:	412-334-2201
Fax Number:	
Email Address:	Chris.Kessler@kessler.com

Firm Name:	1504 195 JAMES ST. CHARLESTON WV
Representative Attending:	NICHOLAS TEMPLE
Phone Number:	PIKE PARKER 304 784 7664
Fax Number:	
Email Address:	PRIMER@DSTON.COM

Firm Name:	ESSEX Checkmate Elec
Firm Address:	1416 17th Street So. Charleston WV
Representative Attending:	Danny Wagoner
Phone Number:	781-6263
Fax Number:	
Email Address:	

Firm Name:	DREBE of Jackson
Firm Address:	Capitol Park West Charleston WV
Representative Attending:	
Phone Number:	304 957-7102
Fax Number:	
Email Address:	Ann.K.Hopfer@GOU.CO.V

Firm Name:	City Electric Company
Firm Address:	1212 Pennsylvanias Ave Charleston WV 25302
Representative Attending:	Chris W. Hock
Phone Number:	304-343-6152
Fax Number:	304-343-6152
Email Address:	Chris.Hock@cityelec.com

Firm Name:	ANDY
Firm Address:	Smith Co Charleston WV 25302
Representative Attending:	Brian Poff
Phone Number:	304-957-5085
Fax Number:	304-558-1414
Email Address:	Brian.S.Poff@GOU.CO.V

PRE-BID CONFERENCE  
SIGN IN SHEET

Request for Quotation Number: 15CLO0048 Date: January 5 2011

Project Description: Three Phase Transformer Capable Power Supply

PLEASE PRINT LEGIBLY. THIS INFORMATION IS ESSENTIAL TO CONTACT THE ATTENDEES IN A TIMELY MANNER. FAILURE TO DO SO MAY RESULT IN DELAYS IN YOUR COMPANY GETTING IMPORTANT BID INFORMATION.

Firm Name: Frank Lorch  
 Firm Address: 2014 2nd St  
Charleston, WV 25301  
 Representative Attending: Frank Lorch  
 Phone Number: 304-248-1110  
 Fax Number: 304-248-1116  
 Email Address: FLORCH@FRANKLORENZ.COM

Firm Name: Office of Technology / OSA  
 Firm Address: Bldg. 5 10th Floor  
Charleston  
 Representative Attending: Rob Norwood  
 Phone Number: 304-257-9157  
 Fax Number:   
 Email Address: Robert.A.Norwood@wv.gov

Firm Name: Onside Electric  
 Firm Address: 2014 2nd St  
Charleston, WV  
 Representative Attending: Frank Lorch  
 Phone Number: 304-248-1110  
 Fax Number: 304-248-1116  
 Email Address: FLORCH@FRANKLORENZ.COM

Firm Name: WV DI  
 Firm Address: Bldg. 5 10th Floor  
Charleston, WV 25305  
 Representative Attending: Linda Harper  
 Phone Number: 304-257-6837  
 Fax Number:   
 Email Address: Linda.B.Harper@wv.gov

Firm Name: AUSTIN POWER LINE  
 Firm Address: P.O. Box 2041  
S. CHARLESTON WV  
25303  
 Representative Attending: LEONARD VANDER  
 Phone Number: 304-546-1171  
 Fax Number: 304-546-2745  
 Email Address: LEONARD.VANDER@APLWS.COM

Firm Name:   
 Firm Address:   
 Representative Attending:   
 Phone Number:   
 Fax Number:   
 Email Address:

**ADDENDUM # 2,  
TECHNICAL QUESTIONS AND ANSWERS  
RFQ#: ISCL0048**

- Q1. Does the state have standard dock facilities and equipment to off load heavy pallets from a large truck or will inside delivery be required?
- A. NO, truck with its own lift is necessary.
- Q2. If inside delivery is required, please provide detailed information regarding any obstacles that will need to be negotiated, such as stairs or narrow doorways less than 36" wide. If inside delivery is required, please provide the approximate distance from where the requested equipment will be off loaded and the final delivery location. Please elaborate about any possible difficulties in moving the equipment inside the building.
- A. No stairs. On first floor, approximately 150 Feet from off load to final delivery.
- Q3. This RFQ request installation of one new Liebert Uninterruptible Power Supply. If installation of this equipment by a licensed electrician is required, I will need to schedule a site visit to determine length of run of wire, conduit and obtain other logistic parameters. Can you provide me with this site contact name and phone number so I can schedule this visit?
- A. Pre-bid conference 01/05/2011.
- Q4. If site visit is not possible, can you provide me with an approximate distance between the governments input electrical panel that will feed the new UPS and the location where this UPS will be installed. Also, I need an approximate distance between the output distribution panel and the location where the new UPS will be installed.
- A. Pre-bid conference 01/05/2011.

- Q5. What is ability to offload this ups and equipment? (Tractor high loading dock street level, etc.)
- A. No loading dock.
- Q6. Able to take equipment to final location using elevators? Pallet jack available?
- A. No elevator needed. No pallet jack available. On first floor, approximately 150 Feet from off load to final delivery.
- Q7. Existing wiring sufficient for new equipment?
- A. Can be seen at pre-bid conference 01/05/2011.
- Q8. Is there an existing ups unit to remove? Disposal needed?
- A. No existing equipment installed at this location, everything will need to be installed new.
- Q9. Ship to address on RFQ not same as install site at Sutton. What is delivery location? Delivery location will be
- A. BRAXTON TECHNOLOGY CENTER, 89 Richard D. Minnich Dr., Sutton WV 26601.
- Q10. A site visit would be very desirable.
- A. Site visit 01/05/2011.
- Q11. Are there building drawings available? If not:
- A. Brochure attached with pictures of the building and 2<sup>nd</sup> floor plan, not to scale.
- Q12. What is the existing doorframe sizing?
- A. Standard 6'X6' 8" doors.

Q13. How new/old is the building?

A. Constructed 2006.

Q14. General construction; walls, ceilings, etc.?

A. In what location of the building.

Q15. What floor is the "data center" on?

A. First floor.

Q16. What floor is the service entrance and/or the power for this new UPS on?

A. In the same room.

Q17. How far from the power to the UPS?

A. Around 10 feet.

Q18. Is the available power 480v or 208v?

A. 208v.

Q19. Is there a loading dock?

A. No.

Q20. Is the data center on the same level as the loading dock?

A. There is no loading dock.

Q21. If not; is there an adequate elevator to get the UPS to the floor of the data center?

A. The Data Center is on the first floor, ground level.

Q22. Does the DC have ramp access?

A. See above questions.

Q23. Will we need to protect existing floors during delivery?

A. Any damage to the building caused by the contractor installing this UPS will be responsible for repairs.

Q24. Will rigging be required?

A. That is up to the Contractor.

Q25. Can WV provide a one-line of the existing/proposed system?

A. Do not understand this question.

Q26. Are we replacing an existing UPS system or is this an additional system?

A. New Install.

Q27. If WV has an existing system for the UPS to tie into, should IBM include configuration of that system on that existing system?

A. New System, new install.

Q28. Are there existing panels/loads to refeed?

A. The Main Output Panel is already installed and must be feed.

Q29. Other than electrical panels that may need to be re-fed, are there dedicated circuits already provisioned for the UPS and if so, what age?

A. NO.

Q30. WV will coordinate all genset phasing and grounding issues?

A. This is part of the UPS Installation, contractor's responsibility.

Q31. Will IBM be responsible for EPO tie-in?

A. IBM has nothing to do with installation.

Q32. Will an onsite load bank be required?

A. NO.

Q33. What is WV's preference for installation? (day or weekend?)

A. Days.

Q34. Since the UPS is 80/120kva does WV plan to expand to 120kva?

A. Maybe at a later date.

**AVAILABLE SPACE  
BRAXTON TECHNOLOGY CENTER**

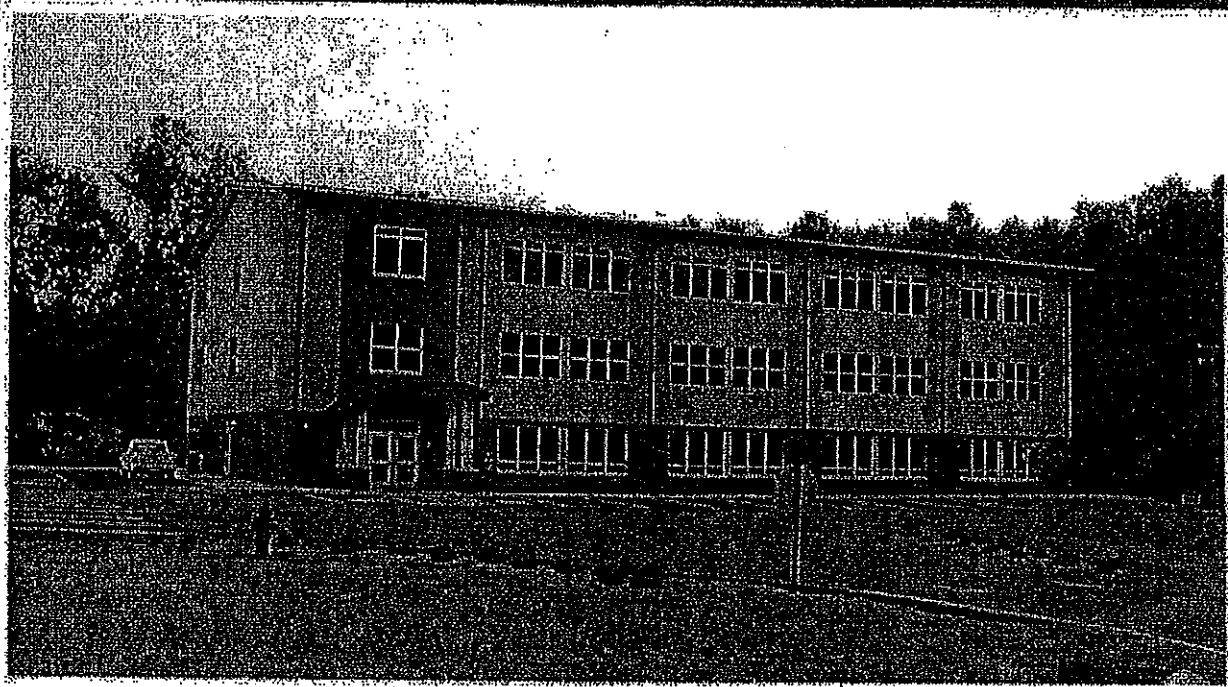

**LOCATION**

Address: 89 Richard D. Minich Drive  
Sutton, WV 26601  
Zoning: None  
County: Braxton

**SIZE**

Total Square Feet Available: 4,579  
Number of Floors: 3  
Available Square Feet per Floor: 1st Floor: 0  
2nd Floor: 4,579  
3rd Floor: 0

Will Owner Subdivide Space? Yes  
Acreage: 4

**SPECIFICATIONS**

Former Use of the Building: New Construction  
If Former Call Center, How many Work Stations: N/A  
Broadband Service Available: Verizon and Fibernet provide fiber to the building.  
Proximity to Point of Residence (POP) Adjacent to building  
Number of Parking Spaces: 61  
Redundant Power Supply: Backup generator & UPS  
Redundant Telephone Service: Yes  
Security System Installed: Yes  
Sprinkler System Installed: Yes  
Date of Construction: 2006  
Elevators: One passenger

**Handicap Accessibility:**

Restrooms: Yes  
Rampings: Yes  
HVAC System: Forced Air, Carrier Heat Pumps, Gas Furnace  
Build-Out Required: Yes, Part of 1st floor, All of 2nd & 3rd Floors  
Ceiling Height: 8' 1st Floor  
Flood Zone: None  
Annual Taxes:

**UTILITIES**

Electricity: Allegheny Power  
Gas: Dominion  
Water: Flatwoods Cartridge Run PSD  
Sewer: Flatwoods Cartridge Run PSD  
Telephone: Verizon, Fibernet, Micrologix Int.

**FOR SALE/LEASE**

Lease Rate: \$19.00/sf/Year, negotiable depending on build-out, all inclusive, except telephone service, 5 year lease  
Availability: Immediate

**FOR FURTHER INFORMATION CONTACT**

Terrell Ellis  
Braxton County Development Authority  
PO Box 486  
Sutton, WV, 26601  
Phone: (866) 852-3535 Fax: (304) 342-4639  
Email: tcellis@bcda.com



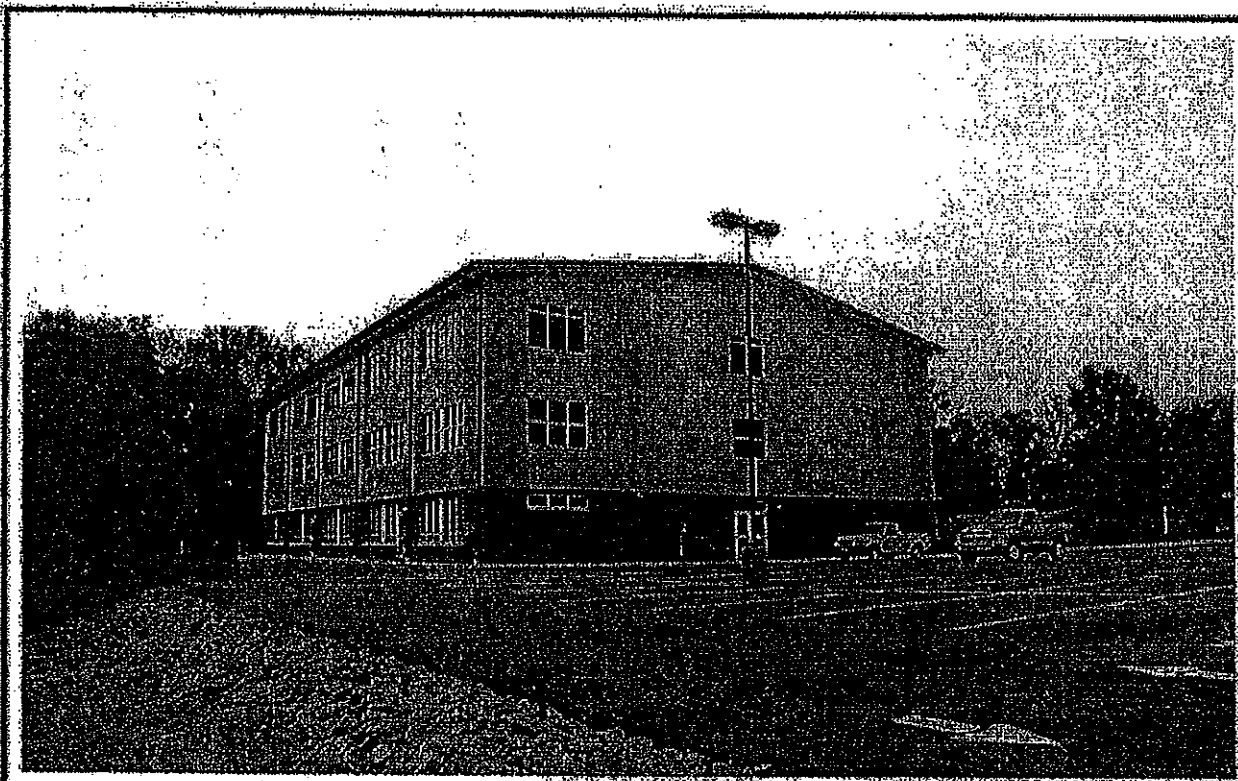

REAR OF BUILDING SHOWING PARKING LOT

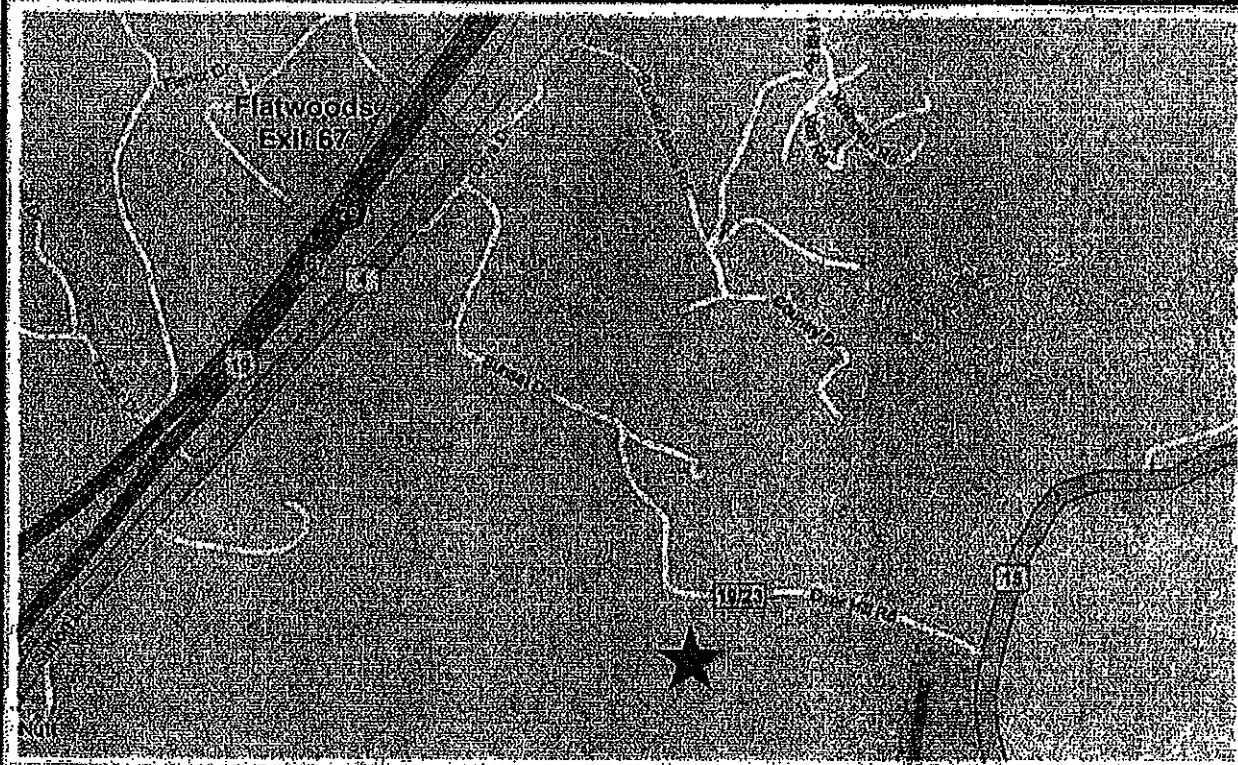

SUTTON, WEST VIRGINIA

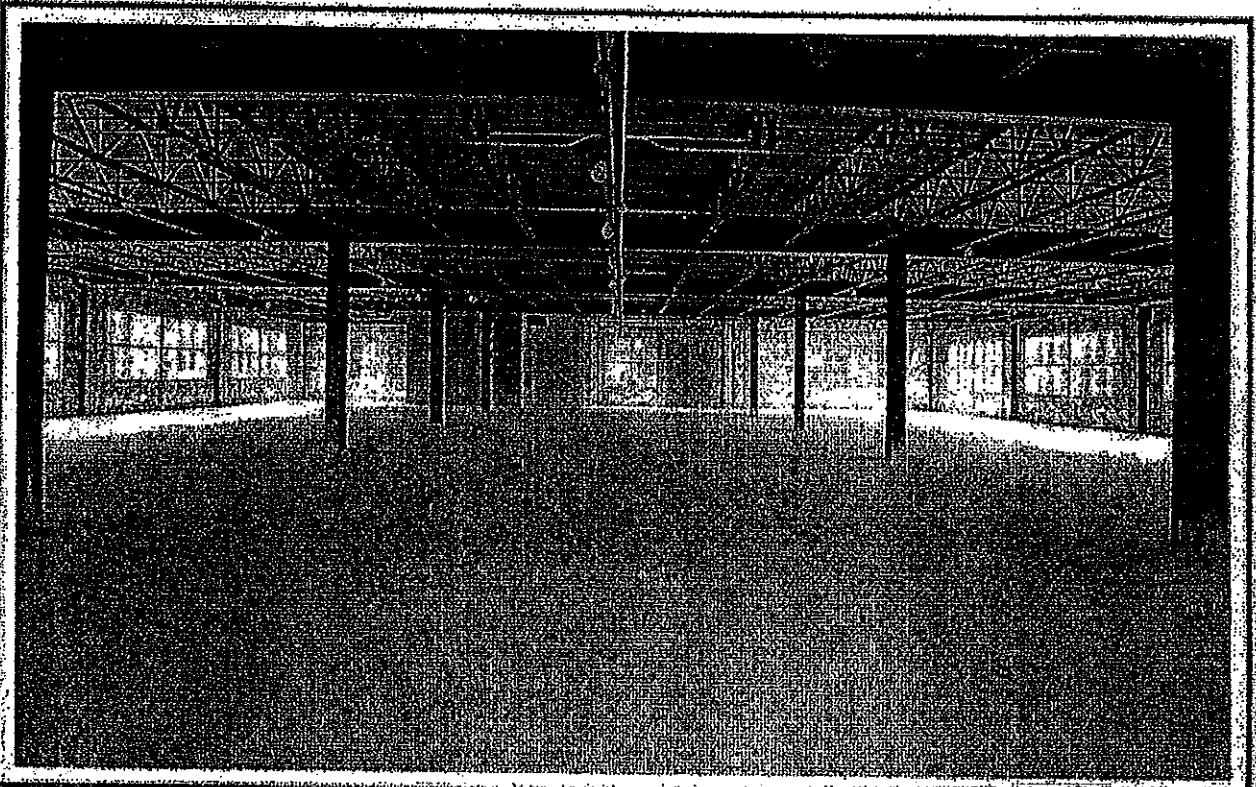

2ND FLOOR (4,579 SQ. FT. AVAILABLE)

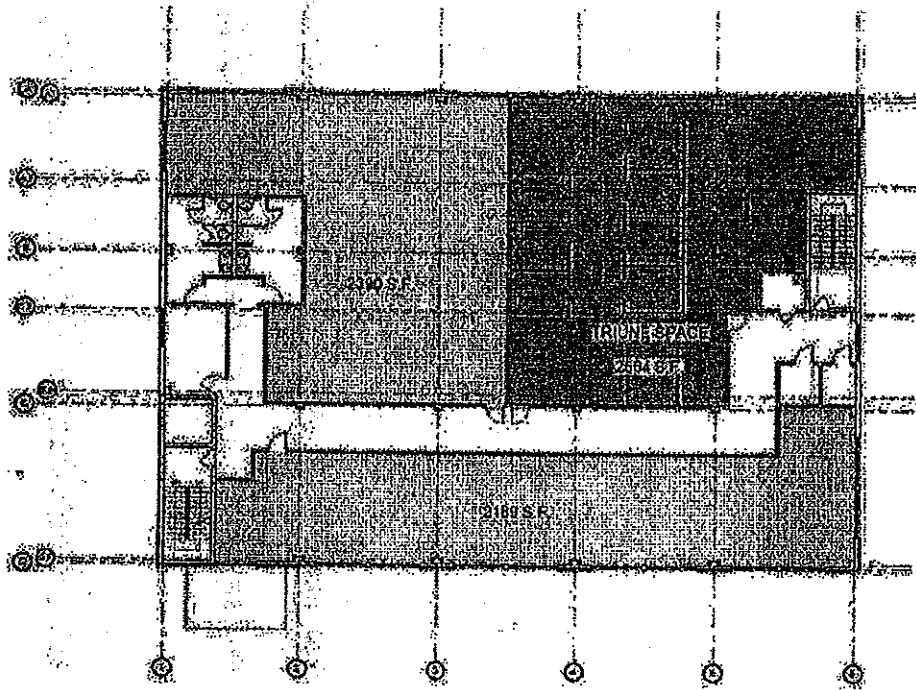

2ND FLOOR PLAN (NOT TO SCALE)

40 to 130 kVA

# MGE™ Galaxy™ 5000

*Flexible Three Phase Power Protection*

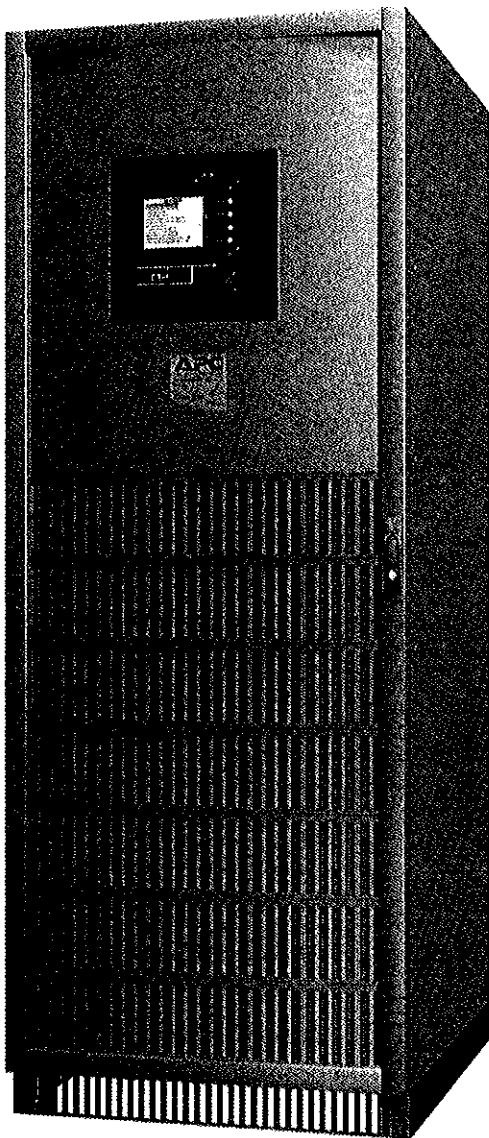

**Performance Three Phase  
Power Protection with  
Adaptability to Meet the  
Unique requirements of  
Small to Medium  
Datacenters, Buildings and  
Facilities**

- > Upgradeable power ranges
- > Internal maintenance bypass
- > Intuitive monitoring
- > Parallel Capable
- > Front access servicing

# 40 kVA to 130 kVA

## High Power Availability

The MGE Galaxy 5000 has been designed for continuous operation

- > Fault tolerance with built-in 100% rated bypass static switch
- > Redundant components for greater reliability
- > High overload capacity to improve downstream discrimination
- > Extended Battery backup times available

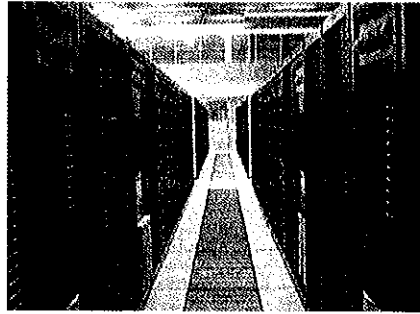

## Flexible and Upgradeable

The MGE Galaxy 5000 adapts to your changing needs

- > Expandable Power ranges
- > Parallel up to 6 modules for higher capacity or redundancy
- > Easy integration with networking and monitoring systems
- > A choice of backup times from 5 minutes to 8 hours
- > Compatible with inductive and leading power factor loads
- > Field Upgradeable from Single to Parallel

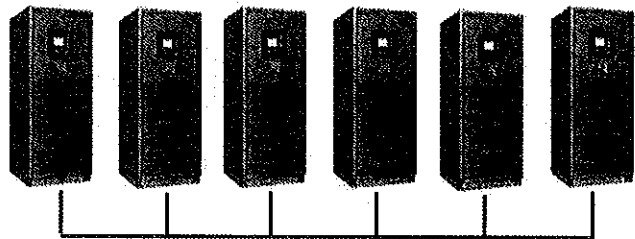

## Low total cost of ownership

The MGE Galaxy 5000 helps to minimize your infrastructure costs

- > Small footprint
- > Power factor corrected input prevents the need for oversizing cables, circuit breakers and generator
- > Efficiency in on-line double conversion mode up to 93.5%

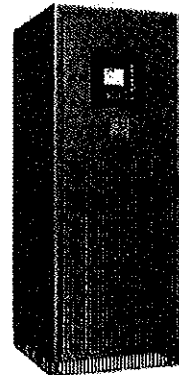

## Features that make the difference

### IGBT based technology for Power Quality

Supplies clean, stable power to sensitive loads ensuring critical power protection, optimum performance, and extended life

### Parallel Operation

Connect as many as 6 units in parallel for capacity and redundancy to grow with your power requirements

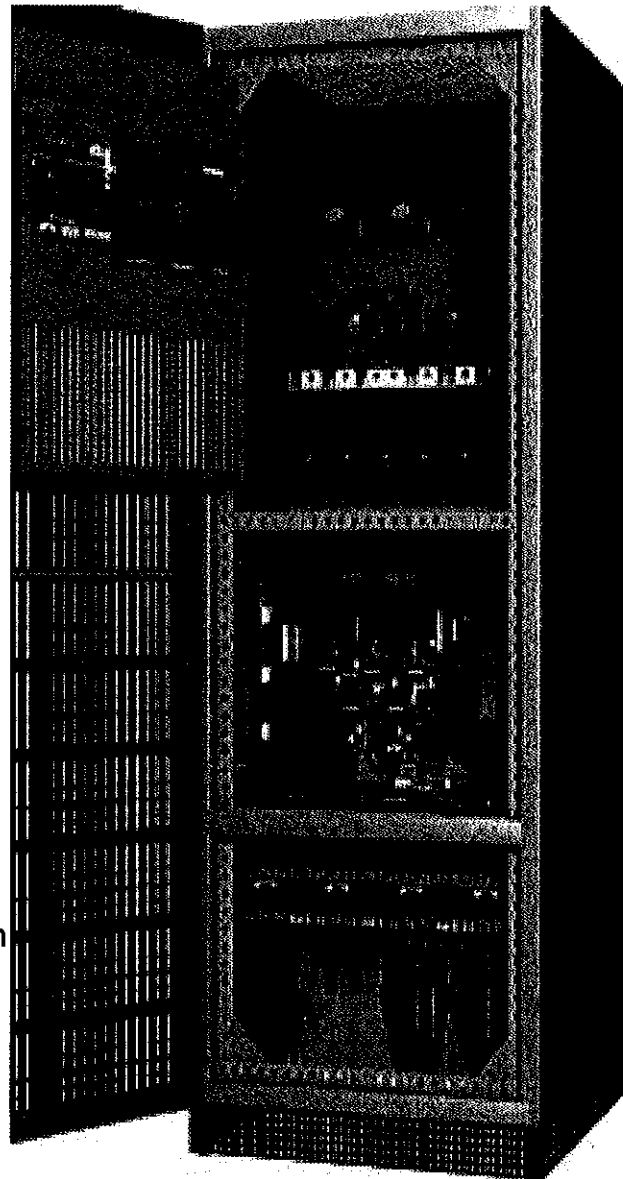

### Dual Input

Allows for connection to two separate input sources for increased availability

### Redundant components

Back up for the Main Intelligence Module provides increased availability

### Built-In Static and maintenance Bypass

Enables the UPS to transfer the load to utility power, without interruption, in the event of heavy overload or fault

### Optional Auxiliary Gear

- > Input/Output transformers
  - 208V/220V/480V/600V
- > Wall Mount Battery Disconnect
- > Matching Battery Cabinets
  - Up to four (4) enclosures can be connected to the UPS for extended run times of up to 4 hours
- > Distribution
  - Panel board
  - Sub Feed Breakers
- > Matching External Maintenance Bypass
- > Parallel System Bypass Cabinets
- > Communication cards
  - RS232 / RS485 / Dry Contact
  - Network Management Card
- > Top Entry Cabinets
- > 65kAIC rating
- > Seismic Brackets
- > Remote Alarm Panel

# Technical characteristics

Rated power ( kVA/KW )	40/36	50/45	60/54	80/72	100/90	130/117
<b>Normal AC Input</b>						
Input Voltage (V)	480V Core, 3 Wire + G (220V, 208V, 600V w/ Aux Transformer 4 Wire + G)					
Frequency	60Hz +/- 5%					
Power Factor	< 0.99					
Current Distortion (THDI)	< 5%					
<b>Bypass AC Input</b>						
Bypass Overload	10x nominal current for 1 cycle					
<b>Load Output</b>						
Output Voltage	480V Core, 3 Wire + G (220V, 208V, 600V w/ Aux Transformer 4 Wire + G)					
Frequency	60Hz					
Voltage Regulation	+/- 1.0% balance load , +/- 2.5% unbalanced load					
Voltage Transient Response	+/- 5% for 100% step load, +/-1% for loss or return of AC input					
Voltage Recovery Time	Within 1% of nominal within 1 cycle					
Voltage Distortion	<1% L-L and L-N for non-linear loads (<2% max)					
Inverter Overload	150% for 1 min, 125% for 10min					
Heat Rejection (BTU) @480V	9248	11560	13872	18496	19607	25489
<b>Overall efficiency</b>						
Double conversion mode	Up to 94%					
<b>Environmental</b>						
Storage temperature	-20C to +45C ( -4F to 113F)					
Operating temperature	UPS 0-40C (32F to 104F), Battery 25C(77F)					
Operating altitude	1000 m					
<b>Dimensions and Weights</b>						
Dimensions and weights	28" W x 33.42" D x 75" H (882 lbs)			28" W x 33.42" D x 75" H (1146 lbs)		
Matching Maintenance Bypass	28" W x 33.42" D x 75" H					
Transformer Cabinet	28" W x 33.42" D x 75" H					
Distribution Cabinet	42" W x 33.42" D x 75" H					
Top Entry Cabinet	14" W x 33.42" D x 75" H					
Battery Cabinet	26" W x 33.42" D x 75" H					
Battery Cabinet	32" W x 33.42" D x 75" H					
Battery Cabinet	48" W x 33.42" D x 75" H					
Parallel System Bypass Cabinet (480V Only)	28" or 42" W x 33.42" D x 75" H					

MGE Galaxy 5000 Single Line Diagram

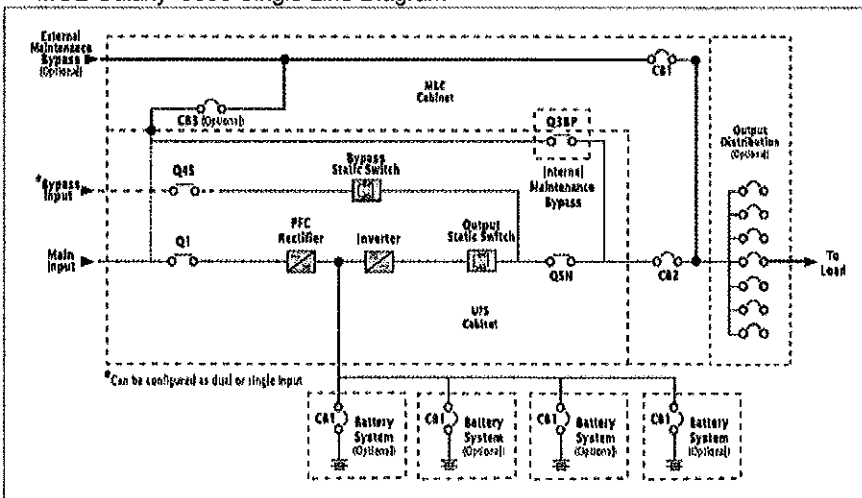

# Facility Planning Data Sheet

## Galaxy 5000 UPS 40 - 130 kVA (208V-208V / 480V-208V / 480V-480V)



UPS Rating		Voltage			Current		Recommended Input AWG		Rec. OCPD		Nominal VDC		Battery kW		Current @ Nbr. V		Current @ Full Load		Typical Dimensions WxHxD		Average Weight Lbs		Floor Loading Lbs/Ft <sup>2</sup>		Heat Rejection BTU/Hr	
kVA	kW	Input	Output	Full Load	Max.	Input AWG	Max.	Input AWG	OCPD	VDC	kW	Nbr. V	Max.	OCPD	W	H	D	Lbs	W	H	D	Lbs	Lbs/Ft <sup>2</sup>	BTU/Hr		
40	36	208	208	111	136	2/0 AWG	175	4/0 AWG	175	432	39	90	111	150	56x75x34	1,110	78	16,850								
40	36	480	208	48	59	4 AWG	80	4 AWG	80	432	39	90	111	150	56x75x34	1,415	99	13,050								
40	36	480	480	48	59	4 AWG	80	4 AWG	80	432	39	90	48	70	28x75x34	882	124	9,250								
50	45	208	208	136	162	4/0 AWG	225	4/0 AWG	225	432	49	113	138	175	56x75x34	1,110	78	21,060								
50	45	480	208	59	70	3 AWG	90	3 AWG	90	432	49	113	138	175	56x75x34	1,415	99	16,310								
50	45	480	480	59	70	3 AWG	90	3 AWG	90	432	49	113	60	80	28x75x34	882	124	11,560								
60	54	208	208	164	203	250 kcmil	300	250 kcmil	300	432	58	135	166	225	56x75x34	1,565	110	25,270								
60	54	480	208	71	88	2 AWG	110	2 AWG	110	432	58	135	166	225	56x75x34	1,785	125	19,570								
60	54	480	480	71	88	2 AWG	110	2 AWG	110	432	58	135	72	90	28x75x34	882	124	13,870								
80	72	208	208	217	256	400 kcmil	350	400 kcmil	350	432	76	180	222	300	56x75x34	1,565	110	33,700								
80	72	480	208	94	111	1/0 AWG	150	1/0 AWG	150	432	76	180	222	300	56x75x34	1,785	125	26,100								
80	72	480	480	94	111	1/0 AWG	150	1/0 AWG	150	432	76	180	96	125	28x75x34	882	124	18,500								
100	90	208	208	270	332	600 kcmil	450	600 kcmil	450	432	97	225	277	350	56x75x34	1,944	136	38,610								
100	90	480	208	117	150	3/0 AWG	200	3/0 AWG	200	432	97	225	277	350	56x75x34	2,565	180	29,110								
100	90	480	480	117	150	3/0 AWG	200	3/0 AWG	200	432	97	225	120	150	28x75x34	1,146	161	19,610								
130	117	208	208	348	420	1000 kcmil	600	1000 kcmil	600	432	126	293	360	450	56x75x34	1,944	136	50,190								
130	117	480	208	151	182	4/0 AWG	250	4/0 AWG	250	432	126	293	360	450	56x75x34	2,565	180	37,840								
130	117	480	480	151	182	4/0 AWG	250	4/0 AWG	250	432	126	293	156	200	28x75x34	1,146	161	25,490								

- Input current based on full rated output load.
- Maximum (Max.) current is for duration of battery recharge.
- Input and bypass cables must be run in separate conduits from output cables. Not more than three conductors in raceway assumed; ambient temperature of 88°F assumed.
- If initial load is less than UPS' rated output, it is recommended that AC input, battery, and AC output wiring and overcurrent protection be sized to UPS' full load rating to accommodate possible future expansion.
- Nominal battery voltage is shown at 2.0 volts/cell per NEC 48-2.
- DC cables should be sized for a total maximum of less than 1% of CB rating.
- OCPD = Overcurrent Protection Device. Recommended represents 125% of nominal fullload current (continuous) per NEC 215.
- Minimum-sized grounding conductors to be per NEC 250-122. Parity-sized ground conductors are recommended. Neutral conductors to be sized for full capacity per NEC 310-15(b)(4).
- Wiring requirements:
  - AC Input/Output: 3Ø, 3 or 4 wire + ground, depending on UPS configuration.
  - DC Input: 2 wire (positive and negative) + ground
- See Installation Manual and submittal drawings for specific instructions.
- DC Input: 2 wire (positive and negative) + ground

- All wiring to be in accordance with all applicable national and/or local electrical codes.
  - Minimum access clearance per UPS drawings.
  - Top or bottom cable entry through removable access plates. Punch plates to suit conduit size, then replace.
  - Control wiring and power wiring must be run in separate conduit.
  - Weights and dimensions shown do not include battery cabinet(s), distribution cabinet(s), or other options.
  - Backup emergency generator must be properly sized for UPS application and equipped with an isochronous governor for frequency regulation, and a UPS-compatible voltage regulator for voltage stability.
  - If site configuration requires an external maintenance bypass, phase parity between UPS input and UPS bypass must be ensured. Consult MGE applications engineer.
  - References are per NEC 1999. Consult local codes for possible variations.
- Additional Notes:
- Temperature rating of conductors: 90°C (194°F). Reference NEC Table 310-16, 75°C column, using copper conductors. 75°C (167°F) cable terminal conductors assumed.

# State of West Virginia VENDOR PREFERENCE CERTIFICATE

Certification and application\* is hereby made for Preference in accordance with *West Virginia Code*, §5A-3-37. (Does not apply to construction contracts). *West Virginia Code*, §5A-3-37, provides an opportunity for qualifying vendors to request (at the time of bid) preference for their residency status. Such preference is an evaluation method only and will be applied only to the cost bid in accordance with the *West Virginia Code*. This certificate for application is to be used to request such preference. The Purchasing Division will make the determination of the Resident Vendor Preference, if applicable.

- 1. **Application is made for 2.5% resident vendor preference for the reason checked:**  
 Bidder is an individual resident vendor and has resided continuously in West Virginia for four (4) years immediately preceding the date of this certification; or,  
 Bidder is a partnership, association or corporation resident vendor and has maintained its headquarters or principal place of business continuously in West Virginia for four (4) years immediately preceding the date of this certification; or 80% of the ownership interest of Bidder is held by another individual, partnership, association or corporation resident vendor who has maintained its headquarters or principal place of business continuously in West Virginia for four (4) years immediately preceding the date of this certification; or,  
 Bidder is a nonresident vendor which has an affiliate or subsidiary which employs a minimum of one hundred state residents and which has maintained its headquarters or principal place of business within West Virginia continuously for the four (4) years immediately preceding the date of this certification; or,
- 2. **Application is made for 2.5% resident vendor preference for the reason checked:**  
 Bidder is a resident vendor who certifies that, during the life of the contract, on average at least 75% of the employees working on the project being bid are residents of West Virginia who have resided in the state continuously for the two years immediately preceding submission of this bid; or,
- 3. **Application is made for 2.5% resident vendor preference for the reason checked:**  
 Bidder is a nonresident vendor employing a minimum of one hundred state residents or is a nonresident vendor with an affiliate or subsidiary which maintains its headquarters or principal place of business within West Virginia employing a minimum of one hundred state residents who certifies that, during the life of the contract, on average at least 75% of the employees or Bidder's affiliate's or subsidiary's employees are residents of West Virginia who have resided in the state continuously for the two years immediately preceding submission of this bid; or,
- 4. **Application is made for 5% resident vendor preference for the reason checked:**  
 Bidder meets either the requirement of both subdivisions (1) and (2) or subdivision (1) and (3) as stated above; or,
- 5. **Application is made for 3.5% resident vendor preference who is a veteran for the reason checked:**  
 Bidder is an individual resident vendor who is a veteran of the United States armed forces, the reserves or the National Guard and has resided in West Virginia continuously for the four years immediately preceding the date on which the bid is submitted; or,
- 6. **Application is made for 3.5% resident vendor preference who is a veteran for the reason checked:**  
 Bidder is a resident vendor who is a veteran of the United States armed forces, the reserves or the National Guard, if, for purposes of producing or distributing the commodities or completing the project which is the subject of the vendor's bid and continuously over the entire term of the project, on average at least seventy-five percent of the vendor's employees are residents of West Virginia who have resided in the state continuously for the two immediately preceding years.

Bidder understands if the Secretary of Revenue determines that a Bidder receiving preference has failed to continue to meet the requirements for such preference, the Secretary may order the Director of Purchasing to: (a) reject the bid; or (b) assess a penalty against such Bidder in an amount not to exceed 5% of the bid amount and that such penalty will be paid to the contracting agency or deducted from any unpaid balance on the contract or purchase order.

By submission of this certificate, Bidder agrees to disclose any reasonably requested information to the Purchasing Division and authorizes the Department of Revenue to disclose to the Director of Purchasing appropriate information verifying that Bidder has paid the required business taxes, provided that such information does not contain the amounts of taxes paid nor any other information deemed by the Tax Commissioner to be confidential.

**Under penalty of law for false swearing (West Virginia Code, §61-5-3), Bidder hereby certifies that this certificate is true and accurate in all respects; and that if a contract is issued to Bidder and if anything contained within this certificate changes during the term of the contract, Bidder will notify the Purchasing Division in writing immediately.**

**Bidder:** Verizon Business Network Services Inc.      **Signed:** *Patricia L Myers*  
on behalf of Verizon Select Services Inc.

**Date:** 7/4/11      **Title:** \_\_\_\_\_      **Patricia L Myers**  
Manager

\*Check any combination of preference consideration(s) indicated above, which you are entitled to receive. Pricing/Contract Management



STATE OF WEST VIRGINIA  
Purchasing Division

**PURCHASING AFFIDAVIT**

**West Virginia Code §5A-3-10a states:** No contract or renewal of any contract may be awarded by the state or any of its political subdivisions to any vendor or prospective vendor when the vendor or prospective vendor or a related party to the vendor or prospective vendor is a debtor and the debt owned is an amount greater than one thousand dollars in the aggregate

**DEFINITIONS:**

"Debt" means any assessment, premium, penalty, fine, tax or other amount of money owed to the state or any of its political subdivisions because of a judgment, fine, permit violation, license assessment, defaulted workers' compensation premium, penalty or other assessment presently delinquent or due and required to be paid to the state or any of its political subdivisions, including any interest or additional penalties accrued thereon.

"Debtor" means any individual, corporation, partnership, association, Limited Liability Company or any other form or business association owing a debt to the state or any of its political subdivisions. "Political subdivision" means any county commission; municipality; county board of education; any instrumentality established by a county or municipality; any separate corporation or instrumentality established by one or more counties or municipalities, as permitted by law; or any public body charged by law with the performance of a government function or whose jurisdiction is coextensive with one or more counties or municipalities. "Related party" means a party, whether an individual, corporation, partnership, association, limited liability company or any other form or business association or other entity whatsoever, related to any vendor by blood, marriage, ownership or contract through which the party has a relationship of ownership or other interest with the vendor so that the party will actually or by effect receive or control a portion of the benefit, profit or other consideration from performance of a vendor contract with the party receiving an amount that meets or exceed five percent of the total contract amount.

**EXCEPTION:** The prohibition of this section does not apply where a vendor has contested any tax administered pursuant to chapter eleven of this code, workers' compensation premium, permit fee or environmental fee or assessment and the matter has not become final or where the vendor has entered into a payment plan or agreement and the vendor is not in default of any of the provisions of such plan or agreement.

Under penalty of law for false swearing (*West Virginia Code* §61-5-3), it is hereby certified that the vendor affirms and acknowledges the information in this affidavit and is in compliance with the requirements as stated.

**WITNESS THE FOLLOWING SIGNATURE**

Vendor's Name: Verizon Business Network Services Inc. on behalf of Verizon Select Services Inc.

Authorized Signature: *Patricia Myers* Date: 1/14/11

State of Mississippi

County of Hinds, to-wit:

Taken, subscribed, and sworn to before me this 14 day of January, 2011.

My Commission expires 08 February, 2013.

**AFFIX SEAL HERE**

**NOTARY PUBLIC** *Chimera L. Sutton*

