



State of West Virginia
 Department of Administration
 Purchasing Division
 2019 Washington Street East
 Post Office Box 50130
 Charleston, WV 25305-0130

Request for Quotation

RFQ NUMBER
 ISCL0048

PAGE
 1

ADDRESS CORRESPONDENCE TO ATTENTION OF
 KRISTA FERRELL
 304-558-2596

RFQ COPY

TYPE NAME/ADDRESS HERE

*Hickman Electric Corp
 701 N. 3rd. St.
 Sutton, WV 26601*

DEPARTMENT OF ADMINISTRATION
 IS&C - COMMUNICATIONS
 1900 KANAWHA BLVD. E.
 BUILDING 5, 10TH FLOOR
 CHARLESTON, WV
 25305 304-558-5472

DATE PRINTED	TERMS OF SALE	SHIP VIA	FOB	FREIGHT TERMS
12/10/2010				

BID OPENING DATE: 01/12/2011 BID OPENING TIME 01:30PM

LINE	QUANTITY	UOF	CAT NO	ITEM NUMBER	UNIT PRICE	AMOUNT
0001	1	EA		287-54	\$ 94,900.00	\$ 94,900.00
<p>THREE PHASE UNINTERRUPTIBLE POWER SUPPLY <i>Alternate (equal) - APC/MGE</i></p> <p>REQUEST FOR QUOTATION (RFQ)</p> <p>THE WEST VIRGINIA STATE PURCHASING DIVISION FOR THE AGENCY, THE WEST VIRGINIA OFFICE OF TECHNOLOGY, IS SOLICITING BIDS TO PROVIDE AND INSTALL ONE (1) NEW LEIBERT SERIES 80KVA NX THREE PHASE UNINTERRUPTIBLE POWER SUPPLY, MODEL 38SA081A0A00 (OR EQUAL) PER THE ATTACHED SPECIFICATIONS.</p> <p>TECHNICAL QUESTIONS MUST BE SUBMITTED IN WRITING TO KRISTA FERRELL IN THE WEST VIRGINIA STATE PURCHASING DIVISION VIA MAIL AT THE ADDRESS SHOWN IN THE BODY OF THIS RFQ, VIA FAX AT 304-558-4115, OR VIA EMAIL AT KRISTA.S.FERRELL@WV.GOV. DEADLINE FOR ALL TECHNICAL QUESTIONS IS WEDNESDAY, DECEMBER 22, 2010 AT THE CLOSE OF BUSINESS. ALL TECHNICAL QUESTIONS RECEIVED WILL BE ANSWERED BY FORMAL ADDENDUM TO BE ISSUED BY THE PURCHASING DIVISION AFTER THE DEADLINE HAS LAPSED.</p> <p>NOTICE TO PROCEED: THE INSTALLATION OF THE EQUIPMENT SHALL BE PERFORMED WITHIN 60 CALENDAR DAYS AFTER THE NOTICE TO PROCEED IS RECEIVED. THE RECEIVED PURCHASE ORDER SHALL SERVE AS THE NOTICE TO PROCEED.</p> <p>BANKRUPTCY: IN THE EVENT THE VENDOR/CONTRACTOR FILES FOR BANKRUPTCY PROTECTION, THE STATE MAY DEEM THE CONTRACT NULL AND VOID, AND TERMINATE SUCH CONTRACT WITHOUT FURTHER ORDER.</p>						

RECEIVED

2011 JAN 20 PM 12:29

WV PURCHASING DIVISION

SIGNATURE <i>Randy Hart</i>				SEE REVERSE SIDE FOR TERMS AND CONDITIONS		TELEPHONE 304-765-5176		DATE 1-18-11	
TITLE <i>President</i>		FEN 55-060-3639-001		ADDRESS CHANGES TO BE NOTED ABOVE					

WHEN RESPONDING TO RFQ, INSERT NAME AND ADDRESS IN SPACE ABOVE LABELED 'VENDOR'

GENERAL TERMS & CONDITIONS REQUEST FOR QUOTATION (RFQ) AND REQUEST FOR PROPOSAL (RFP)

1. Awards will be made in the best interest of the State of West Virginia.
2. The State may accept or reject in part, or in whole, any bid.
3. Prior to any award, the apparent successful vendor must be properly registered with the Purchasing Division and have paid the required \$125 fee.
4. All services performed or goods delivered under State Purchase Order/Contracts are to be continued for the term of the Purchase Order/Contracts, contingent upon funds being appropriated by the Legislature or otherwise being made available. In the event funds are not appropriated or otherwise available for these services or goods this Purchase Order/Contract becomes void and of no effect after June 30.
5. Payment may only be made after the delivery and acceptance of goods or services.
6. Interest may be paid for late payment in accordance with the *West Virginia Code*.
7. Vendor preference will be granted upon written request in accordance with the *West Virginia Code*.
8. The State of West Virginia is exempt from federal and state taxes and will not pay or reimburse such taxes.
9. The Director of Purchasing may cancel any Purchase Order/Contract upon 30 days written notice to the seller.
10. The laws of the State of West Virginia and the *Legislative Rules* of the Purchasing Division shall govern the purchasing process.
11. Any reference to automatic renewal is hereby deleted. The Contract may be renewed only upon mutual written agreement of the parties.
12. **BANKRUPTCY:** In the event the vendor/contractor files for bankruptcy protection, the State may deem this contract null and void, and terminate such contract without further order.
13. **HIPAA BUSINESS ASSOCIATE ADDENDUM:** The West Virginia State Government HIPAA Business Associate Addendum (BAA), approved by the Attorney General, is available online at www.state.wv.us/admin/purchase/vrc/hipaa.htm and is hereby made part of the agreement. Provided that the Agency meets the definition of a Cover Entity (45 CFR §160.103) and will be disclosing Protected Health Information (45 CFR §160.103) to the vendor.
14. **CONFIDENTIALITY:** The vendor agrees that he or she will not disclose to anyone, directly or indirectly, any such personally identifiable information or other confidential information gained from the agency, unless the individual who is the subject of the information consents to the disclosure in writing or the disclosure is made pursuant to the agency's policies, procedures, and rules. Vendor further agrees to comply with the Confidentiality Policies and Information Security Accountability Requirements, set forth in <http://www.state.wv.us/admin/purchase/privacy/noticeConfidentiality.pdf>.
15. **LICENSING:** Vendors must be licensed and in good standing in accordance with any and all state and local laws and requirements by any state or local agency of West Virginia, including, but not limited to, the West Virginia Secretary of State's Office, the West Virginia Tax Department, and the West Virginia Insurance Commission. The vendor must provide all necessary releases to obtain information to enable the director or spending unit to verify that the vendor is licensed and in good standing with the above entities.
16. **ANTITRUST:** In submitting a bid to any agency for the State of West Virginia, the bidder offers and agrees that if the bid is accepted the bidder will convey, sell, assign or transfer to the State of West Virginia all rights, title and interest in and to all causes of action it may now or hereafter acquire under the antitrust laws of the United States and the State of West Virginia for price fixing and/or unreasonable restraints of trade relating to the particular commodities or services purchased or acquired by the State of West Virginia. Such assignment shall be made and become effective at the time the purchasing agency tenders the initial payment to the bidder.

I certify that this bid is made without prior understanding, agreement, or connection with any corporation, firm, limited liability company, partnership, or person or entity submitting a bid for the same material, supplies, equipment or services and is in all respects fair and without collusion or fraud. I further certify that I am authorized to sign the certification on behalf of the bidder or this bid.

INSTRUCTIONS TO BIDDERS

1. Use the quotation forms provided by the Purchasing Division. Complete all sections of the quotation form.
2. Items offered must be in compliance with the specifications. Any deviation from the specifications must be clearly indicated by the bidder. Alternates offered by the bidder as **EQUAL** to the specifications must be clearly defined. A bidder offering an alternate should attach complete specifications and literature to the bid. The Purchasing Division may waive minor deviations to specifications.
3. Unit prices shall prevail in case of discrepancy. All quotations are considered F.O.B. destination unless alternate shipping terms are clearly identified in the quotation.
4. All quotations must be delivered by the bidder to the office listed below prior to the date and time of the bid opening. Failure of the bidder to deliver the quotations on time will result in bid disqualifications: Department of Administration, Purchasing Division, 2019 Washington Street East, P.O. Box 50130, Charleston, WV 25305-0130
5. Communication during the solicitation, bid, evaluation or award periods, except through the Purchasing Division, is strictly prohibited (W.Va. C.S.R. §148-1-6.6).



State of West Virginia
 Department of Administration
 Purchasing Division
 2019 Washington Street East
 Post Office Box 50130
 Charleston, WV 25305-0130

Request for Quotation

RFQ NUMBER
ISCL0048

PAGE
2

ADDRESS CORRESPONDENCE TO ATTENTION OF
KRISTA FERRELL
304-558-2596

RFQ COPY

TYPE NAME/ADDRESS HERE

Hickman Electric Corp.
701 N. 3rd St.
Sutton, WV 26601

DEPARTMENT OF ADMINISTRATION
 IS&C - COMMUNICATIONS
 1900 KANAWHA BLVD. E.
 BUILDING 5, 10TH FLOOR
 CHARLESTON, WV
 25305 304-558-5472

DATE PRINTED	TERMS OF SALE	SHIP VIA	FOB	FREIGHT TERMS
12/10/2010				

BID OPENING DATE: **01/12/2011** BID OPENING TIME **01:30PM**

LINE	QUANTITY	UQP	CAT NO	ITEM NUMBER	UNIT PRICE	AMOUNT
<p>NOTICE</p> <p>A SIGNED BID MUST BE SUBMITTED TO:</p> <p>DEPARTMENT OF ADMINISTRATION PURCHASING DIVISION BUILDING 15 2019 WASHINGTON STREET, EAST CHARLESTON, WV 25305-0130</p> <p>THE BID SHOULD CONTAIN THIS INFORMATION ON THE FACE OF THE ENVELOPE OR THE BID MAY NOT BE CONSIDERED:</p> <p>SEALED BID</p> <p>BUYER: KRISTA FERRELL-FILE 21</p> <p>RFQ. NO.: ISCL0048</p> <p>BID OPENING DATE: 01/12/2011</p> <p>BID OPENING TIME: 1:30 PM</p> <p>PLEASE PROVIDE A FAX NUMBER IN CASE IT IS NECESSARY TO CONTACT YOU REGARDING YOUR BID:</p> <p><i>Fax # 304-765-5855</i></p> <p>CONTACT PERSON (PLEASE PRINT CLEARLY): <i>Rodney I. Hickman</i></p>						

SIGNATURE <i>Rodney I. Hickman</i>		TELEPHONE <i>304-765-5176</i>	DATE <i>1-18-11</i>
TITLE <i>President</i>	FEIN <i>55-060-3639-001</i>	ADDRESS CHANGES TO BE NOTED ABOVE	

WHEN RESPONDING TO RFQ, INSERT NAME AND ADDRESS IN SPACE ABOVE LABELED 'VENDOR'



State of West Virginia
 Department of Administration
 Purchasing Division
 2019 Washington Street East
 Post Office Box 50130
 Charleston, WV 25305-0130

Request for Quotation

RFQ NUMBER
ISCL0048

PAGE
3

ADDRESS CORRESPONDENCE TO ATTENTION OF
**KRISTA FERRELL
 304-558-2596**

RFQ COPY

TYPE NAME/ADDRESS HERE

*Hickman Electric Corp.
 701 N. 3rd St.
 Sutton, WV 26601*

DEPARTMENT OF ADMINISTRATION
 IS&C - COMMUNICATIONS
 1900 KANAWHA BLVD. E.
 BUILDING 5, 10TH FLOOR
 CHARLESTON, WV
 25305 304-558-5472

DATE PRINTED	TERMS OF SALE	SHIP VIA	FOB	FREIGHT TERMS
12/10/2010				

BID OPENING DATE: **01/12/2011** BID OPENING TIME **01:30PM**

LINE	QUANTITY	UQP	CAT. NO.	ITEM NUMBER	UNIT PRICE	AMOUNT
<p>***** THIS IS THE END OF RFQ ISCL0048 ***** TOTAL: <u>\$94,900.00</u></p> <p><i>Alternate (equal) - APC/MGE</i></p>						

SEE REVERSE SIDE FOR TERMS AND CONDITIONS

SIGNATURE: *Roch J. Huth* TELEPHONE: **304-765-5176** DATE: **1-18-11**

TITLE: *President* FEIN: **55-060-3639-001** ADDRESS CHANGES TO BE NOTED ABOVE

WHEN RESPONDING TO RFQ, INSERT NAME AND ADDRESS IN SPACE ABOVE LABELED 'VENDOR'

**West Virginia office of Technology
Request for Quotation (RFQ)**

The West Virginia Purchasing Division for the agency WVOT requests quotes to supply and install a new Liebert Series 80kVA Liebert NX Three Phase Uninterruptible Power Supply, model 38SA081A0A00, (or Equal) with the following related hardware and specifications:

The system must include AC bypass voltage 208V (three-phase, three or four wire plus ground).

The system must include AC output voltage 208V (three phase, three or four wire plus ground).

The system must be equal to One (1) 80kVA Liebert NX Three Phase Uninterruptible Power Supply, model 38SA081A0A00, with the following features and characteristics:

The system must have Input Voltage 208VAC (3 wire plus ground) and must have system Output Voltage 208/120VAC (three phase, three or four-wire plus ground) and must include the following features:

- **Integrated Load Bus Sync TM**
- **Softscale technology allows future upgrades up to 120kVA**
- **IGBT pulse-width modulated (PWM) rectifier providing 0.99 input power factor and 4% reflected input current distortion (THD)**
- **Temperature compensated separate battery charger to allow use with valve-regulated lead acid (VRLA), wet cell lead acid, and NiCad battery systems**
- **IGBT pulse-width modulated (PWM) inverter**
- **Automatic continuous duty static transfer switch**
- **Single input, true on-line, double conversion**
- **Field Configurable for dual input (single module systems only)**
- **Internal manual bypass switch**
- **Withstand rating and UPS width: 65kAIC, UPS Module 25.5 inches wide**
- **Digital Signal Processing (DSP) control system**
- **Back-lit LCD Graphic Display with multilingual support and user friendly navigation menu**
- **Alarm History Database**
- **Redundant Cooling Fans**
- **Local EPO with provision for Remote EPO**
- **Three (3) Intellislot Communication Ports**
- **IP 20 enclosure**

- Casters and leveling feet
- Meets ISTA 1B transportation requirements
- Meets FCC Part 15, Class A
- UL and cUL Listed to UL Standard 1778

The system **must** include 1 (One) IS-WEVLB: IntelliSlot Web Card LB. This interface card **must** deliver SNMP, Telnet and web-management capability for enhanced communications and control of Liebert UPS, Power Management or Precision Cooling systems. The card **must** manage a wide range of operating parameters, alarms and notifications, transmitting data over the network.

The system **must** include an External Battery System rated for 66 minutes at a 80kVA load and **must** have the following features:

Two (2) External Battery Cabinet(s) model number: 38BP120XWX1BNS or equal

- Battery Cabinets are shipped separately and include side panels.
- Battery interconnect cable kit type: Left Side of UPS
- Battery Cabinet cable kits include DC wiring as well as control interface wiring.

The system **must** include a Liebert Bypass Distribution Cabinet, model FXC12C6NNG6, or equal with the following features:

- 3-Breaker wrap-around maintenance bypass with interlock by solenoid key release unit (SKRU)
- Distribution, Width and Access Requirements: (2) 225A Breakers, 47In Wide, Front & Rear Access
- Casters and leveling feet

And **shall** include interconnecting cables for bolting the Bypass Distribution cabinet to the right side of the UPS

UPS System Start-up Services, **must** including the following;

Start-up includes one site trip by a LGS customer engineer after the UPS has been installed. The site trip **must** include the following services for one UPS module: non-powered inspection UPS electrical and operational checkout, full parts and labor for any remedial work required on the UPS or battery cabinets, and customer operation training. Start-up also **must** include remedial onsite labor, parts, and travel for the full one-year warranty period. Start-up **shall** be scheduled at the customers designated time.

ADDITIONAL SERVICES TO BE PROVIDED BY THE VENDOR

The vendor **must** describe any power interruptions necessary for the installation of this hardware. If it is found necessary for an additional power outage to

occur, the Data Center Manager **must** be notified at least two weeks before the occurrence. The vendor **must** submit a schedule of dates and times of interruptions in advance so that we can have adequate time to notify end-users.

The vendor **shall** be responsible for all necessary permits, licenses, and inspections as required.

The vendor **shall** be responsible for the maintenance and warranty for all hardware and labor by maintaining a 24/7 helpline for technical issues for the period of one year after installation. A live attendant **shall** be on site within 4 hours from a trouble call being placed.

The vendor **shall** provide training to designated State personnel (not to exceed 6 employees) on the operations of all hardware.

All installation **shall** be completed within 60 day after receiving of purchase order.

INSTALLATION ADDRESS

This System is to be installed at the Disaster Recovery Center located at 89 Richard D. Munnich Dr., Sutton WV.

HOURS OF WORK

The normal working hours for the Office of Technology are 7:30 AM to 5:00 PM, Monday through Friday. However, designated State holidays, weekends, and after hours schedules will be accommodated if given advance notice and permission by the Office of Technology.

PERSONNEL

The Vendor **shall** submit a proposed staffing plan including supervisory personnel to accomplish this work in the designated time frame.

EQUAL EMPLOYMENT OPPORTUNITY

The successful vendor **must** be an Equal Opportunity Employer, and **shall** take all employment actions without regard to an individual's race, color, national origin, ancestry, sex, religion, age, physical handicap, disability, or political affiliation.

CONDUCT AND MANAGEMENT

While employed on this contract, all personnel will remain employees of the vendor. The vendor shall make this condition clearly known to his or her employees and shall be responsible for their conduct and management. The State of West Virginia shall not be considered a re-employer. If a vendor employee displays improper work conduct, unsatisfactory performance, or is deemed to be unqualified to perform the assignment, the Office of Technology may request a replacement employee from the vendor. The Vendor shall be solely responsible for conformity with all applicable health, safety and sanitation standards, laws and regulations at the State's facilities.

SMOKE FREE / DRUG FREE / ALCOHOL FREE

In keeping with the policies of the State of West Virginia, the Vendor must maintain a drug free / alcohol free work environment.

IMMIGRATION REFORM AND CONTROL ACT OF 1986

By submitting this response, the vendor certifies that it does not and will not, during the performance of the contract, employ illegal alien workers or otherwise violate the provisions of the Federal Immigration Reform and Control Act of 1986.

METHOD OF PAYMENT / COMPENSATION

After all work has been satisfactorily completed and accepted by the State of West Virginia as outlined in this contract, the vendor shall transmit an invoice for payment in the amount of the original purchase order. The vendor shall be responsible for all salaries, wages, and related costs. The vendor will be responsible for paying any and all insurance, taxes, overtime, holiday pay, and other unnamed payroll costs, which may arise. If the contractor has not completed the work within the prescribed time frame, the contractor shall be assessed liquidated damages until the work is completed. Liquidated damages shall comprise of a daily penalty of five (5) percent of the total contract award per day until the work is satisfactorily completed.

SUPPORT

The Office of Technology will have an employee available during all installation. Additionally, the Office of Technology will provide a list of contact and support personnel that will be available to the vendor.

By signing below, vendor certifies that all specifications will be followed, that vendor meets all criteria, and will adhere to the schedule if awarded the purchase order.

Total Cost Quote: Ninty Four thousand nine hundred
dollars. \$94,900.00

Print Name

Rocky Hill President

Signature/ Title

Hickman Electric Corporation

Vendors Name

WV004241



State of West Virginia
 Department of Administration
 Purchasing Division
 2019 Washington Street East
 Post Office Box 50130
 Charleston, WV 25305-0130

Request for Quotation

RFQ NUMBER
 ISCL0048

PAGE
 1

ADDRESS CORRESPONDENCE TO ATTENTION OF
 KRISTA FERRELL
 304-558-2596

RFQ COPY
 TYPE NAME/ADDRESS HERE

DEPARTMENT OF ADMINISTRATION
 IS&C - COMMUNICATIONS
 1900 KANAWHA BLVD. E.
 BUILDING 5, 10TH FLOOR
 CHARLESTON, WV
 25305 304-558-5472

DATE PRINTED	TERMS OF SALE	SHIP VIA	FOB	FREIGHT TERMS
12/22/2010				

BID OPENING DATE: 01/20/2011 BID OPENING TIME 01:30PM

LINE	QUANTITY	UCP	CAT NO	ITEM NUMBER	UNIT PRICE	AMOUNT
				ADDENDUM NO. 1		
				THIS ADDENDUM IS ISSUED TO:		
				1.) ADD A MANDATORY PRE-BID MEETING PER THE ATTACHED		
				2.) EXTEND THE DEADLINE FOR TECHNICAL QUESTIONS FROM		
				DECEMBER 22, 2010 TO JANUARY 10, 2010 AT THE CLOSE		
				OF BUSINESS.		
				3.) EXTEND THE BID OPENING DATE FROM JANUARY 12, 2011		
				TO JANUARY 20, 2011 AT 1:30 PM.		
				***** NO OTHER CHANGES *****		
				<i>We Received</i>		
				<i>Rob & Steve</i>		
0001	1	EA		287-54		
				THREE PHASE UNINTERRUPTIBLE POWER SUPPLY		

SEE REVERSE SIDE FOR TERMS AND CONDITIONS

SIGNATURE	TELEPHONE	DATE
TITLE	FEIN	ADDRESS CHANGES TO BE NOTED ABOVE

WHEN RESPONDING TO RFQ, INSERT NAME AND ADDRESS IN SPACE ABOVE LABELED 'VENDOR'



State of West Virginia
 Department of Administration
 Purchasing Division
 2019 Washington Street East
 Post Office Box 50130
 Charleston, WV 25305-0130

Request for Quotation

RFQ NUMBER
ISCL0048

PAGE
1

ADDRESS CORRESPONDENCE TO ATTENTION OF
**KRISTA FERRELL
 304-558-2596**

RFQ COPY
 TYPE NAME/ADDRESS HERE

VENDOR

DEPARTMENT OF ADMINISTRATION

DEPARTMENT OF ADMINISTRATION
 IS&C - COMMUNICATIONS
 1900 KANAWHA BLVD. E.
 BUILDING 5, 10TH FLOOR
 CHARLESTON, WV
 25305 304-558-5472

DATE PRINTED	TERMS OF SALE	SHIP VIA	FOR	FREIGHT TERMS
01/10/2011				

BID OPENING DATE: **01/20/2011** BID OPENING TIME **01:30PM**

LINE	QUANTITY	UOP	QAT NO	ITEM NUMBER	UNIT PRICE	AMOUNT
				ADDENDUM NO. 2		
				THIS ADDENDUM IS ISSUED TO:		
				1.) PROVIDE A COPY OF THE MANDATORY PRE-BID ATTENDEE LIST,		
				2.) PROVIDE CLARIFICATION AS STATED BELOW,		
				"THE ISOLATION TRANSFORMER MUST BE SUPPLIED BY THE VENDOR AS STATE IN THE PRE-BID CONFERENCE ON 01/05/2011."		
				3.) PROVIDE ANSWERS TO ALL TECHNICAL QUESTIONS SUBMITTED IN ACCORDANCE WITH THE PROVISIONS OF THE ORIGINAL REQUEST FOR QUOTATION, ISCL0048.		
				BID OPENING DATE REMAINS: 01/20/2011		
				BID OPENING TIME REMAINS: 1:30 PM		
				***** END ADDENDUM NO. 2 *****		
0001	1	EA		287-54		
				THREE PHASE UNINTERRUPTIBLE POWER SUPPLY		

*We Received
 Rudy J. Rich*

SEE REVERSE SIDE FOR TERMS AND CONDITIONS		
SIGNATURE	TELEPHONE	DATE
TITLE	FEIN	ADDRESS CHANGES TO BE NOTED ABOVE

WHEN RESPONDING TO RFQ, INSERT NAME AND ADDRESS IN SPACE ABOVE LABELED 'VENDOR'

Hickman Electric Corporation
701 N. 3rd. Street
Sutton, WV 26601

Date: 1-20-2011

Buyer: Krista Ferrell-File 21
RFQ. No.: ISCL0048
Bid Opening Date: 01/ 20/ 2011
Bid Opening Time: 1:30 PM

To Whom It May Concern:

We are bidding an alternate equal to the Leibert series that was specified by the RFQ. The alternate equal that we are bidding is an APC/ MGE. They assured us that their unit meets all the specs. We are enclosing a brochure and if considered for the job they will send us a complete set of submittals.

We have received Addendum No. 1 and Addendum No. 2.

Sincerely Yours,

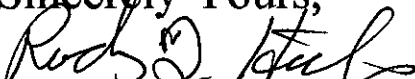
Rodney I. Hickman

President

Hickman Electric Corp.

701 N. 3rd. Street
Sutton, WV 26601

40 to 130 kVA

MGE™ Galaxy™ 5000

Flexible Three Phase Power Protection

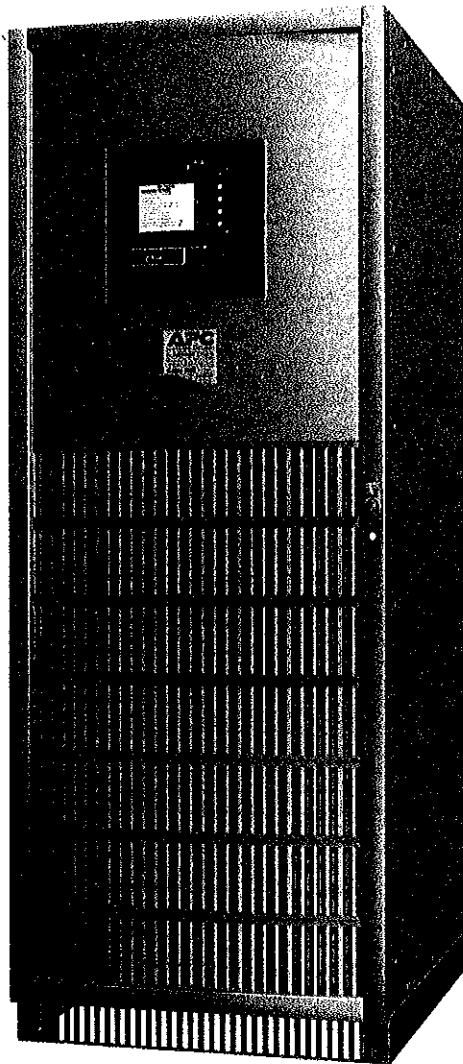

**Performance Three Phase
Power Protection with
Adaptability to Meet the
Unique requirements of
Small to Medium
Datacenters, Buildings and
Facilities**

- > Upgradeable power ranges
- > Internal maintenance bypass
- > Intuitive monitoring
- > Parallel Capable
- > Front access servicing

APC
by Schneider Electric

40 kVA to 130 kVA

High Power Availability

The MGE Galaxy 5000 has been designed for continuous operation

- > Fault tolerance with built-in 100% rated bypass static switch
- > Redundant components for greater reliability
- > High overload capacity to improve downstream discrimination
- > Extended Battery backup times available

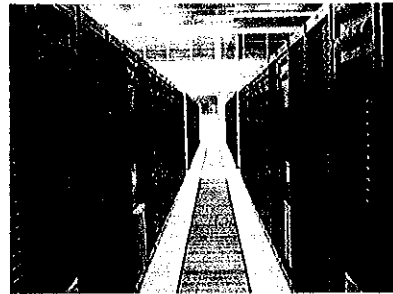

Flexible and Upgradeable

The MGE Galaxy 5000 adapts to your changing needs

- > Expandable Power ranges
- > Parallel up to 6 modules for higher capacity or redundancy
- > Easy integration with networking and monitoring systems
- > A choice of backup times from 5 minutes to 8 hours
- > Compatible with inductive and leading power factor loads
- > Field Upgradeable from Single to Parallel

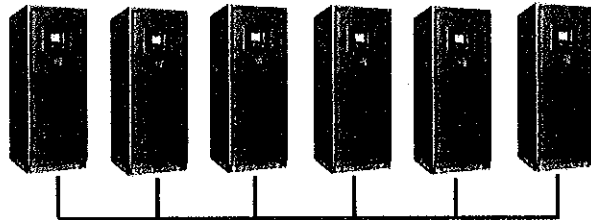

Low total cost of ownership

The MGE Galaxy 5000 helps to minimize your infrastructure costs

- > Small footprint
- > Power factor corrected input prevents the need for oversizing cables, circuit breakers and generator
- > Efficiency in on-line double conversion mode up to 93.5%



Features that make the difference

IGBT based technology for Power Quality

Supplies clean, stable power to sensitive loads ensuring critical power protection, optimum performance, and extended life

Parallel Operation

Connect as many as 6 units in parallel for capacity and redundancy to grow with your power requirements

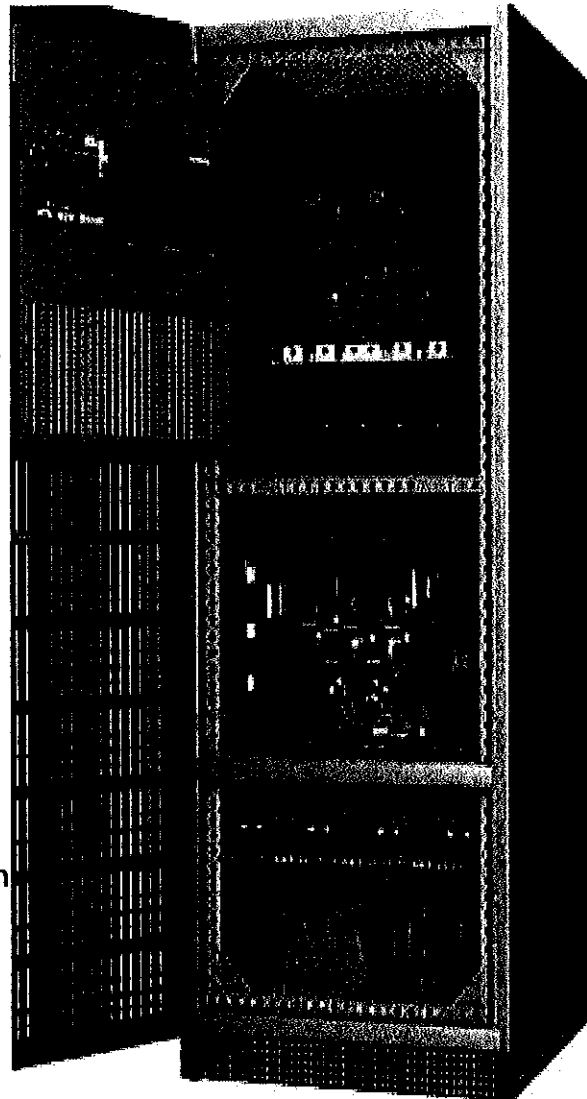

Dual Input

Allows for connection to two separate input sources for increased availability

Redundant components

Back up for the Main Intelligence Module provides increased availability

Built-In Static and maintenance Bypass

Enables the UPS to transfer the load to utility power, without interruption, in the event of heavy overload or fault

Optional Auxiliary Gear

- > Input/Output transformers
 - 208V/220V/480V/600V
- > Wall Mount Battery Disconnect
- > Matching Battery Cabinets
 - Up to four (4) enclosures can be connected to the UPS for extended run times of up to 4 hours
- > Distribution
 - Panel board
 - Sub Feed Breakers
- > Matching External Maintenance Bypass
- > Parallel System Bypass Cabinets
- > Communication cards
 - RS232 / RS485 / Dry Contact
 - Network Management Card
- > Top Entry Cabinets
- > 65kAIC rating
- > Seismic Brackets
- > Remote Alarm Panel

Technical characteristics

Rated power (kVA/KW)	40/36	50/45	60/54	80/72	100/90	130/117
Normal AC Input						
Input Voltage (V)	480V Core, 3 Wire + G (220V, 208V, 600V w/ Aux Transformer 4 Wire + G)					
Frequency	60Hz +/- 5%					
Power Factor	< 0.99					
Current Distortion (THDI)	< 5%					
Bypass AC Input						
Bypass Overload	10x nominal current for 1 cycle					
Load Output						
Output Voltage	480V Core, 3 Wire + G (220V, 208V, 600V w/ Aux Transformer 4 Wire + G)					
Frequency	60Hz					
Voltage Regulation	+/- 1.0% balance load , +/- 2.5% unbalanced load					
Voltage Transient Response	+/- 5% for 100% step load, +/-1% for loss or return of AC input					
Voltage Recovery Time	Within 1% of nominal within 1 cycle					
Voltage Distortion	<1% L-L and L-N for non-linear loads (<2% max)					
Inverter Overload	150% for 1 min, 125% for 10min					
Heat Rejection (BTU) @480V	9248	11560	13872	18496	19607	25489
Overall efficiency						
Double conversion mode	Up to 94%					
Environmental						
Storage temperature	-20C to +45C (-4F to 113F)					
Operating temperature	UPS 0-40C (32F to 104F), Battery 25C(77F)					
Operating altitude	1000 m					
Dimensions and Weights						
Dimensions and weights	28" W x 33.42" D x 75" H (882 lbs)			28" W x 33.42" D x 75" H (1146 lbs)		
Matching Maintenance Bypass	28" W x 33.42" D x 75" H					
Transformer Cabinet	28" W x 33.42" D x 75" H					
Distribution Cabinet	42" W x 33.42" D x 75" H					
Top Entry Cabinet	14" W x 33.42" D x 75" H					
Battery Cabinet	26" W x 33.42" D x 75" H					
Battery Cabinet	32" W x 33.42" D x 75" H					
Battery Cabinet	48" W x 33.42" D x 75" H					
Parallel System Bypass Cabinet (480V Only)	28" or 42" W x 33.42" D x 75" H					

MGE Galaxy 5000 Single Line Diagram

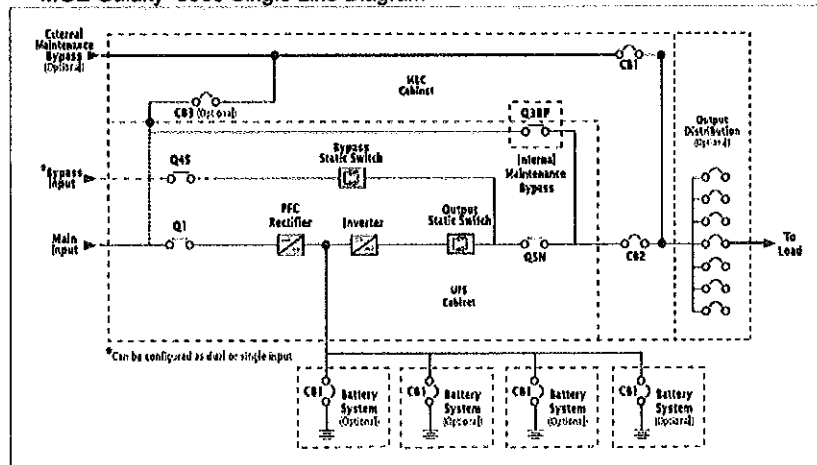

Facility Planning Data Sheet

Galaxy 5000 UPS 40 - 130 kVA (208V-208V / 480V-208V / 480V-480V)



UPS Rating		Voltage			Current		UPS AC Input			Battery System			AC Output			Mechanical Data		
kVA	kW	Input	Output	Full Load	Max.	Rec. OCPD	Recommended Input AWG	Rec. OCPD	Nominal VDC	Battery kW	Current @ Nom. V	Current @ Full Load	Typical Dimensions WxHxD	Average Weight Lbs	Floor Loading Lbs/Ft ²	Heat Rejection BTU/Hr		
40	36	208	208	111	136	175	2/0 AWG	175	432	39	90	111	56x75x34	1,110	78	16,950		
40	36	480	208	48	59	80	4 AWG	80	432	39	90	111	56x75x34	1,415	99	13,050		
40	36	480	480	48	59	80	4 AWG	80	432	39	90	48	28x75x34	882	124	9,250		
50	45	208	208	136	162	225	4/0 AWG	225	432	49	113	138	56x75x34	1,110	78	21,060		
50	45	480	208	59	70	90	3 AWG	90	432	49	113	138	56x75x34	1,415	99	16,310		
50	45	480	480	59	70	90	3 AWG	90	432	49	113	80	28x75x34	882	124	11,560		
60	54	208	208	164	203	300	250 kcmil	300	432	58	135	166	56x75x34	1,565	110	25,270		
60	54	480	208	71	88	110	2 AWG	110	432	58	135	166	56x75x34	1,785	125	19,570		
60	54	480	480	71	88	110	2 AWG	110	432	58	135	72	28x75x34	882	124	13,870		
80	72	208	208	217	256	350	400 kcmil	350	432	78	180	222	56x75x34	1,565	110	33,700		
80	72	480	208	94	111	150	1/0 AWG	150	432	78	180	222	56x75x34	1,785	125	26,100		
80	72	480	480	94	111	150	1/0 AWG	150	432	78	180	96	28x75x34	882	124	18,500		
100	90	208	208	270	332	450	600 kcmil	450	432	97	225	277	56x75x34	1,944	136	38,610		
100	90	480	208	117	150	200	3/0 AWG	200	432	97	225	277	56x75x34	2,565	180	29,110		
100	90	480	480	117	150	200	3/0 AWG	200	432	97	225	120	28x75x34	1,146	161	19,610		
130	117	208	208	348	420	600	1000 kcmil	600	432	126	293	360	56x75x34	1,944	136	50,190		
130	117	480	208	151	182	250	4/0 AWG	250	432	126	293	360	56x75x34	2,565	180	37,840		
130	117	480	480	151	182	250	4/0 AWG	250	432	126	293	156	28x75x34	1,146	161	25,490		

- Input current based on full rated output load.
 - Maximum (Max.) current is for duration of battery recharge.
 - Input and bypass cables must be run in separate conduits from output cables. Not more than three conductors in raceway assumed; ambient temperature of 86°F assumed.
 - If initial load is less than UPS' rated output, it is recommended that AC input, battery, and AC output wiring and overcurrent protection be sized to UPS' full load rating to accommodate possible future expansion.
 - Nominal battery voltage is shown at 2.0 volts/cell per NEC 480-2.
 - DC cables should be sized for a total maximum of less than 1% of CB rating.
 - OCPD = Overcurrent Protection Device. Recommended represents 125% of nominal full load current (continuous) per NEC 215.
 - Minimum-sized grounding conductors to be sized for full capacity per NEC 310-15(b)(4).
 - Wiring requirements:
 - AC Input/Output: 3Ø, 3 or 4 wire + ground, depending on UPS configuration.
 - See Installation Manual and submittal drawings for specific instructions.
 - DC Input: 2 wire (positive and negative) + ground
- RATINGS OF CABLES AND OVERCURRENT DEVICES SUPPLIED FOR INFORMATION ONLY. USER TO CONSULT WITH THEIR ENGINEERING SERVICES BEFORE ADOPTING.**
- All wiring to be in accordance with all applicable national and/or local electrical codes.
 - Minimum access clearance per UPS drawings.
 - Top or bottom cable entry through removable access plates. Punch plates to suit conduit size, then replace.
 - Control wiring and power wiring must be run in separate conduit.
 - Weights and dimensions shown do not include battery cabinet(s), distribution cabinet(s), or other options.
 - Backup emergency generator must be properly sized for UPS application and equipped with an isochronous governor for frequency regulation, and a UPS-compatible voltage regulator for voltage stability.
 - If site configuration requires an external maintenance bypass, phase parity between UPS input and UPS bypass must be ensured. Consult MGE applications engineer.
 - References are per NEC 1989. Consult local codes for possible variations.
- Additional Notes:
 A. Temperature rating of conductors: 90°C (194°F). Reference NEC Table 310-16, 75°C column, using copper conductors. 75°C (167°F) cable terminal conductors assumed.

CONTRACTOR LICENSE

Authorized by the

West Virginia Contractor Licensing Board

Number: WV004241

Classification:

ELECTRICAL
GENERAL BUILDING
HEATING, VENTILATING & COOLING
MULTIFAMILY
PLUMBING
RESIDENTIAL
SPECIALTY

HICKMAN ELECTRIC CORPORATION
DBA HICKMAN ELECTRIC CORPORATION
701 N 3RD ST
SUTTON, WV 26601-1231

Date Issued

Expiration Date

SEPTEMBER 12, 2010	SEPTEMBER 12, 2011
--------------------	--------------------

Authorized Company Signature

Chair, West Virginia Contractor
Licensing Board



WEST VIRGINIA
CONTRACTOR
LICENSING
BOARD

This license, or a copy thereof, must be posted in a conspicuous place at every construction site where work is being performed. This license number must appear in all advertisements, on all bid submissions and on all fully executed and binding contracts. This license cannot be assigned or transferred by licensee. Issued under provisions of West Virginia Code, Chapter 21, Article 11.

BID BOND

KNOW ALL MEN BY THESE PRESENTS, That we, the undersigned, Hickman Electric Corporation
of Sutton, WV, as Principal, and Old Republic Surety Company
of Milwaukee, WI, a corporation organized and existing under the laws of the State of
WI with its principal office in the City of Milwaukee, as Surety, are held and firmly bound unto the State
of West Virginia, as Obligee, in the penal sum of Five Percent of Amount Bid (\$ 5%) for the payment of which,
well and truly to be made, we jointly and severally bind ourselves, our heirs, administrators, executors, successors and assigns.

The Condition of the above obligation is such that whereas the Principal has submitted to the Purchasing Section of the
Department of Administration a certain bid or proposal, attached hereto and made a part hereof, to enter into a contract in writing for
Provide and Install 1 New Power Supply for Disaster Recovery Center, Sutton, WV

NOW THEREFORE,

(a) If said bid shall be rejected, or
(b) If said bid shall be accepted and the Principal shall enter into a contract in accordance with the bid or proposal attached
hereto and shall furnish any other bonds and insurance required by the bid or proposal, and shall in all other respects perform the
agreement created by the acceptance of said bid, then this obligation shall be null and void, otherwise this obligation shall remain in full
force and effect. It is expressly understood and agreed that the liability of the Surety for any and all claims hereunder shall, in no event,
exceed the penal amount of this obligation as herein stated.

The Surety, for the value received, hereby stipulates and agrees that the obligations of said Surety and its bond shall be in no
way impaired or affected by any extension of the time within which the Obligee may accept such bid, and said Surety does hereby
waive notice of any such extension.

IN WITNESS WHEREOF, Principal and Surety have hereunto set their hands and seals, and such of them as are corporations
have caused their corporate seals to be affixed hereunto and these presents to be signed by their proper officers, this
20th day of January, 2011.

Principal Corporate Seal



Hickman Electric Corporation

(Name of Principal)

By Rocky J. Hick

(Must be President or
Vice President)

President
(Title)

Surety Corporate Seal

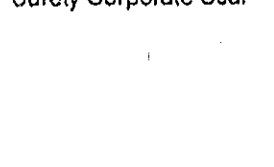

Old Republic Surety Company

(Name of Surety)

By: Andrew K. Teeter

Andrew K. Teeter

Attorney-in-Fact

IMPORTANT – Surety executing bonds must be licensed in West Virginia to transact surety insurance. Corporate seals must be affixed,
and a power of attorney must be attached.

KNOW ALL MEN BY THESE PRESENTS: That OLD REPUBLIC SURETY COMPANY, a Wisconsin stock insurance corporation, does make, constitute and appoint:

ANDREW K. TEETER, KIMBERLY L. MILES, DOUGLAS P. TAYLOR, DONNA J. PRICE, OF CHARLESTON, WV

its true and lawful Attorney(s)-in-Fact, with full power and authority, not exceeding \$10,000,000, for and on behalf of the company as surety, to execute and deliver and affix the seal of the company thereto (if a seal is required), bonds, undertakings, recognizances or other written obligations in the nature thereof, (other than bail bonds, bank depository bonds, mortgage deficiency bonds, mortgage guaranty bonds, guarantees of installment paper and note guaranty bonds, self-insurance workers compensation bonds guaranteeing payment of benefits, asbestos abatement contract bonds, waste management bonds, hazardous waste remediation bonds or black lung bonds), as follows:

ALL WRITTEN INSTRUMENTS IN AN AMOUNT NOT TO EXCEED AN AGGREGATE OF FIVE MILLION DOLLARS (\$5,000,000) ----- FOR ANY SINGLE OBLIGATION, REGARDLESS OF THE NUMBER OF INSTRUMENTS ISSUED FOR THE OBLIGATION.

and to bind OLD REPUBLIC SURETY COMPANY thereby, and all of the acts of said Attorneys-in-Fact, pursuant to these presents, are ratified and confirmed. This document is not valid unless printed on colored background and is multi-colored. This appointment is made under and by authority of the board of directors at a special meeting held on February 18, 1982. This Power of Attorney is signed and sealed by facsimile under and by the authority of the following resolutions adopted by the board of directors of the OLD REPUBLIC SURETY COMPANY on February 18, 1982.

RESOLVED that the president, any vice-president, or assistant vice president in conjunction with the secretary or any assistant secretary, may appoint attorneys-in-fact or agents with authority as defined or limited in the instrument evidencing the appointment in each case, for and on behalf of the company to execute and deliver and affix the seal of the company to bonds, undertakings, recognizances, and suretyship obligations of all kinds; and said officers may remove any such attorney-in-fact or agent and revoke any Power of Attorney previously granted to such person.

RESOLVED FURTHER, that any bond, undertaking, recognizance, or suretyship obligation shall be valid and binding upon the Company

- (i) when signed by the president, any vice president or assistant vice president, and attested and sealed (if a seal be required) by any secretary or assistant secretary; or
- (ii) when signed by the president, any vice president or assistant vice president, secretary or assistant secretary, and countersigned and sealed (if a seal be required) by a duly authorized attorney-in-fact or agent; or
- (iii) when duly executed and sealed (if a seal be required) by one or more attorneys-in-fact or agents pursuant to and within the limits of the authority evidenced by the Power of Attorney issued by the company to such person or persons.

RESOLVED FURTHER, that the signature of any authorized officer and the seal of the company may be affixed by facsimile to any Power of Attorney or certification thereof authorizing the execution and delivery of any bond, undertaking, recognizance, or other suretyship obligations of the company, and such signature and seal when so used shall have the same force and effect as though manually affixed.

IN WITNESS WHEREOF, OLD REPUBLIC SURETY COMPANY has caused these presents to be signed by its proper officer, and its corporate seal to be affixed this 19TH day of MAY, 2010.

[Signature]

Assistant Secretary
STATE OF WISCONSIN, COUNTY OF WAUKESHA - SS



OLD REPUBLIC SURETY COMPANY
[Signature]

President

On this 19TH day of MAY, 2010, personally came before me, GERALD C. LEACH and RICK A. JOHNSON to me known to be the individuals and officers of the OLD REPUBLIC SURETY COMPANY who executed the above instrument; and they each acknowledged the execution of the same, and being by me duly sworn, did severally depose and say; that they are said officers of the corporation aforesaid, and that the seal affixed to the above instrument is the seal of the corporation, and that said corporate seal and their signatures as such officers were duly affixed and subscribed to the said instrument by the authority of the board of directors of said corporation.



[Signature]

Notary Public
My commission expires: 12/02/2012

CERTIFICATE

I, the undersigned, assistant secretary of the OLD REPUBLIC SURETY COMPANY, a Wisconsin corporation, CERTIFY that the foregoing and attached Power of Attorney remains in full force and has not been revoked; and furthermore, that the Resolutions of the board of directors set forth in the Power of Attorney, are now in force.

27-0200
Signed and sealed at the City of Brookfield, WI this 20th day of January 2011
[Signature]

Assistant Secretary



WELLS FARGO INS SVCS OF WV INC

State of West Virginia

VENDOR PREFERENCE CERTIFICATE

Certification and application* is hereby made for Preference in accordance with *West Virginia Code*, §5A-3-37. (Does not apply to construction contracts). *West Virginia Code*, §5A-3-37, provides an opportunity for qualifying vendors to request (at the time of bid) preference for their residency status. Such preference is an evaluation method only and will be applied only to the cost bid in accordance with the *West Virginia Code*. This certificate for application is to be used to request such preference. The Purchasing Division will make the determination of the Resident Vendor Preference, if applicable.

1. **Application is made for 2.5% resident vendor preference for the reason checked:**
 Bidder is an individual resident vendor and has resided continuously in West Virginia for four (4) years immediately preceding the date of this certification; or,
 Bidder is a partnership, association or corporation resident vendor and has maintained its headquarters or principal place of business continuously in West Virginia for four (4) years immediately preceding the date of this certification; or 80% of the ownership interest of Bidder is held by another individual, partnership, association or corporation resident vendor who has maintained its headquarters or principal place of business continuously in West Virginia for four (4) years immediately preceding the date of this certification; or,
 Bidder is a nonresident vendor which has an affiliate or subsidiary which employs a minimum of one hundred state residents and which has maintained its headquarters or principal place of business within West Virginia continuously for the four (4) years immediately preceding the date of this certification; or,
2. **Application is made for 2.5% resident vendor preference for the reason checked:**
 Bidder is a resident vendor who certifies that, during the life of the contract, on average at least 75% of the employees working on the project being bid are residents of West Virginia who have resided in the state continuously for the two years immediately preceding submission of this bid; or,
3. **Application is made for 2.5% resident vendor preference for the reason checked:**
 Bidder is a nonresident vendor employing a minimum of one hundred state residents or is a nonresident vendor with an affiliate or subsidiary which maintains its headquarters or principal place of business within West Virginia employing a minimum of one hundred state residents who certifies that, during the life of the contract, on average at least 75% of the employees or Bidder's affiliate's or subsidiary's employees are residents of West Virginia who have resided in the state continuously for the two years immediately preceding submission of this bid; or,
4. **Application is made for 5% resident vendor preference for the reason checked:**
 Bidder meets either the requirement of both subdivisions (1) and (2) or subdivision (1) and (3) as stated above; or,
5. **Application is made for 3.5% resident vendor preference who is a veteran for the reason checked:**
 Bidder is an individual resident vendor who is a veteran of the United States armed forces, the reserves or the National Guard and has resided in West Virginia continuously for the four years immediately preceding the date on which the bid is submitted; or,
6. **Application is made for 3.5% resident vendor preference who is a veteran for the reason checked:**
 Bidder is a resident vendor who is a veteran of the United States armed forces, the reserves or the National Guard, if, for purposes of producing or distributing the commodities or completing the project which is the subject of the vendor's bid and continuously over the entire term of the project, on average at least seventy-five percent of the vendor's employees are residents of West Virginia who have resided in the state continuously for the two immediately preceding years.

Bidder understands if the Secretary of Revenue determines that a Bidder receiving preference has failed to continue to meet the requirements for such preference, the Secretary may order the Director of Purchasing to: (a) reject the bid; or (b) assess a penalty against such Bidder in an amount not to exceed 5% of the bid amount and that such penalty will be paid to the contracting agency or deducted from any unpaid balance on the contract or purchase order.

By submission of this certificate, Bidder agrees to disclose any reasonably requested information to the Purchasing Division and authorizes the Department of Revenue to disclose to the Director of Purchasing appropriate information verifying that Bidder has paid the required business taxes, provided that such information does not contain the amounts of taxes paid nor any other information deemed by the Tax Commissioner to be confidential.

Under penalty of law for false swearing (*West Virginia Code*, §61-5-3), Bidder hereby certifies that this certificate is true and accurate in all respects; and that if a contract is issued to Bidder and if anything contained within this certificate changes during the term of the contract, Bidder will notify the Purchasing Division in writing immediately.

Bidder: Hickman Electric Corp Signed: Rocky Hahn
 Date: 1-18-11 Title: President

*Check any combination of preference consideration(s) indicated above, which you are entitled to receive.

RFQ No. ISCL0048

STATE OF WEST VIRGINIA
Purchasing Division
PURCHASING AFFIDAVIT

West Virginia Code §5A-3-10a states: No contract or renewal of any contract may be awarded by the state or any of its political subdivisions to any vendor or prospective vendor when the vendor or prospective vendor or a related party to the vendor or prospective vendor is a debtor and the debt owed is an amount greater than one thousand dollars in the aggregate.

DEFINITIONS:

"Debt" means any assessment, premium, penalty, fine, tax or other amount of money owed to the state or any of its political subdivisions because of a judgment, fine, permit violation, license assessment, defaulted workers' compensation premium, penalty or other assessment presently delinquent or due and required to be paid to the state or any of its political subdivisions, including any interest or additional penalties accrued thereon.

"Debtor" means any individual, corporation, partnership, association, limited liability company or any other form or business association owing a debt to the state or any of its political subdivisions. "Political subdivision" means any county commission, municipality, county board of education, any instrumentality established by a county or municipality, any separate corporation or instrumentality established by one or more counties or municipalities, as permitted by law, or any public body charged by law with the performance of a government function or whose jurisdiction is coextensive with one or more counties or municipalities. "Related party" means a party, whether an individual, corporation, partnership, association, limited liability company or any other form or business association or other entity whatsoever, related to any vendor by blood, marriage, ownership or contract through which the party has a relationship of ownership or other interest with the vendor so that the party will actually or by effect receive or control a portion of the benefit, profit or other consideration from performance of a vendor contract with the party receiving an amount that meets or exceeds five percent of the total contract amount.

EXCEPTION: The prohibition of this section does not apply where a vendor has contested any tax administered pursuant to chapter eleven of this code, workers' compensation premium, permit fee or environmental fee or assessment and the matter has not become final or where the vendor has entered into a payment plan or agreement and the vendor is not in default of any of the provisions of such plan or agreement.

Under penalty of law for false swearing (*West Virginia Code §61-5-3*), it is hereby certified that the vendor affirms and acknowledges the information in this affidavit and is in compliance with the requirements as stated.

WITNESS THE FOLLOWING SIGNATURE

Vendor's Name: Hickman Electric Corp

Authorized Signature: [Signature] Date: 1-19-11

State of W. Va.

County of BRAXTON, to-wit:

Taken, subscribed, and sworn to before me this 19th day of January, 2011.

My Commission expires Oct. 25, 2014.

AFFIX SEAL HERE



Place Seal:
Notary Public, State of West Virginia
Kathryn A. Uldrich
136 Lee Street
Gassaway, WV 26624
My commission expires: October 25, 2014

NOTARY PUBLIC

[Signature]