



State of West Virginia  
 Department of Administration  
 Purchasing Division  
 2019 Washington Street East  
 Post Office Box 50130  
 Charleston, WV 25305-0130

# Request for Quotation

RFQ NUMBER  
 GSD116457

PAGE  
 1

ADDRESS CORRESPONDENCE TO ATTENTION OF  
 KRISTA FERRELL  
 304-558-2596

RFQ COPY  
 TYPE NAME/ADDRESS HERE

Danhill Construction Company  
 PO Box 685  
 Gauley Bridge, WV 25085

DEPARTMENT OF ADMINISTRATION  
 GENERAL SERVICES DIVISION  
 JOBSITE  
 SEE SPECIFICATIONS

304-558-2317

DATE PRINTED	TERMS OF SALE	SHIP VIA	FOB	FREIGHT TERMS
05/26/2011				
BID OPENING DATE: 06/30/2011		BID OPENING TIME 01:30PM		

LINE	QUANTITY	UOP	CAT. NO.	ITEM NUMBER	UNIT PRICE	AMOUNT
0001	1	LS		968-42		\$ 258,900.00
CAPITOL CAMPUS CONCRETE REPAIRS  REQUEST FOR QUOTATION (RFQ) CONSTRUCTION  THE WEST VIRGINIA STATE PURCHASING DIVISION FOR THE AGENCY, THE WEST VIRGINIA DIVISION OF GENERAL SERVICES, IS SOLICITING BIDS TO PROVIDE THE AGENCY WITH ALL LABOR AND MATERIALS FOR THE REPAIR AND REPLACEMENT OF SIDEWALKS LOCATED ON THE WEST VIRGINIA STATE CAPITOL COMPLEX IN CHARLESTON, WEST VIRGINIA PER THE ATTACHED SPECIFICATIONS.  A MANDATORY PRE-BID MEETING WILL BE HELD ON 06/07/2011 AT 10:00 AM IN BLDG 1 (MAIN CAPITOL) IN RM MB60 LOCATED ON THE WV STATE CAPITOL COMPLEX IN CHARLESTON, WV. ALL INTERESTED PARTIES ARE REQUIRED TO ATTEND THIS MEETING FAILURE TO ATTEND THE MANDATORY PRE-BID SHALL RESULT IN DISQUALIFICATION OF THE BID. NO ONE PERSON MAY REPRESENT MORE THAN ONE BIDDER.  AN ATTENDANCE SHEET WILL BE MADE AVAILABLE FOR ALL POTENTIAL BIDDERS TO COMPLETE. THIS WILL SERVE AS THE OFFICIAL DOCUMENT VERIFYING ATTENDANCE AT THE MANDATORY PRE-BID. FAILURE TO PROVIDE YOUR COMPANY AND REPRESENTATIVE NAME ON THE ATTENDANCE SHEET WILL RESULT IN DISQUALIFICATION OF THE BID. THE STATE WILL NOT ACCEPT ANY OTHER DOCUMENTATION TO VERIFY ATTENDANCE. THE BIDDER IS RESPONSIBLE FOR ENSURING THEY HAVE						

*Two Hundred Fifty Eight Thousand Nine Hundred.*

RECEIVED

2011 JUN 30 P 12:43

DEPARTMENT OF ADMINISTRATION  
 GENERAL SERVICES DIVISION  
 CHARLESTON, WV

SEE REVERSE SIDE FOR TERMS AND CONDITIONS

SIGNATURE: *Robert D. Hill* TELEPHONE: 632-1600 DATE: 6/30/2011  
 TITLE: President FERN: 55-0648251 ADDRESS CHANGES TO BE NOTED ABOVE

WHEN RESPONDING TO RFQ, INSERT NAME AND ADDRESS IN SPACE ABOVE LABELED 'VENDOR'

**GENERAL TERMS & CONDITIONS**  
**REQUEST FOR QUOTATION (RFQ) AND REQUEST FOR PROPOSAL (RFP)**

1. Awards will be made in the best interest of the State of West Virginia.
2. The State may accept or reject in part, or in whole, any bid.
3. Prior to any award, the apparent successful vendor must be properly registered with the Purchasing Division and have paid the required \$125 fee.
4. All services performed or goods delivered under State Purchase Order/Contracts are to be continued for the term of the Purchase Order/Contracts, contingent upon funds being appropriated by the Legislature or otherwise being made available. In the event funds are not appropriated or otherwise available for these services or goods this Purchase Order/Contract becomes void and of no effect after June 30.
5. Payment may only be made after the delivery and acceptance of goods or services.
6. Interest may be paid for late payment in accordance with the *West Virginia Code*.
7. Vendor preference will be granted upon written request in accordance with the *West Virginia Code*.
8. The State of West Virginia is exempt from federal and state taxes and will not pay or reimburse such taxes.
9. The Director of Purchasing may cancel any Purchase Order/Contract upon 30 days written notice to the seller.
10. The laws of the State of West Virginia and the *Legislative Rules* of the Purchasing Division shall govern the purchasing process.
11. Any reference to automatic renewal is hereby deleted. The Contract may be renewed only upon mutual written agreement of the parties.
12. **BANKRUPTCY:** In the event the vendor/contractor files for bankruptcy protection, the State may deem this contract null and void, and terminate such contract without further order.
13. **HIPAA BUSINESS ASSOCIATE ADDENDUM:** The West Virginia State Government HIPAA Business Associate Addendum (BAA), approved by the Attorney General, is available online at [www.state.wv.us/admin/purchase/vrc/hipaa.htm](http://www.state.wv.us/admin/purchase/vrc/hipaa.htm) and is hereby made part of the agreement. Provided that the Agency meets the definition of a Cover Entity (45 CFR §160.103) and will be disclosing Protected Health Information (45 CFR §160.103) to the vendor.
14. **CONFIDENTIALITY:** The vendor agrees that he or she will not disclose to anyone, directly or indirectly, any such personally identifiable information or other confidential information gained from the agency, unless the individual who is the subject of the information consents to the disclosure in writing or the disclosure is made pursuant to the agency's policies, procedures, and rules. Vendor further agrees to comply with the Confidentiality Policies and Information Security Accountability Requirements, set forth in <http://www.state.wv.us/admin/purchase/privacy/noticeConfidentiality.pdf>.
15. **LICENSING:** Vendors must be licensed and in good standing in accordance with any and all state and local laws and requirements by any state or local agency of West Virginia, including, but not limited to, the West Virginia Secretary of State's Office, the West Virginia Tax Department, and the West Virginia Insurance Commission. The vendor must provide all necessary releases to obtain information to enable the director or spending unit to verify that the vendor is licensed and in good standing with the above entities.
16. **ANTITRUST:** In submitting a bid to any agency for the State of West Virginia, the bidder offers and agrees that if the bid is accepted the bidder will convey, sell, assign or transfer to the State of West Virginia all rights, title and interest in and to all causes of action it may now or hereafter acquire under the antitrust laws of the United States and the State of West Virginia for price fixing and/or unreasonable restraints of trade relating to the particular commodities or services purchased or acquired by the State of West Virginia. Such assignment shall be made and become effective at the time the purchasing agency tenders the initial payment to the bidder.

I certify that this bid is made without prior understanding, agreement, or connection with any corporation, firm, limited liability company, partnership, or person or entity submitting a bid for the same material, supplies, equipment or services and is in all respects fair and without collusion or fraud. I further certify that I am authorized to sign the certification on behalf of the bidder or this bid.

**INSTRUCTIONS TO BIDDERS**

1. Use the quotation forms provided by the Purchasing Division. Complete all sections of the quotation form.
2. Items offered must be in compliance with the specifications. Any deviation from the specifications must be clearly indicated by the bidder. Alternates offered by the bidder as **EQUAL** to the specifications must be clearly defined. A bidder offering an alternate should attach complete specifications and literature to the bid. The Purchasing Division may waive minor deviations to specifications.
3. Unit prices shall prevail in case of discrepancy. All quotations are considered F.O.B. destination unless alternate shipping terms are clearly identified in the quotation.
4. All quotations must be delivered by the bidder to the office listed below prior to the date and time of the bid opening. Failure of the bidder to deliver the quotations on time will result in bid disqualifications: Department of Administration, Purchasing Division, 2019 Washington Street East, P.O. Box 50130, Charleston, WV 25305-0130
5. Communication during the solicitation, bid, evaluation or award periods, except through the Purchasing Division, is strictly prohibited (W.Va. C.S.R. §148-1-6.6).



State of West Virginia  
 Department of Administration  
 Purchasing Division  
 2019 Washington Street East  
 Post Office Box 50130  
 Charleston, WV 25305-0130

# Request for Quotation

RFQ NUMBER  
 GSD116457

PAGE  
 2

ADDRESS CORRESPONDENCE TO ATTENTION OF  
 KRISTA FERRELL  
 304-558-2596

RFQ COPY  
 TYPE NAME/ADDRESS HERE

DEPARTMENT OF ADMINISTRATION  
 GENERAL SERVICES DIVISION  
 JOBSITE  
 SEE SPECIFICATIONS

304-558-2317

DATE PRINTED	TERMS OF SALE	SHIP VIA	FOB	FREIGHT TERMS
05/26/2011				
BID OPENING DATE: 06/30/2011		BID OPENING TIME 01:30PM		

LINE	QUANTITY	UOP	CAT NO	ITEM NUMBER	UNIT PRICE	AMOUNT
<p>COMPLETED THE INFORMATION REQUIRED ON THE ATTENDANCE SHEET. THE PURCHASING DIVISION AND THE STATE AGENCY WILL NOT ASSUME ANY RESPONSIBILITY FOR A BIDDER-S FAILURE TO COMPLETE THE PRE-BID ATTENDANCE SHEET. IN ADDITION, WE REQUEST THAT ALL POTENTIAL BIDDERS INCLUDE THEIR E-MAIL ADDRESS AND FAX NUMBER.</p> <p>ALL POTENTIAL BIDDERS ARE REQUESTED TO ARRIVE PRIOR TO THE STARTING TIME FOR THE PRE-BID. BIDDERS WHO ARRIVE LATE, BUT PRIOR TO THE DISMISSAL OF THE TECHNICAL PORTION OF THE PRE-BID WILL BE PERMITTED TO SIGN IN. BIDDERS WHO ARRIVE AFTER CONCLUSION OF THE TECHNICAL PORTION OF THE PRE-BID, BUT DURING ANY SUBSEQUENT PART OF THE PRE-BID WILL NOT BE PERMITTED TO SIGN THE ATTENDANCE SHEET.</p> <p>TECHNICAL QUESTIONS CONCERNING THIS SOLICITATION MUST BE SUBMITTED IN WRITING TO KRISTA FERRELL IN THE WEST VIRGINIA STATE PURCHASING DIVISION VIA FAX AT 304-558-4115 OR VIA EMAIL AT KRISTA.S.FERRELL@WV.GOV.</p> <p>DEADLINE FOR ALL TECHNICAL QUESTION IS 06/14/2011 AT THE CLOSE OF BUSINESS.</p> <p>ALL TECHNICAL QUESTIONS RECEIVED WILL BE ANSWERED BY FORMAL WRITTEN ADDENDUM NOT BE ISSUED BY THE PURCHASING DIVISION AFTER THE DEADLINE HAS LAPSED.</p> <p>VERBAL COMMUNICATION: ANY VERBAL COMMUNICATION BETWEEN ANY STATE PERSONNEL AND THE VENDOR IS NOT BINDING, INCLUDING THAT MADE AT THE MANDATORY PRE-BID MEETING. ONLY INFORMATION ISSUED IN WRITING AND ADDED TO THE SPECIFICATIONS BY FORMAL WRITTEN ADDENDUM IS BINDING.</p> <p>NO CONTACT BETWEEN THE VENDOR AND THE AGENCY IS PERMITTED WITHOUT THE EXPRESS WRITTEN CONSENT OF THE</p>						

SEE REVERSE SIDE FOR TERMS AND CONDITIONS

SIGNATURE	TELEPHONE	DATE
TITLE	FEIN	ADDRESS CHANGES TO BE NOTED ABOVE

WHEN RESPONDING TO RFQ, INSERT NAME AND ADDRESS IN SPACE ABOVE LABELED 'VENDOR'



State of West Virginia  
 Department of Administration  
 Purchasing Division  
 2019 Washington Street East  
 Post Office Box 50130  
 Charleston, WV 25305-0130

# Request for Quotation

RFQ NUMBER  
 GSD116457

PAGE  
 3

ADDRESS CORRESPONDENCE TO ATTENTION OF  
 KRISTA FERRELL  
 304-558-2596

RFQ COPY  
 TYPE NAME/ADDRESS HERE

SHIP TO

DEPARTMENT OF ADMINISTRATION  
 GENERAL SERVICES DIVISION  
 JOBSITE  
 SEE SPECIFICATIONS

304-558-2317

DATE PRINTED	TERMS OF SALE	SHIP VIA	FOB	FREIGHT TERMS
05/26/2011				
BID OPENING DATE: 06/30/2011				

LINE	QUANTITY	UQP	CAT NO	ITEM NUMBER	UNIT PRICE	AMOUNT
------	----------	-----	--------	-------------	------------	--------

STATE BUYER. VIOLATION MAY RESULT IN THE REJECTION OF THE BID. THE STATE BUYER NAMED ABOVE IS THE SOLE CONTACT FOR ANY AND ALL INQUIRIES AFTER THIS RFQ HAS BEEN RELEASED.

THE MODEL/BRAND/SPECIFICATIONS NAMED HEREIN ESTABLISH THE ACCEPTABLE LEVEL OF QUALITY ONLY AND ARE NOT INTENDED TO REFLECT A PREFERENCE OR FAVOR ANY PARTICULAR BRAND OR VENDOR. VENDORS WHO ARE BIDDING ALTERNATES SHOULD SO STATE AND INCLUDE PERTINENT LITERATURE AND SPECIFICATIONS. FAILURE TO PROVIDE INFORMATION FOR ANY ALTERNATES MAY BE GROUNDS FOR REJECTION OF THE BID. THE STATE RESERVES THE RIGHT TO WAIVE MINOR IRREGULARITIES IN BIDS OR SPECIFICATIONS IN ACCORDANCE WITH SECTION 148-1-4(F) OF THE WEST VIRGINIA LEGISLATIVE RULES AND REGULATIONS.

**EXHIBIT 5**

WEST VIRGINIA CODE 21-1D-5 PROVIDES THAT: ANY SOLICITATION FOR A PUBLIC IMPROVEMENT CONSTRUCTION CONTRACT REQUIRES EACH VENDOR THAT SUBMITS A BID FOR THE WORK TO SUBMIT AT THE SAME TIME AN AFFIDAVIT OF COMPLIANCE WITH THE BID. THE ENCLOSED DRUG-FREE WORKPLACE AFFIDAVIT MUST BE SIGNED AND SUBMITTED WITH THE BID AS EVIDENCE OF THE VENDOR'S COMPLIANCE WITH THE PROVISIONS OF ARTICLE 1D, CHAPTER 21 OF THE WEST VIRGINIA CODE. FAILURE TO SUBMIT THE SIGNED DRUG-FREE WORKPLACE AFFIDAVIT WITH THE BID SHALL RESULT IN DISQUALIFICATION OF SUCH BID.

NOTICE TO PROCEED: THIS CONTRACT IS TO BE PERFORMED WITHIN 60 CALENDAR DAYS AFTER THE NOTICE TO PROCEED IS RECEIVED. UNLESS OTHERWISE SPECIFIED, THE FULLY EXECUTED PURCHASE ORDER WILL BE CONSIDERED NOTICE TO PROCEED.

SEE REVERSE SIDE FOR TERMS AND CONDITIONS

SIGNATURE	TELEPHONE	DATE
TITLE	FEIN	ADDRESS CHANGES TO BE NOTED ABOVE

WHEN RESPONDING TO RFQ, INSERT NAME AND ADDRESS IN SPACE ABOVE LABELED 'VENDOR'



State of West Virginia  
 Department of Administration  
 Purchasing Division  
 2019 Washington Street East  
 Post Office Box 50130  
 Charleston, WV 25305-0130

# Request for Quotation

RFQ NUMBER  
**GSD116457**

PAGE  
**4**

ADDRESS CORRESPONDENCE TO ATTENTION OF  
**KRISTA FERRELL  
 304-558-2596**

RFQ COPY  
 TYPE NAME/ADDRESS HERE

VENDOR

SHIP TO

DEPARTMENT OF ADMINISTRATION  
 GENERAL SERVICES DIVISION  
 JOBSITE  
 SEE SPECIFICATIONS

304-558-2317

DATE PRINTED	TERMS OF SALE	SHIP VIA	F.O.B.	FREIGHT TERMS
05/26/2011				
BID OPENING DATE: 06/30/2011		BID OPENING TIME 01:30PM		

LINE	QUANTITY	UQP	CAT. NO.	ITEM NUMBER	UNIT PRICE	AMOUNT
<p><b>CANCELLATION:</b> THE DIRECTOR OF PURCHASING RESERVES THE RIGHT TO CANCEL THIS CONTRACT IMMEDIATELY UPON WRITTEN NOTICE TO THE VENDOR IF THE MATERIALS OR WORKMANSHIP SUPPLIED ARE OF AN INFERIOR QUALITY OR DO NOT CONFORM WITH THE SPECIFICATIONS OF THE BID AND CONTRACT HERE IN.</p> <p><b>WAGE RATES:</b> THE CONTRACTOR OR SUBCONTRACTOR SHALL PAY THE HIGHER OF THE U.S. DEPARTMENT OF LABOR MINIMUM WAGE RATES AS ESTABLISHED FOR KANAWHA COUNTY, PURSUANT TO WEST VIRGINIA CODE 21-5A, ET, SEQ. (PREVAILING WAGE RATES APPLY TO THIS PROJECT)</p> <p><b>ARBITRATION:</b> ANY REFERENCES MADE TO ARBITRATION OR INTEREST FOR PAYMENTS DUE (EXCEPT FOR ANY INTEREST REQUIRED BY STATE LAW) CONTAINED IN THIS CONTRACT OR IN ANY AMERICAN INSTITUTE OF ARCHITECTS DOCUMENTS PERTAINING TO THIS CONTRACT ARE HEREBY DELETED.</p> <p><b>WORKERS' COMPENSATION:</b> VENDOR IS REQUIRED TO PROVIDE A CERTIFICATE FROM WORKERS' COMPENSATION IF SUCCESSFUL.</p> <p>ALL OF THE ITEMS CHECKED BELOW WILL BE A REQUIREMENT OF THIS CONTRACT:</p> <p><input checked="" type="checkbox"/> <b>INSURANCE:</b> SUCCESSFUL VENDOR SHALL FURNISH PROOF OF COMMERCIAL GENERAL LIABILITY INSURANCE PRIOR TO ISSUANCE OF CONTRACT. UNLESS OTHERWISE SPECIFIED IN THE BID DOCUMENTS, THE MINIMUM AMOUNT OF INSURANCE COVERAGE REQUIRED IS \$1,000,000.00.</p> <p><input type="checkbox"/> <b>BUILDERS RISK INSURANCE:</b> SUCCESSFUL VENDOR SHALL FURNISH PROOF OF BUILDERS RISK - ALL RISK INSURANCE IN AN AMOUNT EQUAL TO 100% OF THE AMOUNT OF THE CONTRACT.</p> <p><input checked="" type="checkbox"/> <b>BONDS:</b> FIVE PERCENT (5%) OF THE TOTAL AMOUNT OF</p>						

SEE REVERSE SIDE FOR TERMS AND CONDITIONS

SIGNATURE	TELEPHONE	DATE
TITLE	FEIN	ADDRESS CHANGES TO BE NOTED ABOVE

WHEN RESPONDING TO RFQ, INSERT NAME AND ADDRESS IN SPACE ABOVE LABELED 'VENDOR'



State of West Virginia  
 Department of Administration  
 Purchasing Division  
 2019 Washington Street East  
 Post Office Box 50130  
 Charleston, WV 25305-0130

# Request for Quotation

RFQ NUMBER  
 GSD116457

PAGE  
 5

ADDRESS CORRESPONDENCE TO ATTENTION OF  
 KRISTA FERRELL  
 304-558-2596

RFQ COPY  
 TYPE NAME/ADDRESS HERE

DEPARTMENT OF ADMINISTRATION  
 GENERAL SERVICES DIVISION  
 JOBSITE  
 SEE SPECIFICATIONS

304-558-2317

DATE PRINTED	TERMS OF SALE	SHIP VIA	FOB	FREIGHT TERMS
05/26/2011				
BID OPENING DATE: 06/30/2011		BID OPENING TIME 01:30PM		

LINE	QUANTITY	UOP	CAT NO	ITEM NUMBER	UNIT PRICE	AMOUNT
<p>THE BID PAYABLE TO THE STATE OF WEST VIRGINIA, SHALL BE SUBMITTED WITH EACH BID AS A BID BOND. THE SUCCESSFUL BIDDER SHALL ALSO FURNISH A PERFORMANCE BOND AND LABOR/MATERIAL BOND FOR 100% OF THE AMOUNT OF THE CONTRACT. BONDS MAY BE PROVIDED IN THE FORM OF A CERTIFIED CHECK, IRREVOCABLE LETTER OF CREDIT, OR BOND FURNISHED BY A SOLVENT SURETY COMPANY AUTHORIZED TO DO BUSINESS IN THE STATE OF WEST VIRGINIA. A LETTER OF CREDIT SUBMITTED IN LIEU OF A BOND WILL ONLY BE ALLOWED FOR PROJECTS UNDER \$100,000. PERSONAL OR BUSINESS CHECKS ARE NOT ACCEPCTABLE IN LIEU OF THE 5% BID BOND, PERFORMANCE BOND, OR LABOR AND MATERIAL BOND.</p> <p>( ) MAINTENANCE BOND: A TWO (2) YEAR MAINTENANCE BOND COVERING THE ROOFING SYSTEM WILL BE A REQUIREMENT OF THE SUCCESSFUL VENDOR.</p> <p>REV. 11/00</p> <p>EXHIBIT 7</p> <p>DOMESTIC ALUMINUM, GLASS &amp; STEEL IN PUBLIC WORKS PROJECTS</p> <p>IN ACCORDANCE WITH WEST VIRGINIA CODE 5-19-1 ET., SEQ., EVERY CONTRACT FOR CONSTRUCTION, RECONSTRUCTION, ALTERATION, REPAIR, IMPROVEMENT OR MAINTENANCE OF PUBLIC WORKS, WHERE THE COST IS MORE THAN \$50,000 AND, IN THE CASE OF STEEL ONLY, WHERE THE COST OF STEEL IS MORE THAN \$50,000 OR WHERE MORE THAN 10,000 POUNDS OF STEEL ARE REQUIRED, THE STATE WILL ACCEPT ONLY ALUMINUM GLASS, OR STEEL PRODUCTS PRODUCED IN THE UNITED STATES. IN ADDITION, ITEMS OF MACHINERY OR EQUIPMENT PURCHASED FOR USE AT THE SITE OF PUBLIC WORKS SHALL BE MADE OF DOMESTIC ALUMINUM, GLASS OR STEEL, UNLESS THE COST OF</p>						

SEE REVERSE SIDE FOR TERMS AND CONDITIONS

SIGNATURE	TELEPHONE	DATE
TITLE	FERN	ADDRESS CHANGES TO BE NOTED ABOVE

WHEN RESPONDING TO RFQ, INSERT NAME AND ADDRESS IN SPACE ABOVE LABELED 'VENDOR'



State of West Virginia  
 Department of Administration  
 Purchasing Division  
 2019 Washington Street East  
 Post Office Box 50130  
 Charleston, WV 25305-0130

# Request for Quotation

RFQ NUMBER
GSD116457

PAGE
6

ADDRESS CORRESPONDENCE TO ATTENTION OF
KRISTA FERRELL 804-558-2596

VENDOR

RFQ COPY  
 TYPE NAME/ADDRESS HERE

SHIP TO

DEPARTMENT OF ADMINISTRATION  
 GENERAL SERVICES DIVISION  
 JOBSITE  
 SEE SPECIFICATIONS

304-558-2317

DATE PRINTED	TERMS OF SALE	SHIP VIA	FOB	FREIGHT TERMS
05/26/2011				

BID OPENING DATE: 06/30/2011	BID OPENING TIME: 01:30PM
------------------------------	---------------------------

LINE	QUANTITY	UOP	CAT NO.	ITEM NUMBER	UNIT PRICE	AMOUNT
<p>THE PRODUCT IS LESS THAN \$50,000 OR LESS THAN 10,000 POUNDS OF STEEL ARE USED IN PUBLIC WORKS PROJECTS.</p> <p>FOREIGN MADE ALUMINUM, GLASS OR STEEL PRODUCTS MAY BE ACCEPTED ONLY IF THE COST OF DOMESTIC PRODUCTS IS FOUND TO BE UNREASONABLE. SUCH COST IS UNREASONABLE IF IT IS 20% OR MORE HIGHER THAN THE BID PRICE FOR FOREIGN MADE PRODUCTS. IF THE DOMESTIC ALUMINUM, GLASS OR STEEL PRODUCTS TO BE SUPPLIED OR PRODUCED IN A "SUBSTANTIAL LABOR SURPLUS AREA", AS DEFINED BY THE UNITED STATES DEPARTMENT OF LABOR, FOREIGN PRODUCTS MAY BE SUPPLIED ONLY IF DOMESTIC PRODUCTS ARE 30% OR MORE HIGHER IN PRICE THAN THE FOREIGN MADE PRODUCTS.</p> <p>IF, PRIOR TO THE AWARD OF A CONTRACT UNDER THE ABOVE PROVISIONS, THE SPENDING OFFICER OF THE SPENDING UNIT DETERMINES THAT THERE EXISTS A BID FOR LIKE FOREIGN ALUMINUM, GLASS OR STEEL THAT IS REASONABLE AND LOWER THAN THE LOWEST BID DOMESTIC PRODUCTS, THE SPENDING OFFICE MAY REQUEST, IN WRITING, A REEVALUATION AND REDUCTION IN THE LOWEST BID FOR SUCH DOMESTIC PRODUCTS. ALL VENDORS MUST INDICATE IN THEIR BID IF THEY ARE SUPPLYING FOREIGN ALUMINUM, GLASS OR STEEL.</p> <p>REV. 3/88</p> <p>EXHIBIT 9</p> <p>NOTICE FOR ISSUANCE &amp; ACKNOWLEDGEMENT OF CONSTRUCTION PROJECT ADDENDA</p> <p>THE ARCHITECT/ENGINEER AND/OR AGENCY SHALL BE REQUIRED TO ABIDE BY THE FOLLOWING SCHEDULE IN ISSUING CONSTRUCTION PROJECT ADDENDA FOR STATE AGENCIES:</p>						

SEE REVERSE SIDE FOR TERMS AND CONDITIONS

SIGNATURE	TELEPHONE	DATE
TITLE	FEN	ADDRESS CHANGES TO BE NOTED ABOVE

WHEN RESPONDING TO RFQ, INSERT NAME AND ADDRESS IN SPACE ABOVE LABELED 'VENDOR'



State of West Virginia  
 Department of Administration  
 Purchasing Division  
 2019 Washington Street East  
 Post Office Box 50130  
 Charleston, WV 25305-0130

# Request for Quotation

RFQ NUMBER  
 GSD116457

PAGE  
 7

ADDRESS CORRESPONDENCE TO ATTENTION OF  
 KRISTA FERRELL  
 304-558-2596

VENDOR

RFQ COPY  
 TYPE NAME/ADDRESS HERE

SHIP TO

DEPARTMENT OF ADMINISTRATION  
 GENERAL SERVICES DIVISION  
 JOBSITE  
 SEE SPECIFICATIONS

304-558-2317

DATE PRINTED	TERMS OF SALE	SHIP VIA	POB	FREIGHT TERMS
05/26/2011				

BID OPENING DATE: 06/30/2011 BID OPENING TIME 01:30PM

LINE	QUANTITY	UQP	CAT NO	ITEM NUMBER	UNIT PRICE	AMOUNT
<p>(1) THE ARCHITECT/ENGINEER SHALL PREPARE THE ADDENDUM AND A LIST OF ALL PARTIES THAT HAVE PROCURED DRAWINGS AND SPECIFICATIONS FOR THE PROJECT. THE ADDENDUM AND LIST SHALL BE FORWARDED TO THE BUYER IN THE STATE PURCHASING DIVISION. THE ARCHITECT/ENGINEER SHALL ALSO SEND A COPY OF THE ADDENDUM TO THE STATE AGENCY FOR WHICH THE CONTRACT IS ISSUED.</p> <p>(2) THE BUYER SHALL SEND THE ADDENDUM TO ALL INTERESTED PARTIES AND, IF NECESSARY, EXTEND THE BID OPENING DATE. ANY ADDENDUM SHOULD BE RECEIVED BY THE BUYER WITHIN FOURTEEN (14) DAYS PRIOR TO THE BID OPENING DATE.</p> <p>(3) ALL ADDENDA SHOULD BE FORMALLY ACKNOWLEDGED BY ALL BIDDERS AND SUBMITTED TO THE STATE PURCHASING DIVISION. THE SAME RULES AND REGULATIONS THAT APPLY TO THE ORIGINAL BIDDING DOCUMENT SHALL ALSO APPLY TO AN ADDENDUM DOCUMENT. THE ONLY EXCEPTION MAY BE FOR AN ADDENDUM THAT IS ISSUED FOR THE SOLE PURPOSE OF CHANGING A BID OPENING TIME AND/OR DATE.</p> <p>REV. 11/96</p> <p>EXHIBIT 10</p> <p>ADDENDUM ACKNOWLEDGEMENT</p> <p>I HEREBY ACKNOWLEDGE RECEIPT OF THE FOLLOWING CHECKED ADDENDUM(S) AND HAVE MADE THE NECESSARY REVISIONS TO MY PROPOSAL, PLANS AND/OR SPECIFICATION, ETC.</p> <p>ADDENDUM NOS. :</p>						

SEE REVERSE SIDE FOR TERMS AND CONDITIONS

SIGNATURE \_\_\_\_\_ TELEPHONE \_\_\_\_\_ DATE \_\_\_\_\_

TITLE \_\_\_\_\_ FEIN \_\_\_\_\_ ADDRESS CHANGES TO BE NOTED ABOVE

WHEN RESPONDING TO RFQ, INSERT NAME AND ADDRESS IN SPACE ABOVE LABELED 'VENDOR'





State of West Virginia  
 Department of Administration  
 Purchasing Division  
 2019 Washington Street East  
 Post Office Box 50130  
 Charleston, WV 25305-0130

# Request for Quotation

RFQ NUMBER  
**GSD116457**

PAGE  
**8**

ADDRESS CORRESPONDENCE TO ATTENTION OF  
**KRISTA FERRELL  
 304-558-2596**

RFQ COPY  
 TYPE NAME/ADDRESS HERE

Danhill Construction Company  
 PO Box 685  
 Gauley Bridge, WV 25085

DEPARTMENT OF ADMINISTRATION  
 GENERAL SERVICES DIVISION  
 JOBSITE  
 SEE SPECIFICATIONS

304-558-2317

DATE PRINTED	TERMS OF SALE	SHIP VIA	FOB	FREIGHT TERMS
05/26/2011				
BID OPENING DATE: 06/30/2011		BID OPENING TIME: 01:30PM		

LINE	QUANTITY	UOP	CAT NO	ITEM NUMBER	UNIT PRICE	AMOUNT
------	----------	-----	--------	-------------	------------	--------

NO. 1 ..... 6/16/2011  
 NO. 2 .....  
 NO. 3 .....  
 NO. 4 .....  
 NO. 5 .....

I UNDERSTAND THAT FAILURE TO CONFIRM THE RECEIPT OF THE ADDENDUM(S) MAY BE CAUSE FOR REJECTION OF THE BIDS.

VENDOR MUST CLEARLY UNDERSTAND THAT ANY VERBAL REPRESENTATION MADE OR ASSUMED TO BE MADE DURING ANY ORAL DISCUSSION HELD BETWEEN VENDOR'S REPRESENTATIVES AND ANY STATE PERSONNEL IS NOT BINDING. ONLY THE INFORMATION ISSUED IN WRITING AND ADDED TO THE SPECIFICATIONS BY AN OFFICIAL ADDENDUM IS BINDING.

*Robert D. Hill* ..... SIGNATURE  
*Danhill Construction* ..... COMPANY  
*6/30/2011* ..... DATE

REV. 11/96

CONTRACTORS LICENSE

WEST VIRGINIA STATE CODE 21-11-2 REQUIRES THAT ALL PERSONS DESIRING TO PERFORM CONTRACTING WORK IN THIS STATE MUST BE LICENSED. THE WEST VIRGINIA CONTRACTORS LICENSING BOARD IS EMPOWERED TO ISSUE THE CONTRACTORS

SIGNATURE <i>Robert D. Hill</i>		TELEPHONE <i>632-1600</i>	DATE <i>6/30/2011</i>
TITLE <i>President</i>	FEN <i>SS-0648251</i>	ADDRESS CHANGES TO BE NOTED ABOVE	

WHEN RESPONDING TO RFQ, INSERT NAME AND ADDRESS IN SPACE ABOVE LABELED 'VENDOR'



State of West Virginia  
 Department of Administration  
 Purchasing Division  
 2019 Washington Street East  
 Post Office Box 50130  
 Charleston, WV 25305-0130

# Request for Quotation

RFQ NUMBER  
 GSD116457

PAGE  
 9

ADDRESS CORRESPONDENCE TO ATTENTION OF  
 KRISTA FERRELL  
 304-558-2596

RFQ COPY  
 TYPE NAME/ADDRESS HERE

VENDOR

Danhill Construction Company  
 PO Box 685  
 Gauley Bridge, WV 25085

SHIP TO

DEPARTMENT OF ADMINISTRATION  
 GENERAL SERVICES DIVISION  
 JOBSITE  
 SEE SPECIFICATIONS

304-558-2317

DATE PRINTED	TERMS OF SALE	SHIP VIA	FOB	FREIGHT TERMS
05/26/2011				
BID OPENING DATE: 06/30/2011		BID OPENING TIME 01:30PM		

LINE	QUANTITY	UOP	CAT NO	ITEM NUMBER	UNIT PRICE	AMOUNT
<p>LICENSE. APPLICATIONS FOR A CONTRACTORS LICENSE MAY BE MADE BY CONTACTING THE WEST VIRGINIA DIVISION OF LABOR CAPITOL COMPLEX, BUILDING 3, ROOM 319, CHARLESTON, WV 25305. TELEPHONE: (304) 558-7890.</p> <p>WEST VIRGINIA STATE CODE 21-11-11 REQUIRES ANY PROSPECTIVE BIDDER TO INCLUDE THE CONTRACTORS LICENSE NUMBER ON THEIR BID.</p> <p>BIDDER TO COMPLETE:</p> <p>CONTRACTORS NAME: .... <i>Danhill Construction Company</i></p> <p>CONTRACTORS LICENSE NO.: <i>WV001196</i>.....</p> <p>THE SUCCESSFUL BIDDER WILL BE REQUIRED TO FURNISH A COPY OF THEIR CONTRACTORS LICENSE PRIOR TO ISSUANCE OF A PURCHASE ORDER/CONTRACT</p> <p style="text-align: center;">APPLICABLE LAW</p> <p>THE WEST VIRGINIA STATE CODE, PURCHASING DIVISION RULES AND REGULATIONS, AND THE INFORMATION PROVIDED IN THE "REQUEST FOR QUOTATION" ISSUED BY THE PURCHASING DIVISION IS THE SOLE AUTHORITY GOVERNING THIS PROCUREMENT.</p> <p>ANY INFORMATION PROVIDED IN SPECIFICATION MANUALS, OR ANY OTHER SOURCE, VERBAL OR WRITTEN, WHICH CONTRADICTS OR ALTERS THE INFORMATION PROVIDED FROM THE SOURCES AS DESCRIBED IN THE ABOVE PARAGRAPH IS VOID AND OF NO EFFECT.</p> <p>BANKRUPTCY: IN THE EVENT THE VENDOR/CONTRACTOR FILES FOR BANKRUPTCY PROTECTION, THE STATE MAY DEEM THE CONTRACT NULL AND VOID, AND TERMINATE SUCH CONTRACT</p>						

SEE REVERSE SIDE FOR TERMS AND CONDITIONS

SIGNATURE <i>Robert D Hill</i>	TELEPHONE 632-1600	DATE 6/30/2011
TITLE <i>President</i>	FAX 55-0648251	ADDRESS CHANGES TO BE NOTED ABOVE

WHEN RESPONDING TO RFQ, INSERT NAME AND ADDRESS IN SPACE ABOVE LABELED 'VENDOR'

*RDH*



State of West Virginia  
 Department of Administration  
 Purchasing Division  
 2019 Washington Street East  
 Post Office Box 50130  
 Charleston, WV 25305-0130

# Request for Quotation

RFQ NUMBER  
 GSD116457

PAGE  
 10

ADDRESS CORRESPONDENCE TO ATTENTION OF  
 KRISTA FERRELL  
 304-558-2596

RFQ COPY  
 TYPE NAME/ADDRESS HERE

Danhill Construction Company  
 PO Box 685  
 Gauley Bridge, WV 25085

DEPARTMENT OF ADMINISTRATION  
 GENERAL SERVICES DIVISION  
 JOBSITE  
 SEE SPECIFICATIONS

304-558-2317

DATE PRINTED	TERMS OF SALE	SHIP VIA	FOB	FREIGHT TERMS
05/26/2011				

BID OPENING DATE: 06/30/2011 BID OPENING TIME 01:30PM

LINE	QUANTITY	UOP	CAT. NO.	ITEM NUMBER	UNIT PRICE	AMOUNT
WITHOUT FURTHER ORDER. REV. 5/2009  NOTICE A SIGNED BID MUST BE SUBMITTED TO:  DEPARTMENT OF ADMINISTRATION PURCHASING DIVISION BUILDING 15 2019 WASHINGTON STREET, EAST CHARLESTON, WV 25305-0130  THE BID SHOULD CONTAIN THIS INFORMATION ON THE FACE OF THE ENVELOPE OR THE BID MAY NOT BE CONSIDERED:  SEALED BID  BUYER: KRISTA FERRELL-FILE 21 REQ. NO.: GSD116457 BID OPENING DATE: BID OPENING TIME: 1:30 PM  PLEASE PROVIDE A FAX NUMBER IN CASE IT IS NECESSARY TO CONTACT YOU REGARDING YOUR BID: ----- 304 632-1501 -----  PLEASE PRINT OR TYPE NAME OF PERSON TO CONTACT CONCERNING THIS QUOTE:						

SEE REVERSE SIDE FOR TERMS AND CONDITIONS

SIGNATURE <i>Robert D Hill</i>	TELEPHONE 632-1600	DATE 6/30/2011
TITLE President	FAX 55-0648251	ADDRESS CHANGES TO BE NOTED ABOVE

WHEN RESPONDING TO RFQ, INSERT NAME AND ADDRESS IN SPACE ABOVE LABELED 'VENDOR'



State of West Virginia  
 Department of Administration  
 Purchasing Division  
 2019 Washington Street East  
 Post Office Box 50130  
 Charleston, WV 25305-0130

# Request for Quotation

RFQ NUMBER  
 GSD116457

PAGE  
 11

ADDRESS CORRESPONDENCE TO ATTENTION OF  
 KRISTA FERRELL  
 304-558-2596

RFQ COPY

TYPE NAME/ADDRESS HERE

Danhill Construction Company  
 PO Box 685  
 Gauley Bridge, WV 25085

SHIP TO

DEPARTMENT OF ADMINISTRATION  
 GENERAL SERVICES DIVISION  
 JOBSITE  
 SEE SPECIFICATIONS

304-558-2317

DATE PRINTED	TERMS OF SALE	SHIP VIA	F.O.B.	FREIGHT TERMS
05/26/2011				

BID OPENING DATE:

06/30/2011

BID OPENING TIME 01:30PM

LINE	QUANTITY	UQP	CAT NO	ITEM NUMBER	UNIT PRICE	AMOUNT
DAN HILL						
***** THIS IS THE END OF RFQ GSD116457 ***** TOTAL:						\$ 258,900. <sup>00</sup>

SEE REVERSE SIDE FOR TERMS AND CONDITIONS

SIGNATURE <i>Robert D. Hill</i>	TELEPHONE 632-1608	DATE 6/30/2011
TITLE President	FEN 55-0648251	ADDRESS CHANGES TO BE NOTED ABOVE

WHEN RESPONDING TO RFQ, INSERT NAME AND ADDRESS IN SPACE ABOVE LABELED 'VENDOR'

State of West Virginia  
General Services Division

West Virginia State Capitol  
Campus Concrete Repair  
Project GSD116457

**REQUEST FOR QUOTATIONS GSD116457**  
**WEST VIRGINIA STATE CAPITOL COMPLEX**  
**CAMPUS CONCRETE REPAIRS**

Location(s): West Virginia State Capitol Complex  
1900 Kanawha Blvd. East  
Charleston, WV 25305

For: State of West Virginia  
General Services Division  
1900 Kanawha Blvd. East  
Charleston, West Virginia 25305

All inquiries for specification clarification shall be addressed to:

Krista Ferrell, Buyer Supervisor  
Purchasing Division  
P. O. Box 50130  
Charleston, West Virginia 25305-0130  
Telephone: (304) 558-2596  
Fax: (304) 558-4115  
[Krista.S.Ferrell@wv.gov](mailto:Krista.S.Ferrell@wv.gov)

The Acquisition and Contract Administration Section of the Purchasing Division "State" for the West Virginia General Services Division is soliciting quotations to provide concrete sidewalk replacement and repairs, brick step repairs and replace concrete steps with handrails at various points across the State Capitol Complex located at 1900 Kanawha Blvd, East in Charleston, West Virginia. This document is intended to supplement information provided in the standard "Request for Quotation" and "General Terms and Conditions" issued by the Purchasing Division for this project. Vendors should carefully review all documents.

**Pre-Bid Meeting:**

A mandatory pre-bid meeting for this project is scheduled for Tuesday, June 7<sup>th</sup>, 2011 at 10:00 a.m. Contractors attending the meeting shall assemble at Room MB-60 in the Capitol Building basement. See Purchasing Division Request for Quotation for additional information. A walking tour of the project areas will follow the meeting.

**Definitions:**

- A. "Owner", as herein stated, shall mean the Department of Administration, General Services Division, Room MB-60, State Capitol, Charleston, West Virginia.
- B. "Contractor", as herein stated, shall mean the service organization contracted by

State of West Virginia  
General Services Division

West Virginia State Capitol  
Campus Concrete Repair  
Project GSD116457

these specifications.

- C. "The Contract", as herein stated, shall mean the agreement between the Owner and the Contractor to provide the services as herein specified.
- D. "Owners Representative", as herein stated, shall be defined as that person so designated by the Director of the General Services Division.
- E. "Architect/Engineer", as stated in the Contract shall refer to the General Services Division.

**Documents:**

This Request for Quotations also incorporates the attached documents:

1. The WV Purchasing Division "Request for Quotation" and "General Terms and Conditions".
2. GSD116457 Attachment A: Location Map Detail.
3. GSD116457 Attachment B: Curb and Sidewalk Detail
4. GSD116457 Attachment C: Concrete Expansion Joint Detail
5. GSD116457 Attachment D: 03300-Concrete Specification
6. GSD116457 Attachment E: Earthwork Specification
7. GSD116457 Attachment F: Handrail and Step Specification
8. GSD116457 Bid Form

**Scope:**

The work consists of replacing concrete sidewalks, repairing concrete sidewalks and brick steps and walkways and replacing concrete steps with handrails. Work includes, but is not limited to, removing existing concrete and gravel walkways or brick pavers, preparing sub-base, placing gravel base material, placing steel reinforcing mesh or rods, construct expansion joints, pouring, finishing & curing concrete sidewalks and landscape restoration as identified on GSD116457 Attachment A: Location Map Detail. The Contractor shall remove and refurbish brick sidewalks with existing and/or supplemental materials of equal color and quality. The successful Contractor shall be required to keep the work area clean and remove debris from the site daily. Note that building access/exits must be maintained and alternate routes must be provided.

Site work space will be limited however arrangements will be made to provide the successful Contractor a staging area. Parking for Contractor's employees will not be available and must be provided by the Contractor.

Work shall be conducted as a single project and progress in phases by location. Work in each area shall be substantially complete and inspected by the Owner Project Manager prior to beginning the next work area. 72 hours after the issuance of the Notice to Proceed, the Contractor shall submit a schedule showing the replacement sequence, commencement and completion dates for each section of sidewalk. The schedule shall be reviewed and approved by the Owner prior to commencement of the work. Coordinate the schedule around Owner's work requirements.

State of West Virginia  
General Services Division

West Virginia State Capitol  
Campus Concrete Repair  
Project GSD116457

Furnish all materials, labor, and equipment necessary to complete all work as indicated by these specifications. Intent is that the completed work consists of a fully completed sidewalk repair project. Furnish any incidental work, materials, labor and equipment that are necessary to complete the work, even if such incidental work is not explicitly included in the contract documents.

Any equipment contracted for prior to receipt of the signed purchase order and written Notice to Proceed letter shall be at the Bidder's risk.

**Technical Specifications and Drawing Detail:**

**General Notes:**

- Light Broom finish on concrete walkways and steps.
  - All concrete slabs shall be six (6") inches thick and shall have 6x6 - W8xW8 wire mesh on chairs placing the mesh at mid-slab.
  - Sections of concrete areas to be replaced are marked in orange paint and numbered corresponding to the comments below (see Attachment A: Location Map Detail).
  - Area measurements are subject to field verification.
1. Bldg. 6. Northwest steps beside the loading dock: Remove and replace concrete steps and indicated landing, replace handrails, and repair granite wall façade at top of steps. There are 10 steps that are approximately 14' wide.
  2. Bldg. 6. California Avenue mid-entry: Remove and replace concrete steps and landing as indicated. There are approximately 12 steps. Replace all hand rails per specification in Attachment F.
  3. California Avenue, walkway in front of planter and curbing: Remove and replace per the specification in Attachments B for sidewalk and curbing which includes tapering for ADA ramp which may be disturbed. Area is approximately 8ft. x 16ft. Light broom finish.
  4. Culture Center, North Parking Lot side walk and curb: Remove and replace an area of walkway that is approximately 33ft. x 6ft., 1ft. x 35ft. of apron next to grassy area and cut out and replace 2ft. of curbing as marked.
  5. Greenbrier Street, Governor's Drive entrance: Remove and replace approximately 32 ft. of deteriorated curbing as indicated by field marking. Remove and replace deteriorated section of walkway on the North side as indicated by saw cut. The area is approximately 1ft x 8ft. of curbing. Ramps shall be cleaned and repainted in existing color code, curbs shall be repainted existing color.

State of West Virginia  
General Services Division

West Virginia State Capitol  
Campus Concrete Repair  
Project GSD116457

6. Governor's Mansion, Kanawha Blvd., front entrance brick sidewalks and steps: Approximately 350 sq. ft. shall be removed, cleaned and re-laid in existing pattern. Existing material shall be used. Any brick needed to supplement or replace current brick shall be approved in advance by the Owner's Project Manager. Sub-grade shall be compacted and leveled per specifications in Attachments B and E and existing handrails will be reused in current location and counter anchored below grade.
7. East of Bldg. 8, corner of Kanawha Blvd. and the Governor's Walk Path: Contractor shall excavate and pour a 5ft. x 8ft. pad around the lamp post
8. Kanawha Blvd. at Lincoln Plaza: Remove and replace approximately 140ft. of damaged curbing, per specification in Attachment B and repaint.
9. Capitol Southeast sidewalk: Remove and replace the walkway which is approximately 32ft. x 112ft., retain and reinstall brick inserts as indicated on sand base for future excavation. Light broom finish.
10. Capitol North Circle Plaza handicap ramp: Remove and replace, as indicated by orange field marking, a 27ft x 13ft ramp with light broom finish.
11. Sidewalk area(s) adjacent to Bldg. 5, Bldg. 3 and former Fountain Circle South of Bldg. 5: Remove and re-install 9 areas of walkway, as indicated by field markings, estimated at 1212 sq. ft.
12. Omitted

**Unit Prices:**

Definition: Unit price is stated on the Bid Form as a price per unit of measurement for materials and/or services added to or deducted from the Contract Sum by appropriate Change Order, if quantities of Work required by the Contract Documents need increased or decreased based on unforeseen circumstances or field conditions. Unit prices include all necessary material, plus all associated costs (delivery, installation, insurance, overhead and profit, etc)

**Schedule of Unit Prices**

Item 1 - ADDITIONAL SIDEWALK REPLACEMENT: Unit Price is based on flat concrete surfaces, including removal of existing concrete, preparation of sub base and base materials, placing concrete, and landscape restoration after repair. Unit Price shall be on a square foot basis. 12.

Item 2- ADDITIONAL SIDEWALK JOINT REPAIRS: Unit Price is based on saw cutting the existing concrete slabs at eight (8") inches either side of a deteriorated concrete joint, removing



State of West Virginia  
General Services Division

West Virginia State Capitol  
Campus Concrete Repair  
Project GSD116457

the deteriorated area, replacing the concrete and cleanup after the repair. Unit Price shall be on a lineal foot basis.

~~Item 3 - ADDITIONAL CONCRETE CURB REPLACEMENT: Unit Price is based on saw cutting the existing concrete curb, removing the deteriorated area, replacing the concrete curb and cleanup after the repair. Unit Price shall be on a lineal foot basis.~~

Item 4 – ADDITIONAL ADA TRANSITION INSTALLATION: Unit Price is based on complete preparation of an area and the installation of an ADA compliant transition on either a straight sidewalk or sidewalk corner.

**Contract Period:**

The Contract shall be substantially completed within **Sixty (60)** calendar days from the issuance of the written Notice to Proceed. In accordance with the West Virginia State Code 5A-3-4(8), vendor agrees that liquidated damages shall be imposed at the rate of \$250.00 per day for failure to complete the project within the contract period. This clause shall in no way be considered exclusive and shall not limit the State or Agency's right to pursue any other additional remedy to which the State or Agency may have legal cause for action including further damages against the vendor.

**Reference Requirement:**

The qualified Contractor shall have at least three years experience performing such work on projects of a similar size and type. Bidders shall supply at least three references indicating their capabilities to perform such work. References shall include the name, location, ownership and use of the building in addition to the name, address and telephone number of a contact person with the building's owner familiar with the previous work.

**Payment:**

The Contractor shall submit two copies (one original and one copy) of invoice at conclusion of project on AIA forms G702 and G703. Invoices shall be signed in blue ink. Deliver invoices to:

General Services Division  
Attn: Business Manager  
1900 Kanawha Blvd. East  
Building 1, Room MB-60  
Charleston, West Virginia 25305

**General Conditions:**

1. The relationship of the Contractor to the Owner shall be that of an independent contractor and no principal-agent relationship or employer-employee relationship is contemplated or created by the parties to this Contract. The Contractor as an independent contractor is solely

State of West Virginia  
General Services Division

West Virginia State Capitol  
Campus Concrete Repair  
Project GSD116457

liable for the acts and omissions of its employees and agents. The Contractor shall be responsible for selecting, supervising and compensating any and all individuals employed pursuant to the terms of this contract. Neither the Contractor nor any employees or subcontractors of the Contractor shall be deemed to be employees of the State for any purposes whatsoever. The wages and salaries, taxes, withholding payments, penalties, fees, fringe benefits, professional liability insurance premiums, contributions to insurance and pension or other deferred obligations and licensing fees, etc., and the filing of all necessary documents, forms and returns pertinent to all of the foregoing are the Contractor's responsibility. The Contractor shall hold harmless the State, and shall provide the State and Agency with a defense against any and all claims including but not limited to the foregoing payments, withholdings, contributions, taxes, social security taxes, and employer income tax returns. The Contractor shall not assign, convey, transfer, sub-contract, or delegate any of its responsibilities and obligations under this contract to any person, corporation, partnership association or entity without expressed written consent of the agency.

2. Indemnification: The Contractor agrees to indemnify, defend, and hold harmless the State and the Owner, their officers, and employees from and against (1) any claims or losses for services rendered by any subcontractor, person or firm performing or supplying services, materials, or supplies in connection with the performance of the Contract; (2) Any claims or losses resulting to any person or entity injured or damaged by the Contractor, its officers, employees, or subcontractors by the publication, translation, reproduction, delivery, performance, use, or deposition of any data used under the Contract in a manner not authorized by the Contract, or by Federal or State statutes or regulations; (3) Any failure of the Contractor, its officers, employees or sub-contractors to observe State and Federal laws, including but not limited to labor and wage laws.

3. This Contract shall be governed by the laws of the State of West Virginia. The Contractor further agrees to comply with the Civil Rights Act of 1964 and all other applicable Federal, State, and local Government regulations.

4. The Contractor shall procure all necessary permits and licenses to comply with all applicable laws, Federal, State, or municipal, along with all regulations, and ordinances of any regulating body.

5. The Contractor shall pay any applicable sales, use, or personal property taxes, arising out of this Contract and the transactions contemplated thereby. Any other taxes levied upon this Contract, the transaction, or the equipment, or services delivered pursuant hereto shall be borne by the Contractor. It is clearly understood that the State of West Virginia is exempt from any taxes regarding performance of the scope of work of this Contract.

6. Contractor shall be responsible for parts and materials as follows:

- A. The Contractor shall supply all tools, tool accessories, personal safety equipment, and supplies necessary to execute the responsibilities of this Contract.
- B. Contractor shall furnish a warranty of twelve (12) months for labor and materials.

State of West Virginia  
General Services Division

West Virginia State Capitol  
Campus Concrete Repair  
Project GSD116457

**Bonds and Insurance:**

Refer to Purchasing Division's 'Request for Quotation' for requirements on bonding; insurance; wage rates; "Foreign made aluminum, glass and steel in Public Works Projects", and other project requirements.

**Submittals:**

All submittals for this project shall be reviewed and approved by the Owner's Project Manager assigned to review this project.

**Project Closeout:**

1. Final cleanup shall be completed prior to final acceptance.
2. If specified elsewhere, submit records of quality assurance testing.
3. Submit "Affidavit of Payment of Debts and Claims."

**Final Inspection:**

The Final Inspection will be conducted by the Owner's Project Manager.

Work found to be in accordance with the Contract Documents will be accepted as complete for final acceptance. Unacceptable work, or work not in accordance with the Contract Documents shall be removed, replaced, changed or cleaned as required to meet requirements of Contract Documents prior to final acceptance. Final Acceptance does not waive or release Contractor to conform to the Contract Documents.

The date of Substantial Completion shall be determined by the Project Manager conducting the final inspection based on all work being complete for final acceptance or substantially complete to permit beneficial use by the Owner. Final payment shall not be made until all work is finally accepted.

**Limits of Work**

Work areas will be limited to those spaces required for access to the sidewalks and delivery of materials to the work area. Coordinate deliveries to work area. A single access route will be provided for concrete deliveries. Note that contractor shall be responsible of damage to existing drives, walks and landscaping along the delivery routes. Repair all damage prior to completion.

Coordinate with Owner for temporary (overnight) storage space for equipment and tools.

Provide yellow marking tape, fencing, barriers and other applicable traffic control devices to direct traffic around sidewalks under repair and other construction areas. Provide detour routes

State of West Virginia  
General Services Division

West Virginia State Capitol  
Campus Concrete Repair  
Project GSD116457

when applicable. Separate the construction traffic from pedestrian and vehicular traffic on the site.

The buildings and office spaces shall remain in use during this contract. Contractor shall work with the Building Managers and Protective Services to coordinate the temporary access to work areas, the movement of materials and otherwise provide for the Contractor needs during construction. Contractor shall minimize disruption to Capitol work areas.

### **Use of Facilities**

Contractor shall be permitted reasonable use of building utilities including power and water as required for conducting the work. Coordinate the location of service connections or use of receptacles with the Building Manager to avoid overloading existing circuits.

### **Contractor Schedule:**

Provide overall project schedule within seventy-two hours of Notice to Proceed.

Proposed construction schedule shall indicate when sidewalks will be replaced and the length of time required to complete that section. Coordinate schedule with Owner.

### **Waste Removal**

Contractor to make arrangements for the collection and disposal of Contractor's waste and construction related debris. Debris shall be removed on a daily basis.

### **Contractor Visitor Badges**

The Capitol Complex is a semi-secure facility. Contractor shall provide a list of all personnel working on this project within the Complex. This list shall include a copy of a valid driver's license or other legal identification and include date of birth and social security number. All proposed workers may be subjected to a criminal history / driver's license background check prior to being permitted to work in state buildings. Workers shall carry valid Contractor Photo ID Badges to be worn when working in the building. Under no circumstances shall a worker be assigned to this project without the validation first being submitted to the General Services Division and approval given.

### **Work Restrictions:**

Work shall be generally performed on the campus during normal business working hours of 7:00 am to 5:00 pm, Monday through Friday, except state recognized holidays.

This is a non-smoking campus: Smoking is not permitted within the buildings or near entrances, operable windows or outdoor air intakes. The sidewalk areas are necessary to the functioning of Capitol Campus. Expect traffic during work periods. Traffic through the doors cannot be blocked for extended or unscheduled periods of time. Secure work area when unattended or

State of West Virginia  
General Services Division

West Virginia State Capitol  
Campus Concrete Repair  
Project GSD116457

after hours.

### **Parking**

No parking is available on the site. The Contractor is responsible for providing all off-site parking required for the project. Provisions will be made for locating refuse dumpsters if required by the project.

**Use of sidewalk areas for parking is strictly prohibited.** With prior approval, contractor's vehicles may be brought on-site for loading & unloading or to provide equipment necessary for conducting the work. Vehicles not necessary for conduct of work shall be removed from site within one-half hour.

### **Codes:**

All work is to be performed in compliance with applicable Federal and State codes including but not limited to the International Building Code, International Mechanical Code, Life Safety Code, ACI, NEC, OSHA, UL, ANSI, ASME and related standards. Sidewalks shall also meet applicable ADA (Americans with Disabilities Act) requirements.

### **Safety:**

Perform all work in compliance with applicable safety regulations. Work shall be subject to verification and inspection by GSD Safety representatives. Such verification shall not relieve the Contractor from meeting all applicable safety regulations and inspection by other agencies. Notify Owner if suspected hazardous materials are encountered.

### **Hot Work Permit:**

Contractor shall obtain Owner's permission prior to performing any work that requires an open flame, creates sparks, use's equipment that creates combustible temperatures, or performs any work that could result in a fire hazard. Owner will review work area and issue a 'Hot Work Permit' prior to Contractor commencing work. Note that the Contractor must take proper precautions and may be required to provide a Fire Watch as a condition of the permit.

### **Workmanship:**

Contractor shall complete all work in a neat and workmanlike manner. All work shall be done using new materials in a manner that meets commercial quality standards. Work shall be neat, true, plumb and square, as applicable. Contractor shall verify all dimensions.

### **Warranty:**

In addition to individual material warranties, Contractor shall warranty all work for a period of one year from the date of final completion.

State of West Virginia  
General Services Division

West Virginia State Capitol  
Campus Concrete Repair  
Project GSD116457

**Award Criteria:**

The State will award this Contract to the contractor meeting the mandatory requirements with the lowest overall project bid. The lowest overall bid will be based on the 'Total Contract Bid' as submitted on the attached Bid Form.

---

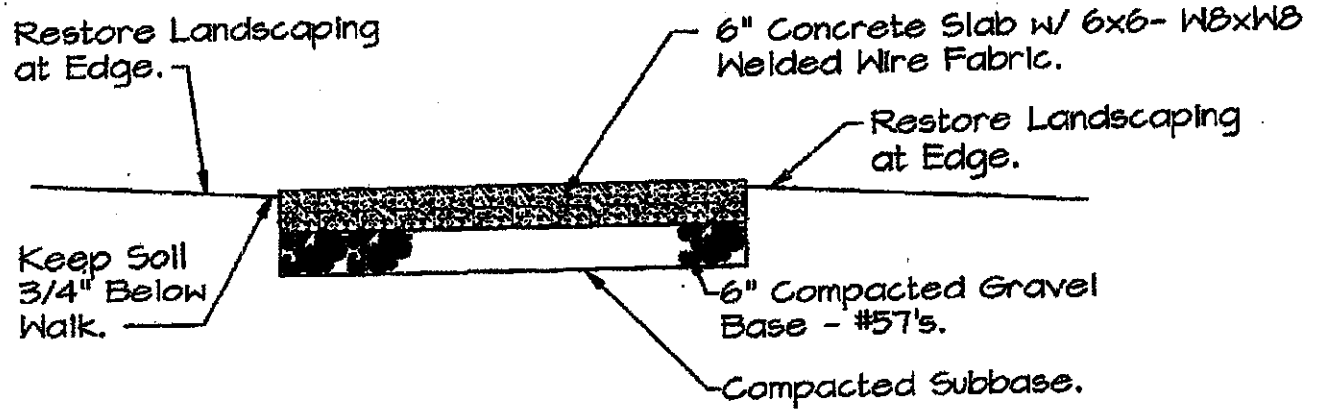

SIDEWALK SECTION

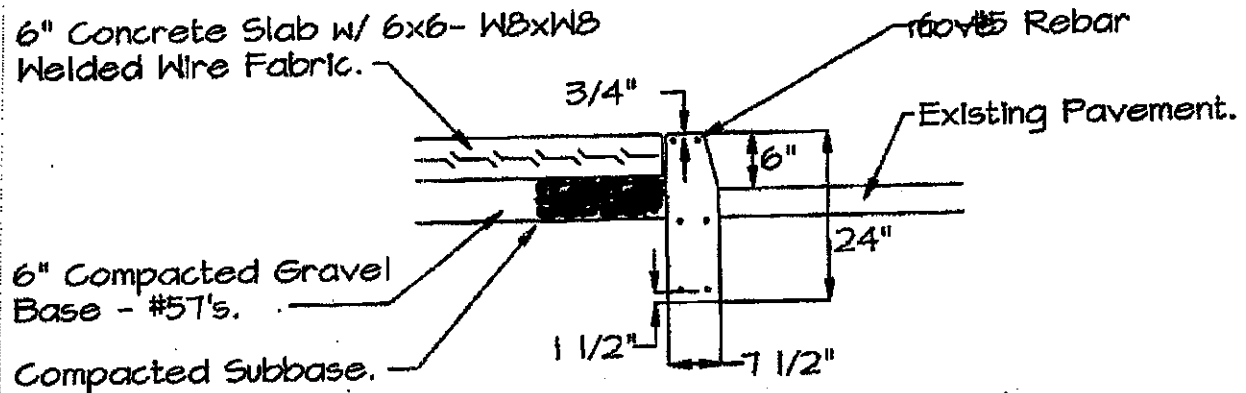

CURB AT SIDEWALK

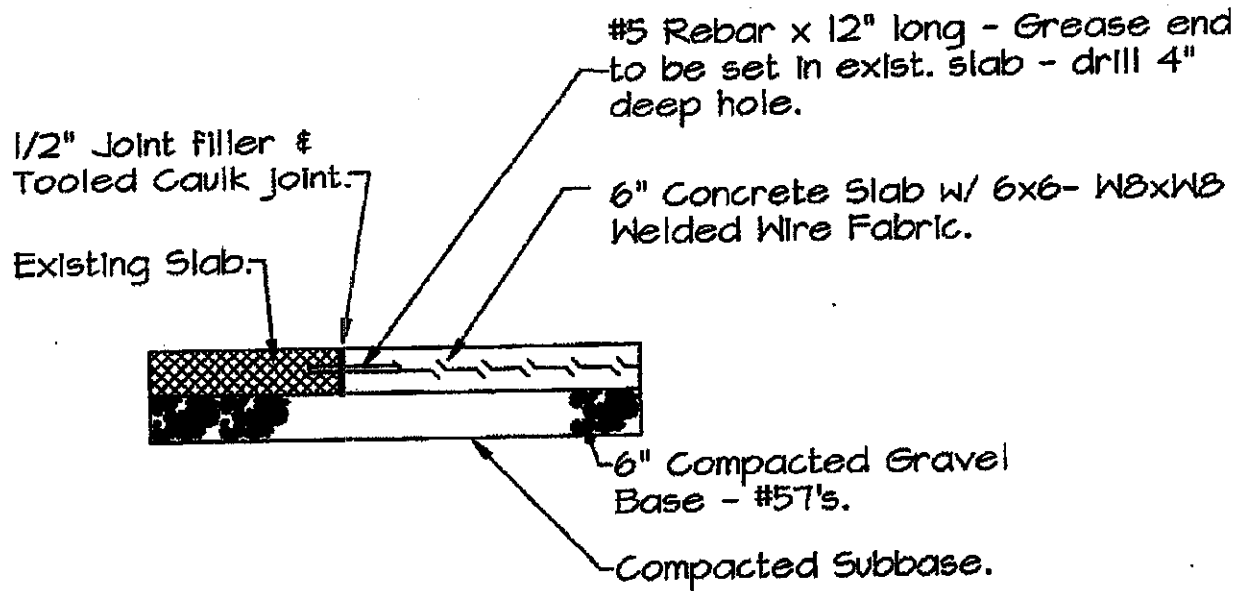

EXPANSION JOINT DETAIL



SECTION 03300 - CAST-IN-PLACE CONCRETE

PART 1 - GENERAL

1.1 SUMMARY

- A. This Section specifies cast-in place concrete, including formwork, reinforcement, concrete materials, mixture design, placement procedures, and finishes.

1.2 SUBMITTALS

- A. Product Data: For each type of product indicated.
- B. Design Mixtures: For each concrete mixture.
- C. Shop Drawings: For steel reinforcement and formwork. Material certificates. Provide Sketch showing control / expansion joint patterns at each segment over five feet in with.

1.3 QUALITY ASSURANCE

- A. Manufacturer Qualifications: A firm experienced in manufacturing ready-mixed concrete products and that complies with ASTM C 94/C 94M requirements for production facilities and equipment.
  - 1. Manufacturer certified according to NRMCA's "Certification of Ready Mixed Concrete Production Facilities."
- B. ACI Publications: Comply with the following unless modified by requirements in the Contract Documents:
  - 1. ACI 301, "Specification for Structural Concrete," Sections 1 through 5.
  - 2. ACI 117, "Specifications for Tolerances for Concrete Construction and Materials."

PART 2 - PRODUCTS

2.1 FORM-FACING MATERIALS

- A. Smooth-Formed Finished Concrete: Form-facing panels that will provide continuous, true, and smooth concrete surfaces. Furnish in largest practicable sizes to minimize number of joints.

2.2 STEEL REINFORCEMENT

- A. Reinforcing Bars: ASTM A 615/A 615M, Grade 60, deformed.

- B. Plain-Steel Welded Wire Reinforcement: ASTM A 185, plain, fabricated from as-drawn steel wire into flat sheets.
- C. Bar Supports: Bolsters, chairs, spacers, and other devices for spacing, supporting, and fastening reinforcing bars and welded wire reinforcement in place. Manufacture bar supports from steel wire, plastic, or precast concrete according to CRSI's "Manual of Standard Practice."

## 2.3 CONCRETE MATERIALS

- A. Cementitious Material: Portland Cement: ASTM C 150, Type I
- B. Normal-Weight Aggregates: ASTM C 33, graded, 3/4-inch nominal maximum coarse-aggregate size.
  - 1. Fine Aggregate: Free of materials with deleterious reactivity to alkali in cement.
- C. Water: ASTM C 94/C 94M and potable.
- D. Air-Entraining Admixture: ASTM C 260.
- E. Chemical Admixtures: Provide admixtures certified by manufacturer to be compatible with other admixtures and that will not contribute water-soluble chloride ions exceeding those permitted in hardened concrete. Do not use calcium chloride or admixtures containing calcium chloride.
  - 1. Water-Reducing Admixture: ASTM C 494/C 494M, Type A.
  - 2. Retarding Admixture: ASTM C 494/C 494M, Type B.

## 2.4 CURING MATERIALS

- A. Evaporation Retarder: Waterborne, monomolecular film forming, manufactured for application to fresh concrete.
- B. Absorptive Cover: AASHTO M 182, Class 2, burlap cloth made from jute or kenaf, weighing approximately 9 oz./sq. yd. when dry.
- C. Moisture-Retaining Cover: ASTM C 171, polyethylene film or white burlap-polyethylene sheet.
- D. Water: Potable.

## 2.5 RELATED MATERIALS

- A. Expansion- and Isolation-Joint-Filler Strips: [ASTM D 1751, asphalt-saturated cellulosic fiber.

## 2.6 CONCRETE MIXTURES

- A. Prepare design mixtures for each type and strength of concrete, proportioned on the basis of laboratory trial mixture or field test data, or both, according to ACI 301.
- B. Cementitious Materials: Use fly ash, pozzolan, and silica fume as needed to reduce the total amount of portland cement, which would otherwise be used, by not less than 40 percent.
- C. Proportion normal-weight concrete mixture as follows:
  - 1. Minimum Compressive Strength: 4000 psi at 28 days.
  - 2. Maximum Water-Cementitious Materials Ratio: 0.45.
  - 3. Slump Limit: 3 inch, plus or minus 1 inch.
  - 4. Air Content: 7 percent, plus or minus 1.5 percent at point of delivery for 3/4-inch nominal maximum aggregate size.

## 2.7 FABRICATING REINFORCEMENT

- A. Fabricate steel reinforcement according to CRSI's "Manual of Standard Practice."

## 2.8 CONCRETE MIXING

- A. Ready-Mixed Concrete: Measure, batch, mix, and deliver concrete according to ASTM C 94/C 94M, and furnish batch ticket information.
  - 1. When air temperature is between 85 and 90 deg F reduce mixing and delivery time from 1-1/2 hours to 75 minutes; when air temperature is above 90 deg F reduce mixing and delivery time to 60 minutes.

## PART 3 - EXECUTION

### 3.1 FORMWORK

- A. Design, erect, shore, brace, and maintain formwork according to ACI 301 to support vertical, lateral, static, and dynamic loads, and construction loads that might be applied, until structure can support such loads.
- B. Construct formwork so concrete members and structures are of size, shape, alignment, elevation, and position indicated, within tolerance limits of ACI 117.
- C. Chamfer exterior corners and edges of permanently exposed concrete.

### 3.2 STEEL REINFORCEMENT

- A. General: Comply with CRSI's "Manual of Standard Practice" for placing reinforcement.

### 3.3 JOINTS

- A. General: Construct joints true to line with faces perpendicular to surface plane of concrete.
- B. Construction Joints: Install so strength and appearance of concrete are not impaired, at locations indicated or as approved by Architect.
- C. Contraction Joints in Slabs-on-Grade: Form weakened-plane contraction joints, sectioning concrete into areas as indicated. Construct contraction joints for a depth equal to at least one-fourth of concrete thickness as follows:
  - 1. Grooved Joints: Form contraction joints after initial floating by grooving and finishing each edge of joint to a radius of 1/8 inch. Repeat grooving of contraction joints after applying surface finishes. Eliminate groover tool marks on concrete surfaces.
  - 2. Sawed Joints (where approved): Form contraction joints with power saws equipped with shatterproof abrasive or diamond-rimmed blades. Cut 1/8-inch wide joints into concrete when cutting action will not tear, abrade, or otherwise damage surface and before concrete develops random contraction cracks.
- D. Isolation Joints in Slabs-on-Grade: After removing formwork, install joint-filler strips at slab junctions with vertical surfaces, such as column pedestals, foundation walls, grade beams, and other locations, as indicated.

### 3.4 CONCRETE PLACEMENT

- A. Before placing concrete, verify that installation of formwork, reinforcement, and embedded items is complete and that required inspections have been performed.
- B. Deposit concrete continuously in one layer or in horizontal layers of such thickness that no new concrete will be placed on concrete that has hardened enough to cause seams or planes of weakness. If a section cannot be placed continuously, provide construction joints as indicated. Deposit concrete to avoid segregation.
  - 1. Consolidate placed concrete with mechanical vibrating equipment according to ACI 301.
- C. Cold-Weather Placement: Comply with ACI 306.1.
- D. Hot-Weather Placement: Comply with ACI 301.

### 3.5 FINISHING FORMED SURFACES

- A. Rubbed Finish: Apply the following to smooth-formed finished as-cast concrete where indicated:
  - 1. Smooth-Rubbed Finish: Wet concrete surfaces and apply grout of a consistency of thick paint to coat surfaces and fill small holes. Mix one part portland cement to one and one-half parts fine sand with a 1:1 mixture of bonding admixture and water. Add white portland cement in amounts determined by trial patches so color of dry grout will match

adjacent surfaces. Scrub grout into voids and remove excess grout. When grout whitens, rub surface with clean burlap and keep surface damp by fog spray for at least 36 hours.

- B. Related Unformed Surfaces: At tops of walls, horizontal offsets, and similar unformed surfaces adjacent to formed surfaces, strike off smooth and finish with a texture matching adjacent formed surfaces. Continue final surface treatment of formed surfaces uniformly across adjacent unformed surfaces, unless otherwise indicated.

### 3.6 FINISHING SIDEWALKS AND SLABS

- A. General: Comply with ACI 302.1R recommendations for screeding, restraightening, and finishing operations for concrete surfaces. Do not wet concrete surfaces.
- B. Trowel Finish: After applying float finish, apply first troweling and consolidate concrete by hand or power-driven trowel. Continue troweling passes and restraighten until surface is free of trowel marks and uniform in texture and appearance. Grind smooth any surface defects that would telegraph through applied coatings or floor coverings.
  - 1. Apply a trowel finish to surfaces.
  - 2. Finish and measure surface so gap at any point between concrete surface and an unlevelled, freestanding, 10-foot-long straightedge resting on 2 high spots and placed anywhere on the surface does not exceed 3/16 inch .
- C. Trowel and Fine-Broom Finish: Apply a first trowel finish to sidewalk surfaces. While concrete is still plastic, slightly scarify surface with a fine broom. Comply with flatness and levelness tolerances for trowel finished floor surfaces.

### 3.7 CONCRETE PROTECTING AND CURING

- A. General: Protect freshly placed concrete from premature drying and excessive cold or hot temperatures. Comply with ACI 306.1 for cold-weather protection and ACI 301 for hot-weather protection during curing.
- B. Evaporation Retarder: Apply evaporation retarder to unformed concrete surfaces if hot, dry, or windy conditions cause moisture loss approaching 0.2 lb/sq. ft. x h before and during finishing operations. Apply according to manufacturer's written instructions after placing, screeding, and bull floating or darbying concrete, but before float finishing. Evaporation retarder shall not be the sole means of curing.
- C. Cure concrete according to ACI 308.1, by Moisture-Retaining-Cover Curing: Cover concrete surfaces with moisture-retaining cover for curing concrete, placed in widest practicable width, with sides and ends lapped at least 12 inches, and sealed by waterproof tape or adhesive. Cure for not less than seven days. Immediately repair any holes or tears during curing period using cover material and waterproof tape.

3.8 CONCRETE SURFACE REPAIRS

- A. Defective Concrete: Remove and replace concrete defective concrete.

3.9 FIELD QUALITY CONTROL

- 1. Testing and Inspecting: If required, Owner will engage a qualified independent testing and inspecting agency to perform field tests and inspections and prepare test reports.

END OF SECTION 03300

**PART 1 - EARTH WORK SPECIFICATIONS****1.1 SUMMARY****A. This Section includes the following:**

1. Preparing sub-grades for slabs-on-grades, walks
2. Drainage course for slabs-on-grade.
3. Sub-base course for concrete walks.

**1.2 DEFINITIONS**

- A. **Initial Backfill:** Backfill placed beside and over pipe in a trench, including haunches to support sides of pipe.
- B. **Final Backfill:** Backfill placed over initial backfill to fill a trench.
- C. **Base Course:** Course placed between the sub-base course and hot-mix asphalt paving.
- D. **Bedding Course:** Course placed over the excavated sub-grade in a trench before laying pipe.
- E. **Borrow Soil:** Satisfactory soil imported from off-site for use as fill or backfill.
- F. **Drainage Course:** Course supporting the slab-on-grade that also minimizes upward capillary flow of pore water.
- G. **Excavation:** Removal of material encountered above sub-grade elevations and to lines and dimensions indicated.
  1. **Unauthorized Excavation:** Excavation below sub-grade elevations or beyond indicated lines and dimensions without direction by General Services Division Engineering Manager or his designee. Unauthorized excavation, as well as remedial work directed by, shall be without additional compensation.
- H. **Fill:** Soil materials used to raise existing grades.
- I. **Sub-base Course:** Course placed between the sub-grade and base course for hot-mix asphalt pavement, or course placed between the sub-grade and a cement concrete pavement or a cement concrete or hot-mix asphalt walk.
- J. **Sub-grade:** Surface or elevation remaining after completing excavation, or top surface of a fill or backfill immediately below sub-base, drainage fill, or topsoil materials.

## PART 2 - PRODUCTS

### 2.1 SOIL MATERIALS – TO BE PERFORMED BY CONTRACTOR EXCEPT C, C1.

- A. General: Provide borrow soil materials when sufficient satisfactory soil materials are not available from excavations.
- B. Satisfactory Soils: ASTM D 2487 Soil Classification Groups GW, GP, GM, SW, SP, and SM or a combination of these groups; free of rock or gravel larger than 3 inches in any dimension, debris, waste, frozen materials, vegetation, and other deleterious matter.
- C. Unsatisfactory Soils: Soil Classification Groups GC, SC, CL, ML, OL, CH, MH, OH, and PT according to ASTM D 2487 A-2-6, A-2-7, A-4, A-5, A-6, and A-7 according to AASHTO M 145, or a combination of these groups.
  - 1. Unsatisfactory soils also include satisfactory soils not maintained within 2 percent of optimum moisture content at time of compaction.
- D. Crushed stone, and natural or crushed sand; ASTM D 2940; with at least 90 percent passing a 1-1/2-inch sieve and not more than 12 percent passing a No. 200 sieve.
- E. Base Course: Naturally or artificially graded mixture of natural or crushed gravel, crushed stone, and natural or crushed sand; ASTM D 2940; with at least 95 percent passing a 1-1/2-inch sieve and not more than 8 percent passing a No. 200 sieve.
- F. Engineered Fill: Naturally or artificially graded mixture of natural or crushed gravel, crushed stone, and natural or crushed sand; ASTM D 2940; with at least 90 percent passing a 1-1/2-inch sieve and not more than 12 percent passing a No. 200 sieve.
- G. Bedding Course: Naturally or artificially graded mixture of natural or crushed gravel, crushed stone, and natural or crushed sand; ASTM D 2940; except with 100 percent passing a 1-inch sieve and not more than 8 percent passing a No. 200 sieve.
- H. Drainage Course: Narrowly graded mixture of crushed stone, or crushed or uncrushed gravel; ASTM D 448; coarse-aggregate grading Size 57; with 100 percent passing a 1-1/2-inch sieve and 0 to 5 percent passing a No. 8 sieve.

## PART 3 - EXECUTION

### 3.1 PREPARATION – TO BE PERFORMED BY CONTRACTOR

- A. Protect structures, utilities, sidewalks, pavements, and other facilities from damage caused by settlement, lateral movement, undermining, washout, and other hazards created by earthwork operations.



- B. Preparation of sub-grade for earthwork operations including removal of vegetation, topsoil, debris, obstructions, and deleterious materials from ground surface is specified in Division 2 Section "Site Clearing."
- C. Protect and maintain erosion and sedimentation controls, which are specified in Division 2 Section "Site Clearing," during earthwork operations.

### 3.2 EXCAVATION – TO BE PERFORMED BY CONTRACTOR

- A. **Unclassified Excavation:** Excavate to sub-grade elevations regardless of the character of surface and subsurface conditions encountered. Unclassified excavated materials may include rock, soil materials, and obstructions. No changes in the Contract Sum or the Contract Time will be authorized for rock excavation or removal of obstructions.
  - 1. If excavated materials intended for fill and backfill include unsatisfactory soil materials and rock, replace with satisfactory soil materials.

### 3.3 EXCAVATION FOR WALKS AND PAVEMENTS – TO BE PERFORMED BY CONTRACTOR

- A. Excavate surfaces under walks and pavements to indicated lines, cross sections, elevations, and sub-grades.

### 3.4 UNAUTHORIZED EXCAVATION

- A. Fill unauthorized excavation under foundations or wall footings by extending bottom elevation of concrete foundation or footing to excavation bottom, without altering top elevation. Lean concrete fill, with 28-day compressive strength of 2500 psi, may be used when approved by Architect.
  - 1. Fill unauthorized excavations under other construction or utility pipe as directed by General Services Division Engineering Manager or his designee.

### 3.5 COMPACTION OF SOIL BACKFILLS AND FILLS – TO BE PERFORMED BY CONTRACTOR

- A. Place backfill and fill soil materials in layers not more than 8 inches in loose depth for material compacted by heavy compaction equipment, and not more than 4 inches in loose depth for material compacted by hand-operated tampers.
- B. Place backfill and fill soil materials evenly on all sides of structures to required elevations, and uniformly along the full length of each structure.

C. Compact soil materials to not less than the following percentages of maximum dry unit weight according to ASTM D 698.

1. Under structures, building slabs, steps, and pavements, scarify and recompact top 12 inches of existing sub-grade and each layer of backfill or fill soil material at 95 percent.

### 3.6 SUBBASE AND BASE COURSES – TO BE PERFORMED BY CONTRACTOR

A. Place sub-base course on sub-grades free of mud, frost, snow, or ice.

B. On prepared sub-grade, place sub-base course under pavements and walks as follows:

1. Shape sub-base course to required crown elevations and cross-slope grades.
2. Compact sub-base course at optimum moisture content to required grades, lines, cross sections, and thickness to not less than 95 percent of maximum dry unit weight according to ASTM D 698

### 3.7 DRAINAGE COURSE – TO BE PERFORMED BY CONTRACTOR

A. Place drainage course on sub-grades free of mud, frost, snow, or ice.

B. On prepared sub-grade, place and compact drainage course under cast-in-place concrete slabs-on-grade as follows:

1. Place drainage course that exceeds 6 inches in compacted thickness in layers of equal thickness, with no compacted layer more than 6 inches thick or less than 6 inches thick.
2. Compact each layer of drainage course to required cross sections and thicknesses to not less than 95 percent of maximum dry unit weight according to ASTM D 698.

### 3.8 PROTECTION – TO BE PERFORMED BY CONTRACTOR

A. Protecting Graded Areas: Protect newly graded areas from traffic, freezing, and erosion. Keep free of trash and debris.

B. Repair and establish grades to specific tolerances where completed or partially completed surfaces become eroded, rutted, settled, or where they lose compaction due to subsequent construction operations or weather conditions.

C. Where settling occurs before Project correction period elapses, remove finished surfacing, backfill with additional soil material, compact, and reconstruct surfacing.

1. Restore appearance, quality, and condition of finished surfacing to match adjacent work, and eliminate evidence of restoration to greatest extent possible.





State of West Virginia  
DRUG FREE WORKPLACE CONFORMANCE AFFIDAVIT  
West Virginia Code §21-1D-5

STATE OF West Virginia

COUNTY OF Fayette, TO-WIT:

I, Robert D. Hill, after being first duly sworn, depose and state as follows:

- 1. I am an employee of Danhill Construction Company; and,  
(Company Name)
- 2. I do hereby attest that Danhill Construction Company  
(Company Name)

maintains a valid written drug free workplace policy and that such policy is in compliance with **West Virginia Code §21-1D-5**.

The above statements are sworn to under the penalty of perjury.

Danhill Construction Company  
(Company Name)

By: Robert D. Hill

Title: President

Date: 6/30/2011

Taken, subscribed and sworn to before me this 30 day of June 2011.

By Commission expires 3/28/2015

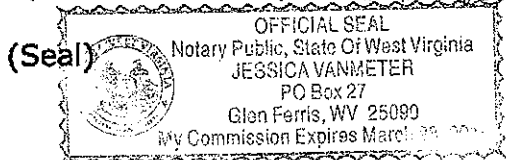

Jessica VanMeter  
(Notary Public)

**THIS AFFIDAVIT MUST BE SUBMITTED WITH THE BID IN ORDER TO COMPLY WITH WV CODE PROVISIONS. FAILURE TO INCLUDE THE AFFIDAVIT WITH THE BID SHALL RESULT IN DISQUALIFICATION OF THE BID.**

State of West Virginia  
Department of Administration

General Services Division  
GSD116457 Campus Concrete Repairs

**REQUEST FOR QUOTATIONS #GSD116457**

**Capitol Campus  
Concrete Repairs**

**BID FORM**

Bidder's Company Name: Danhill Construction Company

Bidder's Address: P.O. Box 685  
Barley Bridge, W.V. 25085

Remittance Address: \_\_\_\_\_  
(if different)

Phone Number: 304-632-1600

Fax Number: 304-632-1501

Email Address: rdanhill@hotmail.com

WV Contractor's License Number: WV001196

We, the undersigned, having examined the site and being familiar with the local conditions affecting the cost of the work and also being familiar with the general conditions to bidders, drawings, and specifications, hereby propose to furnish all materials, equipment, and labor to complete all work in a workmanlike manner, as described in the Bidding Documents.

**TOTAL CONTRACT BID**

Two Hundred And Fifty-Eight Thousand Nine Hundred  
(\$ 258,900.00 ) Dollar S  
(Total to be written in words and numbers.)

State of West Virginia  
Department of Administration

General Services Division  
GSD116457 Campus Concrete Repairs

**Unit Pricing:**

For the purposes of processing any change orders to this contract at a later date, please provide the following Unit Prices:

Item 1 - ADDITIONAL SIDEWALK REPLACEMENT: Unit Price is based on flat concrete surfaces, including removal of existing concrete, preparation of sub base and base materials, placing concrete, and landscape restoration after repair. Unit Price shall be on a square foot basis.

Cost per Square Foot: \$ 15.00

Item 2- ADDITIONAL SIDEWALK JOINT REPAIRS: Unit Price is based on saw cutting the existing concrete slabs at eight (8") inches either side of a deteriorated concrete joint, removing the deteriorated area, replacing the concrete and cleanup after the repair. Unit Price shall be on a lineal foot basis.

Cost per Lineal Foot: \$ 200.00

Item 3 - ADDITIONAL CONCRETE CURB REPLACEMENT: Unit Price is based on saw cutting the existing concrete curb, removing the deteriorated area, replacing the concrete curb and cleanup after the repair. Unit Price shall be on a lineal foot basis.

Cost per Lineal Foot: \$ 375.00

Item 4 – ADDITIONAL ADA TRANSITION INSTALLATION: Unit Price is based on complete preparation of an area and the installation of an ADA compliant transition on either a straight sidewalk or sidewalk corner.

Cost Each: <sup>RPT</sup> \$ 2,400.00

It is expressly understood that the Unit Prices are for the purposes of change orders only, and that their value does not need to correlate to, nor will it be factored into, calculation or evaluation of the Total Contract Bid.

State of West Virginia  
Department of Administration

General Services Division  
GSD116457 Campus Concrete Repairs

References

Reference Name: Mike Mace  
Position: Project Manager  
Address: PO Box 59701, Charleston, WV 25356-9701  
Telephone Number: 304-746-5282  
Project Name: Huntington PD Sidewalk Replacement  
Project Description: Sidewalk Replacement

Reference Name: Mike Mace  
Position: Project Manager  
Address: PO Box 59701, Charleston, WV 25350-9701  
Telephone Number: 304-746-5282  
Project Name: Charleston PD Delivery Unit Renovations  
Project Description: Full remodel w/ new concrete dock + floors

Reference Name: Susan O'Connell  
Position: Project Manager  
Address: Bldg 5, Room 906, 1900 Kanawha Blvd. E. Charleston, WV 25305-0132  
Telephone Number: 304-558-0428  
Project Name: Tri. River Transit Authority Bus Garage + office Building  
Project Description: New construction w/ concrete slabs + sidewalks.

RFQ No. GSD116457

STATE OF WEST VIRGINIA  
Purchasing Division

**PURCHASING AFFIDAVIT**

**West Virginia Code §5A-3-10a states:** No contract or renewal of any contract may be awarded by the state or any of its political subdivisions to any vendor or prospective vendor when the vendor or prospective vendor or a related party to the vendor or prospective vendor is a debtor and the debt owed is an amount greater than one thousand dollars in the aggregate.

**DEFINITIONS:**

"Debt" means any assessment, premium, penalty, fine, tax or other amount of money owed to the state or any of its political subdivisions because of a judgment, fine, permit violation, license assessment, defaulted workers' compensation premium, penalty or other assessment presently delinquent or due and required to be paid to the state or any of its political subdivisions, including any interest or additional penalties accrued thereon.

"Debtor" means any individual, corporation, partnership, association, limited liability company or any other form or business association owing a debt to the state or any of its political subdivisions. "Political subdivision" means any county commission; municipality; county board of education; any instrumentality established by a county or municipality; any separate corporation or instrumentality established by one or more counties or municipalities, as permitted by law; or any public body charged by law with the performance of a government function or whose jurisdiction is coextensive with one or more counties or municipalities. "Related party" means a party, whether an individual, corporation, partnership, association, limited liability company or any other form or business association or other entity whatsoever, related to any vendor by blood, marriage, ownership or contract through which the party has a relationship of ownership or other interest with the vendor so that the party will actually or by effect receive or control a portion of the benefit, profit or other consideration from performance of a vendor contract with the party receiving an amount that meets or exceed five percent of the total contract amount.

**EXCEPTION:** The prohibition of this section does not apply where a vendor has contested any tax administered pursuant to chapter eleven of this code, workers' compensation premium, permit fee or environmental fee or assessment and the matter has not become final or where the vendor has entered into a payment plan or agreement and the vendor is not in default of any of the provisions of such plan or agreement.

Under penalty of law for false swearing (*West Virginia Code §61-5-3*), it is hereby certified that the vendor affirms and acknowledges the information in this affidavit and is in compliance with the requirements as stated.

**WITNESS THE FOLLOWING SIGNATURE**

Vendor's Name: Danhill Construction Company

Authorized Signature: Robert D. Hill Date: 6/20/2011

State of West Virginia

County of Fayette, to-wit:

Taken, subscribed, and sworn to before me this 30 day of June, 2011.

My Commission expires March 23, 2015.

**AFFIX SEAL HERE**

**NOTARY PUBLIC**

Jessica VanMeter

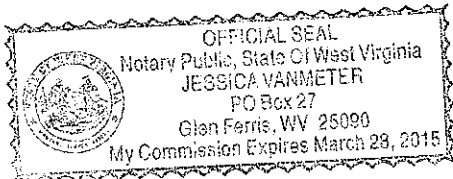





State of West Virginia  
 Department of Administration  
 Purchasing Division  
 2019 Washington Street East  
 Post Office Box 50130  
 Charleston, WV 25305-0130

# Request for Quotation

RFQ NUMBER  
 GSD116457

PAGE  
 1

ADDRESS CORRESPONDENCE TO ATTENTION OF:  
 KRISTA FERRELL  
 304-558-2596

VENDOR

\*709053330      304-632-1558  
 DANHILL CONSTRUCTION COMPANY  
 PO BOX 685  
 GAULEY BRIDGE WV 25085

SHIP TO

DEPARTMENT OF ADMINISTRATION  
 GENERAL SERVICES DIVISION  
 JOBSITE  
 SEE SPECIFICATIONS  
 304-558-2317

DATE PRINTED	TERMS OF SALE	SHIP VIA	F.O.B.	FREIGHT TERMS
06/16/2011				

BID OPENING DATE: 06/30/2011      BID OPENING TIME: 01:30PM

LINE	QUANTITY	UOP	CAT NO	ITEM NUMBER	UNIT PRICE	AMOUNT
				ADDENDUM NO. 1		
				THIS ADDENDUM IS ISSUED TO:		
				1.) PROVIDE A COPY OF THE MANDATORY PRE-BID ATTENDEE LIST AND		
				2.) PROVIDE TECHNICAL SPECIFICATION CLARIFICATIONS PER THE ATTACHED		
				BID OPENING DATE REMAINS: 06/30/2011		
				BID OPENING TIME REMAINS: 1:30 PM		
				***** END ADDENDUM NO. 1 *****		
0001	1	LS		968-42		
				CAPITOL CAMPUS CONCRETE REPAIRS		
				***** THIS IS THE END OF RFQ GSD116457 *****		
				TOTAL:		\$ 258,900. <sup>00</sup>

SEE REVERSE SIDE FOR TERMS AND CONDITIONS

SIGNATURE: *Robert D. Hill*      TELEPHONE: 632-1600      DATE: 6/30/2011

TITLE: *President*      FEIN: 55-0648251      ADDRESS CHANGES TO BE NOTED ABOVE

WHEN RESPONDING TO RFQ, INSERT NAME AND ADDRESS IN SPACE ABOVE LABELED 'VENDOR'

#### GSD116457 Technical Specification Clarification

Changes to the Technical Specifications and Drawing Detail section of the RFQ:

4. Culture Center, North Parking Lot side walk and curb (change): Contractor shall cut out and replace **35 feet** of curbing as marked instead of 2 feet as indicated in the specification. The rest of detail #4 will remain the same as specified in the RFQ.
5. Greenbrier Street, Governor's Drive Entrance (addition): The Contractor shall remove and replace approximately 32 feet of curbing **and the deteriorated ADA ramp section on the South side** as indicted by red field marking. The rest of detail #5 will remain the same as specified in the RFQ.
11. Sidewalk area(s) adjacent to Bldg 5. Bldg 3 and former Fountain Circle south of Bldg 5: Remove and re-install 65 blocks in various areas of the walkway as indicated by field markings. Estimated at 2350 square feet.

Landscape restoration shall be the responsibility of the successful Contractor.

**BID BOND**

KNOW ALL MEN BY THESE PRESENTS, That we, the undersigned, Danhill Construction Company  
of Gauley Bridge, West Virginia, as Principal, and Colonial Surety Co. of  
Montvale, New Jersey, a corporation organized and existing under the laws of the State of NJ with its  
principal office in the City of Montvale, as Surety, are held and firmly bound unto the State of West Virginia, as Obligee, in the  
penal sum of 5 % Of Bid Amount (\$ 5% ) for the payment of which, well and truly to be made, we jointly and  
severally bind ourselves, our heirs, administrators, executors, successors and assigns.

The Condition of the above obligation is such that whereas the Principal has submitted to the Purchasing Section of the  
Department of Administration a certain bid or proposal, attached hereto and made a part hereof, to enter into a contract in writing for  
Capitol Complex concrete repairs

NOW THEREFORE,

(a) If said bid shall be rejected, or  
(b) If said bid shall be accepted and the Principal shall enter into a contract in accordance with the bid or proposal attached  
hereto and shall furnish any other bonds and insurance required by the bid or proposal, and shall in all other respects perform the  
agreement created by the acceptance of said bid, then this obligation shall be null and void, otherwise this obligation shall remain in full  
force and effect. It is expressly understood and agreed that the liability of the Surety for any and all claims hereunder shall, in no event,  
exceed the penal amount of this obligation as herein stated.

The Surety, for the value received, hereby stipulates and agrees that the obligations of said Surety and its bond shall be in no  
way impaired or affected by any extension of the time within which the Obligee may accept such bid, and said Surety does hereby  
waive notice of any such extension.

IN WITNESS WHEREOF, Principal and Surety have hereunto set their hands and seals, and such of them as are corporations  
have caused their corporate seals to be affixed hereunto and these presents to be signed by their proper officers, this  
30th day of June, 20 11.

Principal Corporate Seal

Danhill Construction Company  
(Name of Principal)

By Robert D. Hill *Robert D. Hill*  
(Must be President or  
Vice President)

President  
(Title)

Surety Corporate Seal

Colonial Surety company  
(Name of Surety)

Roberta Bird *Roberta Bird*  
Attorney-in-Fact

**IMPORTANT – Surety executing bonds must be licensed in West Virginia to transact surety insurance. Raised corporate seals  
must be affixed, a power of attorney must be attached.**

**Colonial Surety Company**

Administrative Office  
50 Chestnut Ridge Road  
Montvale, NJ 07645

**CONSENT OF SURETY**

State of West Virginia  
2019 Washington Street  
Charleston, WV 25305

RE: **Capitol Complex concrete repairs**

COLONIAL SURETY COMPANY organized and existing under the laws of the Commonwealth of Pennsylvania and duly qualified to transact business in the State of WV hereby agrees that **Danhill Construction Company Gauley Bridge, WV** has submitted a proposal on the captioned project. We hereby agree that in the event an award is made to **Danhill Construction Company Gauley Bridge, WV** that we will provide the required performance, payment and/or maintenance bonds.

Signed and sealed this 30th day of June 2011.

**COLONIAL SURETY COMPANY**

BY: Roberta Bird  
Roberta Bird (Attorney-in-Fact)

COLONIAL SURETY COMPANY

Duncannon, Pennsylvania
Administrative Office: 50 Chestnut Ridge Road, Montvale, New Jersey 07645

GENERAL POWER OF ATTORNEY

Know all Men by These Presents, That COLONIAL SURETY COMPANY, a corporation duly organized and existing under the laws of the Commonwealth of Pennsylvania and having an administrative office in Montvale, Bergen County, NJ does by these presents make, constitute and appoint

WV Wayne Nunziata or Anthony J. Cimasko or Audie B. Murphy
Robert Bird Gauley Bridge

of Montvale and the State of New Jersey its true and lawful Attorney(s)-in-Fact, with full power and authority hereby conferred in its name, place and stead, to execute, acknowledge and deliver.

Any and All Bonds

and to bind the Company thereby as fully and to the same extent as if such bonds were signed by the President, sealed with the corporate seal of the Company and duly attested by its Secretary, hereby ratifying and confirming all that the said Attorney(s)-in-Fact may do in the premises. Said appointment is made under and by authority of the following resolution adopted by the Board of Directors of the Colonial Surety Company at a meeting held on the 25th day of July, 1950.

Be it Resolved, that the President, any Vice-President, any Secretary or any Assistant Secretary shall be and is hereby vested with full power and authority to appoint any one or more suitable persons as Attorney(s)-in-Fact to represent and act for and on behalf of the Company subject to the following provisions:

Section 1. Attorney-in-Fact. Attorney-in-Fact may be given full power and authority for and in the name of and on behalf of the Company, to execute, acknowledge and deliver, any and all bonds, recognizances, contracts, agreements of indemnity and other conditional or obligatory undertakings and any and all notices and documents canceling or terminating the Company's liability thereunder, and any such instruments so executed by any such Attorney-in-Fact shall be binding upon the Company as if signed by the President and sealed and attested by the Corporate Secretary.

In Witness Whereof, Colonial Surety Company has caused these presents to be signed by its President and its corporate seal to be hereto affixed the 27th day of April, A.D., 2011.

COLONIAL SURETY COMPANY

State of New Jersey
County of Bergen
} SS.:



By Wayne Nunziata, President

On this 27th day of April, in the year 2011, before me Theresa Simmons, a notary public, personally appeared Wayne Nunziata, personally known to me to be the person who executed the within instrument as President, on behalf of the corporation therein named and acknowledged to me that the corporation executed it.



THERESA SIMMONS
A Notary Public of New Jersey
My Commission Expires September 9, 2015

Theresa Simmons, Notary Public

I, the undersigned Secretary of Colonial Surety Company, hereby certify that the above and foregoing is a full, true and correct copy of the Original Power of Attorney issued by said Company, and do hereby further certify that the said Power of Attorney is still in force and effect.

And I do hereby further certify that the Certification of this Power of Attorney is signed and sealed by facsimile under and by the authority of the following resolution adopted by the Board of Directors of the Colonial Surety Company at a meeting duly called and held on the 30th of January 1968, and that said resolution has not been amended or repealed:

RESOLVED, that the signature of the Secretary or any Assistant Secretary of this Corporation, and the seal of Corporation, may be affixed or printed by facsimile to any certificate to a Power of Attorney of this Corporation, and that such printed facsimile signature and seal shall be valid and binding upon this Corporation.

GIVEN under my hand and the seal of said Company, at Montvale, New Jersey this 30th day of June, 2011.

For verification of the authenticity of this Power of Attorney you may call (201) 573-8788 and ask for the Power of Attorney clerk. Please refer to the above named individual(s) and details of the bond to which the power is attached.

Audie B. Murphy, Secretary

State of West Virginia  
County of Fayette

AND NOW, this 30th day of June, in the calendar year of 2011, before me, a duly appointed and commissioned notary public, came the identified subscriber to the within instrument or instruments, and/or the demonstrated attorney-in-fact for said signatory and subscriber on said instrument or instruments, **Roberta Bird, attorney-in-fact of Colonial Surety Company**, an insurance company duly organized and existing under the laws of the Commonwealth of Pennsylvania and which is authorized to conduct business in this State, and that as such being authorized to do so, acknowledged that the within instrument or instruments were executed as the authorized act of his disclosed principal for the purposes therein contained, and declared to be a person executing said instrument or instruments as attorney-in-fact and with full capacity and competency, at the request of and on behalf of Colonial Surety Company therein named and acknowledged to me that the aforesaid Colonial Surety Company had authorized the execution by the aforesaid attorney-in-fact of said instrument or instruments with the intent to be legally bound as required by common and statutory law.

IN WITNESS WHEREOF, I hereunto set my hand and official seal.

A Notary Public of West Virginia  
My Commission Expires on 3/28/2015

Notary Public in and for the

County of Fayette  
State of West Virginia

