



State of West Virginia
 Department of Administration
 Purchasing Division
 2019 Washington Street East
 Post Office Box 50130
 Charleston, WV 25305-0130

Request for Quotation

RFQ NUMBER
DPS1139

PAGE
1

ADDRESS CORRESPONDENCE TO ATTENTION OF
TARA LYLE
304-558-2544

VENDOR

*416114213 800-949-7079
TALLEY INC
12976 SANDOVAL ST

SANTA FE SPRINGS CA 90670

SHIP TO

WEST VIRGINIA STATE POLICE

4124 KANAWHA TURNPIKE
SOUTH CHARLESTON, WV
25309 304-746-2141

DATE PRINTED	TERMS OF SALE	SHIP VIA	F.O.B.	FREIGHT TERMS
05/20/2011				

BID OPENING DATE: **05/31/2011** BID OPENING TIME: **01:30PM**

LINE	QUANTITY	UOP	CAT NO	ITEM NUMBER	UNIT PRICE	AMOUNT
ADDENDUM NO. 1						
1. QUESTIONS AND ANSWERS ARE ATTACHED. 2. TO MOVE THE BID OPENING DATE FROM 05/24/2011 TO 5/31/2011 3. ADDENDUM ACKNOWLEDGEMENT IS ATTACHED. THIS DOCUMENT SHOULD BE SIGNED AND RETURNED WITH YOUR BID. FAILURE TO SIGN AND RETURN MAY RESULT IN DISQUALIFICATION OF YOUR BID.						
END OF ADDENDUM NO. 1						
0001	1	LS		725-12		
	ANTENNAS, RADIO					
***** THIS IS THE END OF RFQ DPS1139 ***** TOTAL:						<u>27,233²⁰</u>

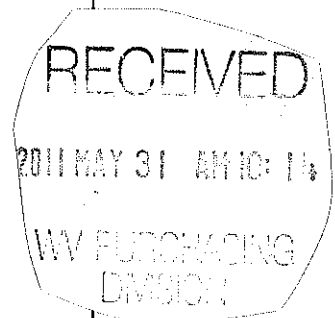

SEE REVERSE SIDE FOR TERMS AND CONDITIONS

SIGNATURE	TELEPHONE	DATE
<i>[Signature]</i>	562-9068065	5/27/11
TITLE	ADDRESS CHANGES TO BE NOTED ABOVE	
Dir. E.M.R. Public Safety	95-387 2464	

WHEN RESPONDING TO RFQ, INSERT NAME AND ADDRESS IN SPACE ABOVE LABELED 'VENDOR'

DPS1139
ADDENDUM NO. 1

Q1: I have found an incorrect P/n: #2 CL-450B should read: CL6-450B.

A1: Line item #2 part # should be CL6-450B

Q2: WGK-C12 should be listed as Ea, not 10pk. Do you want 40pcs or 400?

A2: Line item #12 should be priced each and not as a 10 pack.

Q3: Item 16 204679A-7 is not a good P/n from Andrew. I can give you a 4" Boot w/ 3 x ½" holes (252147) and ½" plugs (294735 5pk) x 3.

A3: Line item #16 Andrews 204679A-7 has been discontinued and can be replaced with wireless solutions WS-B412-3 or equivalent.

***** The bid opening date has moved from 05/24/2011 to 05/31/2011.**

EXHIBIT 10

REQUISITION NO.: DS1139

ADDENDUM ACKNOWLEDGEMENT

I HEREBY ACKNOWLEDGE RECEIPT OF THE FOLLOWING CHECKED ADDENDUM(S) AND HAVE MADE THE NECESSARY REVISIONS TO MY PROPOSAL, PLANS AND/OR SPECIFICATION, ETC.

ADDENDUM NO.'S:

NO. 1 277

NO. 2

NO. 3

NO. 4

NO. 5

I UNDERSTAND THAT FAILURE TO CONFIRM THE RECEIPT OF THE ADDENDUM(S) MAY BE CAUSE FOR REJECTION OF BIDS. VENDOR MUST CLEARLY UNDERSTAND THAT ANY VERBAL REPRESENTATION MADE OR ASSUMED TO BE MADE DURING ANY ORAL DISCUSSION HELD BETWEEN VENDOR'S REPRESENTATIVES AND ANY STATE PERSONNEL IS NOT BINDING. ONLY THE INFORMATION ISSUED IN WRITING AND ADDED TO THE SPECIFICATIONS BY AN OFFICIAL ADDENDUM IS BINDING.



SIGNATURE

Talley

COMPANY

5/26/11

DATE



State of West Virginia
 Department of Administration
 Purchasing Division
 2019 Washington Street East
 Post Office Box 50130
 Charleston, WV 25305-0130

Request for Quotation

RFQ NUMBER
DPS1139

PAGE
1

ADDRESS CORRESPONDENCE TO ATTENTION OF
TARA LYLE
304-558-2544

RFQ COPY
 TYPE NAME/ADDRESS HERE

Talley
12976 Sandoval St
Santa Fe Springs, CA 90670
562-906-8000

WEST VIRGINIA STATE POLICE

4124 KANAWHA TURNPIKE
 SOUTH CHARLESTON, WV
 25309 304-746-2141

DATE PRINTED	TERMS OF SALE	SHIP VIA	F.O.B.	FREIGHT TERMS
04/19/2011	N-30	Best Way Ground	Origin	PP + A
BID OPENING DATE: 05/24/2011		BID OPENING TIME 01:30PM		

LINE	QUANTITY	UOP	CAT. NO.	ITEM NUMBER	UNIT PRICE	AMOUNT
0001	1	LS		725-12		
ANTENNAS, RADIO INQUIRIES: WRITTEN QUESTIONS WILL BE ACCEPTED UNTIL CLOSE OF BUSINESS ON 05/10/2011. QUESTIONS MAY BE SENT VIA USPS, FAX, COURIER AND E-MAIL. IN ORDER TO ASSURE NO VENDOR RECEIVES AN UNFAIR ADVANTAGE, NO SUBSTANTIVE QUESTIONS WILL BE ANSWERED ORALLY. IF POSSIBLE, E-MAIL QUESTIONS ARE PREFERRED. ADDRESS INQUIRIES TO: TARA LYLE DEPARTMENT OF ADMINISTRATION PURCHASING DIVISION 2019 WASHINGTON STREET, EAST CHARLESTON, WV 25305 FAX: 304-558-4115 E-MAIL: TARA.L.LYLE@WV.GOV EXHIBIT 3 LIFE OF CONTRACT: THIS CONTRACT BECOMES EFFECTIVE ON AWARD AND EXTENDS FOR A PERIOD OF ONE (1) YEAR OR UNTIL SUCH "REASONABLE TIME" THEREAFTER AS IS NECESSARY TO OBTAIN A NEW CONTRACT OR RENEW THE ORIGINAL CONTRACT. THE "REASONABLE TIME" PERIOD SHALL NOT EXCEED TWELVE (12) MONTHS. DURING THIS "REASONABL						

SEE REVERSE SIDE FOR TERMS AND CONDITIONS			
SIGNATURE <i>Larry Feig</i>	TELEPHONE 562-906-8065	DATE 5/27/11	
TITLE <i>Public Safety</i>	FAX 95-387 2464	ADDRESS CHANGES TO BE NOTED ABOVE	

WHEN RESPONDING TO RFQ, INSERT NAME AND ADDRESS IN SPACE ABOVE LABELED 'VENDOR'



State of West Virginia
 Department of Administration
 Purchasing Division
 2019 Washington Street East
 Post Office Box 50130
 Charleston, WV 25305-0130

Request for Quotation

RFQ NUMBER
DPS1139

PAGE
2

ADDRESS CORRESPONDENCE TO ATTENTION OF
TARA LYLE
304-558-2544

RFQ COPY

TYPE NAME/ADDRESS HERE

Talley

SHIP TO

WEST VIRGINIA STATE POLICE

4124 KANAWHA TURNPIKE
 SOUTH CHARLESTON, WV
 25309 304-746-2141

DATE PRINTED	TERMS OF SALE	SHIP VIA	FOB	FREIGHT TERMS		
04/19/2011						
BID OPENING DATE: 05/24/2011		BID OPENING TIME 01:30PM				
LINE	QUANTITY	UOP	CAT NO	ITEM NUMBER	UNIT PRICE	AMOUNT
<p>TIME" THE VENDOR MAY TERMINATE THIS CONTRACT FOR ANY REASON UPON GIVING THE DIRECTOR OF PURCHASING 30 DAYS WRITTEN NOTICE.</p> <p>UNLESS SPECIFIC PROVISIONS ARE STIPULATED ELSEWHERE IN THIS CONTRACT DOCUMENT, THE TERMS, CONDITIONS AND PRICING SET HEREIN ARE FIRM FOR THE LIFE OF THE CONTRACT.</p> <p>RENEWAL: THIS CONTRACT MAY BE RENEWED UPON THE MUTUAL WRITTEN CONSENT OF THE SPENDING UNIT AND VENDOR, SUBMITTED TO THE DIRECTOR OF PURCHASING THIRTY (30) DAYS PRIOR TO THE EXPIRATION DATE. SUCH RENEWAL SHALL BE IN ACCORDANCE WITH THE TERMS AND CONDITIONS OF THE ORIGINAL CONTRACT AND SHALL BE LIMITED TO TWO (2) ONE (1) YEAR PERIODS.</p> <p>CANCELLATION: THE DIRECTOR OF PURCHASING RESERVES THE RIGHT TO CANCEL THIS CONTRACT IMMEDIATELY UPON WRITTEN NOTICE TO THE VENDOR IF THE COMMODITIES AND/OR SERVICES SUPPLIED ARE OF AN INFERIOR QUALITY OR DO NOT CONFORM TO THE SPECIFICATIONS OF THE BID AND CONTRACT HEREIN.</p> <p>OPEN MARKET CLAUSE: THE DIRECTOR OF PURCHASING MAY AUTHORIZE A SPENDING UNIT TO PURCHASE ON THE OPEN MARKET, WITHOUT THE FILING OF A REQUISITION OR COST ESTIMATE, ITEMS SPECIFIED ON THIS CONTRACT FOR IMMEDIATE DELIVERY IN EMERGENCIES DUE TO UNFORESEEN CAUSES (INCLUDING BUT NOT LIMITED TO DELAYS IN TRANSPORTATION OR AN UNANTICIPATED INCREASE IN THE VOLUME OF WORK.)</p> <p>QUANTITIES: QUANTITIES LISTED IN THE REQUISITION ARE APPROXIMATIONS ONLY, BASED ON ESTIMATES SUPPLIED BY THE STATE SPENDING UNIT. IT IS UNDERSTOOD AND AGREED THAT THE CONTRACT SHALL COVER THE QUANTITIES ACTUALLY</p>						
SEE REVERSE SIDE FOR TERMS AND CONDITIONS						
SIGNATURE			TELEPHONE		DATE	
TITLE		FEIN		ADDRESS CHANGES TO BE NOTED ABOVE		

WHEN RESPONDING TO RFQ, INSERT NAME AND ADDRESS IN SPACE ABOVE LABELED 'VENDOR'



State of West Virginia
 Department of Administration
 Purchasing Division
 2019 Washington Street East
 Post Office Box 50130
 Charleston, WV 25305-0130

Request for Quotation

RFC NUMBER
DPS1139

PAGE
3

ADDRESS CORRESPONDENCE TO ATTENTION OF
TARA LYLE 304-558-2544

VENDOR

RFQ COPY
 TYPE NAME/ADDRESS HERE

Talley

SHIP TO

WEST VIRGINIA STATE POLICE

4124 KANAWHA TURNPIKE
 SOUTH CHARLESTON, WV
 25309 304-746-2141

DATE PRINTED	TERMS OF SALE	SHIP VIA	F.O.B.	FREIGHT TERMS
04/19/2011				
BID OPENING DATE: 05/24/2011		BID OPENING TIME 01:30PM		

LINE	QUANTITY	UOP	CAT NO.	ITEM NUMBER	UNIT PRICE	AMOUNT
<p>ORDERED FOR DELIVERY DURING THE TERM OF THE CONTRACT, WHETHER MORE OR LESS THAN THE QUANTITIES SHOWN.</p> <p>ORDERING PROCEDURE: SPENDING UNIT(S) SHALL ISSUE A WRITTEN STATE CONTRACT ORDER (FORM NUMBER WV-39) TO THE VENDOR FOR COMMODITIES COVERED BY THIS CONTRACT. THE ORIGINAL COPY OF THE WV-39 SHALL BE MAILED TO THE VENDOR AS AUTHORIZATION FOR SHIPMENT, A SECOND COPY MAILED TO THE PURCHASING DIVISION, AND A THIRD COPY RETAINED BY THE SPENDING UNIT.</p> <p>BANKRUPTCY: IN THE EVENT THE VENDOR/CONTRACTOR FILES FOR BANKRUPTCY PROTECTION, THE STATE MAY DEEM THE CONTRACT NULL AND VOID, AND TERMINATE SUCH CONTRACT WITHOUT FURTHER ORDER.</p> <p>THE TERMS AND CONDITIONS CONTAINED IN THIS CONTRACT SHALL SUPERSEDE ANY AND ALL SUBSEQUENT TERMS AND CONDITIONS WHICH MAY APPEAR ON ANY ATTACHED PRINTED DOCUMENTS SUCH AS PRICE LISTS, ORDER FORMS, SALES AGREEMENTS OR MAINTENANCE AGREEMENTS, INCLUDING ANY ELECTRONIC MEDIUM SUCH AS CD-ROM.</p> <p>REV. 05/26/2009</p> <p>THE MODEL/BRAND/SPECIFICATIONS NAMED HEREIN ESTABLISH THE ACCEPTABLE LEVEL OF QUALITY ONLY AND ARE NOT INTENDED TO REFLECT A PREFERENCE OR FAVOR ANY PARTICULAR BRAND OR VENDOR. VENDORS WHO ARE BIDDING ALTERNATES SHOULD SO STATE AND INCLUDE PERTINENT LITERATURE AND SPECIFICATIONS. FAILURE TO PROVIDE INFORMATION FOR ANY ALTERNATES MAY BE GROUNDS FOR REJECTION OF THE BID. THE STATE RESERVES THE RIGHT TO WAIVE MINOR IRREGULARITIES IN BIDS OR SPECIFICATIONS IN ACCORDANCE WITH SECTION 148-1-4(F) OF THE WEST VIRGINIA LEGISLATIVE RULES AND REGULATIONS.</p>						

SEE REVERSE SIDE FOR TERMS AND CONDITIONS			
SIGNATURE	TELEPHONE	DATE	
TITLE	FEIN	ADDRESS CHANGES TO BE NOTED ABOVE	

WHEN RESPONDING TO RFQ, INSERT NAME AND ADDRESS IN SPACE ABOVE LABELED 'VENDOR'



State of West Virginia
 Department of Administration
 Purchasing Division
 2019 Washington Street East
 Post Office Box 50130
 Charleston, WV 25305-0130

Request for Quotation

RFQ NUMBER
DPS1139

PAGE
4

ADDRESS CORRESPONDENCE TO ATTENTION OF
**TARA LYLE
 304-558-2544**

VENDOR

RFQ COPY
 TYPE NAME/ADDRESS HERE

Talley

SHIP TO

WEST VIRGINIA STATE POLICE

**4124 KANAWHA TURNPIKE
 SOUTH CHARLESTON, WV
 25309 304-746-2141**

DATE PRINTED	TERMS OF SALE	SHIP VIA	FOB	FREIGHT TERMS		
04/19/2011						
BID OPENING DATE: 05/24/2011		BID OPENING TIME 01:30PM				
LINE	QUANTITY	UOP	CAT NO	ITEM NUMBER	UNIT PRICE	AMOUNT
<p>EXHIBIT 4</p> <p>LOCAL GOVERNMENT BODIES: UNLESS THE VENDOR INDICATES IN THE BID HIS REFUSAL TO EXTEND THE PRICES, TERMS, AND CONDITIONS OF THE BID TO COUNTY, SCHOOL, MUNICIPAL AND OTHER LOCAL GOVERNMENT BODIES, THE BID SHALL EXTEND TO POLITICAL SUBDIVISIONS OF THE STATE OF WEST VIRGINIA. IF THE VENDOR DOES NOT WISH TO EXTEND THE PRICES, TERMS, AND CONDITIONS OF THE BID TO ALL POLITICAL SUBDIVISIONS OF THE STATE, THE VENDOR MUST CLEARLY INDICATE SUCH REFUSAL IN HIS BID. SUCH REFUSAL SHALL NOT PREJUDICE THE AWARD OF THIS CONTRACT IN ANY MANNER.</p> <p>REV. 3/88</p> <p>PURCHASING CARD ACCEPTANCE: THE STATE OF WEST VIRGINIA CURRENTLY UTILIZES A VISA PURCHASING CARD PROGRAM WHICH IS ISSUED THROUGH A BANK. THE SUCCESSFUL VENDOR MUST ACCEPT THE STATE OF WEST VIRGINIA VISA PURCHASING CARD FOR PAYMENT OF ALL ORDERS PLACED BY ANY STATE AGENCY AS A CONDITION OF AWARD.</p> <p>VENDOR PREFERENCE CERTIFICATE</p> <p>THIS TEAM EXHIBIT HAS BEEN REPLACED BY THE ONLINE VERSION WHICH IS AVAILABLE HERE: HTTP://WWW.STATE.WV.US/ADMIN/PURCHASE/VRC/VENPREF.PDF</p> <p>NOTICE</p> <p>A SIGNED BID MUST BE SUBMITTED TO: DEPARTMENT OF ADMINISTRATION</p>						
SEE REVERSE SIDE FOR TERMS AND CONDITIONS						
SIGNATURE			TELEPHONE		DATE	
TITLE		FED		ADDRESS CHANGES TO BE NOTED ABOVE		

WHEN RESPONDING TO RFQ, INSERT NAME AND ADDRESS IN SPACE ABOVE LABELED 'VENDOR'



State of West Virginia
 Department of Administration
 Purchasing Division
 2019 Washington Street East
 Post Office Box 50130
 Charleston, WV 25305-0130

Request for Quotation

RFQ NUMBER
DPS1139

PAGE
5

ADDRESS CORRESPONDENCE TO ATTENTION OF
**TARA LYLE
 304-558-2544**

PURCHASER

RFQ COPY
 TYPE NAME/ADDRESS HERE

SHIP TO

WEST VIRGINIA STATE POLICE

**4124 KANAWHA TURNPIKE
 SOUTH CHARLESTON, WV
 25309 304-746-2141**

DATE PRINTED	TERMS OF SALE	SHIP VIA	F.O.B.	FREIGHT TERMS
04/19/2011				

BID OPENING DATE: **05/24/2011** BID OPENING TIME **01:30PM**

LINE	QUANTITY	UOP	CAT. NO.	ITEM NUMBER	UNIT PRICE	AMOUNT
PURCHASING DIVISION BUILDING 15 2019 WASHINGTON STREET, EAST CHARLESTON, WV 25305-0130						
THE BID SHOULD CONTAIN THIS INFORMATION ON THE FACE OF THE ENVELOPE OR THE BID MAY NOT BE CONSIDERED:						
SEALED BID						
BUYER:-----TL/32-----						
RFQ. NO.:-----DPS1139-----						
BID OPENING DATE:-----05/24/2011-----						
BID OPENING TIME:-----1:30 PM-----						
PLEASE PROVIDE A FAX NUMBER IN CASE IT IS NECESSARY TO CONTACT YOU REGARDING YOUR BID:						
-----562-906-8080 <i>lfeige@talliej.com.com</i> -----						
CONTACT PERSON (PLEASE PRINT CLEARLY):						
----- <i>Larry Feige</i> -----						

SEE REVERSE SIDE FOR TERMS AND CONDITIONS

SIGNATURE	TELEPHONE	DATE
-----------	-----------	------

TITLE	FEIN	ADDRESS CHANGES TO BE NOTED ABOVE.
-------	------	------------------------------------

WHEN RESPONDING TO RFQ, INSERT NAME AND ADDRESS IN SPACE ABOVE LABELED 'VENDOR'

SPECIFICATIONS FOR RF CABLE, CONNECTORS, ANTENNAS AND ACCESSORIES

DPS1139

The West Virginia State Police (WVSP) is requesting competitive bids for RF Cable, connectors, antennas, and accessories as per the attached specifications. The contract shall be available for use by all other entities of state government, as well as counties and municipalities.

All items bid must meet or exceed the manufacture/part numbers listed. If a vendor bids a product which does not meet the specifications of an item, but they believe exceeds the specifications then the vendor is required to submit their exceptions in writing specifically listing the item and line-specification(s) they are taking exception to. Vendors shall submit within seven days upon request, a product sheet for each item bid, which is to include at a minimum: picture, manufacturer, model number, and general specifications for the item.

Award:

The purchase order will be awarded to one (1) vendor with the most complete bid with the lowest grand total meeting all of the specifications.

**DPS1139
BID FORM**

LINE ITEM	ITEM	Manufacturer/Part Number	Description	QTY	Cost per unit	Total cost	
1	Antenna	Comprod 532-70, or equal	Heavy Duty Exposed Folded Dipole Array, Dual Configuration, Low Band - 42.06 Mhz	2	1642 ³³	3284 ⁶⁶	✓
2	Antenna	Scala CL-450B, or equal	Antenna, UHF Broadband Log-periodic Fixed-station	4	495 ⁻	1980 ⁻	✓
3	Bracket	Comprod 115-85, or equal	Mounting Clamp, 90 Degree Pipe to Pipe, 1.5" - 3.5" to 1.5" - 3.5"	4	48 ⁻	192 ⁻	✓
4	Bracket	Kathrein-Scala 131-1847, or equal	Band Clamp, 2" - 6"	4	3 ⁷⁵	15 ⁻	✓
5	Bracket	Kathrein-Scala MKPS-1, or equal	Mounting Clamp, Fits 2.375" OD Mast, w/ 90 Degree Angle	4	50 ⁻	200 ⁻	✓
6	Feedline	Andrews LDF4-50A, or equal	Cable, 1/2" Heliax Hardline, 500 Foot Roll	5	1.68	4200 ⁻	✓
7	Connector	Andrews L4PNF, or equal	RF Connector, N - Female, Silver plate/Gold Center pin, for LDF4-50A	60	15 ⁹⁸	958 ⁸⁰	✓
8	Connector	RF Industries L44U, or equal	RF Connector, Captivated UHF - Female, for LDF4-50A	30	24 ⁷⁵	742 ⁵⁰	*✓
9	Connector	Amphenol 83-1SP-1050, or equal	RF Connector, PL-259, Teflon insulator	250	2 ⁸⁶	715 ⁻	✓
10	Connector	RFS 738803, or equal	RF Connector, Field Repair UHF - Female, Captivated, Silver/Brass, for LDF4-50A	10	24 ⁷⁵	247 ⁵⁰	*✓
11	Hangers	Wireless Solutions WSSH-U12, or equal	Hanger Clips, Stackable, for 1/2" Hardline, 10 Pk.	50	18 ⁵⁰	925 ⁻	*✓
12	Grounding Kits	Wireless Solutions WGK-C12, or equal	Clip-on Ground kit, for 1/2" Hardline, 10 Pk.	40	11 ²⁵	450 ⁻	*✓
13	Tape	3M Super 33+ 054007-06132, or equal	Electrical Tape, Premium Vinyl, 10 Pk. 3/4" x 66'	12	38 ⁶⁰	463 ²⁰	✓
14	Feedline	Belden 8214, or equal	Cable, Braided Coax, 50 Ohms, 1000 foot Roll	5	1670 ⁻	7850 ⁻	✓
15	Connector	RF Industries RFN-1001-S, or equal	RF Connector, N - Male, Clamp/Solder, for 8214 cable	60	4 ⁶⁰	276 ⁻	✓
16	Boots	Andrews 204679A-7, or equal	Entry Boot, 4" w/ (3) 1/2" Hardline Holes and Plugs	15	15 ⁷⁶	236 ⁴⁰	*✓
17	Coax Protector	Polyphaser IS-B50HN-C1-MA, or equal	Bulkhead Mount, 50-700 Mhz, N-Female (Equipment End), N-Male (Antenna End)	20	48 ⁶⁰	972 ⁰⁰	✓
18	Coax Protector	Polyphaser IS-B50HN-CO-MA, or equal	Bulkhead Mount, 1.5 - 400 Mhz, N-Female (Equipment End), N-Male (Antenna End)	20	48 ⁶⁰	972 ⁻	✓
19	Coaxial Adapter	RF Industries RFN-1035-1, or equal	Braided Coax Adapter, N-Male to UHF-Female	20	5 ¹⁰	102 ⁻	✓
20	Coaxial Adapter	Emerson Network Power 26-8014, or equal	Braided Coax Adapter, N-Female to UHF-Male	20	4 ¹⁰	82 ⁻	*✓

21	Coaxial Adapter	RF Industries RFN-1014-1, or equal	Braided Coax Adapter, N-Male to N-Male	20	6 ¹⁵	123 ⁸ ✓
22	Coaxial Adapter	RF Industries RFU-538, or equal	Braided Coax Adapter, UHF-Male to UHF-Male	20	3 ³⁰	66 ⁻ ✓
23	Coaxial Adapter	RF Industries RFN-1013-1, or equal	Braided Coax Adapter, N-Female to N-Female	20	4 ³⁵	87 ⁻ ✓
24	Coaxial Adapter	RF Industries RFU-536, or equal	Braided Coax Adapter, UHF-Female to UHF-Female	20	1 ⁷⁰	34 ⁻ ✓
25	Clamp	Andrews AB-S50-SSH, or equal	Tapered Leg Pipe-to-Pipe Clamp, Joins 1-1/2" - 3-1/2" OD pipe to 2-3/8" - 5" OD pipe.	12	111 ⁵⁴	1338 ⁹⁸ ✓
26	Clamp	Andrews BC-30-10, or equal	Tapered Leg Pipe-to-Pipe Clamp, Joins two 1-1/2" to 3-1/2" OD round members	12	46 ⁵⁸	558 ⁹⁶ ✓
27	Wire	Wireless Solutions 6-19G, or equal	Ground Wire, #6 AWG 19-Strand, Green Insulation, 250 feet	1	162 ⁵⁰	162 ⁵⁰ *

GRAND TOTAL: 27,233²⁰

NOTE: All quantities specified in the Price Quotation form are for bid purposes only. Actual quantities to be purchased may vary with each order.

Failure to use this information may result in disqualification.

Bidder / Vendor Information:

Company Name:

~~Larry~~ ²⁷⁷ Talley

Address:

12976 Sandoval St SFS, CA 90670

Contact Name:

Larry Feige

Phone No.:

562-906-8065

Fax No.:

562-906-8080

lfeige@talleycom.com

✓ = quoted
 * = quoted alternative equal see exception list.



You Connect the World. We Make it Easy.

5/26/11

State of West Virginia – DOA
DPS1139

List of Exceptions:

Item #	P/n	Reason for taking exception
8	RFU520H1	Although RF Connector was specified, no P/n was listed
10	UHFF-LCF12-001	This is the current P/n = 738803
11	SSH-12	Andrew equivalent to WSSH-U12 (Tessco proprietary #)
12	294500	I-Line (Andrew) Equiv. To WGK-C12 (“ “ “)
16	252147	As per addendum #1
20	RFN1036-1	Equivalent to Emerson Network 26-8014
27	MT586G	Equivalent to WS 6-19G (Tessco Proprietary #)

Please contact Larry Feige with any questions: P 562-906-8065, F 562-906-8080,
E lfeige@talleycom.com



A Division of RF Industries

UHF Connectors for Heliax®

Heliax is a registered trademark of Andrew Corporation

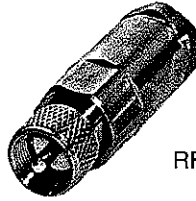

RFU-502-H1

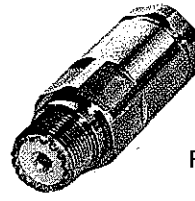

RFU-520-H1

Tools and Materials Required for Assembly

- File, flat or RFA-4420 Cable Devil
- Wrench: (2) 13/16 in
- Razor Knife
- Hacksaw, fine-toothed blade
- Wire brush, small
- Silicone grease

Read Instructions Thoroughly Before Assembly

Step 1. Prepare Cable. End of cable must be straight for at least 10 in (254mm). Remove jacket to approximate dimension shown. Use knife. Deburr sharp end of cut outer conductor.

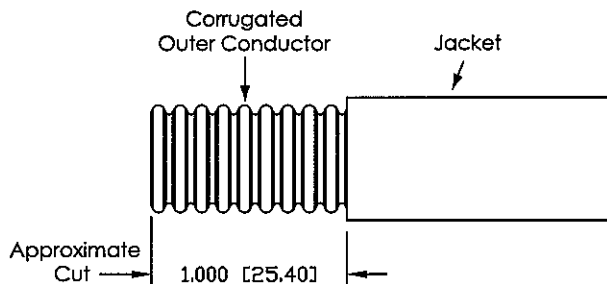

Step 2. Make second jacketing cut. Scribe line on ridge of exposed corrugated outer conductor. Line must be at least 13/32 in (10mm) from end of cable. Remove jacket to dimension shown using straight-edged piece of heavy paper wrapped around cable to guide cut.

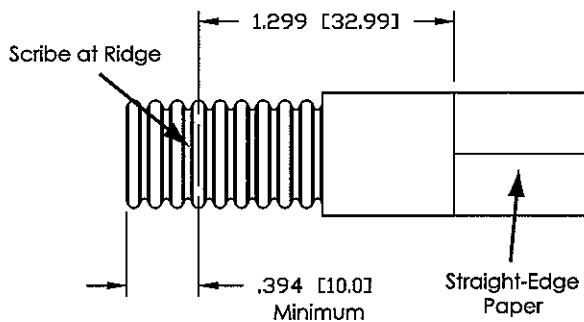

Step 3. Install gasket. Add thin O-ring gasket to second fully-exposed corrugation groove from jacket. Apply thin coating of silicone grease to outer surface of gasket and gasket lead chamfer in clamping nut using finger tip. Do not allow silicone grease on threads of clamping nut.

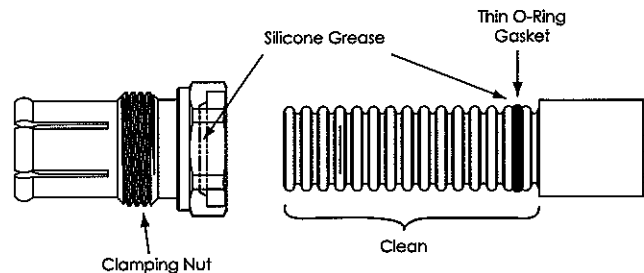

Step 4. Add clamping nut and cut cable. Push clamping nut on cable. Use twisting motion to assure spring contacts snap into groove. Refer to cutaway view in Step 6. Grip clamping nut with one hand and align edge with scribed line. Then carefully cut outer conductor and foam dielectric material flush with end of clamping nut, exposing center conductor. Make shallow cut; do not damage center conductor. Use hacksaw with fine-toothed blade or model maker's saw.

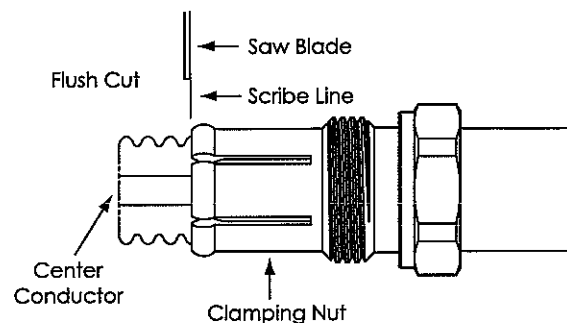

Continued on back →

Step 5. Trim center conductor. Cut center conductor to length shown. Use file to deburr cut end of center conductor.

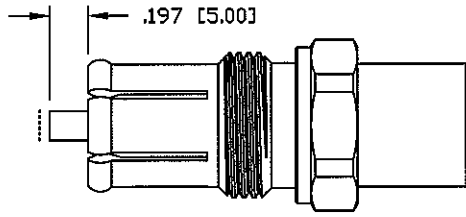

Step 6. Detach foam dielectric. Separate all foam dielectric completely from edge of outer conductor to assure good electrical contact with outer body. Refer to enlarged cutaway view in Step 7 which illustrates positive grip of outer conductor between clamping nut and outer body. Use tip of knife and work around entire circumference. Remove burrs from inside edge of outer conductor with knife. Use wire brush to remove copper particles from foam.

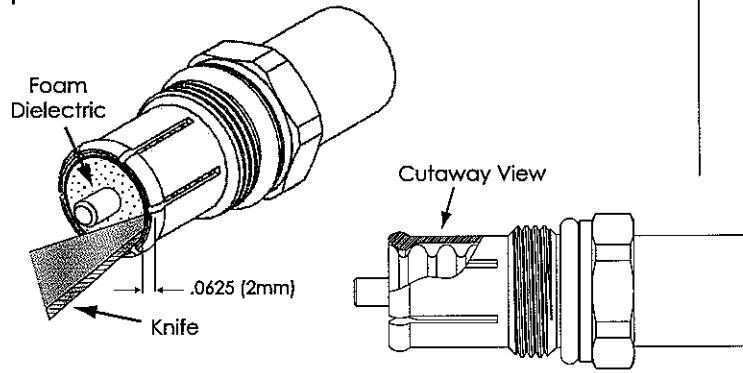

Step 7. Inspect contact surface. Thread outer body to clamping nut and tighten with wrenches. Turn outer body only; do not turn clamping nut. Disassemble connection to inspect for good metal-to-metal contact of flared outer conductor.

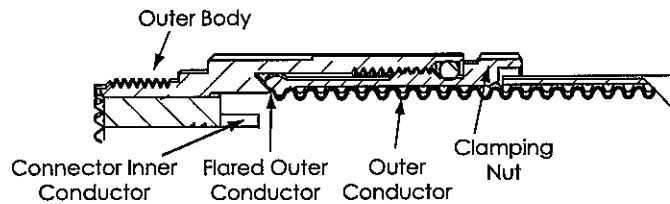

Step 8. Tighten clamp nut to outer body. Place thick O-ring gasket into groove in clamping nut. Add thin coating of silicone grease to outer surface of gasket. Do not allow silicone grease on threads of clamping nut. Slip the cable center conductor into connector inner conductor inside the outer body. Make certain connector is straight, i.e., square to flared outer conductor thread outer body onto clamping nut and tighten. Turn outer body only; do not turn clamping nut.

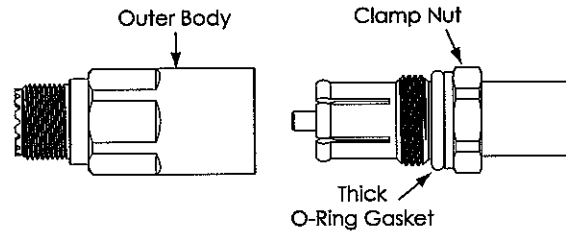



UHF Female Connector for 1/2" Coaxial Cable, Straight O-ring sealing, Brass/Silver

Product Description

Radio Frequency Systems' line of high performance coaxial cable connectors are designed specifically to provide the highest quality connector-cable interface while simplifying and speeding up the attachment of connectors to CELLFLEX® coaxial cables. RFS connectors are fully tested for mechanical and electrical compliance specifications. They are available in all popular cable sizes in a variety of mating interfaces.

Features/Benefits

- **Waterproof**

The only totally waterproof connector in the industry. Compliant with IP68 water immersion testing. Press fit contact/bead O-ring keeps out moisture and prevents vacuum build-up and air exchange due to temperature swings.

- **Solderless**

Captivated spring finger contacts permit quick, easy and precise solderless installation utilizing only basic hand tools. Avoids the potential high impedance risk associated with traditional soldering.

- **Self Flaring**

Self flaring design reduces installation time and thus, saves on labor costs.

- **Corrosion-Proof Plated Contacts**

Featured even on standard connectors. Provide improved contact resistance and lower intermodulation.

- **Outstanding Electrical Performance**

Metal to Metal contact between cable and connector - no plastic parts used. Secure connection highly resistant to pull-off or twist-off provides long-term mechanical integrity. Resistant to intermodulation after temperature cycling.

- **Easy to Install**

No special tools needed. Only basic hand tools required. No additional costs to the installer.

Technical Specifications

Transmission Line Type	Coaxial Cable
Cable Size	1/2"
Cable Type	Foam Dielectric, Air Dielectric
Model Series	LCF12-50 Series / ICA12-50 Series
Connector Interface	UHF
Connector Type	Straight
Sealing Method	O-ring
Gender	Female
Plating Outer/Inner	Brass/Silver
Length, mm (in)	81.3 (3.2)
Outer Diameter, mm (in)	25.4 (1.0)
Weight, kg (lb)	0.18 (0.40)
Inner Contact Attachment	Basket
Outer Contact Attachment	Self Flare
Wrench size front, mm (in)	24 (15/16)
Wrench size rear, mm (in)	21 (7/8)
Trimming Tool	TRIM-Series-B

Notes

Other Documentation

All information contained in the present datasheet is subject to confirmation at time of ordering.

Product Specifications



SSH-12

SnapStak® Hanger for 1/2 in coaxial cable

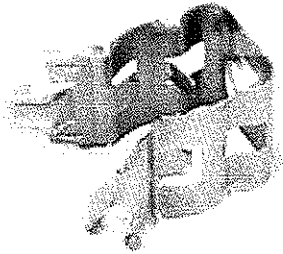

CHARACTERISTICS

Dimensions

Nominal Size	1/2 in
Compatible Diameter, maximum	16.256 mm 0.640 in
Compatible Diameter, minimum	13.716 mm 0.540 in
Height	41.00 mm 1.61 in
Length	66.00 mm 2.60 in
Width	22.80 mm 0.90 in

Electrical Specifications

DTF Effect	0.1 dB
Return Loss Effect	0.1 dB

General Specifications

Hanger Type	Snap-in hanger
Cables Per Hanger	1
Color	Silver
Material Type	Stainless steel
Maximum Stack Height	3
Package Quantity	10

Mechanical Specifications

Axial Load Capability, minimum with no cable slippage	≥5 times cable weight
Corrosion Resistance, minimum with no degradation	≥500 hours in salt spray chamber
Mounting	3/4 in drilled cable ladder
Operating Temperature	-40 °C to +85 °C (-40 °F to +185 °F)

www.commscope.com/andrew

©2011 CommScope, Inc. All rights reserved.
All trademarks identified by ® or ™ are registered trademarks or trademarks, respectively, of CommScope. All specifications are subject to change.
See www.commscope.com/andrew for the most current information.

page 1 of 2
5/26/2011

Item # W p92

Product Specifications



SSH-12

Vibration Survival

≥4 hours at resonant frequency

Packed Dimensions

Height	15.2 cm 6.0 in
Length	9.0 cm 3.5 in
Shipping Weight	0.36 kg 0.79 lb
Width	10.4 cm 4.1 in

Regulatory Compliance/Certifications

Agency	Classification
ISO 9001:2008	Designed, manufactured and/or distributed under this quality management system

www.commscope.com/andrew

©2011 CommScope, Inc. All rights reserved.
All trademarks identified by ® or ™ are registered trademarks or trademarks, respectively, of CommScope. All specifications are subject to change.
See www.commscope.com/andrew for the most current information.

page 2 of 2
5/26/2011

DPS 1139
Item # 12

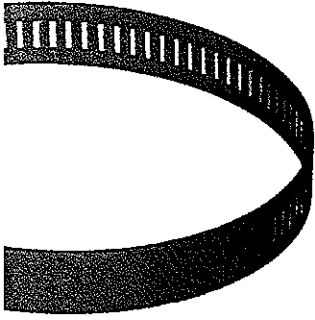

CSB	corrugated, smoothwall, and braided coaxial cable		
252110	Lace-up Hoisting Grip for 1-1/4"	0.6	(0.3)
CSB	corrugated, smoothwall, and braided coaxial cable		
252111	Lace-up Hoisting Grip for 1-5/8"	1.3	(0.6)
CS	corrugated and smoothwall coaxial cable		
252112	Lace-up Hoisting Grip for 2-1/4"	1.3	(0.6)
C	corrugated coaxial cable		

Wt. lb	(Wt. kg)
0.8	(0.4)
1.0	(0.5)
1.2	(0.5)
1.3	(0.6)
1.3	(0.6)
1.3	(0.6)

Clip-on Ground Kits

Application: Grounding
Size: 1/2" to 2-1/4" coaxial cable
Design: One-piece style
Feature: Easy-to-install clip design
Mounts to: Coaxial outer conductor
Material: Copper strap
Includes: Ground kit, lug, and weatherproofing kit

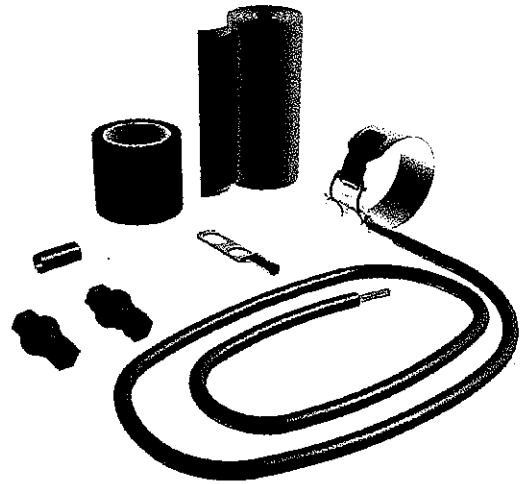

Part Number	Description	Wt. lb	(Wt. kg)
C 294500	Clip-on Ground Kit for 1/2" corrugated coaxial cable, includes 5' (1.5 m) lead with unattached 3/8" (9.5 mm) two-hole lug	1.4	(0.6)
C 294502	Clip-on Ground Kit for 5/8" corrugated coaxial cable, includes 5' (1.5 m) lead with unattached 3/8" (9.5 mm) two-hole lug	1.4	(0.6)
C 294504	Clip-on Ground Kit Tin-plated for 7/8" corrugated copper or corrugated aluminum cable, includes 5' (1.5 m) lead with unattached 3/8" (9.5 mm) two-hole lug	1.4	(0.6)
C 294506	Clip-on Ground Kit for 1-1/4" corrugated coaxial cable, includes 5' (1.5 m) lead with unattached 3/8" (9.5 mm) two-hole lug	1.4	(0.6)
C 294508	Clip-on Ground Kit Tin-plated for 1-5/8" corrugated copper or corrugated aluminum cable, includes 5' (1.5 m) lead with unattached 3/8" (9.5 mm) two-hole lug	1.5	(0.7)
C 294510	Clip-on Ground Kit for 2-1/4" corrugated coaxial cable, includes 5' (1.5 m) lead with unattached 3/8" (9.5 mm) two-hole lug	1.5	(0.7)

its

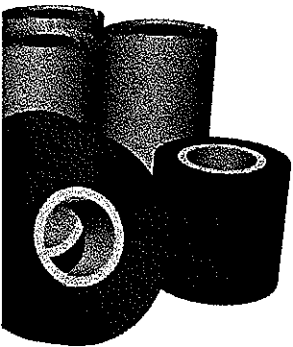

Wt. lb	(Wt. kg)
3.4	(1.5)

FIT CODE LEGEND

- C** = Corrugated cable
- S** = Smoothwall cable
- B** = Braided cable

I-Line™ Accessories

4" Boot Assembly Kits

Application: Entry port solutions

Size: Versions for 1/2" to 2-1/4" coaxial cable

Design: Compression boot kit for aluminum entry panels

Feature: One-piece design simplifies installation

Mounts to: 4" (101.6 mm) Entry Panels

Material: EPDM rubber

Includes: Boot, cushion, two hose clamps

Order Separately: 4" (101.6 mm) Entry Panel

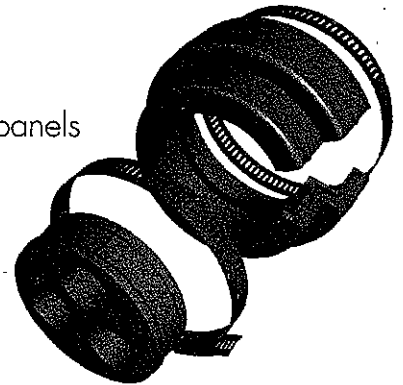

Part Number	Description	Wt. lbs	(Wt. kg)
252146	Boot Assembly Kit, 4" (101.6 mm) with 1 hole for 1/2" corrugated coax	1.6	(0.7)
* 252147	Boot Assembly Kit, 4" (101.6 mm) with 3 holes for 1/2" corrugated coax	1.6	(0.7)
252148	Boot Assembly Kit, 4" (101.6 mm) with 1 hole for 5/8" corrugated and LMR-900 coax	1.6	(0.7)
252149	Boot Assembly Kit, 4" (101.6 mm) with 3 holes for 5/8" corrugated and LMR-900 coax	1.6	(0.7)
252150	Boot Assembly Kit, 4" (101.6 mm) with 1 hole for 7/8" corrugated and LMR-900 coax	1.6	(0.7)
252151	Boot Assembly Kit, 4" (101.6 mm) with 3 holes for 7/8" corrugated coax	1.6	(0.7)
252152	Boot Assembly Kit, 4" (101.6 mm) with 1 hole for 1-1/4" corrugated coax	1.6	(0.7)
252153	Boot Assembly Kit, 4" (101.6 mm) with 1 hole for 1-5/8" corrugated and smooth wall coax	1.6	(0.7)
252154	Boot Assembly Kit, 4" (101.6 mm) with 1 hole for 2-1/4" corrugated coax	1.6	(0.7)

5" Boot Assembly Kits

Application: Entry port solutions

Size: Versions for coaxial 1/2" to 2-1/4" and elliptical waveguide

Design: Compression boot kit for aluminum entry panels

I Item # 20
DPS 1139

ENVELOPE / ASSEMBLY DRAWING

000000

REV	DESCRIPTION	DWN	DATE	APPROVED
B	ADD DIELECTRIC AND CONTACT DIMENSIONS	KMM	6/28/94	R. RICE
C	CHG TO 1 PIECE DIE ITEM #3 / ADD BARB TO CONTACT ITEM #2	CZS	3/10/98	R. RICE
D	CONTACT NOW PHOS BRONZE / UPDATE SPECS	CZS	9/9/99	R. RICE
E	CHANGE CONTACT MATERIAL	CZS	1/26/00	J. D. McR.

ALL DIMENSIONS ARE REFERENCE ONLY

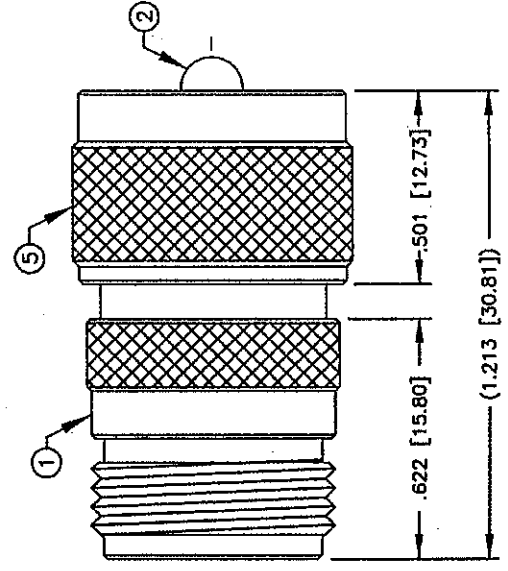

SPECIFICATIONS:

IMPEDANCE: 50 OHMS
 WORKING VOLTAGE: 500 VRMS @ SEA LEVEL
 FREQUENCY RANGE: 0-300 MHz
 INTERFACE PER MIL-STD-348, SECTION 304.2

ITEM	DESCRIPTION	QTY	MATERIAL	FINISH
5	SHELL	1	BRASS	SILVER
4	RETAINING RING	1	BRASS	NONE
3	DIELECTRIC	1	TEFLON	NONE
2	CONTACT	1	BRASS	GOLD
1	BODY	1	BRASS	SILVER

DIMENSIONS ARE IN INCHES AND [MILLIMETERS]
 UNLESS OTHERWISE NOTED TOLERANCES ARE: DECIMALS DIAMETER

DRAWN C. ZUNIGA	1/26/00
CHECKED CJM	1-26-00
ORJ DRAWN C. JONES	11/4/91
APPROVALS	DATE

RF connectors
 DIVISION OF RF INDUSTRIES, LTD.
 7610 MIRAMAR RD
 SAN DIEGO, CA 92126
 (858) 549-6340
 (858) 549-6345 FAX

RFN-1036-1 / UG-83B/U	
N FEMALE TO UHF MALE	
SIZE	CABLE GROUP
A	N/A
DWG NO.	7280
REV	E
SCALE: 2:1	CAD FILE 13ARC B
SHEET 1	OF 1

Product Specifications



MT-586G-250

Ground Wire, #6 AWG, stranded insulated, green jacket, 250 ft roll

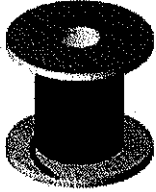

CHARACTERISTICS

Dimensions

Height	152.4 mm 6.0 in
Length	609.6 mm 24.0 in
Weight	15.0 kg 33.0 lb
Width	609.6 mm 24.0 in

General Specifications

Product Type	Ground wire
Material Type	Copper
Includes	Copper wire
Package Quantity	1

Regulatory Compliance/Certifications

Agency	Classification
ISO 9001:2008	Designed, manufactured and/or distributed under this quality management system

www.commscope.com/andrew

©2011 CommScope, Inc. All rights reserved.
 All trademarks identified by ® or ™ are registered trademarks or trademarks, respectively, of CommScope. All specifications are subject to change.
 See www.commscope.com/andrew for the most current information.

page 1 of 1
 5/26/2011

N/A

Rev. 09/08

State of West Virginia VENDOR PREFERENCE CERTIFICATE

Certification and application* is hereby made for Preference in accordance with *West Virginia Code*, §5A-3-37. (Does not apply to construction contracts). *West Virginia Code*, §5A-3-37, provides an opportunity for qualifying vendors to request (at the time of bid) preference for their residency status. Such preference is an evaluation method only and will be applied only to the cost bid in accordance with the *West Virginia Code*. This certificate for application is to be used to request such preference. The Purchasing Division will make the determination of the Resident Vendor Preference, if applicable.

1. **Application is made for 2.5% resident vendor preference for the reason checked:**
 Bidder is an individual resident vendor and has resided continuously in West Virginia for four (4) years immediately preceding the date of this certification; or,
 Bidder is a partnership, association or corporation resident vendor and has maintained its headquarters or principal place of business continuously in West Virginia for four (4) years immediately preceding the date of this certification; or 80% of the ownership interest of Bidder is held by another individual, partnership, association or corporation resident vendor who has maintained its headquarters or principal place of business continuously in West Virginia for four (4) years immediately preceding the date of this certification; or,
 Bidder is a nonresident vendor which has an affiliate or subsidiary which employs a minimum of one hundred state residents and which has maintained its headquarters or principal place of business within West Virginia continuously for the four (4) years immediately preceding the date of this certification; or,
2. **Application is made for 2.5% resident vendor preference for the reason checked:**
 Bidder is a resident vendor who certifies that, during the life of the contract, on average at least 75% of the employees working on the project being bid are residents of West Virginia who have resided in the state continuously for the two years immediately preceding submission of this bid; or,
3. **Application is made for 2.5% resident vendor preference for the reason checked:**
 Bidder is a nonresident vendor employing a minimum of one hundred state residents or is a nonresident vendor with an affiliate or subsidiary which maintains its headquarters or principal place of business within West Virginia employing a minimum of one hundred state residents who certifies that, during the life of the contract, on average at least 75% of the employees or Bidder's affiliate's or subsidiary's employees are residents of West Virginia who have resided in the state continuously for the two years immediately preceding submission of this bid; or,
4. **Application is made for 5% resident vendor preference for the reason checked:**
 Bidder meets either the requirement of both subdivisions (1) and (2) or subdivision (1) and (3) as stated above; or,
5. **Application is made for 3.5% resident vendor preference who is a veteran for the reason checked:**
 Bidder is an individual resident vendor who is a veteran of the United States armed forces, the reserves or the National Guard and has resided in West Virginia continuously for the four years immediately preceding the date on which the bid is submitted; or,
6. **Application is made for 3.5% resident vendor preference who is a veteran for the reason checked:**
 Bidder is a resident vendor who is a veteran of the United States armed forces, the reserves or the National Guard, if, for purposes of producing or distributing the commodities or completing the project which is the subject of the vendor's bid and continuously over the entire term of the project, on average at least seventy-five percent of the vendor's employees are residents of West Virginia who have resided in the state continuously for the two immediately preceding years.

Bidder understands if the Secretary of Revenue determines that a Bidder receiving preference has failed to continue to meet the requirements for such preference, the Secretary may order the Director of Purchasing to: (a) reject the bid; or (b) assess a penalty against such Bidder in an amount not to exceed 5% of the bid amount and that such penalty will be paid to the contracting agency or deducted from any unpaid balance on the contract or purchase order.

By submission of this certificate, Bidder agrees to disclose any reasonably requested information to the Purchasing Division and authorizes the Department of Revenue to disclose to the Director of Purchasing appropriate information verifying that Bidder has paid the required business taxes, provided that such information does not contain the amounts of taxes paid nor any other information deemed by the Tax Commissioner to be confidential.

Under penalty of law for false swearing (*West Virginia Code*, §61-5-3), Bidder hereby certifies that this certificate is true and accurate in all respects; and that if a contract is issued to Bidder and if anything contained within this certificate changes during the term of the contract, Bidder will notify the Purchasing Division in writing immediately.

Bidder: _____ Signed: _____

Date: _____ Title: _____

*Check any combination of preference consideration(s) indicated above, which you are entitled to receive.

RFQ No. DPS 1139

STATE OF WEST VIRGINIA
Purchasing Division

PURCHASING AFFIDAVIT

West Virginia Code §5A-3-10a states: No contract or renewal of any contract may be awarded by the state or any of its political subdivisions to any vendor or prospective vendor when the vendor or prospective vendor or a related party to the vendor or prospective vendor is a debtor and the debt owed is an amount greater than one thousand dollars in the aggregate.

DEFINITIONS:

"Debt" means any assessment, premium, penalty, fine, tax or other amount of money owed to the state or any of its political subdivisions because of a judgment, fine, permit violation, license assessment, defaulted workers' compensation premium, penalty or other assessment presently delinquent or due and required to be paid to the state or any of its political subdivisions, including any interest or additional penalties accrued thereon.

"Debtor" means any individual, corporation, partnership, association, limited liability company or any other form or business association owing a debt to the state or any of its political subdivisions. "Political subdivision" means any county commission; municipality; county board of education; any instrumentality established by a county or municipality; any separate corporation or instrumentality established by one or more counties or municipalities, as permitted by law; or any public body charged by law with the performance of a government function or whose jurisdiction is coextensive with one or more counties or municipalities. "Related party" means a party, whether an individual, corporation, partnership, association, limited liability company or any other form or business association or other entity whatsoever, related to any vendor by blood, marriage, ownership or contract through which the party has a relationship of ownership or other interest with the vendor so that the party will actually or by effect receive or control a portion of the benefit, profit or other consideration from performance of a vendor contract with the party receiving an amount that meets or exceeds five percent of the total contract amount.

EXCEPTION: The prohibition of this section does not apply where a vendor has contested any tax administered pursuant to chapter eleven of this code, workers' compensation premium, permit fee or environmental fee or assessment and the matter has not become final or where the vendor has entered into a payment plan or agreement and the vendor is not in default of any of the provisions of such plan or agreement.

Under penalty of law for false swearing (*West Virginia Code* §61-5-3), it is hereby certified that the vendor affirms and acknowledges the information in this affidavit and is in compliance with the requirements as stated.

WITNESS THE FOLLOWING SIGNATURE

Vendor's Name: Talley

Authorized Signature: [Signature] Date: 5/26/11

State of CA

County of Los Angeles, to-wit:

Taken, subscribed, and sworn to before me this 26 day of MAY, 2011.

My Commission expires SEPTEMBER 6, 2012.

AFFIX SEAL HERE

NOTARY PUBLIC Victoria H. Osborn

