



State of West Virginia
 Department of Administration
 Purchasing Division
 2019 Washington Street East
 Post Office Box 50130
 Charleston, WV 25305-0130

Request for Quotation

RFQ NUMBER
DNRB11155

PAGE
1

ADDRESS CORRESPONDENCE TO ATTENTION OF
FRANK WHITTAKER
304-558-2316

VENDOR

RFQ COPY
 TYPE NAME / ADDRESS

ALLIED REFRIGERATION
PO BOX 184
ANMOORE, WV 26323

BUYER

DIVISION OF NATURAL RESOURCES
TYGART LAKE STATE PARK
ATTN: PARK SUPERINTENDENT
ROUTE 1, BOX 260
GRAFTON, WV
26354 265-3383

DATE PRINTED	TERMS OF SALE	SHIP VIA	FOB	FREIGHT TERMS
03/23/2011				

BID OPENING DATE: **04/26/2011** BID OPENING TIME: **01:30PM**

LINE	QUANTITY	UOP	CAT NO	ITEM NUMBER	UNIT PRICE	AMOUNT
0001	1	LS		740-70		
<p>COMMERCIAL RESTAURANT EQUIPMENT</p> <p>THE WEST VIRGINIA PURCHASING DIVISION, FOR THE AGENCY, THE WEST VIRGINIA DIVISION OF NATURAL RESOURCES IS SOLICITING BIDS FOR COMMERCIAL RESTAURANT EQUIPMENT FOR TYGART LAKE STATE PARK PER THE ATTACHED SPECIFICATIONS.</p> <p>ALL TECHNICAL QUESTIONS MUST BE SUBMITTED IN WRITING TO FRANK WHITTAKER IN THE WV PURCHASING DIVISION VIA EMAIL AT FRANK.M.WHITTAKER@WV.GOV OR VIA FAX AT 304-558-4115. DEADLINE FOR ALL TECHNICAL QUESTIONS IS 04/07/2011. ALL TECHNICAL QUESTIONS WILL BE ADDRESSED BY ADDENDUM AFTER THE DEADLINE.</p> <p>ALL BIDDERS ARE ENCOURAGED TO VISIT THE SITE.</p> <p>EXHIBIT 5</p> <p>WEST VIRGINIA CODE 21-1D-5 PROVIDES THAT: ANY SOLICITATION FOR A PUBLIC IMPROVEMENT CONSTRUCTION CONTRACT REQUIRES EACH VENDOR THAT SUBMITS A BID FOR THE WORK TO SUBMIT AT THE SAME TIME AN AFFIDAVIT OF COMPLIANCE WITH THE BID. THE ENCLOSED DRUG-FREE WORKPLACE AFFIDAVIT MUST BE SIGNED AND SUBMITTED WITH THE BID AS EVIDENCE OF THE VENDOR'S COMPLIANCE WITH THE PROVISIONS OF ARTICLE 1D, CHAPTER 21 OF THE WEST VIRGINIA CODE. FAILURE TO SUBMIT THE SIGNED DRUG-FREE WORKPLACE AFFIDAVIT WITH THE BID SHALL RESULT IN DISQUALIFICATION OF SUCH BID.</p>						

RECEIVED
 APR 25 A 9:44
 PURCHASING DIVISION
 STATE OF WV

SEE REVERSE SIDE FOR TERMS AND CONDITIONS

SIGNATURE	TELEPHONE	DATE
TITLE	FEIN	ADDRESS CHANGES TO BE NOTED ABOVE

WHEN RESPONDING TO RFQ, INSERT NAME AND ADDRESS IN SPACE ABOVE LABELED 'VENDOR'



State of West Virginia
 Department of Administration
 Purchasing Division
 2019 Washington Street East
 Post Office Box 50130
 Charleston, WV 25305-0130

Request for Quotation

RFQ NUMBER
DNRB11155

PAGE
2

ADDRESS CORRESPONDENCE TO ATTENTION OF:
FRANK WHITTAKER
304-558-2316

RFQ COPY

TYPE NAME/ADDRESS HERE

SHIP TO

DIVISION OF NATURAL RESOURCES
 TYGART LAKE STATE PARK
 ATTN: PARK SUPERINTENDENT
 ROUTE 1, BOX 260
 GRAFTON, WV
 26354 265-3383

DATE PRINTED	TERMS OF SALE	SHIP VIA	FOB	FREIGHT TERMS
03/23/2011				

BID OPENING DATE: **04/26/2011** BID OPENING TIME **01:30PM**

LINE	QUANTITY	UOP	CAT NO	ITEM NUMBER	UNIT PRICE	AMOUNT
<p>NOTICE TO PROCEED: THIS CONTRACT IS TO BE PERFORMED WITHIN 30 CALENDAR DAYS AFTER THE NOTICE TO PROCEED IS RECEIVED. UNLESS OTHERWISE SPECIFIED, THE FULLY EXECUTED PURCHASE ORDER WILL BE CONSIDERED NOTICE TO PROCEED.</p> <p>CANCELLATION: THE DIRECTOR OF PURCHASING RESERVES THE RIGHT TO CANCEL THIS CONTRACT IMMEDIATELY UPON WRITTEN NOTICE TO THE VENDOR IF THE MATERIALS OR WORKMANSHIP SUPPLIED ARE OF AN INFERIOR QUALITY OR DO NOT CONFORM WITH THE SPECIFICATIONS OF THE BID AND CONTRACT HERE IN.</p> <p>WAGE RATES: THE CONTRACTOR OR SUBCONTRACTOR SHALL PAY THE HIGHER OF THE U.S. DEPARTMENT OF LABOR MINIMUM WAGE RATES AS ESTABLISHED FOR TAYLOR COUNTY, PURSUANT TO WEST VIRGINIA CODE 21-5A, ET, SEQ. (PREVAILING WAGE RATES APPLY TO THIS PROJECT)</p> <p>ARBITRATION: ANY REFERENCES MADE TO ARBITRATION OR INTEREST FOR PAYMENTS DUE (EXCEPT FOR ANY INTEREST REQUIRED BY STATE LAW) CONTAINED IN THIS CONTRACT OR IN ANY AMERICAN INSTITUTE OF ARCHITECTS DOCUMENTS PERTAINING TO THIS CONTRACT ARE HEREBY DELETED.</p> <p>WORKERS' COMPENSATION: VENDOR IS REQUIRED TO PROVIDE A CERTIFICATE FROM WORKERS' COMPENSATION IF SUCCESSFUL.</p> <p>ALL OF THE ITEMS CHECKED BELOW WILL BE A REQUIREMENT OF THIS CONTRACT:</p> <p>(XX) INSURANCE: SUCCESSFUL VENDOR SHALL FURNISH PROOF OF COMMERCIAL GENERAL LIABILITY INSURANCE PRIOR TO ISSUANCE OF CONTRACT. UNLESS OTHERWISE SPECIFIED IN THE BID DOCUMENTS, THE MINIMUM AMOUNT OF INSURANCE</p>						

SEE REVERSE SIDE FOR TERMS AND CONDITIONS

SIGNATURE	TELEPHONE	DATE
TITLE	FEIN	ADDRESS CHANGES TO BE NOTED ABOVE

WHEN RESPONDING TO RFQ, INSERT NAME AND ADDRESS IN SPACE ABOVE LABELED 'VENDOR'



State of West Virginia
 Department of Administration
 Purchasing Division
 2019 Washington Street East
 Post Office Box 50130
 Charleston, WV 25305-0130

**Request for
 Quotation**

RFQ NUMBER
DNRB11155

PAGE
3

ADDRESS CORRESPONDENCE TO ATTENTION OF
**FRANK WHITTAKER
 304-558-2316**

SUCCESSFUL

RFQ COPY
 TYPE NAME/ADDRESS HERE

SHIP TO

DIVISION OF NATURAL RESOURCES
 TYGART LAKE STATE PARK
 ATTN: PARK SUPERINTENDENT
 ROUTE 1, BOX 260
 GRAFTON, WV
 26354 265-3383

DATE PRINTED	TERMS OF SALE	SHIP VIA	FOB	FREIGHT TERMS
03/23/2011				

BID OPENING DATE: **04/26/2011** BID OPENING TIME **01:30PM**

LINE	QUANTITY	UOP	CAT NO	ITEM NUMBER	UNIT PRICE	AMOUNT
<p>COVERAGE REQUIRED IS \$250,000.</p> <p>() BUILDERS RISK INSURANCE: SUCCESSFUL VENDOR SHALL FURNISH PROOF OF BUILDERS RISK - ALL RISK INSURANCE IN AN AMOUNT EQUAL TO 100% OF THE AMOUNT OF THE CONTRACT.</p> <p>(XX) BONDS: FIVE PERCENT (5%) OF THE TOTAL AMOUNT OF THE BID PAYABLE TO THE STATE OF WEST VIRGINIA, SHALL BE SUBMITTED WITH EACH BID AS A BID BOND. THE SUCCESSFUL BIDDER SHALL ALSO FURNISH A PERFORMANCE BOND AND LABOR/MATERIAL BOND FOR 100% OF THE AMOUNT OF THE CONTRACT. BONDS MAY BE PROVIDED IN THE FORM OF A CERTIFIED CHECK IRREVOCABLE LETTER OF CREDIT, OR BOND FURNISHED BY A SOLVENT SURETY COMPANY AUTHORIZED TO DO BUSINESS IN THE STATE OF WEST VIRGINIA. A LETTER OF CREDIT SUBMITTED IN LIEU OF A BOND WILL ONLY BE ALLOWED FOR PROJECTS UNDER \$100,000. PERSONAL OR BUSINESS CHECKS ARE NOT ACCEPTABLE IN LIEU OF THE 5% BID BOND, PERFORMANCE BOND, OR LABOR AND MATERIAL BOND.</p> <p>() MAINTENANCE BOND: A TWO (2) YEAR MAINTENANCE BOND COVERING THE ROOFING SYSTEM WILL BE A REQUIREMENT OF THE SUCCESSFUL VENDOR.</p> <p>REV. 11/00</p> <p>EXHIBIT 7</p> <p>DOMESTIC ALUMINUM, GLASS & STEEL IN PUBLIC WORKS PROJECTS</p> <p>IN ACCORDANCE WITH WEST VIRGINIA CODE 5-19-1 ET., SEQ., EVERY CONTRACT FOR CONSTRUCTION, RECONSTRUCTION, ALTERATION, REPAIR, IMPROVEMENT OR MAINTENANCE OF PUBLIC WORKS, WHERE THE COST IS MORE THAN \$50,000 AND,</p>						

SEE REVERSE SIDE FOR TERMS AND CONDITIONS

SIGNATURE	TELEPHONE	DATE
TITLE	FEIN	ADDRESS CHANGES TO BE NOTED ABOVE

WHEN RESPONDING TO RFQ, INSERT NAME AND ADDRESS IN SPACE ABOVE LABELED 'VENDOR'



State of West Virginia
 Department of Administration
 Purchasing Division
 2019 Washington Street East
 Post Office Box 50130
 Charleston, WV 25305-0130

Request for Quotation

RFQ NUMBER
DNRB11155

PAGE
4

ADDRESS CORRESPONDENCE TO ATTENTION TO
FRANK WHITTAKER
304-558-2316

VENDOR

RFQ COPY
 TYPE NAME/ADDRESS HERE

VENDOR

DIVISION OF NATURAL RESOURCES
 TYGART LAKE STATE PARK
 ATTN: PARK SUPERINTENDENT
 ROUTE 1, BOX 260
 GRAFTON, WV
 26354 265-3383

DATE PRINTED	TERMS OF SALE	SHIP VIA	F.O.B.	FREIGHT TERMS
03/23/2011				

BID OPENING DATE: **04/26/2011** BID OPENING TIME: **01:30PM**

LINE	QUANTITY	UOP	CAT NO	ITEM NUMBER	UNIT PRICE	AMOUNT
<p>IN THE CASE OF STEEL ONLY, WHERE THE COST OF STEEL IS MORE THAN \$50,000 OR WHERE MORE THAN 10,000 POUNDS OF STEEL ARE REQUIRED, THE STATE WILL ACCEPT ONLY ALUMINUM GLASS, OR STEEL PRODUCTS PRODUCED IN THE UNITED STATES. IN ADDITION, ITEMS OF MACHINERY OR EQUIPMENT PURCHASED FOR USE AT THE SITE OF PUBLIC WORKS SHALL BE MADE OF DOMESTIC ALUMINUM, GLASS OR STEEL, UNLESS THE COST OF THE PRODUCT IS LESS THAN \$50,000 OR LESS THAN 10,000 POUNDS OF STEEL ARE USED IN PUBLIC WORKS PROJECTS.</p> <p>FOREIGN MADE ALUMINUM, GLASS OR STEEL PRODUCTS MAY BE ACCEPTED ONLY IF THE COST OF DOMESTIC PRODUCTS IS FOUND TO BE UNREASONABLE. SUCH COST IS UNREASONABLE IF IT IS 20% OR MORE HIGHER THAN THE BID PRICE FOR FOREIGN MADE PRODUCTS. IF THE DOMESTIC ALUMINUM, GLASS OR STEEL PRODUCTS TO BE SUPPLIED OR PRODUCED IN A "SUBSTANTIAL LABOR SURPLUS AREA", AS DEFINED BY THE UNITED STATES DEPARTMENT OF LABOR, FOREIGN PRODUCTS MAY BE SUPPLIED ONLY IF DOMESTIC PRODUCTS ARE 30% OR MORE HIGHER IN PRICE THAN THE FOREIGN MADE PRODUCTS.</p> <p>IF, PRIOR TO THE AWARD OF A CONTRACT UNDER THE ABOVE PROVISIONS, THE SPENDING OFFICER OF THE SPENDING UNIT DETERMINES THAT THERE EXISTS A BID FOR LIKE FOREIGN ALUMINUM, GLASS OR STEEL THAT IS REASONABLE AND LOWER THAN THE LOWEST BID DOMESTIC PRODUCTS, THE SPENDING OFFICE MAY REQUEST, IN WRITING, A REEVALUATION AND REDUCTION IN THE LOWEST BID FOR SUCH DOMESTIC PRODUCTS. ALL VENDORS MUST INDICATE IN THEIR BID IF THEY ARE SUPPLYING FOREIGN ALUMINUM, GLASS OR STEEL.</p> <p>REV. 3/88</p> <p>EXHIBIT 9</p>						

SEE REVERSE SIDE FOR TERMS AND CONDITIONS

SIGNATURE	TELEPHONE	DATE
TITLE	FEIN	ADDRESS CHANGES TO BE NOTED ABOVE

WHEN RESPONDING TO RFQ, INSERT NAME AND ADDRESS IN SPACE ABOVE LABELED 'VENDOR'



State of West Virginia
 Department of Administration
 Purchasing Division
 2019 Washington Street East
 Post Office Box 50130
 Charleston, WV 25305-0190

Request for Quotation

RFQ NUMBER
DNRB11155

PAGE
5

ADDRESS CORRESPONDENCE TO ATTENTION OF
FRANK WHITTAKER
304-558-2316

VENDOR

RFQ COPY
 TYPE NAME/ADDRESS HERE

VENDOR

DIVISION OF NATURAL RESOURCES
 TYGART LAKE STATE PARK
 ATTN: PARK SUPERINTENDENT
 ROUTE 1, BOX 260
 GRAFTON, WV
 26354 265-3383

DATE PRINTED	TERMS OF SALE	SHIP VIA	FOB	FREIGHT TERMS		
03/23/2011						
BID OPENING DATE: 04/26/2011		BID OPENING TIME 01:30PM				
LINE	QUANTITY	UOP	CAT NO	ITEM NUMBER	UNIT PRICE	AMOUNT
<p>NOTICE FOR ISSUANCE & ACKNOWLEDGEMENT OF CONSTRUCTION PROJECT ADDENDA</p> <p>THE ARCHITECT/ENGINEER AND/OR AGENCY SHALL BE REQUIRED TO ABIDE BY THE FOLLOWING SCHEDULE IN ISSUING CONSTRUCTION PROJECT ADDENDA FOR STATE AGENCIES:</p> <p>(1) THE ARCHITECT/ENGINEER SHALL PREPARE THE ADDENDUM AND A LIST OF ALL PARTIES THAT HAVE PROCURED DRAWINGS AND SPECIFICATIONS FOR THE PROJECT. THE ADDENDUM AND LIST SHALL BE FORWARDED TO THE BUYER IN THE STATE PURCHASING DIVISION. THE ARCHITECT/ENGINEER SHALL ALSO SEND A COPY OF THE ADDENDUM TO THE STATE AGENCY FOR WHICH THE CONTRACT IS ISSUED.</p> <p>(2) THE BUYER SHALL SEND THE ADDENDUM TO ALL INTERESTED PARTIES AND, IF NECESSARY, EXTEND THE BID OPENING DATE. ANY ADDENDUM SHOULD BE RECEIVED BY THE BUYER WITHIN FOURTEEN (14) DAYS PRIOR TO THE BID OPENING DATE.</p> <p>(3) ALL ADDENDA SHOULD BE FORMALLY ACKNOWLEDGED BY ALL BIDDERS AND SUBMITTED TO THE STATE PURCHASING DIVISION. THE SAME RULES AND REGULATIONS THAT APPLY TO THE ORIGINAL BIDDING DOCUMENT SHALL ALSO APPLY TO AN ADDENDUM DOCUMENT. THE ONLY EXCEPTION MAY BE FOR AN ADDENDUM THAT IS ISSUED FOR THE SOLE PURPOSE OF CHANGING A BID OPENING TIME AND/OR DATE.</p> <p>REV. 11/96</p> <p>EXHIBIT 10</p> <p>ADDENDUM ACKNOWLEDGEMENT</p>						
SEE REVERSE SIDE FOR TERMS AND CONDITIONS						
SIGNATURE			TELEPHONE		DATE	
TITLE		FEIN		ADDRESS CHANGES TO BE NOTED ABOVE		

WHEN RESPONDING TO RFQ, INSERT NAME AND ADDRESS IN SPACE ABOVE LABELED 'VENDOR'



State of West Virginia
 Department of Administration
 Purchasing Division
 2019 Washington Street East
 Post Office Box 50130
 Charleston, WV 25305-0130

Request for Quotation

RFQ NUMBER
DNRB11155

PAGE
6

ADDRESS CORRESPONDENCE TO ATTENTION OF
FRANK WHITTAKER
304-558-2316

VENDOR

RFQ COPY
 TYPE NAME/ADDRESS HERE

BUYER

DIVISION OF NATURAL RESOURCES
 TYGART LAKE STATE PARK
 ATTN: PARK SUPERINTENDENT
 ROUTE 1, BOX 260
 GRAFTON, WV
 26354 265-3383

DATE PRINTED 03/23/2011	TERMS OF SALE	SHIP VIA	FOB	FREIGHT TERMS
-----------------------------------	---------------	----------	-----	---------------

BID OPENING DATE: **04/26/2011** BID OPENING TIME **01:30PM**

LINE	QUANTITY	UICP	CAT NO	ITEM NUMBER	UNIT PRICE	AMOUNT
<p>I HEREBY ACKNOWLEDGE RECEIPT OF THE FOLLOWING CHECKED ADDENDUM(S) AND HAVE MADE THE NECESSARY REVISIONS TO MY PROPOSAL, PLANS AND/OR SPECIFICATION, ETC.</p> <p>ADDENDUM NOS.:</p> <p>NO. 1</p> <p>NO. 2</p> <p>NO. 3</p> <p>NO. 4</p> <p>NO. 5</p> <p>I UNDERSTAND THAT FAILURE TO CONFIRM THE RECEIPT OF TH ADDENDUM(S) MAY BE CAUSE FOR REJECTION OF THE BIDS..</p> <p>VENDOR MUST CLEARLY UNDERSTAND THAT ANY VERBAL REPRESENTATION MADE OR ASSUMED TO BE MADE DURING ANY ORAL DISCUSSION HELD BETWEEN VENDOR'S REPRESENTATIVES AND ANY STATE PERSONNEL IS NOT BINDING. ONLY THE INFORMATION ISSUED IN WRITING AND ADDED TO THE SPECIFICATIONS BY AN OFFICIAL ADDENDUM IS BINDING.</p> <p><i>Alfred Refrigeration, Inc</i>SIGNATURE</p> <p><i>Alfred Refrigeration, Inc</i>COMPANY</p> <p><i>4/20/11</i>DATE</p> <p>REV. 11/96</p>						

SEE REVERSE SIDE FOR TERMS AND CONDITIONS

SIGNATURE: *Alfred Refrigeration, Inc* TELEPHONE: **304-669-0520** DATE: **4-20-11**

TITLE: **owner** FEIN: **201869281** ADDRESS CHANGES TO BE NOTED ABOVE

WHEN RESPONDING TO RFQ, INSERT NAME AND ADDRESS IN SPACE ABOVE LABELED 'VENDOR'



State of West Virginia
 Department of Administration
 Purchasing Division
 2019 Washington Street East
 Post Office Box 50130
 Charleston, WV 25305-0130

Request for Quotation

RFQ NUMBER
DNRB11155

PAGE
7

ADDRESS CORRESPONDENCE TO ATTENTION OF
FRANK WHITTAKER
304-558-2316

VENDOR

RFQ COPY
 TYPE NAME/ADDRESS HERE

SHIP TO

DIVISION OF NATURAL RESOURCES
 TYGART LAKE STATE PARK
 ATTN: PARK SUPERINTENDENT
 ROUTE 1, BOX 260
 GRAFTON, WV
 26354 265-3383

DATE PRINTED	TERMS OF SALE	SHIP VIA	FOB	FREIGHT TERMS
03/23/2011				

BID OPENING DATE: **04/26/2011** BID OPENING TIME: **01:30PM**

LINE	QUANTITY	UOP	UNIT NO	ITEM NUMBER	UNIT PRICE	AMOUNT
CONTRACTORS LICENSE						
WEST VIRGINIA STATE CODE 21-11-2 REQUIRES THAT ALL PERSONS DESIRING TO PERFORM CONTRACTING WORK IN THIS STATE MUST BE LICENSED. THE WEST VIRGINIA CONTRACTORS LICENSING BOARD IS EMPOWERED TO ISSUE THE CONTRACTORS LICENSE. APPLICATIONS FOR A CONTRACTORS LICENSE MAY BE MADE BY CONTACTING THE WEST VIRGINIA DIVISION OF LABOR CAPITOL COMPLEX, BUILDING 3, ROOM 319, CHARLESTON, WV 25305. TELEPHONE: (304) 558-7890.						
WEST VIRGINIA STATE CODE 21-11-11 REQUIRES ANY PROSPECTIVE BIDDER TO INCLUDE THE CONTRACTORS LICENSE NUMBER ON THEIR BID.						
BIDDER TO COMPLETE:						
CONTRACTORS NAME: <i>Damon C. Bolden</i>						
CONTRACTORS LICENSE NO.: <i>WV 039476</i>						
THE SUCCESSFUL BIDDER WILL BE REQUIRED TO FURNISH A COPY OF THEIR CONTRACTORS LICENSE PRIOR TO ISSUANCE OF A PURCHASE ORDER/CONTRACT						
APPLICABLE LAW						
THE WEST VIRGINIA STATE CODE, PURCHASING DIVISION RULES AND REGULATIONS, AND THE INFORMATION PROVIDED IN THE "REQUEST FOR QUOTATION" ISSUED BY THE PURCHASING DIVISION IS THE SOLE AUTHORITY GOVERNING THIS PROCUREMENT.						
ANY INFORMATION PROVIDED IN SPECIFICATION MANUALS, OR ANY OTHER SOURCE, VERBAL OR WRITTEN, WHICH CONTRADICTS						

SEE REVERSE SIDE FOR TERMS AND CONDITIONS

SIGNATURE	TELEPHONE	DATE
TITLE	FEIN	ADDRESS CHANGES TO BE NOTED ABOVE

WHEN RESPONDING TO RFQ, INSERT NAME AND ADDRESS IN SPACE ABOVE LABELED 'VENDOR'

CONTRACTOR LICENSE

Authorized by the

West Virginia Contractor Licensing Board

Number: WV039476

Classification:

ELECTRICAL
HEATING, VENTILATING & COOLING

ALLIED REFRIGERATION INC
DBA ALLIED REFRIGERATION INC
PO BOX 184
ANMOORE, WV 26323

Date Issued

AUGUST 31, 2010

Expiration Date

AUGUST 31, 2011

Authorized Company Signature

Chair, West Virginia Contractor
Licensing Board

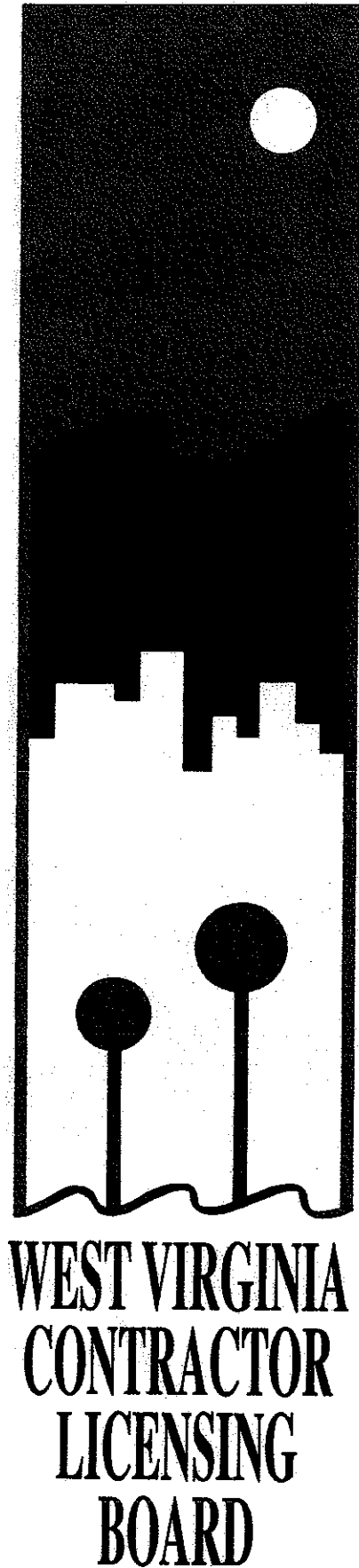

This license, or a copy thereof, must be posted in a conspicuous place at every construction site where work is being performed. This license number must appear in all advertisements, on all bid submissions and on all fully executed and binding contracts. This license cannot be assigned or transferred by licensee. Issued under provisions of West Virginia Code, Chapter 21, Article 11.



State of West Virginia
 Department of Administration
 Purchasing Division
 2019 Washington Street East
 Post Office Box 50130
 Charleston, WV 25305-0130

Request for Quotation

RFQ NUMBER
DNRB11155

PAGE
8

ADDRESS CORRESPONDENCE TO ATTENTION TO
**FRANK WHITTAKER
 304-558-2316**

RFQ COPY
 TYPE NAME/ADDRESS HERE

VENDOR

SHIP TO

DIVISION OF NATURAL RESOURCES
 TYGART LAKE STATE PARK
 ATTN: PARK SUPERINTENDENT
 ROUTE 1, BOX 260
 GRAFTON, WV
 26354 265-3383

DATE PRINTED	TERMS OF SALE	SHIP VIA	FOB	FREIGHT TERMS
03/23/2011				

BID OPENING DATE: **04/26/2011** BID OPENING TIME **01:30PM**

LINE	QUANTITY	UOP	CAT NO	ITEM NUMBER	UNIT PRICE	AMOUNT
<p>OR ALTERS THE INFORMATION PROVIDED FROM THE SOURCES AS DESCRIBED IN THE ABOVE PARAGRAPH IS VOID AND OF NO EFFECT.</p> <p>BANKRUPTCY: IN THE EVENT THE VENDOR/CONTRACTOR FILES FOR BANKRUPTCY PROTECTION, THE STATE MAY DEEM THE CONTRACT NULL AND VOID, AND TERMINATE SUCH CONTRACT WITHOUT FURTHER ORDER.</p> <p>REV. 5/2009</p> <p style="text-align: center;">NOTICE</p> <p>A SIGNED BID MUST BE SUBMITTED TO:</p> <p style="text-align: center;">DEPARTMENT OF ADMINISTRATION PURCHASING DIVISION BUILDING 15 2019 WASHINGTON STREET, EAST CHARLESTON, WV 25305-0130</p> <p>THE BID SHOULD CONTAIN THIS INFORMATION ON THE FACE OF THE ENVELOPE OR THE BID MAY NOT BE CONSIDERED:</p> <p>SEALED BID</p> <p>BUYER: 44</p> <p>REQ. NO.: DNRB11155</p> <p>BID OPENING DATE: 04/26/2011</p> <p>BID OPENING TIME: 1:30 PM</p>						

SEE REVERSE SIDE FOR TERMS AND CONDITIONS

SIGNATURE: *James C. Bolder* TELEPHONE: DATE:

TITLE: *Owner* FEIN: ADDRESS CHANGES TO BE NOTED ABOVE

WHEN RESPONDING TO RFQ, INSERT NAME AND ADDRESS IN SPACE ABOVE LABELED 'VENDOR'



State of West Virginia
 Department of Administration
 Purchasing Division
 2019 Washington Street East
 Post Office Box 50130
 Charleston, WV 25305-0130

Request for Quotation

RFQ NUMBER
DNRB11155

PAGE
9

ADDRESS CORRESPONDENCE TO ATTENTION OF
FRANK WHITTAKER
304-558-2316

RFQ COPY
 TYPE NAME/ADDRESS HERE

DIVISION OF NATURAL RESOURCES
 TYGART LAKE STATE PARK
 ATTN: PARK SUPERINTENDENT
 ROUTE 1, BOX 260
 GRAFTON, WV
 26354 265-3383

DATE PRINTED	TERMS OF SALE	SHIP VIA	FOB	FREIGHT TERMS
03/23/2011				

BID OPENING DATE: **04/26/2011** BID OPENING TIME: **01:30PM**

LINE	QUANTITY	UOP	CAT NO	ITEM NUMBER	UNIT PRICE	AMOUNT
<p>PLEASE PROVIDE A FAX NUMBER IN CASE IT IS NECESSARY TO CONTACT YOU REGARDING YOUR BID: <i>304-622-1460</i></p> <p>PLEASE PRINT OR TYPE NAME OF PERSON TO CONTACT CONCERNING THIS QUOTE: <i>DAMON C BOLDEN - OWNER</i></p> <p>***** THIS IS THE END OF RFQ DNRB11155 ***** TOTAL: _____</p>						

SEE REVERSE SIDE FOR TERMS AND CONDITIONS

SIGNATURE	TELEPHONE	DATE
TITLE	FEIN	ADDRESS CHANGES TO BE NOTED ABOVE

WHEN RESPONDING TO RFQ, INSERT NAME AND ADDRESS IN SPACE ABOVE LABELED 'VENDOR'

Pricing Sheet & Manufacturer's List

Item Number	Quantity	Description	Unit Price	Amount
1	1	Commercial Dishwasher as described above		11706 ⁰⁰
2	1	Commercial two-door refrigerator as described above		36415 ⁰⁰
3	1	Commercial walk-in freezer		13191 ⁰⁴
			Total	28543,54

Item	Manufacturer
Commercial Dishwasher	Idobart
Commercial two-door refrigerator	Norlake
Commercial walk-in freezer	American

Includes labor, materials & applicable sales tax

VENDOR PREFERENCE CERTIFICATE

Certification and application* is hereby made for Preference in accordance with West Virginia Code, §5A-3-37. (Does not apply to construction contracts). West Virginia Code, §5A-3-37, provides an opportunity for qualifying vendors to request (at the time of bid) preference for their residency status. Such preference is an evaluation method only and will be applied only to the cost bid in accordance with the West Virginia Code. This certificate for application is to be used to request such preference. The Purchasing Division will make the determination of the Resident Vendor Preference, if applicable.

- 1. Application is made for 2.5% resident vendor preference for the reason checked: Bidder is an individual resident vendor and has resided continuously in West Virginia for four (4) years immediately preceding the date of this certification; or, Bidder is a partnership, association or corporation resident vendor and has maintained its headquarters or principal place of business continuously in West Virginia for four (4) years immediately preceding the date of this certification; or 80% of the ownership interest of Bidder is held by another individual, partnership, association or corporation resident vendor who has maintained its headquarters or principal place of business continuously in West Virginia for four (4) years immediately preceding the date of this certification; or, Bidder is a nonresident vendor which has an affiliate or subsidiary which employs a minimum of one hundred state residents and which has maintained its headquarters or principal place of business within West Virginia continuously for the four (4) years immediately preceding the date of this certification; or,
2. Application is made for 2.5% resident vendor preference for the reason checked: Bidder is a resident vendor who certifies that, during the life of the contract, on average at least 75% of the employees working on the project being bid are residents of West Virginia who have resided in the state continuously for the two years immediately preceding submission of this bid; or,
3. Application is made for 2.5% resident vendor preference for the reason checked: Bidder is a nonresident vendor employing a minimum of one hundred state residents or is a nonresident vendor with an affiliate or subsidiary which maintains its headquarters or principal place of business within West Virginia employing a minimum of one hundred state residents who certifies that, during the life of the contract, on average at least 75% of the employees or Bidder's affiliate's or subsidiary's employees are residents of West Virginia who have resided in the state continuously for the two years immediately preceding submission of this bid; or,
4. Application is made for 5% resident vendor preference for the reason checked: Bidder meets either the requirement of both subdivisions (1) and (2) or subdivision (1) and (3) as stated above; or,
5. Application is made for 3.5% resident vendor preference who is a veteran for the reason checked: Bidder is an individual resident vendor who is a veteran of the United States armed forces, the reserves or the National Guard and has resided in West Virginia continuously for the four years immediately preceding the date on which the bid is submitted; or,
6. Application is made for 3.5% resident vendor preference who is a veteran for the reason checked: Bidder is a resident vendor who is a veteran of the United States armed forces, the reserves or the National Guard, if, for purposes of producing or distributing the commodities or completing the project which is the subject of the vendor's bid and continuously over the entire term of the project, on average at least seventy-five percent of the vendor's employees are residents of West Virginia who have resided in the state continuously for the two immediately preceding years.

Bidder understands if the Secretary of Revenue determines that a Bidder receiving preference has failed to continue to meet the requirements for such preference, the Secretary may order the Director of Purchasing to: (a) reject the bid; or (b) assess a penalty against such Bidder in an amount not to exceed 5% of the bid amount and that such penalty will be paid to the contracting agency or deducted from any unpaid balance on the contract or purchase order.

By submission of this certificate, Bidder agrees to disclose any reasonably requested information to the Purchasing Division and authorizes the Department of Revenue to disclose to the Director of Purchasing appropriate information verifying that Bidder has paid the required business taxes, provided that such information does not contain the amounts of taxes paid nor any other information deemed by the Tax Commissioner to be confidential.

Under penalty of law for false swearing (West Virginia Code, §61-5-3), Bidder hereby certifies that this certificate is true and accurate in all respects; and that if a contract is issued to Bidder and if anything contained within this certificate changes during the term of the contract, Bidder will notify the Purchasing Division in writing immediately.

Bidder: Allied Refrigeration Inc Signed: W. Cannon C. Baller
Date: April 20, 2011 Title: Owner/President

*Check any combination of preference consideration(s) indicated above, which you are entitled to receive.

STATE OF WEST VIRGINIA
Purchasing Division

PURCHASING AFFIDAVIT

West Virginia Code §5A-3-10a states: No contract or renewal of any contract may be awarded by the state or any of its political subdivisions to any vendor or prospective vendor when the vendor or prospective vendor or a related party to the vendor or prospective vendor is a debtor and the debt owed is an amount greater than one thousand dollars in the aggregate.

DEFINITIONS:

"Debt" means any assessment, premium, penalty, fine, tax or other amount of money owed to the state or any of its political subdivisions because of a judgment, fine, permit violation, license assessment, defaulted workers' compensation premium, penalty or other assessment presently delinquent or due and required to be paid to the state or any of its political subdivisions, including any interest or additional penalties accrued thereon.

"Debtor" means any individual, corporation, partnership, association, limited liability company or any other form or business association owing a debt to the state or any of its political subdivisions. "Political subdivision" means any county commission; municipality; county board of education; any instrumentality established by a county or municipality; any separate corporation or instrumentality established by one or more counties or municipalities, as permitted by law; or any public body charged by law with the performance of a government function or whose jurisdiction is coextensive with one or more counties or municipalities. "Related party" means a party, whether an individual, corporation, partnership, association, limited liability company or any other form or business association or other entity whatsoever, related to any vendor by blood, marriage, ownership or contract through which the party has a relationship of ownership or other interest with the vendor so that the party will actually or by effect receive or control a portion of the benefit, profit or other consideration from performance of a vendor contract with the party receiving an amount that meets or exceeds five percent of the total contract amount.

EXCEPTION: The prohibition of this section does not apply where a vendor has contested any tax administered pursuant to chapter eleven of this code, workers' compensation premium, permit fee or environmental fee or assessment and the matter has not become final or where the vendor has entered into a payment plan or agreement and the vendor is not in default of any of the provisions of such plan or agreement.

Under penalty of law for false swearing (*West Virginia Code* §61-5-3), it is hereby certified that the vendor affirms and acknowledges the information in this affidavit and is in compliance with the requirements as stated.

WITNESS THE FOLLOWING SIGNATURE

Vendor's Name: Allred Refrigeration, Inc

Authorized Signature: [Signature] Date: 4/15/2011

State of WV

County of Harrison, to-wit:

Taken, subscribed, and sworn to before me this 15th day of April, 2011.

My Commission expires May 13, 2014.

AFFIX SEAL HERE

NOTARY PUBLIC Marianne Strugarek

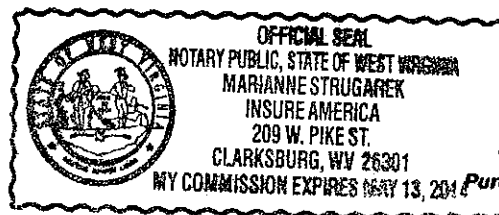

NOR-LAKE, INCORPORATED
 727 Second Street
 P.O. Box 248
 Hudson, Wisconsin 54018

800-955-5253
 715-388-2323
 866-861-5253 Parts
 800-388-5253 Service
 715-388-8149 FAX
 www.norlake.com

NORLAKE

ADVANTEDGE BASEMOUNT REACH-IN REFRIGERATORS

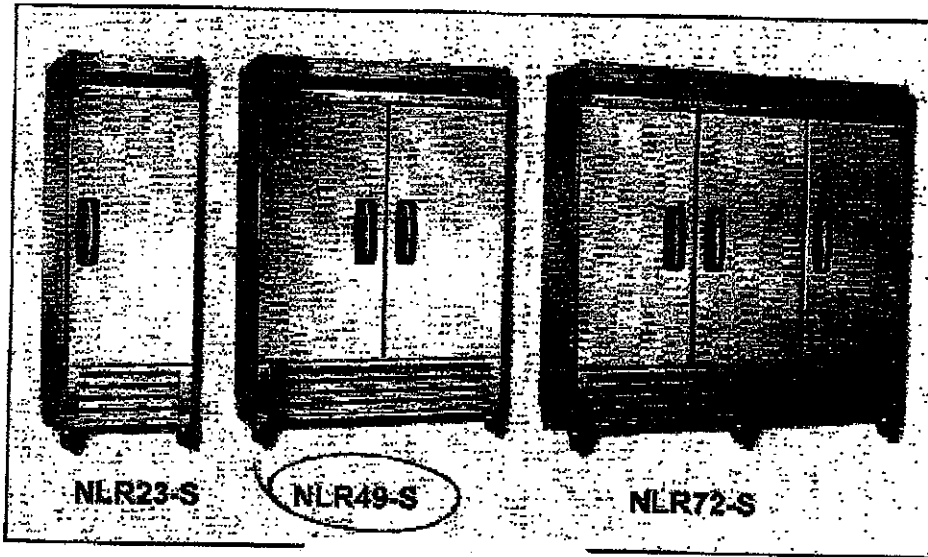

Ann! On 75
 304-622-1460
 284515

PROJECT:

ITEM NUMBER:

MODEL NUMBER:

1, 2 & 3 DOOR ADVANTEDGE BASEMOUNT REFRIGERATOR

SPECIFICATIONS FOR: NLR23-S, NLR49-S, NLR72-S

- **Exterior finish:** Exterior front sides and doors are stainless steel. The exterior top, bottom and back are galvanized steel.
- **Interior finish:** Interior liner and interior door panel are stainless steel
- **Insulation:** The complete cabinet and door(s) are foamed-in-place with polyurethane foam insulation.
- **Hardware:** Heavy duty, pivot hinges; key locks; curved handle with recessed pocket; self adjusting magnetic gaskets; 4" dia. casters (4 casters on one and two door models and 6 casters on three door model). 4 vinyl coated shelves per door section - standard.
- **Electrical:** An interior incandescent light is activated by a switch for each door.
- **Instrumentation:** Microprocessor with digital display allows temperature adjustment at control panel.
- **Refrigeration:** Complete bottom mounted refrigeration system with a copper tube, ceiling mount aluminum fin evaporator. The condensate is collected and automatically evaporated from an energy efficient air over wick style vaporizer. Drain line is recessed in cabinet back. Refrigerant flow is controlled by a capillary tube. R-134a refrigerant. Operating temperature: 38°F.
- **Approvals:** UL listed
 C-UL listed **
 ETL Sanitation

STANDARD FEATURES

- Air-cooled condensing unit
- Automatic condensate vaporizer
- Automatic defrost
- Casters
- Capillary tube system
- Curved handle with recessed pocket
- Door open alarm
- Interior light
- Key locks
- Magnetic gasket

OPTIONAL FEATURES

- Microprocessor with digital display
- Operating temperature: 38°F
- Polyurethane insulation
- R-134a refrigerant
- Stainless steel interior and exterior
- Vinyl coated shelves
- UL, C-UL & ETL Sanitation
- Warranties: 1 year parts labor/service
 5 year compressor
- Extra shelves
- Pan slide rack (part # 146515)



Nor-Lake, Inc.
 Registered to ISO 9001:2008
 File No. 10001816

** C-UL is Underwriters Laboratories Safety Certification Mark which indicates that UL has tested the equipment to applicable CSA Standards.

SPECIFICATION
 GUIDE

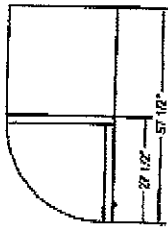

NLR23-S Top View

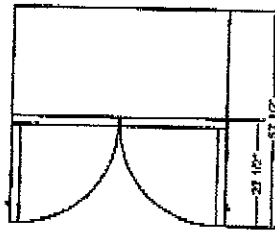

NLR49-S Top View

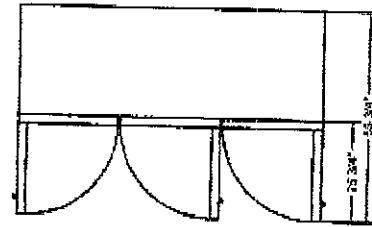

NLR72-S Top View

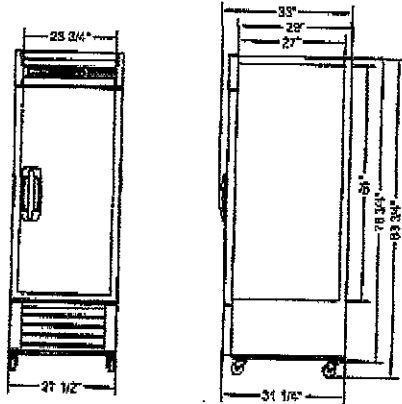

NLR23-S Front and Side Views

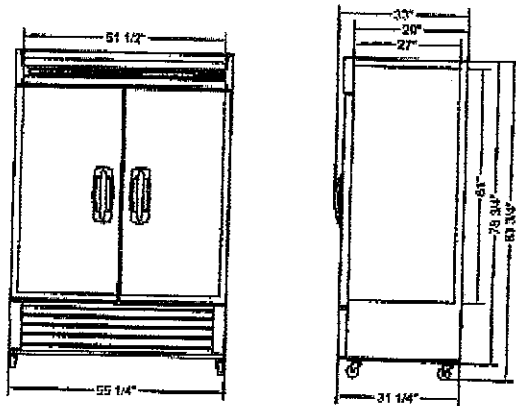

NLR49-S Front and Side Views

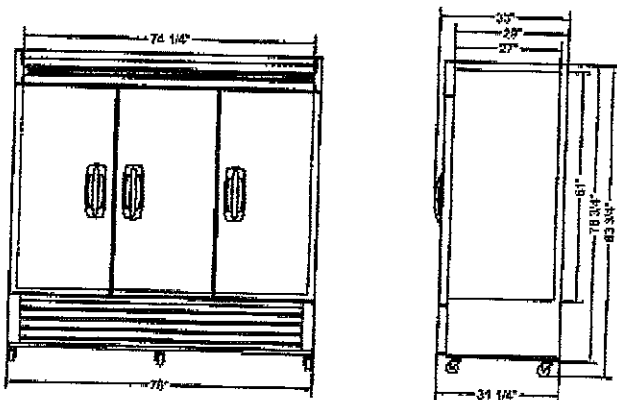

NLR72-S Front and Side Views

SPECIFICATIONS			
	NLR23-S	NLR49-S	NLR72-S
Crated Height	84-1/4"	84-1/4"	84-1/4"
Crated Width	29-1/8"	56-3/4"	78-3/8"
Crated Depth	33-1/2"	33-1/2"	33-1/2"
Crated Weight (lbs)	290	482	632
Interior Height (in)	61"	61"	61"
Interior Width (in)	23-3/4"	51-1/2"	74-1/4"
Interior Depth (in)	27"	27"	27"
Overall Height (in)	83-3/4"	83-3/4"	83-3/4"
Overall Width (in)	27-1/2"	55-1/4"	78"
Overall Depth (in)	33"	33"	33"
Gross Cubage (ft. ³)	23	49	70
Number of Shelves	4	8	12
Number of Casters	4	4	6
Condensing Unit Size	3/8 HP	3/8 HP	1/2 HP
Refrigerant	R-134a	R-134a	R-134a
Electrical Characteristics	115/60/1	115/60/1	115/60/1
Cord & Plug Furnished	Yes	Yes	Yes
NEMA Plug Configuration	5-15P	5-15P	5-15P
Total Amp Draw	7.5	7.5	10

* The overall heights shown in the table and drawings are with casters.

Specifications subject to change without notice.



Revision Date: 5/10
 © 2010 NOR-LAKE, INC.
 Printed in the U.S.A.
 Part Number: 138688



HOBART

701 S Ridge Avenue, Troy, OH 45374
1-888-4HOBART • www.hobartcorp.com

AM SELECT DISHWASHER

HOBART

STANDARD FEATURES

- .74 gallons per rack final rinse water
- 58 racks per hour – hot water sanitizing
- 65 racks per hour – chemical sanitizing
- NSF pot and pan listed for 2-, 4- & 6- minute cycles
- Timed wash cycles for 1, 2, 4 or 6 minutes
- Solid state, integrated controls with digital status indicators
- Self-draining, high efficiency stainless steel pump and stainless steel impeller
- Stainless steel drawn tank, tank shelf, chamber, trim panels, frame and feet
- Spring counterbalanced chamber with polyethylene guides
- Revolving, interchangeable upper and lower anti-clogging wash arms
- Revolving, interchangeable upper and lower rinse arms
- Slanted, self-locating, one-piece scrap screen and basket system
- Automatic fill
- Door actuated start
- Automatic drain closure
- Vent fan control
- External booster activation
- Delime cycle
- Service diagnostics
- NAFEM Data Protocol capable
- Straight-through or corner installation
- Hot water or chemical sanitation

VOLTAGE

- 208-240/60/1
- 208-240/60/3
- 480/60/3
- 200-240/50/3*
- 380-415/50/3*

*Not submitted for UL/CUL Listing

MODEL

- AM15

OPTIONS AT EXTRA COST

- Gas heat
- Sense-A-Temp™ 70°F rise electric booster heater
- Single point electrical connection for booster equipped machines (3 phase only)

ACCESSORIES

- ¾" pressure regulator valve
- Peg rack
- Combination rack
- Splash shield for corner installations
- Flanged and seismic feet
- End of cycle audible alarm (field activated)
- Delime notification (field activated)
- Drain water tempering kit

Specifications, Details and Dimensions on Inside and Back.

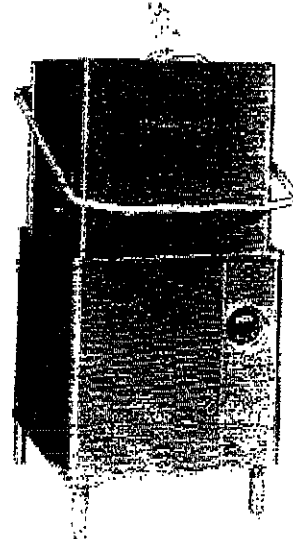

AM SELECT DISHWASHER

AM SELECT DISHWASHER - ELECTRIC

HOBART

701 S Ridge Avenue, Troy, OH 45374
1-888-4HOBART • www.hobartcorp.com

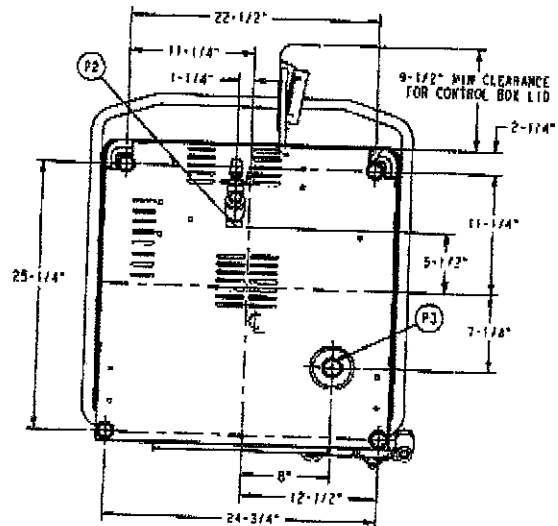
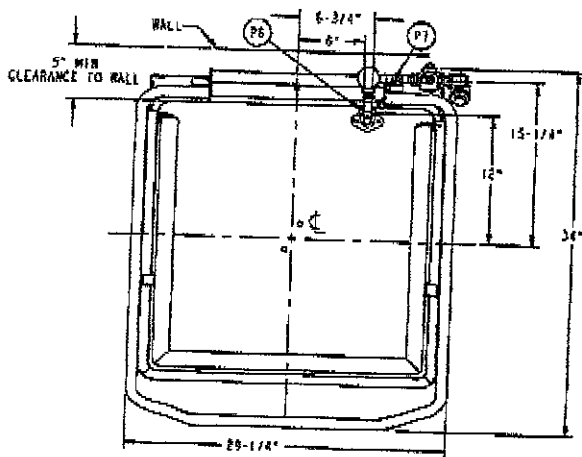
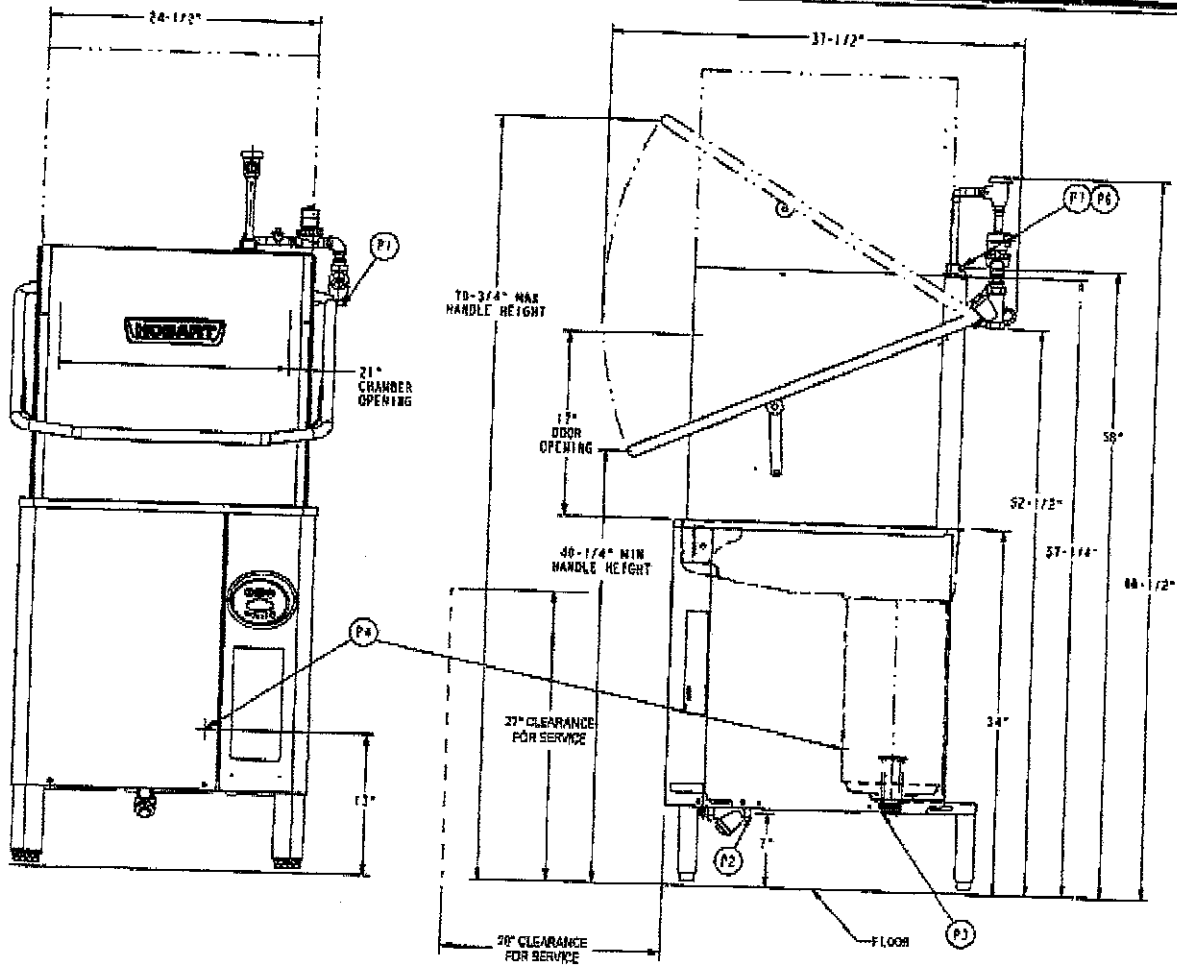

HOBART

701 S Ridge Avenue, Troy, OH 45374
1-888-4HOBART • www.hobartcorp.com

AM SELECT DISHWASHER - ELECTRIC

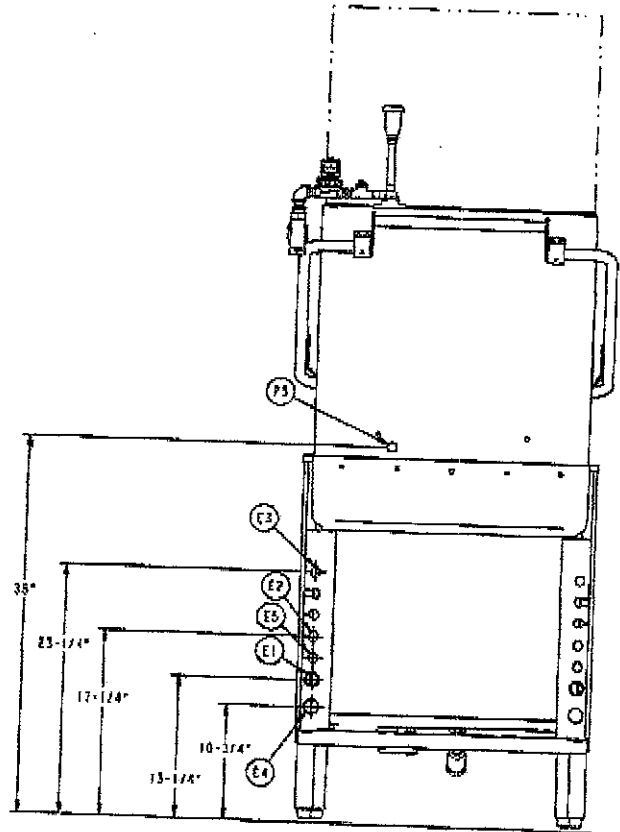
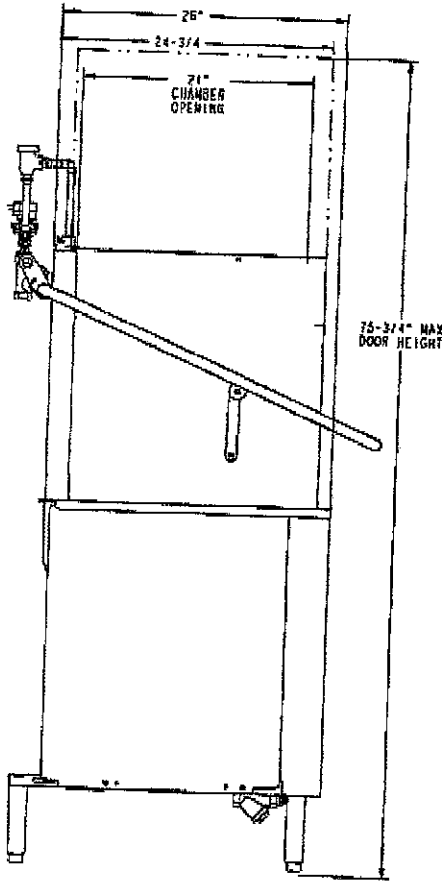

WARNING

ELECTRICAL AND GROUNDING CONNECTIONS MUST COMPLY WITH THE APPLICABLE PORTIONS OF THE NATIONAL ELECTRICAL CODE AND/OR OTHER LOCAL ELECTRICAL CODES.

PLUMBING CONNECTIONS MUST COMPLY WITH APPLICABLE SANITARY, SAFETY, AND PLUMBING CODES.

CONNECTION INFORMATION

4" AFT • ABOVE FINISHED FLOOR

LEGEND (see page 6 for further details)

- E1 ELECTRICAL CONNECTION: MOTORS & CONTROLS (INCLUDING ELECTRIC HEAT). 7" OR 3/4" CONDUIT HOLE.
- E2 ELECTRICAL CONNECTION: HEAT FAN CONTROL. 1/2" CONDUIT HOLE. (EPC1 & EPC2) 1.5 AMPS @ MANIPULATE SUPPLY VOLTAGE. *OR*
- E3 ELECTRICAL CONNECTION: RINSE AGENT & SANITIZER FEEDERS. 1/2" CONDUIT HOLE. (DPS1 & DPS2) 1.5 AMPS @ MANIPULATE SUPPLY VOLTAGE. (RPS1 & RPS2) 1.5 AMPS @ MANIPULATE SUPPLY VOLTAGE.
- E4 ELECTRICAL CONNECTION: ELECTRIC BOOSTER. (NOT AVAILABLE WITH GAS HEAT MACHINE) 1" CONDUIT HOLE.
- E5 ELECTRICAL CONNECTION: EXTERNAL BOOSTER CONTROL. 1/2" CONDUIT HOLE. (BSTR1 & BSTR2) 0.1 AMPS @ 100 VAC.
- P1 COMMON WATER CONNECTION: (W/O ELECTRIC BOOSTER) 1/2" COMMON WATER CONNECTION: (W/EO ELECTRIC BOOSTER) 1/2" WATER MIN. CHEMICAL SANITIZING) 3/4" FPT.
- P2 COMMON WATER CONNECTION: (W/ELECTRIC BOOSTER) 1/2" WATER MIN. (HOT WATER SANITIZING); 3/4" FPT.
- P3 DRAIN: 1-1/2" NPT.
- P4 DETERGENT PROOF SENSOR: REMOVE CAP AND SPD ASSEMBLY TO ACCESS 7/8" HOLE.
- P5 DETERGENT FEEDER: REMOVE CAP PLUG TO ACCESS 7/8" HOLE.
- P6 RINSE AGENT FEEDER: 1/8" NPT. REMOVE 1/8" NPT PIPE PLUG TO ACCESS TAPPED HOLE.
- P7 SANITIZER FEEDER: (LOW TEMP MODE) 1/8" NPT. REMOVE 1/8" NPT PIPE PLUG TO ACCESS TAPPED HOLE.

AM-15 WITH ELECTRIC HEAT			
ELEC. SPECS.	RATED AMPS	MINIMUM SUPPLY CIRCUIT CONDUCTOR CAPACITY	MAXIMUM OVERCURRENT PROTECTIVE DEVICE
208-240/60/1	43.0	50	50
208-240/60/3	24.6	30	30
480/60/3	11.8	15	15
208-240/50/3	23.2	30	30
380-415/50/3	12.5	15	15

MACHINE ELECTRICAL SPECIFICATIONS

208-240/60/1
208-240/60/3
480/60/3

* 208-240/50/3
* 380-415/50/3

* THESE ELECTRICAL SPECIFICATIONS ARE NOT SUBMITTED FOR UL OR CSA LISTING

BOOSTER CAPACITY RATINGS (SKW) (NOT AVAILABLE WITH GAS HEAT)			
ELEC. SPECS.	RATED AMPS	MINIMUM SUPPLY CIRCUIT CONDUCTOR CAPACITY	MAXIMUM OVERCURRENT PROTECTIVE DEVICE
208-240/60/1	35.4	50	50
208-240/60/3	20.4	30	30
480/60/3	10.2	15	15
*208-240/50/3	20.4	30	30
*380-415/50/3	11.8	15	15

BOOSTER ELECTRICAL SPECIFICATIONS

208-240/60/1
208-240/60/3
480/60/3

* 208-240/50/3
* 380-415/50/3

* THESE ELECTRICAL SPECIFICATIONS ARE NOT SUBMITTED FOR UL OR CSA LISTING

AM SELECT DISHWASHER

HOBART

701 S Ridge Avenue, Troy, OH 45374
1-888-4HOBART • www.hobartcorp.com

ELECTRIC TANK HEAT

PLUMBING NOTES:

WATER HAMMER ARRESTOR (MEETING ASSE-1010 STANDARD OR EQUIVALENT) TO BE SUPPLIED (BY OTHERS) IN COMMON WATER SUPPLY LINE AT SERVICE CONNECTION.

RECOMMENDED WATER HARDNESS TO BE 4-6 GRAINS FOR BEST RESULTS.

RECOMMENDED BUILDING FLOWING WATER PRESSURE TO THE DISHWASHER IS 15-25 PSI. IF PRESSURES HIGHER THAN 25 PSI ARE PRESENT, A PRESSURE REGULATING VALVE WITH INTERNAL THERMAL EXPANSION BY PASS, MUST BE SUPPLIED (BY OTHERS) IN THE WATER LINE TO THE DISHWASHER.

FOR CONVENIENCE WHEN CLEANING, WATER TAP SHOULD BE INSTALLED NEAR MACHINE WITH HEAVY DUTY NOSE AND SQUEEZE VALVE.

MISCELLANEOUS NOTES:

ALL DIMENSIONS TAKEN FROM FLOOR LINE MAY INCREASE 3/4" OR DECREASE 1/2" DEPENDING ON LEG ADJUSTMENT.

NET WEIGHT OF MACHINE: 274 LBS. W/O BOOSTER
DOMESTIC SHIPPING WEIGHT: 354 LBS. W/O BOOSTER

NET WEIGHT OF MACHINE: 304 LBS. W/BOOSTER
DOMESTIC SHIPPING WEIGHT: 384 LBS. W/BOOSTER

SIZE OF RACKS - 19-3/4" x 19-3/4"

DRAIN LEVER LOCATED INSIDE TANK.

VENT HOOD (IF REQUIRED) TO PROVIDE A MINIMUM 450 CFM EXHAUST

(SEE INSTALLATION INSTRUCTIONS).

SINGLE POINT ELECTRICAL CONNECTION AVAILABLE ON 3 PH MACHINES ONLY WITH INTEGRATED BOOSTER HEATER.

OPTIONAL AM SELECT SINGLE POINT ELECTRICAL SERVICE CONNECTION AS SHOWN BELOW

ELEC. SPECS	RATED AMPS	MINIMUM SUPPLY CONDUCT OR AMPACITY	MAXIMUM PROTECTIVE DEVICE
ZOB-240/80/3	45.4	60	60
480/60/3	23.6	30	30
*200-240/50/3	45.7	60	60
*380-475/50/3	25.2	30	30

GAS TANK HEAT

GAS HEATED DISHWASHERS

FOR NATURAL GAS, PRESSURE TO THE BURNER (CUSTOMER CONNECTION) SHOULD NOT EXCEED 7" W.C.

FOR LIQUIFIED PETROLEUM GAS, PRESSURE TO THE BURNER (CUSTOMER CONNECTION) SHOULD NOT EXCEED 11" W.C.

IF GAS PRESSURE IS HIGHER THAN 7" (NATURAL GAS) OR 11" (L.P.G.) W.C., A PRESSURE REGULATING VALVE MUST BE INSTALLED (BY OTHERS) IN THE GAS LINE TO THE DISHWASHER.

GAS HEAT BTU INPUT - 25,000 NATURAL
25,000 PROPANE

PLUMBING NOTES:

WATER HAMMER ARRESTOR (MEETING ASSE-1010 STANDARD OR EQUIVALENT) TO BE SUPPLIED (BY OTHERS) IN COMMON WATER SUPPLY LINE AT SERVICE CONNECTION.

RECOMMENDED WATER HARDNESS TO BE 4-6 GRAINS FOR BEST RESULTS.

RECOMMENDED BUILDING FLOWING WATER PRESSURE TO THE DISHWASHER IS 15-25 PSI. IF PRESSURES HIGHER THAN 25 PSI ARE PRESENT, A PRESSURE REGULATING VALVE WITH INTERNAL THERMAL EXPANSION BY PASS, MUST BE SUPPLIED (BY OTHERS) IN THE WATER LINE TO THE DISHWASHER.

FOR CONVENIENCE WHEN CLEANING, WATER TAP SHOULD BE INSTALLED NEAR MACHINE WITH HEAVY DUTY NOSE AND SQUEEZE VALVE.

MISCELLANEOUS NOTES:

ALL DIMENSIONS TAKEN FROM FLOOR LINE MAY INCREASE 3/4" OR DECREASE 1/2" DEPENDING ON LEG ADJUSTMENT.

NET WEIGHT OF MACHINE: 306 LBS.
DOMESTIC SHIPPING WEIGHT: 386 LBS.

SIZE OF RACKS - 19-3/4" x 19-3/4"

DRAIN LEVER LOCATED INSIDE TANK.

VENT HOOD (IF REQUIRED) TO PROVIDE A MINIMUM 450 CFM EXHAUST (SEE INSTALLATION INSTRUCTIONS).

	AM Select	
	Hot Water Sanitizing	Chemical Sanitizing
Machine Ratings (Mechanical) Racks per Hour (Max.)	58	65
Dishes per Hour (Average 25 per rack)	1,450	1,625
Glasses per Hour (Average 45 per rack)	2,610	2,925
Table to Table - Inside Tank at Table Connection (Inches)	25 1/4"	25 1/4"
Overall Dimensions - (H x W x D) (Inches)	66.5" x 27" x 29.5"	
Wash Motor H.P.	2	2
Wash Tank Capacity - Gallons	14	14
Wash Pump Capacity - Gallons per Minute - Wet Test	180	160
Heating Equipment - (For keeping power wash water hot) Gas Burner (Regulated) Natural/LP Gas BTU/Hr.	25,000	25,000
Electric Heating Unit (Regulated)	8 kw	5 kw
Rinse - Minutes operated during hour of capacity operation	9.68	10.83
Seconds of rinse per rack	10	10
Rate of Rinse Flow - Gallons per Minute - at 20 lbs. Flow Pressure	4.4	4.4
Rinse Consumption - Gallons per Hour - Maximum - at 20 lbs. Flow Pressure	42.9	48.1
Rinse Cycle - Gallons per Rack - at 20 PSI Flow	.74 - 180°F Min.	.74 - 140°F Min.
Steam Booster, if used based on 20 PSI steam - 20 PSI water flowing 180°F entering water raised to 180°F min. (50°F rise) - Lbs. per Hour	40	40
Peak Rate of Drain Flow - Gallons per Minute (initial rate with full tank)	38	38
Exhaust Requirements	450	450
Shipping Weight Grated - Approx. lbs. - Unit only, with booster	354 w/o Booster 384 w/Booster	354

AM SELECT DISHWASHER

HOBART

701 S Ridge Avenue, Troy, OH 45374
1-888-4HOBART • www.hobartcorp.com

The microcomputer-based control system is built into the AM Select dishwasher. It is available in standard electrical specifications of 208-240/60/1, 208-240/60/3, 480/60/3, 200-240/50/3, 380-415/50/3 and is equipped with a reduced voltage pilot circuit transformer.

***CAUTION: CERTAIN MATERIALS, INCLUDING SILVER, ALUMINUM AND PEWTER ARE ATTACKED BY SODIUM HYPOCHLORITE (LIQUID BLEACH) IN THE CHEMICAL SANITIZING DISHWASHER MODE OF OPERATION. WATER HARDNESS MUST BE CONTROLLED TO 4-6 GRAINS FOR BEST RESULTS.**

CONSTRUCTION: Drawn tank, tank shelf and feet constructed of 16 gauge stainless steel. Wash chamber and front trim panel above motor compartment are polished, satin finish. Frame is 12 gauge stainless steel, chamber is 18 gauge, and removable trim panels are 20 gauge.

CHAMBER LIFT: Chamber coupled by stainless steel handle, spring counterbalanced. Chamber guided for ease of operation and long life.

PUMP: With stainless steel pump and impeller, integral with motor assures alignment and quiet operation. Pump shaft seal with stainless steel parts and a carbon ceramic sealing interface. Easily removable impeller housing permits ease of inspection. Capacity 160 GPM. Pump is completely self-draining.

MOTOR: Built for Hobart, 2 H.P., with inherent thermal protection, grease-packed ball bearings, splash-proof design, ventilated. Single-phase is capacitor-start, induction-run type. Three-phase is squirrel-cage, induction type.

MICROCOMPUTER CONTROL SYSTEM: Hobart microcomputer controls, assembled within water-resistant enclosure, provide built-in performance and reliability.

The microcomputer control, relays and contactors are housed behind a stainless steel enclosure, hinged to provide easy access for servicing. The line voltage electrical components are completely wired with 105°C, 600V thermoplastic insulated wire with stranded conductors and routed through listed electrical conduit. Electrical components are wired with type ST cord. Line disconnect switch NOT furnished.

CYCLE OPERATION: The microcomputer-timing program is started by closing the doors, which actuates the door cycle switch. The microcomputer energizes the wash pump motor contactor during the wash portion of the program. After the wash, a dwell permits the upper wash manifold to drain. At the end of the dwell, the final rinse solenoid valve is energized. After the final rinse valve closes, Sani-Dwell (Hot Water Mode only) permits sanitization to continue. The Rinse display remains on during this period, completing the program. If the microcomputer is interrupted during a cycle by the door-cycle switch, the microcomputer is reset to the beginning of the program. **Hot Water Sanitizing (55 racks per hour) - 57 seconds:** 38 Second Wash, 2 Second Dwell, 10 Second Rinse, 7 Second Sani-Dwell. **Chemical Sanitizing (65 racks per hour) - 50 Seconds:** 38 Second Wash, 2 Second Dwell, 10 Second Rinse. Other programs can be pre-selected by your Hobart service technician.

Manual wash cycle selector also provides selection of 2-, 4- or 6-minute wash cycles for heavier washing applications.

WASH: Hobart revolving stainless steel wash arms with unrestricted openings above and below provide thorough distribution of water jets to all dishware surfaces. Arms are easily removable for cleaning and are interchangeable. Stainless steel tubing manifold connects upper and lower spray system.

RINSE: Rotating rinse arms, both upper and lower, feature 14 rinse nozzles. The stainless steel upper and lower rinse arms are easily removable without tools for inspection and are interchangeable. Diaphragm-type rinse control solenoid valve mounted outside machine. Machine is equipped with special hot water vacuum breaker on downstream side of rinse valve - mounted 6" above uppermost rinse opening. Easy open brass line strainer furnished.

FILL: Microcomputer controlled fill valve installed on upstream side of rinse vacuum breaker. Ratio fill method is used giving the correct fill at any flowing water pressure. (20 PSIG minimum necessary for proper rinsing.)

DRAIN AND OVERFLOW: Large bell type automatic overflow and drain valve controlled from inside of machine. Drain automatically closed by lowering chamber. Drain seal is large diameter, high temperature "O" ring. Cover for overflow is integral part of the standpipe.

STRAINER SYSTEM: Equipped with large, exclusive self-flushing, easily removable perforated stainless steel, one-piece strainer and large capacity scrap basket. Submerged scrap basket minimizes frequent removal and cleaning.

HEATING EQUIPMENT: Standard tank heat is 5KW electric immersion heating element. Regulated power infrared gas immersion tube system is optional at extra cost. A solid-state igniter board controls the gas valve and provides flame ignition. A transformer steps the control circuit voltage down to 24 volts to power the igniter board and gas valves.

Gas Heated Dishwasher: For natural gas, gas pressure (customer connection) not to exceed 7" W.C. For liquefied petroleum, gas pressure to burner (customer connection) not to exceed 11" W.C. If gas pressure is higher than 7" W.C. natural or 11" W.C. LP, a pressure regulating valve must be supplied (by others) in the gas line to the dishwasher. Water temperature regulation is controlled by thermistor sensor in combination with microcomputer controls. The tank heat and positive low water protection microcomputer circuits are automatically activated when the main power switch is turned "on". If tank is accidentally drained, low water protection device automatically turns heat off. Gas immersion tube is additionally protected by a high limit device mounted on the surface of the tube. These features are standard with the Hobart Microcomputer Control System.

OPTIONAL EQUIPMENT AT EXTRA COST - ELECTRIC BOOSTER HEATER: Electric booster with Sense-A-Temp™ technology adequately sized to raise 110°F inlet water to 180°F (not available on gas heat machines).

ACCESSORIES: 19½" x 19½" peg and combination dish racks. Splash shield for corner installations. End of cycle audible alarm (field activated). Delime notification (field activated). Desirable functional accessories can be furnished at added cost. See listed options and accessories on this specification sheet. Write to the factory for special requirements not listed above.

As continued product improvement is a policy of Hobart, specifications are subject to change without notice.

HOBART

701 S Ridge Avenue, Troy, OH 45374
1-888-4HOBART • www.hobartcorp.com

AM SELECT DISHWASHER

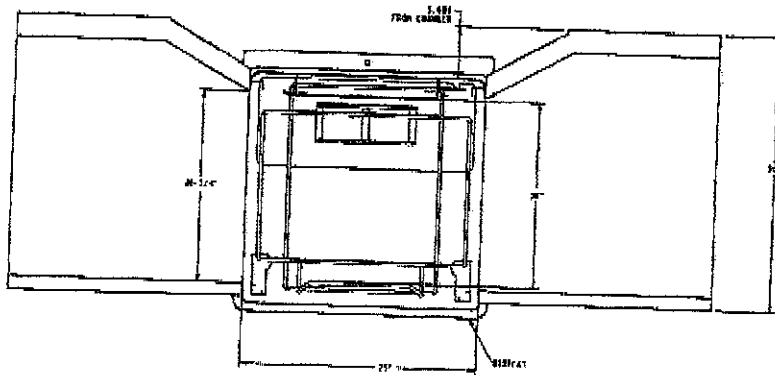

PASS THRU INSTALLATION

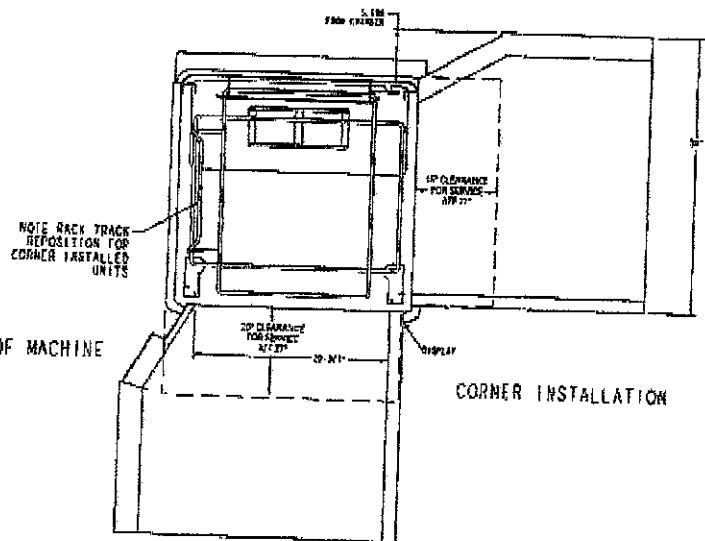

TOP INSIDE VIEW OF MACHINE

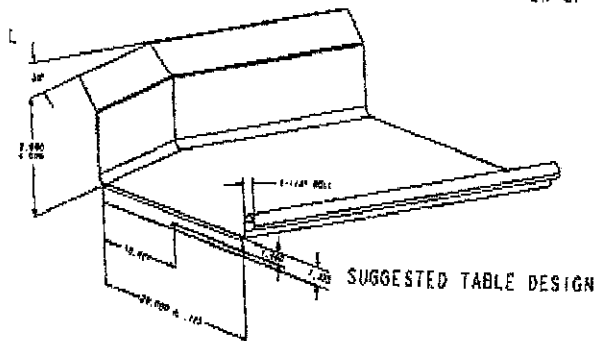

SUGGESTED TABLE DESIGN

- DRILL ϕ .344 HOLE THRU TANK WALL
- 5/16-18 SST TRUSS HD SCREW
- 5/16-18 SST LOCKWASHER
- 5/16-18 SST HEX HD NUT

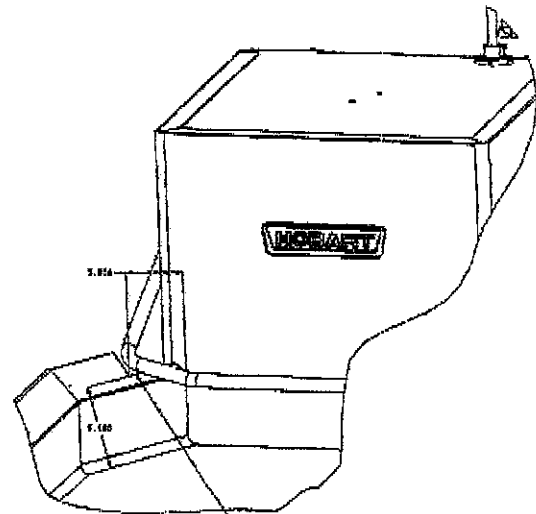
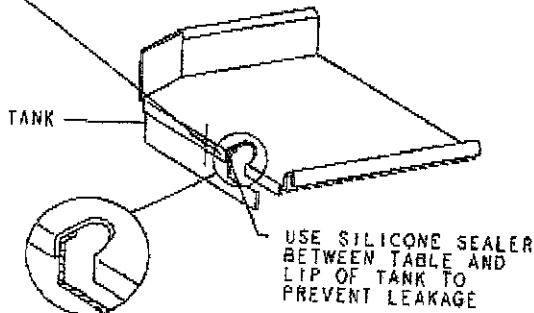

A NOTCH MUST BE ADDED TO OVERCLOSURES OVER 6" HIGH ON CORNER MACHINES TO PREVENT INTERFERENCE WITH DOOR MECHANISM. NOTCH MUST EXTEND 5" FROM FACE OF THE MACHINE.



SALES AGREEMENT

TWO LOCATIONS TO SERVE YOU

7739 E. Broadway Blvd. #125 Tucson, Arizona 85710
 6615 Nineteen Mile Road Sterling Heights, Michigan 48314
 Websites: www.americanwalkincoolers.com

Toll Free: 800.430.4468
 Fax: 520.546.7510

4/7/2011

QUOTE # 52303 - 1264

VERSION # 1

Ship to Address:
 Allied Refrigeration
 Attn: Chris *GARY*
 Anmoore, WV 26323
 304-669-0520 fx. 304-622-1460

Quantity	Description	Amount
----------	-------------	--------

Model #: WSF - AWIC Series IV Walk-In Storage Freezer (-10)
 Overall Dimensions: 5'-10"x11'-7"x6'6"H firm

AWIC Cabinet Features Include:

- 1
 - 4" thick PPC® (Premium Panel Construction) high-density extruded insulation freezer panels ; "exceeds" new EISA energy standards. PPC® eliminates need for perimeter wood framing providing higher R-value. All panels include: National approvals - UL-NSF Approved / Smoke & Flame Spread as per ASTM E84 testing. Premium "white" metal finish in/out (no extra charge)
 - 4 1/2" thick reinforced insulated floor in freezer, Stainless steel finish with integrated NSF Stainless Steel Coving and cam locked walls to floor
 - 34"x78" UL approved "Super-Door" package (freezer with heat). Flush mount door, energy saving vapor proof CFL lamp pre-wired to exterior switch, exterior digital thermometer, self-closing hinges, door closure, 3 strap hinges, dart mount magnetic seal gasket, aluminum diamond tread kickplates installed on lower portion of door (interior & exterior)
 - 2" x 3" vertical wall trim strips (seals box to adjacent walls)
 - Heated pressure relief port

AWIC Refrigeration System Includes:

- 1
 - RL200-PR Low Temp Outdoor 2 1/2 HP w/Pump-down Controls. Pre-assembled outdoor condensing unit, UL approved, headmaster low ambient control. Freezer: NSF-UL Approved low-silhouette evaporator coil(s) with electric defrost 208/230v
 - All control components, filter driers and /or valves provided as part of system
 - Select electrical voltage and phase of condensing unit: (208-230v, 1 or 3 phase)
 - Note: See enclosed "ASHRAE SYSTEM SPEC" for complete details of system warranty: • 5 Year Compressor Motor • 1 Year Parts • No Labor warranty ("self install")
 - Customer is responsible for all installation and future repair/replacement labor expense.
 - See computer drawing for electrical requirements

Buyer's Acceptance

Date

AWIC Signature

4/7/11

Date



SALES AGREEMENT

TWO LOCATIONS TO SERVE YOU

7739 E. Broadway Blvd. #125 6615 Nineteen Mile Road
Tucson, Arizona 85710 Sterling Heights, Michigan 48314

Websites: www.americanwalkincoolers.com

Toll Free: 800.430.4468
Fax: 520.546.7510

Total *Delivered Price*** Of Above Materials**

Note: For Walk-in Orders – Receipt, Inspection, Installation and Labor Warranty by Others

Terms: 50% Deposit; Balance Due Upon Shipping

Delivery: 3 Weeks; Sooner If Possible

Buyer's Acceptance	Date	AWIC Signature	4/7/11 Date
--------------------	------	----------------	----------------

FAX MAIL

FROM

American Walk-in Coolers

Tel. (520) 722-4468

Fax (520) 546-7510

Toll Free (800) 430-4468

TO:

GARY

FROM:

GENE

DATE:

4-7-11

PAGES:

COMMENTS

SEE ATTACHED FREEZER
QUOTE

*Nationwide & International
Walk-in Refrigeration Equipment
Sales, Service and Installations*

American Walk-in Coolers
Website: www.americanwalkincoolers.com
Email: gene@awic.ws

Tygart Lake State Park
 Rt. 1 Box 250
 Crafton, WV 26334
 (304) 265-6144
 fax (304) 265-6149

The West Virginia Purchasing Division for the West Virginia Division of Natural Resources is requesting bids for the purchase and installation of one (1) Commercial dishwasher, one (1) Commercial two door reach-in refrigerator and one (1) Commercial, single-unit, walk-in freezer. This order will not be split. All pieces will be awarded to one successful bidder.

All items are to be F.O.B. Destination. Freight or delivery charges must be no charge or included in the price of the goods.

General Specifications:

- All items must be manufactured for commercial use.
- Successful bidder responsible for removal & proper disposal of all old equipment from facility.
- All items must be off loaded, completely assembled, installed and ready for use by the facility.
- All items must be 2011 model year or newer.
- Bidders must provide a Manufacturer specifications document for each item.
- Suggest all bidders do a site visit.
- Successful bidder must be a registered vendor with the State of West Virginia.
- The contractor and/or any subcontractors must pay West Virginia Division of Labor prevailing wage rates as established for Taylor County, pursuant to W. Va. Code §21-54, et. seq.
- The entire scope of work is the responsibility of the successful bidder.

Damaged Items:

Damaged or defective items must be replaced at no additional expense to the West Virginia Division of Natural Resources.

Warranties:

Warranties must be a minimum of one year parts and labor. However, if the manufacturer warranty periods are longer than the required minimum, those warranties shall apply.

Commercial Dishwasher:

The Commercial dishwasher must meet the following specifications:

- Minimum dimensions of 24" D x 24 1/2" W x 60" H
- Maximum dimensions of 25" D x 25 1/2" x 60" H
- Commercial Dishwasher, door type, high-temperature sanitizing.
- Built in booster heater.
- Straight through design.
- 60 racks/hour.
- Stainless steel construction.
- Electric tank heat.
- Auto fill.
- One open rack.
- One peg rack.
- Drain water tempering kit.
- Energy Star Rated.
- Three phase electricity.

Commercial two door refrigerator:

The Commercial two door refrigerator must meet the following specifications:

- * Two-door, reach in design.
- * Air cooled, condensing unit.
- * Bottom mounted refrigeration system.
- * Automatic condensate vaporizer.
- * Automatic defrost.
- * Casters
- * Capillary tube system.
- * Door open alarm.
- * Interior light.
- * Key locks.
- * Magnetic gasket.
- * Microprocessor with digital display.
- * Operating temperature 38 deg. F.
- * Polyurethane insulation.
- * R-134-a refrigerant or equal.
- * Stainless steel interior.
- * Stainless steel exterior.
- * Vinyl coated shelves
- * UL, C-UL & ETL Sanitation.
- * Minimum dimensions of 62 1/4" H x 54 1/4" W x 32" D.
- * Maximum dimensions of 84 1/4" H x 56 1/4" W x 34" D.
- * Forty nine cubic feet or larger.

Commercial walk-in freezer:

The Commercial walk-in freezer must meet the following specifications:

- Commercial Indoor Walk-in Freezer with floor.
- Insulation: Minimum 4-inch foamed-in-place urethane (X) Class I
- Maximum Dimensions of 5'10" x 11'7" x 6'6-1/2" H.
- Minimum Dimensions of 5'9" x 11'6" x 6'5 1/2" H.
- Interior & Exterior 26 Ga. stainless galvanized.
- Interior Floor 18 Ga. Stainless Steel.
- Entrance Door: 34" x 66" with door closer included.
- VXS-CFL compact fluorescent light or similar.
- Weiss 24DT-SP-LT digital thermostat or equal.
- 115v pressure relief port.
- Non-skid strips every 6"
- Refrigeration:
 - QHA-0004L4-1SE-02 (5400 btuh) - 10F holding temp @ 95 deg F amb.
 - TPO 20-ft lines.
 - Air Cooled.
 - R-404A.
 - Outdoor.
 - Weather Cover.
 - Low Amb control.
 - Full hermetic.
 - 0250 low 2-1/2 hp
 - Voltage: 208/230-1-50
 - Condensing Unit: With PSC motors or equal.
 - Evaporator: With SE24-93 w/ECM motors or equal.
 - To be mounted on building foot by successful bidder.
 - Three phase electricity.