



State of West Virginia
 Department of Administration
 Purchasing Division
 2019 Washington Street East
 Post Office Box 50130
 Charleston, WV 25305-0130

Request for Quotation

RFQ NUMBER:
DNRB11155

PAGE:
8

ADDRESS CORRESPONDENCE TO ATTENTION OF:
**FRANK WHITTAKER
 304-558-2316**

RFQ COPY
 TYPE NAME/ADDRESS HERE

PURCHASER

WARD'S INC.
 CONTRACTOR LICENSE #WV009304
 (304) 623-6646 FAX (304) 623-6647
 ST. ROUTE 58, P.O. BOX 179
 ANMOORE, WV 26323

SHIP TO

**DIVISION OF NATURAL RESOURCES
 TYGART LAKE STATE PARK
 ATTN: PARK SUPERINTENDENT
 ROUTE 1, BOX 260
 GRAFTON, WV
 26354 265-3383**

DATE	SHIP VIA	FOB	FREIGHT TERMS
03/23/2011			

BID OPENING DATE: **04/26/2011** BID OPENING TIME: **01:30PM**

LINE	QUANTITY	UOP	CAT NO	ITEM NUMBER	UNIT PRICE	AMOUNT
<p>OR ALTERS THE INFORMATION PROVIDED FROM THE SOURCES AS DESCRIBED IN THE ABOVE PARAGRAPH IS VOID AND OF NO EFFECT.</p> <p>BANKRUPTCY: IN THE EVENT THE VENDOR/CONTRACTOR FILES FOR BANKRUPTCY PROTECTION, THE STATE MAY DEEM THE CONTRACT NULL AND VOID, AND TERMINATE SUCH CONTRACT WITHOUT FURTHER ORDER.</p> <p>REV. 5/2009</p> <p style="text-align: center;">NOTICE</p> <p>A SIGNED BID MUST BE SUBMITTED TO:</p> <p style="text-align: center;">DEPARTMENT OF ADMINISTRATION PURCHASING DIVISION BUILDING 15 2019 WASHINGTON STREET, EAST CHARLESTON, WV 25305-0130</p> <p>THE BID SHOULD CONTAIN THIS INFORMATION ON THE FACE OF THE ENVELOPE OR THE BID MAY NOT BE CONSIDERED:</p> <p>SEALED BID</p> <p>BUYER: 44</p> <p>REQ. NO.: DNRB11155</p> <p>BID OPENING DATE: 04/26/2011</p> <p>BID OPENING TIME: 1:30 PM</p>						

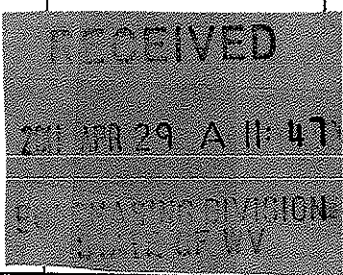

SEE REVERSE SIDE FOR TERMS AND CONDITIONS

SIGNATURE: *Frank R. Hutt* TELEPHONE: **304-623-6646** DATE: **4-25-11**

TITLE: *Sales Mgr* FEIN: **550579928** ADDRESS CHANGES TO BE NOTED ABOVE

WHEN RESPONDING TO RFQ, INSERT NAME AND ADDRESS IN SPACE ABOVE LABELED 'VENDOR'



State of West Virginia
 Department of Administration
 Purchasing Division
 2019 Washington Street East
 Post Office Box 50130
 Charleston, WV 25305-0130

Request for Quotation

RFQ NUMBER
DNRB11155

PAGE
9

ADDRESS CORRESPONDENCE TO ATTENTION OF
FRANK WHITTAKER
304-558-2316

RFQ COPY
 TYPE NAME/ADDRESS HERE

VENDOR

SHIP TO

DIVISION OF NATURAL RESOURCES
 TYGART LAKE STATE PARK
 ATTN: PARK SUPERINTENDENT
 ROUTE 1, BOX 260
 GRAFTON, WV
 26354 265-3383

DATE PRINTED	TERMS OF SALE	SHIP VIA	F.O.B.	FREIGHT TERMS
03/23/2011				

BID OPENING DATE: **04/26/2011** BID OPENING TIME **01:30PM**

LINE	QUANTITY	UOP	CAT. NO.	ITEM NUMBER	UNIT PRICE	AMOUNT
PLEASE PROVIDE A FAX NUMBER IN CASE IT IS NECESSARY TO CONTACT YOU REGARDING YOUR BID: <u>304-623-6647</u>						
PLEASE PRINT OR TYPE NAME OF PERSON TO CONTACT CONCERNING THIS QUOTE: <u>Gary R. Hitt</u>						
***** THIS IS THE END OF RFQ DNRB11155 ***** TOTAL:						<u>* 25,000.00</u>

SEE REVERSE SIDE FOR TERMS AND CONDITIONS

SIGNATURE Gary R. Hitt TELEPHONE 304-623-6646 DATE 4-25-11
 TITLE Sales Mgr FEIN 550579928 ADDRESS CHANGES TO BE NOTED ABOVE

WHEN RESPONDING TO RFQ, INSERT NAME AND ADDRESS IN SPACE ABOVE LABELED 'VENDOR'

Tygart Lake State Park
 Rt. 1 Box 260
 Grafton, WV 26354
 (304) 265-6144
 fax (304) 265-6149

The West Virginia Purchasing Division for the West Virginia Division of Natural Resources is requesting bids for the purchase and installation of one (1) Commercial dishwasher, one (1) Commercial two door reach-in refrigerator and one (1) Commercial, single-unit, walk-in freezer. This order will not be split. All pieces will be awarded to one successful bidder.

All items are to be F.O.B. Destination. Freight or delivery charges must be no charge or included in the price of the goods.

General Specifications:

- All items must be manufactured for commercial use.
- Successful bidder responsible for removal & proper disposal of all old equipment from facility.
- All items must be off loaded, completely assembled, installed and ready for use by the facility.
- All items must be 2011 model year or newer.
- Bidders must provide a Manufacturers specifications document for each item.
- Suggest all bidders do a site visit.
- Successful bidder must be a registered vendor with the State of West Virginia.
- The contractor and/or any subcontractors must pay West Virginia Division of Labor prevailing wage rates as established for Taylor County, pursuant to W.Va. Code §21-5A, et. seq.
- The entire scope of work is the responsibility of the successful bidder.

Damaged Items:

Damaged or defective items must be replaced at no additional expense to the West Virginia Division of Natural Resources.

Warranty:

Warranties must be a minimum of one year parts and labor. However, if the manufacturer warranty periods are longer than the required minimum, those warranties shall apply.

Commercial Dishwasher:

The Commercial dishwasher must meet the following specifications:

- Minimum dimensions of 24"D x 24½"W x 59"H
- Maximum dimensions of 25"D x 25½" x 60"H
- Commercial Dishwasher, door type, high temperature sanitizing.
- Built in booster heater.
- Straight through design.
- 60 racks/hour.
- Stainless steel construction.
- Electric tank heat.
- Auto fill.
- One open rack.
- One-peg rack.
- Drain water tempering kit.
- Energy Star Rated.
- Three phase electricity.

Commercial two door refrigerator:

The Commercial two door refrigerator must meet the following specifications:

- Two-door, reach in design.
- Air cooled condensing unit.
- Bottom mounted refrigeration system.
- Automatic condensate vaporizer.
- Automatic defrost.
- Casters
- Capillary tube system.
- Door open alarm.
- Interior light.
- Key locks.
- Magnetic gasket.
- Microprocessor with digital display.
- Operating temperature 38 deg. F.
- Polyurethane insulation.
- R-134-a refrigerant or equal.
- Stainless steel interior.
- Stainless steel exterior.
- Vinyl coated shelves
- ULC-UL & ETL Sanitation.
- Minimum dimensions of 82 $\frac{3}{4}$ "H x 54 $\frac{1}{4}$ "W x 32"D
- Maximum dimensions of 84 $\frac{3}{4}$ "H x 56 $\frac{1}{4}$ "W x 34"D
- Forty nine cubic feet or larger.

Commercial walk-in freezer:

The Commercial walk-in freezer must meet the following specifications:

- Commercial Indoor Walk-in Freezer with floor.
- Insulation: Minimum 4-inch foamed-in-place urethane (x) Class 1
- Maximum Dimensions of 5'10" x 11'7" x 6'6-1/2"H.
- Minimum Dimensions of 5'9" x 11'6" x 6'5 1/2" H.
- Interior & Exterior 26 Ga. stucco galvanized.
- Interior Floor 18 Ga. Stainless Steel.
- Entrance Door: 34" x 65" with door closer included.
- VXS-CFL compact fluorescent light or similar.
- Weiss 24DT-SP-LT digital therm/switch or equal.
- 115v pressure relief port.
- Non-skid strips every 6"
- Refrigeration:
 - -QHA-0084L4-1SE-02 (8400 btuh) - 10F holding temp @ 95 deg F amb.
 - TPQ 20 ft lines.
 - Air Cooled.
 - R-404A.
 - Outdoor.
 - Weather Cover.
 - Low Amb control.
 - Full hermetic.
 - 0250 low 2-1/2 hp ³
 - Voltage: 208/230-1-60.
 - Condensing Unit: Witt PWA1215L44D-2/PSC motors or equal.
 - Evaporator: Witt SE24-85 w/ECM motors or equal.
 - To be mounted on building roof by successful bidder.
 - Three phase electricity.

Pricing Sheet & Manufacturer's List

Item Number	Quantity	Description	Unit Price	Amount
1	1	Commercial Dishwasher as described above	8002	8002 ⁰⁰
2	1	Commercial two-door refrigerator as described above	3040	3040 ⁰⁰
3	1	Commercial walk-in freezer	13958	13958 ⁰⁰
			Total	25,000 ⁰⁰

Item	Manufacturer
Commercial Dishwasher	CMA
Commercial two-door refrigerator	WOLLAKE
Commercial walk-in freezer	ARCTIC IND.

VENDOR PREFERENCE CERTIFICATE

Certification and application* is hereby made for Preference in accordance with West Virginia Code, §5A-3-37. (Does not apply to construction contracts). West Virginia Code, §5A-3-37, provides an opportunity for qualifying vendors to request (at the time of bid) preference for their residency status. Such preference is an evaluation method only and will be applied only to the cost bid in accordance with the West Virginia Code. This certificate for application is to be used to request such preference. The Purchasing Division will make the determination of the Resident Vendor Preference, if applicable.

1. Application is made for 2.5% resident vendor preference for the reason checked:

- Bidder is an individual resident vendor and has resided continuously in West Virginia for four (4) years immediately preceding the date of this certification; or, Bidder is a partnership, association or corporation resident vendor and has maintained its headquarters or principal place of business continuously in West Virginia for four (4) years immediately preceding the date of this certification; or 80% of the ownership interest of Bidder is held by another individual, partnership, association or corporation resident vendor who has maintained its headquarters or principal place of business continuously in West Virginia for four (4) years immediately preceding the date of this certification; or, Bidder is a nonresident vendor which has an affiliate or subsidiary which employs a minimum of one hundred state residents and which has maintained its headquarters or principal place of business within West Virginia continuously for the four (4) years immediately preceding the date of this certification; or,

2. Application is made for 2.5% resident vendor preference for the reason checked:

Bidder is a resident vendor who certifies that, during the life of the contract, on average at least 75% of the employees working on the project being bid are residents of West Virginia who have resided in the state continuously for the two years immediately preceding submission of this bid; or,

3. Application is made for 2.5% resident vendor preference for the reason checked:

Bidder is a nonresident vendor employing a minimum of one hundred state residents or is a nonresident vendor with an affiliate or subsidiary which maintains its headquarters or principal place of business within West Virginia employing a minimum of one hundred state residents who certifies that, during the life of the contract, on average at least 75% of the employees or Bidder's affiliate's or subsidiary's employees are residents of West Virginia who have resided in the state continuously for the two years immediately preceding submission of this bid; or,

4. Application is made for 5% resident vendor preference for the reason checked:

Bidder meets either the requirement of both subdivisions (1) and (2) or subdivision (1) and (3) as stated above; or,

5. Application is made for 3.5% resident vendor preference who is a veteran for the reason checked:

Bidder is an individual resident vendor who is a veteran of the United States armed forces, the reserves or the National Guard and has resided in West Virginia continuously for the four years immediately preceding the date on which the bid is submitted; or,

6. Application is made for 3.5% resident vendor preference who is a veteran for the reason checked:

Bidder is a resident vendor who is a veteran of the United States armed forces, the reserves or the National Guard, if, for purposes of producing or distributing the commodities or completing the project which is the subject of the vendor's bid and continuously over the entire term of the project, on average at least seventy-five percent of the vendor's employees are residents of West Virginia who have resided in the state continuously for the two immediately preceding years.

Bidder understands if the Secretary of Revenue determines that a Bidder receiving preference has failed to continue to meet the requirements for such preference, the Secretary may order the Director of Purchasing to: (a) reject the bid; or (b) assess a penalty against such Bidder in an amount not to exceed 5% of the bid amount and that such penalty will be paid to the contracting agency or deducted from any unpaid balance on the contract or purchase order.

By submission of this certificate, Bidder agrees to disclose any reasonably requested information to the Purchasing Division and authorizes the Department of Revenue to disclose to the Director of Purchasing appropriate information verifying that Bidder has paid the required business taxes, provided that such information does not contain the amounts of taxes paid nor any other information deemed by the Tax Commissioner to be confidential.

Under penalty of law for false swearing (West Virginia Code, §61-5-3), Bidder hereby certifies that this certificate is true and accurate in all respects; and that if a contract is issued to Bidder and if anything contained within this certificate changes during the term of the contract, Bidder will notify the Purchasing Division in writing immediately.

Bidder: WARDS Inc.

Signed: Gary R. Hill

Date: 4-25-11

Title: Sales Mgr.

*Check any combination of preference consideration(s) indicated above, which you are entitled to receive.

STATE OF WEST VIRGINIA
Purchasing Division

PURCHASING AFFIDAVIT

West Virginia Code §5A-3-10a states: No contract or renewal of any contract may be awarded by the state or any of its political subdivisions to any vendor or prospective vendor when the vendor or prospective vendor or a related party to the vendor or prospective vendor is a debtor and the debt owed is an amount greater than one thousand dollars in the aggregate.

DEFINITIONS:

"Debt" means any assessment, premium, penalty, fine, tax or other amount of money owed to the state or any of its political subdivisions because of a judgment, fine, permit violation, license assessment, defaulted workers' compensation premium, penalty or other assessment presently delinquent or due and required to be paid to the state or any of its political subdivisions, including any interest or additional penalties accrued thereon.

"Debtor" means any individual, corporation, partnership, association, limited liability company or any other form or business association owing a debt to the state or any of its political subdivisions. "Political subdivision" means any county commission; municipality; county board of education; any instrumentality established by a county or municipality; any separate corporation or instrumentality established by one or more counties or municipalities, as permitted by law; or any public body charged by law with the performance of a government function or whose jurisdiction is coextensive with one or more counties or municipalities. "Related party" means a party, whether an individual, corporation, partnership, association, limited liability company or any other form or business association or other entity whatsoever, related to any vendor by blood, marriage, ownership or contract through which the party has a relationship of ownership or other interest with the vendor so that the party will actually or by effect receive or control a portion of the benefit, profit or other consideration from performance of a vendor contract with the party receiving an amount that meets or exceeds five percent of the total contract amount.

EXCEPTION: The prohibition of this section does not apply where a vendor has contested any tax administered pursuant to chapter eleven of this code, workers' compensation premium, permit fee or environmental fee or assessment and the matter has not become final or where the vendor has entered into a payment plan or agreement and the vendor is not in default of any of the provisions of such plan or agreement.

Under penalty of law for false swearing (*West Virginia Code* §61-5-3), it is hereby certified that the vendor affirms and acknowledges the information in this affidavit and is in compliance with the requirements as stated.

WITNESS THE FOLLOWING SIGNATURE

Vendor's Name: WARRS INC.

Authorized Signature: Gary H. Hill Date: 4-25-11

State of West Virginia

County of Harrison, to-wit:

Taken, subscribed, and sworn to before me this 25 day of April, 2011.

My Commission expires 12-20-2016, 20 .

AFFIX SEAL HERE

NOTARY PUBLIC Scott Yates

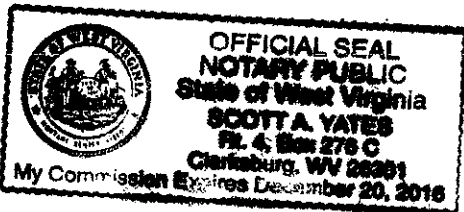

GENERAL TERMS & CONDITIONS REQUEST FOR QUOTATION (RFQ) AND REQUEST FOR PROPOSAL (RFP)

1. Awards will be made in the best interest of the State of West Virginia.
 2. The State may accept or reject in part, or in whole, any bid.
 3. Prior to any award, the apparent successful vendor must be properly registered with the Purchasing Division and have paid the required \$125 fee.
 4. All services performed or goods delivered under State Purchase Order/Contracts are to be continued for the term of the Purchase Order/Contracts, contingent upon funds being appropriated by the Legislature or otherwise being made available. In the event funds are not appropriated or otherwise available for these services or goods this Purchase Order/Contract becomes void and of no effect after June 30.
 5. Payment may only be made after the delivery and acceptance of goods or services.
 6. Interest may be paid for late payment in accordance with the *West Virginia Code*.
 7. Vendor preference will be granted upon written request in accordance with the *West Virginia Code*.
 8. The State of West Virginia is exempt from federal and state taxes and will not pay or reimburse such taxes.
 9. The Director of Purchasing may cancel any Purchase Order/Contract upon 30 days written notice to the seller.
 10. The laws of the State of West Virginia and the *Legislative Rules* of the Purchasing Division shall govern the purchasing process.
 11. Any reference to automatic renewal is hereby deleted. The Contract may be renewed only upon mutual written agreement of the parties.
 12. **BANKRUPTCY:** In the event the vendor/contractor files for bankruptcy protection, the State may deem this contract null and void, and terminate such contract without further order.
 13. **HIPAA BUSINESS ASSOCIATE ADDENDUM:** The West Virginia State Government HIPAA Business Associate Addendum (BAA), approved by the Attorney General, is available online at www.state.wv.us/admin/purchase/vrc/hipaa.htm and is hereby made part of the agreement. Provided that the Agency meets the definition of a Cover Entity (45 CFR §160.103) and will be disclosing Protected Health Information (45 CFR §160.103) to the vendor.
 14. **CONFIDENTIALITY:** The vendor agrees that he or she will not disclose to anyone, directly or indirectly, any such personally identifiable information or other confidential information gained from the agency, unless the individual who is the subject of the information consents to the disclosure in writing or the disclosure is made pursuant to the agency's policies, procedures, and rules. Vendor further agrees to comply with the Confidentiality Policies and Information Security Accountability Requirements, set forth in <http://www.state.wv.us/admin/purchase/privacy/noticeConfidentiality.pdf>.
 15. **LICENSING:** Vendors must be licensed and in good standing in accordance with any and all state and local laws and requirements by any state or local agency of West Virginia, including, but not limited to, the West Virginia Secretary of State's Office, the West Virginia Tax Department, and the West Virginia Insurance Commission. The vendor must provide all necessary releases to obtain information to enable the director or spending unit to verify that the vendor is licensed and in good standing with the above entities.
 16. **ANTITRUST:** In submitting a bid to any agency for the State of West Virginia, the bidder offers and agrees that if the bid is accepted the bidder will convey, sell, assign or transfer to the State of West Virginia all rights, title and interest in and to all causes of action it may now or hereafter acquire under the antitrust laws of the United States and the State of West Virginia for price fixing and/or unreasonable restraints of trade relating to the particular commodities or services purchased or acquired by the State of West Virginia. Such assignment shall be made and become effective at the time the purchasing agency tenders the initial payment to the bidder.
- I certify that this bid is made without prior understanding, agreement, or connection with any corporation, firm, limited liability company, partnership, or person or entity submitting a bid for the same material, supplies, equipment or services and is in all respects fair and without collusion or Fraud. I further certify that I am authorized to sign the certification on behalf of the bidder or this bid.

INSTRUCTIONS TO BIDDERS

1. Use the quotation forms provided by the Purchasing Division. Complete all sections of the quotation form.
2. Items offered must be in compliance with the specifications. Any deviation from the specifications must be clearly indicated by the bidder. Alternates offered by the bidder as **EQUAL** to the specifications must be clearly defined. A bidder offering an alternate should attach complete specifications and literature to the bid. The Purchasing Division may waive minor deviations to specifications.
3. Unit prices shall prevail in case of discrepancy. All quotations are considered F.O.B. destination unless alternate shipping terms are clearly identified in the quotation.
4. All quotations must be delivered by the bidder to the office listed below prior to the date and time of the bid opening. Failure of the bidder to deliver the quotations on time will result in bid disqualifications: Department of Administration, Purchasing Division, 2019 Washington Street East, P.O. Box 50130, Charleston, WV 25305-0130
5. Communication during the solicitation, bid, evaluation or award periods, except through the Purchasing Division, is strictly prohibited (W.Va. C.S.R. §148-1-6.6).

ERIE INSURANCE
PROPERTY & CASUALTY COMPANY
BID BOND

Know All Men by These Presents,

Bond No. EE1052

That we, WARDS INC.
(hereinafter called the Principal) as Principal, and the ERIE INSURANCE PROPERTY & CASUALTY COMPANY, of
Erie, Pennsylvania, a corporation duly organized under the laws of the State of Pennsylvania, (hereinafter
called the Surety), as Surety, are held and firmly bound unto STATE OF WV

.....hereinafter called the Oblige in the full and just sum of ONE THOUSAND
TWO HUNDRED FIFTY — TWO HUNDRED Dollars, (\$ 1,250.00),
good and lawful money of the United States of America, to the payments of which sum of money well
and truly to be made, the said Principal and Surety bind themselves, their and each of their heirs, executors,
administrators, successors and assigns, jointly and severally, firmly by these presents.

Signed, sealed and dated this 25TH day of APRIL, A.D. 2011.

THE CONDITION OF THIS OBLIGATION IS SUCH: That, if the Oblige shall make any award within 30
days to the Principal for INSTALLING NEW KITCHEN EQUIPMENT
TO GO WITH THE KITCHEN REMODEL AT
TRAPT LAKE STATE PARK

according to the terms of the proposal or bid made by the Principal therefor, and the Principal shall
duly make and enter into a contract with the Oblige in accordance with the terms of said proposal
or bid and award and shall give bond for the faithful performance thereof with the Surety or Sureties
approved by the Oblige; or if the Principal shall, in case of failure so to do, pay the Oblige the damages
which the Oblige may suffer by reason of such failure, not exceeding the penalty of this bond, then
this obligation shall be null and void; otherwise it shall be and remain in full force and effect.

In Testimony Whereof, the Principal and Surety have caused these presents to be duly signed and sealed.

Principal. WARDS INC

Witness: [Signature]

By: [Signature]

ERIE INSURANCE
PROPERTY & CASUALTY COMPANY

Witness: Melissa F. Helms

By: [Signature]

Attorney-in-Fact



POWER OF ATTORNEY

KNOW ALL MEN BY THESE PRESENTS: That ERIE INSURANCE COMPANY, a corporation duly organized under the laws of the Commonwealth of Pennsylvania, does hereby make, constitute and appoint _____

----- Daniel W. Webster and Ronald W. Webster -----

individually, its true and lawful Attorney-in-Fact, to make, execute, seal and deliver for and on its behalf, and as its act and deed: any and all bonds and undertakings of suretyship, _____

----- each in a penalty not to exceed the sum of five hundred thousand dollars (\$500,000.00). -----

And to bind ERIE INSURANCE COMPANY thereby as fully and to the same extent as if such bonds and undertakings and other writings obligatory in the nature thereof were signed by the appropriate officer of ERIE INSURANCE COMPANY and sealed and attested by one other of such officers, and hereby ratifies and confirms all that its said Attorney(s)-in-Fact may do in pursuance hereof.

The Power of Attorney is granted under and by authority of the following Resolution adopted by the Board of Directors of ERIE INSURANCE COMPANY on the 11th day of March, 2008, and said Resolution has not been amended or repealed:

“RESOLVED, that the President, or any Senior Vice President or Vice President shall have power and authority to: (a) Appoint Attorney(s)-in-Fact and to authorize them to execute on behalf of the Company, bonds and undertakings, recognizances, contracts of indemnity and other writings obligatory in the nature thereof, and, (b) Remove any such Attorney-in-Fact at any time and revoke the power and authority given to him; and

RESOLVED, that Attorney(s)-in-Fact shall have power and authority, subject to the terms and limitations of the Power of Attorney issued to them, to execute and deliver on behalf of the Company, bonds and undertakings, recognizances, contracts of indemnity and other writings obligatory in the nature thereof. The corporate seal is not necessary for the validity of any bonds and undertakings, recognizances, contracts of indemnity and other writings obligatory in the nature thereof.”

This Power of Attorney is signed and sealed by facsimiles under and by virtue of the following Resolution adopted by the Board of Directors of ERIE INSURANCE COMPANY on the 18th day of September, 2008, at which a quorum was present and said Resolution has not been amended or repealed:

“RESOLVED, that the signature of Terrence W. Cavanaugh, as President and Chief Executive Officer of the Company, and the Seal of the Company may be affixed by the following facsimiles on any Limited Power of Attorney for the execution of bonds, undertakings, recognizances, contracts and other writings in the nature thereof, and the signature of James J. Tanous, as Secretary of the Company, the Seal of the Company, the signature of Sheila M. Hirsch, as Notary Public, and her Notarial Seal, may also be affixed by the following facsimiles to any certificate or acknowledgment of any such Limited Power of Attorney, and only under such circumstances shall said facsimiles be valid and binding on the Company.”

IN WITNESS WHEREOF, ERIE INSURANCE COMPANY has caused these presents to be signed by its President and Chief Executive Officer, and its corporate seal to be hereto affixed this 18th day of September, 2008.

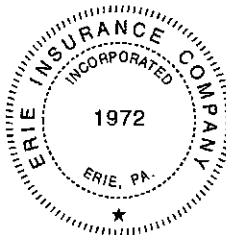

Terrence W. Cavanaugh
Terrence W. Cavanaugh
President and Chief Executive Officer

STATE OF PENNSYLVANIA } ss.
COUNTY OF ERIE

On this 18th day of September, 2008, before me personally came Terrence W. Cavanaugh, to me known, who being by me duly sworn, did depose and say: that he is President and Chief Executive Officer of ERIE INSURANCE COMPANY, the corporation described in and which executed the above instrument; that he knows the Seal of said corporation; that the Seal affixed to the said instrument is such corporate Seal; that it was so affixed by order of the Board of Directors of said corporation and that he signed his name thereto by like order.



Sheila M. Hirsch
My commission expires June 27, 2012
Notary Public

CERTIFICATE

I, James J. Tanous, Secretary of ERIE INSURANCE COMPANY, do hereby certify that the original POWER OF ATTORNEY, of which the foregoing is a full, true and correct copy, is still in full force and effect as of the date below.

In witness whereof, I have hereunto subscribed my name and affixed corporate Seal of the Company by facsimiles pursuant to the action of the Board of Directors of the Company,

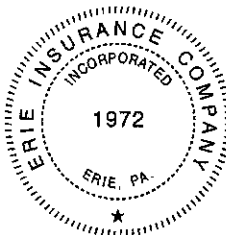

James J. Tanous
James J. Tanous, Secretary

this 25th day of April 2011



State of West Virginia
 Department of Administration
 Purchasing Division
 2019 Washington Street East
 Post Office Box 50130
 Charleston, WV 25305-0130

Request for Quotation

RFQ NUMBER
DNRB11155

PAGE
1

ADDRESS CORRESPONDENCE TO ATTENTION OF
FRANK WHITTAKER
304-558-2316

RFQ COPY
 TYPE NAME/ADDRESS HERE

WARDS Inc.
PO Box 179
Anmoore, WV 26323

SHIP TO

DIVISION OF NATURAL RESOURCES
 TYGART LAKE STATE PARK
 ATTN: PARK SUPERINTENDENT
 ROUTE 1, BOX 260
 GRAFTON, WV
 26354 265-3383

DATE PRINTED	TERMS OF SALE	SHIP VIA	FOB	FREIGHT TERMS
03/23/2011				

BID OPENING DATE: **04/26/2011** BID OPENING TIME **01:30PM**

LINE	QUANTITY	UOP	CAT NO	ITEM NUMBER	UNIT PRICE	AMOUNT
0001	1	LS		740-70	* 25,000.00	25,000.00
<p>COMMERCIAL RESTAURANT EQUIPMENT</p> <p>THE WEST VIRGINIA PURCHASING DIVISION, FOR THE AGENCY, THE WEST VIRGINIA DIVISION OF NATURAL RESOURCES IS SOLICITING BIDS FOR COMMERCIAL RESTAURANT EQUIPMENT FOR TYGART LAKE STATE PARK PER THE ATTACHED SPECIFICATIONS.</p> <p>ALL TECHNICAL QUESTIONS MUST BE SUBMITTED IN WRITING TO FRANK WHITTAKER IN THE WV PURCHASING DIVISION VIA EMAIL AT FRANK.M.WHITTAKER@WV.GOV OR VIA FAX AT 304-558-4115. DEADLINE FOR ALL TECHNICAL QUESTIONS IS 04/07/2011. ALL TECHNICAL QUESTIONS WILL BE ADDRESSED BY ADDENDUM AFTER THE DEADLINE.</p> <p>ALL BIDDERS ARE ENCOURAGED TO VISIT THE SITE.</p> <p>EXHIBIT 5</p> <p>WEST VIRGINIA CODE 21-1D-5 PROVIDES THAT: ANY SOLICITATION FOR A PUBLIC IMPROVEMENT CONSTRUCTION CONTRACT REQUIRES EACH VENDOR THAT SUBMITS A BID FOR THE WORK TO SUBMIT AT THE SAME TIME AN AFFIDAVIT OF COMPLIANCE WITH THE BID. THE ENCLOSED DRUG-FREE WORKPLACE AFFIDAVIT MUST BE SIGNED AND SUBMITTED WITH THE BID AS EVIDENCE OF THE VENDOR'S COMPLIANCE WITH THE PROVISIONS OF ARTICLE 1D, CHAPTER 21 OF THE WEST VIRGINIA CODE. FAILURE TO SUBMIT THE SIGNED DRUG-FREE WORKPLACE AFFIDAVIT WITH THE BID SHALL RESULT IN DISQUALIFICATION OF SUCH BID.</p>						

SEE REVERSE SIDE FOR TERMS AND CONDITIONS

SIGNATURE <i>Gay R. Hill</i>	TELEPHONE 304-623-4646	DATE 4-25-11
TITLE <i>Sales Mgr</i>	FEBN 550579928	ADDRESS CHANGES TO BE NOTED ABOVE

WHEN RESPONDING TO RFQ, INSERT NAME AND ADDRESS IN SPACE ABOVE LABELED 'VENDOR'



State of West Virginia
 Department of Administration
 Purchasing Division
 2019 Washington Street East
 Post Office Box 50130
 Charleston, WV 25305-0130

Request for Quotation

RFQ NUMBER
DNRB11155

PAGE
2

ADDRESS CORRESPONDENCE TO ATTENTION OF
FRANK WHITTAKER 304-558-2316

VENDOR

RFQ COPY
 TYPE NAME/ADDRESS HERE

WARPS Inc
P.O. BOX 179
An Moore, WV 26323

SHIP TO

DIVISION OF NATURAL RESOURCES
 TYGART LAKE STATE PARK
 ATTN: PARK SUPERINTENDENT
 ROUTE 1, BOX 260
 GRAFTON, WV 26354 265-3383

DATE PRINTED	TERMS OF SALE	SHIP VIA	F.O.B.	FREIGHT TERMS
03/23/2011				

BID OPENING DATE: **04/26/2011** BID OPENING TIME **01:30PM**

LINE	QUANTITY	UOP	CAT NO	ITEM NUMBER	UNIT PRICE	AMOUNT
<p>NOTICE TO PROCEED: THIS CONTRACT IS TO BE PERFORMED WITHIN 30 CALENDAR DAYS AFTER THE NOTICE TO PROCEED IS RECEIVED. UNLESS OTHERWISE SPECIFIED, THE FULLY EXECUTED PURCHASE ORDER WILL BE CONSIDERED NOTICE TO PROCEED.</p> <p>CANCELLATION: THE DIRECTOR OF PURCHASING RESERVES THE RIGHT TO CANCEL THIS CONTRACT IMMEDIATELY UPON WRITTEN NOTICE TO THE VENDOR IF THE MATERIALS OR WORKMANSHIP SUPPLIED ARE OF AN INFERIOR QUALITY OR DO NOT CONFORM WITH THE SPECIFICATIONS OF THE BID AND CONTRACT HERE IN.</p> <p>WAGE RATES: THE CONTRACTOR OR SUBCONTRACTOR SHALL PAY THE HIGHER OF THE U.S. DEPARTMENT OF LABOR MINIMUM WAGE RATES AS ESTABLISHED FOR TAYLOR COUNTY, PURSUANT TO WEST VIRGINIA CODE 21-5A, ET, SEQ. (PREVAILING WAGE RATES APPLY TO THIS PROJECT)</p> <p>ARBITRATION: ANY REFERENCES MADE TO ARBITRATION OR INTEREST FOR PAYMENTS DUE (EXCEPT FOR ANY INTEREST REQUIRED BY STATE LAW) CONTAINED IN THIS CONTRACT OR IN ANY AMERICAN INSTITUTE OF ARCHITECTS DOCUMENTS PERTAINING TO THIS CONTRACT ARE HEREBY DELETED.</p> <p>WORKERS' COMPENSATION: VENDOR IS REQUIRED TO PROVIDE A CERTIFICATE FROM WORKERS' COMPENSATION IF SUCCESSFUL.</p> <p>ALL OF THE ITEMS CHECKED BELOW WILL BE A REQUIREMENT OF THIS CONTRACT:</p> <p>(XX) INSURANCE: SUCCESSFUL VENDOR SHALL FURNISH PROOF OF COMMERCIAL GENERAL LIABILITY INSURANCE PRIOR TO ISSUANCE OF CONTRACT. UNLESS OTHERWISE SPECIFIED IN THE BID DOCUMENTS, THE MINIMUM AMOUNT OF INSURANCE</p>						

SEE REVERSE SIDE FOR TERMS AND CONDITIONS			
SIGNATURE	TELEPHONE	DATE	
<i>Frank R. Hitt</i>	304-623-6646	4-25-11	
TITLE	FAX	ADDRESS CHANGES TO BE NOTED ABOVE	
<i>Sales Manager</i>	550579928		

WHEN RESPONDING TO RFQ, INSERT NAME AND ADDRESS IN SPACE ABOVE LABELED 'VENDOR'



State of West Virginia
 Department of Administration
 Purchasing Division
 2019 Washington Street East
 Post Office Box 50130
 Charleston, WV 25305-0130

**Request for
 Quotation**

RFQ NUMBER
DNRB11155

PAGE
3

ADDRESS CORRESPONDENCE TO ATTENTION OF
**FRANK WHITTAKER
 304-558-2316**

RFQ COPY
 TYPE NAME/ADDRESS HERE

POST OFFICE

*WARDS FWC
 P.O. Box 179
 ANMOORE, WV 26323*

SHIP TO

DIVISION OF NATURAL RESOURCES
 TYGART LAKE STATE PARK
 ATTN: PARK SUPERINTENDENT
 ROUTE 1, BOX 260
 GRAFTON, WV
 26354 265-3383

DATE PRINTED 03/23/2011	TERMS OF SALE	SHIP VIA	FOB	FREIGHT TERMS
-----------------------------------	---------------	----------	-----	---------------

BID OPENING DATE: **04/26/2011** BID OPENING TIME **01:30PM**

LINE	QUANTITY	UOP	CAT NO	ITEM NUMBER	UNIT PRICE	AMOUNT
<p>COVERAGE REQUIRED IS \$250,000.</p> <p>() BUILDERS RISK INSURANCE: SUCCESSFUL VENDOR SHALL FURNISH PROOF OF BUILDERS RISK - ALL RISK INSURANCE IN AN AMOUNT EQUAL TO 100% OF THE AMOUNT OF THE CONTRACT.</p> <p>(XX) BONDS: FIVE PERCENT (5%) OF THE TOTAL AMOUNT OF THE BID PAYABLE TO THE STATE OF WEST VIRGINIA, SHALL BE SUBMITTED WITH EACH BID AS A BID BOND. THE SUCCESSFUL BIDDER SHALL ALSO FURNISH A PERFORMANCE BOND AND LABOR/MATERIAL BOND FOR 100% OF THE AMOUNT OF THE CONTRACT. BONDS MAY BE PROVIDED IN THE FORM OF A CERTIFIED CHECK IRREVOCABLE LETTER OF CREDIT, OR BOND FURNISHED BY A SOLVENT SURETY COMPANY AUTHORIZED TO DO BUSINESS IN THE STATE OF WEST VIRGINIA. A LETTER OF CREDIT SUBMITTED IN LIEU OF A BOND WILL ONLY BE ALLOWED FOR PROJECTS UNDER \$100,000. PERSONAL OR BUSINESS CHECKS ARE NOT ACCEPTABLE IN LIEU OF THE 5% BID BOND, PERFORMANCE BOND, OR LABOR AND MATERIAL BOND.</p> <p>() MAINTENANCE BOND: A TWO (2) YEAR MAINTENANCE BOND COVERING THE ROOFING SYSTEM WILL BE A REQUIREMENT OF THE SUCCESSFUL VENDOR.</p> <p>REV. 11/00</p> <p>EXHIBIT 7</p> <p>DOMESTIC ALUMINUM, GLASS & STEEL IN PUBLIC WORKS PROJECTS</p> <p>IN ACCORDANCE WITH WEST VIRGINIA CODE 5-19-1 ET., SEQ., EVERY CONTRACT FOR CONSTRUCTION, RECONSTRUCTION, ALTERATION, REPAIR, IMPROVEMENT OR MAINTENANCE OF PUBLIC WORKS, WHERE THE COST IS MORE THAN \$50,000 AND,</p>						

SEE REVERSE SIDE FOR TERMS AND CONDITIONS			
SIGNATURE <i>Frank Whittaker</i>	TELEPHONE 304-673-6646	DATE 4-25-11	
TITLE <i>Sales Mgr</i>	FEIN 550579928	ADDRESS CHANGES TO BE NOTED ABOVE	

WHEN RESPONDING TO RFQ, INSERT NAME AND ADDRESS IN SPACE ABOVE LABELED 'VENDOR'



State of West Virginia
 Department of Administration
 Purchasing Division
 2019 Washington Street East
 Post Office Box 50130
 Charleston, WV 25305-0130

Request for Quotation

RFO NUMBER
DNRB11155

PAGE
4

ADDRESS CORRESPONDENCE TO ATTENTION OF
FRANK WHITTAKER
304-558-2316

RFQ COPY
 TYPE NAME/ADDRESS HERE

MATERIAL

SHIP TO

DIVISION OF NATURAL RESOURCES
 TYGART LAKE STATE PARK
 ATTN: PARK SUPERINTENDENT
 ROUTE 1, BOX 260
 GRAFTON, WV
 26354 265-3383

DATE PRINTED	TERMS OF SALE	SHIP VIA	F.O.B.	FREIGHT TERMS
03/23/2011				
BID OPENING DATE: 04/26/2011		BID OPENING TIME 01:30PM		

LINE	QUANTITY	UOP	CAT NO	ITEM NUMBER	UNIT PRICE	AMOUNT
<p>IN THE CASE OF STEEL ONLY, WHERE THE COST OF STEEL IS MORE THAN \$50,000 OR WHERE MORE THAN 10,000 POUNDS OF STEEL ARE REQUIRED, THE STATE WILL ACCEPT ONLY ALUMINUM GLASS, OR STEEL PRODUCTS PRODUCED IN THE UNITED STATES. IN ADDITION, ITEMS OF MACHINERY OR EQUIPMENT PURCHASED FOR USE AT THE SITE OF PUBLIC WORKS SHALL BE MADE OF DOMESTIC ALUMINUM, GLASS OR STEEL, UNLESS THE COST OF THE PRODUCT IS LESS THAN \$50,000 OR LESS THAN 10,000 POUNDS OF STEEL ARE USED IN PUBLIC WORKS PROJECTS.</p> <p>FOREIGN MADE ALUMINUM, GLASS OR STEEL PRODUCTS MAY BE ACCEPTED ONLY IF THE COST OF DOMESTIC PRODUCTS IS FOUND TO BE UNREASONABLE. SUCH COST IS UNREASONABLE IF IT IS 20% OR MORE HIGHER THAN THE BID PRICE FOR FOREIGN MADE PRODUCTS. IF THE DOMESTIC ALUMINUM, GLASS OR STEEL PRODUCTS TO BE SUPPLIED OR PRODUCED IN A "SUBSTANTIAL LABOR SURPLUS AREA", AS DEFINED BY THE UNITED STATES DEPARTMENT OF LABOR, FOREIGN PRODUCTS MAY BE SUPPLIED ONLY IF DOMESTIC PRODUCTS ARE 30% OR MORE HIGHER IN PRICE THAN THE FOREIGN MADE PRODUCTS.</p> <p>IF, PRIOR TO THE AWARD OF A CONTRACT UNDER THE ABOVE PROVISIONS, THE SPENDING OFFICER OF THE SPENDING UNIT DETERMINES THAT THERE EXISTS A BID FOR LIKE FOREIGN ALUMINUM, GLASS OR STEEL THAT IS REASONABLE AND LOWER THAN THE LOWEST BID DOMESTIC PRODUCTS, THE SPENDING OFFICE MAY REQUEST, IN WRITING, A REEVALUATION AND REDUCTION IN THE LOWEST BID FOR SUCH DOMESTIC PRODUCTS. ALL VENDORS MUST INDICATE IN THEIR BID IF THEY ARE SUPPLYING FOREIGN ALUMINUM, GLASS OR STEEL.</p> <p>REV. 3/88</p> <p>EXHIBIT 9</p>						

SEE REVERSE SIDE FOR TERMS AND CONDITIONS

SIGNATURE <i>Frank Whittaker</i>	TELEPHONE 304-623-6696	DATE 4-25-11
TITLE Sales Mgr	FEIN 550579928	ADDRESS CHANGES TO BE NOTED ABOVE

WHEN RESPONDING TO RFQ, INSERT NAME AND ADDRESS IN SPACE ABOVE LABELED 'VENDOR'



State of West Virginia
 Department of Administration
 Purchasing Division
 2019 Washington Street East
 Post Office Box 50130
 Charleston, WV 25305-0130

Request for Quotation

RFQ NUMBER
DNRB11155

PAGE
5

ADDRESS CORRESPONDENCE TO ATTENTION OF
**FRANK WHITTAKER
 304-558-2316**

RFQ COPY
 TYPE NAME/ADDRESS HERE

PROCUREMENT

SHIP TO

DIVISION OF NATURAL RESOURCES
 TYGART LAKE STATE PARK
 ATTN: PARK SUPERINTENDENT
 ROUTE 1, BOX 260
 GRAFTON, WV
 26354 265-3383

DATE PRINTED	TERMS OF SALE	SHIP VIA	F.O.B.	FREIGHT TERMS
03/23/2011				

BID OPENING DATE: **04/26/2011** BID OPENING TIME **01:30PM**

LINE	QUANTITY	UOP	CAT NO	ITEM NUMBER	UNIT PRICE	AMOUNT
<p>NOTICE FOR ISSUANCE & ACKNOWLEDGEMENT OF CONSTRUCTION PROJECT ADDENDA</p> <p>THE ARCHITECT/ENGINEER AND/OR AGENCY SHALL BE REQUIRED TO ABIDE BY THE FOLLOWING SCHEDULE IN ISSUING CONSTRUCTION PROJECT ADDENDA FOR STATE AGENCIES:</p> <p>(1) THE ARCHITECT/ENGINEER SHALL PREPARE THE ADDENDUM AND A LIST OF ALL PARTIES THAT HAVE PROCURED DRAWINGS AND SPECIFICATIONS FOR THE PROJECT. THE ADDENDUM AND LIST SHALL BE FORWARDED TO THE BUYER IN THE STATE PURCHASING DIVISION. THE ARCHITECT/ENGINEER SHALL ALSO SEND A COPY OF THE ADDENDUM TO THE STATE AGENCY FOR WHICH THE CONTRACT IS ISSUED.</p> <p>(2) THE BUYER SHALL SEND THE ADDENDUM TO ALL INTERESTED PARTIES AND, IF NECESSARY, EXTEND THE BID OPENING DATE. ANY ADDENDUM SHOULD BE RECEIVED BY THE BUYER WITHIN FOURTEEN (14) DAYS PRIOR TO THE BID OPENING DATE.</p> <p>(3) ALL ADDENDA SHOULD BE FORMALLY ACKNOWLEDGED BY ALL BIDDERS AND SUBMITTED TO THE STATE PURCHASING DIVISION. THE SAME RULES AND REGULATIONS THAT APPLY TO THE ORIGINAL BIDDING DOCUMENT SHALL ALSO APPLY TO AN ADDENDUM DOCUMENT. THE ONLY EXCEPTION MAY BE FOR AN ADDENDUM THAT IS ISSUED FOR THE SOLE PURPOSE OF CHANGING A BID OPENING TIME AND/OR DATE.</p> <p>REV. 11/96</p> <p>EXHIBIT 10</p> <p>ADDENDUM ACKNOWLEDGEMENT</p>						

SEE REVERSE SIDE FOR TERMS AND CONDITIONS

SIGNATURE <i>Frank Whittaker</i>	TELEPHONE 304-623-6646	DATE 4-25-11
TITLE Sales Manager	FEIN 550579928	ADDRESS CHANGES TO BE NOTED ABOVE

WHEN RESPONDING TO RFQ, INSERT NAME AND ADDRESS IN SPACE ABOVE LABELED 'VENDOR'



State of West Virginia
 Department of Administration
 Purchasing Division
 2019 Washington Street East
 Post Office Box 50130
 Charleston, WV 25305-0130

Request for Quotation

RFQ NUMBER
DNRB11155

PAGE
6

ADDRESS CORRESPONDENCE TO ATTENTION OF:
FRANK WHITTAKER
304-558-2316

RFQ COPY
 TYPE NAME/ADDRESS HERE

VENDOR

SHIP TO

DIVISION OF NATURAL RESOURCES
 TYGART LAKE STATE PARK
 ATTN: PARK SUPERINTENDENT
 ROUTE 1, BOX 260
 GRAFTON, WV
 26354 265-3383

DATE PRINTED	TERMS OF SALE	SHIP VIA	FOB	FREIGHT TERMS
03/23/2011				

BID OPENING DATE: **04/26/2011** BID OPENING TIME: **01:30PM**

LINE	QUANTITY	UOP	CAT NO	ITEM NUMBER	UNIT PRICE	AMOUNT
<p>I HEREBY ACKNOWLEDGE RECEIPT OF THE FOLLOWING CHECKED ADDENDUM(S) AND HAVE MADE THE NECESSARY REVISIONS TO MY PROPOSAL, PLANS AND/OR SPECIFICATION, ETC.</p> <p>ADDENDUM NOS.:</p> <p>NO. 1 ✓</p> <p>NO. 2 </p> <p>NO. 3 </p> <p>NO. 4 </p> <p>NO. 5 </p> <p>I UNDERSTAND THAT FAILURE TO CONFIRM THE RECEIPT OF TH ADDENDUM(S) MAY BE CAUSE FOR REJECTION OF THE BIDS..</p> <p>VENDOR MUST CLEARLY UNDERSTAND THAT ANY VERBAL REPRESENTATION MADE OR ASSUMED TO BE MADE DURING ANY ORAL DISCUSSION HELD BETWEEN VENDOR'S REPRESENTATIVES AND ANY STATE PERSONNEL IS NOT BINDING. ONLY THE INFORMATION ISSUED IN WRITING AND ADDED TO THE SPECIFICATIONS BY AN OFFICIAL ADDENDUM IS BINDING.</p> <p>..... SIGNATURE</p> <p>..... COMPANY</p> <p>..... DATE</p> <p>REV. 11/96</p>						

SEE REVERSE SIDE FOR TERMS AND CONDITIONS		
SIGNATURE <i>Frank Whittaker</i>	TELEPHONE 304-623-6646	DATE 4-25-11
TITLE SALES MGR	FEIN 5505 9928	ADDRESS CHANGES TO BE NOTED ABOVE

WHEN RESPONDING TO RFQ, INSERT NAME AND ADDRESS IN SPACE ABOVE LABELED 'VENDOR'



State of West Virginia
 Department of Administration
 Purchasing Division
 2019 Washington Street East
 Post Office Box 50130
 Charleston, WV 25305-0130

Request for Quotation

RFQ NUMBER
DNRB11155

PAGE
7

ADDRESS CORRESPONDENCE TO ATTENTION OF
**FRANK WHITTAKER
 304-558-2316**

RFQ COPY
 TYPE NAME/ADDRESS HERE

DIVISION OF NATURAL RESOURCES
 TYGART LAKE STATE PARK
 ATTN: PARK SUPERINTENDENT
 ROUTE 1, BOX 260
 GRAFTON, WV
 26354 265-3383

DATE PRINTED 03/23/2011	TERMS OF SALE	SHIP VIA	F.O.B.	FREIGHT TERMS
BID OPENING DATE: 04/26/2011		BID OPENING TIME 01:30PM		

LINE	QUANTITY	UOP	CAT NO	ITEM NUMBER	UNIT PRICE	AMOUNT
CONTRACTORS LICENSE						
<p>WEST VIRGINIA STATE CODE 21-11-2 REQUIRES THAT ALL PERSONS DESIRING TO PERFORM CONTRACTING WORK IN THIS STATE MUST BE LICENSED. THE WEST VIRGINIA CONTRACTORS LICENSING BOARD IS EMPOWERED TO ISSUE THE CONTRACTORS LICENSE. APPLICATIONS FOR A CONTRACTORS LICENSE MAY BE MADE BY CONTACTING THE WEST VIRGINIA DIVISION OF LABOR CAPITOL COMPLEX, BUILDING 3, ROOM 319, CHARLESTON, WV 25305. TELEPHONE: (304) 558-7890.</p> <p>WEST VIRGINIA STATE CODE 21-11-11 REQUIRES ANY PROSPECTIVE BIDDER TO INCLUDE THE CONTRACTORS LICENSE NUMBER ON THEIR BID.</p> <p>BIDDER TO COMPLETE:</p> <p>CONTRACTORS NAME: <i>WARDS, Inc.</i></p> <p>CONTRACTORS LICENSE NO.: <i>WV 009304</i></p> <p>THE SUCCESSFUL BIDDER WILL BE REQUIRED TO FURNISH A COPY OF THEIR CONTRACTORS LICENSE PRIOR TO ISSUANCE OF A PURCHASE ORDER/CONTRACT</p> <p style="text-align: center;">APPLICABLE LAW</p> <p>THE WEST VIRGINIA STATE CODE, PURCHASING DIVISION RULES AND REGULATIONS, AND THE INFORMATION PROVIDED IN THE "REQUEST FOR QUOTATION" ISSUED BY THE PURCHASING DIVISION IS THE SOLE AUTHORITY GOVERNING THIS PROCUREMENT.</p> <p>ANY INFORMATION PROVIDED IN SPECIFICATION MANUALS, OR ANY OTHER SOURCE, VERBAL OR WRITTEN, WHICH CONTRADICTS</p>						

SEE REVERSE SIDE FOR TERMS AND CONDITIONS

SIGNATURE <i>Frank Whittaker</i>	TELEPHONE <i>304-623-6646</i>	DATE <i>4-25-11</i>
TITLE <i>Sales Mgr</i>	FEIN <i>550579928</i>	ADDRESS CHANGES TO BE NOTED ABOVE

WHEN RESPONDING TO RFQ, INSERT NAME AND ADDRESS IN SPACE ABOVE LABELED 'VENDOR'



State of West Virginia
 Department of Administration
 Purchasing Division
 2019 Washington Street East
 Post Office Box 50130
 Charleston, WV 25305-0130

Request for Quotation

RFQ NUMBER
DNRB11155

PAGE
1

ADDRESS CORRESPONDENCE TO ATTENTION OF
FRANK WHITTAKER
304-558-2316

RFQ COPY

TYPE NAME/ADDRESS HERE

VENDOR

SHIP TO

DIVISION OF NATURAL RESOURCES
 TYGART LAKE STATE PARK
 ATTN: PARK SUPERINTENDENT
 ROUTE 1, BOX 260
 GRAFTON, WV
 26354 265-3383

DATE PRINTED	TERMS OF SALE	SHIP VIA	F.O.B.	FREIGHT TERMS
04/21/2011				

BID OPENING DATE: **05/03/2011** BID OPENING TIME **01:30PM**

LINE	QUANTITY	UOP	CAT NO	ITEM NUMBER	UNIT PRICE	AMOUNT
***** ADDENDUM NO. 1 *****						
THIS ADDENDUM IS ISSUED TO PROVIDE THE ATTACHED TECHNICAL QUESTIONS & ANSWERS AND TO EXTEND THE BID OPENING DATE AND TIME.						
THE BID OPEINING IS EXTENDED TO: 05/03/2011 AT 1:30 PM.						
***** END ADDENDUM NO. 1 *****						
0001	1	LS		740-70		
COMMERCIAL RESTAURANT EQUIPMENT						
***** THIS IS THE END OF RFQ DNRB11155 ***** TOTAL:						# <u>25,000</u>

SEE REVERSE SIDE FOR TERMS AND CONDITIONS

SIGNATURE <i>Frank Whittaker</i>	TELEPHONE 304-623-6646	DATE 4-28-11
TITLE SPLS MGR	FEIN 550579428	ADDRESS CHANGES TO BE NOTED ABOVE

WHEN RESPONDING TO RFQ, INSERT NAME AND ADDRESS IN SPACE ABOVE LABELED 'VENDOR'

**GENERAL TERMS & CONDITIONS
REQUEST FOR QUOTATION (RFQ) AND REQUEST FOR PROPOSAL (RFP)**

1. Awards will be made in the best interest of the State of West Virginia.
2. The State may accept or reject in part, or in whole, any bid.
3. Prior to any award, the apparent successful vendor must be properly registered with the Purchasing Division and have paid the required \$125 fee.
4. All services performed or goods delivered under State Purchase Order/Contracts are to be continued for the term of the Purchase Order/Contracts, contingent upon funds being appropriated by the Legislature or otherwise being made available. In the event funds are not appropriated or otherwise available for these services or goods this Purchase Order/Contract becomes void and of no effect after June 30.
5. Payment may only be made after the delivery and acceptance of goods or services.
6. Interest may be paid for late payment in accordance with the *West Virginia Code*.
7. Vendor preference will be granted upon written request in accordance with the *West Virginia Code*.
8. The State of West Virginia is exempt from federal and state taxes and will not pay or reimburse such taxes.
9. The Director of Purchasing may cancel any Purchase Order/Contract upon 30 days written notice to the seller.
10. The laws of the State of West Virginia and the *Legislative Rules* of the Purchasing Division shall govern the purchasing process.
11. Any reference to automatic renewal is hereby deleted. The Contract may be renewed only upon mutual written agreement of the parties.
12. **BANKRUPTCY:** In the event the vendor/contractor files for bankruptcy protection, the State may deem this contract null and void, and terminate such contract without further order.
13. **HIPAA BUSINESS ASSOCIATE ADDENDUM:** The West Virginia State Government HIPAA Business Associate Addendum (BAA), approved by the Attorney General, is available online at www.state.wv.us/admin/purchase/vrc/hipaa.htm and is hereby made part of the agreement. Provided that the Agency meets the definition of a Cover Entity (45 CFR §160.103) and will be disclosing Protected Health Information (45 CFR §160.103) to the vendor.
14. **CONFIDENTIALITY:** The vendor agrees that he or she will not disclose to anyone, directly or indirectly, any such personally identifiable information or other confidential information gained from the agency, unless the individual who is the subject of the information consents to the disclosure in writing or the disclosure is made pursuant to the agency's policies, procedures, and rules. Vendor further agrees to comply with the Confidentiality Policies and Information Security Accountability Requirements, set forth in <http://www.state.wv.us/admin/purchase/privacy/noticeConfidentiality.pdf>.
15. **LICENSING:** Vendors must be licensed and in good standing in accordance with any and all state and local laws and requirements by any state or local agency of West Virginia, including, but not limited to, the West Virginia Secretary of State's Office, the West Virginia Tax Department, and the West Virginia Insurance Commission. The vendor must provide all necessary releases to obtain information to enable the director or spending unit to verify that the vendor is licensed and in good standing with the above entities.
16. **ANTITRUST:** In submitting a bid to any agency for the State of West Virginia, the bidder offers and agrees that if the bid is accepted the bidder will convey, sell, assign or transfer to the State of West Virginia all rights, title and interest in and to all causes of action it may now or hereafter acquire under the antitrust laws of the United States and the State of West Virginia for price fixing and/or unreasonable restraints of trade relating to the particular commodities or services purchased or acquired by the State of West Virginia. Such assignment shall be made and become effective at the time the purchasing agency tenders the initial payment to the bidder.

I certify that this bid is made without prior understanding, agreement, or connection with any corporation, firm, limited liability company, partnership, or person or entity submitting a bid for the same material, supplies, equipment or services and is in all respects fair and without collusion or fraud. I further certify that I am authorized to sign the certification on behalf of the bidder or this bid.

INSTRUCTIONS TO BIDDERS

1. Use the quotation forms provided by the Purchasing Division. Complete all sections of the quotation form.
2. Items offered must be in compliance with the specifications. Any deviation from the specifications must be clearly indicated by the bidder. Alternates offered by the bidder as **EQUAL** to the specifications must be clearly defined. A bidder offering an alternate should attach complete specifications and literature to the bid. The Purchasing Division may waive minor deviations to specifications.
3. Unit prices shall prevail in case of discrepancy. All quotations are considered F.O.B. destination unless alternate shipping terms are clearly identified in the quotation.
4. All quotations must be delivered by the bidder to the office listed below prior to the date and time of the bid opening. Failure of the bidder to deliver the quotations on time will result in bid disqualifications: Department of Administration, Purchasing Division, 2019 Washington Street East, P.O. Box 50130, Charleston, WV 25305-0130
5. Communication during the solicitation, bid, evaluation or award periods, except through the Purchasing Division, is strictly prohibited (W.Va. C.S.R. §148-1-6.6).

DNRB11155
Addendum #1

To answer technical questions

Question 1. On the job for Tygart Lake State Park bid number #DNRB11155, Which voltage is to be used for the walk-in freezer: 208/230 single phase or 208/230 3-phase? There are two (2) voltages shown on the spec. sheet. Thanks.

Answer 1. 208/230 3-phase is to be used for the walk-in freezer.

Question 2. On the job for Tygart Lake State Park bid number #DNRB11155, on the 2-door refrigerator unit that you're requesting, can it be stainless steel on the outside and plastic on the inside? Versus stainless steel outside and inside?

Answer 2. This commercial two-door refrigerator shall have a stainless steel exterior and stainless steel interior.

Question 3. How tall is the building where the compressors will be installed?

Answer 3. Approximately nine feet, ten inches.

Question 4. What is the actual height dimension of the ceiling in the room where the walk-in will be installed?

Answer 4. The ceiling is a pitched ceiling. The low side is approximately eight feet. The peak is approximately nine feet, ten inches.

Question 5. Please note that with the height dimensions listed on the walk-in, the actual height inside the unit will only be 5' 10". Please ensure that this will be sufficient for your staff and storage requirements.

Answer 5. Yes, this will be sufficient.

Also, please note that all wiring from the breaker box to the dishwasher must meet existing West Virginia building and wiring code. Should the product require an upgrade, it will be the vendor's responsibility to provide said upgrade at no additional cost to the State.



CMA-180
High Temperature
Single Rack
Dishwasher

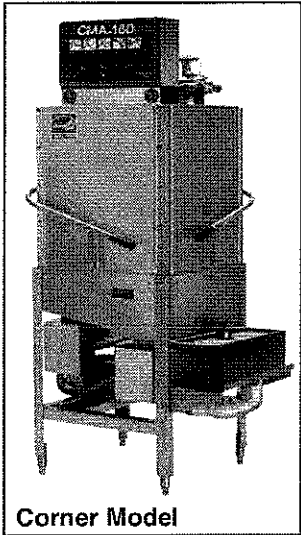

Corner Model

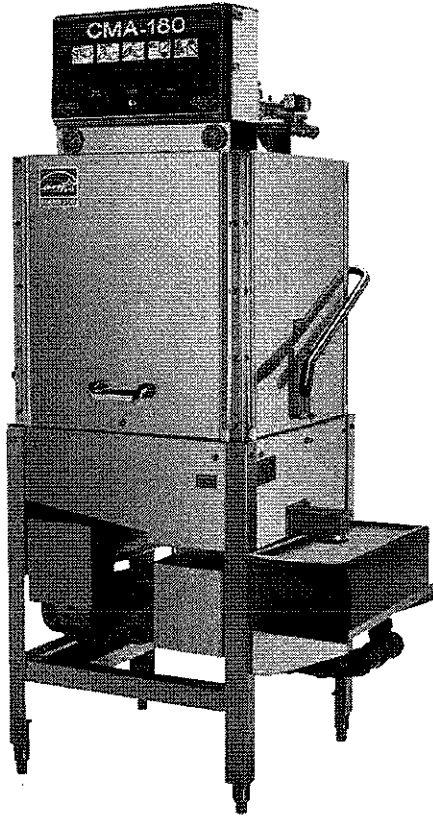

FEATURES:

- **Energy Star Qualified.**
- 60 racks / 240 covers per hour.
- Economical to operate. Uses only .96 gallons of water per cycle.
- Automatic soil purging system. Filters wash water and traps plate debris into an external tray. Tray can be easily removed for dumping contents.
- All stainless steel construction offers durable performance and years of trouble free operation.
- Built-in chemical resistant industrial 5kW heater and optional 12kW booster heater are proven to be more durable than commercial style heaters.
- Unique spray arm system features upper and lower stainless steel wash arms with reinforced end caps. Specially designed pull-pins allow wash arms to be easily removed for cleaning.
- Top mounted control box is water tight and includes a rack counter, extended wash/delimer switch and easy to read temperature gauges.
- Auto start/stop makes operation safe and easy.
- Field convertible for a wide range of applications.
- Safety Temp feature assures 180°F sanitizing rinse every cycle.
- Built-in booster heater configured for both 40°F and 70°F temperature rise.
- Single point electrical connection.
- Field convertible to single or three phase, corner or straight through operation.
- Automatic tank fill.
- Interchangeable upper and lower arms.

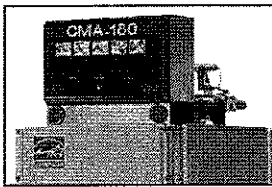

Top mounted control box is water tight and includes a rack counter, extended wash/delimer switch and easy to read temperature gauges.

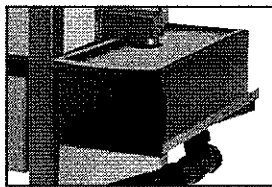

External scrap tray maintains clean wash water and prevents debris from clogging the drain.



Industrial wash tank and optional booster heaters are designed for years of trouble free service.

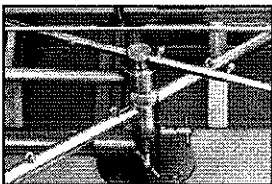

Unique pull-pin design allows wash arms to be easily removed for cleaning.





CMA-180
High Temperature
Single Rack
Dishwasher

WARNING: Plumbing connections must be made by a qualified service company who will comply with all available Federal, State, and Local Health, Plumbing and Safety codes.

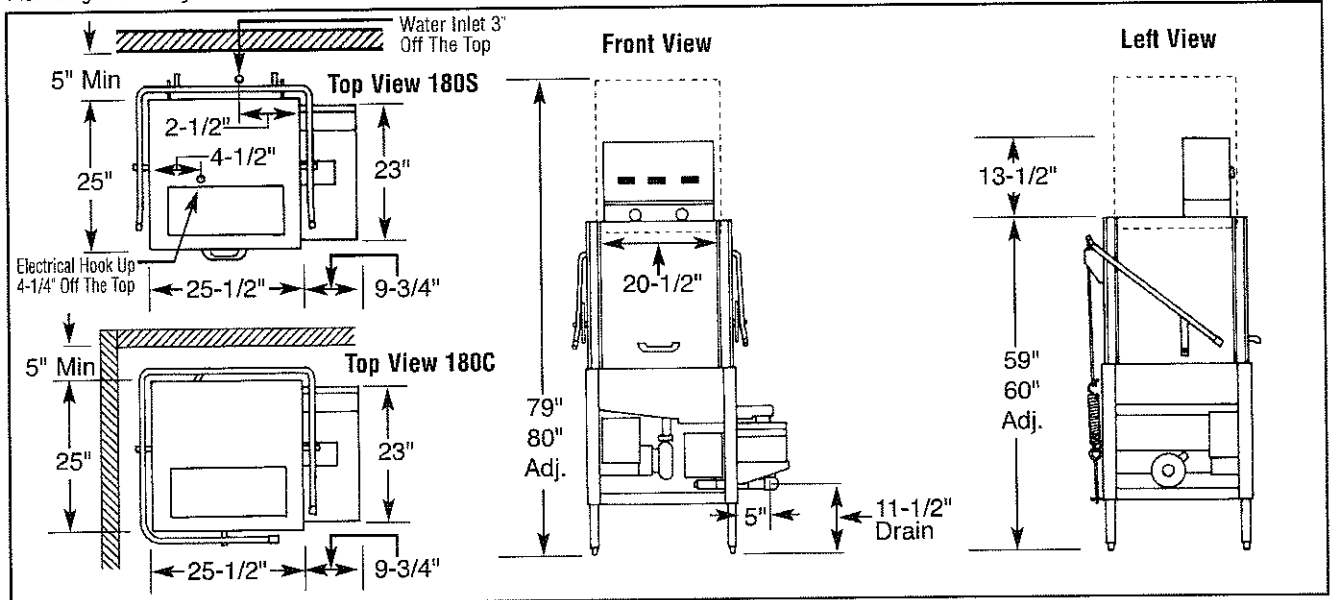

Specifications:

MODEL CMA-180	USA	METRIC	USA	METRIC
WATER CONSUMPTION				
PER RACK	.96 GAL	(3.6 L)		
PER HOUR	52 GPH	(197 L)		
OPERATING CYCLE				
WASH TIME - SEC.	49	49		
RINSE TIME - SEC.	12	12		
TOTAL CYCLE	61	61		
OPERATING CAPACITY				
RACKS PER HOUR	60	60		
WASH TANK CAPACITY	8 GAL.	(30.3 L)		
PUMP CAPACITY	52 GPM	(197 LPM)		
WATER REQUIREMENTS				
WITHOUT BOOSTER HEATER	180°F	(82°C)		
WITH BOOSTER HEATER	140°F	(60°C)		
WATER INLET	3/4"	(1.9cm)		
DRAIN CONNECTION	2"	(5.1cm)		
RINSE PRESSURE SET	20 ± 5psi	(1.41 kg/cm ²)		
OPERATING TEMPERATURE				
WASH-°F (MIN)	155°F-160°F	(68°C-71°C)		
RINSE-°F (MIN)	180°F-195°F	(82°C-90°C)		
WASH PUMP MOTOR HP			1	1
DIMENSIONS				
DEPTH			25"	(63.5cm)
WIDTH			25-1/2"	(65cm)
HEIGHT			59"-60"	(150-152cm)
STANDARD TABLE HEIGHT			34"	(86.3cm)
MAX CLEARANCE FOR DISHES			17-1/2"	(44cm)
DRAIN CONNECTION (OFF FLOOR)			11-1/2"-12-1/2"	(29-32cm)
STANDARD DISHRACK DIMENSIONS			1	1
			19-3/4" X 19-3/4"	(50X50cm)
ELECTRICAL RATING				
WITHOUT BOOSTER	VOLTS		PHASE	AMPS
	208		1	28
	240		1	30
	208		3	19
	240		3	21
WITH BOOSTER	208		3	9
	240		1	71
	240		1	80
	208		3	45
	240		3	50
480		3	23	
SHIPPING WEIGHT				
WITHOUT BOOSTER			332#	(151kg)
WITH BOOSTER			375#	(170kg)

Summary Specifications: Model CMA-180

The model CMA-180 single tank, high temperature dishwasher is designed for years of trouble free service, producing sparkling results while conserving energy, water and chemicals. This machine is available with an optional "built in" booster heater, assuring a continuous supply of 180°F hot water, and is easily field convertible for either corner or straight installation. Unique soil purging system filters wash water and plate debris into an external tray. The CMA-180 is NSF, UL, CUL and CE approved. Constructed entirely of stainless steel.

Available Models

- CMA-180S Straight
- CMA-180SB Straight with booster
- CMA-180C Corner
- CMA-180CB Corner with booster

Available Options:

- Exhaust Fan Time Control
- Built-in 12kW booster heater
- CMA-180 Conversion Kit Corner to Straight
- CMA-180 Conversion Kit Straight to Corner
- Alternative electrical available for export

- Stainless steel dishtables
- Dual power supply connections



NOR-LAKE, INCORPORATED
 727 Second Street
 P.O. Box 248
 Hudson, WI 54016

800-955-5253
 715-386-2323
 866-961-5253 Parts
 800-388-5253 Service
 715-386-6149 FAX
 www.norlake.com

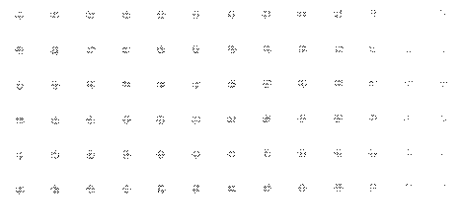
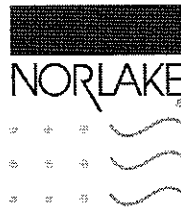

ADVANTEDGE™ REACH-IN REFRIGERATORS

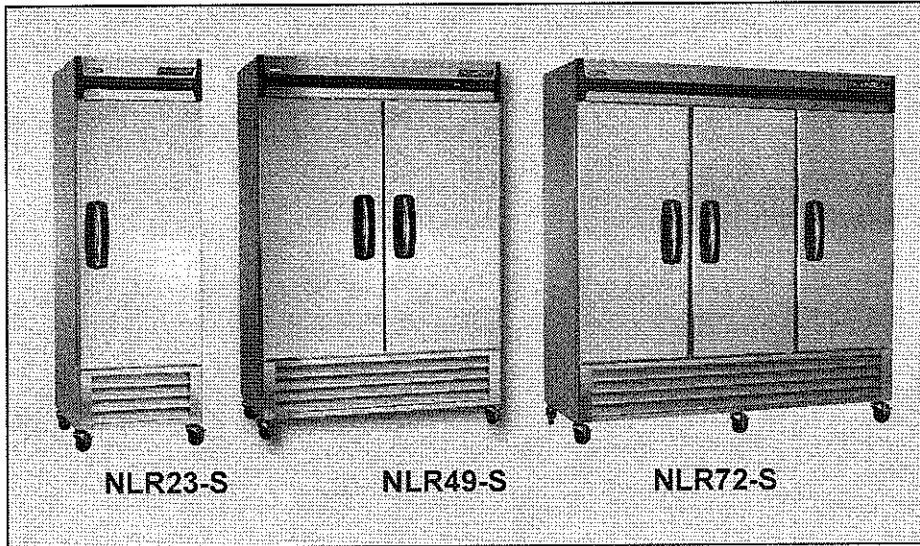

PROJECT: _____
 ITEM NUMBER: _____
 MODEL NUMBER: _____

1, 2 & 3 DOOR ADVANTEDGE™ REFRIGERATORS

SPECIFICATIONS FOR: NLR23-S, NLR49-S, NLR72-S

- **Exterior finish:** Exterior front sides and doors are stainless steel. The exterior top, bottom and back are galvanized steel.
- **Interior finish:** Interior liner and interior door panel are stainless steel
- **Insulation:** The complete cabinet and door(s) are foamed-in-place with polyurethane foam insulation.
- **Hardware:** Heavy duty, pivot hinges; key locks; curved handle with recessed pocket; self adjusting magnetic gaskets; 4" dia. casters (4 casters on one and two door models and 6 casters on three door model). 4 vinyl coated shelves per door section - standard.
- **Electrical:** An interior incandescent light is activated by a switch for each door.
- **Instrumentation:** Microprocessor with digital display allows temperature adjustment at control panel.
- **Refrigeration:** Complete bottom mounted refrigeration system with a copper tube, ceiling mount aluminum fin evaporator. The condensate is collected and automatically evaporated from an energy efficient air over wick style vaporizer. Drain line is recessed in cabinet back. Refrigerant flow is controlled by a capillary tube. R-134a refrigerant. Operating temperature: 36°F.
- **Approvals:** UL listed
 C-UL listed **
 ETL Sanitation
 ENERGY STAR ®

STANDARD FEATURES

- Air-cooled condensing unit
- Automatic condensate vaporizer
- Automatic defrost
- Casters
- Capillary tube system
- Curved handle with recessed pocket
- Door open alarm
- Interior light
- Key locks
- Magnetic gasket
- Microprocessor with digital display
- Operating temperature: 36°F
- Polyurethane insulation
- R-134a refrigerant
- Stainless steel interior and exterior
- Vinyl coated shelves
- UL, C-UL, ETL Sanitation & ENERGY STAR ®
- Warranties: 1 year parts labor/ service 5 year compressor

OPTIONAL FEATURES

- Extra shelves
- Pan slide rack (part # 146515)



Nor-Lake, Inc.
 Registered to ISO 9001:2008
 File No. 10001816

** C-UL is Underwriters Laboratories Safety Certification Mark which indicates that UL has tested the equipment to applicable CSA Standards.

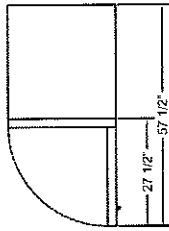

NLR23-S Top View

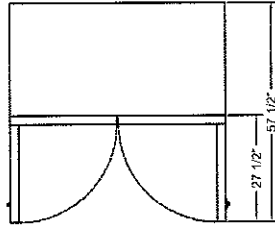

NLR49-S Top View

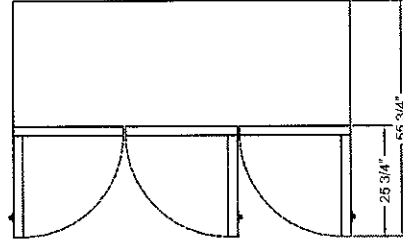

NLR72-S Top View

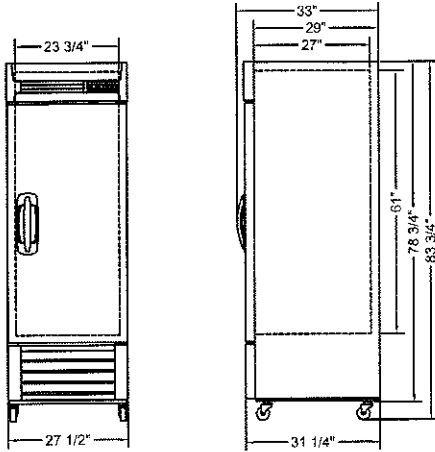

NLR23-S Front and Side Views

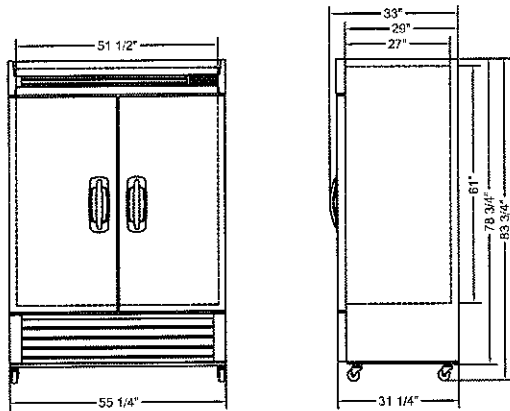

NLR49-S Front and Side Views

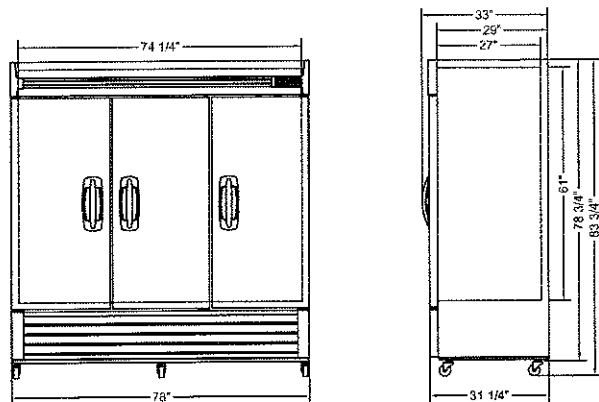

NLR72-S Front and Side Views

SPECIFICATIONS

	<i>NLR23-S</i>	<i>NLR49-S</i>	<i>NLR72-S</i>
<i>Crated Height</i>	84- 1/4"	84-1/4"	84-1/4"
<i>Crated Width</i>	29- 1/8"	56-3/4"	78- 3/8"
<i>Crated Depth</i>	33/ 1/2"	33-1/2"	33-1/2"
<i>Crated Weight (lbs)</i>	297	451	607
<i>Interior Height (in)</i>	61"	61"	61"
<i>Interior Width (in)</i>	23- 3/4"	51-1/2"	74- 1/4"
<i>Interior Depth (in)</i>	27"	27"	27"
<i>Overall Height (in)</i>	83- 3/4"	83-3/4"	83- 3/4"
<i>Overall Width (in)</i>	27- 1/2"	55-1/4"	78"
<i>Overall Depth (in)</i>	33"	33"	33"
<i>Gross Cubage (ft. ³)</i>	23	49	70
<i>Number of Shelves</i>	4	8	12
<i>Number of Casters</i>	4	4	6
<i>Condensing Unit Size</i>	3/8 HP	3/8 HP	1/2 HP
<i>Refrigerant</i>	R-134a	R-134a	R-134a
<i>Electrical Characteristics</i>	115/60/1	115/60/1	115/60/1
<i>Cord & Plug Furnished</i>	Yes	Yes	Yes
<i>NEMA Plug Configuration</i>	5-15P	5-15P	5-15P
<i>Total Amp Draw</i>	7.5	7.5	10

* The overall heights shown in the table and drawings are with casters.

Specifications subject to change without notice.



Revision Date: 11/10
 © 2010 NOR-LAKE, INC.
 Printed in the U.S.A.
 Part Number: 138688



Arctic®

Walk-ins

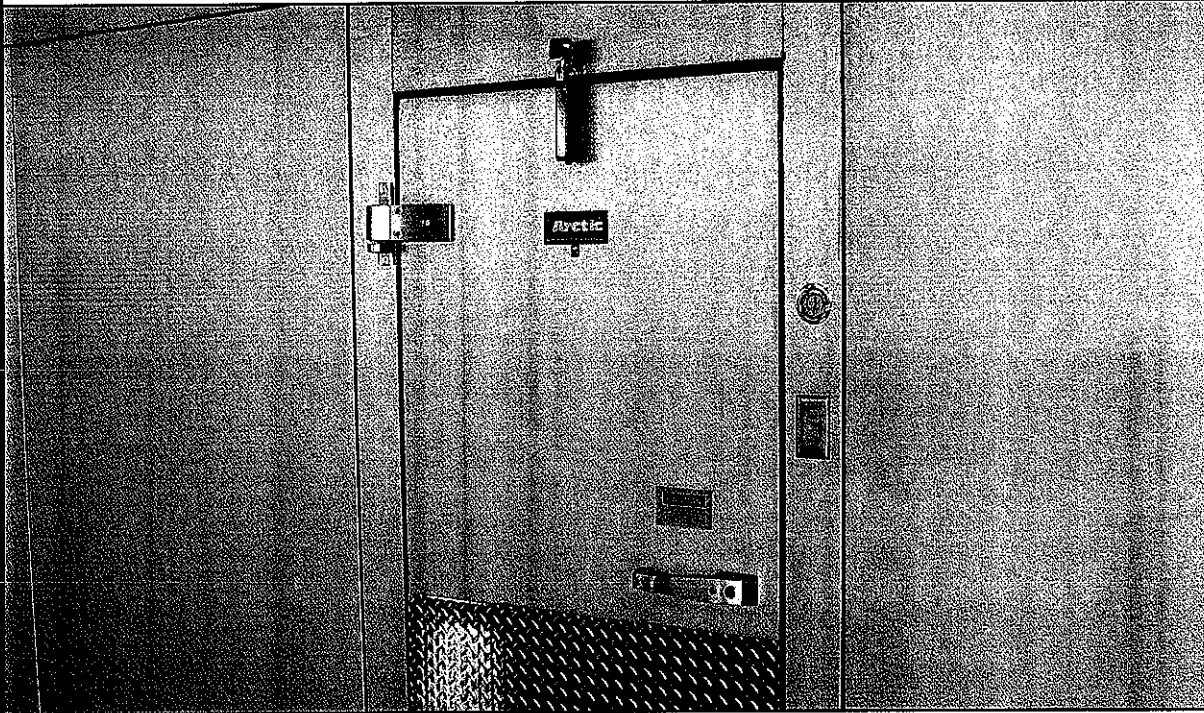
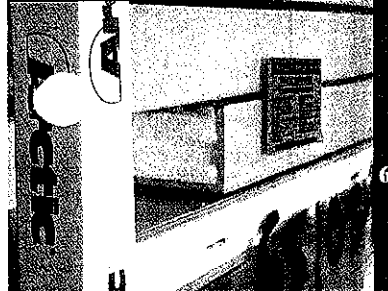
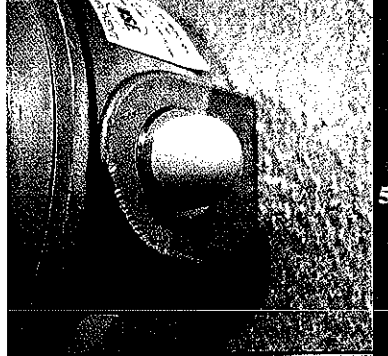
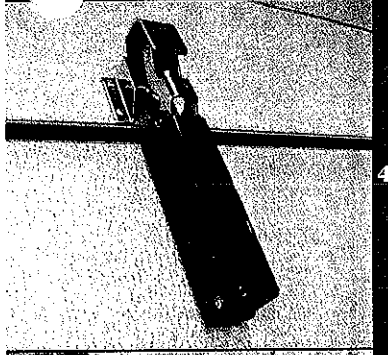
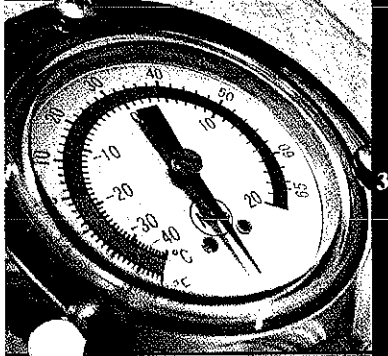
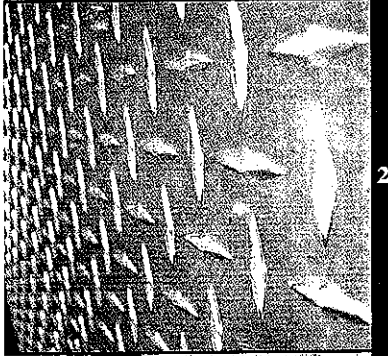
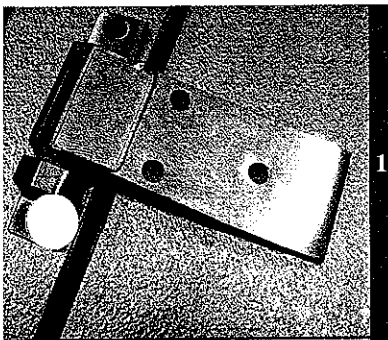

www.arcticwalk-ins.com

Image Key

- 1 Cam lift hinges with heavy aluminum backing plate
- 2 Diamond tread aluminum interior/exterior kick plate
- 3 Dial thermometer
- 4 Hydraulic closure
- 5 Interior safety night light
- 6 Extra packing to protect unassembled components.

The Arctic Advantage

- Boxes preassembled before shipping
- 1 piece corners
- Thermo disc controlled door heater
- Full service CAD designs
- Custom sizes and odd configurations

10 year panel warranty, 5 year compressor warranty, 1 year parts & labor warranty

9731 N.W. 114th Way
Miami, FL 33178

Phone: 305.883.5581
800.325.0123

Fax: 305.883.4651



FOAMED-IN-PLACE PANELS

GENERAL SPECIFICATIONS

WALK-IN REFRIGERATED ROOMS

1. WALK-IN COOLERS/FREEZERS:

- A. Walk-in refrigerated rooms shall be as manufactured by Arctic Industries, Inc.
- B. Supply prefabricated walk-in refrigerated rooms, all metal clad, sectionally constructed in nominal flexible widths, with inside finish height to suit requirements, designed for easy and accurate field assembly with provisions to facilitate disassembly for relocation, and for addition of extra sections to increase size.
- C. Foamed-in-place wall panels are available in 12" increments. Maximum single foamed-in-place panel height 13' 10 1/4". Standard foamed-in-place wall panel widths are 11 1/2", 23", 34 1/2" and 46". Foamed-in-place corners are available in same heights as foamed-in-place wall panels with outside widths of 12" x 12", 23 1/2" x 23 1/2".

2. SHOP DRAWINGS:

Shall be submitted for approval prior to fabrication.

3. MATERIALS:

A. Section Construction:

Insulated panels shall be UL listed and approved with UL certifying label on each panel. Panels shall be of foamed-in-place urethane insulation "sandwiched" between interior and exterior metal covering to suit project specifications. Standard foamed-in-place finish is 26 gauge stucco embossed galvalume steel with a clear acrylic coating to enhance brightness and maintain durability.

Optional metal finishes are as follows:

- Stucco embossed aluminum
- Pre-painted white stucco embossed galvalume
- Stainless steel

B. Panel Seams:

Panel edges shall be foamed-in-place tongue and groove with locking mechanisms foamed-in-place at time of fabrication. Gasket shall be resistant to oil, fats, water, detergents and sunlight and must be NSF approved. Panel gaskets shall incorporate a double 90 degree return formed behind the metal edge of the panel to ensure permanency of gasket. Stapled or glued gaskets shall not be accepted. The use of caulking compound to seal panel seams shall not be accepted.

C. **Section Insulation:**

Each panel shall be filled with rigid "foamed-in-place" urethane with a minimum density of 2.2 lbs per cu. ft. Urethane shall be poured, not frothed. Non-CFC's shall be used as the expanding agent in the manufacturing process. Urethane insulation shall have thermal conductivity ("K" factor) of not more than 0.12 BTU per hour per square foot per degrees Fahrenheit per inch. "R" factor is 33.

Overall thickness shall be 4". Insulation shall be 97% closed cell structure. Insulation core shall have 25 Flame Spread Rating with Average Smoke Rating less than 150, conforming to ASTM E-84 (U.L. 723). Test results are not intended to reflect hazards presented by this or any other material under actual fire conditions.

D. **Floors:**

1. Where prefabricated floors are called for, floor sections shall be similar to wall sections, but the inside shall be 16 gauge galvanized steel for standard floors and .100 aluminum for N.S.F. approved floors. Floors are capable of supporting distributed floor load of 700 lbs per square ft.

2. Where mass insulation is called for, floors shall consist of rigid polystyrene or rigid urethane placed in two layers, with thickness to suit unit requirements, set dry with staggered joints, over Visqueen (0.004) vapor barrier. Insulation shall be placed on recessed concrete sub-slab, as shown on shop drawings. Finish floors inside all walk-ins shall be by others. Finish floors shall be set over protective barrier of Visqueen on top of insulation. Lap Visqueen up walls two feet to protect walls. Visqueen shall be trimmed clean, after concrete is poured, by others. All concrete shall be placed after walk-ins are installed. Concrete work and perimeter grouting shall be installed by others.

4. **ENTRANCE DOOR AND DOOR PANEL:**

Standard door openings shall be 34" x 78". Door shall be swing-type, in fitting, flush mount. Finish of doors and door panels shall match adjacent wall panels. Doors shall be UL listed and approved; UL listing label shall be affixed to each door. Doors and door panels shall be insulated with foamed-in-place urethane insulation. Wood framing shall not be used in door or door panel. Doors shall be equipped with the following:

A. Perimeter of door jamb (opening) shall be constructed of high impact, reinforced plastic, foamed-in-place. Material shall be non-conductive, corrosion-proof, impact-resistant and will not absorb moisture. Material shall be coved to facilitate easy cleaning. Protective material shall return 1 3/4" on the inside of door frame.

B. Door jamb shall be trimmed with a strip of magnetically attracting stainless steel. This strip shall provide perfect sealing of magnetic gasket to prevent frost and condensation build-up. No visible fasteners shall be used to secure the stainless cover strip. Stainless strip shall be snap-on type and shall be easily removable and replaceable.

C. Freezer door only shall include a low wattage heater beneath the stainless steel cover strips on door jamb. Heater cable to be connected to SEPARATE CIRCUIT. Heater amperage equals 0.5 amps, 115 volts, 60 cycles. Door heater shall consist of a molded heater harness assembly. Lead connectors shall be machine applied, with water-tight silicone insulated over-mold. A butt splice, hand applied connector shall not be accepted. All door heater assemblies shall be factory wired to an energy-efficient heat sensing disk thermostat. This device will interrupt door heater operation when the room temperature is above 55 degrees.



FOAMED-IN-PLACE PANELS

- D. Fahrenheit and resume operation of the heaters when the room temperature is below 35 degrees Fahrenheit.
- E. Doors shall include thermoplastic gasket with a magnetic steel core and shall be mounted on the top edge and along both sides of the door. Bottom of door shall contain a dual blade flexible rubber wiper gasket. Wiper gaskets shall be retained within non-conducting PVC extrusion track and shall be easily replaceable and easy to clean. Magnetic gasket shall be bullet dart type to snap in and out of integral track for easy replacement.
- F. Door hardware shall include one pair of strap-type self-closing hinges, cam lift design, mounted onto 1/4" steel plates with stainless steel bolts, hydraulic door closer and door latch. Door latch shall be pull type to break the force of the magnetic gasket. Latch shall include a keyed cylinder lock mechanism. An inside safety release handle shall be included which will operate to prevent entrapment by overriding the cylinder key lock. Each door shall include 36" high diamond tread kick-plates, interior and exterior.
- G. Each door panel shall include an interior vapor proof light with globe, guard, and flush mounted switch with pilot light on the exterior. The vapor proof light shall include a night light. When the light switch is set to the "off" position a three-watt light bulb, factory installed in the vapor proof light fixture, will provide a continuous glow of light. Concealed wiring within conduit shall be used between light and switch.
- H. One NSF approved remote dial thermometer shall be flush mounted in door panel.
- I. Door threshold plates, where required, shall be 16 gauge galvanized steel for standard application, .100 aluminum for NSF approved application.

5. SPECIAL PROVISIONS:

- A. National Sanitation Foundation: Walk-ins shall be fabricated to comply with National Sanitation Foundation Standard #7. The NSF listing label shall be affixed to each door.
- B. Pressure Relief Port: A pressure relief port shall be provided for each freezer to equalize pressure differences caused by door openings and the defrosting of coils. The relief port shall be heated to prevent frost accumulation..
- C. Section Construction: White stucco embossed aluminum, galvalume, galvanized steel, white smooth or stucco galvanized steel, paint prep galvanized steel or stainless steel, optional colors are also available.
- D. Closure and Trim Strips: Supply only closures or trim strips, as required. Closures or trim strips shall be of the same material as the walk-in. Closures or trim strips shall be installed by others, to the finish walls and/or ceilings of the adjacent areas.
- E. Weatherproof Roof: For outdoor installation, a membrane roof cap shall be provided to protect ceiling panels from water accumulation.

F. Shelving and Supports: Shelving shall be adjustable modular type furnished in the length, width, and tiers as required.

1. General: Shelving and uprights shall be approved by the National Sanitation Foundation under Standard #2 (*Available in aluminum and stainless steel*).

G. Refrigeration:

1. Pre-charged, self-contained, package, refrigeration units, top or side-mounted.
2. Component parts of remote refrigeration systems including all accessories excluding refrigeration lines and refrigerant.
3. Pre-assembled remote.
4. Pre-assembled remote with pre-charged quick connect lines.

6. **INSTALLATION INSTRUCTIONS:**

A complete set of installation instructions shall be included with the walk-ins. These instructions shall cover the erection and assembly of the walk-in, and the installation of refrigeration systems if supplied by Arctic. A floor plan print shall be included.

7. **WARRANTIES:**

- A. Walk-in coolers and freezers shall have a ten (10) year panel and door warranty, one (1) year original parts replacement warranty, excluding labor. See warranty statement for complete text.
- B. Refrigeration systems shall have a (5) year compressor warranty, a one (1) year parts warranty and a one (1) year refrigeration labor warranty. See warranty statement for complete text.

8. **WORK BY OTHERS:**

All electrical work, roof penetrations for refrigeration lines, shelving, condensate piping shall be by others. Floor areas to receive walk-ins are to be level and prepared by others.



WALK-IN COOLERS AND FREEZERS

STANDARD DOOR CONSTRUCTION

All Arctic walk-in doors and frames are re-inforced with high impact ABS plastic. This framing provides extra support and rigidity to prevent warping, racking, or twisting. By re-inforcing the doors and frames with this high impact material, three additional benefits are achieved:

The ABS lining reinforces the door and frame to resist the day in and day out pounding of carts, hand trucks and crates that are slammed into it.

The second benefit is one of thermal efficiency. ABS is an efficient insulator. The use of ABS in the door frame eliminates the need for heater wires on coolers by creating a thermal break between the warm metal skin of the walk-in on the outside and the cold metal skin on the inside. This thermal efficiency also enables Arctic to use very low wattage, less costly to operate, heater wires on our freezer doors. The heater wires are attached to a temperature sensing device that prevents overheating prior to start-up, seasonal shut-down, maintenance, or in the event of a compressor failure.

The third benefit of ABS is the ability to design and incorporate integral channels in the door and frame. The channel in the frame is designed to accept the armored heater wire and cover made with heavy gauge magnetic stainless steel. This cover is easily removable when necessary for access to the heater wire. The channel in the door is designed to accept easily replaceable snap-in and out magnetic gaskets.

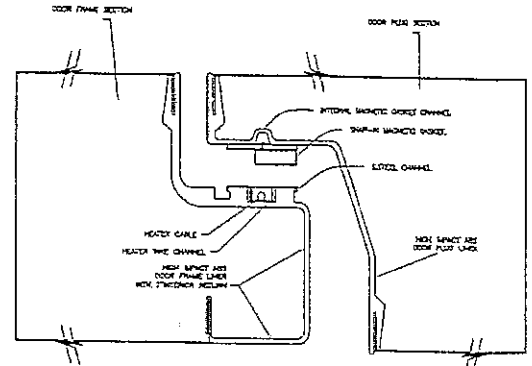

DOOR AND FRAME SECTION VIEW

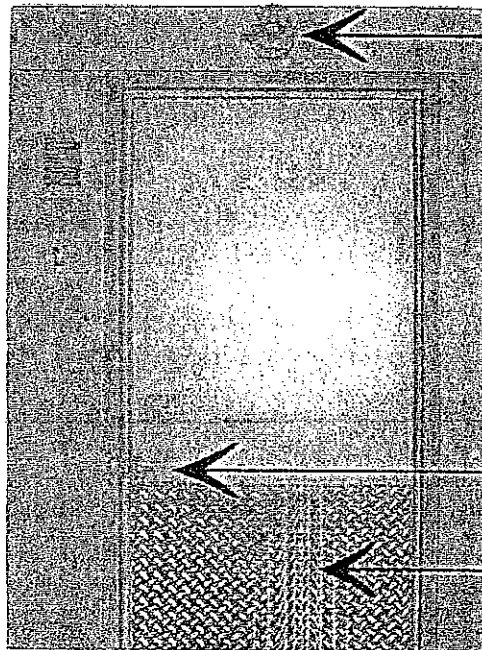

G & H Standard interior door hardware includes (G) a vapor proof dome light that is centered over the doors for efficient illumination. This placement also keeps the light out of the way of shelves and vinyl strip curtain hardware.

Arctic incorporates a (H) 5-watt safety night light into the dome light to eliminate the possibility of employees being accidentally left in complete darkness, unable to safely find their way to the door or the (I) safety release lever.

Arctic Industries, Inc.
9731 NW 114th Way
Miami, FL 33178
Phone: (305) 883-5581
1-800-328-0123



WALK-IN COOLERS AND FREEZERS

STANDARD DOOR CONSTRUCTION

The most important part of any walk-in is the door, as it is the only moving part. The Arctic hinged personnel door is designed intelligently and built to last. The door is U.L. listed and labeled and is recognized as one of the finest in the industry. Arctic hinged doors are covered under a 10 year warranty.

All Arctic hinged personnel doors are "foamed-in-place," in-fitting, self-closing, flush-mounted with magnetic gasket and modular design. The standard door is 34" x 78". The door section is interchangeable with most standard wall panels (consult factory for further detail). Arctic can easily design and place any of our doors almost anywhere in a wall, within 11" of the exterior corner on a 4" thick wall. Optional door sizes include:

- 25" x 78"
- 30" x 78"
- 36" x 78"
- 42" x 78"
- 48" x 78"

Arctic offers custom door sizes to meet any requirement.

All Arctic hinged personnel doors are foamed-in-place with CFC-free urethane foam. This manufacturing technique eliminates any structural wood in the door and enables Arctic to attach the door to the frame with (A) heavy-duty, self-closing, cam action, gravity hinges that are mounted onto 1/4" steel plates with machine bolts, ensuring maximum strength and eliminating sagging.

Door sections are internally pre-wired at the factory for 115-60-1. Field connections are made in the light fixture base, which serves as a junction box.

Standard exterior door hardware includes (B) 36" high aluminum diamond-tread kick-plates in and out, and (C) a heavy-duty locking door latch handle with a keyed cylinder lock.

All walk in doors include a factory installed (D) 2 1/2" dial thermometer and (E) pilot light with switch.

Doors are equipped with a (F) heavy-duty hydraulic door closer to ensure a gentle and complete door seal.

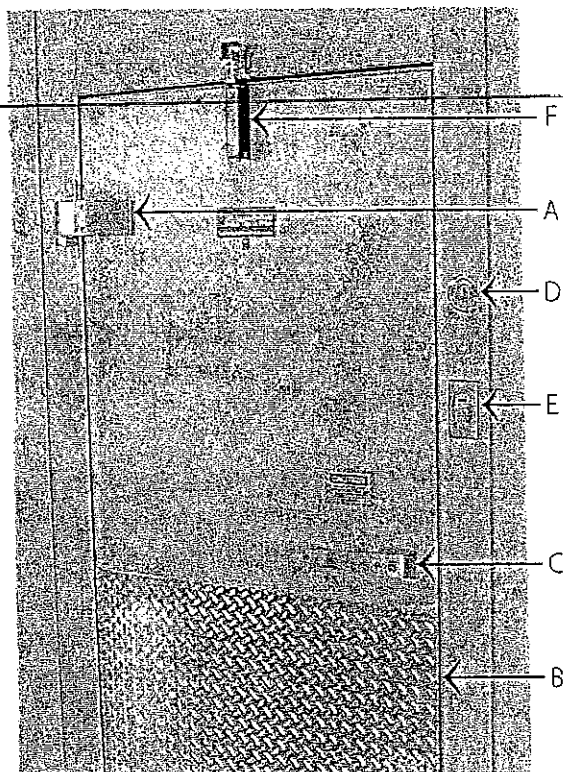

Arctic Industries, Inc.
9731 NW 114th Way
Miami, FL 33178
Phone: (305) 883-5581
1-800-328-0123
Fax: (305) 883-4651

Arctic[®] **REFRIGERATION**

Arctic Industries offers many choices of refrigeration. Every system is engineered to obtain the specific temperature required for the application. Refrigeration systems perfectly match the condensing unit to the evaporator coil for reliable and consistent operation.

Arctic offers four types of refrigeration systems:

- Remote
- Pre-assembled Remote
- Pre-assembled Remote with Pre-charged Quick-connect Lines
- Self-contained

All systems are available in:

- Low or medium temperature
- Indoor or outdoor models
- Air or water cooled condensers
- Hermetic or semi-hermetic compressors

Arctic is concerned with the effects of CFC's on our environment. After consultation with our component and refrigerant suppliers to determine which refrigeration systems would be the safest, most practical and cost efficient, R-22 systems for medium temperature applications and 404A for low temperature applications were selected.

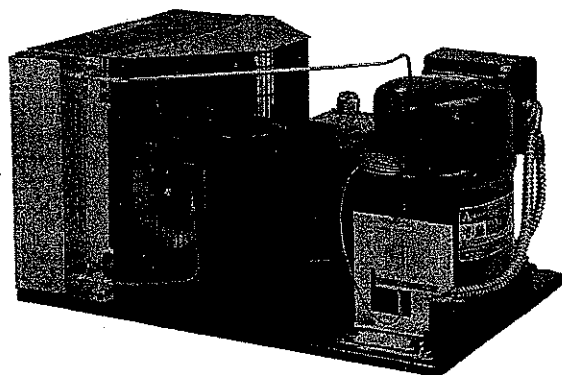

Arctic features Copeland and Tecumseh compressors matched to Russell and Heatcraft evaporators. These well known and reliable component manufacturers meet the most demanding specifications.

Arctic's team of skilled refrigeration technicians assemble self-contained & preassembled systems. Self-contained and pre-charged, quick-connect line systems are run tested prior to shipment.

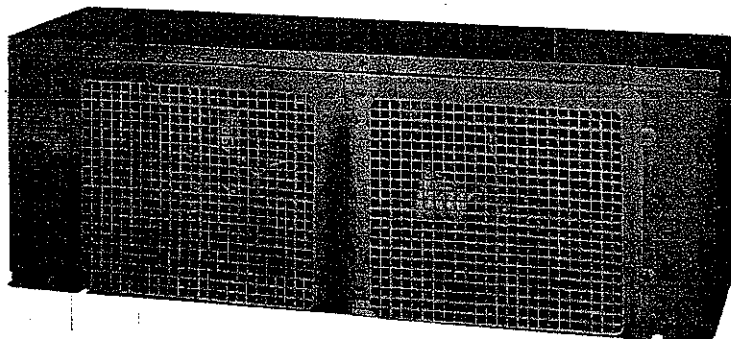

Arctic® REFRIGERATION

REMOTE SYSTEMS

Every component necessary for operation is shipped for field assembly. The components included are:

- Expansion valve • Pressure control
- Sight glass • Contactor (3 phase)
- Filter drier • Thermostat
- Drain line heater and solenoid valve
(low temp. only)

Lines, fittings, and refrigerant are not included.

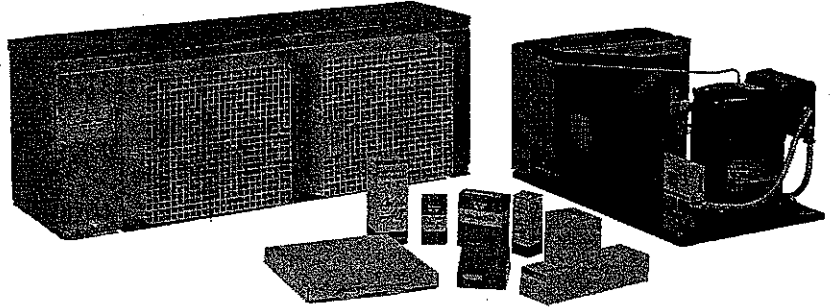

PRE-ASSEMBLED REMOTE SYSTEMS

Condensing units are completely assembled. All the components necessary for operation are factory mounted to ensure minimum field time for final hook up. Evaporator coils are ready to mount and are complete with properly matched expansion valve.

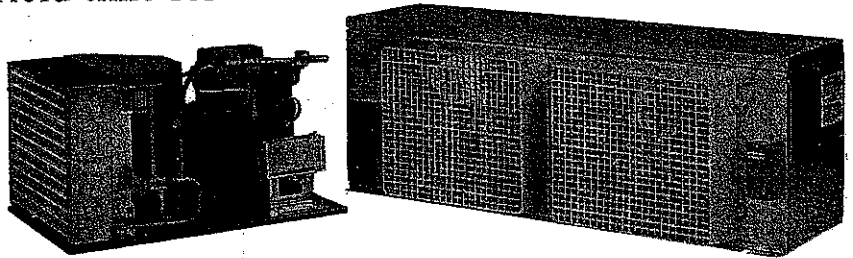

PRE-ASSEMBLED REMOTE WITH PRE-CHARGED QUICK-CONNECT LINES

Installation is quick and easy, as with the pre-assembled remote systems all components necessary for operation are factory mounted. Refrigeration line sets are pre-charged and simple to install with the quick-connect fittings. Standard pre-charged line sets are 25' in length. Systems include the electrical harness.

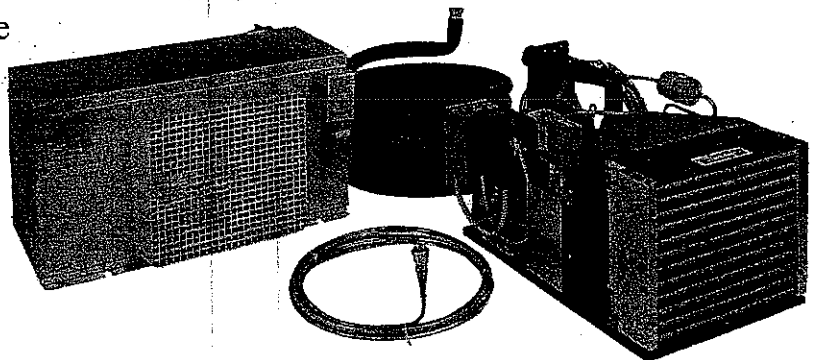

Arctic® REFRIGERATION

Arctic offers two types of pre-engineered, self-contained refrigeration systems.

SELF-CONTAINED TOP-MOUNT PLUG SYSTEM

Fast and economical to install, this system is designed for indoor applications only. Pre-charged and pre-assembled condensing units and evaporators are mounted to a section of the ceiling panel matched to fit a corresponding ABS framed opening in the ceiling. Ceiling mount units drop into place and seal automatically, ready to accept the final electrical hook-up and drain line (not included). A pre-wired fan cut-off switch is included on all plug systems. Low temperature plug systems include drain line heat tape. All plug systems are pre-wired, run-tested and ready for installation.

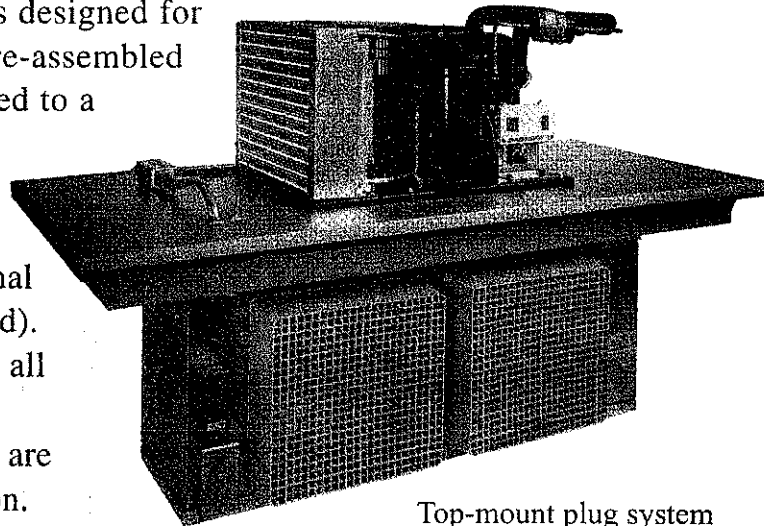

Top-mount plug system

STRADDLE-MOUNT SYSTEMS (ceiling and wall mount)

Fast and economical to install, these systems are designed primarily for outdoor applications. The straddle mount system makes installation fast and economical. The Arctic straddle mount refrigeration systems include a pre-wired fan cut-off switch.

Ceiling-mount straddle system

Condensing units are perfectly matched to evaporators to provide

consistent and reliable operation. Systems are mounted on reinforced steel frames. These frames are designed to drop into a factory notched wall panel then the ceiling panel is put in place. Straddle-mount systems are completely pre-assembled, pre-wired, pre-charged and factory run tested.

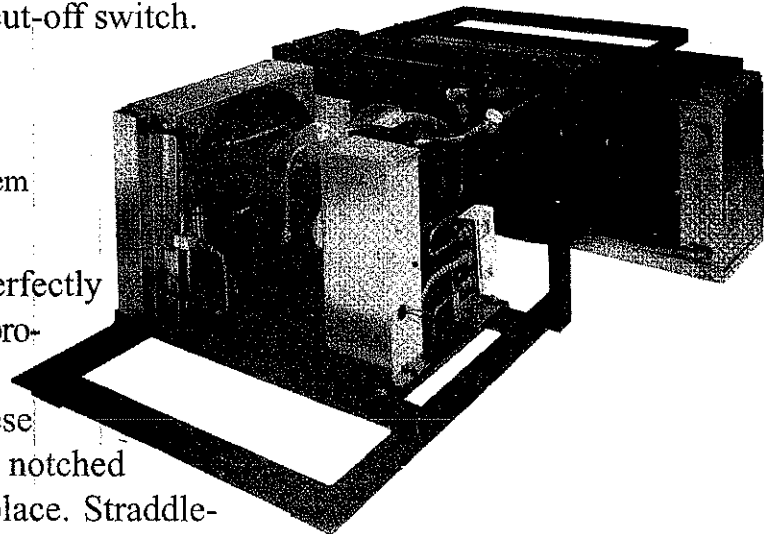

Wall-mount straddle system