



State of West Virginia
 Department of Administration
 Purchasing Division
 2019 Washington Street East
 Post Office Box 50130
 Charleston, WV 25305-0130

Request for Quotation

RFQ NUMBER
 DNR211136

PAGE
 1

ADDRESS CORRESPONDENCE TO ATTENTION OF:
 FRANK WHITTAKER
 304-558-2316

RFQ COPY
 TYPE NAME/ADDRESS HERE

V
E
N
D
O
R

Middletown Tractor Sales
 2345 Whitehall Blvd.
 Fairmont, WV 26554

S
H
I
P
T
O

DIVISION OF NATURAL RESOURCES
 JOBSITE
 SEE SPECIFICATIONS

DATE PRINTED	TERMS OF SALE	SHIP VIA	FOB	FREIGHT TERMS
03/10/2011	Net 30 Days	Our Truck	Destination	Pre-Paid
BID OPENING DATE: 04/06/2011		BID OPENING TIME 01:30PM		

LINE	QUANTITY	UOP	CAT NO.	ITEM NUMBER	UNIT PRICE	AMOUNT
0001	1	EA		020-89	\$36,113.00	\$36,113.00
TRACTORS, FARM, WHEEL TYPE						
0002	1	EA		020-02	7,464.99	7,464.99
BACKHOE FOR FARM TRACTOR						
<p>THE WEST VIRGINIA PURCHASING DIVISION, FOR THE AGENCY, THE WEST VIRGINIA DIVISION OF NATURAL RESOURCES, IS SOLICITING BIDS FOR A 4 WHEEL DRIVE TRACTOR WITH A BACKHOE ATTACHMENT FOR THE SHENANDOAH WILDLIFE MANAGEMENT AREA IN PENDLETON COUNTY, WV PER THE ATTACHED SPECIFICATIONS.</p> <p>ALL TECHNICAL QUESTIONS MUST BE SUBMITTED IN WRITING TO FRANK WHITTAKER IN THE WV PURCHASING DIVISION VIA EMAIL AT FRANK.M.WHITTAKER@WV.GOV OR VIA FAX AT 304-558-4115. DEADLINE FOR TECHNICAL QUESTIONS IS 03/22/2011 AT 4:00 PM. ALL TECHNICAL QUESTIONS WILL BE ADDRESSED BY ADDENDUM AFTER THE DEADLINE.</p> <p>BANKRUPTCY: IN THE EVENT THE VENDOR/CONTRACTOR FILES FOR BANKRUPTCY PROTECTION, THE STATE MAY DEEM THE CONTRACT NULL AND VOID, AND TERMINATE SUCH CONTRACT WITHOUT FURTHER ORDER.</p> <p>THE MODEL/BRAND/SPECIFICATIONS NAMED HEREIN ESTABLISH THE ACCEPTABLE LEVEL OF QUALITY ONLY AND ARE NOT</p>						

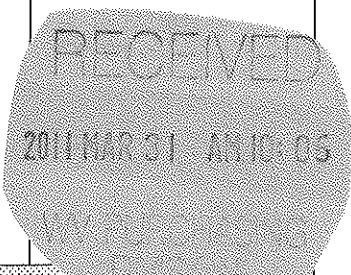

SEE REVERSE SIDE FOR TERMS AND CONDITIONS

SIGNATURE	TELEPHONE	DATE
<i>[Signature]</i>	304-366-4690	28 March 2011
TITLE	FERN	ADDRESS CHANGES TO BE NOTED ABOVE
Sales Consultant	55-054-7175	

WHEN RESPONDING TO RFQ, INSERT NAME AND ADDRESS IN SPACE ABOVE LABELED 'VENDOR'

**GENERAL TERMS & CONDITIONS
REQUEST FOR QUOTATION (RFQ) AND REQUEST FOR PROPOSAL (RFP)**

1. Awards will be made in the best interest of the State of West Virginia.
2. The State may accept or reject in part, or in whole, any bid.
3. Prior to any award, the apparent successful vendor must be properly registered with the Purchasing Division and have paid the required \$125 fee.
4. All services performed or goods delivered under State Purchase Order/Contracts are to be continued for the term of the Purchase Order/Contracts, contingent upon funds being appropriated by the Legislature or otherwise being made available. In the event funds are not appropriated or otherwise available for these services or goods this Purchase Order/Contract becomes void and of no effect after June 30.
5. Payment may only be made after the delivery and acceptance of goods or services.
6. Interest may be paid for late payment in accordance with the *West Virginia Code*.
7. Vendor preference will be granted upon written request in accordance with the *West Virginia Code*.
8. The State of West Virginia is exempt from federal and state taxes and will not pay or reimburse such taxes.
9. The Director of Purchasing may cancel any Purchase Order/Contract upon 30 days written notice to the seller.
10. The laws of the State of West Virginia and the *Legislative Rules* of the Purchasing Division shall govern the purchasing process.
11. Any reference to automatic renewal is hereby deleted. The Contract may be renewed only upon mutual written agreement of the parties.
12. **BANKRUPTCY:** In the event the vendor/contractor files for bankruptcy protection, the State may deem this contract null and void, and terminate such contract without further order.
13. **HIPAA BUSINESS ASSOCIATE ADDENDUM:** The West Virginia State Government HIPAA Business Associate Addendum (BAA), approved by the Attorney General, is available online at www.state.wv.us/admin/purchase/vrc/hipaa.htm and is hereby made part of the agreement. Provided that the Agency meets the definition of a Cover Entity (45 CFR §160.103) and will be disclosing Protected Health Information (45 CFR §160.103) to the vendor.
14. **CONFIDENTIALITY:** The vendor agrees that he or she will not disclose to anyone, directly or indirectly, any such personally identifiable information or other confidential information gained from the agency, unless the individual who is the subject of the information consents to the disclosure in writing or the disclosure is made pursuant to the agency's policies, procedures, and rules. Vendor further agrees to comply with the Confidentiality Policies and Information Security Accountability Requirements, set forth in <http://www.state.wv.us/admin/purchase/privacy/noticeConfidentiality.pdf>.
15. **LICENSING:** Vendors must be licensed and in good standing in accordance with any and all state and local laws and requirements by any state or local agency of West Virginia, including, but not limited to, the West Virginia Secretary of State's Office, the West Virginia Tax Department, and the West Virginia Insurance Commission. The vendor must provide all necessary releases to obtain information to enable the director or spending unit to verify that the vendor is licensed and in good standing with the above entities.
16. **ANTITRUST:** In submitting a bid to any agency for the State of West Virginia, the bidder offers and agrees that if the bid is accepted the bidder will convey, sell, assign or transfer to the State of West Virginia all rights, title and interest in and to all causes of action it may now or hereafter acquire under the antitrust laws of the United States and the State of West Virginia for price fixing and/or unreasonable restraints of trade relating to the particular commodities or services purchased or acquired by the State of West Virginia. Such assignment shall be made and become effective at the time the purchasing agency tenders the initial payment to the bidder.

I certify that this bid is made without prior understanding, agreement, or connection with any corporation, firm, limited liability company, partnership, or person or entity submitting a bid for the same material, supplies, equipment or services and is in all respects fair and without collusion or fraud. I further certify that I am authorized to sign the certification on behalf of the bidder or this bid.

INSTRUCTIONS TO BIDDERS

1. Use the quotation forms provided by the Purchasing Division. Complete all sections of the quotation form.
2. Items offered must be in compliance with the specifications. Any deviation from the specifications must be clearly indicated by the bidder. Alternates offered by the bidder as **EQUAL** to the specifications must be clearly defined. A bidder offering an alternate should attach complete specifications and literature to the bid. The Purchasing Division may waive minor deviations to specifications.
3. Unit prices shall prevail in case of discrepancy. All quotations are considered F.O.B. destination unless alternate shipping terms are clearly identified in the quotation.
4. All quotations must be delivered by the bidder to the office listed below prior to the date and time of the bid opening. Failure of the bidder to deliver the quotations on time will result in bid disqualifications: Department of Administration, Purchasing Division, 2019 Washington Street East, P.O. Box 50130, Charleston, WV 25305-0130
5. Communication during the solicitation, bid, evaluation or award periods, except through the Purchasing Division, is strictly prohibited (W.Va. C.S.R. §148-1-6.6).



State of West Virginia
 Department of Administration
 Purchasing Division
 2019 Washington Street East
 Post Office Box 50130
 Charleston, WV 25305-0130

Request for Quotation

RFQ NUMBER
 DNR211136

PAGE
 2

ADDRESS CORRESPONDENCE TO ATTENTION OF:
 FRANK WHITTAKER
 804-558-2316

RFQ COPY
 TYPE NAME/ADDRESS HERE

VENDOR

SHIP TO

DIVISION OF NATURAL RESOURCES
 JOBSITE
 SEE SPECIFICATIONS

DATE PRINTED	TERMS OF SALE	SHIP VIA	F.O.B.	FREIGHT TERMS
03/10/2011				

BID OPENING DATE: 04/06/2011 BID OPENING TIME 01:30PM

LINE	QUANTITY	UOP	CAT NO	ITEM NUMBER	UNIT PRICE	AMOUNT
<p>INTENDED TO REFLECT A PREFERENCE OR FAVOR ANY PARTICULAR BRAND OR VENDOR. VENDORS WHO ARE BIDDING ALTERNATES SHOULD SO STATE AND INCLUDE PERTINENT LITERATURE AND SPECIFICATIONS. FAILURE TO PROVIDE INFORMATION FOR ANY ALTERNATES MAY BE GROUNDS FOR REJECTION OF THE BID. THE STATE RESERVES THE RIGHT TO WAIVE MINOR IRREGULARITIES IN BIDS OR SPECIFICATIONS IN ACCORDANCE WITH SECTION 148-1-4 (F) OF THE WEST VIRGINIA LEGISLATIVE RULES AND REGULATIONS.</p> <p style="text-align: center;">NOTICE</p> <p>A SIGNED BID MUST BE SUBMITTED TO:</p> <p style="margin-left: 40px;">DEPARTMENT OF ADMINISTRATION PURCHASING DIVISION BUILDING 15 2019 WASHINGTON STREET, EAST CHARLESTON, WV 25305-0130</p> <p>THE BID SHOULD CONTAIN THIS INFORMATION ON THE FACE OF THE ENVELOPE OR THE BID MAY NOT BE CONSIDERED:</p> <p>SEALED BID</p> <p>BUYER: 44</p> <p>RFQ. NO.: DNR211136</p> <p>BID OPENING DATE: 04/06/2011</p> <p>BID OPENING TIME: 1:30 PM</p>						

SEE REVERSE SIDE FOR TERMS AND CONDITIONS

SIGNATURE	TELEPHONE	DATE
TITLE	FEIN	ADDRESS CHANGES TO BE NOTED ABOVE

WHEN RESPONDING TO RFQ, INSERT NAME AND ADDRESS IN SPACE ABOVE LABELED 'VENDOR'



State of West Virginia
 Department of Administration
 Purchasing Division
 2019 Washington Street East
 Post Office Box 50130
 Charleston, WV 25305-0130

Request for Quotation

RFQ NUMBER
 DNR211136

PAGE
 3

ADDRESS CORRESPONDENCE TO ATTENTION OF:
 FRANK WHITTAKER
 304-558-2316

RFQ COPY
 TYPE NAME/ADDRESS HERE

V
E
N
D
O
R

S
H
I
P
T
O

DIVISION OF NATURAL RESOURCES
 JOBSITE
 SEE SPECIFICATIONS

DATE PRINTED	TERMS OF SALE	SHIP VIA	FOB	FREIGHT TERMS
03/10/2011				

BID OPENING DATE: 04/06/2011 BID OPENING TIME 01:30PM

LINE	QUANTITY	UOP	CAT NO	ITEM NUMBER	UNIT PRICE	AMOUNT
PLEASE PROVIDE A FAX NUMBER IN CASE IT IS NECESSARY TO CONTACT YOU REGARDING YOUR BID: ----- 304-366-4698 ----- CONTACT PERSON (PLEASE PRINT CLEARLY): ----- Phillip A. Cottrille -----						
***** THIS IS THE END OF RFQ DNR211136 ***** TOTAL:						<u>\$43,578.⁰⁵</u>

SEE REVERSE SIDE FOR TERMS AND CONDITIONS

SIGNATURE	TELEPHONE	DATE
TITLE	FEIN	ADDRESS CHANGES TO BE NOTED ABOVE

WHEN RESPONDING TO RFQ, INSERT NAME AND ADDRESS IN SPACE ABOVE LABELED 'VENDOR'

The West Virginia Purchasing Division for the West Virginia Division of Natural Resources is requesting bids for the purchase of a Four Wheel Drive, Diesel Utility Tractor with Front End Loader and Backhoe Attachment. All items are to be F.O.B. Destination. Freight or delivery charges must be included in the price of the goods. Delivery must be made within thirty (30) days of purchase order award.

General Specifications:

The Four Wheel Drive, Diesel Utility Tractor with Front End Loader and Backhoe Attachment must be new (2011 model).

Information for Bidders:

Bidders must submit a unit price bid for each item to furnish all items specified.

Damaged Items:

Damaged or defective items must be replaced at no additional expense to The West Virginia Division of Natural Resources.

Warranty:

The equipment must be guaranteed to be free of defects in workmanship and material for a minimum of one (1) year from date of acceptance. However, if manufacturer warranty periods are longer than the required minimum one year warranty, those warranties shall apply.

Item #1 Four Wheel Drive, Diesel Utility Tractor with Front End Loader

John Deere Model 5075M Utility Tractor with John Deere Model 553 Front Loader, or equal.

Tractor must meet the following specifications:

- Must be four-wheel drive;
- Must have a minimum 75 horsepower diesel engine;
- Must have a minimum PTO horsepower of 60;
- Must have a synchronized hydraulic shuttle transmission (power reverser);
- Must have telescopic lower link ends and telescopic stabilizers on lift arms;
- Must have a front grill guard and brush guard;
- Must have operational lights;
- Must have a roll over protection system;
- Must have dual rear standard remote valves with lever controls;
- Must have a cold weather package;
- Must have an open operator station;

- Must have a drawbar and clevis attached;
- Must have general farming rated tires (R-1 grade);
- Must have all tires filled with Polyfil;
- Must have a power beyond coupler kit to accommodate backhoe attachment;
- Must include an operators manual and a demonstration of equipment must be provided upon delivery.

Front Loader must meet the following specifications:

- Must have a free standing quick attachment system for loader frame and bucket;
- Must have a minimum lift capacity of 2,000 pounds;
- Must have a minimum front end lift height of 10 feet;
- Must have a six-foot general purpose bucket;
- Must include two open center, mid-mounted loader valves with a four-way joystick.

Item #2 Backhoe Attachment

Bush Hog Model CBH 80 Backhoe or equal.

Backhoe attachment must meet the following specifications:

- Must attach to 3-point hitch system of tractor;
- Must attach to Power Beyond hydraulic couplings on tractor;
- Must have a digging depth of at least 8 feet;
- Must have a bucket cylinder digging force of at least 3800 pounds;
- Must have a dipperstick cylinder digging force of at least 2500 pounds;
- Must have cast flip over stabilizer pads;
- Must have an 18 inch commercial duty bucket with bolt on teeth with replaceable tips;
- Must have a fully adjustable operator's seat;
- Must have an operator's manual.

Tractor with Front End Loader and Backhoe to be delivered to the following location:

Headquarters
Shenandoah Wildlife Management Area – Pendleton County
Brandywine, WV 26802
Contact Chuck Waggy (304-358-7912) for delivery information

New 5M Series

65 - 105 Horsepower Utility Tractors



JOHN DEERE



Middletown Tractor Sales

2345 Whitehall Boulevard
Fairmont, WV 26554
(304) 366-4690
Exit 132 off I-79
www.middletowntractor.com

WARRANTY FOR NEW JOHN DEERE AGRICULTURAL PRODUCTS AND LIMITED WARRANTY FOR NEW JOHN DEERE COMMERCIAL & CONSUMER EQUIPMENT (U.S. Only)

- A. GENERAL PROVISIONS** - The warranties described below are provided by Deere & Company ("John Deere") to the original purchasers of new Agricultural and Commercial & Consumer Equipment from John Deere or authorized John Deere dealers. These warranties apply only to equipment intended for sale in the U.S. Under these warranties, John Deere will repair or replace, at its option, any covered part which is found to be defective in material or workmanship during the applicable warranty term. Warranty service must be performed by a dealer or service center located in the U.S. or Canada, and authorized by John Deere to sell and/or service the type of product involved, which will use only new or remanufactured parts or components furnished by John Deere. Warranty service will be performed without charge to the purchaser for parts or labor. The purchaser will be responsible, however, for any service call and/or transportation of product to and from the dealer's or service center's place of business, for any premium charged for overtime labor requested by the purchaser, and for any service and/or maintenance not directly related to any defect covered under the warranties below. Non-John Deere engines in self-propelled Forage Harvesters are warranted separately by their respective manufacturer. John Deere's Obligation shall not apply to Yanmar fuel injection pumps and nozzles during the original manufacturer's warranty period. When the pump manufacturer's warranty is less than the engine warranty, John Deere will provide warranty during the remainder of the original engine warranty period.
- B. WHAT IS WARRANTED** - All parts of any new John Deere product, except non-John Deere engines in self-propelled Forage Harvesters, tires, radios, and batteries (which are warranted under separate documents provided with each product), are warranted for the number of months or operating hours specified below.

AGRICULTURAL PRODUCTS		WARRANTY TERM	LAWN & GARDEN EQUIPMENT	WARRANTY TERM
TRACTORS	24 Months - Or 2,000 Hours Whichever Comes First *		1) All Lawn & Garden Equipment and Attachments and Compact Series Gators (except for equipment listed in 2 below)	24 Months in Private Residential - Personal Use 12 Months in Any Other Application
SCRAPERS	6 Months		2) 100, L100 and G100 Series Tractors and Attachments and Walk-Behind Mowers under 36"	24 Months in Private Residential - Personal Use 90 Days in Any Other Application
OTHER PRODUCTS, Including Ag Management Solutions (AMS) Products	12 Months		COMMERCIAL EQUIPMENT	
ENGINES IN SELF-PROPELLED PRODUCTS OTHER THAN TRACTORS	24 Months - Or 2,000 Hours Whichever Comes First		3) Wide Area Mowers, Front Mower Traction Units (with diesel or 20 HP and above engines), Z-TRAK Mowers, Commercial Walk Behind Mowers (36" or larger), and 7-IRON Mower Decks	24 Months
			4) Utility Tractors, Compact Utility Tractors	24 Months or 2000 Hours, Whichever Comes First
			a) Powertrain on Compact Utility Tractors (components as per B above)	36 Months or 2000 Hours, Whichever Comes First
			5) Gator Utility Vehicles (except Compact Series), Tractor Loader Backhoes (TLB), Other mower decks, implements, and attachments for Equipment listed in 3,4,5	12 Months or 1000 Hours, Whichever Comes First
			UTILITY ALL TERRAIN VEHICLES	
			6) Utility All Terrain Vehicles (UATV) and attachments	6 Months

Engine Items Covered - Engine block, cylinder head, rocker arm cover, timing gear cover, crankcase pan and all parts enclosed within these units. Also included are the fuel injection pump, turbocharger, water pump, torsional damper, manifolds and engine oil cooler.

Engine Items Not Covered during months 13 through 24 - Oil filler tube, engine filters and filter gaskets, air cleaners and associated parts, engine mounts and supports, all pulleys and belts, starter, alternator, linkage and cables, radiator, and hoses, engine oil lines, water piping, muffler and associated parts, fuel tank and associated parts, cold weather starting aids, fan and fan drives.

* Warranty Term for all tractors used in Earthmoving applications (other than those designated as "Scraper" tractors and ordered from the factory as such) is 90 Days.

Each warranty term begins on the date of product delivery to the purchaser (except for certain agricultural tillage, planting, cultivating, and harvesting products which may have a delayed warranty start date, but only if established by John Deere and noted by the dealer, on the purchase order).

Sweeps, Shovels, Plow Shares and Disk Blades - A replacement part will be furnished without charge if the following John Deere items break during the applicable warranty term, subject to these conditions:

SWEEPS & SHOVELS - When breakage occurs on items which do not show appreciable wear.

PLOW SHARES - When breakage occurs before the plow share reaches the following wear limits (labor not included - wear to be measured perpendicularly across the middle of the front bolt hole): INCH DIMENSION SHARES: 1/2 inch of wear (3 1/2 inches remaining); METRIC DIMENSION SHARES: 15mm of wear (100mm remaining).

DISK BLADES - When warrantable breaks occur as shown in the operator's manual on blades that have worn less than 10 percent of the original diameter (center breakage excluded).

WHEN APPLICABLE, A SEPARATE EMISSIONS WARRANTY STATEMENT WILL BE PROVIDED BY YOUR JOHN DEERE DEALER.

- C. WHAT IS NOT WARRANTED - JOHN DEERE IS NOT RESPONSIBLE FOR THE FOLLOWING:** (1) Used Products; (2) Frontier Equipment™ products. Warranty is the responsibility of the original manufacturer. The customer should contact a Frontier Equipment™ dealer for details; (3) Any product that has been altered or modified in ways not approved by John Deere: including, but not limited to, setting injection pump fuel delivery above John Deere specifications and modifying combine grain tanks; (4) Depreciation or damage caused by normal wear, lack of reasonable and proper maintenance, failure to follow the product's Operator Manual recommendations; (5) Normal maintenance parts and service including, but not limited to, oil, filters, coolants, and conditioners, cutting parts, belts, brake and clutch linings; (6) UATV if used for racing or any other competitive activity.

D. INCLUDED IN COMPACT UTILITY TRACTOR POWERTRAIN WARRANTY - Engine: cylinder block, cylinder head, valve covers, oil pan, timing gear covers, flywheel housing, and all parts contained therein (does not include fuel, electrical, cooling, intake or exhaust components). **Powertrain:** hydrostatic transmission, transmission case, differential and axle housings, clutch housings, MFWD front axle assembly, and all parts contained therein (does not include external drivelines, dry clutch parts, or steering cylinders).

E. SECURING WARRANTY SERVICE - To secure warranty service, purchaser must (1) report the product defect to an authorized dealer and request repair within the applicable warranty term, (2) present evidence of the warranty start date, and (3) make the product available to the dealer or service center within a reasonable period of time.

F. NO IMPLIED WARRANTY OR OTHER REMEDY - AGRICULTURAL PRODUCTS - Where permitted by law, neither John Deere or any company affiliated with it makes any warranties, representations, or promises, express or implied as to the quality or performance, or freedom from defect of its agricultural products other than those set forth above, and NO IMPLIED WARRANTY OF MERCHANTABILITY OR FITNESS IS MADE. IN NO EVENT WILL THE DEALER, JOHN DEERE OR ANY COMPANY AFFILIATED WITH JOHN DEERE BE LIABLE FOR INCIDENTAL OR CONSEQUENTIAL DAMAGES. The only remedies the purchaser has in connection with the breach of performance of any warranty on John Deere agricultural products are those set forth above.

G. LIMITATION OF IMPLIED WARRANTIES OR OTHER REMEDIES - COMMERCIAL & CONSUMER EQUIPMENT - To the extent permitted by law, neither John Deere nor any company affiliated with it makes any warranties, representations, or promises express or implied as to the quality, performance or freedom from defect of the Commercial & Consumer Equipment covered by this warranty. IMPLIED WARRANTIES OF MERCHANTABILITY AND FITNESS FOR A PARTICULAR PURPOSE, TO THE EXTENT APPLICABLE, SHALL BE LIMITED IN DURATION TO THE APPLICABLE PERIOD OF WARRANTY SET FORTH ON THIS PAGE. THE PURCHASER'S ONLY REMEDIES IN CONNECTION WITH THE BREACH OR PERFORMANCE OF ANY WARRANTY ON JOHN DEERE COMMERCIAL & CONSUMER EQUIPMENT ARE THOSE SET FORTH ON THIS PAGE. IN NO EVENT WILL THE DEALER, JOHN DEERE OR ANY COMPANY AFFILIATED WITH JOHN DEERE BE LIABLE FOR INCIDENTAL OR CONSEQUENTIAL DAMAGES. (Note: Some states do not allow limitations on how long an implied warranty lasts or the exclusion or limitation of incidental or consequential damages so the above limitations and exclusions may not apply to you.) In the event the above warranty fails to correct purchaser's performance problems caused by defects in workmanship and/or materials, purchaser's exclusive remedy shall be limited to payment by John Deere of actual damages in an amount not to exceed the amount paid for the product. This warranty gives you specific legal rights, and you may also have other rights which vary from state to state.

H. NO DEALER WARRANTY - THE SELLING DEALER MAKES NO WARRANTY OF ITS OWN AND THE DEALER HAS NO AUTHORITY TO MAKE ANY REPRESENTATION OR PROMISE ON BEHALF OF JOHN DEERE, OR TO MODIFY THE TERMS OR LIMITATIONS OF THIS WARRANTY IN ANY WAY.

I. If further information is desired, contact your selling dealer or DEERE & COMPANY MOLINE, IL at 1-866-993-3373.

WALLENSTEIN RANCHO GX BACKHOES



WALLENSTEIN
RANCHO

GX 920

For contractors and landscapers that need to dig deep, but not in their pockets, the **Ranchho GX920** makes the grade. The large GX920 extends the usefulness of 60-90HP tractors with digging capabilities of 9-feet deep. Trenching for footings and excavating to spec becomes quick and easy without the added expense of a single-purpose excavator. The digging bucket is built using AR400-strength steel, ensuring rugged longevity.

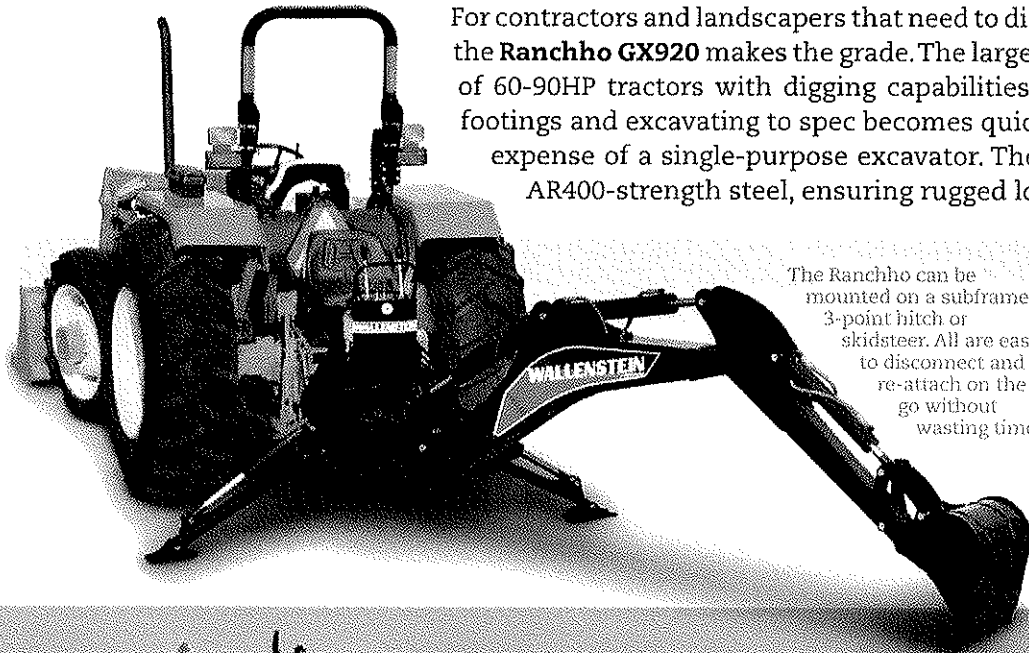

The Ranchho can be mounted on a subframe, 3-point hitch or skidsteer. All are easy to disconnect and re-attach on the go without wasting time.

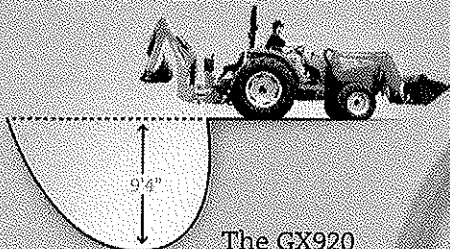

The GX920 provides a 2-foot flat bottom at the maximum digging depth.

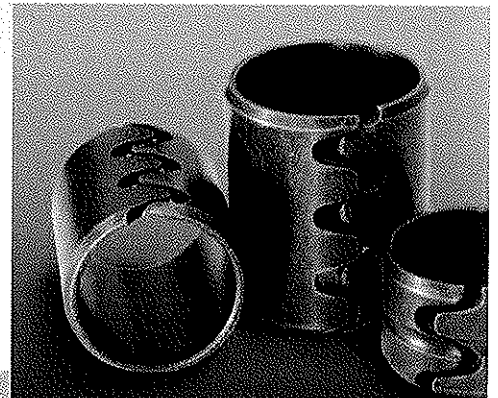
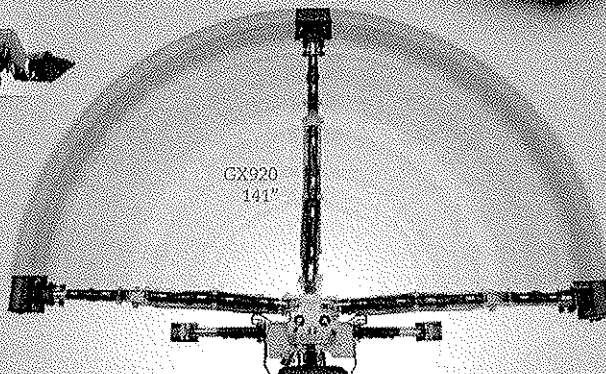

BUSHINGS

Hardened steel bushings are installed on all the main pivot points of the GX720 and GX920, including swing, boom, dipper and bucket. High quality bushings add life to the Ranchho by reducing the wear and tear as you dig and swing.

SPECIFICATIONS

*in accordance with SAE J1179 standard

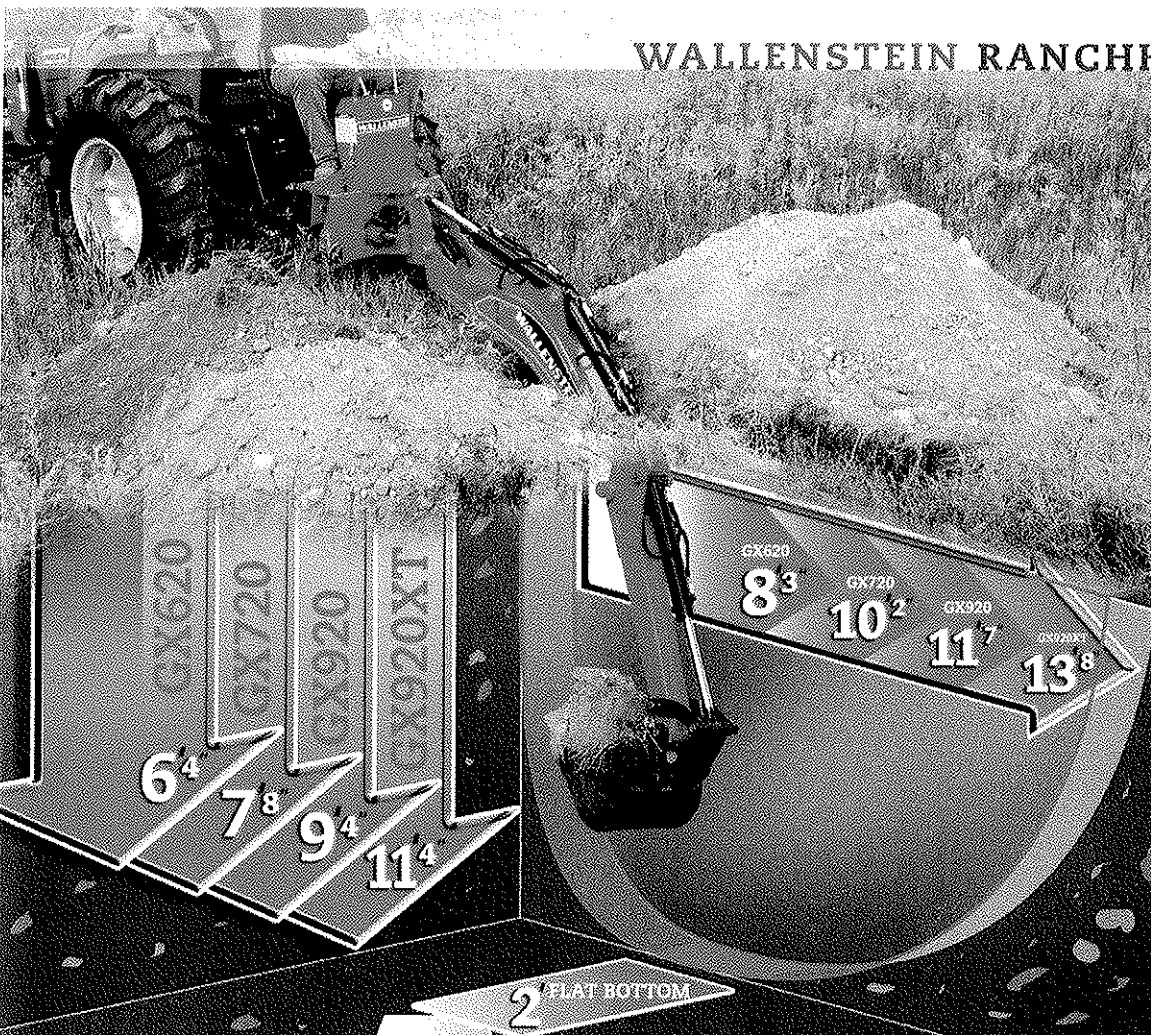

	GX620	GX720	GX920	GX920XT
A				
Transport Height (with boom fully retracted)	63"	79"	92"	92"
Transport Width (with stabilizers up)	40"	42 1/2"	42 1/2"	42 1/2"
Loading Height (bucket at 60° rotation)	62"	80"	89"	89"/104"
B				
Ground Clearance	10 1/2"	10 1/2"	10 1/2"	10 1/2"
C				
Transport Length	68"	80"	81"	81"
Transport Weight (base unit only - no bucket or mounts)	575 lbs.	765 lbs.	791 lbs.	980 lbs.
D				
Digging Depth (2 ft. flat bottom)	6'4"	7'8"	9'4"	9'4"/11'4"
E				
Overall Operating Height (fully raised)	92"	119"	135"	135"/152"
F				
Reach from Swing Post	100"	123"	141"	141"/164"
G				
Bucket Rotation	180°	180°	180°	180°
Swing Arc	180°	180°	180°	180°
Stabilizer Width (Spread)	74"	89"	89"	89"
Stabilizer Width (Transport)	40"	42 1/2"	42 1/2"	42 1/2"
Operating Pressure	1800 psi	2250 psi	2250 psi	2250 psi
SAE* Dipper Boom Digging Force	1250 lbs.	2300 lbs.	3200 lbs.	3100/2200 lbs.
SAE* Bucket Digging Force	2600 lbs.	3800 lbs.	3925 lbs.	3925 lbs.
Boom Lift Capacity (end of dipper 3' from ground)	385 lbs.	925 lbs.	750 lbs.	710/580 lbs.
Hydraulic Volume Requirements	5-7 gpm	5-7 gpm	5-7 gpm	5-7 gpm
Recommended Tractor HP	15-25 HP	22-45 HP	45-100 HP	45-100 HP
Recommended Skidsteer Requirements (SSQ)	Mini Skidsteer	30-60	30-100	30-100
Main Boom Cylinder Diameter	2 1/2"	3"	3"	3"
All Other Cylinder Diameters	2 1/4", 2" (stabs, swing)	3" (dipper), 2 1/2"	3" (dipper), 2 1/2"	3" (dipper), 2 1/2" (1 1/4" extend)
Bucket Sizes Available	9, 12, 15, 18	9, 12, 15, 18, 24	9, 12, 15, 18, 25	9, 12, 15, 18, 24
3 Point Hitch	Cat I (PT300)	Cat I (PT300)/Cat II (PT322)	Cat I (PT300)/Cat II (PT322)	Cat I (PT300)/Cat II (PT322)

AUTHORIZED DEALER:

WALLENSTEIN

Manufactured by EMB MFG Inc. 4144 Boomer Line, St. Clements, ON N0B 2M0
 Toll Free: 1-877-695-9283 Tel: (519) 699-9283 Fax: (519) 699-4146
 Email: sales@embmfg.com www.embmfg.com

PART# Z86323R1
 ©2007 EMB MFG Inc.
 All rights reserved.

DNR

Four Wheel Drive, Diesel Utility Tractor With Front End Loader and
Backhoe Attachment

PRICING SHEET

ITEM NO.	QUANTITY	DESCRIPTION	UNIT PRICE	AMOUNT
1	1	Four Wheel Drive, Diesel Utility Tractor With Front End Loader	36,113. ⁰⁶	36,113. ⁰⁶
2	1	Backhoe Attachment	7,464. ⁹⁹	7,464. ⁹⁹
			TOTAL COST	\$ 43,578. ⁰⁵

Note: Delivery must be made within thirty (30) days of purchase order award.

Tractor with Front End Loader and Backhoe to be delivered to the following location:

Headquarters
Shenandoah Wildlife Management Area – Pendleton County
Brandywine, WV 26802
Contact Chuck Waggy (304-358-7912) for delivery information

DNR

Four Wheel Drive, Diesel Utility Tractor With Front End Loader and
Backhoe Attachment

MANUFACTURER'S LIST

Please complete the below information concerning the brand(s) of equipment being bid in relation to this project. If bidding "or equal" brands, please attach manufacturer's literature documenting that it meets the mandatory requirements stated in the specifications. Vendors should note the areas of the provided manufacturer's literature that adheres to the mandatory requirements outlined in the Request for Quotation.

ITEM NO.	EQUIPMENT	MANUFACTURER	MODEL
1	Four Wheel Drive, Diesel Utility Tractor With Front End Loader	John Deere John Deere	5075M 553
2	Backhoe Attachment	Wallenstein	GX920

VENDOR PREFERENCE CERTIFICATE

Certification and application* is hereby made for Preference in accordance with West Virginia Code, §5A-3-37. (Does not apply to construction contracts). West Virginia Code, §5A-3-37, provides an opportunity for qualifying vendors to request (at the time of bid) preference for their residency status. Such preference is an evaluation method only and will be applied only to the cost bid in accordance with the West Virginia Code. This certificate for application is to be used to request such preference. The Purchasing Division will make the determination of the Resident Vendor Preference, if applicable.

- 1. Application is made for 2.5% resident vendor preference for the reason checked: Bidder is an individual resident vendor and has resided continuously in West Virginia for four (4) years immediately preceding the date of this certification; or, Bidder is a partnership, association or corporation resident vendor and has maintained its headquarters or principal place of business continuously in West Virginia for four (4) years immediately preceding the date of this certification; or 80% of the ownership interest of Bidder is held by another individual, partnership, association or corporation resident vendor who has maintained its headquarters or principal place of business continuously in West Virginia for four (4) years immediately preceding the date of this certification; or, Bidder is a nonresident vendor which has an affiliate or subsidiary which employs a minimum of one hundred state residents and which has maintained its headquarters or principal place of business within West Virginia continuously for the four (4) years immediately preceding the date of this certification; or,
2. Application is made for 2.5% resident vendor preference for the reason checked: Bidder is a resident vendor who certifies that, during the life of the contract, on average at least 75% of the employees working on the project being bid are residents of West Virginia who have resided in the state continuously for the two years immediately preceding submission of this bid; or,
3. Application is made for 2.5% resident vendor preference for the reason checked: Bidder is a nonresident vendor employing a minimum of one hundred state residents or is a nonresident vendor with an affiliate or subsidiary which maintains its headquarters or principal place of business within West Virginia employing a minimum of one hundred state residents who certifies that, during the life of the contract, on average at least 75% of the employees or Bidder's affiliate's or subsidiary's employees are residents of West Virginia who have resided in the state continuously for the two years immediately preceding submission of this bid; or,
4. Application is made for 5% resident vendor preference for the reason checked: Bidder meets either the requirement of both subdivisions (1) and (2) or subdivision (1) and (3) as stated above; or,
5. Application is made for 3.5% resident vendor preference who is a veteran for the reason checked: Bidder is an individual resident vendor who is a veteran of the United States armed forces, the reserves or the National Guard and has resided in West Virginia continuously for the four years immediately preceding the date on which the bid is submitted; or,
6. Application is made for 3.5% resident vendor preference who is a veteran for the reason checked: Bidder is a resident vendor who is a veteran of the United States armed forces, the reserves or the National Guard, if, for purposes of producing or distributing the commodities or completing the project which is the subject of the vendor's bid and continuously over the entire term of the project, on average at least seventy-five percent of the vendor's employees are residents of West Virginia who have resided in the state continuously for the two immediately preceding years.

Bidder understands if the Secretary of Revenue determines that a Bidder receiving preference has failed to continue to meet the requirements for such preference, the Secretary may order the Director of Purchasing to: (a) reject the bid; or (b) assess a penalty against such Bidder in an amount not to exceed 5% of the bid amount and that such penalty will be paid to the contracting agency or deducted from any unpaid balance on the contract or purchase order.

By submission of this certificate, Bidder agrees to disclose any reasonably requested information to the Purchasing Division and authorizes the Department of Revenue to disclose to the Director of Purchasing appropriate information verifying that Bidder has paid the required business taxes, provided that such information does not contain the amounts of taxes paid nor any other information deemed by the Tax Commissioner to be confidential.

Under penalty of law for false swearing (West Virginia Code, §61-5-3), Bidder hereby certifies that this certificate is true and accurate in all respects; and that if a contract is issued to Bidder and if anything contained within this certificate changes during the term of the contract, Bidder will notify the Purchasing Division in writing immediately.

Bidder: Middletown Tractor Sales
Date: 28 March 2011

Signed: [Signature]
Title: Sales Consultant

*Check any combination of preference consideration(s) indicated above, which you are entitled to receive.

RFQ No. DNR211136

STATE OF WEST VIRGINIA
Purchasing Division

PURCHASING AFFIDAVIT

West Virginia Code §5A-3-10a states: No contract or renewal of any contract may be awarded by the state or any of its political subdivisions to any vendor or prospective vendor when the vendor or prospective vendor or a related party to the vendor or prospective vendor is a debtor and the debt owed is an amount greater than one thousand dollars in the aggregate.

DEFINITIONS:

"Debt" means any assessment, premium, penalty, fine, tax or other amount of money owed to the state or any of its political subdivisions because of a judgment, fine, permit violation, license assessment, defaulted workers' compensation premium, penalty or other assessment presently delinquent or due and required to be paid to the state or any of its political subdivisions, including any interest or additional penalties accrued thereon.

"Debtor" means any individual, corporation, partnership, association, limited liability company or any other form or business association owing a debt to the state or any of its political subdivisions. "Political subdivision" means any county commission; municipality; county board of education; any instrumentality established by a county or municipality; any separate corporation or instrumentality established by one or more counties or municipalities, as permitted by law; or any public body charged by law with the performance of a government function or whose jurisdiction is coextensive with one or more counties or municipalities. "Related party" means a party, whether an individual, corporation, partnership, association, limited liability company or any other form or business association or other entity whatsoever, related to any vendor by blood, marriage, ownership or contract through which the party has a relationship of ownership or other interest with the vendor so that the party will actually or by effect receive or control a portion of the benefit, profit or other consideration from performance of a vendor contract with the party receiving an amount that meets or exceeds five percent of the total contract amount.

EXCEPTION: The prohibition of this section does not apply where a vendor has contested any tax administered pursuant to chapter eleven of this code, workers' compensation premium, permit fee or environmental fee or assessment and the matter has not become final or where the vendor has entered into a payment plan or agreement and the vendor is not in default of any of the provisions of such plan or agreement.

Under penalty of law for false swearing (*West Virginia Code §61-5-3*), it is hereby certified that the vendor affirms and acknowledges the information in this affidavit and is in compliance with the requirements as stated.

WITNESS THE FOLLOWING SIGNATURE

Vendor's Name: Middletown Tractor Sales

Authorized Signature: [Signature] Date: 28 March 2011

State of WV

County of Taylor, to-wit:

Taken, subscribed, and sworn to before me this 28 day of MARCH, 2011.

My Commission expires 09-30, 2019.

AFFIX SEAL HERE

NOTARY PUBLIC [Signature: Beatrice K. Stevens]

