



State of West Virginia  
 Department of Administration  
 Purchasing Division  
 2019 Washington Street East  
 Post Office Box 50130  
 Charleston, WV 25305-0130

# Request for Quotation

RFO NUMBER  
**DEP15165**

PAGE  
**1**

ADDRESS CORRESPONDENCE TO ATTENTION OF  
**CHUCK BOWMAN**  
**304-558-2157**

**\*B19160306**      **304-622-2400**  
**PRO CONTRACTING INC**  
**PO BOX 2442**  
**CLARKSBURG WV 26301**

VENDOR

SHIP TO

**ENVIRONMENTAL PROTECTION**  
**DEPT. OF**  
**OFFICE OF SPECIAL RECLAMATION**  
**105 S. RAILROAD STREET**  
**PHILIPPI, WV**  
**26416-9998**      **304-457-3219**

DATE PRINTED <b>08/25/2010</b>	TERMS OF SALE	SHIP VIA	F.O.B.	FREIGHT TERMS
BID OPENING DATE: <b>10/21/2010</b> <b>BID OPENING TIME 01:30PM</b>				

LINE	QUANTITY	UOP	CAT. NO.	ITEM NUMBER	UNIT PRICE	AMOUNT
0001	1	JB		962-73		<i>658,805<sup>00</sup></i>
<p><b>RECLAMATION: RESTORATION OF LAND</b></p> <p>THE WEST VIRGINIA PURCHASING DIVISION, ON BEHALF OF THE AGENCY, THE WEST VIRGINIA DEPARTMENT OF ENVIRONMENTAL PROTECTION, IS SOLICITING BIDS FROM QUALIFIED CONTRACTORS FOR A CONTRACT TO PROVIDE ALL LABOR AND MATERIALS TO PERFORM RECLAMATION ON THE MINING OPERATION OF THE MASTELLER COAL COMPANY, NOW UNDER REVOKED PERMIT NUMBER(S) P-741.</p> <p>THIS SITE CONSISTS OF APPROXIMATELY 29.0 ACRES AND IS LOCATED NEAR PIEDMONT, WV IN MINERAL COUNTY.</p> <p>THE RECLAMATION SHALL BE PERFORMED UNDER THE GUIDANCE AND GENERAL SUPERVISION OF THE AGENT ASSIGNED TO THE PROJECT FOR THE STATE OF WEST VIRGINIA, DEPARTMENT OF ENVIRONMENTAL PROTECTION.</p> <p>A MANDATORY ON-SITE PREBID CONFERENCE SHALL BE HELD ON 09/30/10 AT 10:00AM. FAILURE TO ATTEND THE PREBID CONFERENCE WILL RESULT IN BID DISQUALIFICATION. NO ONE PERSON MAY REPRESENT MORE THAN ONE BIDDER.</p> <p>AN ATTENDANCE SHEET WILL BE MADE AVAILABLE FOR ALL POTENTIAL BIDDERS TO COMPLETE. THIS WILL SERVE AS THE OFFICIAL DOCUMENT VERIFYING ATTENDANCE AT THE MANDATORY PRE-BID. FAILURE TO PROVIDE YOUR COMPANY AND REPRESENTATIVE NAME ON THE ATTENDANCE SHEET WILL RESULT IN DISQUALIFICATION OF THE BID. THE STATE WILL NOT ACCEPT ANY OTHER DOCUMENTATION TO VERIFY ATTENDANCE. THE BIDDER I</p>						

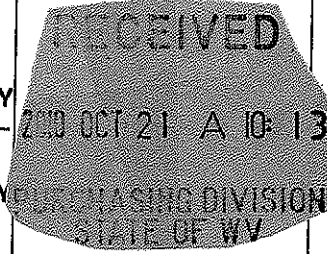

SEE REVERSE SIDE FOR TERMS AND CONDITIONS

SIGNATURE: *[Signature]*      TELEPHONE: **304-622-2400**      DATE: **10-20-10**

TITLE: **Vice President**      FEIN: **26-3348227**      ADDRESS CHANGES TO BE NOTED ABOVE

WHEN RESPONDING TO RFQ, INSERT NAME AND ADDRESS IN SPACE ABOVE LABELED 'VENDOR'

## GENERAL TERMS & CONDITIONS REQUEST FOR QUOTATION (RFQ) AND REQUEST FOR PROPOSAL (RFP)

1. Awards will be made in the best interest of the State of West Virginia.
  2. The State may accept or reject in part, or in whole, any bid.
  3. Prior to any award, the apparent successful vendor must be properly registered with the Purchasing Division and have paid the required \$125 fee.
  4. All services performed or goods delivered under State Purchase Order/Contracts are to be continued for the term of the Purchase Order/Contracts, contingent upon funds being appropriated by the Legislature or otherwise being made available. In the event funds are not appropriated or otherwise available for these services or goods this Purchase Order/Contract becomes void and of no effect after June 30.
  5. Payment may only be made after the delivery and acceptance of goods or services.
  6. Interest may be paid for late payment in accordance with the *West Virginia Code*.
  7. Vendor preference will be granted upon written request in accordance with the *West Virginia Code*.
  8. The State of West Virginia is exempt from federal and state taxes and will not pay or reimburse such taxes.
  9. The Director of Purchasing may cancel any Purchase Order/Contract upon 30 days written notice to the seller.
  10. The laws of the State of West Virginia and the *Legislative Rules* of the Purchasing Division shall govern the purchasing process.
  11. Any reference to automatic renewal is hereby deleted. The Contract may be renewed only upon mutual written agreement of the parties.
  12. **BANKRUPTCY:** In the event the vendor/contractor files for bankruptcy protection, the State may deem this contract null and void, and terminate such contract without further order.
  13. **HIPAA BUSINESS ASSOCIATE ADDENDUM:** The West Virginia State Government HIPAA Business Associate Addendum (BAA), approved by the Attorney General, is available online at [www.state.wv.us/admin/purchase/vrc/hipaa.htm](http://www.state.wv.us/admin/purchase/vrc/hipaa.htm) and is hereby made part of the agreement. Provided that the Agency meets the definition of a Cover Entity (45 CFR §160.103) and will be disclosing Protected Health Information (45 CFR §160.103) to the vendor.
  14. **CONFIDENTIALITY:** The vendor agrees that he or she will not disclose to anyone, directly or indirectly, any such personally identifiable information or other confidential information gained from the agency, unless the individual who is the subject of the information consents to the disclosure in writing or the disclosure is made pursuant to the agency's policies, procedures, and rules. Vendor further agrees to comply with the Confidentiality Policies and Information Security Accountability Requirements, set forth in <http://www.state.wv.us/admin/purchase/privacy/noticeConfidentiality.pdf>.
  15. **LICENSING:** Vendors must be licensed and in good standing in accordance with any and all state and local laws and requirements by any state or local agency of West Virginia, including, but not limited to, the West Virginia Secretary of State's Office, the West Virginia Tax Department, and the West Virginia Insurance Commission. The vendor must provide all necessary releases to obtain information to enable the director or spending unit to verify that the vendor is licensed and in good standing with the above entities.
  16. **ANTITRUST:** In submitting a bid to any agency for the State of West Virginia, the bidder offers and agrees that if the bid is accepted the bidder will convey, sell, assign or transfer to the State of West Virginia all rights, title and interest in and to all causes of action it may now or hereafter acquire under the antitrust laws of the United States and the State of West Virginia for price fixing and/or unreasonable restraints of trade relating to the particular commodities or services purchased or acquired by the State of West Virginia. Such assignment shall be made and become effective at the time the purchasing agency tenders the initial payment to the bidder.
- I certify that this bid is made without prior understanding, agreement, or connection with any corporation, firm, limited liability company, partnership, or person or entity submitting a bid for the same material, supplies, equipment or services and is in all respects fair and without collusion or fraud. I further certify that I am authorized to sign this certification on behalf of the bidder or this bid.

### INSTRUCTIONS TO BIDDERS

1. Use the quotation forms provided by the Purchasing Division. Complete all sections of the quotation form.
2. Items offered must be in compliance with the specifications. Any deviation from the specifications must be clearly indicated by the bidder. Alternates offered by the bidder as **EQUAL** to the specifications must be clearly defined. A bidder offering an alternate should attach complete specifications and literature to the bid. The Purchasing Division may waive minor deviations to specifications.
3. Unit prices shall prevail in case of discrepancy. All quotations are considered F.O.B. destination unless alternate shipping terms are clearly identified in the quotation.
4. All quotations must be delivered by the bidder to the office listed below prior to the date and time of the bid opening. Failure of the bidder to deliver the quotations on time will result in bid disqualifications: Department of Administration, Purchasing Division, 2019 Washington Street East, P.O. Box 50130, Charleston, WV 25305-0130
5. Communication during the solicitation, bid, evaluation or award periods, except through the Purchasing Division, is strictly prohibited (W.Va. C.S.R. §148-1-6.6).



State of West Virginia  
 Department of Administration  
 Purchasing Division  
 2019 Washington Street East  
 Post Office Box 50130  
 Charleston, WV 25305-0130

# Request for Quotation

RFQ NUMBER
DEP15165

PAGE
3

ADDRESS CORRESPONDENCE TO ATTENTION OF
CHUCK BOWMAN 304-558-2157

VENDOR

\*B19160306      304-622-2400  
 PRO CONTRACTING INC  
 PO BOX 2442  
  
 CLARKSBURG WV 26301

SHIP TO

ENVIRONMENTAL PROTECTION  
 DEPT. OF  
 OFFICE OF SPECIAL RECLAMATION  
 105 S. RAILROAD STREET  
 PHILIPPI, WV  
 26416-9998      304-457-3219

DATE PRINTED	TERMS OF SALE	SHIP VIA	F.O.B.	FREIGHT TERMS
08/25/2010				
BID OPENING DATE: 10/21/2010		BID OPENING TIME 01:30PM		

LINE	QUANTITY	UOP	CAT NO	ITEM NUMBER	UNIT PRICE	AMOUNT
				CHAPTER 21 OF THE WEST VIRGINIA CODE. FAILURE TO SUBMIT THE SIGNED PURCHASING AFFIDAVIT WITH THE BID SHALL RESULT IN DISQUALIFICATION OF SUCH BID.		
				NOTICE TO PROCEED: THIS CONTRACT IS TO BE PERFORMED WITHIN 365 CALENDAR DAYS AFTER THE NOTICE TO PROCEED IS RECEIVED. UNLESS OTHERWISE SPECIFIED, THE FULLY EXECUTED PURCHASE ORDER WILL BE CONSIDERED NOTICE TO PROCEED.		
				CANCELLATION: THE DIRECTOR OF PURCHASING RESERVES THE RIGHT TO CANCEL THIS CONTRACT IMMEDIATELY UPON WRITTEN NOTICE TO THE VENDOR IF THE MATERIALS OR WORKMANSHIP SUPPLIED ARE OF AN INFERIOR QUALITY OR DO NOT CONFORM WITH THE SPECIFICATIONS OF THE THE BID AND CONTRACT HERE IN.		
				WAGE RATES: THE CONTRACTOR OR SUBCONTRACTOR SHALL PAY THE HIGHER OF THE U.S. DEPARTMENT OF LABOR MINIMUM WAGE RATES AS ESTABLISHED FOR MINERAL COUNTY, PURSUANT TO WEST VIRGINIA CODE 21-5A, ET, SEQ. (PREVAILING WAGE RATES APPLY TO THIS PROJECT)		
				ARBITRATION: ANY REFERENCES MADE TO ARBITRATION OR INTEREST FOR PAYMENTS DUE (EXCEPT FOR ANY INTEREST REQUIRED BY STATE LAW) CONTAINED IN THIS CONTRACT OR IN ANY AMERICAN INSTITUTE OF ARCHITECTS DOCUMENTS PERTAINING TO THIS CONTRACT ARE HEREBY DELETED.		
				WORKERS' COMPENSATION: VENDOR IS REQUIRED TO PROVIDE A CERTIFICATE FROM WORKERS' COMPENSATION IF SUCCESSFUL.		
				ALL OF THE ITEMS CHECKED BELOW WILL BE A REQUIREMENT OF THIS CONTRACT:		
				(XX) INSURANCE: SUCCESSFUL VENDOR SHALL FURNISH PROOF		

SEE REVERSE SIDE FOR TERMS AND CONDITIONS

SIGNATURE	TELEPHONE	DATE
-----------	-----------	------

TITLE	FEIN	ADDRESS CHANGES TO BE NOTED ABOVE
-------	------	-----------------------------------

WHEN RESPONDING TO RFQ, INSERT NAME AND ADDRESS IN SPACE ABOVE LABELED 'VENDOR'



State of West Virginia  
 Department of Administration  
 Purchasing Division  
 2019 Washington Street East  
 Post Office Box 50130  
 Charleston, WV 25305-0130

# Request for Quotation

RFQ NUMBER
DEP15165

PAGE
4

ADDRESS CORRESPONDENCE TO ATTENTION OF
CHUCK BOWMAN 304-558-2157

VENDOR

\*B19160306      304-622-2400  
 PRO CONTRACTING INC  
 PO BOX 2442  
 CLARKSBURG WV 26301

SHIP TO

ENVIRONMENTAL PROTECTION  
 DEPT. OF  
 OFFICE OF SPECIAL RECLAMATION  
 105 S. RAILROAD STREET  
 PHILIPPI, WV  
 26416-9998      304-457-3219

DATE PRINTED	TERMS OF SALE	SHIP VIA	FOB	FREIGHT TERMS
08/25/2010				
BID OPENING DATE: 10/21/2010		BID OPENING TIME 01:30PM		

LINE	QUANTITY	UOP	CAT NO	ITEM NUMBER	UNIT PRICE	AMOUNT
				OF COMMERCIAL GENERAL LIABILITY INSURANCE PRIOR TO ISSUANCE OF CONTRACT. UNLESS OTHERWISE SPECIFIED IN THE BID DOCUMENTS, THE MINIMUM AMOUNT OF INSURANCE COVERAGE REQUIRED IS \$250,000.		
				( ) BUILDERS RISK INSURANCE: SUCCESSFUL VENDOR SHALL FURNISH PROOF OF BUILDERS RISK - ALL RISK INSURANCE IN AN AMOUNT EQUAL TO 100% OF THE AMOUNT OF THE CONTRACT.		
				(XX) BONDS: FIVE PERCENT (5%) OF THE TOTAL AMOUNT OF THE BID PAYABLE TO THE STATE OF WEST VIRGINIA, SHALL BE SUBMITTED WITH EACH BID AS A BID BOND. THE SUCCESSFUL BIDDER SHALL ALSO FURNISH A PERFORMANCE BOND AND LABOR/MATERIAL BOND FOR 100% OF THE AMOUNT OF THE CONTRACT. BONDS MAY BE PROVIDED IN THE FORM OF A CERTIFIED CHECK, IRREVOCABLE LETTER OF CREDIT, OR BOND FURNISHED BY A SOLVENT SURETY COMPANY AUTHORIZED TO DO BUSINESS IN THE STATE OF WEST VIRGINIA. A LETTER OF CREDIT SUBMITTED IN LIEU OF A BOND WILL ONLY BE ALLOWED FOR PROJECTS UNDER \$100,000. PERSONAL OR BUSINESS CHECKS ARE NOT ACCEPTABLE IN LIEU OF THE 5% BID BOND, PERFORMANCE BOND, OR LABOR AND MATERIAL BOND.		
				( ) MAINTENANCE BOND: A TWO (2) YEAR MAINTENANCE BOND COVERING THE ROOFING SYSTEM WILL BE A REQUIREMENT OF THE SUCCESSFUL VENDOR.		
				REV. 11/00		
				CONTRACTORS LICENSE		
				WEST VIRGINIA STATE CODE 21-11-2 REQUIRES THAT ALL PERSONS DESIRING TO PERFORM CONTRACTING WORK IN THIS STATE MUST BE LICENSED. THE WEST VIRGINIA CONTRACTORS LICENSING BOARD IS EMPOWERED TO ISSUE THE CONTRACTORS		

SIGNATURE			SEE REVERSE SIDE FOR TERMS AND CONDITIONS		
TITLE		FEIN	TELEPHONE	DATE	
ADDRESS CHANGES TO BE NOTED ABOVE					

WHEN RESPONDING TO RFQ, INSERT NAME AND ADDRESS IN SPACE ABOVE LABELED 'VENDOR'



State of West Virginia  
 Department of Administration  
 Purchasing Division  
 2019 Washington Street East  
 Post Office Box 50130  
 Charleston, WV 25305-0130

# Request for Quotation

RFQ NUMBER
DEP15165

PAGE
5

ADDRESS CORRESPONDENCE TO ATTENTION OF
CHUCK BOWMAN 304-558-2157

\*B19160306      304-622-2400  
 PRO CONTRACTING INC  
 PO BOX 2442

CLARKSBURG WV 26301

ENVIRONMENTAL PROTECTION  
 DEPT. OF  
 OFFICE OF SPECIAL RECLAMATION  
 105 S. RAILROAD STREET  
 PHILIPPI, WV  
 26416-9998      304-457-3219

DATE PRINTED	TERMS OF SALE	SHIP VIA	F.O.B.	FREIGHT TERMS
08/25/2010				

BID OPENING DATE: 10/21/2010      BID OPENING TIME 01:30PM

LINE	QUANTITY	UOP	CAT NO.	ITEM NUMBER	UNIT PRICE	AMOUNT
				<p>LICENSE. APPLICATIONS FOR A CONTRACTORS LICENSE MAY BE MADE BY CONTACTING THE WEST VIRGINIA DIVISION OF LABOR CAPITOL COMPLEX, BUILDING 3, ROOM 319, CHARLESTON, WV 25305. TELEPHONE: (304) 558-7890.</p> <p>WEST VIRGINIA STATE CODE 21-11-11 REQUIRES ANY PROSPECTIVE BIDDER TO INCLUDE THE CONTRACTORS LICENSE NUMBER ON THEIR BID.</p> <p>BIDDER TO COMPLETE:            CONTRACTORS NAME: ..... <i>Pro Contracting, Inc.</i> .....            CONTRACTORS LICENSE NO.: ..... <i>WV 044670</i> .....</p> <p>THE SUCCESSFUL BIDDER WILL BE REQUIRED TO FURNISH A COPY OF THEIR CONTRACTORS LICENSE PRIOR TO ISSUANCE OF A PURCHASE ORDER/CONTRACT.</p> <p>APPLICABLE LAW</p> <p>THE WEST VIRGINIA STATE CODE, PURCHASING DIVISION RULES AND REGULATIONS, AND THE INFORMATION PROVIDED IN THE "REQUEST FOR QUOTATION" ISSUED BY THE PURCHASING DIVISION IS THE SOLE AUTHORITY GOVERNING THIS PROCUREMENT.</p> <p>ANY INFORMATION PROVIDED IN SPECIFICATION MANUALS, OR ANY OTHER SOURCE, VERBAL OR WRITTEN, WHICH CONTRADICTS OR ALTERS THE INFORMATION PROVIDED FROM THE SOURCES AS DESCRIBED IN THE ABOVE PARAGRAPH IS VOID AND OF NO EFFECT.</p> <p>BANKRUPTCY: IN THE EVENT THE VENDOR/CONTRACTOR FILES FOR BANKRUPTCY PROTECTION, THE STATE MAY DEEM THIS CONTRACT NULL AND VOID AND TERMINATE SUCH CONTRACT WITHOUT FURTHER ORDER.</p>		

SEE REVERSE SIDE FOR TERMS AND CONDITIONS

SIGNATURE <i>[Signature]</i>	TELEPHONE 304-622-2400	DATE 10-20-10
TITLE Vice President	FEIN 26-3348227	ADDRESS CHANGES TO BE NOTED ABOVE

WHEN RESPONDING TO RFQ, INSERT NAME AND ADDRESS IN SPACE ABOVE LABELED 'VENDOR'



State of West Virginia  
 Department of Administration  
 Purchasing Division  
 2019 Washington Street East  
 Post Office Box 50130  
 Charleston, WV 25305-0130

# Request for Quotation

RFQ NUMBER
DEP15165

PAGE
6

ADDRESS CORRESPONDENCE TO ATTENTION OF
CHUCK BOWMAN 304-558-2157

VENDOR

\*B19160306      304-622-2400  
 PRO CONTRACTING INC  
 PO BOX 2442  
 CLARKSBURG WV 26301

SHIP TO

ENVIRONMENTAL PROTECTION  
 DEPT. OF  
 OFFICE OF SPECIAL RECLAMATION  
 105 S. RAILROAD STREET  
 PHILIPPI, WV  
 26416-9998      304-457-3219

DATE PRINTED	TERMS OF SALE	SHIP VIA	F.O.B.	FREIGHT TERMS
08/25/2010				
BID OPENING DATE: 10/21/2010		BID OPENING TIME 01:30PM		

LINE	QUANTITY	UOP	CAT NO.	ITEM NUMBER	UNIT PRICE	AMOUNT
<p>PREFERENCE FOR USE OF DOMESTIC STEEL PRODUCTS</p> <p>1. EXCEPT WHEN AUTHORIZED BY THE DIRECTOR OF THE PURCHASING DIVISION PURSUANT TO SUBSECTION 2 BELOW, NO CONTRACTOR MAY USE OR SUPPLY STEEL PRODUCTS FOR A STATE CONTRACT PROJECT OTHER THAN THOSE STEEL PRODUCTS MADE IN THE UNITED STATES. AS USED USED IN THIS CONTRACT,</p> <p>A. "STATE CONTRACT PROJECT" MEANS ANY ERECTION OR CONSTRUCTION OF, OR ANY ADDITION TO, ALTERATIO OF OR OTHER IMPROVEMENT TO ANY BUILDING OR STRUCTURE, INCLUDING, BUT NOT LIMITED TO, ROADS OR HIGHWAYS, OR THE INSTALLATION OF ANY HEATING OR COOLING OR VENTILATING PLANTS OR OTHER EQUIPMENT, OR THE SUPPLY OF AND MATERIALS FOR SUCH PROJECTS, PURSUANT TO A CONTRACT WITH THE STATE OF WEST VIRGINIA FOR WHICH BIDS WERE SOLICITED ON OR AFTER JUNE 6, 2001.</p> <p>B. "STEEL PRODUCTS" MEANS PRODUCTS ROLLED, FORMED, SHAPED, DRAWN, EXTRUDED, FORGED, CAST, FABRICATED OR OTHERWISE SIMILARLY PROCESSED, O PROCESSED BY A COMBINATION OF TWO OR MORE OF SUCH OPERATIONS, FROM STEEL MADE BY THE OPEN HEARTH, BASIC OXYGEN, ELECTRIC FURNACE, BESSEMER OR OTHER STEEL MAKING PROCESS.</p> <p>C. "UNITED STATES" MEANS THE UNITED STATES OF AMERICA AND INCLUDES ALL TERRITORY, CONTINENTAL OR INSULAR, SUBJECT TO THE JURISDICTION OF THE UNITED STATES.</p> <p>2. THE DIRECTOR OF THE PURCHASING DIVISION MAY, IN WRITING, AUTHORIZE THE USE OF FOREIGN STEEL</p>						

SEE REVERSE SIDE FOR TERMS AND CONDITIONS

SIGNATURE	TELEPHONE	DATE
TITLE	FEIN	

ADDRESS CHANGES TO BE NOTED ABOVE

WHEN RESPONDING TO RFQ, INSERT NAME AND ADDRESS IN SPACE ABOVE LABELED 'VENDOR'



State of West Virginia  
 Department of Administration  
 Purchasing Division  
 2019 Washington Street East  
 Post Office Box 50130  
 Charleston, WV 25305-0130

# Request for Quotation

RFQ NUMBER
DEP15165

PAGE
7

ADDRESS CORRESPONDENCE TO ATTENTION OF
CHUCK BOWMAN 304-558-2157

VENDOR

\*B19160306      304-622-2400  
 PRO CONTRACTING INC  
 PO BOX 2442  
  
 CLARKSBURG WV 26301

OFFICE

ENVIRONMENTAL PROTECTION  
 DEPT. OF  
 OFFICE OF SPECIAL RECLAMATION  
 105 S. RAILROAD STREET  
 PHILIPPI, WV  
 26416-9998      304-457-3219

DATE PRINTED	TERMS OF SALE	SHIP VIA	FOB	FREIGHT TERMS
08/25/2010				

BID OPENING DATE: **10/21/2010**      BID OPENING TIME **01:30PM**

LINE	QUANTITY	UOP	CAT NO	ITEM NUMBER	UNIT PRICE	AMOUNT
<p><b>PRODUCTS IF:</b></p> <p>A. THE COST FOR EACH CONTRACT ITEM USED DOES NOT EXCEED ONE TENTH OF ONE PERCENT (.1%) OF THE TOTAL CONTRACT COST OR TWO THOUSAND FIVE HUNDRED DOLLARS (2,500.00), WHICHEVER IS GREATER. FOR THE PURPOSES OF THIS SECTION, THE COST IS THE VALUE OF THE STEEL PRODUCT AS DELIVERED TO THE PROJECT OR,</p> <p>B. THE DIRECTOR OF THE PURCHASING DIVISION DETERMINES THAT SPECIFIED STEEL MATERIALS ARE NOT PRODUCED IN THE UNITED STATES IN SUFFICIENT QUANTITY OR OTHERWISE ARE NOT REASONABLY AVAILABLE TO MEET CONTRACT REQUIREMENTS.</p> <p>3. A CONTRACTOR WHO USES STEEL PRODUCTS IN VIOLATION OF THIS SECTION MAY BE SUBJECT TO CIVIL PENALTIES PURSUANT TO WV CODE SECTION 5A-3-56.</p> <p>REV. 10/01/01</p> <p>EXHIBIT 7</p> <p>DOMESTIC ALUMINUM, GLASS &amp; STEEL IN PUBLIC WORKS PROJECTS</p> <p>IN ACCORDANCE WITH WEST VIRGINIA CODE 5-19-1 ET., SEQ., EVERY CONTRACT FOR CONSTRUCTION, RECONSTRUCTION, ALTERATION, REPAIR, IMPROVEMENT OR MAINTENANCE OF PUBLIC WORKS, WHERE THE COST IS MORE THAN \$50,000 AND, IN THE CASE OF STEEL ONLY, WHERE THE COST OF STEEL IS MORE THAN \$50,000 OR WHERE MORE THAN 10,000 POUNDS OF STEEL ARE REQUIRED, THE STATE WILL ACCEPT ONLY ALUMINUM GLASS, OR STEEL PRODUCTS PRODUCED IN THE UNITED STATES</p>						

SEE REVERSE SIDE FOR TERMS AND CONDITIONS

SIGNATURE	TELEPHONE	DATE
-----------	-----------	------

TITLE	FEIN	ADDRESS CHANGES TO BE NOTED ABOVE
-------	------	-----------------------------------

WHEN RESPONDING TO RFQ, INSERT NAME AND ADDRESS IN SPACE ABOVE LABELED 'VENDOR'



State of West Virginia  
 Department of Administration  
 Purchasing Division  
 2019 Washington Street East  
 Post Office Box 50130  
 Charleston, WV 25305-0130

# Request for Quotation

RFQ NUMBER  
 DEP15165

PAGE  
 8

ADDRESS CORRESPONDENCE TO ATTENTION OF  
 CHUCK BOWMAN  
 304-558-2157

\*B19160306 304-622-2400  
 PRO CONTRACTING INC  
 PO BOX 2442  
 CLARKSBURG WV 26301

ENVIRONMENTAL PROTECTION  
 DEPT. OF  
 OFFICE OF SPECIAL RECLAMATION  
 105 S. RAILROAD STREET  
 PHILIPPI, WV  
 26416-9998 304-457-3219

DATE PRINTED 08/25/2010	TERMS OF SALE	SHIP VIA	FOB	FREIGHT TERMS
----------------------------	---------------	----------	-----	---------------

BID OPENING DATE: 10/21/2010 BID OPENING TIME 01:30PM

LINE	QUANTITY	UOP	CAT NO	ITEM NUMBER	UNIT PRICE	AMOUNT
<p>IN ADDITION, ITEMS OF MACHINERY OR EQUIPMENT PURCHASED FOR USE AT THE SITE OF PUBLIC WORKS SHALL BE MADE OF DOMESTIC ALUMINUM, GLASS OR STEEL, UNLESS THE COST OF THE PRODUCT IS LESS THAN \$50,000 OR LESS THAN 10,000 POUNDS OF STEEL ARE USED IN PUBLIC WORKS PROJECTS.</p> <p>FOREIGN MADE ALUMINUM, GLASS OR STEEL PRODUCTS MAY BE ACCEPTED ONLY IF THE COST OF DOMESTIC PRODUCTS IS FOUND TO BE UNREASONABLE. SUCH COST IS UNREASONABLE IF IT IS 20% OR MORE HIGHER THAN THE BID PRICE FOR FOREIGN MADE PRODUCTS. IF THE DOMESTIC ALUMINUM, GLASS OR STEEL PRODUCTS TO BE SUPPLIED OR PRODUCED IN A "SUBSTANTIAL LABOR SURPLUS AREA", AS DEFINED BY THE UNITED STATES DEPARTMENT OF LABOR, FOREIGN PRODUCTS MAY BE SUPPLIED ONLY IF DOMESTIC PRODUCTS ARE 30% OR MORE HIGHER IN PRICE THAN THE FOREIGN MADE PRODUCTS.</p> <p>IF, PRIOR TO THE AWARD OF A CONTRACT UNDER THE ABOVE PROVISIONS, THE SPENDING OFFICER OF THE SPENDING UNIT DETERMINES THAT THERE EXISTS A BID FOR LIKE FOREIGN ALUMINUM, GLASS OR STEEL THAT IS REASONABLE AND LOWER THAN THE LOWEST BID DOMESTIC PRODUCTS, THE SPENDING OFFICE MAY REQUEST, IN WRITING, A REEVALUATION AND REDUCTION IN THE LOWEST BID FOR SUCH DOMESTIC PRODUCTS ALL VENDORS MUST INDICATE IN THEIR BID IF THEY ARE SUPPLYING FOREIGN ALUMINUM, GLASS OR STEEL.</p> <p>REV. 3/88</p> <p>EXHIBIT 9</p> <p>NOTICE FOR ISSUANCE &amp; ACKNOWLEDGEMENT OF CONSTRUCTION PROJECT ADDENDA</p> <p>THE ARCHITECT/ENGINEER AND/OR AGENCY SHALL BE REQUIRED TO ABIDE BY THE FOLLOWING SCHEDULE IN ISSUING</p>						

SEE REVERSE SIDE FOR TERMS AND CONDITIONS

SIGNATURE	TELEPHONE	DATE
TITLE	FEIN	ADDRESS CHANGES TO BE NOTED ABOVE

WHEN RESPONDING TO RFQ, INSERT NAME AND ADDRESS IN SPACE ABOVE LABELED 'VENDOR'





State of West Virginia  
 Department of Administration  
 Purchasing Division  
 2019 Washington Street East  
 Post Office Box 50130  
 Charleston, WV 25305-0130

# Request for Quotation

RFQ NUMBER
DEP15165

PAGE
9

ADDRESS CORRESPONDENCE TO ATTENTION OF
CHUCK BOWMAN 304-558-2157

VENDOR

\*B19160306      304-622-2400  
 PRO CONTRACTING INC  
 PO BOX 2442  
 CLARKSBURG WV 26301

SHIP TO

ENVIRONMENTAL PROTECTION  
 DEPT. OF  
 OFFICE OF SPECIAL RECLAMATION  
 105 S. RAILROAD STREET  
 PHILIPPI, WV  
 26416-9998      304-457-3219

DATE PRINTED	TERMS OF SALE	SHIP VIA	F.O.B.	FREIGHT TERMS
08/25/2010				

BID OPENING DATE: **10/21/2010**      BID OPENING TIME: **01:30PM**

LINE	QUANTITY	UOP	CAT. NO.	ITEM NUMBER	UNIT PRICE	AMOUNT
				<p><b>CONSTRUCTION PROJECT ADDENDA FOR STATE AGENCIES:</b></p> <p>(1) THE ARCHITECT/ENGINEER SHALL PREPARE THE ADDENDUM AND A LIST OF ALL PARTIES THAT HAVE PROCURED DRAWINGS AND SPECIFICATIONS FOR THE PROJECT. THE ADDENDUM AND LIST SHALL BE FORWARDED TO THE BUYER IN THE STATE PURCHASING DIVISION. THE ARCHITECT/ENGINEER SHALL ALSO SEND A COPY OF THE ADDENDUM TO THE STATE AGENCY FOR WHICH THE CONTRACT IS ISSUED.</p> <p>(2) THE BUYER SHALL SEND THE ADDENDUM TO ALL INTERESTED PARTIES AND, IF NECESSARY, EXTEND THE BID OPENING DATE. ANY ADDENDUM SHOULD BE RECEIVED BY THE BUYER WITHIN FOURTEEN (14) DAYS PRIOR TO THE BID OPENING DATE.</p> <p>(3) ALL ADDENDA SHOULD BE FORMALLY ACKNOWLEDGED BY ALL BIDDERS AND SUBMITTED TO THE STATE PURCHASING DIVISION. THE SAME RULES AND REGULATIONS THAT APPLY TO THE ORIGINAL BIDDING DOCUMENT SHALL ALSO APPLY TO AN ADDENDUM DOCUMENT. THE ONLY EXCEPTION MAY BE FOR AN ADDENDUM THAT IS ISSUED FOR THE SOLE PURPOSE OF CHANGING A BID OPENING TIME AND/OR DATE.</p> <p>REV. 11/96</p> <p>EXHIBIT 10</p> <p>ADDENDUM ACKNOWLEDGEMENT</p> <p>I HEREBY ACKNOWLEDGE RECEIPT OF THE FOLLOWING CHECKED ADDENDUM(S) AND HAVE MADE THE NECESSARY REVISIONS TO MY PROPOSAL, PLANS AND/OR SPECIFICATION, ETC.</p>		

SEE REVERSE SIDE FOR TERMS AND CONDITIONS

SIGNATURE	TELEPHONE	DATE
<i>[Signature]</i>	304-622-2400	10-20-10
TITLE	FEIN	ADDRESS CHANGES TO BE NOTED ABOVE
Vice President	26-3348227	

WHEN RESPONDING TO RFQ, INSERT NAME AND ADDRESS IN SPACE ABOVE LABELED 'VENDOR'



State of West Virginia  
 Department of Administration  
 Purchasing Division  
 2019 Washington Street East  
 Post Office Box 50130  
 Charleston, WV 25305-0130

# Request for Quotation

RFQ NUMBER
DEP15165

PAGE
10

ADDRESS CORRESPONDENCE TO ATTENTION OF
CHUCK BOWMAN 304-558-2157

PURCHASER

\*B19160306 304-622-2400  
 PRO CONTRACTING INC  
 PO BOX 2442  
 CLARKSBURG WV 26301

SHIP TO

ENVIRONMENTAL PROTECTION  
 DEPT. OF  
 OFFICE OF SPECIAL RECLAMATION  
 105 S. RAILROAD STREET  
 PHILIPPI, WV  
 26416-9998 304-457-3219

DATE PRINTED	TERMS OF SALE	SHIP VIA	F.O.B.	FREIGHT TERMS
08/25/2010				

BID OPENING DATE: 10/21/2010 BID OPENING TIME 01:30PM

LINE	QUANTITY	UOP	CAT NO	ITEM NUMBER	UNIT PRICE	AMOUNT
ADDENDUM NOS. :						
NO. 1		✓ 10-12-10				
NO. 2						
NO. 3						
NO. 4						
NO. 5						
<p>I UNDERSTAND THAT FAILURE TO CONFIRM THE RECEIPT OF THE ADDENDUM(S) MAY BE CAUSE FOR REJECTION OF THE BIDS.</p> <p>VENDOR MUST CLEARLY UNDERSTAND THAT ANY VERBAL REPRESENTATION MADE OR ASSUMED TO BE MADE DURING ANY ORAL DISCUSSION HELD BETWEEN VENDOR'S REPRESENTATIVES AND ANY STATE PERSONNEL IS NOT BINDING. ONLY THE INFORMATION ISSUED IN WRITING AND ADDED TO THE SPECIFICATIONS BY AN OFFICIAL ADDENDUM IS BINDING.</p> <p><i>[Signature]</i>.....SIGNATURE  <i>Pro Contracting, Inc.</i>.....COMPANY  <i>10/20/2010</i>.....DATE</p> <p>REV. 11/96</p> <p>NOTICE</p> <p>A SIGNED BID MUST BE SUBMITTED TO:            DEPARTMENT OF ADMINISTRATION</p>						

SEE REVERSE SIDE FOR TERMS AND CONDITIONS			
SIGNATURE <i>[Signature]</i>	TELEPHONE 304-622-2400	DATE 10-20-10	
TITLE Vice President	FEIN 26-3348207	ADDRESS CHANGES TO BE NOTED ABOVE	

WHEN RESPONDING TO RFQ, INSERT NAME AND ADDRESS IN SPACE ABOVE LABELED 'VENDOR'



State of West Virginia  
 Department of Administration  
 Purchasing Division  
 2019 Washington Street East  
 Post Office Box 50130  
 Charleston, WV 25305-0130

# Request for Quotation

RFO NUMBER
DEP15165

PAGE
11

ADDRESS CORRESPONDENCE TO ATTENTION OF
CHUCK BOWMAN 304-558-2157

VENDOR

\*B19160306      304-622-2400  
 PRO CONTRACTING INC  
 PO BOX 2442  
 CLARKSBURG WV 26301

SHIP TO

ENVIRONMENTAL PROTECTION  
 DEPT. OF  
 OFFICE OF SPECIAL RECLAMATION  
 105 S. RAILROAD STREET  
 PHILIPPI, WV  
 26416-9998      304-457-3219

DATE PRINTED	TERMS OF SALE	SHIP VIA	F.O.B.	FREIGHT TERMS
08/25/2010				

BID OPENING DATE:	10/21/2010	BID OPENING TIME	01:30PM
-------------------	------------	------------------	---------

LINE	QUANTITY	UOP	CAT NO	ITEM NUMBER	UNIT PRICE	AMOUNT
	PURCHASING DIVISION BUILDING 15 2019 WASHINGTON STREET, EAST CHARLESTON, WV 25305-0130					
	THE BID SHOULD CONTAIN THIS INFORMATION ON THE FACE OF THE ENVELOPE OR THE BID MAY NOT BE CONSIDERED:  SEALED BID					
	BUYER: CB-23 REQ. NO.: DEP15165 BID OPENING DATE: 10/21/2010 BID OPENING TIME: 1:30 P.M.					
	PLEASE PROVIDE A FAX NUMBER IN CASE IT IS NECESSARY TO CONTACT YOU REGARDING YOUR BID:  ----- 304 622- 2410 -----					
	PLEASE PRINT OR TYPE NAME OF PERSON TO CONTACT CONCERNING THIS QUOTE:  ----- STEVE SZABO -----					

SEE REVERSE SIDE FOR TERMS AND CONDITIONS

SIGNATURE <i>[Signature]</i>	TELEPHONE 304-622-2400	DATE 10-20-10
TITLE Vice President	FEIN 26-3348227	ADDRESS CHANGES TO BE NOTED ABOVE

WHEN RESPONDING TO RFQ, INSERT NAME AND ADDRESS IN SPACE ABOVE LABELED 'VENDOR'

WV-36a STATE OF WEST VIRGINIA  
REV. 1/29/02 PURCHASING CONTINUATION SHEET  
VENDOR:

BUYER CB-23	REQ. OR PO NO DEP15165
SPENDING UNIT WEST VIRGINIA DEPARTMENT OF ENVIRONMENTAL PROTECTION/OFFICE OF SPECIAL RECLAMATION	

### DIRECTIONS

**From Mt. Storm travel 8.0 miles east on U.S.  
Route 50, turn left on State Route 42 and  
travel to Elk Garden, turn right onto State  
Route 46 and travel 11.0 miles. The project is  
located on left below the road.**

<b>OFFICE OF SPECIAL RECLAMATION</b>	
<b>MASTELLER COAL CO. P-741</b>	
SCALE:	DRAWN BY:
DATE:	PROJECT NO:

WV-36a STATE OF WEST VIRGINIA  
 REV. 1/29/02 PURCHASING CONTINUATION SHEET  
 VENDOR:

BUYER CB-23	REQ. OR PO NO DEP15165
SPENDING UNIT WEST VIRGINIA DEPARTMENT OF ENVIRONMENTAL PROTECTION/OFFICE OF SPECIAL RECLAMATION	

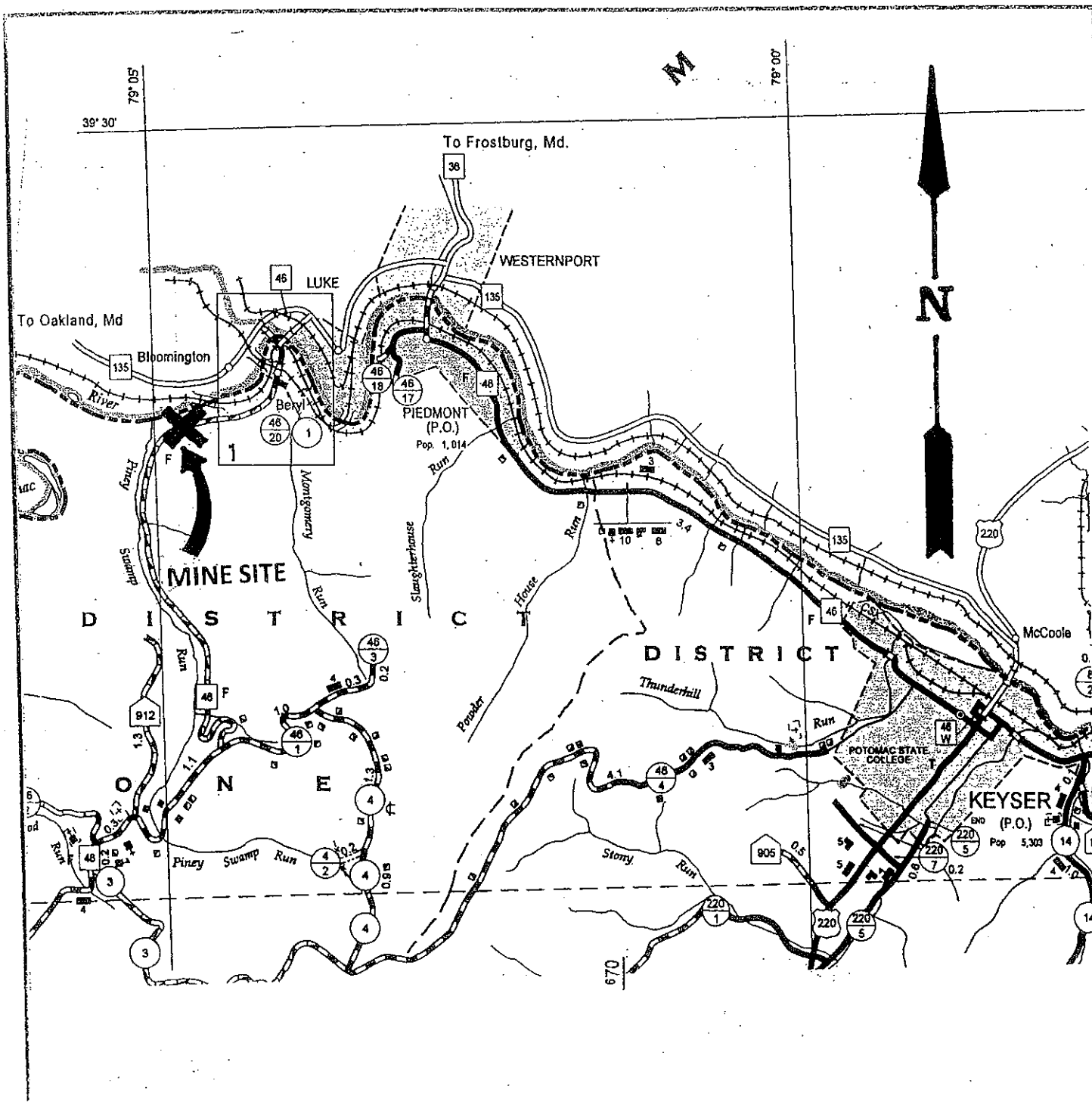

**LOCATION MAP**

OFFICE OF SPECIAL RECLAMATION

MASTELLER COAL CO. P-741

SCALE:

DRAWN BY:

BUYER CB-23	REQ. OR PO NO. DEP15165
SPENDING UNIT WEST VIRGINIA DEPARTMENT OF ENVIRONMENTAL PROTECTION/SPECIAL RECLAMATION	

WV-36a STATE OF WEST VIRGINIA  
REV. 5-26-09 PURCHASING CONTINUATION SHEET  
VENDOR:

### SCOPE OF WORK

The successful bidder shall provide appropriate equipment, materials, labor and any technical services needed for the successful reclamation of The Masteller Coal Co., Permit P-741, and any disturbance associated with such operation. The General Performance Standards (GPS) shall apply to all items in Scope of Work.

Work necessary on this site will include the following items, but is not limited to these:

1. Upon mobilization to the site, which will be directed in a written Notice to Proceed, the access roads shall be developed in accordance with bid item #3.0. If, fuel and lubricants are to be stored on site, bid item #2.0 shall be in place before fuel is delivered. Project sign shall be constructed and erected in accordance with attached specifications. The sign shall be maintained during construction activities and through the life of the warranty period. Sign cost is a No Bid Item and is included with mobilization cost. No work shall be authorized or allowed at the site until the sign is constructed and erected on site and approved by DEP.
2. Storm water management, as necessary, in the form as described, in the National Pollutant Discharge Elimination System, Water Pollution Control Permit Number WV0115924, existing sediment control ponds and in additional bid items # 10.0, 11.0 shall be installed.
3. Concurrent and continuous reclamation shall be maintained throughout the life of the project. Backfill is required for all areas. Regrading and topsoiling is required for all areas. Revegetation and soil improvements are required for all areas. Reclamation is to be according to the attached specifications, plans, and clarifying discussions at the Pre-Bid Conference.
4. Construction stakeout as necessary to carry out work. (Bid Item #7.0)
5. It shall be the contractor's responsibility to check for and locate all utilities within the work area to provide and maintain a safe working area in addition to preventing damage to the utility.
6. Remove any and all debris from site. Contractor must provide documentation of proper disposal. This shall also include all structures other than the three buildings designated to be left in place as shown on the site plan. Note: Any concrete and/or pavement may be broken into pieces no larger than four (4) feet in any direction and buried on site. Any reinforcing steel within the concrete pieces shall be removed to be flush with the concrete surfaces and shall be disposed of off site.
7. All asbestos containing material must be removed from the permit site. All asbestos containing material will be pointed out and identified at the Pre-bid Conference. The contractor shall be responsible for obtaining all permits and plans for proper cleanup and disposal of identified materials, this shall be incidental to and included in cost of asbestos removal. The contractor shall provide documentation of the proper disposal of these materials.
8. Pull back existing slopes, shown on site plan and pointed out during the Pre-Bid Conference. Final slopes to be no steeper than 2 horizontal to 1 vertical. This shall be incidental to and included in regrading.

BUYER CB-23	REQ. OR PO NO. DEP15165
SPENDING UNIT WEST VIRGINIA DEPARTMENT OF ENVIRONMENTAL PROTECTION/SPECIAL RECLAMATION	

WV-36a STATE OF WEST VIRGINIA  
REV. 5-26-09 PURCHASING CONTINUATION SHEET  
VENDOR:

9. Leave Access Road A in place, as shown on site plan. Provide and place up to 250 tons of three (3) inch and/or one and one half inch (1 ½) crusher run limestone to repair/reestablish Access Road A after construction. Stone shall be placed at the direction of the DEP agent on site.
10. Clean out the upper end of the pipe beneath Access Road A and reestablish the adjacent diversion located southwest of prospect area.
11. Disturbance of Access Road B and Access Road C shall be minimized. These areas shall have all debris removed and shall be revegetated. One water bar shall be installed on the lower end of Access Road C to direct water to the existing diversion.
12. Eliminate Pond E by regrading to establish a sheet flow drainage pattern.
13. Construct approximately 280 linear feet of Ditch 1 through the regraded Pond E area, to carry discharge from the existing diversion. Note: The upper end of the existing diversion shall be reestablished after debris is removed from the area of the diversion.
14. Backfill approximately 350 linear feet of highwall within the "prospect area". Backfilled slopes shall be no steeper than 2 horizontal to 1 vertical. Note: Topsoil material may be obtained for use on other areas from the "prospect area".
15. Construct approximately 225 linear feet of Ditch 2 to carry existing flow from drainage pipe through the regraded area.
16. Clean the diversion ditches by removing debris and/or material to reestablish drainage. This shall be incidental to and included in regrading.
17. Construct approximately 450 linear feet of Ditch 3 in existing gully to direct flow to the railroad siding diversion ditch. Construction of Ditch 3 shall include the removal of the existing pipe in the diversion and the construction of approximately 15 feet of grouted rip-rap within the diversion beyond Ditch 3. As Ditch 3 makes the turn into the existing diversion the outer side of the ditch shall be raised an additional two (2) feet in order to keep the water flow in Ditch 3 during high flow events.
18. Install 4,000 linear feet of silt fence and/or haybale dike for sediment control during and after reclamation. Location and which type to be used will be determined by DEP agent on site.
19. Sediment control sumps shall be constructed for stormwater management upon request of the DEP agent on site. (See details and specifications.)
20. All/black/coal/potentially toxic material shall be limed with agricultural lime at a rate of 5 tons per acre. The agricultural lime shall be uniformly spread over the black material and shall be tracked in. The black material shall then be covered with sufficient soil type material to support permanent vegetation.

BUYER CB-23	REQ. OR PO NO. DEP15165
SPENDING UNIT WEST VIRGINIA DEPARTMENT OF ENVIRONMENTAL PROTECTION/SPECIAL RECLAMATION	

WV-36a STATE OF WEST VIRGINIA  
REV. 5-26-09 PURCHASING CONTINUATION SHEET  
VENDOR:

21. Regrade and revegetate approximately 29 acres of disturbance.
22. Note: All bid items specified by the acre on this project in the Bid Schedule shall require the submittal of a final survey to verify final acreages. This submittal shall include a copy of all field notes and a map to scale in paper form and electronic form. Final survey must be conducted under the direct supervision of and certified by a Professional Surveyor or Professional Engineer licensed in the state of West Virginia. Partial payments may be made for estimated acreages that are field verified and agreed upon with the DEP agent on site. Partial payments may not exceed 75 percent of bid item prior to final survey.

I, David L. Martin, the undersigned, hereby certify<sup>1</sup> that this Reclamation Plan is correct and shows to the best of my knowledge and belief all the information required by the surface mining laws of the State of West Virginia. The source of information was the approved mining and reclamation plan contained in the forfeited surface mine permit, existing site conditions and information contained in the WV DEP, Inspection and Enforcement files.

David L. Martin, PE.  
Registered Professional Engineer WV No. 7202



Date: July 29, 2010

<sup>1</sup> The term "certify" as used herein is defined as follows: An engineer's certification of conditions is a declaration of professional judgment. It does not constitute a warranty or guarantee, either expressed or implied.



BUYER CB-23	REQ. OR PO NO. DEP15165
SPENDING UNIT WEST VIRGINIA DEPARTMENT OF ENVIRONMENTAL PROTECTION/SPECIAL RECLAMATION	

WV-36a STATE OF WEST VIRGINIA  
REV. 5-26-09 PURCHASING CONTINUATION SHEET  
VENDOR:

PRO CONTRACTING INC.  
P.O. BOX 2442  
CLARKSBURG, WV 26302

ITEM NO.	QUANTITY	DESCRIPTION	UNIT PRICE	AMOUNT
<b>BID SCHEDULE</b>				
<b>PERMIT NAME: <u>The Masteller Coal Co.</u></b>				
<b>PERMIT NUMBER(S): <u>P-741</u></b>				
The DEP reserves the right to request additional information and supporting documentation regarding unit prices when the unit price appears to be unreasonable.				
1.0	LUMP SUM	<b><u>MOBILIZATION/DEMobilIZATION/PROJECT SIGN</u></b> (5% Total Bid Maximum for this permit)	LUMP SUM	\$ <u>31,750<sup>00</sup></u>
2.0	LUMP SUM	<b><u>SPILL CONTAINMENT AREA (S.C.A.)</u></b> (\$1,000.00 Maximum Bid for this permit)	LUMP SUM	\$ <u>1,000<sup>00</sup></u>
3.0	LUMP SUM	<b><u>HAULROAD/ACCESS ROAD</u></b>	LUMP SUM	\$ <u>15,000<sup>00</sup></u>
3.1	<u>250 TON</u>	<b><u>INCIDENTAL STONE FOR ROAD UPGRADE</u></b>	\$ <u>32<sup>00</sup></u> PER TON	\$ <u>8,000<sup>00</sup></u>
4.0	LUMP SUM	<b><u>BACKFILLING</u></b>	LUMP SUM	\$ <u>200,000<sup>00</sup></u>
5.0	<u>29 AC</u>	<b><u>REGRAIDING AND TOPSOILING</u></b>	\$ <u>2,500<sup>00</sup></u> PER ACRE	\$ <u>72,500<sup>00</sup></u>
6.0	<b><u>REVEGETATION</u></b>			
6.1	<u>29 AC</u>	<b><u>AGRICULTURAL LIME</u></b>	\$ <u>100<sup>00</sup></u> PER ACRE	\$ <u>2,900<sup>00</sup></u>
6.2	<u>29 AC</u>	<b><u>FERTILIZER</u></b>	\$ <u>700<sup>00</sup></u> PER ACRE	\$ <u>20,300<sup>00</sup></u>
6.3	<u>29 AC</u>	<b><u>MULCH</u></b>	\$ <u>1000<sup>00</sup></u> PER ACRE	\$ <u>29,000<sup>00</sup></u>
6.4	<u>29 AC</u>	<b><u>VEGETATIVE SPECIES</u></b>	\$ <u>600<sup>00</sup></u> PER ACRE	\$ <u>17,400<sup>00</sup></u>
7.0	LUMP SUM	<b><u>CONSTRUCTION STAKEOUT</u></b> (Limited to 5% Total Bid)	LUMP SUM	\$ <u>31,750<sup>00</sup></u>
8.0	<u>1 EA</u>	<b><u>ELIMINATE POND E</u></b>	\$ <u>3,500<sup>00</sup></u> PER EA	\$ <u>3,500<sup>00</sup></u>

BUYER CB-23	REQ. OR PO NO. DEP15165
SPENDING UNIT WEST VIRGINIA DEPARTMENT OF ENVIRONMENTAL PROTECTION/SPECIAL RECLAMATION	

WV-36a STATE OF WEST VIRGINIA  
 REV. 5-26-09 PURCHASING CONTINUATION SHEET  
 VENDOR:

PRO CONTRACTING INC.  
 P.O. BOX 2442  
 CLARKSBURG, WV 26302

9.0	<u>125 Tons</u>	<u>LIMING</u>	\$ <u>200<sup>00</sup></u> PER TON	\$ <u>25,000<sup>00</sup></u>
10.0	<u>4,000 LF</u>	<u>SILT FENCE AND HAYBALE DIKE</u> (Max. Bid \$5.00 Per LF)	\$ <u>5<sup>00</sup></u> PER LF	\$ <u>20,000<sup>00</sup></u>
11.0	<u>10 EA</u>	<u>SEDIMENT CONTROL SUMPS</u>	\$ <u>350<sup>00</sup></u> PER EA	\$ <u>3,500<sup>00</sup></u>
12.0	<u>280 LF</u>	<u>RIPRAP DITCH 1</u>	\$ <u>21<sup>00</sup></u> PER LF	\$ <u>5,880<sup>00</sup></u>
13.0		<u>GROUTED RIPRAP DITCH</u>		
13.1	<u>225 LF</u>	<u>DITCH 2</u>	\$ <u>59<sup>00</sup></u> PER LF	\$ <u>13,275<sup>00</sup></u>
13.2	<u>450 LF</u>	<u>DITCH 3</u>	\$ <u>59<sup>00</sup></u> PER LF	\$ <u>26,550<sup>00</sup></u>
14.0	LUMP SUM	<u>STRUCTURE AND/OR DEBRIS REMOVAL</u>	LUMP SUM	\$ <u>125,000<sup>00</sup></u>
15.0	NO BID ITEM	<u>UTILITIES</u>	NO BID ITEM	
16.0	LUMP SUM	<u>ASBESTOS REMOVAL</u>	LUMP SUM	\$ <u>6,500<sup>00</sup></u>
		<b>TOTAL FOR PERMIT <u>P-741</u></b>		\$ <u>658,805<sup>00</sup></u>

BUYER CB-23		REQ. OR PO NO. DEP15165
SPENDING UNIT WEST VIRGINIA DEPARTMENT OF ENVIRONMENTAL PROTECTION/SPECIAL RECLAMATION		

WV-36a STATE OF WEST VIRGINIA  
REV. 5-26-09 PURCHASING CONTINUATION SHEET  
VENDOR:

## **BID ITEM TECHNICAL SPECIFICATIONS**

### **1.0 MOBILIZATION/DEMobilIZATION/PROJECT SIGN**

A project sign shall be obtained or manufactured and installed as indicated on the attached specifications and details. Payment for this sign shall be incidental to the mobilization item. No separate payment will be made. This work shall consist of the performance of construction preparatory operations, including the movement of personnel, equipment and other facilities to the project site necessary to begin work on a substantial phase of the contract.

Prior to demobilization, an inspection shall be conducted by the Department of Environmental Protection and the contractor to insure compliance with contract performance. Once compliance is ascertained, demobilization activities can be initiated and completed. Demobilization shall be totally completed before the invoice for payment shall be processed.

The lump sum bid for this item shall not exceed 5% of the total bid for this permit. Payment shall be made in two 50% amounts, one upon completion of the mobilization and project sign items and the second payment at the completion of demobilization. No deduction shall be made nor shall any increase be made in the lump sum item amount, regardless of decreases or increases in the final total contract amount or any other reason.

### **2.0 SPILL CONTAINMENT AREA (S.C.A.)**

Spill containment measures shall be used for fuel and lubricant storage areas. All containers, barrels, buckets, cans, etc., are to be legally disposed of off site. Used lubricants are to be disposed of according to state law to minimize pollution to the local surface and ground water supplies. Spills are the responsibility of the contractor and need immediate clean up and maintained at no expense to the State. This S.C.A. shall be constructed in accordance with the typical drawing specification. (See Attachment) Alternate containment measures will be considered for approval by the Program Manager if acceptable results can be shown. Fuel tanks manufactured with secondary containment are desirable. Minimum secondary containment is 110 percent. (Bid limited to \$1,000.00 maximum)

### **3.0 HAULROAD/ACCESS ROAD**

The contractor shall maintain and/or construct haulroad/access road(s) during the reclamation process to provide access on a well drained surface. The access road on the reclamation site shall be graded, sloped, and maintained to drain to provide a road surface free of excessive mud and standing waters at all times while work is in progress. Upon completion of all reclamation activities, a final 3 inch layer of 1 ½ crusher run limestone shall be placed on the roadway. Roads which are below the project shall be guarded against rolling rock and removal of rocks done as necessary. Dust-control measures may be necessary if hauling creates airborne material. Snow removal is to be included in this item.

### **3.1 INCIDENTAL STONE FOR ROAD UPGRADE**

During construction of culvert installations, roadway ditch improvements, and reshaping of the roadway, areas may need additional base layer stone. After any necessary re-compaction and re-grading work on roadways has been performed by the contractor, up to a six (6) inch layer of limestone (3.5" to 1.5" size) shall be placed as needed. This stone shall be graded and tracked in with a dozer or other equipment to achieve a compacted base for the final top layer of 1 ½ inch crusher run limestone. Payment shall be paid per ton of stone applied by weight ticket and will be made at completion of all work and acceptance by DEP.

BUYER CB-23	REQ. OR PO NO. DEP15165
SPENDING UNIT WEST VIRGINIA DEPARTMENT OF ENVIRONMENTAL PROTECTION/SPECIAL RECLAMATION	

WV-36a STATE OF WEST VIRGINIA  
REV. 5-26-09 PURCHASING CONTINUATION SHEET  
VENDOR:

#### **4.0 BACKFILLING**

Areas of this project subject to backfilling to achieve the post-mining land-use shall: be accomplished in a continuous concurrent manner on all surface disturbances within the original permit and associated disturbed areas as existing at bid showing; be filled by mechanical methods to eliminate highwall and rock outcropping, to produce slopes of consistent lines and of the approximate original contour; be free of protruding rock and debris; be compacted in a progressive backfilling manner with mechanical equipment to ensure stability of backfill material. The maximum acceptable slope of any backfill face shall not exceed two (2) horizontal to one (1) vertical, unless otherwise stated. Backfilling shall cease during periods of adverse site conditions. (For example: excessive soil moisture)

#### **5.0 REGRADING AND TOPSOILING**

Concurrent regrading and topsoiling shall immediately follow backfilling and shall distribute topsoil or the best available material to support vegetation, as identified by the Department of Environmental Protection contact person, on the surface of the backfill in a smooth, uniform manner. This item shall include the elimination of all rills and gullies, the grading of spoil and/or fill materials. Surface shall be free of all rock exceeding six (6) inches in diameter and shall be tracked, track to track. Topsoil presently stockpiled on site shall be preserved and spread on the fill surface. In the absence of stockpiled topsoil, material which can be used as a topsoil substitute shall be identified, segregated, and stockpiled for spreading on the surface. If necessary to manufacture fines, mechanical treatment to pulverize the surface layer shall be required. Regrading and topsoiling shall be conducted prior to and in preparation for the revegetation item. The contractor shall not exceed the contract amount. If any additional amount is required, the contractor must have written approval from the Director of the Division of Land Restoration or his designee, prior to any additional work being completed.

#### **6.0 REVEGETATION**

The actual seeding date, within the work performance period, shall be at the discretion of the contractor, but a permanent vegetative cover must be established. Verification of materials used shall be required for payment. Seed bed preparation, unless otherwise approved, shall be conducted by industrial disks or tracking with heavy equipment with cleat marks across slope and parallel to the final contours. The surface shall be tracked, track to track. Seeding shall commence after seedbed preparation on a loose and uncompacted soil and with the approval of the Department of Environmental Protection. Contractor shall provide equipment as necessary to secure approval of the seedbed. Revegetation activities shall be carried out in a continuous, concurrent, timely and uniform manner. Failure to do this may result in nonpayment for portions of or the entire Revegetation item. Hydroseeding or broadcast seeding with the approved species is acceptable. The application rate may be increased but the ratio is to remain constant, but no additional monetary compensation will be awarded. Areas outside the limits of construction, disturbed by the contractor, shall be revegetated by the contractor at no expense to DEP. Water utilized for hydroseeding shall be free of injurious or other toxic substances harmful to plant life. The source of water is subject to the approval of the DEP Specialist. It shall be the vendor's responsibility to repeat the procedures under REVEGETATION until a permanent vegetation is established. The acreage quantities in this contract are for bidding purposes only.

A warranty period of one (1) year shall commence upon completion and payment of the revegetation item of the contract. No payment will be made for additional seeding necessary to comply with warranty requirements. The warranty period will be extended for one (1) year from the date of the last augmented seeding done by the contractor. The performance bond and labor and materials bond shall remain in effect throughout the warranty period. The Standards for Evaluating Vegetative Cover as presented in Title 38, CSR2, Section 9 of the West Virginia Surface Mining Reclamation Regulations will apply.

BUYER CB-23		REQ. OR PO NO. DEP15165
SPENDING UNIT WEST VIRGINIA DEPARTMENT OF ENVIRONMENTAL PROTECTION/SPECIAL RECLAMATION		

WV-36a STATE OF WEST VIRGINIA  
REV. 5-26-09 PURCHASING CONTINUATION SHEET  
VENDOR:

Equipment for the retracking/scarification to eliminate rills and gullies shall be mobilized and utilized to produce slopes consistent with the regrading and topsoiling bid item prior to warranty reseeding. No additional payment will be made by DEP for this warranty work. The contractor shall not exceed the contract amount. If any additional amount is required, the contractor must have written approval from the Director of the Division of Land Restoration or his designee, prior to any additional work being completed.

### 6.1 AGRICULTURAL LIME

Unless otherwise specified, all lime used shall be registered with the West Virginia Department of Agriculture, have an 85% minimum calcium carbonate equivalent, and meet the fineness classification no larger than that for ground lime. The following fineness classifications or combinations of lime are acceptable:

- Pulverized - 100% passing a U.S. Standard 20 mesh sieve
- 70% passing a U.S. Standard 100 mesh sieve
- Ground - 90% passing a U.S. Standard 20 mesh sieve
- 50% passing a U.S. Standard 60 mesh sieve
- 35% passing a U.S. Standard 100 mesh sieve

Use of blends and low-grade agricultural liming materials shall require prior approval. Lime shall be spread as soon as possible after delivery to site. Lime shall be applied evenly and uniformly distributed over the treated area. Lime shall be thoroughly mixed into the soil material. Lime subjected to adverse conditions before spreading will be deemed unacceptable. Failure to complete this phase shall result in nonpayment of this bid item.

Lime shall be applied at 3 ton/acre.

### 6.2 FERTILIZER

Fertilizer rates given for REVEGETATION are for 1,000 lbs. of 10-20-20 per acre. These rates are minimum and for bidding purposes.

Fertilizer shall be applied evenly and uniformly distributed over the treated area. Common complete fertilizers which meet the minimum standards are acceptable.

### 6.3 MULCH

Acceptable mulch for this project is wood fiber, hay, or straw.

Mulch: Wood Fiber @ 1.0 ton/Acre

Hay or straw mulch may be substituted at a rate of 2 tons/Acre

### 6.4 VEGETATIVE SPECIES

Seeding rate required is for pure live seed (pls) in pounds per acre. The use of annuals or cover crops will not be considered for vegetative success.

VEGETATIVE SPECIES <sup>1</sup>	RATE/ACRE <sup>1</sup>
Orchard Grass	@ 15 lbs/acre
Birdsfoot Trefoil <sup>2</sup>	@ 15 lbs/acre
Yellow Sweet Clover	@ 5 lbs/acre
Red Clover	@ 10 lbs/acre
Ky 31 Fescue	@ 15 lbs/acre
Foxtail Millet <sup>3</sup>	@ 12 lbs/acre
Wheat or Rye <sup>4</sup>	@ 50 lbs/acre
Black Locust <sup>5</sup>	@ 3 lbs/acre

BUYER CB-23	REQ. OR PO NO. DEP15165
SPENDING UNIT WEST VIRGINIA DEPARTMENT OF ENVIRONMENTAL PROTECTION/SPECIAL RECLAMATION	

WV-36a STATE OF WEST VIRGINIA  
REV. 5-26-09 PURCHASING CONTINUATION SHEET  
VENDOR:

1. Seeding rate suggested is for pure live seed (pls) in pounds per acre.
2. Herbaceous legumes must be treated with the appropriate bacterium before seeding.
3. Spring mix.
4. Fall mix.
5. Black locust used only for woodland land use.

## 7.0 CONSTRUCTION STAKEOUT

This work shall consist of furnishing, placing, and maintaining construction layout stakes necessary for the proper execution of the work required under the Contract, production of as-built drawings, and of performing topographic surveys and obtaining surveyed cross-sections for accurate determination of pay item quantities. Construction stakeout shall be under the supervision of a Registered Professional Engineer or Licensed Land Surveyor and all drawings signed and/or sealed by such. The Department shall provide control points for initial layout of the work. (Shall not exceed 5% of the total bid for this permit.)

### A. MATERIALS

Wooden stakes and other marking materials as described herein.

### B. CONSTRUCTION METHODS

B(1). The Contractor shall locate and reference the construction baseline within the limits of work and shall establish bench marks for the proper layout of the work. The Contractor shall make all calculations involved and shall furnish and place all layout stakes or markers.

B(2). The Contractor shall provide field forces and shall set all additional stakes needed, such as offset stakes, reference point stakes, slope stakes, pavement and grade stakes, stakes for roadway drainage, sub-drains, trench drains, fence, culverts or other structures, supplementary bench marks and any other horizontal or vertical controls necessary to secure a correct layout of the work.

B(3). The location of the slope stakes for grading work shall be determined by a calculation method. Elevation control hubs with guard stakes shall be set, at a convenient distance outside the construction limits, and at all stations where original cross-sections are taken. The centerline station, the distance from centerline, and the elevation of the hub shall be recorded on each guard stake.

B(4). The Contractor shall be responsible for having the layout staking work conform to the lines, grades, elevations, and dimensions called for on the Plans. The Contractor shall be responsible for reporting any discrepancies to the Supervisor for clarification. Minor adjustments to suit field conditions are anticipated and it shall be the responsibility of the Supervisor to make decisions regarding adjustments.

B(5). The Contractor shall survey cross-sections and/or profiles in areas of on-site excavation, off-site excavation, and ditch construction as necessary to permit accurate determination of pay item quantities. The locations and spacing of cross-sections and profiles shall be as approved or as directed by the Supervisor. Cross-sections and profiles shall be surveyed:

- a) prior to any excavation
- b) at the completion of excavation

BUYER CB-23	REQ. OR PO NO. DEP15165
SPENDING UNIT WEST VIRGINIA DEPARTMENT OF ENVIRONMENTAL PROTECTION/SPECIAL RECLAMATION	

WV-36a STATE OF WEST VIRGINIA  
REV. 5-26-09 PURCHASING CONTINUATION SHEET  
VENDOR:

B(6). The Contractor shall furnish a copy of his survey records for the Supervisor and for the DEP's permanent file. These records shall be furnished as they are completed during the progress of the work. Any inspection or checking of the Contractor's layout by the Supervisor and the acceptance of all or any part of it shall not relieve the Contractor of his responsibility to secure the proper dimensions, grades and elevations of the required work.

### 8.0 EXISTING SEDIMENT CONTROL STRUCTURES

Existing structures shall be eliminated, cleaned out, repaired, or otherwise constructed as directed at the time of the pre-bid showing. Such structures shall be cleaned out when the sediment capacity reaches 60%, repaired, and maintained until demobilization. This item will be a one-time payment. Clean-out and maintenance shall be conducted by the contractor at no expense to DEP. (SEE ATTACHMENT)

### 9.0 LIMING

Liming of open pits is to be carried out at a rate of 40 tons/acre. All potentially toxic material shall be cleaned from the pavement prior to spreading lime uniformly over the exposed pavement. This potentially toxic material shall be placed on a pad prepared in the backfill. The top of the pad shall be a minimum of 4 ft. above the pavement, located out of any water course and away from the highwall. Lime shall be blended with the toxic material or (lime shall be spread over top of toxic material.) Coal refuse shall be treated in the same manner as the toxic material above and according to the attached specifications. Lime at a rate of 40 tons/1000 tons. (Unless exact tons or rate are specified in the Scope of Work)

Unless otherwise specified, all lime used shall be registered with the West Virginia Department of Agriculture, have an 85% minimum calcium carbonate equivalent, and meet the fineness classification no larger than that for ground. The following fineness classifications or combinations of are acceptable:

- Pulverized - 100% passing a U.S. Standard 20 mesh sieve
- 70% passing a U.S. Standard 100 mesh sieve
- Ground - 90% passing a U.S. Standard 20 mesh sieve
- 50% passing a U.S. Standard 60 mesh sieve
- 35% passing a U.S. Standard 100 mesh sieve

Use of blends and low-grade agricultural liming materials shall require prior approval. Lime shall be spread as soon as possible after delivery to site. Lime shall be applied evenly and uniformly distributed over the treated area. Lime shall be thoroughly mixed into the soil material. Lime subjected to adverse conditions before spreading will be deemed unacceptable. Failure to complete this phase shall result in nonpayment of this bid item.

### 10.0 SEDIMENT CONTROL WITH SILT FENCE AND HAYBALE DIKE

Disturbed areas which have storm water runoff and does not pass through a sediment control structure shall utilize the following Best Management Practice (BMP) methods to manage storm water runoff. For more information on BMP methods go to the WVDEP website <http://www.wvdep.org/dwwm/stormwater/BMP.htm> and click on **BMP Manual**. The WV Erosion and Sediment Control Best Management Practice Manual may be accessed or printed. This item has a Maximum Bid of \$5.00/LF of silt fence and hay bale material used on site.

BUYER CB-23		REQ. OR PO NO. DEP15165
SPENDING UNIT WEST VIRGINIA DEPARTMENT OF ENVIRONMENTAL PROTECTION/SPECIAL RECLAMATION		

WV-36a STATE OF WEST VIRGINIA  
REV. 5-26-09 PURCHASING CONTINUATION SHEET  
VENDOR:

1. Silt fence shall be utilized on perimeter barriers and shall be properly removed after permanent vegetation has been established. See attached drawing for further details.
2. For slope stability, place bales on the contour; at the top of cuts; and at the toe of slopes. Bales shall be placed in a row with ends tightly abutting the adjacent bales.
3. Bales shall be securely anchored in place by stakes or rebars driven through the bales. Rebar to be removed at the direction of DEP. The first stake in each bale shall be driven toward previously laid bale to force the bales together.
4. Construction of sediment control sumps and/or rock check dams may become necessary to supplement the silt fence and hay bale dikes. These items shall be installed upon request of the DEP onsite representative. Rock check dams shall be incidental to the ditch or sediment control sump it is constructed within.

#### **11.0 CONSTRUCTED SEDIMENT CONTROL SUMPS**

A sediment control structure shall be constructed as per attached detailed plans. Such structures shall be cleaned out when the sediment capacity reaches 60%, repaired, and maintained until demobilization. This item will be a one-time payment. Clean-out and maintenance shall be conducted by the contractor at no expense to DEP. (SEE ATTACHMENT)

#### **12.0 RIPRAP DITCH OR CHANNEL**

Provide all materials, excavate and construct ditch or channel as indicated on the attached typical plans, cross-section, specifications, and as discussed at the Pre-Bid Showing. Channels and ditches shall be free draining upon completion of construction. Length of channel may be adjusted to meet on site conditions. (See riprap specifications) R-5 limestone riprap shall be used at a thickness of 1 ½ feet.

#### **13.0 GROUTED RIPRAP DITCH**

Unless otherwise noted shall be durable rock placed in a 1.5 foot thick blanket. Twenty-five percent (25%) of the rock will be 18 inches or larger. Ten percent (10%) of the rock shall be no smaller than six (6) inches. The remaining sixty-five percent (65%) of the rock shall be well graded between six (6) and eighteen (18) inches. In-place rammed or hammered rock shall be acceptable.

The grout filler shall be composed of a mixture of one part Type II (sulfate resistant) portland cement and three parts sand, mixed with water to produce a workable consistency. The stone shall be thoroughly wet immediately before grout is applied. As soon as the grout is deposited on the surface, it shall be thoroughly worked into the joints. The stones shall then be brushed, so that their top surfaces are exposed. Grout shall penetrate 100% of the riprap thickness.

#### **14.0 STRUCTURE AND/OR DEBRIS REMOVAL**

All existing man-made items particular to the site and not to be utilized in the total reclamation of this site shall be demolished (if necessary) and disposed of in a legal manner. All iron, steel, aluminium, or any other metal, plastic, or any other man made material, including but not limited to I-Beams, Angle Iron, Channel Iron, Corrugated Metal, Flat Metal, Floc Drums, Grease Drums, Tires, Pipe or Conduit is to be dismantled, removed and properly disposed of off site and according to state, local, and federal requirements.



BUYER CB-23		REQ. OR PO NO. DEP15165
SPENDING UNIT WEST VIRGINIA DEPARTMENT OF ENVIRONMENTAL PROTECTION/SPECIAL RECLAMATION		

WV-36a STATE OF WEST VIRGINIA  
REV. 5-26-09 PURCHASING CONTINUATION SHEET  
VENDOR:

### **15.0 UTILITIES**

Utilities shall be relocated at the direction of the utility company and reimbursed actual cost to the contractor. This is a "No Bid" item due to the method of reimbursement. It is the contractor's responsibility to determine the exact location of each utility in the project area where these utilities would be interrupted or damaged by performing work.

### **16.0 ASBESTOS REMOVAL**

All asbestos or asbestos containing materials shall be removed and properly disposed off-site. Verification of disposal shall be required. Contractor shall obtain any necessary permits, specialized equipment, qualified personnel, etc. required. Asbestos inventory study will be provided to contractors at the pre-bid conference, and will be made part of the contract by being included in the Question and Answer Addendum.

## **BID PREPARATION INFORMATION**

### **HISTORICAL INFORMATION**

Prospective bidders may review files at the West Virginia Department of Environmental Protection, Charleston, WV office, or the Regional West Virginia Department of Environmental Protection Office at 105 South Railroad St., Philippi, WV 26416. These files may contain additional information not included in the contract. Documents including, but not limited to, permit applications, permits, inspection reports, environmental documents, permit violation history, geological and geotechnical information, probable hydrologic consequences, maps, modifications, NPDES information and other related data. Copies may be obtained upon request and payment of copying fees.

### **EXAMINATION OF BID PACKAGE AND SITE OF WORK**

The bidder is required to examine, carefully, the bid package (plans, specifications, supplemental specifications, contract forms, etc.) and the site of the work contemplated. The submission of a bid shall be considered prima facie evidence that the bidder has made such examination and has judged for and satisfied themselves as to the character, quantity, and quality of work to be performed and the materials required to be furnished under the contract.

### **PREBID CONFERENCE**

Only the prospective bidders on the sign-in sheet in attendance for the entire Pre-Bid Conference will be eligible to submit bids for consideration of this project. Considerable foot travel over rough terrain and/or inclement weather may be required.

### **VIDEO**

The information given at the pre-bid showing by the project contact person or the assigned person shall be documented on video tape and shall be an integral part of this contract's requirements, but will not supersede the written contract. All information on video tape that is new or provides clarification to the specifications will be issued in writing by a formal addendum and will become part of the written contract.

### **INTENT OF CONTRACT**

The intent of the contract is for the reclamation/restoration of forfeited mine lands as required by West Virginia Department of Environmental Protection. The contractor is to provide for the construction and completion in every detail of the work described. The Contractor shall furnish all labor, materials, equipment, tools, transportation, and supplies required to complete the work in accordance with the Plans, Specifications, and terms of the Contract.

Should any misunderstanding arise as to the intent or meaning of the Contract, or any discrepancy appears, the decision of the Director of Division of Land Restoration shall be final.

BUYER CB-23	REQ. OR PO NO. DEP15165
SPENDING UNIT WEST VIRGINIA DEPARTMENT OF ENVIRONMENTAL PROTECTION/SPECIAL RECLAMATION	

WV-36a            STATE OF WEST VIRGINIA  
REV. 5-26-09    PURCHASING CONTINUATION SHEET  
VENDOR:

## GENERAL PERFORMANCE STANDARDS

### INTRODUCTION

The performance standards and non-compliance penalties which govern special reclamation-bond forfeiture projects are in Chapter 22A, Article 3, of the Code of West Virginia and subsequent rules and regulations. The following performance standards are of a general nature and do not represent all the performance standards applicable to a special reclamation-bond forfeiture project. However, some or all of these standards will pertain to each project.

### BACKFILLING

1. Unless otherwise noted, the highwall shall be eliminated and the disturbed area graded to the approximate original contour.
2. The material used to backfill and eliminate the highwall shall be sufficiently compacted so as to insure stability of the backfill throughout the warranty period.
3. The land above the highwall shall not be disturbed unless otherwise directed.
4. The best available material to support vegetation, sufficient to establish a permanent vegetative cover and to achieve the approved post mining land use, shall be used.

### BLASTING

The performance standards of the blasting regulations must be adhered to.

### LIFE OF CONTRACT

The purchase order contract becomes effective on the starting date as specified in the notice to proceed as issued by the Department of Environmental Protection. This contract extends for a period of one (1) year and may be renewed until such "reasonable time" thereafter as is necessary to complete the payment therefore. A responsible Contractor's Agent shall be on the site at all working times who demonstrates a knowledge of mined land reclamation, contract requirements and responds to DEP (owner) inspections.

### WORK PERFORMANCE PERIOD

The work performance period is a defined portion of the contract in which all items shall be completed. The work performance period is to be performed within 365 calendar days. Extensions may be granted based upon contractor's performance, weather conditions and site-specific site conditions.

### NOTICE TO PROCEED

A notice to proceed shall be issued to the Contractor by the project contact person for the Department of Environmental Protection. Actual construction may only begin after a Notice to Proceed is given and as specified. Such notice shall specify the starting date of the Purchase Order, the work performance period, and the completion date of the work performance period.

BUYER CB-23		REQ. OR PO NO. DEP15165
SPENDING UNIT WEST VIRGINIA DEPARTMENT OF ENVIRONMENTAL PROTECTION/SPECIAL RECLAMATION		

WV-36a STATE OF WEST VIRGINIA  
REV. 5-26-09 PURCHASING CONTINUATION SHEET  
VENDOR:

### PRE-CONSTRUCTION CONFERENCE

The Contractor in possession of the awarded purchase order shall schedule a Pre-Construction Conference on the site within ten (10) days after receiving the Notice to Proceed. The Contractor's foreman or the on-the-ground supervisor must be in attendance.

### GENERAL SUPERVISION

This contact is under the general supervision of the West Virginia Department of Environmental Protection's contact person for the purpose of contract compliance inspection only. Contractor shall supervise work being conducted at all times. All services rendered by the Engineer/Contact Person consist of professional opinions and recommendations made in accordance with generally accepted engineering practice. Under no circumstances is it the intent of the Engineer/Contact Person to directly control the physical activities of the Contractor or the Contractor's workmen's accomplishment of work on this project.

### CONTRACTOR RESPONSIBILITY

The contractor is responsible for compliance with all aspects of this written contract. No changes will be honored without prior approval from the Program Supervisor.

### LAWS TO BE OBSERVED

The Contractor shall keep fully informed of all Federal and State laws, all local laws, ordinances, and regulations and all orders and decrees of bodies or tribunals having any jurisdiction or authority, which in any manner affect those engaged or employed on the work, or which in any way affect the conduct of the work. The Contractor shall at all times observe and comply with all such laws, ordinances, regulations, orders and decrees; and shall protect and indemnify the State and its representatives against any claim or liability arising from or based on the violation of any such laws, ordinances, regulations, orders, or decrees, whether by themselves, their subcontractors or their employees.

### PERMITS, LICENSES AND TAXES

The Contractor shall procure all permits and licenses, pay all charges, fees, and taxes, and give all notices necessary and incidental to the due and lawful prosecution of the work.

### CONCURRENT RECLAMATION

Reclamation of this project shall commence at a definite point as defined and shall progress from that point with total reclamation to include backfilling, grading/regrading, and revegetation. Changes may be granted based upon weather or differing site conditions with prior approval.

### WATER QUALITY CONTROL

Shall commence with initial start-up of the project and remain in effect for the extent of the backfilling, regrading and revegetation activity. DEP obtains a storm water permit for each project from the Water Resources Division. (General Water Pollution Control Permit WVO115924) The Contractor is responsible for performing the best management practices. Adequate facilities shall be installed, operated and maintained using the best management practices of the U.S. Environmental Protection Agency's Non-Point Source (NPS) Program for sediment control during the active reclamation. The contractor shall take any and all steps necessary to prevent erosion or silting problems from occurring and to minimize pollution or sedimentation of the stream. If any such problems develop, the contractor shall be responsible to take immediate corrective action. No separate payment for this work will be honored. All impounded waters which require removal during reclamation, shall be pumped with appropriate

BUYER CB-23		REQ. OR PO NO. DEP15165
SPENDING UNIT WEST VIRGINIA DEPARTMENT OF ENVIRONMENTAL PROTECTION/SPECIAL RECLAMATION		

WV-36a STATE OF WEST VIRGINIA  
REV. 5-26-09 PURCHASING CONTINUATION SHEET  
VENDOR:

measures taken to prevent erosion from the discharge. The contractor shall be responsible for treatment of said waters to meet pH standards. The water shall be discharged only when the quality meets a pH equivalent to the pH of the receiving stream but not less than 6.0.

### DIFFERING SITE CONDITIONS

During the progress of the work, if subsurface or latent physical conditions are encountered at the site differing materially from those indicated in the contract or if unknown physical conditions of an unusual nature, differing materially from those ordinarily encountered and generally recognized as inherent in the work provided by the contract, are encountered at the site, the party discovering such conditions shall promptly notify the other party in writing of the specific differing conditions before they are disturbed and before the affected work is performed.

Upon written notification, the Engineer/Contact Person will investigate the conditions, and if determined that the conditions materially differ and cause an increase or decrease in the cost or time required for the performance of any work under the contract, an adjustment, excluding loss of anticipated profits, will be made and the contract modified in writing accordingly. The Engineer/Contact Person will notify the Contractor of DEP's determination whether or not an adjustment of the contract is warranted.

No contract adjustment which results in a benefit to the Contractor will be allowed unless the Contractor has provided the required written notice.

No contract adjustment will be allowed under this clause for any effects caused on unchanged work.

### HANDLING AND STORAGE OF MATERIALS

Materials which are stored on site, before utilization, shall be stored so as to assure the preservation of their quality and fitness for the work. Stored materials, even though approved before storage, may be inspected again prior to their use in the work. Damaged or deteriorated materials shall be removed and replaced by materials meeting the original specifications.

Aggregate stockpiles shall be made on ground that is denuded of vegetation, hard, and well drained. Removal of aggregate from the stockpile shall be done in a manner which will not result in the inclusion of foreign material into the aggregate. The use of the aggregate will determine if exceptions are permitted.

All materials shall be handled in such a manner as to preserve their quality and fitness for the work.

### MAINTENANCE DURING CONSTRUCTION

The contractor shall maintain the work during construction and until the project is accepted. All cost of maintenance work during construction and before the project is accepted shall be included in the unit or lump sum prices on the various pay items.

### FINAL INSPECTION

A final inspection meeting by the Department of Environmental Protection's Specialist and the contractor is required for the construction phase and prior to demobilization.

### ACREAGE QUANTITIES

The acreage quantities in this contract are for bidding purpose and are set (definite) number for the project area as specified at the pre-bid showing. Only surveyed acreage's through figures the Contractor and/or the State develops will be honored to alter these acreage numbers.

BUYER CB-23	REQ. OR PO NO. DEP15165
SPENDING UNIT WEST VIRGINIA DEPARTMENT OF ENVIRONMENTAL PROTECTION/SPECIAL RECLAMATION	

WV-36a STATE OF WEST VIRGINIA  
REV. 5-26-09 PURCHASING CONTINUATION SHEET  
VENDOR:

### PAYMENT

Invoices must be submitted on prescribed Department of Environmental Protection, Special Reclamation Program forms and include verification. Certified contractor payrolls for operators directly involved in this project and a current workers compensation certificate must accompany each invoice for payment. Verification of wage rates may include employee interviews. Invoices shall be signed in blue ink so that it is easy to verify that document is an original. Vendor should submit with their bid the current remit-to address to be used for payment processing.

MOBILIZATION/DEMobilIZATION shall be invoiced at fifty percent (50%) with the first invoice and the last 50% invoiced after demobilization and acceptance of the road abandonment or final invoice. Demobilization must have written approval.

SPILL CONTAINMENT AREA shall not exceed \$1,000.00 and will be payable in two payments. The first fifty percent (50%) payable with the first invoice and the remainder payable when all fuel tanks, containers and etc., are removed from the site.

Lump sum items shall be percentage payments based on work completed at time of invoice and paid upon acceptance by the Department of Environmental Protection.

Unit items shall be invoiced by specified units completed and accepted by the DEP.

ROAD ABANDONMENT shall be included in the final construction invoice.

### FAILURE TO COMPLETE ON TIME AND LIQUIDATED DAMAGES

Time is an essential element of the Contract and it is important that the work be completed within the time specified. The cost to the Department of the administration of the Contract, including engineering, inspection and supervision, will increase as the time required to complete the work is increased.

The work performance period as specified in the contract's Notice to Proceed shall be complied with or result in liquidated damages. Such damages shall be assessed at an amount of two hundred and fifty dollars (\$250.00) per day for each and every day beyond the work performance period as specified in the Notice to Proceed. The total amount of daily charges will be deducted from any moneys due the Contractor, not as a penalty but as liquidated damages.

### REVEGETATION AND WARRANTY

The seeding date shall be at the discretion of the contractor once an approved seedbed has been prepared. In all cases a permanent vegetative cover capable of supporting the post-mining land use must be established. A warranty period of one (1) year shall commence upon completion and payment of the revegetation item of the contract. No payment will be made for additional seeding necessary to comply with warranty requirements. The warranty period will be extended for one (1) year from the date of the last augmented seeding done by the contractor. The performance bond and labor and materials bond shall remain in effect throughout the warranty period. The Standards for Evaluating Vegetative Cover as presented in Title 38, CSR2, Section 9 of the West Virginia Surface Mining Reclamation Regulations will apply.

Equipment for the retracking/scarification to eliminate rills and gullies shall be mobilized and utilized to produce slopes consistent with the regrading and topsoiling bid item prior to warranty reseeding. No additional payment will be made by DEP for this warranty work.

Water utilized for hydroseeding shall be free of injurious or other toxic substances harmful to plant life. The source of water is subject to the approval of the DEP contact person.

BUYER CB-23		REQ. OR PO NO. DEP15165
SPENDING UNIT WEST VIRGINIA DEPARTMENT OF ENVIRONMENTAL PROTECTION/SPECIAL RECLAMATION		

WV-36a STATE OF WEST VIRGINIA  
 REV. 5-26-09 PURCHASING CONTINUATION SHEET  
 VENDOR:

---

### CONTRACT NON-COMPLIANCE

If in the opinion of the Department of Environmental Protection the contract is not in compliance with any line item specification, that portion of the project shall cease until a compliance schedule and understanding is demonstrated in writing and accepted by the Director of Division of Land Restoration.

### CONTRACT DELETIONS

Any line item, or any portion thereof, may be deleted when determined by the project contact person that such line item or portion thereof, is deemed unnecessary for the successful reclamation of this project. No claim for loss of anticipated profits will be considered.

### CANCELLATION

The performance of work under contract may be terminated by the State in whole, or from time to time in part whenever the State shall determine that such termination is in the best interest of the State. Any such termination shall be effected by delivery to the Contractor of a Notice of Termination specifying the extent to which performance of work under the Contract is terminated and the date upon which such termination becomes effective.

When contracts, or any portion thereof, are terminated before completion of all items of work in the Contract, payment will be made for the actual number of units or items of work completed and accepted at the contract unit price. No claim for loss of anticipated profits will be considered. Reimbursement for organization of the work, when not otherwise included in the Contract, and moving equipment to and from the job will be considered where the volume of work completed and accepted is too small to compensate the Contractor for these expenses under the contract unit prices, the intent being that an equitable settlement will be made with the Contractor.

Termination of the Contract or a portion thereof shall not relieve the Contractor of his responsibilities for the completed work, nor shall it relieve his surety of its obligation for and concerning any just claims arising out of the work performed.

This contract may be cancelled in whole or in part in writing by the Director of Purchasing, without prejudice to any other right or remedy it may have, provided that the contractor is given not less than thirty (30) calendar days written notice, (delivered by certified mail, return receipt requested) of intent to terminate. This contract objective is to comply with the reclamation laws of this state and must be expedient to meet the time requirements for reclamation of revoked surface mine permits.

BUYER CB-23	REQ. OR PO NO. DEP15165
SPENDING UNIT WEST VIRGINIA DEPARTMENT OF ENVIRONMENTAL PROTECTION/SPECIAL RECLAMATION	

WV-36a STATE OF WEST VIRGINIA  
REV. 5-26-09 PURCHASING CONTINUATION SHEET  
VENDOR:

S

Attn:

Re: Notice to Proceed  
Permit Name: \_\_\_\_\_  
Permit No. \_\_\_\_\_  
Purchase Order No.: DEP\_\_\_\_\_

Dear :

The purpose of this letter is to express our appreciation for your work in advance and to recognize a reclamation partnership project. The official starting date for the above mentioned purchase order is . The work performance period must be completed by . The contract life of one year is provided to accomplish all line items and to process all payments within that period.

You must schedule a pre-construction conference on site within ten (10) days after receiving this notice to proceed. It is then mandatory that construction begins within ten (10) days of the pre-construction conference and continues diligently until completion of the project. Please contact this office to schedule the pre-construction conference. The foreman, superintendent, or on-the-ground supervisor must be in attendance at this conference.

Failure to comply with this notice to proceed will cause termination of the contract and forfeiture of your performance bond.

If you have any questions please feel free to contact this office.

Sincerely,

E

BUYER CB-23	REQ. OR PO NO. DEP15165
SPENDING UNIT WEST VIRGINIA DEPARTMENT OF ENVIRONMENTAL PROTECTION/SPECIAL RECLAMATION	

WV-36a STATE OF WEST VIRGINIA  
REV. 5-26-09 PURCHASING CONTINUATION SHEET  
VENDOR:

### General Requirements

#### Project Construction Sign

##### Work Required

The work to be performed under this Section consists of providing all labor, material and equipment necessary to install a project sign as indicated on the detail included herein and as specified herein.

##### Materials

Paint. Paint for the project sign shall be one (1) coat Exterior-Grade Wood Primer- Sealer, and two (2) coats Exterior-Grade Enamel by Glidden or equivalent.

Wood. Sign face shall be 3/4" X 4' X 8' Marine Exterior plywood, and posts and cross braces shall be treated.

Hardware. All hardware shall be manufactured from good, commercial-quality material and be rust resistant such as galvanized coated.

##### Execution

Project Sign. The signboard shall be cut to the dimensions shown on the details herein. The sign shall be painted with one (1) coat of primer and two (2) coats of white enamel. All exterior cut edges shall be smooth sanded prior to painting. All edges shall be double primed. The letters, border and strips shall be painted as shown on the detail drawing.

The Contractor shall bolt the sign to posts and provide required cross bracing. The posts and sign shall be erected and posts set in gravel base, as shown on the drawings. One (1) sign is required and is to be located at the direction of WVDEP.

Payment. Payment for the work which shall include installation of the project sign shall be incidental to the lump sum bid item for "Mobilization/Demobilization"

Note: No construction work shall commence prior to the project sign being installed.



WV-36a STATE OF WEST VIRGINIA  
REV. 1/29/02 PURCHASING CONTINUATION SHEET  
VENDOR:

BUYER CB-23	REQ. OR PO NO DEP15165
SPENDING UNIT WEST VIRGINIA DEPARTMENT OF ENVIRONMENTAL PROTECTION/OFFICE OF SPECIAL RECLAMATION	

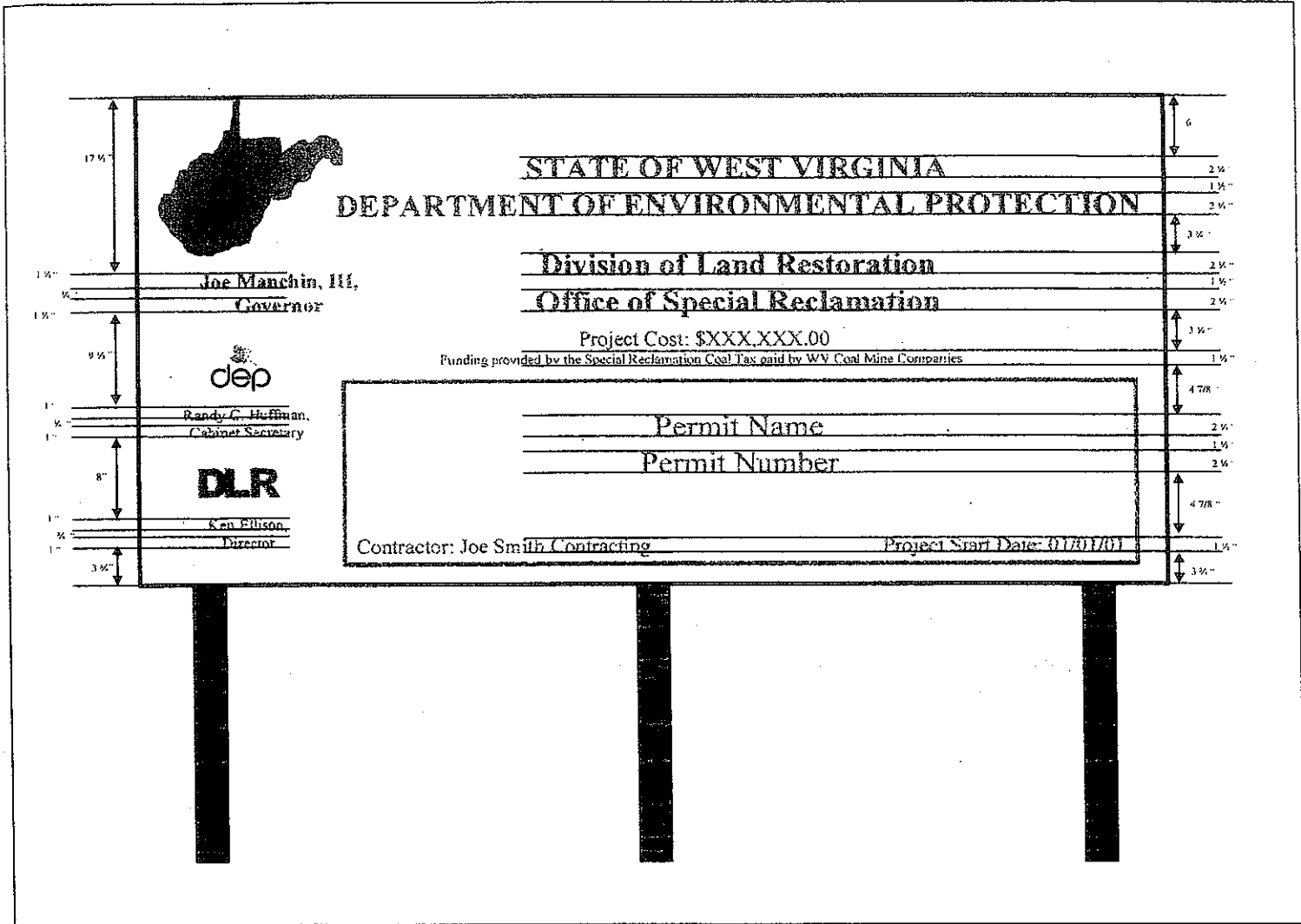

OFFICE OF SPECIAL RECLAMATION	
PROJECT CONSTRUCTION SIGN	
SCALE:	DRAWN BY:
DATE:	PROJECT NO:

WV-36a STATE OF WEST VIRGINIA  
REV. 1/29/02 PURCHASING CONTINUATION SHEET  
VENDOR:

BUYER CB-23	REQ. OR PO NO DEP15165
SPENDING UNIT WEST VIRGINIA DEPARTMENT OF ENVIRONMENTAL PROTECTION/OFFICE OF SPECIAL RECLAMATION	

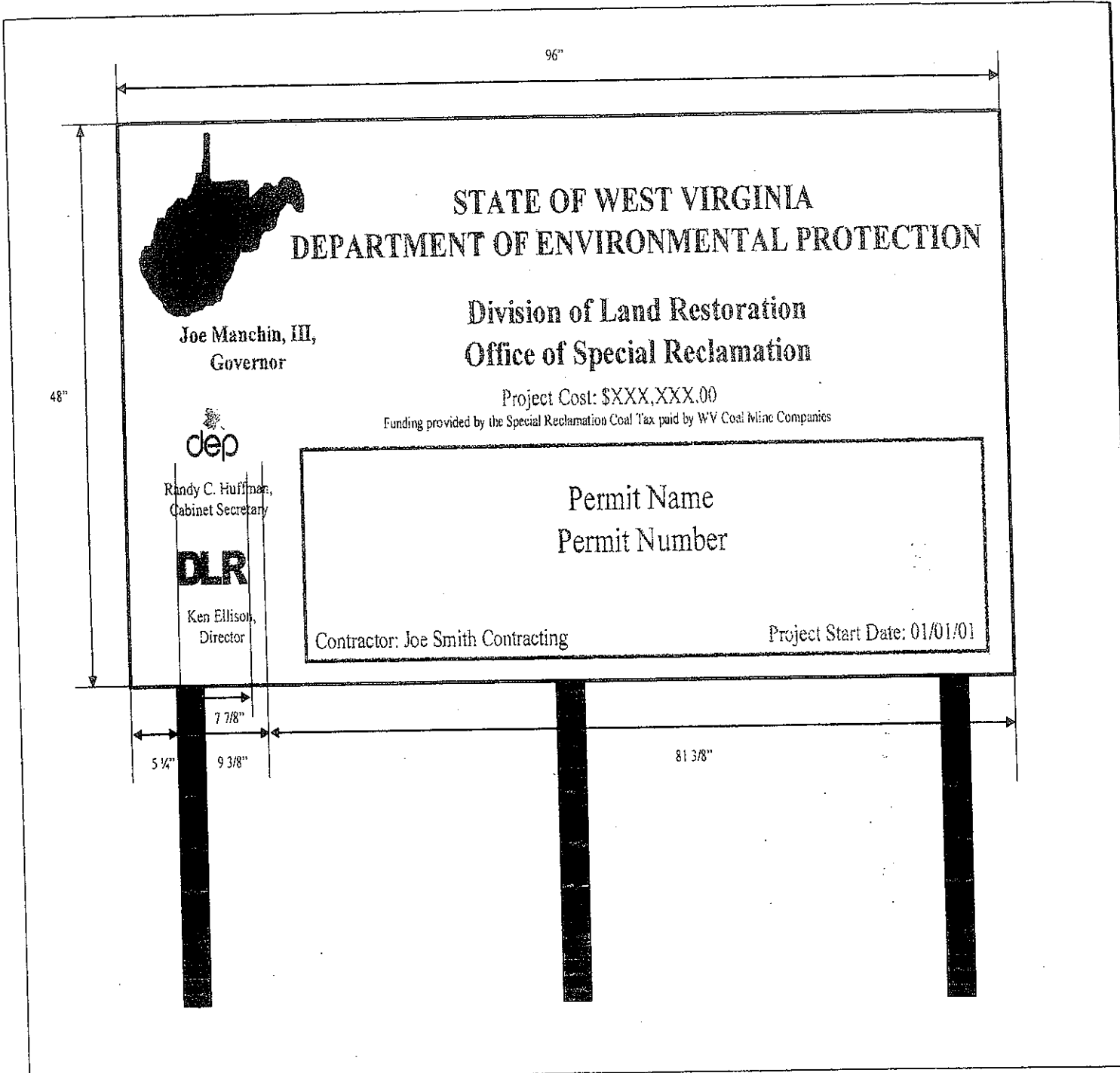

STATE OF WEST VIRGINIA  
DEPARTMENT OF ENVIRONMENTAL PROTECTION



Joe Manchin, III,  
Governor

Division of Land Restoration  
Office of Special Reclamation

Project Cost: \$XXX,XXX.00

Funding provided by the Special Reclamation Coal Tax paid by WV Coal Mine Companies



Randy C. Huffmas,  
Cabinet Secretary



Ken Ellison,  
Director

Permit Name Permit Number
Contractor: Joe Smith Contracting
Project Start Date: 01/01/01

OFFICE OF SPECIAL RECLAMATION	
PROJECT CONSTRUCTION SIGN	
SCALE:	DRAWN BY:
DATE:	PROJECT NO.:

WV-36a STATE OF WEST VIRGINIA  
 REV. 1/29/02 PURCHASING CONTINUATION SHEET  
 VENDOR:

BUYER CB-23	REQ. OR PO NO DEP15165
SPENDING UNIT WEST VIRGINIA DEPARTMENT OF ENVIRONMENTAL PROTECTION/OFFICE OF SPECIAL RECLAMATION	

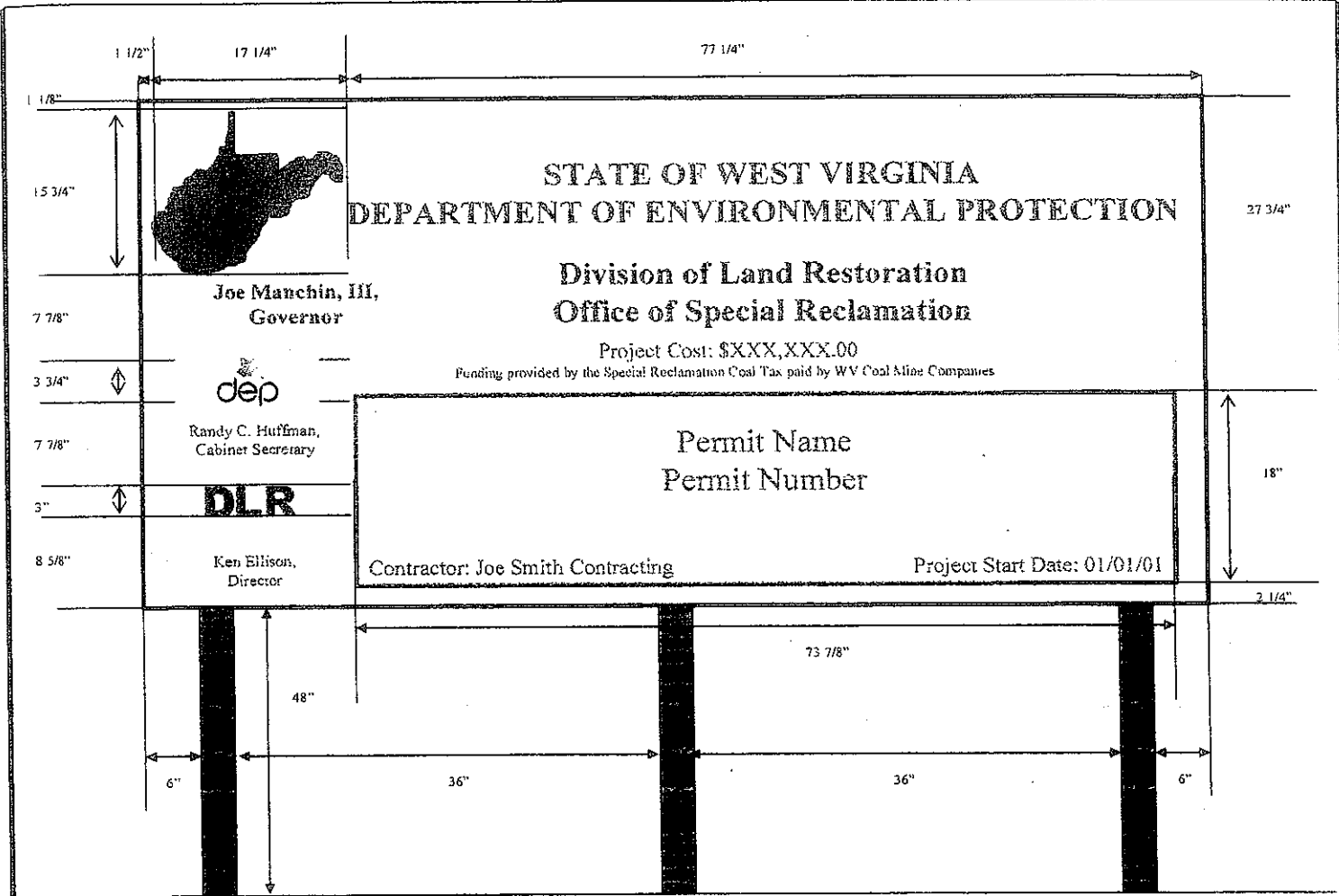

OFFICE OF SPECIAL RECLAMATION	
PROJECT CONSTRUCTION SIGN	
SCALE:	DRAWN BY:
DATE:	PROJECT NO.:

WV-36a STATE OF WEST VIRGINIA  
REV. 1/29/02 PURCHASING CONTINUATION SHEET  
VENDOR:

BUYER	NO. OR PO
CB-23	DEP15165
SPENDING UNIT	
WEST VIRGINIA DEPARTMENT OF ENVIRONMENTAL PROTECTION/OFFICE OF SPECIAL RECLAMATION	



**STATE OF WEST VIRGINIA**  
**DEPARTMENT OF ENVIRONMENTAL PROTECTION**

**Division of Land Restoration**  
**Office of Special Reclamation**

Project Cost: \$XXX,XXX.00  
Funding provided by the Special Reclamation Coal Tax paid by WV Coal Mine Companies

Joe Manchin, III,  
Governor



Randy C. Huffman,  
Cabinet Secretary



Ken Ellison,  
Director

Permit Name

Permit Number

Contractor: Joe Smith Contracting

Project Start Date: 01/01/01

<b>OFFICE OF SPECIAL RECLAMATION</b>	
<b>PROJECT CONSTRUCTION SIGN</b>	
SCALE:	DRAWN BY:
DATE:	PROJECT NO:

WV-36  
REV. 1/29/02  
VENDOR:

STATE OF WEST VIRGINIA  
PURCHASING CONTINUATION SHEET

BUYER CB-23	REQ. or P.O. No. DEP15165
SPENDING UNIT WEST VIRGINIA DEPARTMENT OF ENVIRONMENTAL PROTECTION SPECIAL RECLAMATION	

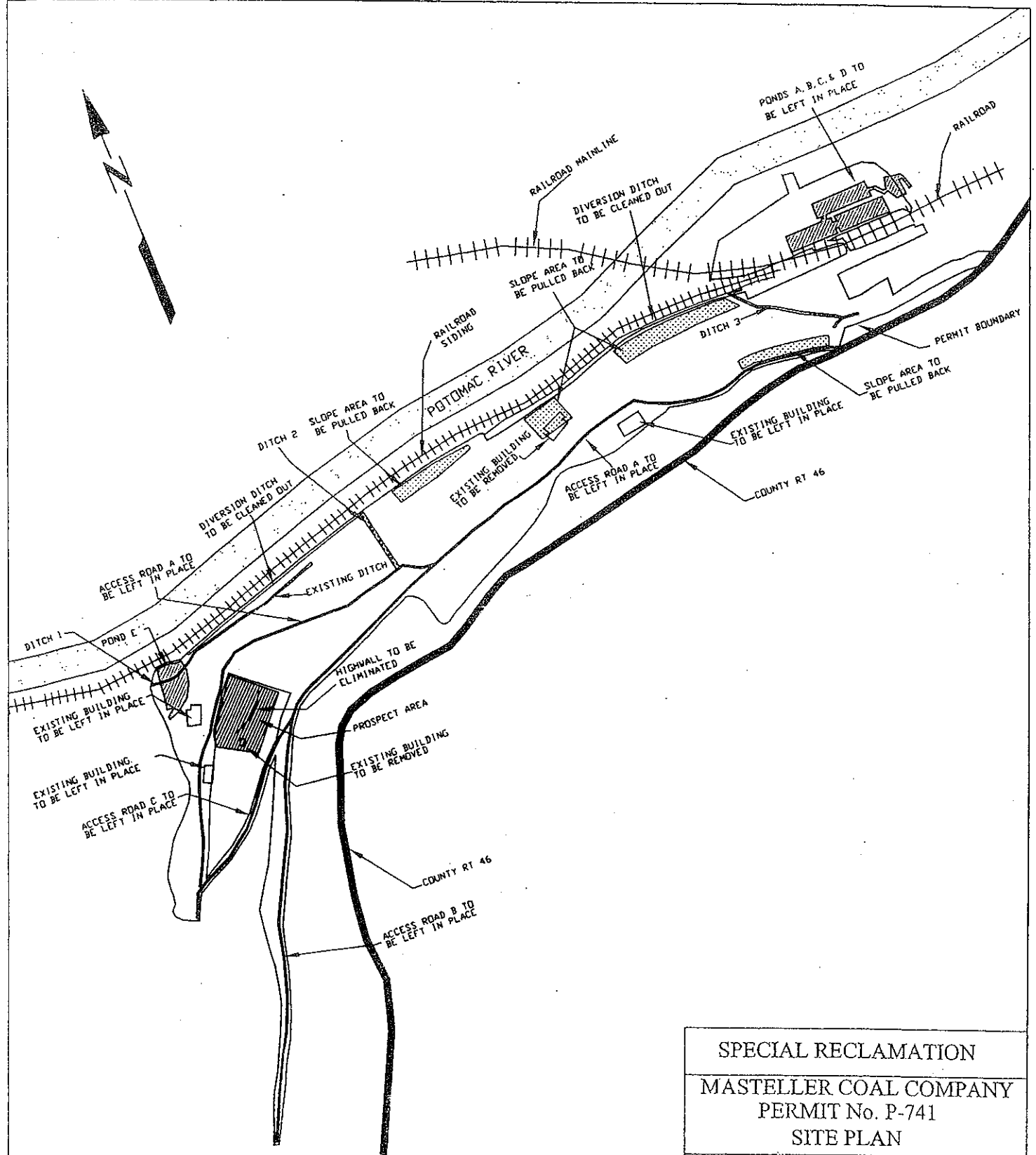

SPECIAL RECLAMATION  
MASTELLER COAL COMPANY  
PERMIT No. P-741  
SITE PLAN

SCALE: Not To Scale	DRAWN BY:
DATE:	PROJECT NO.:

BUYER CB-23	REQ. of P.O. No. DEP15165
SPENDING UNIT WEST VIRGINIA DEPARTMENT OF ENVIRONMENTAL PROTECTION/ SPECIAL RECLAMATION	

WV-36  
REV. 1/29/02  
VENDOR:

STATE OF WEST VIRGINIA  
PURCHASING CONTINUATION SHEET

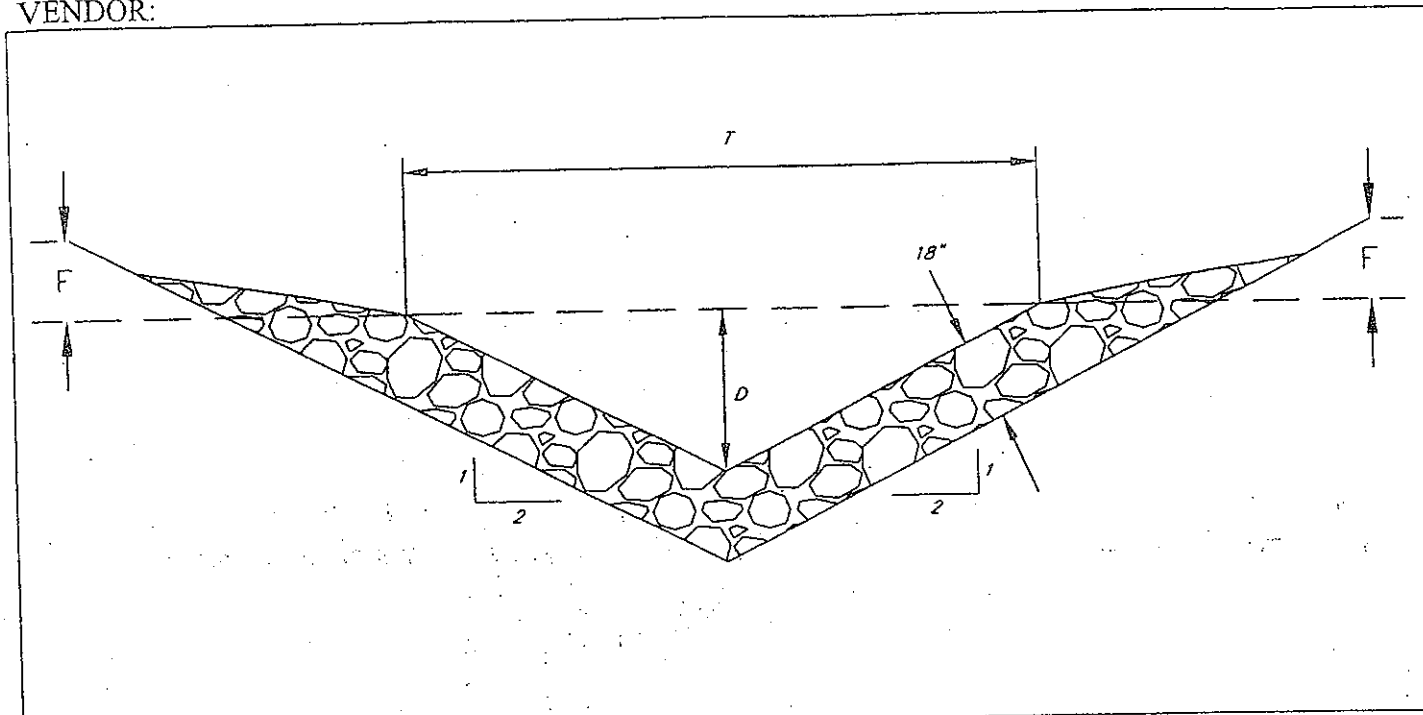

DITCH	DEPTH (ft) D	TOP WIDTH (ft) T	FREE BOARD (ft) F	LINING
1	1.0	4	1	LIMESTONE RIP-RAP
2	2.0	8	1	GROUTED LIMESTONE RIP-RAP
3	2.0	8	1	GROUTED LIMESTONE RIP-RAP

SPECIAL RECLAMATION	
MASTELLER COAL COMPANY FORFEITED PERMIT No. P-741 V-DITCH TYPICAL	
SCALE: Not To Scale	DRAWN BY:
DATE:	PROJECT NO.:

BUYER CB-23	REQ. or P.O. No. DEP15165
SPENDING UNIT WEST VIRGINIA DEPARTMENT OF ENVIRONMENTAL PROTECTION/ SPECIAL RECLAMATION	

WV-36 STATE OF WEST VIRGINIA  
 REV. 1/29/02 PURCHASING CONTINUATION SHEET  
 VENDOR:

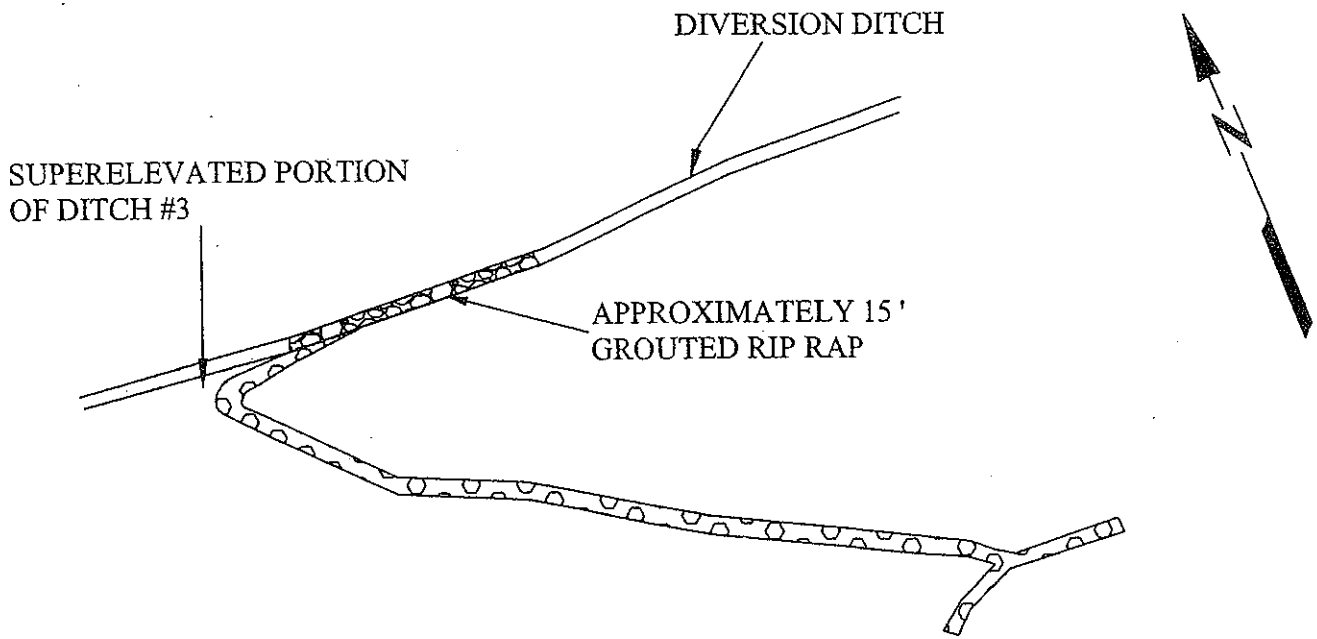
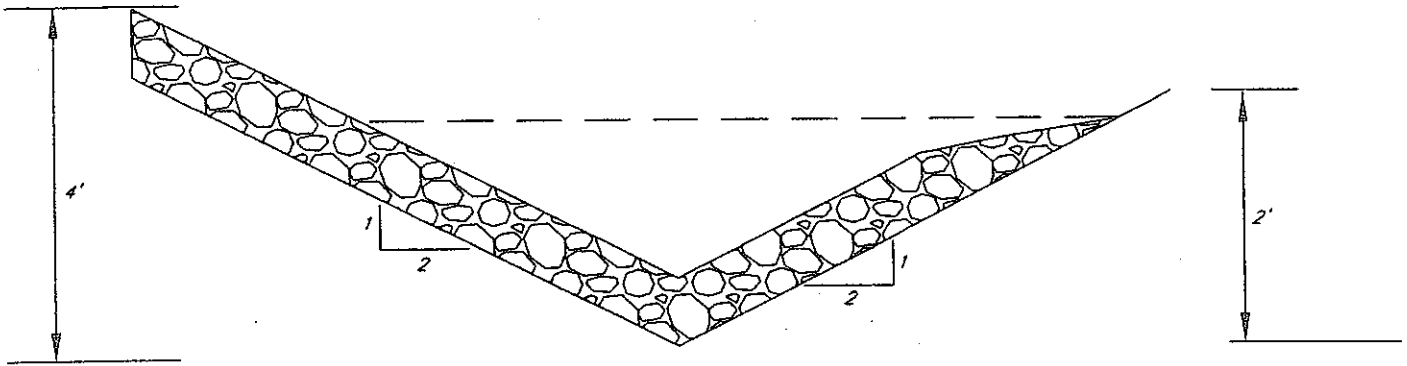

SPECIAL RECLAMATION	
MASTELLER COAL COMPANY FORFEITED PERMIT No. P-741 SUPERELEVATED BERM DETAIL	
SCALE: Not To Scale	DRAWN BY:
DATE:	PROJECT NO.:

WV-36  
REV. 1/29/02  
VENDOR:

STATE OF WEST VIRGINIA  
PURCHASING CONTINUATION SHEET

BUYER CB-23	REQ. or P.O. No. DEP15165
SPENDING UNIT WEST VIRGINIA DEPARTMENT OF ENVIRONMENTAL PROTECTION/ SPECIAL RECLAMATION	

# SILT FENCE

NOTE:  
THE MAXIMUM LENGTH  
OF SLOPE ABOVE  
A ROW OF SILT  
FENCE IS 110'

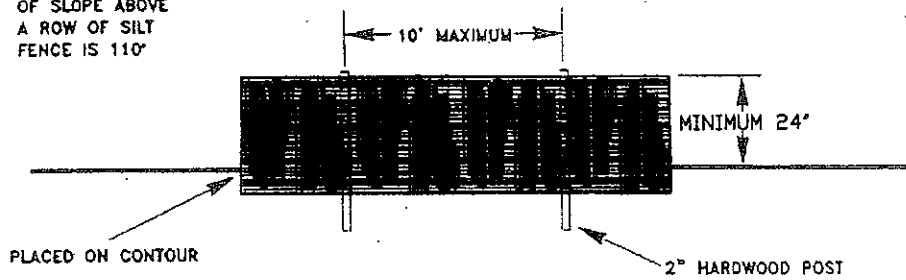

FRONT ELEVATION

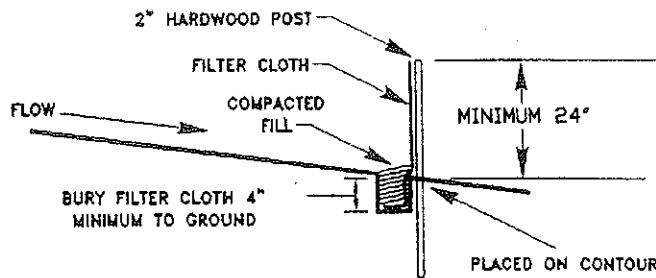

SIDE ELEVATION



TOP VIEW

## SPECIAL RECLAMATION

MASTELLER COAL COMPANY  
FORFEITED PERMIT No. P-741  
SILT FENCE

SCALE:  
Not To Scale  
DATE:

DRAWN BY:  
PROJECT NO.:



BUYER CB-23	REQ. of P.O. No. DEP15165
SPENDING UNIT WEST VIRGINIA DEPARTMENT OF ENVIRONMENTAL PROTECTION/ SPECIAL RECLAMATION	

WV-36 STATE OF WEST VIRGINIA  
REV. 1/29/02 PURCHASING CONTINUATION SHEET  
VENDOR:

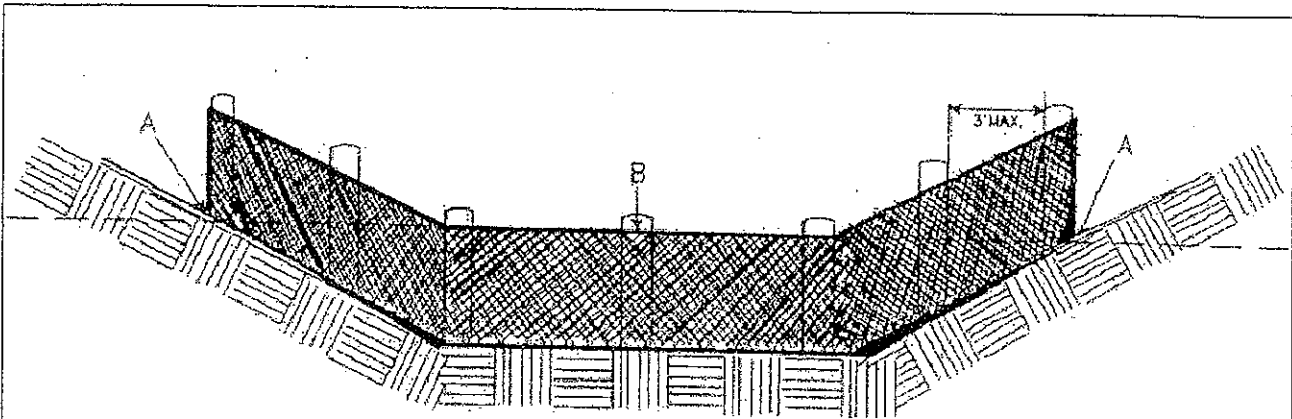

POINTS A SHOULD BE HIGHER THAN POINT B.  
DRAINAGEWAY INSTALLATION  
(FRONT ELEVATION)

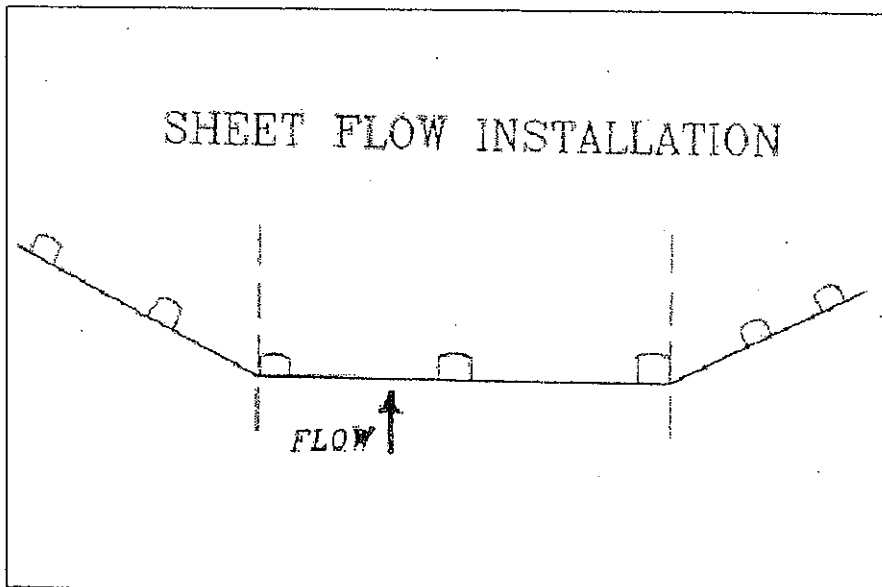

SHEET FLOW INSTALLATION

SPECIAL RECLAMATION	
MASTELLER COAL COMPANY FORFEITED PERMIT No. P-741 SILT FENCE	
SCALE: Not To Scale	DRAWN BY:
DATE:	PROJECT NO.:

BUYER CB-23	REQ. or P.O. No. DEP15165
SPENDING UNIT WEST VIRGINIA DEPARTMENT OF ENVIRONMENTAL PROTECTION/ SPECIAL RECLAMATION	

WV-36  
REV. 1/29/02  
VENDOR:

STATE OF WEST VIRGINIA  
PURCHASING CONTINUATION SHEET

PLACEMENT OF SILT FENCE

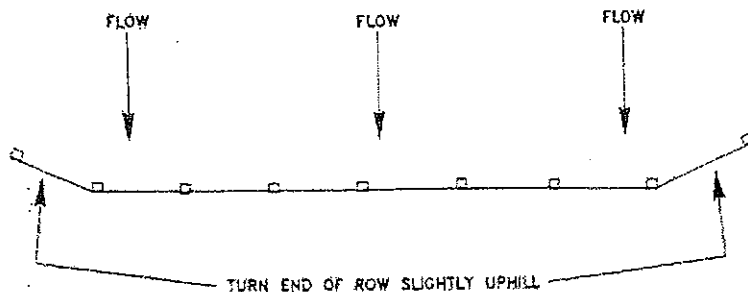
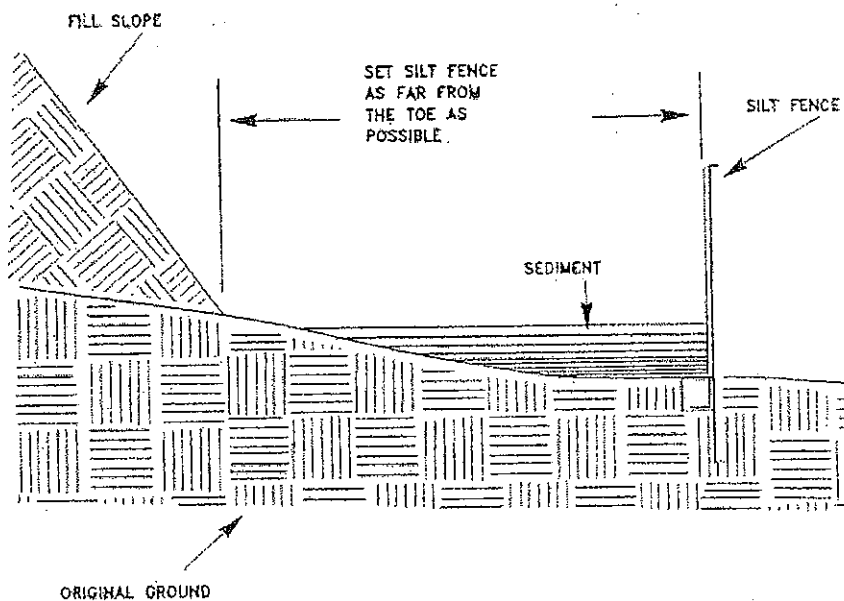

SPECIAL RECLAMATION	
MASTELLER COAL COMPANY FORFEITED PERMIT No. P-741 SILT FENCE	
SCALE: Not To Scale	DRAWN BY:
DATE:	PROJECT NO.:

BUYER CB-23	REQ. or P.O. No. DEP15165
HAY/STRAW BALE DIKE SEDIMENT CONTROL	

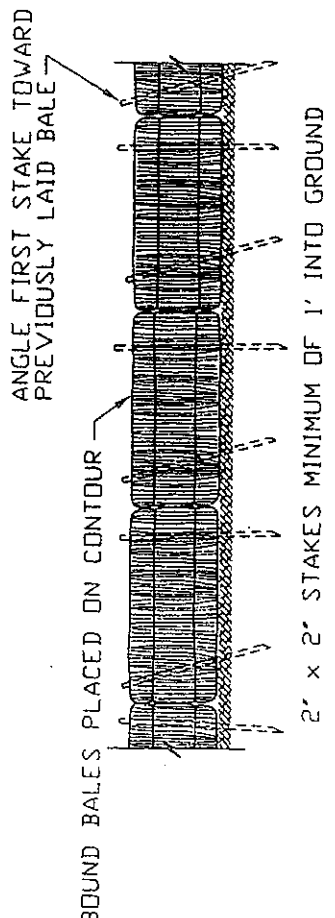

ANCHORING DETAIL

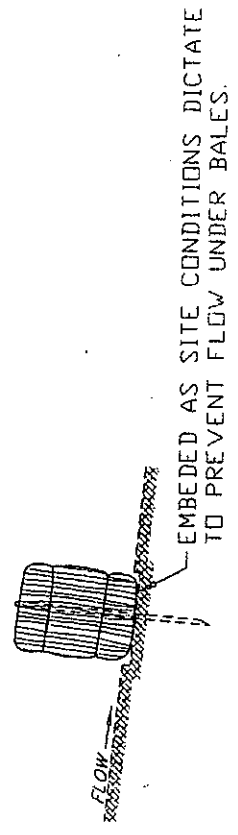

END VIEW

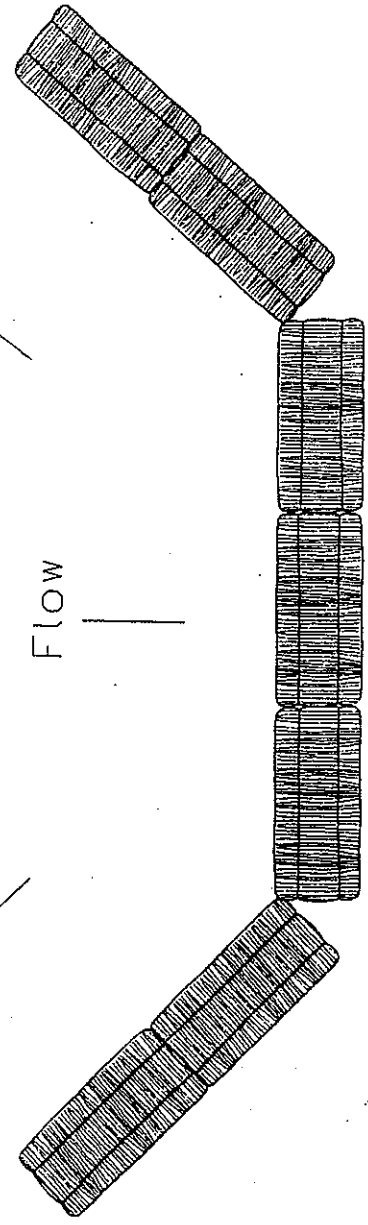

DESIGN TO FIT SITE CONDITIONS

SEDIMENT BARRIER  
TOP VIEW

NOT TO SCALE

BUYER  
CB-23

REQ. or P.O. No.  
DEP15165

SPILL CONTAINMENT

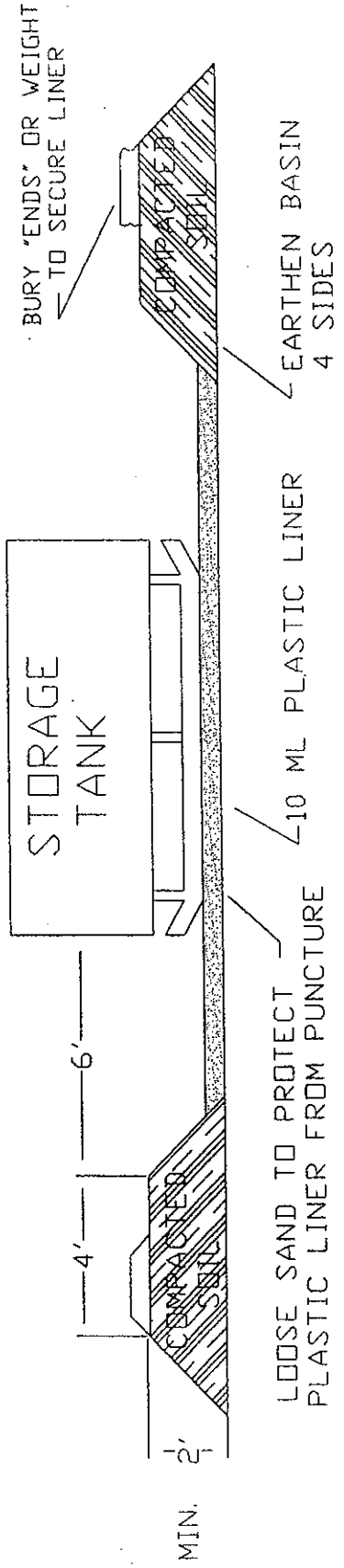

SELECTED HEIGHT OF EARTHEN BERM IS TO BE A TWO (2') FOOT MINIMUM OR ONE HUNDRED TEN PERCENT (110%) OF THE CAPACITY OF THE TANK(S) TOTAL VOLUME WITHIN THE BERM. A SIX (6") INCH FREEBOARD MUST BE INCLUDED.

NOTE: A TWO INCH (2") WATER REMOVAL DRAIN SHALL BE LOCATED AT THE LOWEST POINT IN THE BOTTOM OF THE CONTAINMENT VOLUME. IT SHALL CONNECT TO A NORMALLY CLOSED VALVE OUTSIDE THE DIKE. THE VALVE SHALL BE MANUALLY OPERATED AND PROTECTED FROM UNAUTHORIZED OPERATION. RAINWATER CONTAINED WITHIN THIS DIKE SHALL BE EXAMINED PRIOR TO RELEASE TO ENSURE THAT HARMFUL QUANTITIES OF FUELS AND LUBRICANTS ARE NOT DISCHARGED. ALTERNATE METHODS OF WATER REMOVAL WILL BE CONSIDERED FOR APPROVAL.

TANKS WITH SECONDARY CONTAINMENT MAY BE USED AS AN ALTERNATIVE.



State of West Virginia  
 Department of Administration  
 Purchasing Division  
 2019 Washington Street East  
 Post Office Box 50130  
 Charleston, WV 25305-0130

# Request for Quotation

RFQ NUMBER  
 DEP15165

PAGE  
 1

ADDRESS CORRESPONDENCE TO ATTENTION OF  
 CHUCK BOWMAN  
 304-558-2157

PROCUREMENT

\*B19160306      304-622-2400  
 PRO CONTRACTING INC  
 PO BOX 2442  
  
 CLARKSBURG WV 26301

SHIP TO

ENVIRONMENTAL PROTECTION  
 DEPT. OF  
 OFFICE OF SPECIAL RECLAMATION  
 105 S. RAILROAD STREET  
 PHILIPPI, WV  
 26416-9998      304-457-3219

DATE PRINTED	TERMS OF SALE	SHIP VIA	F.O.B.	FREIGHT TERMS
10/12/2010				

BID OPENING DATE: 10/21/2010      BID OPENING TIME 01:30PM

LINE	QUANTITY	UOP	CAT. NO.	ITEM NUMBER	UNIT PRICE	AMOUNT
				ADDENDUM NO. 1		
				ADDENDUM ISSUED FOR THE MASTELLER COAL CO. PROJECT IN MINERAL CO., WV, TO DISTRIBUTE THE PRE-BID SIGN-IN SHEETS, THE Q/A, AND THE ATTACHED SKETCH RESULTING FROM THE MANDATORY ON-SITE PREBID ON 09/30/2010.  BID OPENING DATE AND TIME REMAIN UNCHANGED AS 10/21/10 AT 1:30 PM.  ***** NO OTHER CHANGES *****		
0001	1	JB		962-73		\$658,805. <sup>00</sup>
				RECLAMATION: RESTORATION OF LAND		

SEE REVERSE SIDE FOR TERMS AND CONDITIONS

SIGNATURE: *[Signature]*      TELEPHONE: 304-622-2400      DATE: 10-20-10

TITLE: Vice President      FEIN: 26-3348227      ADDRESS CHANGES TO BE NOTED ABOVE

WHEN RESPONDING TO RFQ, INSERT NAME AND ADDRESS IN SPACE ABOVE LABELED 'VENDOR'



## AVS OFT Report - 1/5/2010 8:28:04 AM

All OFT's where the selected entity is listed as an entity or related entity

### Entity Selected (248140) Pro Contracting Inc

Parent Entity	Description	Related Entity	% Ownership	Begin Date	End Date
(248140) Pro Contracting Inc	Shareholder	(151167) Matthew Evans	20%	9/18/2008	
(248140) Pro Contracting Inc	Secretary	(151167) Matthew Evans		9/18/2008	
(248140) Pro Contracting Inc	Shareholder	(099850) David B Lang	40%	12/29/2009	
(248140) Pro Contracting Inc	Vice President	(099850) David B Lang		12/29/2009	
(248140) Pro Contracting Inc	Shareholder	(145524) Bryan W Reger	40%	12/29/2009	
(248140) Pro Contracting Inc	President	(145524) Bryan W Reger		9/18/2008	
(248140) Pro Contracting Inc	Shareholder	(145524) Bryan W Reger	80%	9/18/2008	12/29/2009



# CERTIFICATE OF LIABILITY INSURANCE

OP ID SB

DATE (MM/DD/YYYY)

09/29/10

THIS CERTIFICATE IS ISSUED AS A MATTER OF INFORMATION ONLY AND CONFERS NO RIGHTS UPON THE CERTIFICATE HOLDER. THIS CERTIFICATE DOES NOT AFFIRMATIVELY OR NEGATIVELY AMEND, EXTEND OR ALTER THE COVERAGE AFFORDED BY THE POLICIES BELOW. THIS CERTIFICATE OF INSURANCE DOES NOT CONSTITUTE A CONTRACT BETWEEN THE ISSUING INSURER(S), AUTHORIZED REPRESENTATIVE OR PRODUCER, AND THE CERTIFICATE HOLDER.

**IMPORTANT:** If the certificate holder is an **ADDITIONAL INSURED**, the policy(ies) must be endorsed. If **SUBROGATION IS WAIVED**, subject to the terms and conditions of the policy, certain policies may require an endorsement. A statement on this certificate does not confer rights to the certificate holder in lieu of such endorsement(s).

<b>PRODUCER</b>  United Security Agency 139 West Main Street Bridgeport WV 26330 Phone: 304-842-3314 Fax: 304-842-7321	<b>CONTACT NAME:</b> _____	
	<b>PHONE (A/C, No, Ext):</b> _____	<b>FAX (A/C, No):</b> _____
<b>E-MAIL ADDRESS:</b> _____		
<b>PRODUCER CUSTOMER ID #:</b> PROCO-1		
<b>INSURER(S) AFFORDING COVERAGE</b>		<b>NAIC #</b>
<b>INSURED</b>  PRO CONTRACTING INC DAVE LANG P O BOX 2442 CLARKSBURG WV 26302-2442	<b>INSURER A:</b> BRICKSTREET INSURANCE	<b>12372</b>
	<b>INSURER B:</b>	
	<b>INSURER C:</b>	
	<b>INSURER D:</b>	
	<b>INSURER E:</b>	
	<b>INSURER F:</b>	

**COVERAGES**                      **CERTIFICATE NUMBER:**                      **REVISION NUMBER:**

THIS IS TO CERTIFY THAT THE POLICIES OF INSURANCE LISTED BELOW HAVE BEEN ISSUED TO THE INSURED NAMED ABOVE FOR THE POLICY PERIOD INDICATED. NOTWITHSTANDING ANY REQUIREMENT, TERM OR CONDITION OF ANY CONTRACT OR OTHER DOCUMENT WITH RESPECT TO WHICH THIS CERTIFICATE MAY BE ISSUED OR MAY PERTAIN, THE INSURANCE AFFORDED BY THE POLICIES DESCRIBED HEREIN IS SUBJECT TO ALL THE TERMS, EXCLUSIONS AND CONDITIONS OF SUCH POLICIES. LIMITS SHOWN MAY HAVE BEEN REDUCED BY PAID CLAIMS.

INSR LTR	TYPE OF INSURANCE	ADDD INSR	SUBR WVD	POLICY NUMBER	POLICY EFF (MM/DD/YYYY)	POLICY EXP (MM/DD/YYYY)	LIMITS
	<b>GENERAL LIABILITY</b> <input type="checkbox"/> COMMERCIAL GENERAL LIABILITY <input type="checkbox"/> CLAIMS-MADE <input type="checkbox"/> OCCUR  GEN'L AGGREGATE LIMIT APPLIES PER: <input type="checkbox"/> POLICY <input type="checkbox"/> PRO-JECT <input type="checkbox"/> LOC						EACH OCCURRENCE \$ DAMAGE TO RENTED PREMISES (Ea occurrence) \$ MED EXP (Any one person) \$ PERSONAL & ADV INJURY \$ GENERAL AGGREGATE \$ PRODUCTS - COMP/OP AGG \$ \$
	<b>AUTOMOBILE LIABILITY</b> <input type="checkbox"/> ANY AUTO <input type="checkbox"/> ALL OWNED AUTOS <input type="checkbox"/> SCHEDULED AUTOS <input type="checkbox"/> HIRED AUTOS <input type="checkbox"/> NON-OWNED AUTOS						COMBINED SINGLE LIMIT (Ea accident) \$ BODILY INJURY (Per person) \$ BODILY INJURY (Per accident) \$ PROPERTY DAMAGE (Per accident) \$ \$ \$
	<input type="checkbox"/> UMBRELLA LIAB <input type="checkbox"/> OCCUR <input type="checkbox"/> EXCESS LIAB <input type="checkbox"/> CLAIMS-MADE DEDUCTIBLE RETENTION \$						EACH OCCURRENCE \$ AGGREGATE \$ \$ \$
<b>A</b>	<b>WORKERS COMPENSATION AND EMPLOYERS' LIABILITY</b> ANY PROPRIETOR/PARTNER/EXECUTIVE OFFICER/MEMBER EXCLUDED? (Mandatory in NH) If yes, describe under DESCRIPTION OF OPERATIONS below	<input type="checkbox"/> Y <input type="checkbox"/> N <input type="checkbox"/> N/A		WC10211754-03	10/01/10	10/01/11	<input checked="" type="checkbox"/> WC STATUTORY LIMITS <input type="checkbox"/> OTHER E.L. EACH ACCIDENT \$ 100000 E.L. DISEASE - EA EMPLOYEE \$ 100000 E.L. DISEASE - POLICY LIMIT \$ 500000

DESCRIPTION OF OPERATIONS / LOCATIONS / VEHICLES (Attach ACORD 101, Additional Remarks Schedule, if more space is required)

**CERTIFICATE HOLDER****CANCELLATION**

<b>PROCON2</b>  PRO CONTRACTING, INC P.O. BOX 2442 CLARKSBURG WV 25302	SHOULD ANY OF THE ABOVE DESCRIBED POLICIES BE CANCELLED BEFORE THE EXPIRATION DATE THEREOF, NOTICE WILL BE DELIVERED IN ACCORDANCE WITH THE POLICY PROVISIONS.  AUTHORIZED REPRESENTATIVE <i>Sharon Bayles</i>
--	---

© 1988-2009 ACORD CORPORATION. All rights reserved.

# CONTRACTOR LICENSE

Authorized by the

**West Virginia Contractor Licensing Board**

**Number:** WV044670

**Classification:**

GENERAL ENGINEERING

PRO CONTRACTING INC  
DBA PRO CONTRACTING INC  
PO BOX 2442  
CLARKSBURG, WV 26301

**Date Issued**

OCTOBER 06, 2010

**Expiration Date**

OCTOBER 06, 2011

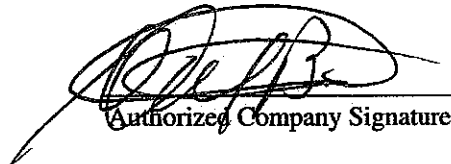
  
Authorized Company Signature

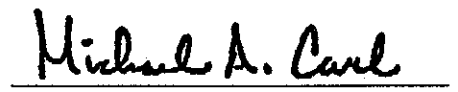
  
Chair, West Virginia Contractor  
Licensing Board

**WEST VIRGINIA  
CONTRACTOR  
LICENSING  
BOARD**

This license, or a copy thereof, must be posted in a conspicuous place at every construction site where work is being performed. This license number must appear in all advertisements, on all bid submissions and on all fully executed and binding contracts. This license cannot be assigned or transferred by licensee. Issued under provisions of West Virginia Code, Chapter 21, Article 11.



**BID BOND**

KNOW ALL MEN BY THESE PRESENTS, That we, the undersigned, Pro Contracting, Inc.  
of P. O. Box 2442, Clarksburg, WV 26302, as Principal, and Travelers Casualty and Surety Company  
of America of 1 Tower Sq., 5PB, Hartford, CT, a corporation organized and existing under the laws of the State of Connecticut  
with its principal office in the City of Hartford, as Surety, are held and firmly bound unto the State  
of West Virginia, as Obligee, in the penal sum of Five Percent of the total amount bid (\$ 5%) for the payment of which,  
well and truly to be made, we jointly and severally bind ourselves, our heirs, administrators, executors, successors and assigns.

The Condition of the above obligation is such that whereas the Principal has submitted to the Purchasing Section of the  
Department of Administration a certain bid or proposal, attached hereto and made a part hereof, to enter into a contract in writing for  
DEP 15165: Reclamation Work - 29.0 Acres  
Piedmont, WV - Mineral County

**NOW THEREFORE,**

- (a) If said bid shall be rejected, or
- (b) If said bid shall be accepted and the Principal shall enter into a contract in accordance with the bid or proposal attached  
hereto and shall furnish any other bonds and insurance required by the bid or proposal, and shall in all other respects perform the  
agreement created by the acceptance of said bid, then this obligation shall be null and void, otherwise this obligation shall remain in full  
force and effect. It is expressly understood and agreed that the liability of the Surety for any and all claims hereunder shall, in no event,  
exceed the penal amount of this obligation as herein stated.

The Surety, for the value received, hereby stipulates and agrees that the obligations of said Surety and its bond shall be in no  
way impaired or affected by any extension of the time within which the Obligee may accept such bid, and said Surety does hereby  
waive notice of any such extension.

IN WITNESS WHEREOF, Principal and Surety have hereunto set their hands and seals, and such of them as are corporations  
have caused their corporate seals to be affixed hereunto and these presents to be signed by their proper officers, this  
21st day of October, 2010.

Principal Corporate Seal

Pro Contracting, Inc.

(Name of Principal)

By 

(Must be President or  
Vice President)

Vice President

(Title)

Surety Corporate Seal

Travelers Casualty and Surety Company of America

(Name of Surety)

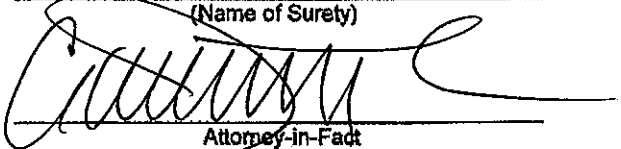
  
Attorney-in-Fact

**IMPORTANT – Surety executing bonds must be licensed in West Virginia to transact surety insurance. Raised corporate seals  
must be affixed, a power of attorney must be attached.**



POWER OF ATTORNEY

Farmington Casualty Company
Fidelity and Guaranty Insurance Company
Fidelity and Guaranty Insurance Underwriters, Inc.
St. Paul Fire and Marine Insurance Company
St. Paul Guardian Insurance Company

St. Paul Mercury Insurance Company
Travelers Casualty and Surety Company
Travelers Casualty and Surety Company of America
United States Fidelity and Guaranty Company

Attorney-In Fact No. 218346

Certificate No. 003280254

KNOW ALL MEN BY THESE PRESENTS: That St. Paul Fire and Marine Insurance Company, St. Paul Guardian Insurance Company and St. Paul Mercury Insurance Company are corporations duly organized under the laws of the State of Minnesota, that Farmington Casualty Company, Travelers Casualty and Surety Company, and Travelers Casualty and Surety Company of America are corporations duly organized under the laws of the State of Connecticut, that United States Fidelity and Guaranty Company is a corporation duly organized under the laws of the State of Maryland, that Fidelity and Guaranty Insurance Company is a corporation duly organized under the laws of the State of Iowa, and that Fidelity and Guaranty Insurance Underwriters, Inc., is a corporation duly organized under the laws of the State of Wisconsin (herein collectively called the "Companies"), and that the Companies do hereby make, constitute and appoint

C. David Thomas, Richard L. Higginbotham, Bunnie Marie Perrine, Jeffery O'Dell, and Robin Hubbard-Sherrod

of the City of Charleston, State of West Virginia, their true and lawful Attorney(s)-in-Fact, each in their separate capacity if more than one is named above, to sign, execute, seal and acknowledge any and all bonds, recognizances, conditional undertakings and other writings obligatory in the nature thereof on behalf of the Companies in their business of guaranteeing the fidelity of persons, guaranteeing the performance of contracts and executing or guaranteeing bonds and undertakings required or permitted in any actions or proceedings allowed by law.

IN WITNESS WHEREOF, the Companies have caused this instrument to be signed and their corporate seals to be hereto affixed, this 5th day of October, 2009.

Farmington Casualty Company
Fidelity and Guaranty Insurance Company
Fidelity and Guaranty Insurance Underwriters, Inc.
St. Paul Fire and Marine Insurance Company
St. Paul Guardian Insurance Company

St. Paul Mercury Insurance Company
Travelers Casualty and Surety Company
Travelers Casualty and Surety Company of America
United States Fidelity and Guaranty Company



State of Connecticut
City of Hartford ss.

By: [Signature]
George W. Thompson, Senior Vice President

On this the 5th day of October, 2009, before me personally appeared George W. Thompson, who acknowledged himself to be the Senior Vice President of Farmington Casualty Company, Fidelity and Guaranty Insurance Company, Fidelity and Guaranty Insurance Underwriters, Inc., St. Paul Fire and Marine Insurance Company, St. Paul Guardian Insurance Company, St. Paul Mercury Insurance Company, Travelers Casualty and Surety Company, Travelers Casualty and Surety Company of America, and United States Fidelity and Guaranty Company, and that he, as such, being authorized so to do, executed the foregoing instrument for the purposes therein contained by signing on behalf of the corporations by himself as a duly authorized officer.

In Witness Whereof, I hereunto set my hand and official seal. My Commission expires the 30th day of June, 2011.



[Signature]
Marie C. Tetreault, Notary Public

This Power of Attorney is granted under and by the authority of the following resolutions adopted by the Boards of Directors of Farmington Casualty Company, Fidelity and Guaranty Insurance Company, Fidelity and Guaranty Insurance Underwriters, Inc., St. Paul Fire and Marine Insurance Company, St. Paul Guardian Insurance Company, St. Paul Mercury Insurance Company, Travelers Casualty and Surety Company, Travelers Casualty and Surety Company of America, and United States Fidelity and Guaranty Company, which resolutions are now in full force and effect, reading as follows:

**RESOLVED**, that the Chairman, the President, any Vice Chairman, any Executive Vice President, any Senior Vice President, any Vice President, any Second Vice President, the Treasurer, any Assistant Treasurer, the Corporate Secretary or any Assistant Secretary may appoint Attorneys-in-Fact and Agents to act for and on behalf of the Company and may give such appointee such authority as his or her certificate of authority may prescribe to sign with the Company's name and seal with the Company's seal bonds, recognizances, contracts of indemnity, and other writings obligatory in the nature of a bond, recognizance, or conditional undertaking, and any of said officers or the Board of Directors at any time may remove any such appointee and revoke the power given him or her; and it is

**FURTHER RESOLVED**, that the Chairman, the President, any Vice Chairman, any Executive Vice President, any Senior Vice President or any Vice President may delegate all or any part of the foregoing authority to one or more officers or employees of this Company, provided that each such delegation is in writing and a copy thereof is filed in the office of the Secretary; and it is

**FURTHER RESOLVED**, that any bond, recognizance, contract of indemnity, or writing obligatory in the nature of a bond, recognizance, or conditional undertaking shall be valid and binding upon the Company when (a) signed by the President, any Vice Chairman, any Executive Vice President, any Senior Vice President or any Vice President, any Second Vice President, the Treasurer, any Assistant Treasurer, the Corporate Secretary or any Assistant Secretary and duly attested and sealed with the Company's seal by a Secretary or Assistant Secretary; or (b) duly executed (under seal, if required) by one or more Attorneys-in-Fact and Agents pursuant to the power prescribed in his or her certificate or their certificates of authority or by one or more Company officers pursuant to a written delegation of authority; and it is

**FURTHER RESOLVED**, that the signature of each of the following officers: President, any Executive Vice President, any Senior Vice President, any Vice President, any Assistant Vice President, any Secretary, any Assistant Secretary, and the seal of the Company may be affixed by facsimile to any Power of Attorney or to any certificate relating thereto appointing Resident Vice Presidents, Resident Assistant Secretaries or Attorneys-in-Fact for purposes only of executing and attesting bonds and undertakings and other writings obligatory in the nature thereof, and any such Power of Attorney or certificate bearing such facsimile signature or facsimile seal shall be valid and binding upon the Company and any such power so executed and certified by such facsimile signature and facsimile seal shall be valid and binding on the Company in the future with respect to any bond or understanding to which it is attached.

I, Kori M. Johanson, the undersigned, Assistant Secretary, of Farmington Casualty Company, Fidelity and Guaranty Insurance Company, Fidelity and Guaranty Insurance Underwriters, Inc., St. Paul Fire and Marine Insurance Company, St. Paul Guardian Insurance Company, St. Paul Mercury Insurance Company, Travelers Casualty and Surety Company, Travelers Casualty and Surety Company of America, and United States Fidelity and Guaranty Company do hereby certify that the above and foregoing is a true and correct copy of the Power of Attorney executed by said Companies, which is in full force and effect and has not been revoked.

IN TESTIMONY WHEREOF, I have hereunto set my hand and affixed the seals of said Companies this 22<sup>nd</sup> day of October, 20 10.

WARNING: THIS POWER OF ATTORNEY IS INVALID WITHOUT THE RED BORDER

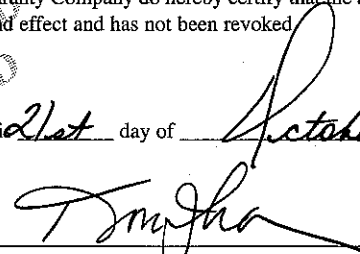
  
Kori M. Johanson, Assistant Secretary



To verify the authenticity of this Power of Attorney, call 1-800-421-3880 or contact us at [www.travelersbond.com](http://www.travelersbond.com). Please refer to the Attorney-In-Fact number, the above-named individuals and the details of the bond to which the power is attached.



State of West Virginia  
DRUG FREE WORKPLACE CONFORMANCE AFFIDAVIT  
West Virginia Code §21-1D-5

STATE OF West Virginia

COUNTY OF Harrison, TO-WIT:

I, Steve J. Szabo, after being first duly sworn, depose and state as follows:

- 1. I am an employee of Pro Contracting, Inc.; and,  
(Company Name)
- 2. I do hereby attest that Pro Contracting, Inc.  
(Company Name)

maintains a valid written drug free workplace policy and that such policy is in compliance with **West Virginia Code §21-1D-5**.

The above statements are sworn to under the penalty of perjury.

Pro Contracting, Inc.  
(Company Name)

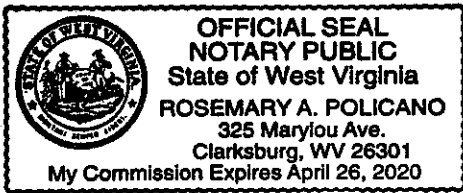

By: Steve J. Szabo

Title: Estimator

Date: 10/20/2010

Taken, subscribed and sworn to before me this 20 day of October 2010.

By Commission expires April 26, 2020

(Seal)

Rosemary Policano  
(Notary Public)

**THIS AFFIDAVIT MUST BE SUBMITTED WITH THE BID IN ORDER TO COMPLY WITH WV CODE PROVISIONS. FAILURE TO INCLUDE THE AFFIDAVIT WITH THE BID SHALL RESULT IN DISQUALIFICATION OF THE BID.**

RFQ No. DP 15165

STATE OF WEST VIRGINIA  
Purchasing Division

**PURCHASING AFFIDAVIT**

West Virginia Code §5A-3-10a states: No contract or renewal of any contract may be awarded by the state or any of its political subdivisions to any vendor or prospective vendor when the vendor or prospective vendor or a related party to the vendor or prospective vendor is a debtor and the debt owned is an amount greater than one thousand dollars in the aggregate

**DEFINITIONS:**

"Debt" means any assessment, premium, penalty, fine, tax or other amount of money owed to the state or any of its political subdivisions because of a judgment, fine, permit violation, license assessment, defaulted workers' compensation premium, penalty or other assessment presently delinquent or due and required to be paid to the state or any of its political subdivisions, including any interest or additional penalties accrued thereon.

"Debtor" means any individual, corporation, partnership, association, Limited Liability Company or any other form or business association owing a debt to the state or any of its political subdivisions. "Political subdivision" means any county commission; municipality; county board of education; any instrumentality established by a county or municipality; any separate corporation or instrumentality established by one or more counties or municipalities, as permitted by law; or any public body charged by law with the performance of a government function or whose jurisdiction is coextensive with one or more counties or municipalities. "Related party" means a party, whether an individual, corporation, partnership, association, limited liability company or any other form or business association or other entity whatsoever, related to any vendor by blood, marriage, ownership or contract through which the party has a relationship of ownership or other interest with the vendor so that the party will actually or by effect receive or control a portion of the benefit, profit or other consideration from performance of a vendor contract with the party receiving an amount that meets or exceeds five percent of the total contract amount.

**EXCEPTION:** The prohibition of this section does not apply where a vendor has contested any tax administered pursuant to chapter eleven of this code, workers' compensation premium, permit fee or environmental fee or assessment and the matter has not become final or where the vendor has entered into a payment plan or agreement and the vendor is not in default of any of the provisions of such plan or agreement.

Under penalty of law for false swearing (*West Virginia Code* §61-5-3), it is hereby certified that the vendor affirms and acknowledges the information in this affidavit and is in compliance with the requirements as stated.

**WITNESS THE FOLLOWING SIGNATURE**

Vendor's Name: Pro Contracting, Inc.

Authorized Signature: [Signature] Date: 10-20-10

State of West Virginia

County of Harrison, to-wit:

Taken, subscribed, and sworn to before me this 20 day of October, 2010.

My Commission expires April 26, 2020, 20  .

AFFIX SEAL HERE

NOTARY PUBLIC

[Signature: Rosemary Policano]

