



State of West Virginia
 Department of Administration
 Purchasing Division
 2019 Washington Street East
 Post Office Box 50130
 Charleston, WV 25305-0130

Request for Quotation

RFQ NUMBER
DEP14397

PAGE
1

ADDRESS CORRESPONDENCE TO ATTENTION OF:
CHUCK BOWMAN 304-558-2157

VENDOR
 *709060417 304-984-1115
 CARPENTER RECLAMATION INC
 PO BOX 13015
 SISSONVILLE WV 25360-0015

SHIP TO
 ENVIRONMENTAL PROTECTION
 DEPT. OF
 OFFICE OF SPECIAL RECLAMATION
 601 57TH STREET SE
 CHARLESTON, WV
 25304 304-926-0499

DATE PRINTED	TERMS OF SALE	SHIP VIA	F.O.B.	FREIGHT TERMS
05/24/2010				

BID OPENING DATE: 07/14/2010	BID OPENING TIME: 01:30PM
------------------------------	---------------------------

LINE	QUANTITY	UOP	CAT NO	ITEM NUMBER	UNIT PRICE	AMOUNT
0001	1	JB		962-73		
RECLAMATION: RESTORATION OF LAND THE WEST VIRGINIA PURCHASING DIVISION, FOR THE THE AGENCY, THE WEST VIRGINIA DEPARTMENT OF ENVIRONMENTAL PROTECTION, IS SOLICITING BIDS FROM QUALIFIED CONTRACTORS FOR A CONTRACT TO PROVIDE ALL LABOR AND MATERIALS TO PERFORM RECLAMATION ON THE MINING OPERATION OF PRINCESS SUSAN COAL COMPANY UNDER REVOKED PERMIT NUMBER(S) S-6-85 ON A SITE OF APPROXIMATELY 25 ACRES LOCATED NEAR CEDAR GROVE, WEST VIRGINIA, (KANAWHA CO.). THE RECLAMATION SHALL BE PERFORMED UNDER THE GUIDANCE AND GENERAL SUPERVISION OF THE AGENT ASSIGNED TO THE PROJECT FOR THE STATE OF WEST VIRGINIA, DEPARTMENT OF ENVIRONMENTAL PROTECTION. A MANDATORY ON-SITE PREBID CONFERENCE SHALL BE HELD ON 06/16/2010 @ 10:00 AM. ALL INTERESTED PARTIES ARE REQUIRED TO ATTEND THIS MEETING. FAILURE TO ATTEND THE MANDATORY PRE-BID SHALL RESULT IN DISQUALIFICATION OF THE BID. NO ONE PERSON MAY REPRESENT MORE THAN ONE BIDDER. AN ATTENDANCE SHEET WILL BE MADE AVAILABLE FOR ALL POTENTIAL BIDDERS TO COMPLETE. THIS WILL SERVE AS THE OFFICIAL DOCUMENT VERIFYING ATTENDANCE AT THE MANDATORY PRE-BID. FAILURE TO PROVIDE YOUR COMPANY AND REPRESENTATIVE NAME ON THE ATTENDANCE SHEET WILL RESULT IN DISQUALIFICATION OF THE BID. THE STATE WILL NOT ACCEPT ANY OTHER DOCUMENTATION TO VERIFY ATTENDANCE. THE BIDDER IS RESPONSIBLE FOR ENSURING THEY HAVE COMPLETED THE INFOR						ADDENDUMS (1+2) \$ 661,101.00

RECEIVED
 2010 JUL 29 AM 8:45
 WV PURCHASING DIVISION

SEE REVERSE SIDE FOR TERMS AND CONDITIONS			
SIGNATURE <i>Kelley Carpenter</i>	TELEPHONE 304 984 1115	DATE 7-29-10	
TITLE <i>President</i>	FEIN 55-0693493	ADDRESS CHANGES TO BE NOTED ABOVE	

WHEN RESPONDING TO RFQ, INSERT NAME AND ADDRESS IN SPACE ABOVE LABELED 'VENDOR'

GENERAL TERMS & CONDITIONS REQUEST FOR QUOTATION (RFQ) AND REQUEST FOR PROPOSAL (RFP)

1. Awards will be made in the best interest of the State of West Virginia.
2. The State may accept or reject in part, or in whole, any bid.
3. Prior to any award, the apparent successful vendor must be properly registered with the Purchasing Division and have paid the required \$125 fee.
4. All services performed or goods delivered under State Purchase Order/Contracts are to be continued for the term of the Purchase Order/Contracts, contingent upon funds being appropriated by the Legislature or otherwise being made available. In the event funds are not appropriated or otherwise available for these services or goods this Purchase Order/Contract becomes void and of no effect after June 30.
5. Payment may only be made after the delivery and acceptance of goods or services.
6. Interest may be paid for late payment in accordance with the *West Virginia Code*.
7. Vendor preference will be granted upon written request in accordance with the *West Virginia Code*.
8. The State of West Virginia is exempt from federal and state taxes and will not pay or reimburse such taxes.
9. The Director of Purchasing may cancel any Purchase Order/Contract upon 30 days written notice to the seller.
10. The laws of the State of West Virginia and the *Legislative Rules* of the Purchasing Division shall govern the purchasing process.
11. Any reference to automatic renewal is hereby deleted. The Contract may be renewed only upon mutual written agreement of the parties.
12. **BANKRUPTCY:** In the event the vendor/contractor files for bankruptcy protection, the State may deem this contract null and void, and terminate such contract without further order.
13. **HIPAA BUSINESS ASSOCIATE ADDENDUM:** The West Virginia State Government HIPAA Business Associate Addendum (BAA), approved by the Attorney General, is available online at www.state.wv.us/admin/purchase/vrc/hipaa.htm and is hereby made part of the agreement. Provided that the Agency meets the definition of a Cover Entity (45 CFR §160.103) and will be disclosing Protected Health Information (45 CFR §160.103) to the vendor.
14. **CONFIDENTIALITY:** The vendor agrees that he or she will not disclose to anyone, directly or indirectly, any such personally identifiable information or other confidential information gained from the agency, unless the individual who is the subject of the information consents to the disclosure in writing or the disclosure is made pursuant to the agency's policies, procedures, and rules. Vendor further agrees to comply with the Confidentiality Policies and Information Security Accountability Requirements, set forth in <http://www.state.wv.us/admin/purchase/privacy/noticeConfidentiality.pdf>.
15. **LICENSING:** Vendors must be licensed and in good standing in accordance with any and all state and local laws and requirements by any state or local agency of West Virginia, including, but not limited to, the West Virginia Secretary of State's Office, the West Virginia Tax Department, and the West Virginia Insurance Commission. The vendor must provide all necessary releases to obtain information to enable the director or spending unit to verify that the vendor is licensed and in good standing with the above entities.
16. **ANTITRUST:** In submitting a bid to any agency for the State of West Virginia, the bidder offers and agrees that if the bid is accepted the bidder will convey, sell, assign or transfer to the State of West Virginia all rights, title and interest in and to all causes of action it may now or hereafter acquire under the antitrust laws of the United States and the State of West Virginia for price fixing and/or unreasonable restraints of trade relating to the particular commodities or services purchased or acquired by the State of West Virginia. Such assignment shall be made and become effective at the time the purchasing agency tenders the initial payment to the bidder.

I certify that this bid is made without prior understanding, agreement, or connection with any corporation, firm, limited liability company, partnership, or person or entity submitting a bid for the same material, supplies, equipment or services and is in all respects fair and without collusion or Fraud. I further certify that I am authorized to sign the certification on behalf of the bidder or this bid.

INSTRUCTIONS TO BIDDERS

1. Use the quotation forms provided by the Purchasing Division. Complete all sections of the quotation form.
2. Items offered must be in compliance with the specifications. Any deviation from the specifications must be clearly indicated by the bidder. Alternates offered by the bidder as **EQUAL** to the specifications must be clearly defined. A bidder offering an alternate should attach complete specifications and literature to the bid. The Purchasing Division may waive minor deviations to specifications.
3. Unit prices shall prevail in case of discrepancy. All quotations are considered F.O.B. destination unless alternate shipping terms are clearly identified in the quotation.
4. All quotations must be delivered by the bidder to the office listed below prior to the date and time of the bid opening. Failure of the bidder to deliver the quotations on time will result in bid disqualifications: Department of Administration, Purchasing Division, 2019 Washington Street East, P.O. Box 50130, Charleston, WV 25305-0130
5. Communication during the solicitation, bid, evaluation or award periods, except through the Purchasing Division, is strictly prohibited (W.Va. C.S.R. §148-1-6.6).



State of West Virginia
 Department of Administration
 Purchasing Division
 2019 Washington Street East
 Post Office Box 50130
 Charleston, WV 25305-0130

Request for Quotation

RFQ NUMBER
 DEP14397

PAGE
 2

ADDRESS CORRESPONDENCE TO ATTENTION OF
 CHUCK BOWMAN
 304-558-2157

*709060417 304-984-1115
 CARPENTER RECLAMATION INC
 PO BOX 13015
 SISSONVILLE WV 25360-0015

ENVIRONMENTAL PROTECTION
 DEPT. OF
 OFFICE OF SPECIAL RECLAMATION
 601 57TH STREET SE
 CHARLESTON, WV
 25304 304-926-0499

DATE PRINTED	TERMS OF SALE	SHIP VIA	FOB	FREIGHT TERMS
05/24/2010				

BID OPENING DATE: 07/14/2010 BID OPENING TIME 01:30PM

LINE	QUANTITY	UOP	CAT. NO.	ITEM NUMBER	UNIT PRICE	AMOUNT
<p>MATION REQUIRED ON THE ATTENDANCE SHEET. THE PURCHASING DIVISION AND THE STATE AGENCY WILL NOT ASSUME ANY RESPONSIBILITY FOR A BIDDER'S FAILURE TO COMPLETE THE PRE-BID ATTENDANCE SHEET. IN ADDITION, WE REQUEST THAT ALL POTENTIAL BIDDERS INCLUDE THEIR E-MAIL ADDRESS AND FAX NUMBER.</p> <p>ALL POTENTIAL BIDDERS ARE REQUESTED TO ARRIVE PRIOR TO THE STARTING TIME FOR THE PRE-BID. BIDDERS WHO ARRIVE LATE, BUT PRIOR TO THE DISMISSAL OF THE TECHNICAL PORTION OF THE PRE-BID WILL BE PERMITTED TO SIGN IN. BIDDERS WHO ARRIVE AFTER CONCLUSION OF THE TECHNICAL PORTION OF THE PRE-BID, BUT DURING ANY SUBSEQUENT PART OF THE PRE-BID WILL NOT BE PERMITTED TO SIGN THE ATTENDANCE SHEET.</p> <p>DIRECTIONS TO PRE-BID: AT CEDAR GROVE, WV, TURN ONTO KELLY'S CREEK ROAD (COUNTY ROAD 81/12) TRAVEL ABOUT 1 MILE ON CR 81/12 AND TURN LEFT AT THE WARD CEMETERY. FOLLOW ROAD PAST CEMETERY GATES AND UP HILL TO MINE SITE. MINE SITE IS AT THE TOP OF THE HILL</p> <p>ALL WORK MUST BE COMPLETED IN ACCORDANCE WITH THE PLANS AND SPECIFICATIONS PREPARED BY THE DEPARTMENT OF ENVIRONMENTAL PROTECTION AND PURCHASE ORDER ISSUED BY THE DEPARTMENT OF ADMINISTRATION, DIVISION OF PURCHASING.</p> <p>EXHIBIT 5</p> <p>WEST VIRGINIA CODE 21-1D-5 PROVIDES THAT: ANY SOLICITATION FOR A PUBLIC IMPROVEMENT CONSTRUCTION CONTRACT REQUIRES EACH VENDOR THAT SUBMITS A BID FOR THE WORK TO SUBMIT AT THE SAME TIME AN AFFIDAVIT OF COMPLIANCE WITH THE BID. THE ENCLOSED DRUG FREE WORK PLACE AFFIDAVIT MUST BE SIGNED & SUBMITTED WITH THE BID AS EVIDENCE OF THE VENDOR'S COMPLIANCE WITH THE PROVISIONS OF ARTICLE 1D, CHAPTER 21 OF THE WV CODE. FAILURE TO SUBMIT THE</p>						

SEE REVERSE SIDE FOR TERMS AND CONDITIONS

SIGNATURE	TELEPHONE	DATE
TITLE	FEIN	ADDRESS CHANGES TO BE NOTED ABOVE

WHEN RESPONDING TO RFQ, INSERT NAME AND ADDRESS IN SPACE ABOVE LABELLED 'VENDOR'



State of West Virginia
 Department of Administration
 Purchasing Division
 2019 Washington Street East
 Post Office Box 50130
 Charleston, WV 25305-0130

Request for Quotation

RFO NUMBER
 DEP14397

PAGE
 3

ADDRESS CORRESPONDENCE TO ATTENTION OF
 CHUCK BOWMAN
 304-558-2157

VENDOR

*709060417 304-984-1115
 CARPENTER RECLAMATION INC
 PO BOX 13015
 SISSONVILLE WV 25360-0015

SHIP TO

ENVIRONMENTAL PROTECTION
 DEPT. OF
 OFFICE OF SPECIAL RECLAMATION
 601 57TH STREET SE
 CHARLESTON, WV
 25304 304-926-0499

DATE PRINTED	TERMS OF SALE	SHIP VIA	F.O.B.	FREIGHT TERMS
05/24/2010				

BID OPENING DATE: 07/14/2010 BID OPENING TIME 01:30PM

LINE	QUANTITY	UOP	CAT NO	ITEM NUMBER	UNIT PRICE	AMOUNT
<p>SIGNED PURCHASING AFFIDAVIT WITH THE BID SHALL RESULT IN DISQUALIFICATION OF SUCH BID.</p> <p>NOTICE TO PROCEED: THIS CONTRACT IS TO BE PERFORMED WITH 365 CALENDAR DAYS AFTER THE NOTICE TO PROCEED IS RECEIVED. UNLESS OTHERWISE SPECIFIED, THE FULLY EXECUTED PURCHASE ORDER WILL BE CONSIDERED NOTICE TO PROCEED.</p> <p>CANCELLATION: THE DIRECTOR OF PURCHASING RESERVES THE RIGHT TO CANCEL THIS CONTRACT IMMEDIATELY UPON WRITTEN NOTICE TO THE VENDOR IF THE MATERIALS OR WORKMANSHIP SUPPLIED ARE OF AN INFERIOR QUALITY OR DO NOT CONFORM WITH THE SPECIFICATIONS OF THE THE BID AND CONTRACT HERE IN.</p> <p>WAGE RATES: THE CONTRACTOR OR SUBCONTRACTOR SHALL PAY THE HIGHER OF THE U.S. DEPARTMENT OF LABOR MINIMUM WAG RATES AS ESTABLISHED FOR KANAWHA COUNTY, PURSUANT TO WEST VIRGINIA CODE 21-5A, ET, SEQ. (PREVAILING WAGE RATES APPLY TO THIS PROJECT)</p> <p>ARBITRATION: ANY REFERENCES MADE TO ARBITRATION OR INTEREST FOR PAYMENTS DUE (EXCEPT FOR ANY INTEREST REQUIRED BY STATE LAW) CONTAINED IN THIS CONTRACT OR IN ANY AMERICAN INSTITUTE OF ARCHITECTS DOCUMENTS PERTAINING TO THIS CONTRACT ARE HEREBY DELETED.</p> <p>WORKERS' COMPENSATION: VENDOR IS REQUIRED TO PROVIDE A CERTIFICATE FROM WORKERS' COMPENSATION IF SUCCESSFUL</p> <p>ALL OF THE ITEMS CHECKED BELOW WILL BE A REQUIREMENT OF THIS CONTRACT:</p> <p>(XX) INSURANCE: SUCCESSFUL VENDOR SHALL FURNISH PROOF OF COMMERCIAL GENERAL LIABILITY INSURANCE PRIOR TO</p>						

SEE REVERSE SIDE FOR TERMS AND CONDITIONS

SIGNATURE	TELEPHONE	DATE
TITLE	FEIN	ADDRESS CHANGES TO BE NOTED ABOVE

WHEN RESPONDING TO RFO, INSERT NAME AND ADDRESS IN SPACE ABOVE LABELED 'VENDOR'



State of West Virginia
 Department of Administration
 Purchasing Division
 2019 Washington Street East
 Post Office Box 50130
 Charleston, WV 25305-0130

Request for Quotation

REQ NUMBER
DEP14397

PAGE
4

ADDRESS CORRESPONDENCE TO ATTENTION OF
CHUCK BOWMAN 304-558-2157

VENDOR

*709060417 304-984-1115
 CARPENTER RECLAMATION INC
 PO BOX 13015
 SISSONVILLE WV 25360-0015

SHIP TO

ENVIRONMENTAL PROTECTION
 DEPT. OF
 OFFICE OF SPECIAL RECLAMATION
 601 57TH STREET SE
 CHARLESTON, WV
 25304 304-926-0499

DATE PRINTED	TERMS OF SALE	SHIP VIA	F.O.B.	FREIGHT TERMS
05/24/2010				

BID OPENING DATE:

07/14/2010

BID OPENING TIME 01:30PM

LINE	QUANTITY	UOP	CAT NO.	ITEM NUMBER	UNIT PRICE	AMOUNT
<p>ISSUANCE OF CONTRACT. UNLESS OTHERWISE SPECIFIED IN THE BID DOCUMENTS, THE MINIMUM AMOUNT OF INSURANCE COVERAGE REQUIRED IS \$250,000.</p> <p>() BUILDERS RISK INSURANCE: SUCCESSFUL VENDOR SHALL FURNISH PROOF OF BUILDERS RISK - ALL RISK INSURANCE IN AN AMOUNT EQUAL TO 100% OF THE AMOUNT OF THE CONTRACT.</p> <p>(XX) BONDS: FIVE PERCENT (5%) OF THE TOTAL AMOUNT OF THE BID PAYABLE TO THE STATE OF WEST VIRGINIA, SHALL BE SUBMITTED WITH EACH BID AS A BID BOND. THE SUCCESSFUL BIDDER SHALL ALSO FURNISH A PERFORMANCE BOND AND LABOR/MATERIAL BOND FOR 100% OF THE AMOUNT OF THE CONTRACT. BONDS MAY BE PROVIDED IN THE FORM OF A CERTIFIED CHECK, IRREVOCABLE LETTER OF CREDIT, OR BOND FURNISHED BY A SOLVENT SURETY COMPANY AUTHORIZED TO DO BUSINESS IN THE STATE OF WEST VIRGINIA. A LETTER OF CREDIT SUBMITTED IN LIEU OF A BOND WILL ONLY BE ALLOWED FOR PROJECTS UNDER \$100,000. PERSONAL OR BUSINESS CHECKS ARE NOT ACCEPTABLE IN LIEU OF THE 5% BID BOND, PERFORMANCE BOND, OR LABOR AND MATERIAL BOND.</p> <p>() MAINTENANCE BOND: A TWO (2) YEAR MAINTENANCE BOND COVERING THE ROOFING SYSTEM WILL BE A REQUIREMENT OF THE SUCCESSFUL VENDOR.</p> <p>REV. 11/00</p> <p>CONTRACTORS LICENSE</p> <p>WEST VIRGINIA STATE CODE 21-11-2 REQUIRES THAT ALL PERSONS DESIRING TO PERFORM CONTRACTING WORK IN THIS STATE MUST BE LICENSED. THE WEST VIRGINIA CONTRACTORS LICENSING BOARD IS EMPOWERED TO ISSUE THE CONTRACTORS LICENSE. APPLICATIONS FOR A CONTRACTORS LICENSE MAY B</p>						

SEE REVERSE SIDE FOR TERMS AND CONDITIONS

SIGNATURE	TELEPHONE	DATE
-----------	-----------	------

TITLE	FEIN	ADDRESS CHANGES TO BE NOTED ABOVE
-------	------	-----------------------------------

WHEN RESPONDING TO REQ INSERT NAME AND ADDRESS IN SPACE ABOVE LABELLED 'VENDOR'



State of West Virginia
 Department of Administration
 Purchasing Division
 2019 Washington Street East
 Post Office Box 50130
 Charleston, WV 25305-0130

Request for Quotation

RFQ NUMBER
 DEP14397

PAGE
 5

ADDRESS CORRESPONDENCE TO ATTENTION OF
 CHUCK BOWMAN
 304-558-2157

VENDOR
 *709060417 304-984-1115
 CARPENTER RECLAMATION INC
 PO BOX 13015
 SISSONVILLE WV 25360-0015

SHIP TO
 ENVIRONMENTAL PROTECTION
 DEPT. OF
 OFFICE OF SPECIAL RECLAMATION
 601 57TH STREET SE
 CHARLESTON, WV
 25304 304-926-0499

DATE PRINTED	TERMS OF SALE	SHIP VIA	F.O.B.	FREIGHT TERMS
05/24/2010				

BID OPENING DATE: 07/14/2010 BID OPENING TIME 01:30PM

LINE	QUANTITY	UOP	CAT NO	ITEM NUMBER	UNIT PRICE	AMOUNT
<p>MADE BY CONTACTING THE WEST VIRGINIA DIVISION OF LABOR CAPITOL COMPLEX, BUILDING 3, ROOM 319, CHARLESTON, WV 25305. TELEPHONE: (304) 558-7890.</p> <p>WEST VIRGINIA STATE CODE 21-11-11 REQUIRES ANY PROSPECTIVE BIDDER TO INCLUDE THE CONTRACTORS LICENSE NUMBER ON THEIR BID.</p> <p>BIDDER TO COMPLETE CONTRACTORS NAME: <i>Carpenter Reclamation Inc.</i></p> <p>CONTRACTORS LICENSE NO.: <i>WV007728</i></p> <p>THE SUCCESSFUL BIDDER WILL BE REQUIRED TO FURNISH A COPY OF THEIR CONTRACTORS LICENSE PRIOR TO ISSUANCE OF A PURCHASE ORDER/CONTRACT.</p> <p>APPLICABLE LAW</p> <p>THE WEST VIRGINIA STATE CODE, PURCHASING DIVISION RULES AND REGULATIONS, AND THE INFORMATION PROVIDED IN THE "REQUEST FOR QUOTATION" ISSUED BY THE PURCHASING DIVISION IS THE SOLE AUTHORITY GOVERNING THIS PROCUREMENT.</p> <p>ANY INFORMATION PROVIDED IN SPECIFICATION MANUALS, OR ANY OTHER SOURCE, VERBAL OR WRITTEN, WHICH CONTRADICTS OR ALTERS THE INFORMATION PROVIDED FROM THE SOURCES AS DESCRIBED IN THE ABOVE PARAGRAPH IS VOID AND OF NO EFFECT.</p> <p>BANKRUPTCY: IN THE EVENT THE VENDOR/CONTRACTOR FILES FOR BANKRUPTCY PROTECTION, THE STATE MAY DEEM THIS CONTRACT NULL AND VOID AND TERMINATE SUCH CONTRACT WITHOUT FURTHER ORDER.</p>						

SEE REVERSE SIDE FOR TERMS AND CONDITIONS

SIGNATURE <i>RC</i>	TELEPHONE	DATE 7-29-10
------------------------	-----------	-----------------

TITLE	FEIN	ADDRESS CHANGES TO BE NOTED ABOVE
-------	------	-----------------------------------

WHEN RESPONDING TO RFQ, INSERT NAME AND ADDRESS IN SPACE ABOVE LABELED 'VENDOR'



State of West Virginia
 Department of Administration
 Purchasing Division
 2019 Washington Street East
 Post Office Box 50130
 Charleston, WV 25305-0130

Request for Quotation

RFQ NUMBER
 DEP14397

PAGE
 6

ADDRESS CORRESPONDENCE TO ATTENTION OF:
 CHUCK BOWMAN
 304-558-2157

VENDOR

*709060417 304-984-1115
 CARPENTER RECLAMATION INC
 PO BOX 13015
 SISSONVILLE WV 25360-0015

SHIP TO

ENVIRONMENTAL PROTECTION
 DEPT. OF
 OFFICE OF SPECIAL RECLAMATION
 601 57TH STREET SE
 CHARLESTON, WV
 25304 304-926-0499

DATE PRINTED	TERMS OF SALE	SHIP VIA	F.O.B.	FREIGHT TERMS
05/24/2010				
BID OPENING DATE: 07/14/2010		BID OPENING TIME 01:30PM		

LINE	QUANTITY	UOP	CAT NO	ITEM NUMBER	UNIT PRICE	AMOUNT
<p>PREFERENCE FOR USE OF DOMESTIC STEEL PRODUCTS</p> <p>1. EXCEPT WHEN AUTHORIZED BY THE DIRECTOR OF THE PURCHASING DIVISION PURSUANT TO SUBSECTION 2 BELOW, NO CONTRACTOR MAY USE OR SUPPLY STEEL PRODUCTS FOR A STATE CONTRACT PROJECT OTHER THAN THOSE STEEL PRODUCTS MADE IN THE UNITED STATES AS USED USED IN THIS CONTRACT.</p> <p>A. "STATE CONTRACT PROJECT" MEANS ANY ERECTION OR CONSTRUCTION OF, OR ANY ADDITION TO, ALTERATION OF OR OTHER IMPROVEMENT TO ANY BUILDING OR STRUCTURE, INCLUDING, BUT NOT LIMITED TO, ROADS OR HIGHWAYS, OR THE INSTALLATION OF ANY HEATING OR COOLING OR VENTILATING PLANTS OR OTHER EQUIPMENT, OR THE SUPPLY OF AND MATERIALS FOR SUCH PROJECTS, PURSUANT TO A CONTRACT WITH THE STATE OF WEST VIRGINIA FOR WHICH BIDS WERE SOLICITED ON OR AFTER JUNE 6, 2001.</p> <p>B. "STEEL PRODUCTS" MEANS PRODUCTS ROLLED, FORMED, SHAPED, DRAWN, EXTRUDED, FORGED, CAST, FABRICATED OR OTHERWISE SIMILARLY PROCESSED, OR PROCESSED BY A COMBINATION OF TWO OR MORE OF SUCH OPERATIONS, FROM STEEL MADE BY THE OPEN HEARTH, BASIC OXYGEN, ELECTRIC FURNACE, BESSEMER OR OTHER STEEL MAKING PROCESS.</p> <p>C. "UNITED STATES" MEANS THE UNITED STATES OF AMERICA AND INCLUDES ALL TERRITORY, CONTINENTA OR INSULAR, SUBJECT TO THE JURISDICTION OF THE UNITED STATES.</p> <p>2. THE DIRECTOR OF THE PURCHASING DIVISION MAY, IN WRITING, AUTHORIZE THE USE OF FOREIGN STEEL PRODUCTS IF:</p>						

SEE REVERSE SIDE FOR TERMS AND CONDITIONS

SIGNATURE	TELEPHONE	DATE
TITLE	FEIN	ADDRESS CHANGES TO BE NOTED ABOVE

WHEN RESPONDING TO RFQ, INSERT NAME AND ADDRESS IN SPACE ABOVE LABELED 'VENDOR'



State of West Virginia
 Department of Administration
 Purchasing Division
 2019 Washington Street East
 Post Office Box 50130
 Charleston, WV 25305-0130

Request for Quotation

RFQ NUMBER
DEP14397

PAGE
7

ADDRESS CORRESPONDENCE TO ATTENTION OF
CHUCK BOWMAN 304-558-2157

VENDOR

*709060417 304-984-1115
 CARPENTER RECLAMATION INC
 PO BOX 13015
 SISSONVILLE WV 25360-0015

SHIP TO

ENVIRONMENTAL PROTECTION
 DEPT. OF
 OFFICE OF SPECIAL RECLAMATION
 601 57TH STREET SE
 CHARLESTON, WV
 25304 304-926-0499

DATE PRINTED	TERMS OF SALE	SHIP VIA	F.O.B.	FREIGHT TERMS
05/24/2010				

BID OPENING DATE: 07/14/2010 BID OPENING TIME 01:30PM

LINE	QUANTITY	UOP	CAT NO	ITEM NUMBER	UNIT PRICE	AMOUNT
<p>A. THE COST FOR EACH CONTRACT ITEM USED DOES NOT EXCEED ONE TENTH OF ONE PERCENT (.1%) OF THE TOTAL CONTRACT COST OR TWO THOUSAND FIVE HUNDRED DOLLARS (2,500.00), WHICHEVER IS GREATER. FOR THE PURPOSES OF THIS SECTION, THE COST IS THE VALUE OF THE STEEL PRODUCT AS DELIVERED TO THE PROJECT OR,</p> <p>B. THE DIRECTOR OF THE PURCHASING DIVISION DETERMINES THAT SPECIFIED STEEL MATERIALS ARE NOT PRODUCED IN THE UNITED STATES IN SUFFICIENT QUANTITY OR OTHERWISE ARE NOT REASONABLY AVAILABLE TO MEET CONTRACT REQUIREMENTS.</p> <p>3. A CONTRACTOR WHO USES STEEL PRODUCTS IN VIOLATION OF THIS SECTION MAY BE SUBJECT TO CIVIL PENALTIES PURSUANT TO WV CODE SECTION 5A-3-56.</p> <p>REV. 10/01/01</p> <p>EXHIBIT 7</p> <p>DOMESTIC ALUMINUM, GLASS & STEEL IN PUBLIC WORKS PROJECTS</p> <p>IN ACCORDANCE WITH WEST VIRGINIA CODE 5-19-1 ET., SEQ., EVERY CONTRACT FOR CONSTRUCTION, RECONSTRUCTION, ALTERATION, REPAIR, IMPROVEMENT OR MAINTENANCE OF PUBLIC WORKS, WHERE THE COST IS MORE THAN \$50,000 AND, IN THE CASE OF STEEL ONLY, WHERE THE COST OF STEEL IS MORE THAN \$50,000 OR WHERE MORE THAN 10,000 POUNDS OF STEEL ARE REQUIRED, THE STATE WILL ACCEPT ONLY ALUMINUM GLASS, OR STEEL PRODUCTS PRODUCED IN THE UNITED STATES. IN ADDITION, ITEMS OF MACHINERY OR EQUIPMENT PURCHASED</p>						

SEE REVERSE SIDE FOR TERMS AND CONDITIONS

SIGNATURE	TELEPHONE	DATE
-----------	-----------	------

TITLE	FEIN	ADDRESS CHANGES TO BE NOTED ABOVE
-------	------	-----------------------------------

WHEN RESPONDING TO RFQ, INSERT NAME AND ADDRESS IN SPACE ABOVE LABELED 'VENDOR'



State of West Virginia
 Department of Administration
 Purchasing Division
 2019 Washington Street East
 Post Office Box 50130
 Charleston, WV 25305-0130

Request for Quotation

RFO NUMBER
 DEP14397

PAGE
 8

ADDRESS CORRESPONDENCE TO ATTENTION OF
 CHUCK BOWMAN
 304-558-2157

VENDOR FOR

*709060417 304-984-1115
 CARPENTER RECLAMATION INC
 PO BOX 13015
 SISSONVILLE WV 25360-0015

SHIP TO

ENVIRONMENTAL PROTECTION
 DEPT. OF
 OFFICE OF SPECIAL RECLAMATION
 601 57TH STREET SE
 CHARLESTON, WV
 25304 304-926-0499

DATE PRINTED	TERMS OF SALE	SHIP VIA	F.O.B.	FREIGHT TERMS
05/24/2010				

BID OPENING DATE: 07/14/2010 BID OPENING TIME 01:30PM

LINE	QUANTITY	UOP	CAT NO	ITEM NUMBER	UNIT PRICE	AMOUNT
<p>FOR USE AT THE SITE OF PUBLIC WORKS SHALL BE MADE OF DOMESTIC ALUMINUM, GLASS OR STEEL, UNLESS THE COST OF THE PRODUCT IS LESS THAN \$50,000 OR LESS THAN 10,000 POUNDS OF STEEL ARE USED IN PUBLIC WORKS PROJECTS.</p> <p>FOREIGN MADE ALUMINUM, GLASS OR STEEL PRODUCTS MAY BE ACCEPTED ONLY IF THE COST OF DOMESTIC PRODUCTS IS FOUND TO BE UNREASONABLE. SUCH COST IS UNREASONABLE IF IT IS 20% OR MORE HIGHER THAN THE BID PRICE FOR FOREIGN MADE PRODUCTS. IF THE DOMESTIC ALUMINUM, GLASS OR STEEL PRODUCTS TO BE SUPPLIED OR PRODUCED IN A "SUBSTANTIAL LABOR SURPLUS AREA", AS DEFINED BY THE UNITED STATES DEPARTMENT OF LABOR, FOREIGN PRODUCTS MAY BE SUPPLIED ONLY IF DOMESTIC PRODUCTS ARE 30% OR MORE HIGHER IN PRICE THAN THE FOREIGN MADE PRODUCTS.</p> <p>IF, PRIOR TO THE AWARD OF A CONTRACT UNDER THE ABOVE PROVISIONS, THE SPENDING OFFICER OF THE SPENDING UNIT DETERMINES THAT THERE EXISTS A BID FOR LIKE FOREIGN ALUMINUM, GLASS OR STEEL THAT IS REASONABLE AND LOWER THAN THE LOWEST BID DOMESTIC PRODUCTS, THE SPENDING OFFICE MAY REQUEST, IN WRITING, A REEVALUATION AND REDUCTION IN THE LOWEST BID FOR SUCH DOMESTIC PRODUCTS. ALL VENDORS MUST INDICATE IN THEIR BID IF THEY ARE SUPPLYING FOREIGN ALUMINUM, GLASS OR STEEL.</p> <p>REV. 3/88</p> <p>EXHIBIT 9</p> <p>NOTICE FOR ISSUANCE & ACKNOWLEDGEMENT OF CONSTRUCTION PROJECT ADDENDA</p> <p>THE ARCHITECT/ENGINEER AND/OR AGENCY SHALL BE REQUIRED TO ABIDE BY THE FOLLOWING SCHEDULE IN ISSUING CONSTRUCTION PROJECT ADDENDA FOR STATE AGENCIES:</p>						

SEE REVERSE SIDE FOR TERMS AND CONDITIONS

SIGNATURE	TELEPHONE	DATE
-----------	-----------	------

TITLE	FEIN	ADDRESS CHANGES TO BE NOTED ABOVE
-------	------	-----------------------------------

WHEN RESPONDING TO RFO, INSERT NAME AND ADDRESS IN SPACE ABOVE LABELLED "VENDOR"



State of West Virginia
 Department of Administration
 Purchasing Division
 2019 Washington Street East
 Post Office Box 50130
 Charleston, WV 25305-0130

Request for Quotation

RFQ NUMBER
 DEP14397

PAGE
 9

ADDRESS CORRESPONDENCE TO ATTENTION OF
 CHUCK BOWMAN
 304-558-2157

VENDOR

*709060417 304-984-1115
 CARPENTER RECLAMATION INC
 PO BOX 13015
 SISSONVILLE WV 25360-0015

SHIP TO

ENVIRONMENTAL PROTECTION
 DEPT. OF
 OFFICE OF SPECIAL RECLAMATION
 601 57TH STREET SE
 CHARLESTON, WV
 25304 304-926-0499

DATE PRINTED	TERMS OF SALE	SHIP VIA	F.O.B	FREIGHT TERMS
05/24/2010				

BID OPENING DATE: 07/14/2010 BID OPENING TIME 01:30PM

LINE	QUANTITY	UOP	CAT NO	ITEM NUMBER	UNIT PRICE	AMOUNT
<p>(1) THE ARCHITECT/ENGINEER SHALL PREPARE THE ADDENDUM AND A LIST OF ALL PARTIES THAT HAVE PROCURED DRAWINGS AND SPECIFICATIONS FOR THE PROJECT. THE ADDENDUM AND LIST SHALL BE FORWARDED TO THE BUYER IN THE STATE PURCHASING DIVISION. THE ARCHITECT/ENGINEER SHALL ALSO SEND A COPY OF THE ADDENDUM TO THE STATE AGENCY FOR WHICH THE CONTRACT IS ISSUED.</p> <p>(2) THE BUYER SHALL SEND THE ADDENDUM TO ALL INTERESTED PARTIES AND, IF NECESSARY, EXTEND THE BID OPENING DATE. ANY ADDENDUM SHOULD BE RECEIVED BY THE BUYER WITHIN FOURTEEN (14) DAYS PRIOR TO THE BID OPENING DATE.</p> <p>(3) ALL ADDENDA SHOULD BE FORMALLY ACKNOWLEDGED BY ALL BIDDERS AND SUBMITTED TO THE STATE PURCHASING DIVISION. THE SAME RULES AND REGULATIONS THAT APPLY TO THE ORIGINAL BIDDING DOCUMENT SHALL ALSO APPLY TO AN ADDENDUM DOCUMENT. THE ONLY EXCEPTION MAY BE FOR AN ADDENDUM THAT IS ISSUED FOR THE SOLE PURPOSE OF CHANGING A BID OPENING TIME AND/OR DATE.</p> <p>REV. 11/96</p> <p>EXHIBIT 10</p> <p>ADDENDUM ACKNOWLEDGEMENT</p> <p>I HEREBY ACKNOWLEDGE RECEIPT OF THE FOLLOWING CHECKED ADDENDUM(S) AND HAVE MADE THE NECESSARY REVISIONS TO MY PROPOSAL, PLANS AND/OR SPECIFICATION, ETC.</p> <p>ADDENDUM NOS.:</p>						

SEE REVERSE SIDE FOR TERMS AND CONDITIONS

SIGNATURE *Kelley Carpenter* TELEPHONE DATE 7-29-10

TITLE FEIN ADDRESS CHANGES TO BE NOTED ABOVE

WHEN RESPONDING TO REQ INSERT NAME AND ADDRESS IN SPACE ABOVE LABELLED 'VENDOR'



State of West Virginia
 Department of Administration
 Purchasing Division
 2019 Washington Street East
 Post Office Box 50130
 Charleston, WV 25305-0130

Request for Quotation

RFQ NUMBER
 DEP14397

PAGE
 10

ADDRESS CORRESPONDENCE TO ATTENTION OF
 CHUCK BOWMAN
 804-558-2157

VENDOR

*709060417 304-984-1115
 CARPENTER RECLAMATION INC
 PO BOX 13015
 SISSONVILLE WV 25360-0015

SHIP TO

ENVIRONMENTAL PROTECTION
 DEPT. OF
 OFFICE OF SPECIAL RECLAMATION
 601 57TH STREET SE
 CHARLESTON, WV
 25304 304-926-0499

DATE PRINTED	TERMS OF SALE	SHIP VIA	F.O.B	FREIGHT TERMS
05/24/2010				

BID OPENING DATE: 07/14/2010 BID OPENING TIME 01:30PM

LINE	QUANTITY	UOP	CAT NO	ITEM NUMBER	UNIT PRICE	AMOUNT
NO. 1	.	✓				
NO. 2	.	✓				
NO. 3	.					
NO. 4	.					
NO. 5	.					

I UNDERSTAND THAT FAILURE TO CONFIRM THE RECEIPT OF THE ADDENDUM(S) MAY BE CAUSE FOR REJECTION OF THE BIDS.

VENDOR MUST CLEARLY UNDERSTAND THAT ANY VERBAL REPRESENTATION MADE OR ASSUMED TO BE MADE DURING ANY ORAL DISCUSSION HELD BETWEEN VENDOR'S REPRESENTATIVES AND ANY STATE PERSONNEL IS NOT BINDING. ONLY THE INFORMATION ISSUED IN WRITING AND ADDED TO THE SPECIFICATIONS BY AN OFFICIAL ADDENDUM IS BINDING.

... *Kelley Carpenter* ... SIGNATURE
 ... *Carpenter Reclamation Inc* ... COMPANY
 ... 7-29-10 ... DATE

REV. 11/96

NOTICE

A SIGNED BID MUST BE SUBMITTED TO:
 DEPARTMENT OF ADMINISTRATION
 PURCHASING DIVISION

SEE REVERSE SIDE FOR TERMS AND CONDITIONS

SIGNATURE <i>Kelley Carpenter</i>	TELEPHONE 304 984 1115	DATE 7-29-10
TITLE <i>President</i>	FEIN 55-0693493	ADDRESS CHANGES TO BE NOTED ABOVE

WHEN RESPONDING TO REQ INSERT NAME AND ADDRESS IN SPACE ABOVE LABELED "VENDOR"



State of West Virginia
 Department of Administration
 Purchasing Division
 2019 Washington Street East
 Post Office Box 50130
 Charleston, WV 25305-0130

Request for Quotation

RFQ NUMBER
 DEP14397

PAGE
 11

ADDRESS CORRESPONDENCE TO ATTENTION OF
 CHUCK BOWMAN
 304-558-2157

*709060417 304-984-1115
 CARPENTER RECLAMATION INC
 PO BOX 13015
 SISSONVILLE WV 25360-0015

ENVIRONMENTAL PROTECTION
 DEPT. OF
 OFFICE OF SPECIAL RECLAMATION
 601 57TH STREET SE
 CHARLESTON, WV
 25304 304-926-0499

DATE PRINTED	TERMS OF SALE	SHIP VIA	F.O.B.	FREIGHT TERMS
05/24/2010				

BID OPENING DATE: 07/14/2010 BID OPENING TIME 01:30PM

LINE	QUANTITY	UOP	CAT NO	ITEM NUMBER	UNIT PRICE	AMOUNT
BUILDING 15 2019 WASHINGTON STREET, EAST CHARLESTON, WV 25305-0130 THE BID SHOULD CONTAIN THIS INFORMATION ON THE FACE OF THE ENVELOPE OR THE BID MAY NOT BE CONSIDERED: SEALED BID BUYER: CB-23 REQ. NO.: DEP14397 BID OPENING DATE: 07/14/2010 BID OPENING TIME: 1:30 P.M. PLEASE PROVIDE A FAX NUMBER IN CASE IT IS NECESSARY TO CONTACT YOU REGARDING YOUR BID: <u>304 984 2770</u> ----- PLEASE PRINT OR TYPE NAME OF PERSON TO CONTACT CONCERNING THIS QUOTE: <u>Randy Carpenter 3049841115 3045431726</u>						

SEE REVERSE SIDE FOR TERMS AND CONDITIONS		
SIGNATURE <i>KC</i>	TELEPHONE	DATE 7-29-10

TITLE FEIN ADDRESS CHANGES TO BE NOTED ABOVE

WV-36a STATE OF WEST VIRGINIA
 REV. 1/29/02 PURCHASING CONTINUATION SHEET
 VENDOR:

BUYER CB-23	PAGE	REQ. OR PO NO DEP 14397
SPENDING UNIT WEST VIRGINIA DEPARTMENT OF ENVIRONMENTAL PROTECTION/OFFICE OF SPECIAL RECLAMATION		

PRINCESS SUSAN COAL CO.

S-6-85

At Cedar Grove, WV, turn onto Kelly's Creek Rd. (County Rt. 81/12). Travel @ 1 mile on County Rt 81/12 and turn left at the Ward cemetary. Follow road past cemetary gates and up hill to mine site. Mine site is at the top of the hill.

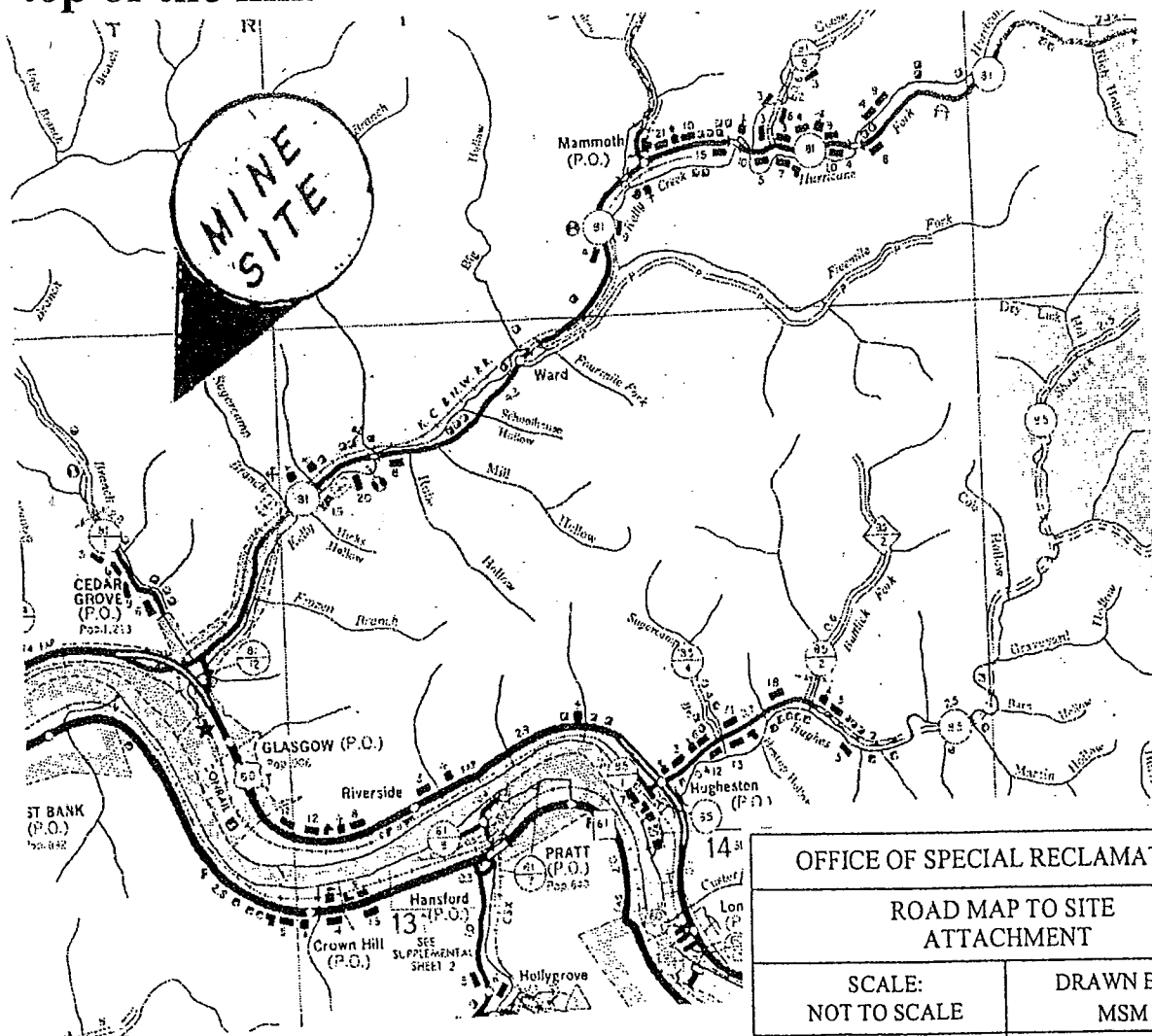

OFFICE OF SPECIAL RECLAMATION	
ROAD MAP TO SITE ATTACHMENT	
SCALE: NOT TO SCALE	DRAWN BY: MSM
DATE: 12/5/2006	PROJECT NO: S-6-85

BUYER CB-23	-	REQ. OR PO NO. DEP 14397
SPENDING UNIT WEST VIRGINIA DEPARTMENT OF ENVIRONMENTAL PROTECTION/SPECIAL RECLAMATION		

WV-36a STATE OF WEST VIRGINIA
REV. 5-26-09 PURCHASING CONTINUATION SHEET
VENDOR:

SCOPE OF WORK

The successful bidder shall provide appropriate equipment, materials, labor and any technical services needed for the successful reclamation of Princess Susan Coal Company, Permit S-6-85, and any disturbance associated with such operation. The General Performance Standards (GPS) shall apply to all items in Scope of Work.

Work necessary on this site will include the following items, but is not limited to these:

1. Upon mobilization to the site, which will be directed in a written Notice to Proceed, the access roads shall be developed in accordance with bid item #3.0. If, fuel and lubricants are to be stored on site, bid item #2.0 shall be in place before fuel is delivered. Project sign is to be obtained and installed.
2. Storm water management in the form as described in bid item #6.0 shall be installed at locations as directed by the DEP on-site representative.
3. Concurrent and continuous reclamation shall begin at point A as shown on the site plan and shall end at point B. Backfill is required for all areas. Regrading and topsoiling is required for all areas. Revegetation and soil improvements are required for all areas. Reclamation is to be according to the attached specifications, plans, and clarifying discussions at the Pre-Bid Conference.
4. Construction stakeout as necessary to carry out work. (Bid Item #4.0)
5. Check for and locate all utilities within the work area to provide and maintain a safe working area in addition to preventing damage to the utility.
6. Construct approximately three hundred linear feet (300LF) limestone rip rap channel number one A (#1A) at the toe of valley fill next to access road. Channel 1A will be lined with eighteen inches (18") of six inch to twelve inch (6"-12") limestone rip-rap choked down with one and a half inch (1 1/2") limestone crusher run. The cost of the stone and excavation will be inclusive in the cost of limestone rip rap channel (1A) (see attached specifications and/or plans).
7. Install two (2) wet mine seals at Site B points shown on site plan. The mine seal sites will be graded to a 2' horizontal to 1' vertical slope using soil capable of supporting vegetation. A grass lined one foot (1') V-ditch will be constructed from the upper mine seal discharge pipe to the lower mine seal discharge pipe. The cost of the stone, pipe, non-woven filter fabric, grass lined V-ditch, and regrading will be inclusive to the cost of the mine seal (see attached specifications and/or plans).
8. Construct approximately four hundred linear feet (400LF) of two foot (2') limestone rip-rap V-ditch number one-B (1B) beginning at mine seal discharge pipe two (2) above hollow and emptying into natural stream channel in hollow below mine seals. Two sections of V-ditch #1B will be grouted rip-rap (approximately 150' total length) with 100% penetration of all voids in r ip-rap as shown on site plans. Non-grouted sections of V-ditch #1B will be constructed using standard limestone rip-rap choked down with one and a half inch (1 1/2") limestone crusher run. Grouted sections will use sandstone or limestone rip-rap and will be "keyed" in at starting and ending points. Cost of the grout, excavation and stone will be inclusive to the cost of V-ditch #1B (see attached specifications and/or plans).
9. Construct approximately sixty linear feet (60LF) of sandstone underdrain at the point designated on the western side of site B. The underdrain will discharge into two foot (2") V-ditch number one B (#1B). Underdrain is to be constructed by excavating a four foot (4') by four foot (4') trench. Placing a layer of non-woven filter fabric in

BUYER CB-23		REQ. OR PO # DEP 14397
SPENDING UNIT WEST VIRGINIA DEPARTMENT OF ENVIRONMENTAL PROTECTION/SPECIAL RECLAMATION		

WV-36a STATE OF WEST VIRGINIA
REV. 5-26-09 PURCHASING CONTINUATION SHEET
VENDOR:

the trench and filling trench with three inches (3") to six inches (6") sandstone rip-rap. The filter fabric will be wrapped 360° around the rip-rap and will have a one foot (1') overlap at any joints in the fabric. Underdrain will be installed as to have a positive discharge in to 2' V-ditch #1B. Cost of the stone and non-woven fabric will be inclusive to the cost of the underdrain (see attached specifications and/or plans).

10. Construct a rock check dam in the hollow immediately to the south of 2' V-ditch 1B as shown on the site C plan. The rock check dam will be constructed of three inch (3") to six inch (6") screened sandstone. Check dam will be keyed in 6" and will have a two foot (2') top width. Check dam will be formed in a v shape with the point of the v facing limestone rip rap channel number two C (#2C). Check dam will be constructed as to direct any water flowing down hollow into limestone channel 2C. The cost of the excavation and stone will be inclusive in the cost of check dam (see attached specifications and/or plans).

11. Construct approximately three hundred linear feet (300LF) of limestone rip rap channel number two C (#2C) at the toe of the rock check dam. Channel 2C will be lined with eighteen inches (18") of six inch to twelve inch (6"-12") limestone rip-rap choked down with one and a half inch (1 1/2") limestone crusher run. The cost of the stone and excavation will be inclusive in the cost of limestone rip rap channel (2C) (see attached specifications and/or plans).

12. Construct approximately three hundred fifty linear feet (350LF) of limestone rip rap channel three D (3D) at point shown on SITE D plan. A limestone rip-rap spillway with drive-thru will be constructed to receive water from existing wetland at the road berm and will discharge into limestone rip rap channel 3D. Channel 3D will be lined with eighteen inches (18") of six inch to twelve inch (6"-12") limestone rip-rap choked down with one and a half inch (1 1/2") limestone crusher run and will discharge into the natural stream channel below Channel 2C. The cost of the excavation, stone, and drive-thru will be inclusive to the cost of limestone rip rap channel 3D (see attached specifications and/or plans).

13. Construct approximately fourteen hundred linear feet (1400LF) of limestone rip-rap channel four E (4E). Channel 4E will start at the area designated as the access road fill and will discharge water into the natural stream channel in the hollow below site E as shown on SITE E plan. A thirty linear foot (30LF) long section will be constructed to receive water from the reworked rock core. A limestone check dam will be constructed in channel 4E just to the south of the first discharge point. A drive-thru will be installed at each point where channel 4E intersects the existing access road. The cost of the excavation, drive-thrus, stone and check dam will be inclusive to the cost of channel 4E (see attached specifications and/or plans).

14. Rework the existing rock core at the eastern side of SITE E by removing and burying sandstone boulders and replacing the boulders with thirty six inch (36") limestone rip-rap. The section of reworked rock core will be approximately fifty feet (50') in length as measured on the surface. The cost of the excavation and stone will be inclusive to the cost of reworking the rock core (see attached specifications and/or plans).

15. Construct a limestone fill/underdrain at point designated as SITE F on site plan. Construct approximately one hundred linear feet (100LF) of two foot by two foot (2' x 2') limestone underdrain from the inside of the access road curve to the discharge point at the out slope of the bench. The underdrain will be constructed of three inch to six inch (3"-6") limestone rip-rap which will be wrapped 360° with non-woven filter fabric. The limestone fill section will be created by filling from the inside of the curve in the existing access road to the tree line with an eighteen inch (18") layer of three inch to six inch (3"-6") limestone rip-rap. The area will be graded prior to the placement of the rip-rap, to drain to the start of the two foot by two foot (2'x 2') limestone underdrain and channel 5F. The cost of the excavation, non-woven filter fabric, grading and stone will be inclusive to the cost of limestone fill/underdrain (see attached specifications and/or plans).

BUYER CB-23	REQ. OR PO NO. DEP 14397
SPENDING UNIT WEST VIRGINIA DEPARTMENT OF ENVIRONMENTAL PROTECTION/SPECIAL RECLAMATION	

WV-36a STATE OF WEST VIRGINIA
REV. 5-26-09 PURCHASING CONTINUATION SHEET
VENDOR:

16. Construct approximately one hundred linear feet (100LF) of limestone channel five F (5F) directly on top of two foot by two foot (2' x 2') limestone underdrain. Channel 5F will receive surface water from the limestone fill area and will discharge water at the out slope of the bench as shown in SITE F plans. Channel 5F will be lined with eighteen inches (18") of three inch to six inch (3"-6") limestone rip-rap. Channel 5F will have a drive-thru installed at the point where the existing access road intersects with channel 5F. The cost of the stone, excavation, and drive-thru will be inclusive to the cost of channel 5F (see attached specifications and/or plans).

17. Construct approximately three hundred twenty five linear feet (325LF) of channel six G (6G). Three hundred linear feet (300LF) of channel 6G will be constructed on top of the existing rock core as shown in SITE G site plan and will discharge into the existing sump. Channel 6G will be lined with eighteen inches (18") of six inch to twelve inch (6"-12") limestone rip-rap choked down with one and a half inch (1 1/2") limestone crusher run. The original ground on each side of channel 6G will be graded to allow surface water to enter the channel. An additional twenty five linear foot (25LF) section of channel 6G will be constructed with eighteen inches (18") of six inch to 12 inch (6" - 12") limestone rip-rap beginning at the drive-thru and will discharge into existing streambed. The cost of the excavation and stone will be inclusive to the cost of channel 6G (see attached specifications and/or plans).

18. Rework the existing sump at the end of the rock core / channel 6G by excavating out any accumulated sediment and vegetation to a depth of eighteen inches (18") below the grade of the existing culvert pipe. The sump embankment will also be removed down to the existing culvert. A new sump embankment will be constructed using standard limestone rip-rap with a drive-thru installed on top of the embankment. The drive-thru will be constructed of six inches (6") of three inch to 6 inch (3" - 6") limestone rip-rap choked down with three inch (3") limestone crusher run on top of the standard limestone rip-rap embankment. The sump will be lined with eighteen inches (18") of six inch (6") limestone rip-rap. Sump will discharge through existing road culvert as well as limestone underdrain. The cost of the excavation, drive thru, underdrain, and stone will be inclusive to the cost of reworking the existing sump at Site G (see attached specifications and/or plans).

19. Construct a four foot by four foot (4' x 4') sandstone underdrain as shown on SITE H site plan. Underdrain will be constructed of six inch (6") limestone rip-rap and will be wrapped with non-woven filter fabric, 360° around the sandstone rip-rap with a one foot (1') overlap of the filter fabric. Underdrain shall be covered with a minimum of six inches (6") of soil except where the underdrain intersects the access road which will be covered with road surfacing material. The underdrain will discharge any collected water into a limestone fill. The cost of the stone, excavation, and non-woven filter fabric will be inclusive to the cost of the underdrain (see attached specifications and/or plans).

20. Construct a limestone fill area at the point designated on the SITE H site plan. The limestone fill will receive water from the four foot by four foot (4' x 4') sandstone underdrain as well as surface runoff. The center of the limestone fill shall be swaled to allow high surface water flows to discharge over the bench out slope. The fill will be constructed by excavating a triangle shaped area to a depth of four feet (4') (see typical attachment). The bottom six inches (6") will be filled with three inch (3") limestone crusher run. The remaining three and one half foot (3 1/2') will be filled with standard limestone rip-rap. The cost of the excavation and stone will be inclusive to the cost of the Site H limestone fill (see attached specifications and/or plans).

21. Construct six (6) additional limestone fills at the points designated on site plan and at the direction of the on-site DEP personnel. The center of the limestone fill shall be swaled to allow high surface water flows to discharge

BUYER CB-23	REQ. OR PO NO. DEP 14397
SPENDING UNIT WEST VIRGINIA DEPARTMENT OF ENVIRONMENTAL PROTECTION/SPECIAL RECLAMATION	

WV-36a STATE OF WEST VIRGINIA
REV. 5-26-09 PURCHASING CONTINUATION SHEET
VENDOR:

over the bench out slope. The fills will be constructed by excavating a triangle shaped area to a depth of three feet (3') (see typical attachment). The bottom six inches (6") will be filled with three inch (3") limestone crusher run. The remaining two and one half feet (2 1/2') will be filled with standard limestone rip-rap. The cost of the excavation and stone will be inclusive to the cost of the limestone fill (see attached specifications and/or plans).

22. Construct approximately two hundred fifty linear feet (250LF) of limestone channel number seven (#7) at the point designated on the site plan. Channel will be constructed by excavating to the width and depth shown on the typical. The channel will be lined with a six inch (6") layer of three inch (3") limestone crusher run with twelve inches (12") of standard limestone rip-rap. Channel number seven (#7) will receive surface water from the existing hollow and will discharge water into the existing road ditch. A drive-thru will be installed at the intersection with the access road. The cost of the stone, drive-thru, and excavation will be inclusive to the cost of channel number seven (#7) (see attached specifications and/or plans).

23. Construct approximately four hundred fifty feet (450') of Site A access road. The access road will begin at the existing access road and will end at limestone channel 1A. A layer of woven filter fabric will be placed on the constructed roadbed prior to placing six inches (6") of three inch (3") limestone crusher run. The crusher run shall be compacted by three (3) passes with a D-6 or larger dozer. The cost of the excavation, woven filter fabric, and stone shall be inclusive to the cost of the site A access road (see attached specifications and/or plans).

24. Construct approximately six hundred feet (600') of site C access road. The access road will begin at the existing access road and will end at end of channel 2C. A layer of woven filter fabric will be placed on the constructed road bed prior to placing six inches (6") of three inch (3") limestone crusher run. The crusher run shall be compacted by three (3) passes with a D-6 or larger dozer. The cost of the excavation, woven filter fabric, and stone shall be inclusive to the cost of site C access road (see attached specifications and/or plans).

25. Construct approximately five hundred feet (500') of site E access road. The access road will begin at the existing access road and will end at end of Channel 4E. A layer of woven filter fabric will be placed on the constructed road bed prior to placing six inches (6") of three inch (3") limestone crusher run. The crusher run shall be compacted by three (3) passes with a D-6 or larger dozer. The cost of the excavation, woven filter fabric, and stone shall be inclusive to the cost of site E access road (see attached specifications and/or plans).

26. Rework approximately ten thousand six hundred feet (10,600') of existing access road to a minimum ten foot (10') width around the entire bench. Existing access road will be regraded to provide positive drainage. A layer of woven filter fabric will be placed on the roadbed followed by a six inch (6") layer of three inch (3") limestone crusher run. The crusher run shall be compacted by three (3) passes with a D-6 or larger dozer. The cost of the excavation, woven filter fabric, and stone shall be inclusive to the cost of reworking the access road (see attached specifications and/or plans).

27. Regrade and revegetate all site disturbances using standard seed and fertilizer mixture with agricultural lime applied at a rate of three (3) tons per acre (see attached specifications and/or plans).

28. Existing access roads will be graded and maintained through the life of the contract to provide all weather access to permit area.

29. Remove all junk and debris from site and dispose of properly. Receipt or record showing proper disposal required with invoice.

BUYER CB-23	REQ. OR PO NO. DEP 14397
SPENDING UNIT WEST VIRGINIA DEPARTMENT OF ENVIRONMENTAL PROTECTION/SPECIAL RECLAMATION	

WV-36a STATE OF WEST VIRGINIA
REV. 5-26-09 PURCHASING CONTINUATION SHEET
VENDOR:

30. Install approximately one thousand linear feet (1,000LF) of sediment control as shown on the site map and as directed by on-site DEP personnel.

I, Stephen R, Nestor, the undersigned, hereby certify¹ that this Reclamation Plan is correct and shows to the best of my knowledge and belief all the information required by the surface mining laws of the State of West Virginia. The source of information was the approved mining and reclamation plan contained in the forfeited surface mine permit, existing site conditions and information contained in the WV DEP, Inspection and Enforcement files.

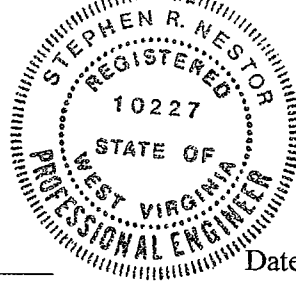

Stephen R. Nestor

Date:

March 8, 2010

Registered Professional Engineer WV No. 10227

¹ The term "**certify**" as used herein is defined as follows: An engineer's certification of conditions is a declaration of professional judgment. It does not constitute a warranty or guarantee, either expressed or implied.

BUYER CB-23	REQ. OR PO NO. DEP 14397
SPENDING UNIT WEST VIRGINIA DEPARTMENT OF ENVIRONMENTAL PROTECTION/SPECIAL RECLAMATION	

WV-36a STATE OF WEST VIRGINIA
 REV. 5-26-09 PURCHASING CONTINUATION SHEET
 VENDOR: *Carpenter Reclamation, Inc.*

ITEM NO.	QUANTITY	DESCRIPTION	UNIT PRICE	AMOUNT
BID SCHEDULE				
PERMIT NAME: <u>Princess Susan Coal Company</u> PERMIT NUMBER(S): <u>S-6-85</u>				
The DEP reserves the right to request additional information and supporting documentation regarding unit prices when the unit price appears to be unreasonable.				
<u>WATER QUALITY ABATEMENT</u>				
1.0	LUMP SUM	<u>MOBILIZATION/DEMobilIZATION/PROJECT SIGN</u> (5% Total Bid Maximum for this permit)	LUMP SUM	\$ <u>25,000.00</u>
2.0	LUMP SUM	<u>SPILL CONTAINMENT AREA (S.C.A.)</u> (\$1,000.00 Maximum Bid for this permit)	LUMP SUM	\$ <u>1.00</u>
3.0	10,600 LF	<u>HAULROAD/ACCESS ROAD UPGRADE</u>	\$ <u>17.00</u> PER LF	\$ <u>180,200.00</u>
4.0	LUMP SUM	<u>CONSTRUCTION STAKEOUT</u> (Limited to 5% total bid for this permit)	LUMP SUM	\$ <u>25,000.00</u>
<u>REVEGETATION</u>				
5.1	25 ACRES	<u>AGRICULTURAL LIME</u>	\$ <u>600.00</u> PER ACRE	\$ <u>15,000.00</u>
5.2	25 ACRES	<u>FERTILIZER</u>	\$ <u>600.00</u> PER ACRE	\$ <u>15,000.00</u>
5.3	25 ACRES	<u>MULCH</u>	\$ <u>600.00</u> PER ACRE	\$ <u>15,000.00</u>
5.4	25 ACRES	<u>VEGETATIVE SPECIES</u>	\$ <u>600.00</u> PER ACRE	\$ <u>15,000.00</u>
6.0	1000 LF	<u>SEDIMENT CONTROL</u>	\$ <u>4.00</u> per LF	\$ <u>4,000.00</u>
<u>GROUTED RIP-RAP DITCH</u>				
7.1	150 LF	<u>V-DITCH ONE B (1B)</u>	\$ <u>85.00</u> per LF	\$ <u>12,750.00</u>
<u>OPEN LIMESTONE CHANNEL</u>				
8.0				

BUYER CB-23	REQ. OR PO NO. DEP 14397
SPENDING UNIT WEST VIRGINIA DEPARTMENT OF ENVIRONMENTAL PROTECTION/SPECIAL RECLAMATION	

WV-36a STATE OF WEST VIRGINIA
REV. 5-26-09 PURCHASING CONTINUATION SHEET
VENDOR: *Carpenter Reclamation Inc.*

ITEM NO.	QUANTITY	DESCRIPTION	UNIT PRICE	AMOUNT
8.1	300 LF	<u>CHANNEL ONE A (1A)</u>	\$ 80.00	\$ 24,000.00
8.2	250 LF	<u>V-DITCH ONE B (1B)</u>	per LF \$ 80.00	\$ 20,000.00
8.3	300 LF	<u>CHANNEL TWO C (2C)</u>	per LF \$ 80.00	\$ 24,000.00
8.4	350 LF	<u>CHANNEL THREE D (3D)</u>	per LF \$ 80.00	\$ 28,000.00
8.5	1400 LF	<u>CHANNEL FOUR E (4E)</u>	per LF \$ 80.00	\$ 112,000.00
8.6	100 LF	<u>CHANNEL FIVE F (5F)</u>	per LF \$ 80.00	\$ 8,000.00
8.7	325 LF	<u>CHANNEL SIX G (6G)</u>	per LF \$ 60.00	\$ 19,500.00
8.8	250 LF	<u>CHANNEL SEVEN (7)</u>	per LF \$ 80.00	\$ 20,000.00
9.0	50 LF	<u>ROCK CORE</u>	per LF \$ 60.00	\$ 3,000.00
10.0	60 LF	<u>SITE B SANDSTONE UNDERDRAIN</u>	per LF \$ 40.00	\$ 2,400.00
11.0	LUMP SUM	<u>STRUCTURE AND/OR DEBRIS REMOVAL</u>	LUMP SUM	\$ 10,000.00
12.0	NO BID ITEM	<u>UTILITIES</u>	NO BID ITEM	
13.0	6 EACH	<u>LIMESTONE FILLS</u>	\$ 4,000.00 PER EACH	\$ 24,000.00
14.0	2 EACH	<u>INSTALL WET MINE SEALS</u>	\$ 6,000.00 PER EACH	\$ 12,000.00
15.0	LUMP SUM	<u>ROCK CHECK DAM</u>	LUMP SUM	\$ 1,000.00
16.0	LUMP SUM	<u>SITE F LIMESTONE FILL/UNDERDRAIN</u>	LUMP SUM	\$ 4,000.00
17.0	LUMP SUM	<u>SITE H LIMESTONE FILL</u>	LUMP SUM	\$ 4,000.00
18.0	300 LF	<u>SITE H SANDSTONE UNDERDRAIN</u>	\$ 40.00 PER LF	\$ 12,000.00
19.0	LUMP SUM	<u>REWORK EXISTING SUMP AT SITE G</u>	LUMP SUM	\$ 3,000.00
20.0		<u>CONSTRUCTED ACCESS ROAD</u>		
20.1	450 LF	<u>SITE A ACCESS ROAD</u>	\$ 15.00 PER LF	\$ 6,750.00

BUYER CB-23	REQ. OR PO NO. DEP 14397
SPENDING UNIT WEST VIRGINIA DEPARTMENT OF ENVIRONMENTAL PROTECTION/SPECIAL RECLAMATION	

WV-36a STATE OF WEST VIRGINIA
 REV. 5-26-09 PURCHASING CONTINUATION SHEET
 VENDOR: *Carpenter Reclamation Ins.*

ITEM NO.	QUANTITY	DESCRIPTION	UNIT PRICE	AMOUNT
20.2	600 LF	<u>SITE C ACCESS ROAD</u>	\$ 15.00 PER LF	\$ 9,000.00
20.3	500 LF	<u>SITE E ACCESS ROAD</u>	\$ 15.00 PER LF	\$ 7,500.00
TOTAL PERMIT				\$ 166,101.00

BUYER CB-23	REQ. OR PO NO. DEP 14397
SPENDING UNIT WEST VIRGINIA DEPARTMENT OF ENVIRONMENTAL PROTECTION/SPECIAL RECLAMATION	

WV-36a STATE OF WEST VIRGINIA
REV. 5-26-09 PURCHASING CONTINUATION SHEET
VENDOR:

BID ITEM TECHNICAL SPECIFICATIONS

1.0 MOBILIZATION/DEMOBILIZATION/PROJECT SIGN

A project sign shall be obtained or manufactured and installed as indicated on the attached specifications and details. Payment for this sign shall be incidental to the mobilization item. No separate payment will be made.

MOBILIZATION

This work shall consist of the performance of construction preparatory operations, including the movement of personnel, equipment and other facilities to the project site necessary to begin work on a substantial phase of the contract.

DEMOBILIZATION

Prior to demobilization, an inspection shall be conducted by the Department of Environmental Protection and the contractor to insure compliance with contract performance. Once compliance is ascertained, demobilization activities can be initiated and completed. Demobilization shall be totally completed before the invoice for payment shall be processed.

PAYMENT

The lump sum bid for this item shall not exceed 5% of the total bid for this permit. Payment shall be made in two 50% amounts, one upon completion of the mobilization and project sign items and the second payment at the completion of demobilization. No deduction shall be made nor shall any increase be made in the lump sum item amount, regardless of decreases or increases in the final total contract amount or any other reason.

2.0 SPILL CONTAINMENT AREA (S.C.A.)

Spill containment measures shall be used for fuel and lubricant storage areas. All containers, barrels, buckets, cans, etc., are to be legally disposed of off site. Used lubricants are to be disposed of according to state law to minimize pollution to the local surface and ground water supplies. Spills are the responsibility of the contractor and need immediate clean up and maintained at no expense to the State. This S.C.A. shall be constructed in accordance with the typical drawing specification. (See Attachment) Alternate containment measures will be considered for approval by the Program Manager if acceptable results can be shown. Fuel tanks manufactured with secondary containment are desirable. Minimum secondary containment is 110 percent. (Bid limited to \$1,000.00 maximum)

3.0, 20.1, 20.2, 20.3 HAULROAD/ACCESS ROAD UPGRADE

The contractor shall maintain and/or construct haulroad/access road(s) during the reclamation process to provide access on a well drained surface. Plan to upgrade the existing access road to the specifications and details as indicated in the Upgrade Access Road drawing. The access road on the reclamation site shall be graded, sloped, and maintained to drain to provide a road surface free of excessive mud and standing waters at all times while work is in progress. Upon completion of all reclamation activities, a final 3 inch layer of 1 ½ crusher run limestone shall be placed on the roadway. Roads which are below the project shall be guarded against rolling rock and removal of rocks done as necessary. Dust-control measures may be necessary if hauling creates airborne material. Snow removal is to be included in this item.

4.0 CONSTRUCTION STAKEOUT

This work shall consist of furnishing, placing, and maintaining construction layout stakes necessary for the proper execution of the work required under the Contract, production of as-built drawings, and of performing

BUYER CB-23	REQ. OR PO NO. DEP 14397
SPENDING UNIT WEST VIRGINIA DEPARTMENT OF ENVIRONMENTAL PROTECTION: SPECIAL RECLAMATION	

WV-36a STATE OF WEST VIRGINIA
 REV. 5-26-09 PURCHASING CONTINUATION SHEET
 VENDOR:

topographic surveys and obtaining surveyed cross-sections for accurate determination of pay item quantities. Construction stakeout shall be under the supervision of a Registered Professional Engineer or Licensed Land Surveyor and all drawings signed and/or sealed by such. (Shall not exceed 5% of the total bid for this permit.)

A. MATERIALS

Wooden stakes and other marking materials as described herein.

B. CONSTRUCTION METHODS

B(1). The Contractor shall locate and reference the construction baseline within the limits of work and shall establish bench marks for the proper layout of the work. The Contractor shall make all calculations involved and shall furnish and place all layout stakes or markers.

B(2). The Contractor shall provide field forces and shall set all additional stakes needed, such as offset stakes, reference point stakes, slope stakes, pavement and grade stakes, stakes for roadway drainage, sub-drains, trench drains, fence, culverts or other structures, supplementary bench marks and any other horizontal or vertical controls necessary to secure a correct layout of the work.

B(3). The location of the slope stakes for grading work shall be determined by a calculation method. Elevation control hubs with guard stakes shall be set, at a convenient distance outside the construction limits, and at all stations where original cross-sections are taken. The centerline station, the distance from centerline, and the elevation of the hub shall be recorded on each guard stake.

B(4). The Contractor shall be responsible for having the layout staking work conform to the lines, grades, elevations, and dimensions called for on the Plans. The Contractor shall be responsible for reporting any discrepancies to the Supervisor for clarification. Minor adjustments to suit field conditions are anticipated and it shall be the responsibility of the Supervisor to make decisions regarding adjustments.

B(5). The Contractor shall survey cross-sections and/or profiles in areas of on-site excavation, off-site excavation, and ditch construction as necessary to permit accurate determination of pay item quantities. The locations and spacing of cross-sections and profiles shall be as approved or as directed by the Supervisor. Cross-sections and profiles shall be surveyed:

- a) prior to any excavation
- b) at the completion of excavation

B(6). The Contractor shall furnish a copy of his survey records for the Supervisor and for the DEP's permanent file. These records shall be furnished as they are completed during the progress of the work. Any inspection or checking of the Contractor's layout by the Supervisor and the acceptance of all or any part of it shall not relieve the Contractor of his responsibility to secure the proper dimensions, grades and elevations of the required work.

5.0 REVEGETATION

The actual seeding date, within the work performance period, shall be at the discretion of the contractor, but a permanent vegetative cover must be established. Verification of materials used shall be required for payment. Seed bed preparation, unless otherwise approved, shall be conducted by industrial disks or tracking with heavy equipment with cleat marks across slope and parallel to the final contours. The surface shall be tracked, track to track. Seeding

BUYER CB-23		REQ. OR PO NO. DEP 14397
SPENDING UNIT WEST VIRGINIA DEPARTMENT OF ENVIRONMENTAL PROTECTION/SPECIAL RECLAMATION		

WV-36a STATE OF WEST VIRGINIA
REV. 5-26-09 PURCHASING CONTINUATION SHEET
VENDOR:

shall commence after seedbed preparation on a loose and uncompacted soil and with the approval of the Department of Environmental Protection. Contractor shall provide equipment as necessary to secure approval of the seedbed. Revegetation activities shall be carried out in a continuous, concurrent, timely and uniform manner. Failure to do this may result in nonpayment for portions of or the entire Revegetation item. Hydroseeding or broadcast seeding with the approved species is acceptable. The application rate may be increased but the ratio is to remain constant, but no additional monetary compensation will be awarded. Areas outside the limits of construction, disturbed by the contractor, shall be revegetated by the contractor at no expense to DEP. Water utilized for hydroseeding shall be free of injurious or other toxic substances harmful to plant life. The source of water is subject to the approval of the DEP Specialist. It shall be the vendor's responsibility to repeat the procedures under REVEGETATION until a permanent vegetation is established. The acreage quantities in this contract are for bidding purposes only.

A warranty period of one (1) year shall commence upon completion and payment of the revegetation item of the contract. No payment will be made for additional seeding necessary to comply with warranty requirements. The warranty period will be extended for one (1) year from the date of the last augmented seeding done by the contractor. The performance bond and labor and materials bond shall remain in effect throughout the warranty period. The Standards for Evaluating Vegetative Cover as presented in Title 38, CSR2, Section 9 of the West Virginia Surface Mining Reclamation Regulations will apply.

Equipment for the retracking/scarification to eliminate rills and gullies shall be mobilized and utilized to produce slopes consistent with the regrading and topsoiling bid item prior to warranty reseeding. No additional payment will be made by DEP for this warranty work.

5.1 AGRICULTURAL LIME

Unless otherwise specified, all lime used shall be registered with the West Virginia Department of Agriculture, have an 85% minimum calcium carbonate equivalent, and meet the fineness classification no larger than that for ground lime. The following fineness classifications or combinations of lime are acceptable:

- Pulverized - 100% passing a U.S. Standard 20 mesh sieve
- 70% passing a U.S. Standard 100 mesh sieve
- Ground - 90% passing a U.S. Standard 20 mesh sieve
- 50% passing a U.S. Standard 60 mesh sieve
- 35% passing a U.S. Standard 100 mesh sieve

Use of blends and low-grade agricultural liming materials shall require prior approval. Lime shall be spread as soon as possible after delivery to site. Lime shall be applied evenly and uniformly distributed over the treated area. Lime shall be thoroughly mixed into the soil material. Lime subjected to adverse conditions before spreading will be deemed unacceptable. Failure to complete this phase shall result in nonpayment of this bid item.

Lime shall be applied at 3 ton/acre.

5.2 FERTILIZER

Fertilizer rates given for REVEGETATION are for 1,000 lbs. of 10-20-20 per acre. These rates are minimum and for bidding purposes.

Fertilizer shall be applied evenly and uniformly distributed over the treated area. Common complete fertilizers which meet the minimum standards are acceptable.

5.3 MULCH

Acceptable mulch for this project is wood fiber, hay, or straw.

Mulch: Wood Fiber @ 1.0 ton/Acre

Hay or straw mulch may be substituted at a rate of 2 tons/Acre

BUYER CB-23	REQ. OR PO NO. 24 DEP 14397
SPENDING UNIT WEST VIRGINIA DEPARTMENT OF ENVIRONMENTAL PROTECTION/SPECIAL RECLAMATION	

WV-36a STATE OF WEST VIRGINIA
REV. 5-26-09 PURCHASING CONTINUATION SHEET
VENDOR:

5.4 VEGETATIVE SPECIES

Seeding rate required is for pure live seed (pls) in pounds per acre. The use of annuals or cover crops will not be considered for vegetative success.

SOUTH MIX	
VEGETATIVE SPECIES ¹	RATE/ACRE ¹
Orchard Grass	@ 30 lbs/acre
Birdsfoot Trefoil ²	@ 15 lbs/acre
Red Top	@ 10 lbs/acre
KY 31 Fescue	@ 10 lbs/acre
Perennial Ryegrass	@ 10 lbs/acre
Alsike Clover ²	@ 5 lbs/acre
Black Locust ³	@ 1 lbs/acre
Bicolor Lespedeza ⁴	@ ¼ lbs/acre

1. Seeding rate required is for pure live seed in pounds (lbs) per acre.
2. Herbaceous legumes must be treated with the appropriate bacterium before seeding.
3. This species to be utilized only for woodland post-mining land-use projects.
4. This species to be utilized only for wildlife post-mining land projects.

6.0 SEDIMENT CONTROL WITH SILT FENCE AND HAYBALE DIKE

Disturbed areas which have storm water runoff and does not pass through a sediment control structure shall utilize the following Best Management Practice (BMP) methods to manage storm water runoff. For more information on BMP methods go to the WVDEP website <http://www.wvdep.org/dwwm/stormwater/BMP.htm> and click on **BMP Manual**. The WV Erosion and Sediment Control Best Management Practice Manual may be accessed or printed. This item has a Maximum Bid of \$5.00/LF of silt fence and hay bale material used on site.

1. Silt fence shall be utilized on perimeter barriers and shall be properly removed after permanent vegetation has been established. See attached drawing for further details.
2. For slope stability, place bales on the contour; at the top of cuts; and at the toe of slopes. Bales shall be placed in a row with ends tightly abutting the adjacent bales.
3. Bales shall be securely anchored in place by stakes or rebars driven through the bales. Rebar to be removed at the direction of DEP. The first stake in each bale shall be driven toward previously laid bale to force the bales together.
4. Construction of sediment control sumps before culvert inlets and/or rock check dams in ditch lines may become necessary to supplement the silt fence and hay bale dikes. These items shall be installed upon request of the DEP onsite representative. Sumps and rock check dams shall be incidental to this bid item.

7.1 GROUTED RIPRAP DITCH

Unless otherwise noted shall be durable rock placed in a 1.5 foot thick blanket. Twenty-five percent (25%) of the rock will be 18 inches or larger. Ten percent (10%) of the rock shall be no smaller than six (6) inches. The remaining sixty-five percent (65%) of the rock shall be well graded between six (6) and eighteen (18) inches. In-

BUYER CB-23	REQ. OR PO NO. DEP 14397
SPENDING UNIT WEST VIRGINIA DEPARTMENT OF ENVIRONMENTAL PROTECTION/SPECIAL RECLAMATION	

WV-36a STATE OF WEST VIRGINIA
REV. 5-26-09 PURCHASING CONTINUATION SHEET
VENDOR: _____

place rammed or hammered rock shall be acceptable.

The grout filler shall be composed of a mixture of one part Type II (sulfate resistant) portland cement and three parts sand, mixed with water to produce a workable consistency. The stone shall be thoroughly wet immediately before grout is applied. As soon as the grout is deposited on the surface, it shall be thoroughly worked into the joints. The stones shall then be brushed, so that their top surfaces are exposed. Grout shall penetrate 100% of the riprap thickness.

8.1, 8.2, 8.3, 8.4, 8.5, 8.6, 8.7, 8.8, 19.0 OPEN LIMESTONE CHANNEL

Provide all materials, excavate and construct Ditch as indicated on the attached typical plans, cross-section, specifications, and as discussed at the Pre-Bid Showing. Limestone riprap to be used. Ditches shall be free draining upon completion of construction. Length of ditch may be adjusted to meet on site conditions. (See riprap specifications)

9.0 ROCK CORE

A minimum of fifty (50) feet of the existing rock core underdrain shall be removed from the beneath the spoil backfill, at the location as noted during the on-site pre-bid meeting. The existing core rock shall be broken up as necessary to facilitate removal and disposal to an on-site location designated by the DEP representative. The area for rock core reconstruction shall then be cleared of all trees, brush, shrubs, and other organic material which is above ground level. This material shall also be disposed of outside the core construction area to a designated location.

The rock core shall consist of durable non-acid producing or toxic forming limestone rock of an average diameter of twenty-four (24) to thirty-six (36) inches. Rock core material shall not contain more than ten percent (10%) fines, and which is free of coal, clay or other non-durable material.

The minimum size of the replacement rock core underdrain shall match the dimensions of the existing rock core, approximately twenty (20) feet wide and a height of ten (10) feet. All adjacent areas shall then be immediately stabilized to prevent loose soil materials from washing or otherwise inadvertently entering and clogging the underdrain.

10.0, 16.0, 18.0 UNDERDRAIN

Collection underdrains shall be constructed to collect all seep water for conveyance to the treatment sites. The type of collection underdrains will include the following:

- (1) Sandstone underdrains shall be 4 ft X 4 ft in cross-sections. Stone for the underdrain shall be non-calcerous with a size of 3" to 6" in diameter.
- (2) Limestone underdrains shall be 2 ft X 2 ft in cross-sections. Stone for the underdrain shall be limestone with a size of 3" to 6" in diameter.

The drain shall be wrapped with filter fabric (Tyvar 3401 or equivalent). Filter fabric may be omitted from areas where the seepage enters the underdrain if approved by the DEP on site representative. A 12" (or 6") perforated SDR-35 PVC pipe shall extend the length of the underdrain and connect to solid pipe. The solid pipe shall daylight to the V-ditch leading into the collection pond. An animal guard shall be installed on the exit of the pipe. The perforated end of the 12" (or 6") pipe seep collector shall extend to the surface as a clean-out and may be reduced to 6" diameter pipe with a cap.

Cover the underdrain with a minimum of 1 ft. of material and grade the surface so it is well drained. Material on the downslope side of the drain shall be impervious to prevent leakage from the underdrain to the

BUYER CB-23	REQ. OR PO NO. DEP 14397
SPENDING UNIT WEST VIRGINIA DEPARTMENT OF ENVIRONMENTAL PROTECTION/SPECIAL RECLAMATION	

WV-36a STATE OF WEST VIRGINIA
 REV. 5-26-09 PURCHASING CONTINUATION SHEET
 VENDOR:

surface. Provide all fittings necessary for installation. Refer to the attached drawing for further details. All materials specified above and on the attached drawing shall be incidental to this bid item. Payment for each underdrain is for complete installation and verified by DEP with photo.

3.0, 10.0, 16.0, 18.0, 20.1, 20.2, 20.3 ENGINEERING FABRIC

General: Engineering fabric shall be of the nonwoven or woven type and consists of a pervious sheet of polymeric fibers oriented into a stable network such that the fibers retain their relative positions with respect to each other. The fabric shall be mildew and rot resistant, and shall be free of any treatment or coating which might detrimentally alter its physical properties. The fabric, including the edges or the ends of the rolls, shall be protected during shipment and storage from ultra violet rays, temperature greater than 140° F and contaminants such as mud, dust, etc.

Engineering Fabric for Subsurface Drainage and Separation:

The engineering fabric for subsurface drainage shall be the nonwoven type and the engineering fabric for separation may be the nonwoven or woven type meeting the following requirements:

PROPERTY	MINIMUM REQUIRED VALUE	TEST METHOD
Permeability	1 x 10 ² cm/sec	AH, 20 cm. to 10 cm.
Equivalent Opening Size ²	#50 U.S. Std. Sieve	COE CW-02215
Grab Tensile Strength ³	100 lbs.	ASTM D-1682
Grad Tensile Elongation ³	30%	ASTM D-1682
Puncture Strength ⁴	35 lbs.	ASTM D-3787
Burst Strength	130 psi	ASTM D-3786
Trapezoid Tear	35 lbs.	ASTM D-1117

1. All numerical values represent minimum average roll values (i.e., any roll in a lot shall meet or exceed the minimum value in the table)
2. No greater opening than a #50 U.S. Sieve.
3. Minimum in weakest principal direction.
4. Tension testing machine with ring clamp, steel ball replaced with 5/16 inch diameter solid steel cylinder with either a flat or hemispherical tip centered within the ring clamp.

11.0 STRUCTURE AND/OR DEBRIS REMOVAL

All existing man-made items particular to the site and not to be utilized in the total reclamation of this site shall be demolished (if necessary) and disposed of in a legal manner. All iron, steel, aluminum, or any other metal, plastic, or any other man made material, including but not limited to I-Beams, Angle Iron, Channel Iron, Corrugated Metal, Flat Metal, Floc Drums, Grease Drums, Pipe or Conduit is to be dismantled, removed and properly disposed of off site and according to state, local, and federal requirements. These structures are identified as:

12.0 UTILITIES

Utilities shall be relocated at the direction of the utility company and reimbursed actual cost to the contractor. This is a "No Bid" item due to the method of reimbursement. It is the contractor's responsibility to determine the exact location of each utility in the project area where these utilities would be interrupted or damaged by performing work.

13.0, 16.0, 17.0 OPEN LIMESTONE FILLS

Provide all materials, excavate and construct fills as indicated on the attached typical plans, cross-sections, specifications, and as discussed at the Pre-Bid Showing. Three inch (3") Limestone crusher run is to be used on the floor of the fills and standard Limestone riprap is to be used for remainder of the fill. Length and width of fills will

BUYER CB-23	REQ. OR PO NO. DEP 14397
SPENDING UNIT WEST VIRGINIA DEPARTMENT OF ENVIRONMENTAL PROTECTION/SPECIAL RECLAMATION	

WV-36a STATE OF WEST VIRGINIA
REV. 5-26-09 PURCHASING CONTINUATION SHEET
VENDOR: _____

be determined by site conditions and DEP representative on site. (See specifications and typicals)

14.0 DEEP MINE SEALS [Wet Type (Acid Producing Seams)]

A seal shall be constructed to conform to the plans and specifications as shown in drawing titled "Typical Wet Seal Drawing". Payment of each seal is for complete installation and verification by DEP performance with photo.

15.0 CHECK DAMS

Provide all materials, clear, grub, and excavate as necessary and construct check dam as indicated on the attached typical plans, cross-section and specifications, and as discussed at the Pre-Bid showing.

Durable limestone riprap shall be placed and shaped as follows:

Maximum height of the dam is three feet (3') above the flow centerline of the stream. The center of the dam shall be at least six inches (6") lower than the sides to allow higher flows to be contained over the center of the structure as opposed to around the edges. Rock shall be keyed into the original ground at least one foot (1') to provide stability. Side slopes shall be no steeper than 1.5 H: 1V. The top width of the dam shall be five feet (5').

Twenty five percent (25%) percent of the rock will be twelve inches (12") or larger. Ten percent (10%) of the rock shall be no smaller than four inches (4"). The remaining sixty five percent (65%) of the rock shall be well graded between four (4) and twelve (12) inches. In place rammed or hammered rock shall be acceptable.

The dam shall be inspected a minimum of once per week and within 24 hours of any storm event greater than 0.5 inches. Stone shall be replaced and dam repaired as necessary to maintain the above geometry and overflow capability. Sediment shall be removed from behind the dam when it has accumulated to one half the original height of the dam.

BUYER CB-23		REQ. OR PO NO. DEP 14397
SPENDING UNIT WEST VIRGINIA DEPARTMENT OF ENVIRONMENTAL PROTECTION/SPECIAL RECLAMATION		

WV-36a STATE OF WEST VIRGINIA
 REV. 5-26-09 PURCHASING CONTINUATION SHEET
 VENDOR:

BID PREPARATION INFORMATION

HISTORICAL INFORMATION

Prospective bidders may review files at the West Virginia Department of Environmental Protection, Charleston, WV office. These files may contain additional information not included in the contract. Documents including, but not limited to, permit applications, permits, inspection reports, environmental documents, permit violation history, geological and geotechnical information, probable hydrologic consequences, maps, modifications, NPDES information and other related data. Copies may be obtained upon request and payment of copying fees.

EXAMINATION OF BID PACKAGE AND SITE OF WORK

The bidder is required to examine, carefully, the bid package (plans, specifications, supplemental specifications, contract forms, etc.) and the site of the work contemplated. The submission of a bid shall be considered prima facie evidence that the bidder has made such examination and has judged for and satisfied themselves as to the character, quantity, and quality of work to be performed and the materials required to be furnished under the contract.

PREBID CONFERENCE

Only the prospective bidders on the sign-in sheet in attendance for the entire Pre-Bid Conference will be eligible to submit bids for consideration of this project. Considerable foot travel over rough terrain and/or inclement weather may be required.

VIDEO

The information given at the pre-bid showing by the project contact person or the assigned person shall be documented on video tape and shall be an integral part of this contract's requirements, but will not supersede the written contract. All information on video tape that is new or provides clarification to the specifications, will be issued in writing by a formal addendum and will become part of the written contract.

INTENT OF CONTRACT

The intent of the contract is for the reclamation/restoration of forfeited mine lands as required by West Virginia Department of Environmental Protection. The contractor is to provide for the construction and completion in every detail of the work described. The Contractor shall furnish all labor, materials, equipment, tools, transportation, and supplies required to complete the work in accordance with the Plans, Specifications, and terms of the Contract.

Should any misunderstanding arise as to the intent or meaning of the Contract, or any discrepancy appear, the decision of the Director of Division of Land Restoration shall be final.

BUYER CB-23		REQ. OR PO NO. DEP 14397
SPENDING UNIT WEST VIRGINIA DEPARTMENT OF ENVIRONMENTAL PROTECTION/SPECIAL RECLAMATION		

WV-36a STATE OF WEST VIRGINIA
REV. 5-26-09 PURCHASING CONTINUATION SHEET
VENDOR:

GENERAL PERFORMANCE STANDARDS

INTRODUCTION

The performance standards and non-compliance penalties which govern special reclamation-bond forfeiture projects are in Chapter 22A, Article 3, of the Code of West Virginia and subsequent rules and regulations. The following performance standards are of a general nature and do not represent all the performance standards applicable to a special reclamation-bond forfeiture project. However, some or all of these standards will pertain to each project.

BACKFILLING

1. Unless otherwise noted, the highwall shall be eliminated and the disturbed area graded to the approximate original contour.
2. The material used to backfill and eliminate the highwall shall be sufficiently compacted so as to insure stability of the backfill throughout the warranty period.
3. The land above the highwall shall not be disturbed unless otherwise directed.
4. The best available material to support vegetation, sufficient to establish a permanent vegetative cover and to achieve the approved post mining land use, shall be used.

BLASTING

The performance standards of the blasting regulations must be adhered to.

LIFE OF CONTRACT

The purchase order contract becomes effective on the starting date as specified in the notice to proceed as issued by the Department of Environmental Protection. This contract extends for a period of one (1) year and may be renewed until such "reasonable time" thereafter as is necessary to complete the payment therefore. A responsible Contractor's Agent shall be on the site at all working times who demonstrates a knowledge of mined land reclamation, contract requirements and responds to DEP (owner) inspections.

WORK PERFORMANCE PERIOD

The work performance period is a defined portion of the contract in which all items shall be completed. The work performance period is to be performed within 365 calendar days. Extensions may be granted based upon contractor's performance, weather conditions and site-specific site conditions.

NOTICE TO PROCEED

A notice to proceed shall be issued to the Contractor by the project contact person for the Department of

BUYER CB-23	REQ. OR PO NO. DEP 14397
SPENDING UNIT WEST VIRGINIA DEPARTMENT OF ENVIRONMENTAL PROTECTION/SPECIAL RECLAMATION	

WV-36a STATE OF WEST VIRGINIA
 REV. 5-26-09 PURCHASING CONTINUATION SHEET
 VENDOR:

Environmental Protection. Actual construction may only begin after a Notice to Proceed is given and as specified. Such notice shall specify the starting date of the Purchase Order, the work performance period, and the completion date of the work performance period.

PRE-CONSTRUCTION CONFERENCE

The Contractor in possession of the awarded purchase order shall schedule a Pre-Construction Conference on the site within ten (10) days after receiving the Notice To Proceed. The Contractor's foreman or the on-the-ground supervisor must be in attendance.

GENERAL SUPERVISION

This contract is under the general supervision of the West Virginia Department of Environmental Protection's contact person for the purpose of contract compliance inspection only. Contractor shall supervise work being conducted at all times. All services rendered by the Engineer/Contact Person consist of professional opinions and recommendations made in accordance with generally accepted engineering practice. Under no circumstances is it the intent of the Engineer/Contact Person to directly control the physical activities of the Contractor or the Contractor's workmen's accomplishment of work on this project.

CONTRACTOR RESPONSIBILITY

The contractor is responsible for compliance with all aspects of this written contract. No changes will be honored without prior approval from the Program Supervisor.

LAWS TO BE OBSERVED

The Contractor shall keep fully informed of all Federal and State laws, all local laws, ordinances, and regulations and all orders and decrees of bodies or tribunals having any jurisdiction or authority, which in any manner affect those engaged or employed on the work, or which in any way affect the conduct of the work. The Contractor shall at all times observe and comply with all such laws, ordinances, regulations, orders and decrees; and shall protect and indemnify the State and its representatives against any claim or liability arising from or based on the violation of any such laws, ordinances, regulations, orders, or decrees, whether by themselves, their subcontractors or their employees.

PERMITS, LICENSES AND TAXES

The Contractor shall procure all permits and licenses, pay all charges, fees, and taxes, and give all notices necessary and incidental to the due and lawful prosecution of the work.

CONCURRENT RECLAMATION

Reclamation of this project shall commence at a definite point as defined and shall progress from that point with total reclamation to include backfilling, grading/regrading, and revegetation. Changes may be granted based upon weather or differing site conditions with prior approval.

WATER QUALITY CONTROL

Shall commence with initial start-up of the project and remain in effect for the extent of the backfilling, regrading and revegetation activity. DEP obtains a storm water permit for each project from the Water Resources

BUYER CB-23		REQ. OR PO NO. DEP 14397
SPENDING UNIT WEST VIRGINIA DEPARTMENT OF ENVIRONMENTAL PROTECTION/SPECIAL RECLAMATION		

WV-36a STATE OF WEST VIRGINIA
REV. 5-26-09 PURCHASING CONTINUATION SHEET
VENDOR:

Division. (General Water Pollution Control Permit WVO115924) The Contractor is responsible for performing the best management practices. Adequate facilities shall be installed, operated and maintained using the best management practices of the U.S. Environmental Protection Agency's Non-Point Source (NPS) Program for sediment control during the active reclamation. The contractor shall take any and all steps necessary to prevent erosion or silting problems from occurring and to minimize pollution or sedimentation of the stream. If any such problems develop, the contractor shall be responsible to take immediate corrective action. No separate payment for this work will be honored. All impounded waters which require removal during reclamation, shall be pumped with appropriate measures taken to prevent erosion from the discharge. The contractor shall be responsible for treatment of said waters to meet pH standards. The water shall be discharged only when the quality meets a pH equivalent to the pH of the receiving stream but not less than 6.0.

DIFFERING SITE CONDITIONS

During the progress of the work, if subsurface or latent physical conditions are encountered at the site differing materially from those indicated in the contract or if unknown physical conditions of an unusual nature, differing materially from those ordinarily encountered and generally recognized as inherent in the work provided by the contract, are encountered at the site, the party discovering such conditions shall promptly notify the other party in writing of the specific differing conditions before they are disturbed and before the affected work is performed.

Upon written notification, the Engineer/Contact Person will investigate the conditions, and if determined that the conditions materially differ and cause an increase or decrease in the cost or time required for the performance of any work under the contract, an adjustment, excluding loss of anticipated profits, will be made and the contract modified in writing accordingly. The Engineer/Contact Person will notify the Contractor of DEP's determination whether or not an adjustment of the contract is warranted.

No contract adjustment which results in a benefit to the Contractor will be allowed unless the Contractor has provided the required written notice.

No contract adjustment will be allowed under this clause for any effects caused on unchanged work.

HANDLING AND STORAGE OF MATERIALS

Materials which are stored on site, before utilization, shall be stored so as to assure the preservation of their quality and fitness for the work. Stored materials, even though approved before storage, may be inspected again prior to their use in the work. Damaged or deteriorated materials shall be removed and replaced by materials meeting the original specifications.

Aggregate stockpiles shall be made on ground that is denuded of vegetation, hard, and well drained. Removal of aggregate from the stockpile shall be done in a manner which will not result in the inclusion of foreign material into the aggregate. The use of the aggregate will determine if exceptions are permitted.

All materials shall be handled in such a manner as to preserve their quality and fitness for the work.

MAINTENANCE DURING CONSTRUCTION

The contractor shall maintain the work during construction and until the project is accepted. All cost of maintenance work during construction and before the project is accepted shall be included in the unit or lump sum prices on the various pay items.

FINAL INSPECTION

A final inspection meeting by the Department of Environmental Protection's Specialist and the contractor is

BUYER CB-23	REQ. OR PO NO. DEP 14397
SPENDING UNIT WEST VIRGINIA DEPARTMENT OF ENVIRONMENTAL PROTECTION/SPECIAL RECLAMATION	

WV-36a STATE OF WEST VIRGINIA
REV. 5-26-09 PURCHASING CONTINUATION SHEET
VENDOR:

required for the construction phase and prior to demobilization.

ACREAGE QUANTITIES

The acreage quantities in this contract are for bidding purpose and are set (definite) number for the project area as specified at the pre-bid showing. Only surveyed acreage's through figures the Contractor and/or the State develops will be honored to alter these acreage numbers.

PAYMENT

Invoices must be submitted on prescribed Department of Environmental Protection, Special Reclamation Program forms and include verification. Certified contractor payrolls for operators directly involved in this project and a current workers compensation certificate must accompany each invoice for payment. Verification of wage rates may include employee interviews. Invoices shall be signed in blue ink so that it is easy to verify that document is an original. Vendor should submit with their bid the current remit-to address to be used for payment processing.

MOBILIZATION/DEMobilIZATION shall be invoiced at fifty percent (50%) with the first invoice and the last 50% invoiced after demobilization and acceptance of the road abandonment or final invoice. Demobilization must have written approval.

SPILL CONTAINMENT AREA shall not exceed \$1,000.00 and will be payable in two payments. The first fifty percent (50%) payable with the first invoice and the remainder payable when all fuel tanks, containers and etc., are removed from the site.

Lump sum items shall be percentage payments based on work completed at time of invoice and paid upon acceptance by the Department of Environmental Protection.

Unit items shall be invoiced by specified units completed and accepted by the DEP.

ROAD ABANDONMENT shall be included in the final construction invoice.

FAILURE TO COMPLETE ON TIME AND LIQUIDATED DAMAGES

Time is an essential element of the Contract and it is important that the work be completed within the time specified. The cost to the Department of the administration of the Contract, including engineering, inspection and supervision, will increase as the time required to complete the work is increased.

The work performance period as specified in the contract's Notice to Proceed shall be complied with or result in liquidated damages. Such damages shall be assessed at an amount of two hundred and fifty dollars (\$250.00) per day for each and every day beyond the work performance period as specified in the Notice to Proceed. The total amount of daily charges will be deducted from any moneys due the Contractor, not as a penalty but as liquidated damages.

REVEGETATION AND WARRANTY

The seeding date shall be at the discretion of the contractor once an approved seedbed has been prepared. In all cases a permanent vegetative cover capable of supporting the post-mining land use must be established. A warranty period of one (1) year shall commence upon completion and payment of the revegetation item of the contract. No payment will be made for additional seeding necessary to comply with warranty requirements. The warranty period will be extended for one (1) year from the date of the last augmented seeding done by the contractor. The performance bond and labor and materials bond shall remain in effect throughout the warranty period. The Standards for Evaluating Vegetative Cover as presented in Title 38, CSR2, Section 9 of the West Virginia Surface Mining Reclamation Regulations will apply.

Equipment for the retracking/scarification to eliminate rills and gullies shall be mobilized and utilized to

BUYER CB-23	REQ. OR PO NO. DEP 14397
SPENDING UNIT WEST VIRGINIA DEPARTMENT OF ENVIRONMENTAL PROTECTION/SPECIAL RECLAMATION	

WV-36a STATE OF WEST VIRGINIA
REV. 5-26-09 PURCHASING CONTINUATION SHEET
VENDOR:

produce slopes consistent with the regrading and topsoiling bid item prior to warranty reseeding. No additional payment will be made by DEP for this warranty work.

Water utilized for hydroseeding shall be free of injurious or other toxic substances harmful to plant life. The source of water is subject to the approval of the DEP contact person.

CONTRACT NON-COMPLIANCE

If in the opinion of the Department of Environmental Protection the contract is not in compliance with any line item specification, that portion of the project shall cease until a compliance schedule and understanding is demonstrated in writing and accepted by the Director of Division of Land Restoration.

CONTRACT DELETIONS

Any line item, or any portion thereof, may be deleted when determined by the project contact person that such line item, or portion thereof, is deemed unnecessary for the successful reclamation of this project. No claim for loss of anticipated profits will be considered.

CANCELLATION

The performance of work under contract may be terminated by the State in whole, or from time to time in part whenever the State shall determine that such termination is in the best interest of the State. Any such termination shall be effected by delivery to the Contractor of a Notice of Termination specifying the extent to which performance of work under the Contract is terminated and the date upon which such termination becomes effective.

When contracts, or any portion thereof, are terminated before completion of all items of work in the Contract, payment will be made for the actual number of units or items of work completed and accepted at the contract unit price. No claim for loss of anticipated profits will be considered. Reimbursement for organization of the work, when not otherwise included in the Contract, and moving equipment to and from the job will be considered where the volume of work completed and accepted is too small to compensate the Contractor for these expenses under the contract unit prices, the intent being that an equitable settlement will be made with the Contractor.

Termination of the Contract or a portion thereof shall not relieve the Contractor of his responsibilities for the completed work, nor shall it relieve his surety of its obligation for and concerning any just claims arising out of the work performed.

This contract may be cancelled in whole or in part in writing by the Director of Purchasing, without prejudice to any other right or remedy it may have, provided that the contractor is given not less than thirty (30) calendar days written notice, (delivered by certified mail, return receipt requested) of intent to terminate. This contract objective is to comply with the reclamation laws of this state and must be expedient to meet the time requirements for reclamation of revoked surface mine permits.

BUYER CB-23	REQ. OR PO NO. DEP 14397
SPENDING UNIT WEST VIRGINIA DEPARTMENT OF ENVIRONMENTAL PROTECTION/SPECIAL RECLAMATION	

WV-36a STATE OF WEST VIRGINIA
 REV. 5-26-09 PURCHASING CONTINUATION SHEET
 VENDOR:

S

Attn:

Re: Notice to Proceed
 Permit Name: _____
 Permit No. _____
 Purchase Order No.: DEP

Dear :

The purpose of this letter is to express our appreciation for your work in advance and to recognize a reclamation partnership project. The official starting date for the above mentioned purchase order is . The work performance period must be completed by . The contract life of one year is provided to accomplish all line items and to process all payments within that period.

You must schedule a pre-construction conference on site within ten (10) days after receiving this notice to proceed. It is then mandatory that construction begins within ten (10) days of the pre-construction conference and continues diligently until completion of the project. Please contact this office to schedule the pre-construction conference. The foreman, superintendent, or on-the-ground supervisor must be in attendance at this conference.

Failure to comply with this notice to proceed will cause termination of the contract and forfeiture of your performance bond.

If you have any questions please feel free to contact this office.

L

Sincerely,

E

BUYER CB-23		REQ. OR PO NO. DEP 14397
SPENDING UNIT WEST VIRGINIA DEPARTMENT OF ENVIRONMENTAL PROTECTION/SPECIAL RECLAMATION		

WV-36a STATE OF WEST VIRGINIA
REV. 5-26-09 PURCHASING CONTINUATION SHEET
VENDOR: _____

General Requirements

Project Construction Sign

Work Required

The work to be performed under this Section consists of providing all labor, material and equipment necessary to install a project sign as indicated on the detail included herein and as specified herein.

Materials

Paint. Paint for the project sign shall be one (1) coat Exterior-Grade Wood Primer- Sealer, and two (2) coats Exterior-Grade Enamel by Glidden or equivalent.

Wood. Sign face shall be ¾" X 4' X 8' Marine Exterior plywood, and posts and cross braces shall be treated.

Hardware. All hardware shall be manufactured from good, commercial-quality material and be rust resistant such as galvanized coated.

Execution

Project Sign. The signboard shall be cut to the dimensions shown on the details herein. The sign shall be painted with one (1) coat of primer and two (2) coats of white enamel. All exterior cut edges shall be smooth sanded prior to painting. All edges shall be double primed. The letters, border and strips shall be painted as shown on the detail drawing.

The Contractor shall bolt the sign to posts and provide required cross bracing. The posts and sign shall be erected and posts set in gravel base, as shown on the drawings. One (1) sign is required and is to be located at the direction of WVDEP.

Payment. Payment for the work which shall include installation of the project sign shall be incidental to the lump sum bid item for "Mobilization/Demobilization"

Note: No construction work shall commence prior to the project sign being installed.

BUYER CB-23	REQ. OR PO NO. DEP14397
SPENDING UNIT WEST VIRGINIA DEPARTMENT OF ENVIRONMENTAL PROTECTION/OFFICE OF SPECIAL RECLAMATION	



Joe Manchin, III,
Governor



Randy C Huffman,
Cabinet Secretary



Ken Ellison,
Director

**STATE OF WEST VIRGINIA
DEPARTMENT OF ENVIRONMENTAL PROTECTION**

**Division of Land Restoration
Office of Special Reclamation**

Project Cost: \$XXX,XXX.00
Funding provided by the Special Reclamation Coal Tax paid by WV Coal Mine Companies

Permit Name	Project Start Date: 01/01/01
Permit Number	
Contractor: Joe Smith Contracting	

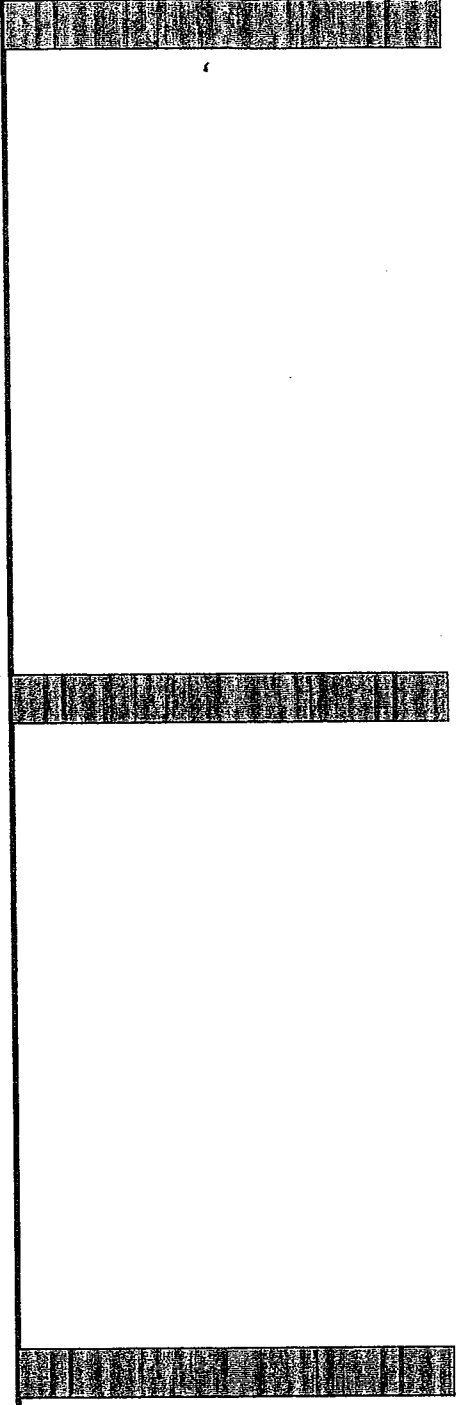

BUYER CB-23	REQ. OR PO NO. DEP14397
SPENDING UNIT WEST VIRGINIA DEPARTMENT OF ENVIRONMENTAL PROTECTION/OFFICE OF SPECIAL RECLAMATION 77 1/4"	

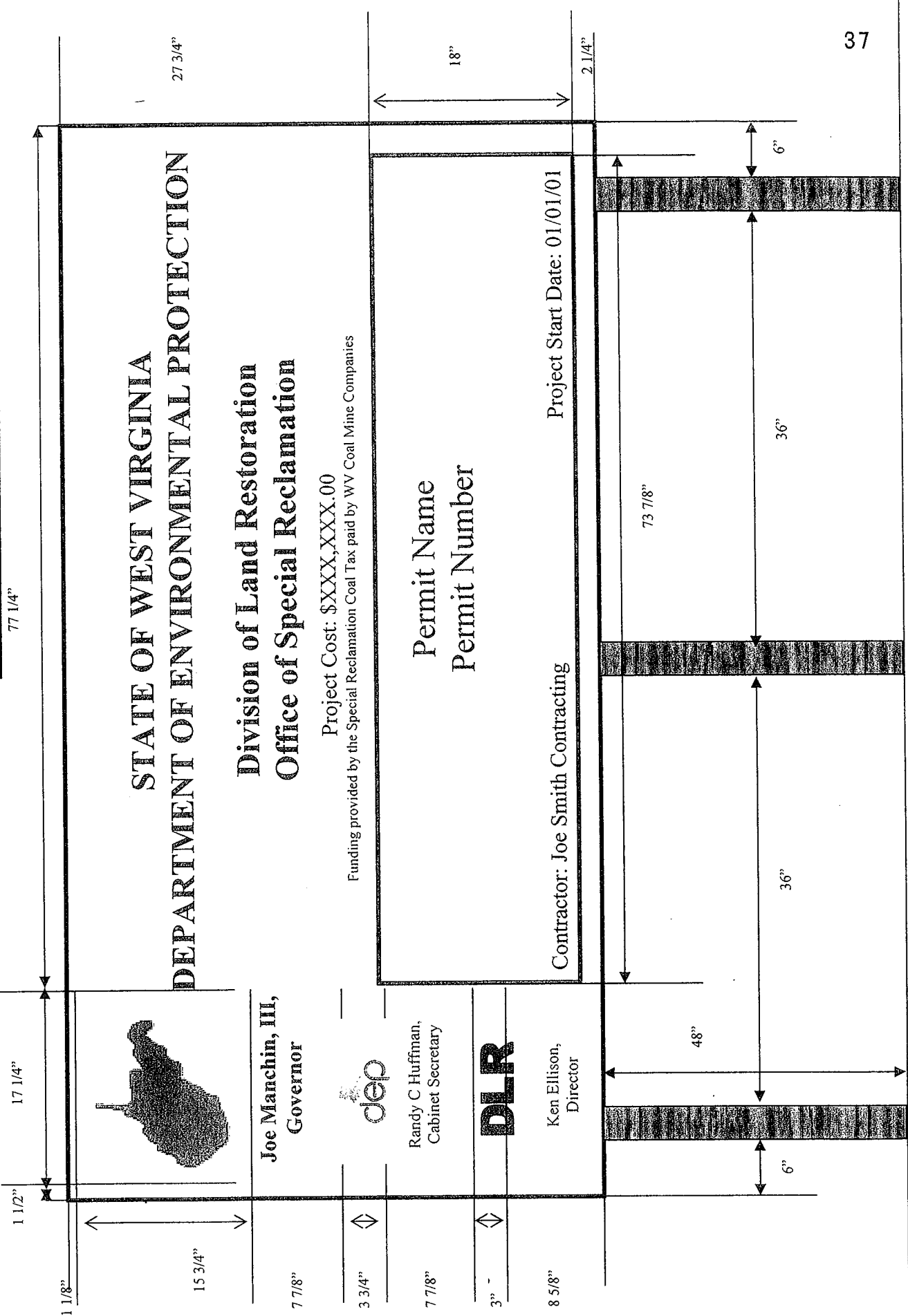

STATE OF WEST VIRGINIA
DEPARTMENT OF ENVIRONMENTAL PROTECTION

Division of Land Restoration
Office of Special Reclamation

Project Cost: \$XXXX,XXX.00
Funding provided by the Special Reclamation Coal Tax paid by WV Coal Mine Companies

Permit Name
Permit Number

Contractor: Joe Smith Contracting
Project Start Date: 01/01/01



Joe Manchin, III,
Governor



Randy C Huffman,
Cabinet Secretary



Ken Ellison,
Director

BUYER CB-23	REQ. OR PO NO. DEP 14397
SPENDING UNIT WEST VIRGINIA DEPARTMENT OF ENVIRONMENTAL PROTECTION/OFFICE OF SPECIAL RECLAMATION	

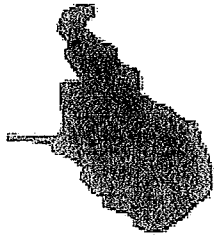

Joe Manchin, III,
Governor



Randy C Huffman,
Cabinet Secretary



Ken Ellison,
Director

**STATE OF WEST VIRGINIA
DEPARTMENT OF ENVIRONMENTAL PROTECTION**

**Division of Land Restoration
Office of Special Reclamation**

Project Cost: \$XXX,XXX.00
Funding provided by the Special Reclamation Coal Tax paid by WV Coal Mine Companies

Permit Name Permit Number	Project Start Date: 01/01/01
------------------------------	------------------------------

Contractor: Joe Smith Contracting

48"

81 3/8"

7 7/8"

9 3/8"

5 1/4"

BUYER CB-23	REQ. OR PO NO. DEP14397
SPENDING UNIT WEST VIRGINIA DEPARTMENT OF ENVIRONMENTAL PROTECTION/OFFICE OF SPECIAL RECLAMATION	



Joe Manchin, III,
Governor



Randy C. Huffman,
Cabinet Secretary



Ken Ellison,
Director

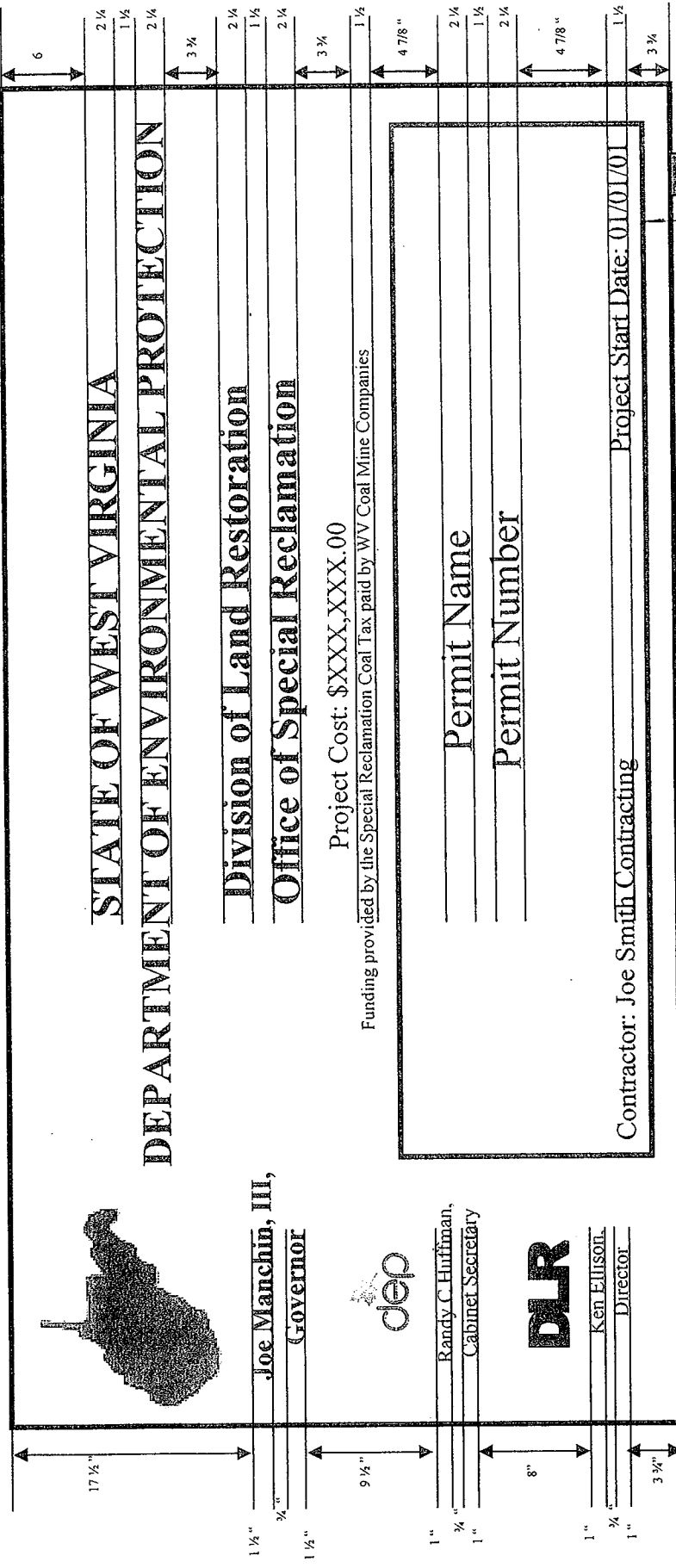

BUYER CB-23	REQ. OR PO NO. DEP 14397
SPENDING UNIT WEST VIRGINIA DEPARTMENT OF ENVIRONMENTAL PROTECTION/OFFICE OF SPECIAL RECLAMATION	

Notes:

1. Sign Board to be 3/4" by 4' X 8' Marine Plywood
2. Sign Board Color is to be White and Letter Colors are to be Dark Green
3. 2" X 4" Treated Cross Brace Let into Posts
4. Mount sign to Posts using 3/8" X 5" Galvanized Carriage Bolts
5. Posts are to be Treated 4" X 4" X 12'
6. Location determined WVDEP

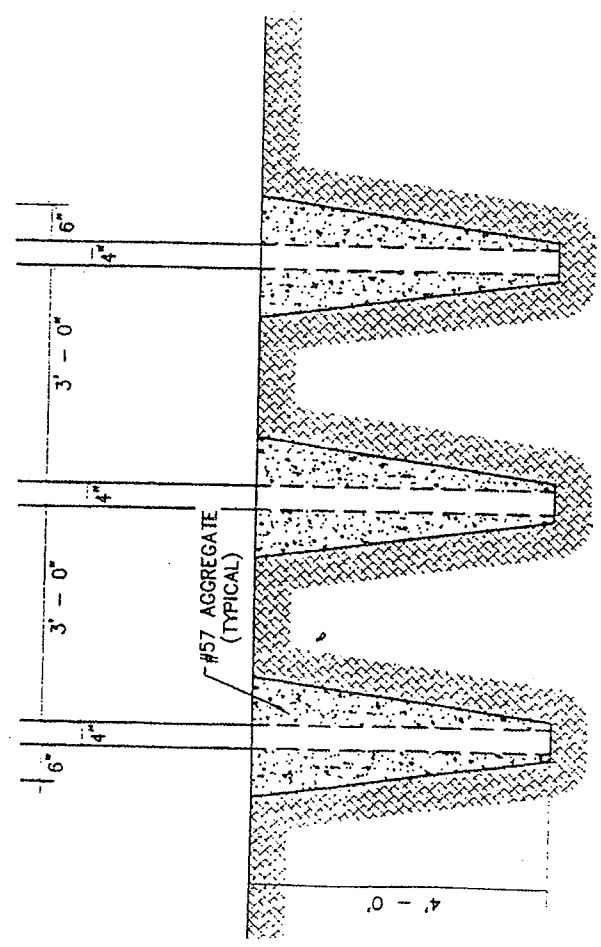
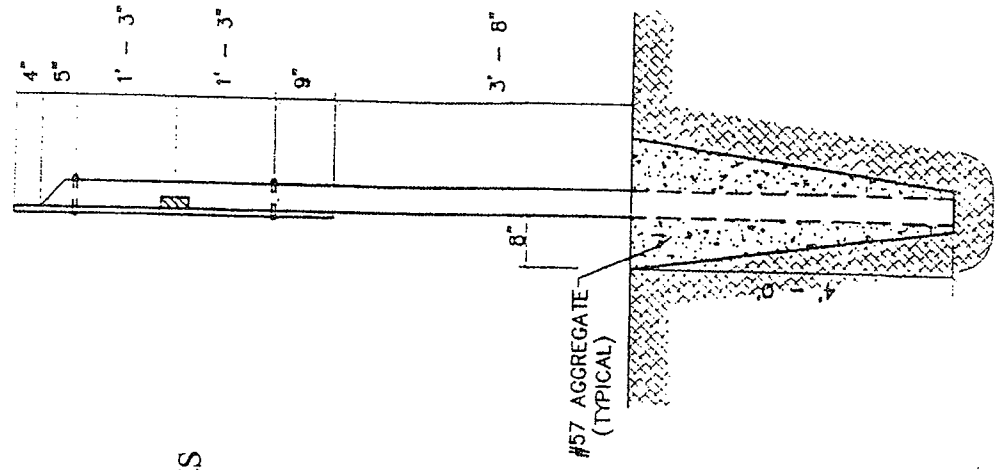



BUYER
CB-23

REQ. OR P.O. No
DEP 14397

SITE PLAN

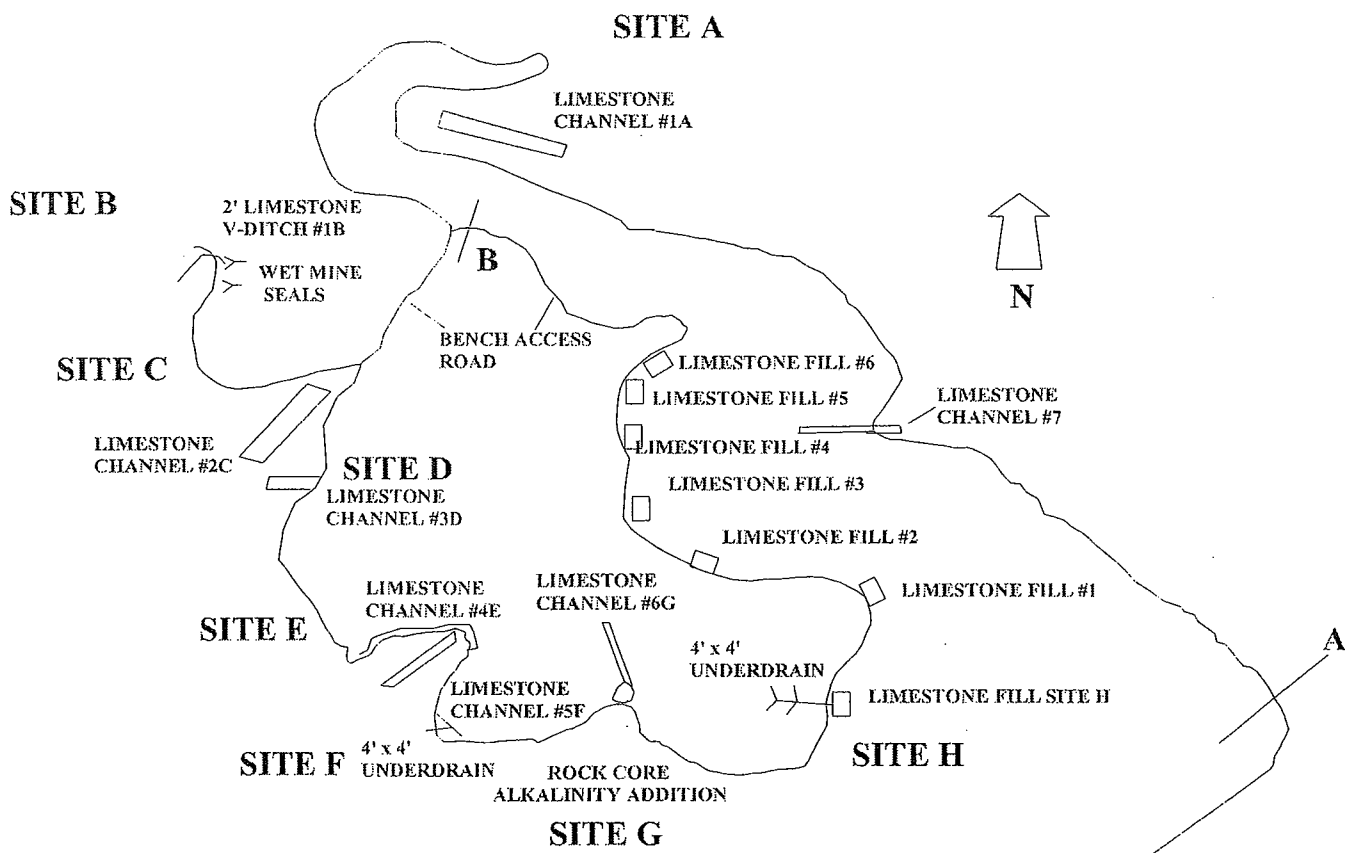

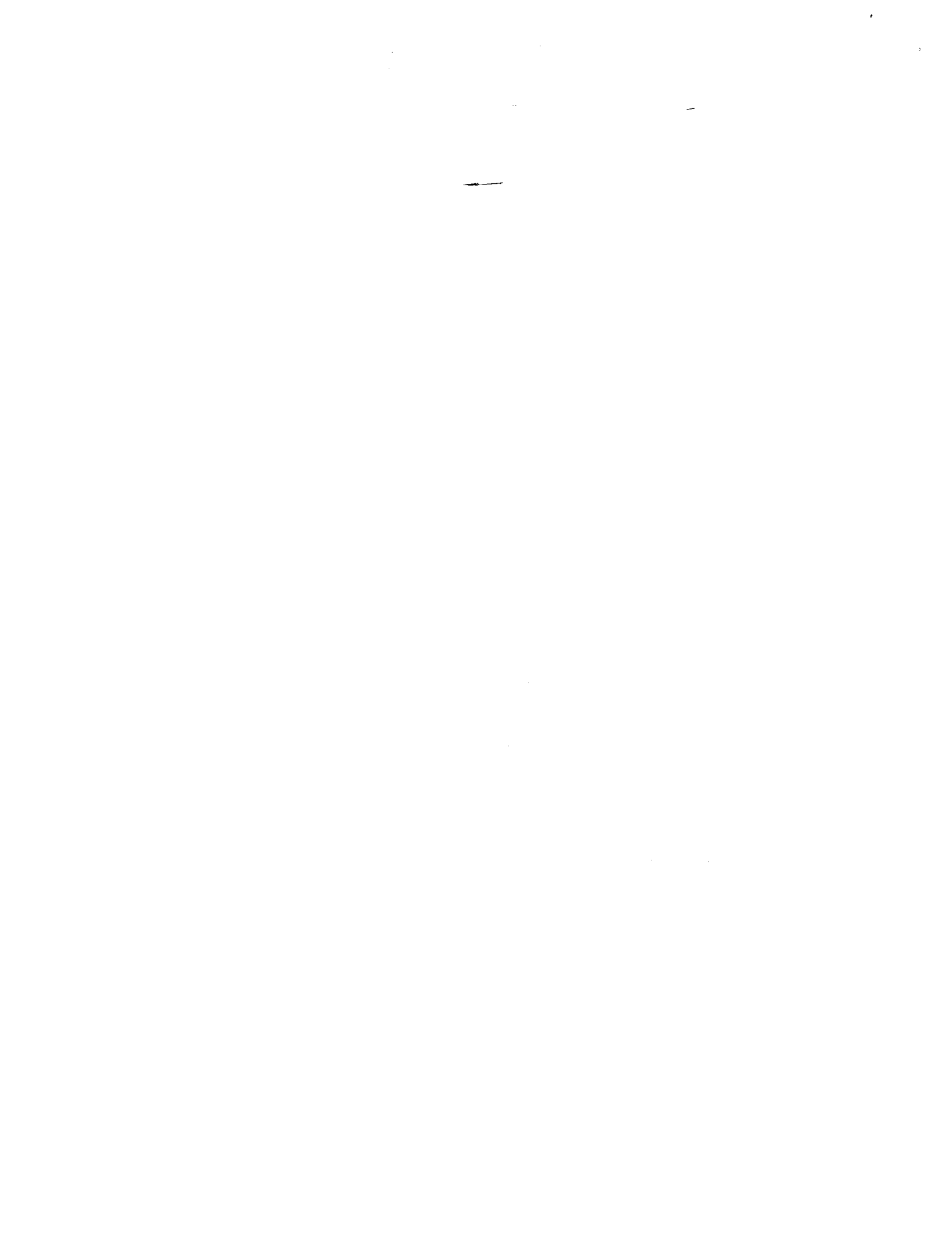

BUYER CB-23	REQ or P.O. No. DEP 14397
----------------	------------------------------

SEDIMENT CONTROL PLAN

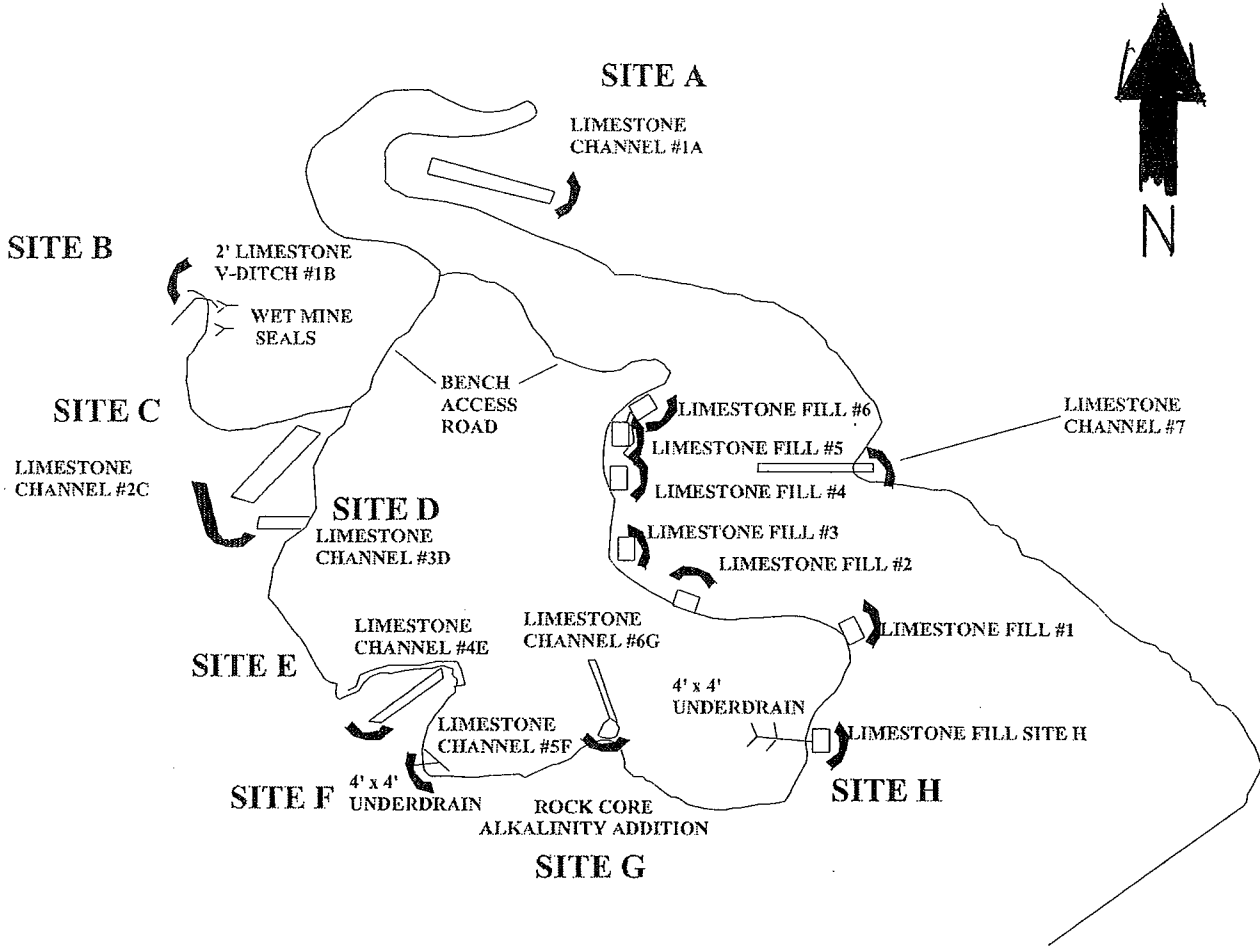

 = NOTE: This symbol is used to denote Locations of SEDIMENT CONTROLS on PERMIT AREAS

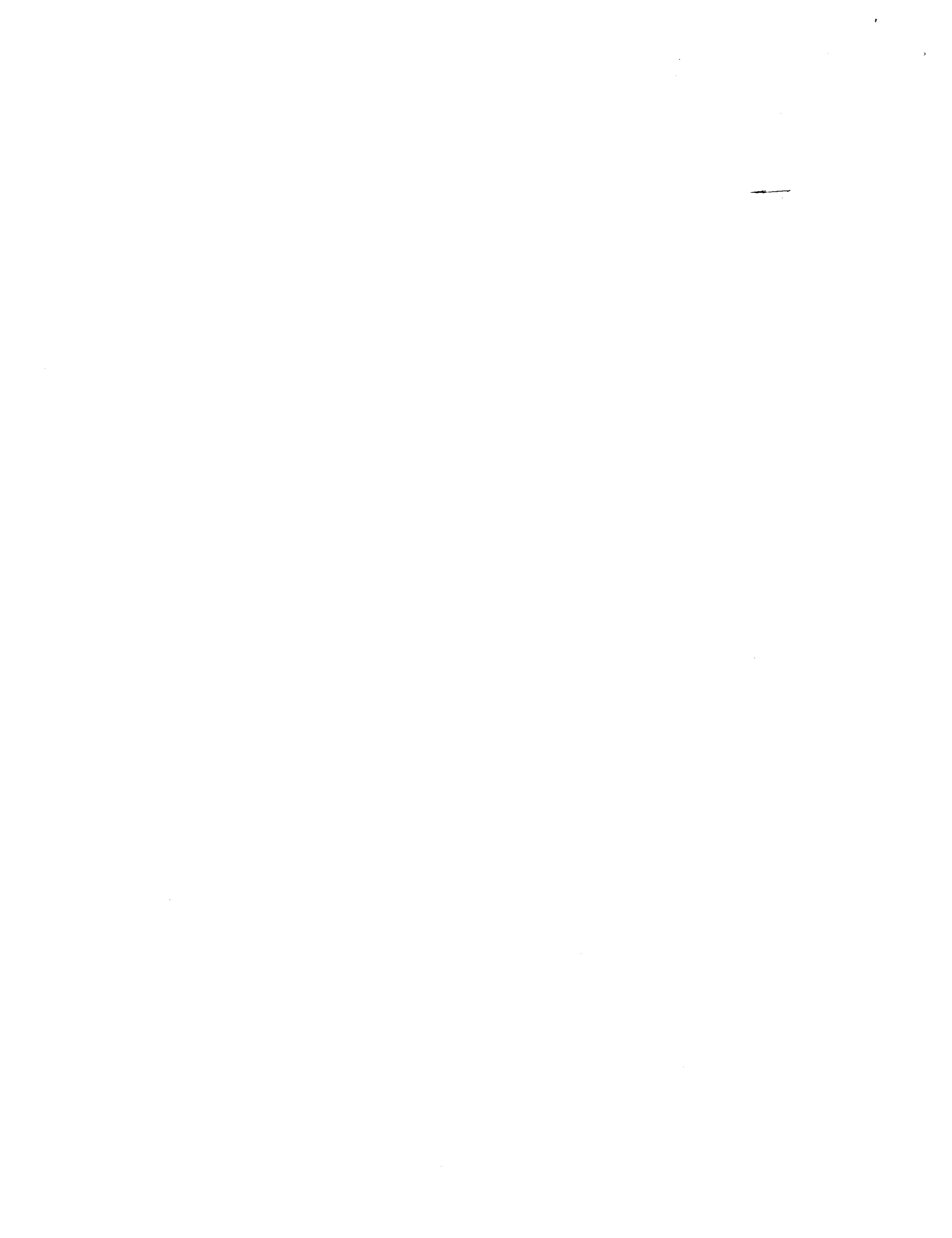

BUYER
CB-23

REQ. or P.O. No. DEP
14397

CHANNEL 1A SITE PLAN

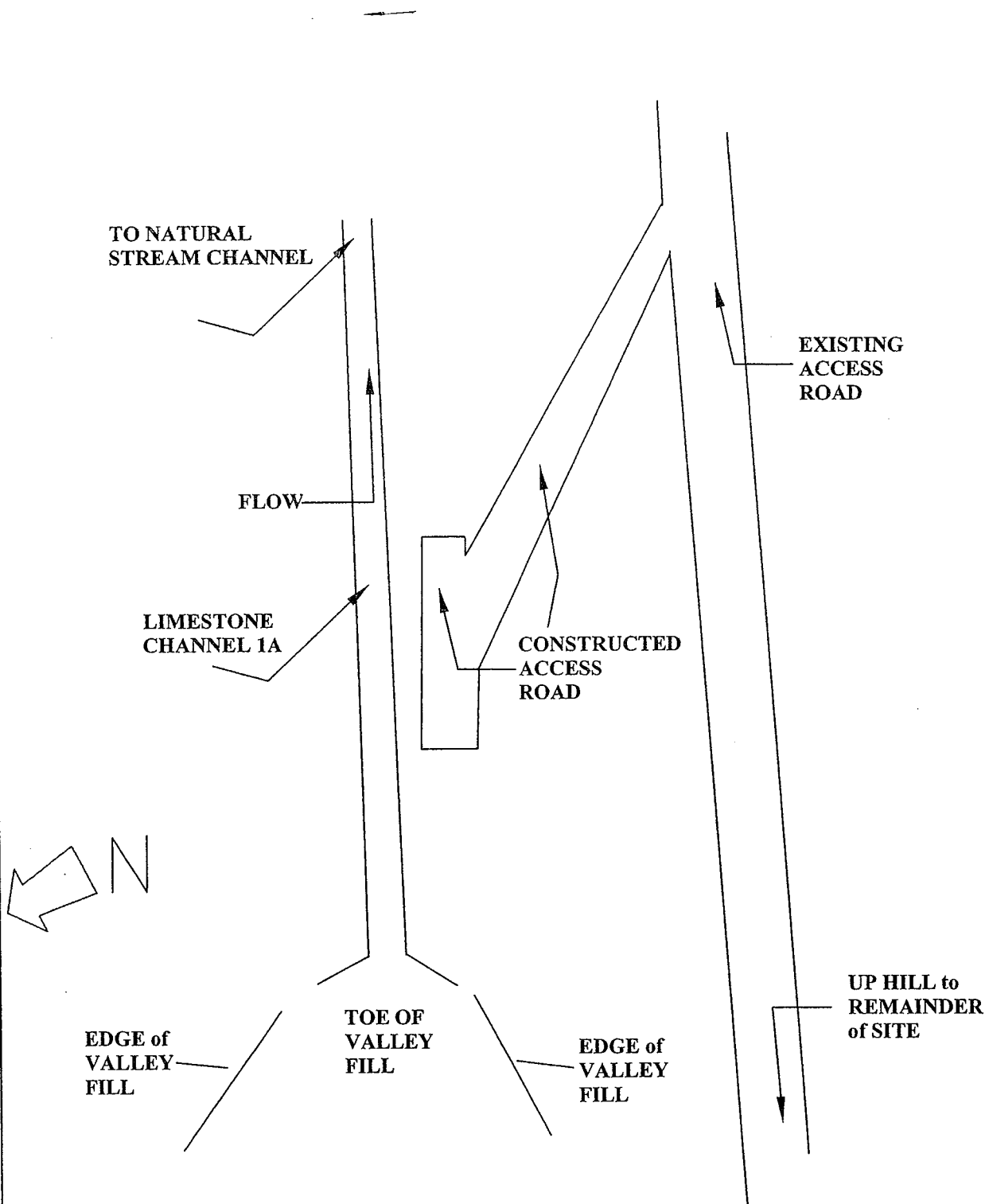

NOTE: ACCESS ROAD WILL BE CONSTRUCTED PER SPECIFICATIONS LISTED ON ACCESS ROAD TYPICAL.

BUYER CB-23	REQ. or P.O. No. DEP 14397
----------------	-------------------------------

2' V-DITCH 1B, MINE SEALS PLAN

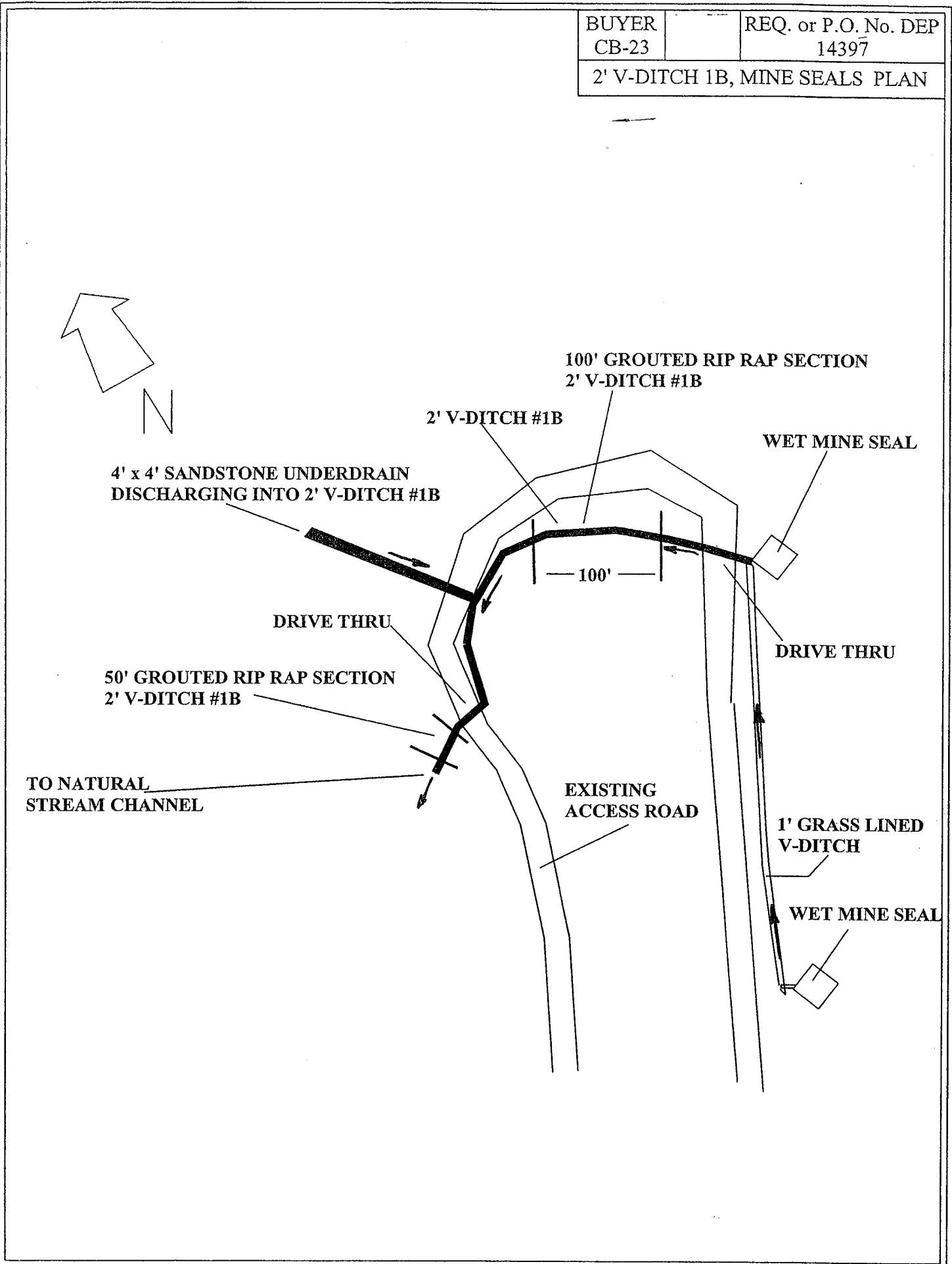

BUYER CB-23	REQ. or P.O. No. DEP 14397
----------------	-------------------------------

CHANNEL 2C SITE PLAN

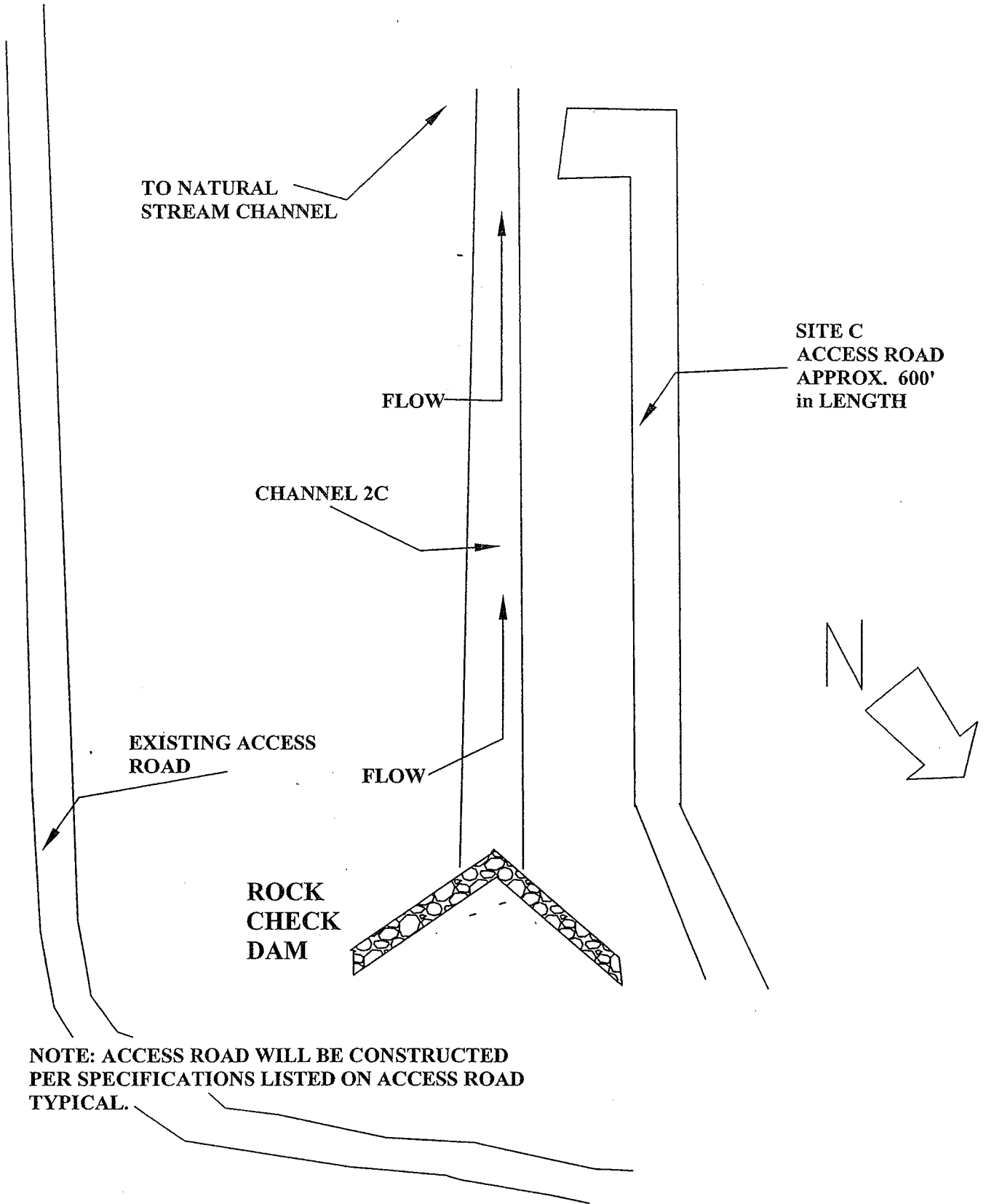

NOTE: ACCESS ROAD WILL BE CONSTRUCTED PER SPECIFICATIONS LISTED ON ACCESS ROAD TYPICAL.

BUYER CB-23	REQ. or P.O. No. DEP 14397
ROCK CHECK DAM DETAILS	

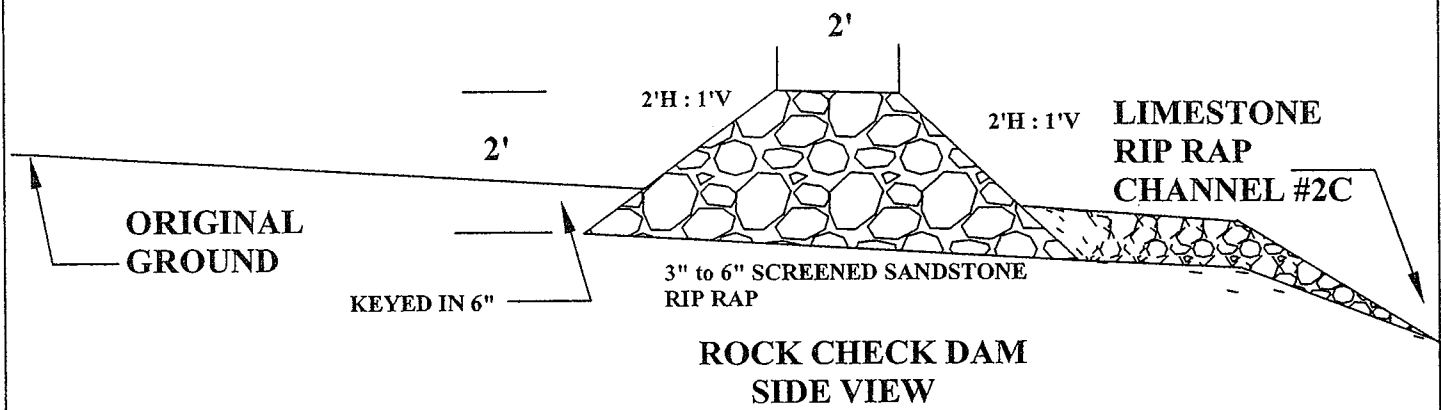

ROCK CHECK DAM
SIDE VIEW

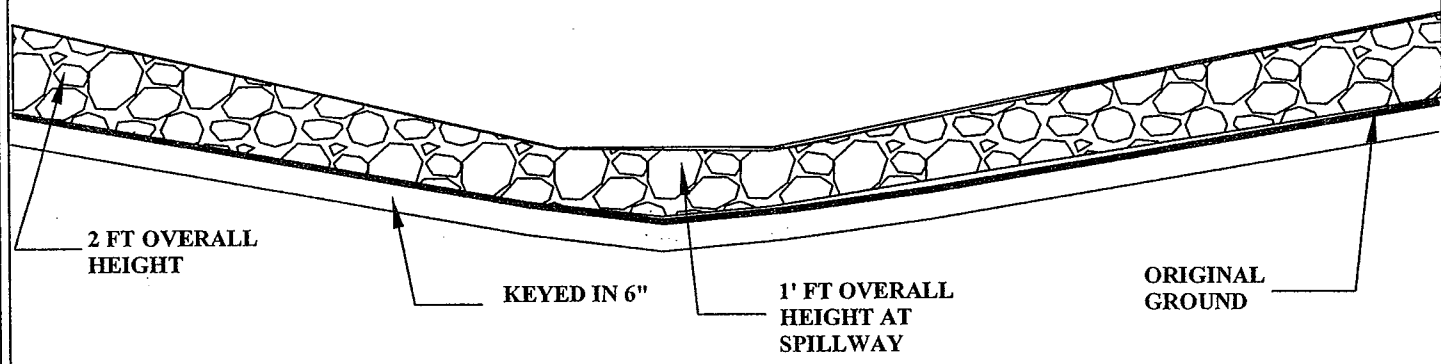

ROCK CHECK DAM
FRONT VIEW

BUYER
CB-23

REQ. or P.O. No. DEP
14397

CHANNEL 3D, SITE D PLAN

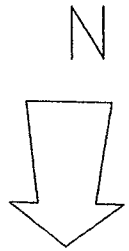
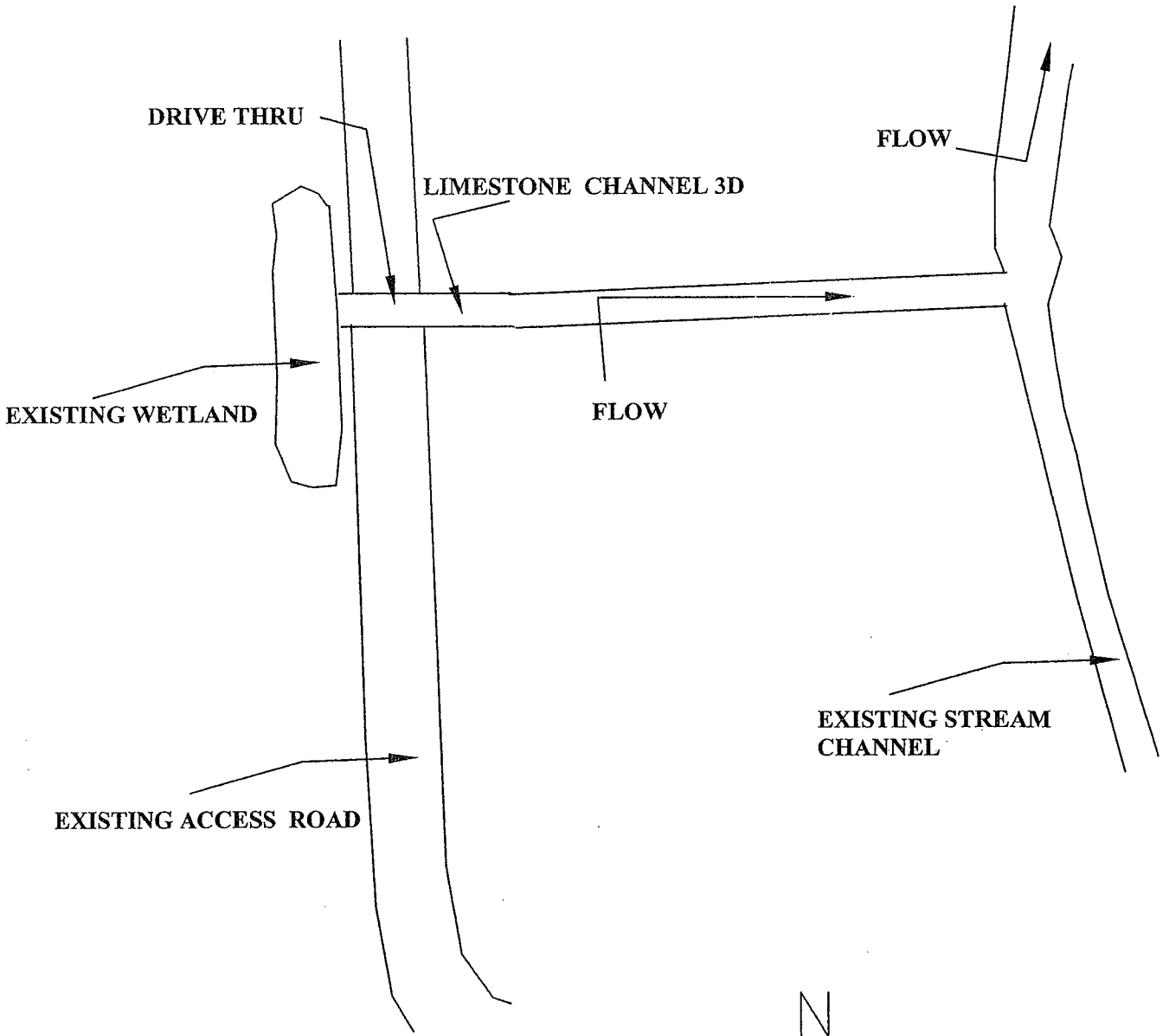

BUYER	REQ. or P.O. No. DEP
CB-23	14397

SPILLWAY from WETLAND to 3D

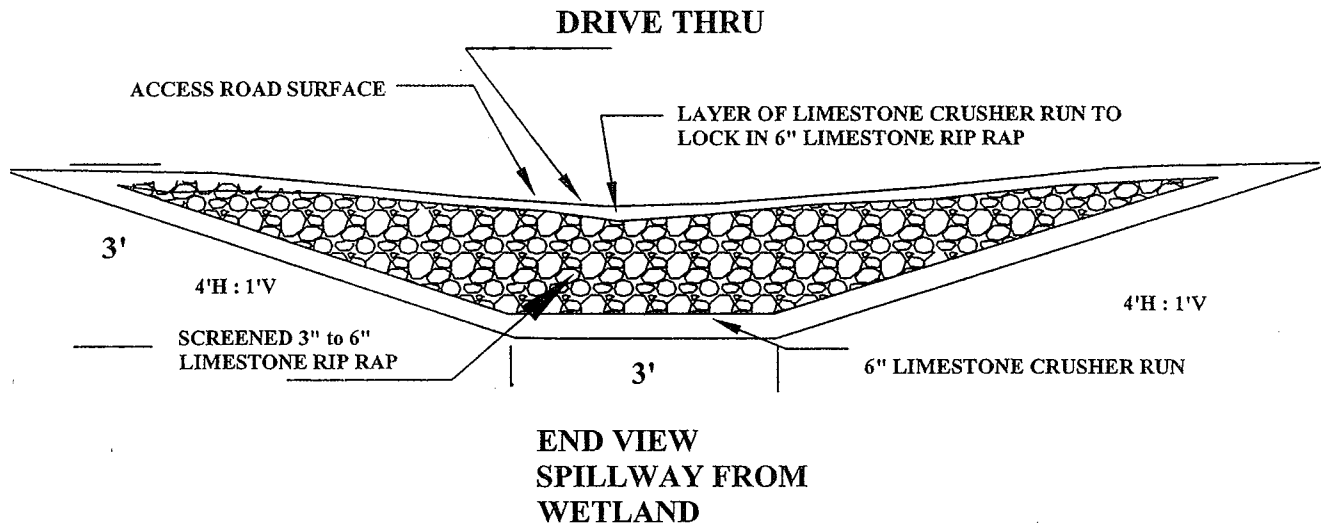

**SIDE VIEW WETLAND
and SPILLWAY**

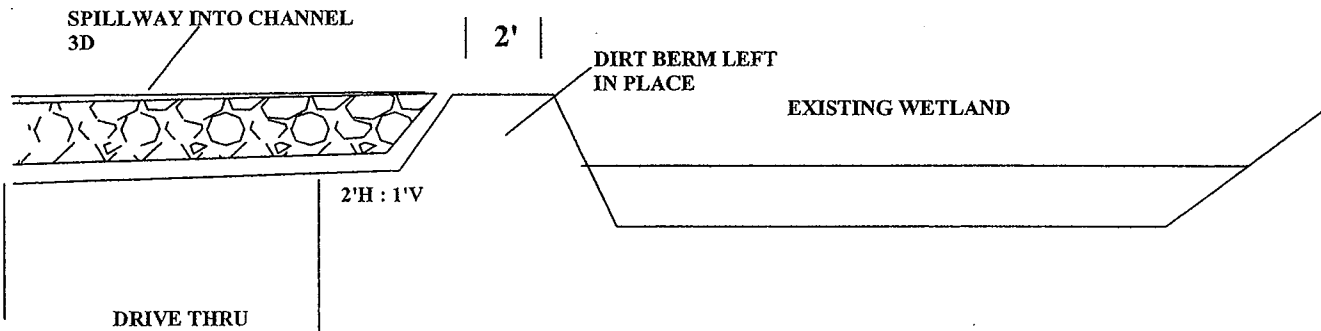

BUYER CB-23	REQ. or P.O. No. DEP 14397
SITE F SITE PLAN	

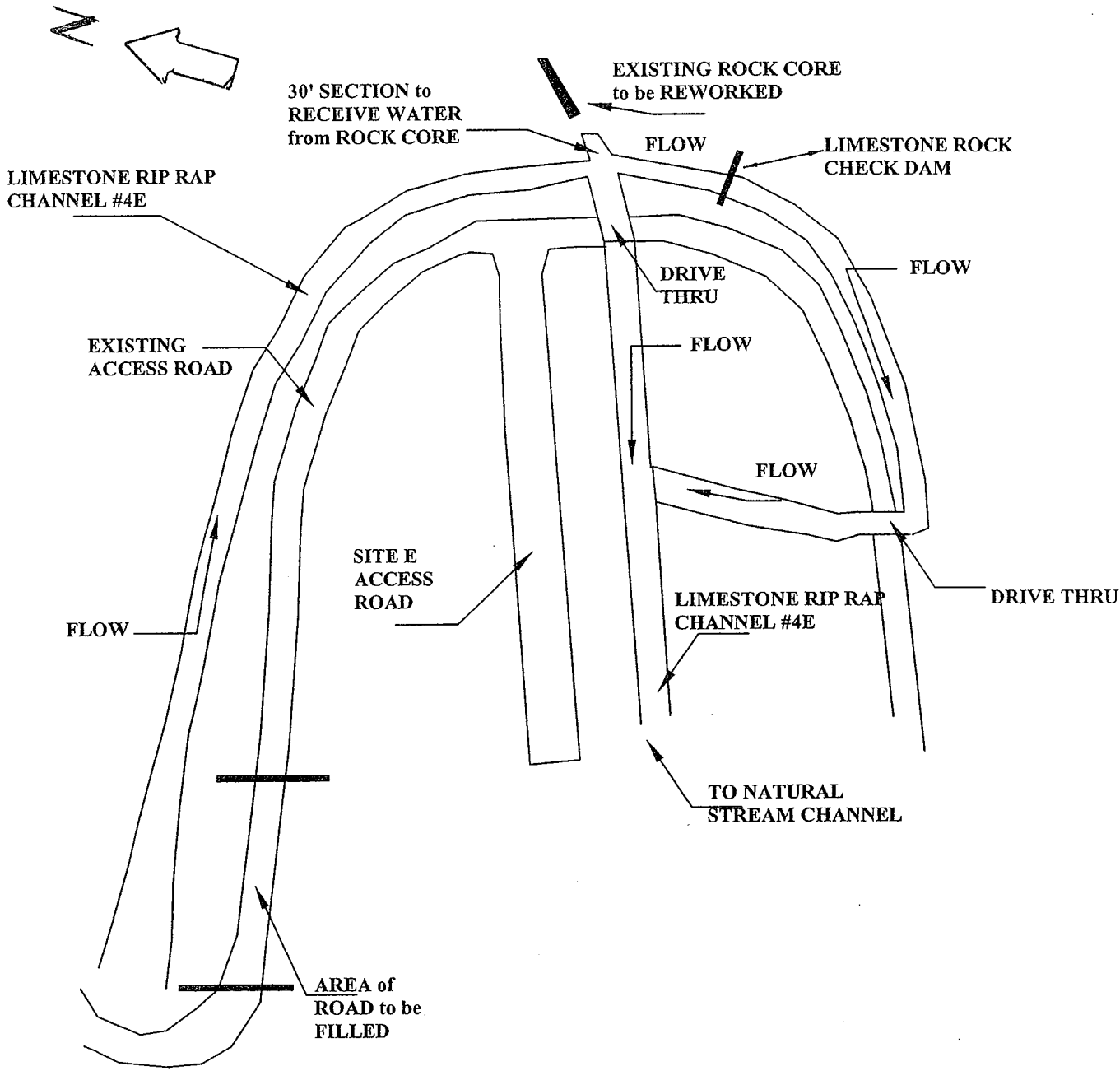

BUYER
CB-23

REQ. or P.O. No. DEP
14397

SITE F SITE PLAN

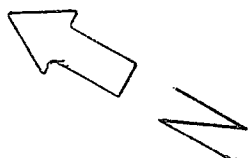

TO CHANNEL 4E

EXISTING
ACCESS ROAD

LIMESTONE FILL AREA
with a 6" LAYER of 3" LS
CRUSHER RUN

CHANNEL #5F on
top of
UNDERDRAIN

DRIVE THRU

2' x2' LIMESTONE
UNDER DRAIN

**NOTE: CHANNEL will
be CONSTRUCTED of
3" to 6" LIMESTONE
RIP RAP**

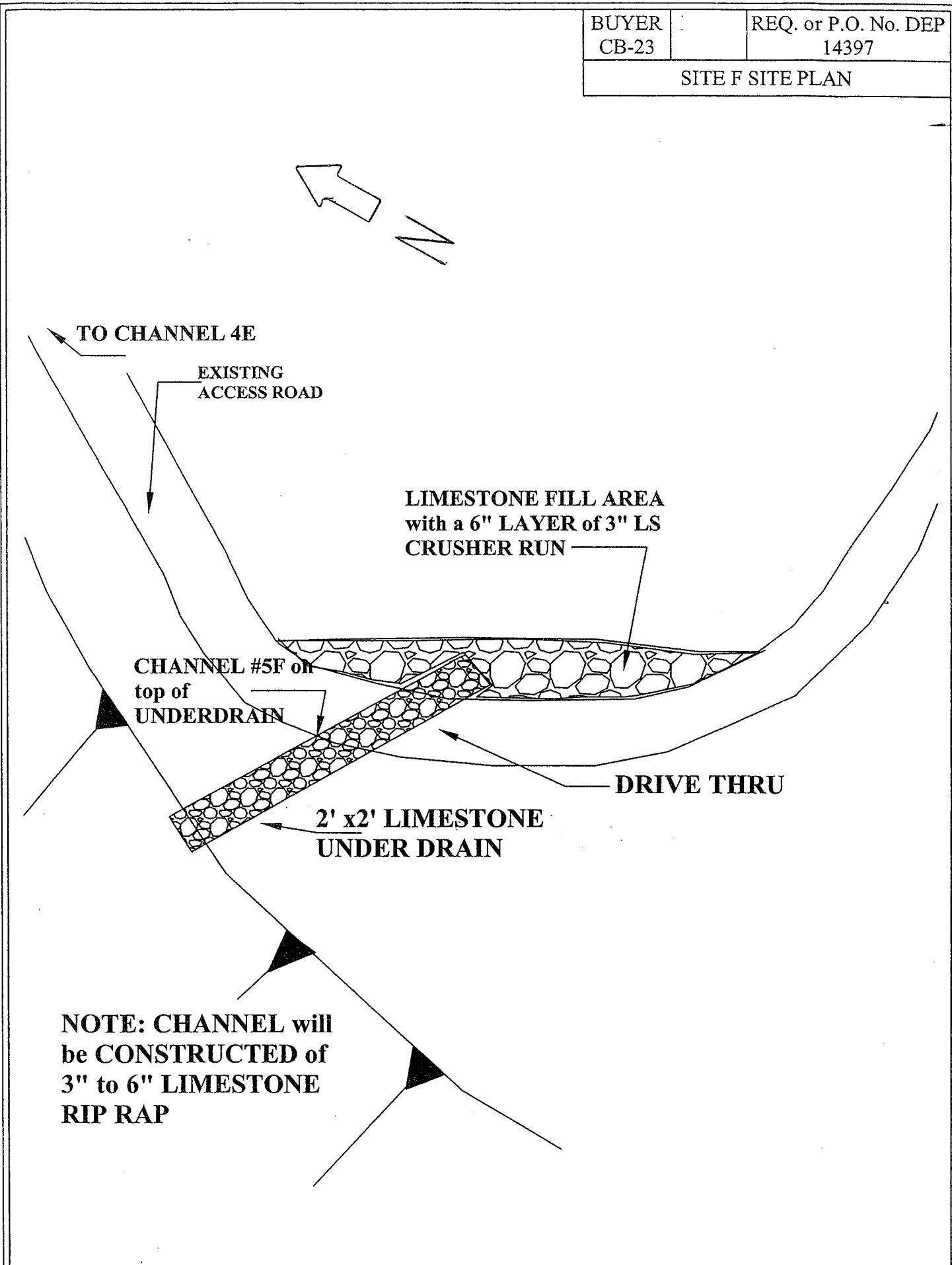

BUYER
CB-23

REQ. or P.O. No. DEP
14397

CHANNEL #5F/ UNDERDRAIN

CHANNEL #5F

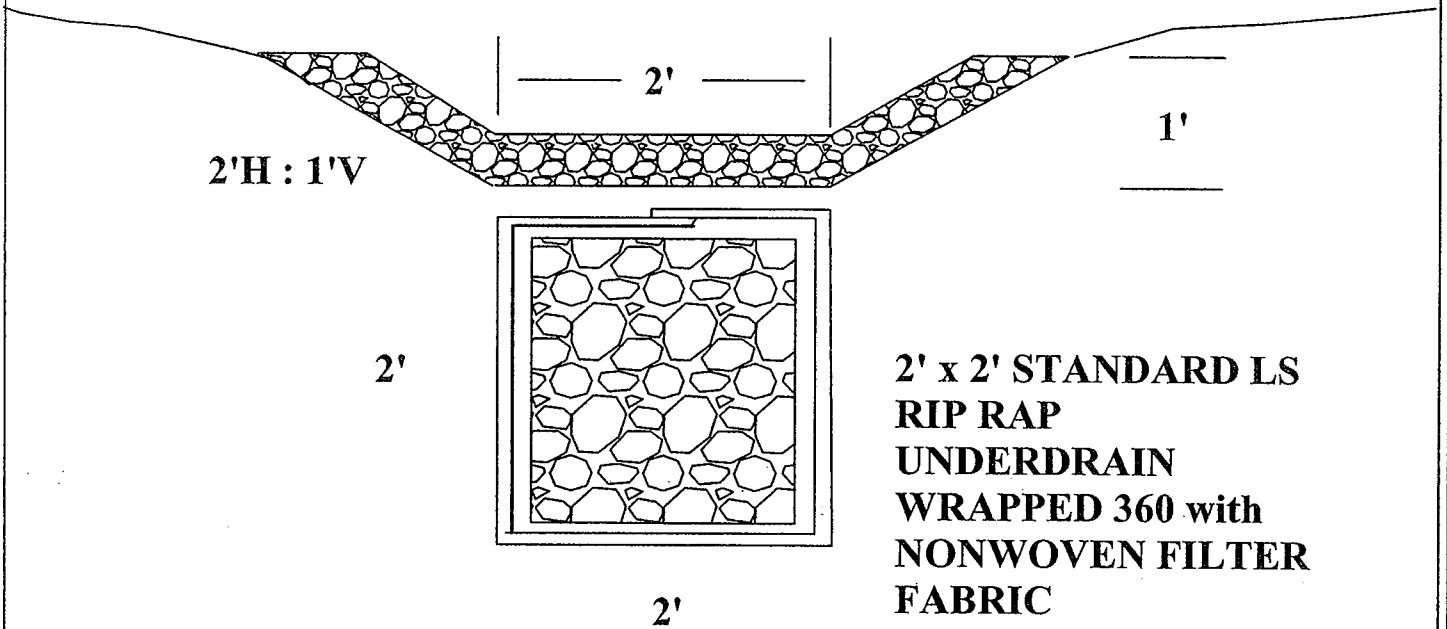

**NOTE: CHANNEL will
be CONSTRUCTED of
3" to 6" LIMESTONE
RIP RAP 18" THICK**



BUYER CB-23	REQ. or P.O. No. DEP 14397
CHAN 5F UNDERDRAIN DRIVE THRU	

**CHANNEL #5F
DRIVE THRU**

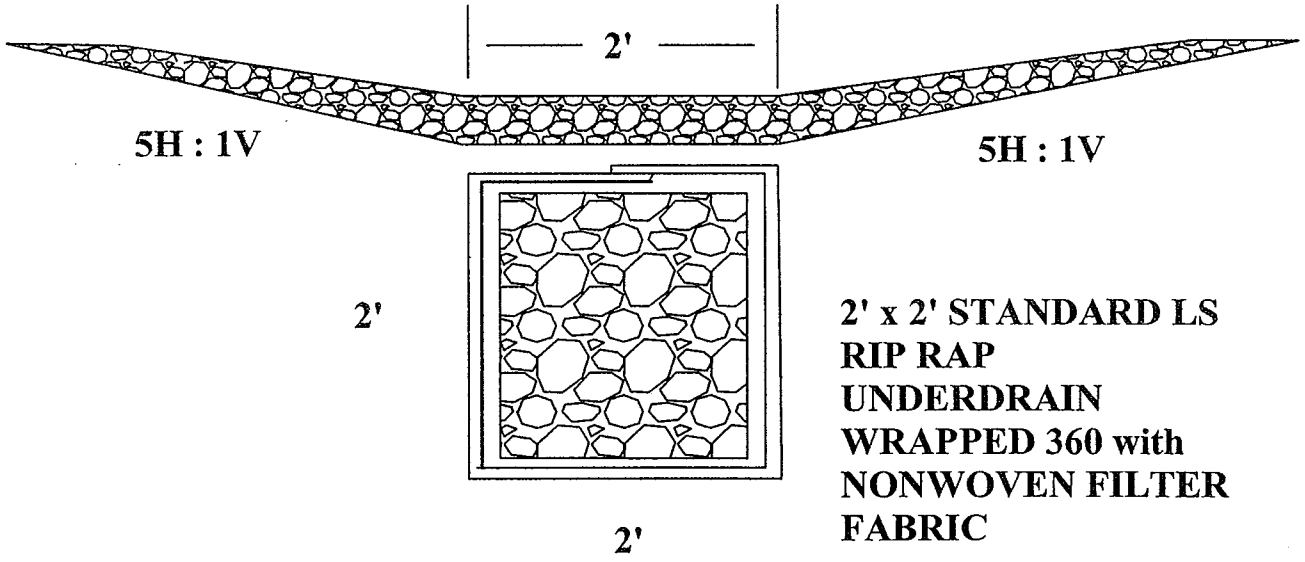

**NOTE: CHANNEL will
be CONSTRUCTED of
3" to 6" LIMESTONE
RIP RAP 18" THICK**

**2' x 2' STANDARD LS
RIP RAP
UNDERDRAIN
WRAPPED 360 with
NONWOVEN FILTER
FABRIC**

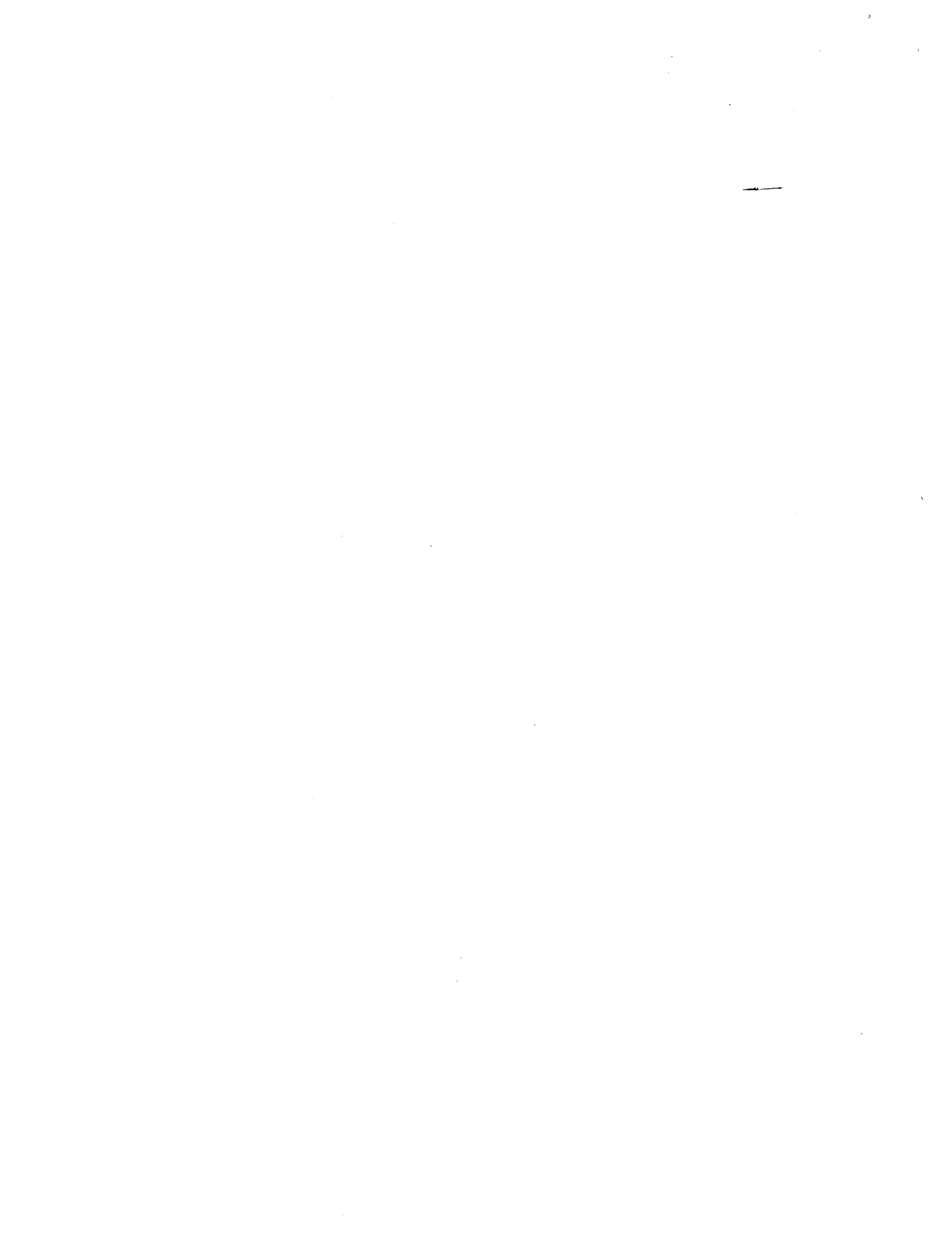

BUYER CB-23	REQ. or P.O. No. DEP 14397
SITE G SITE PLAN	

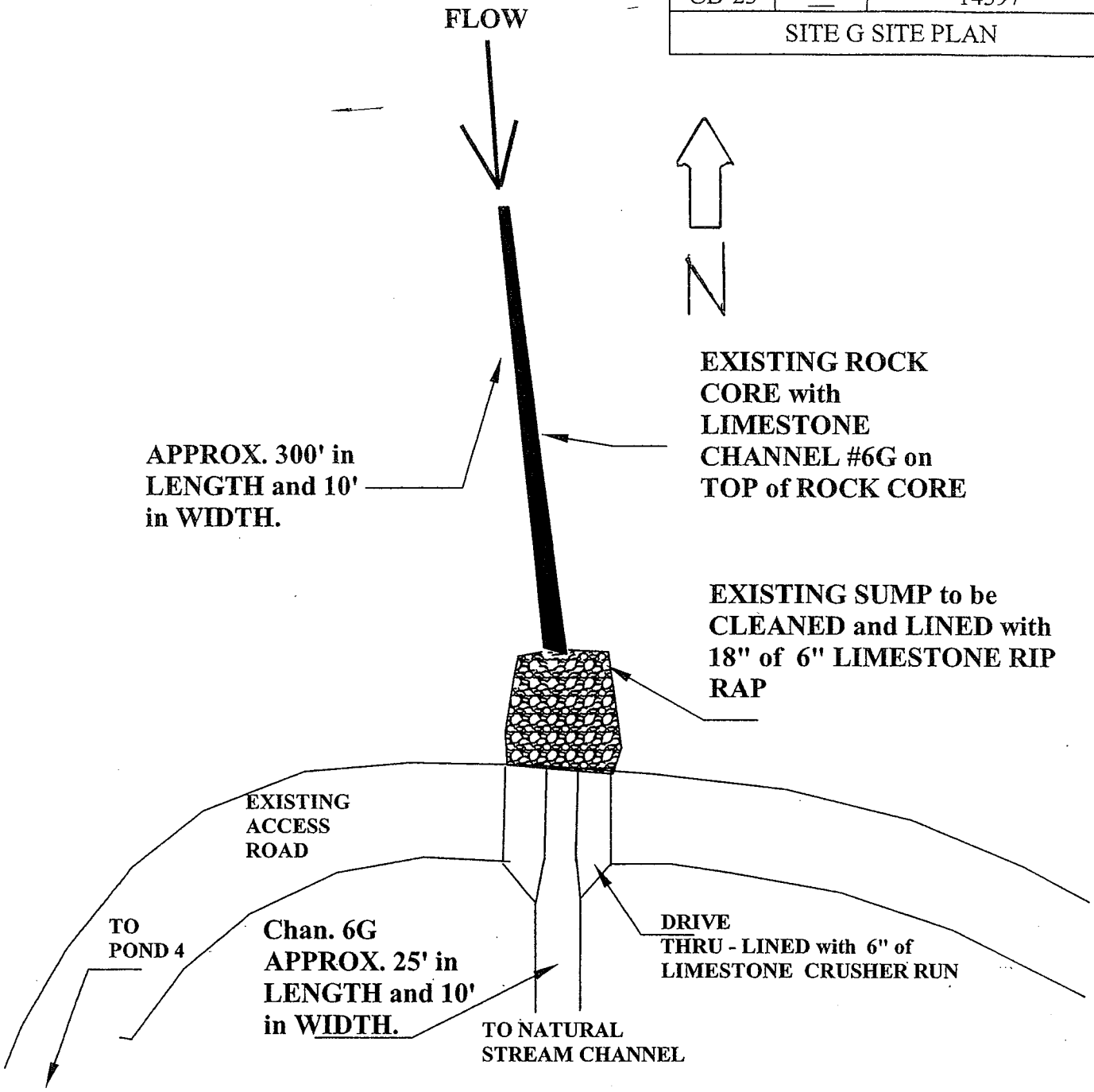

NOTE: EXISTING CHANNEL on TOP of ROCK CORE WILL BE LINED with 18" of 6" to 12" LIMESTONE RIP RAP and CHOKED DOWN with 1 and 1/2" LIMESTONE CRUSHER RUN. ROAD will be EXCAVATED DOWN TO EXISTING CULVERT and WILL BE FILLED with STANDARD LIMESTONE RIP RAP to CREATE a DRIVE THRU.

BUYER CB-23	REQ. or P.O. No. DEP 14397
CHAN 6G / SUMP PROFILE	

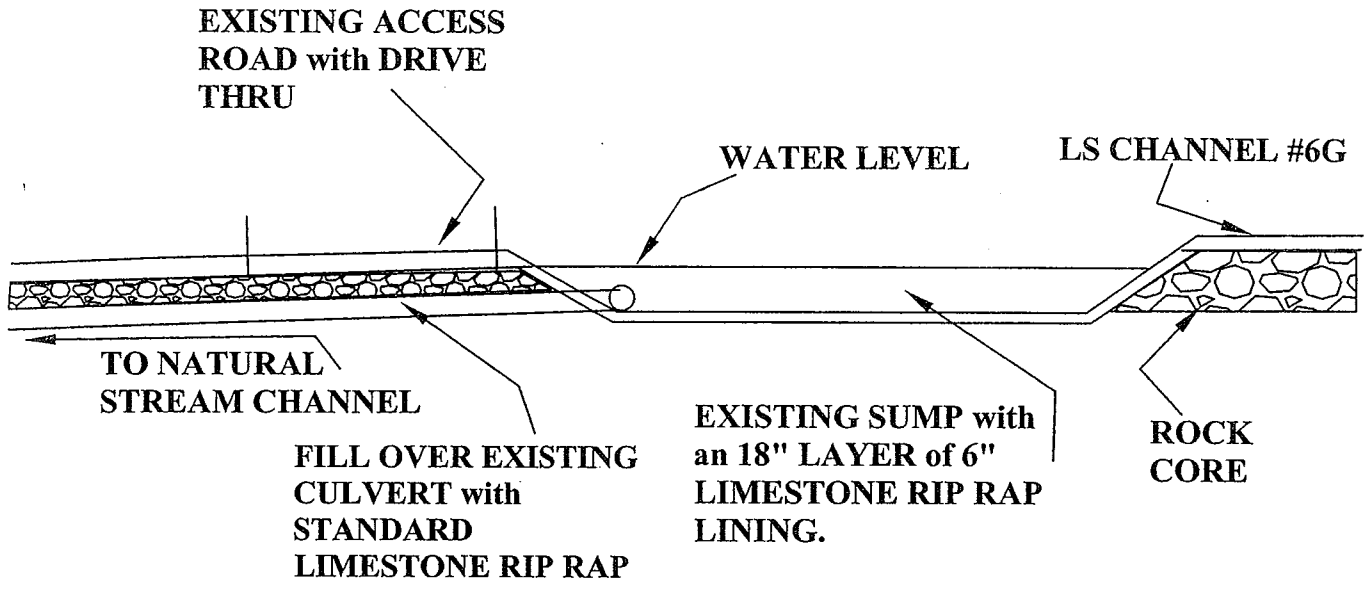

BUYER CB-23	REQ. or P.O. No. DEP 14397
----------------	-------------------------------

LS CHAN 6G/ LS FILL DRIVE THRU

**CHANNEL #6G
DRIVE THRU**

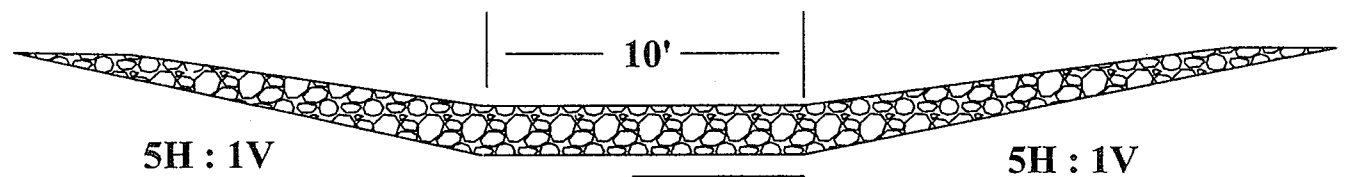

**NOTE: DEPTH
VARIES to EXISTING
CULVERT**

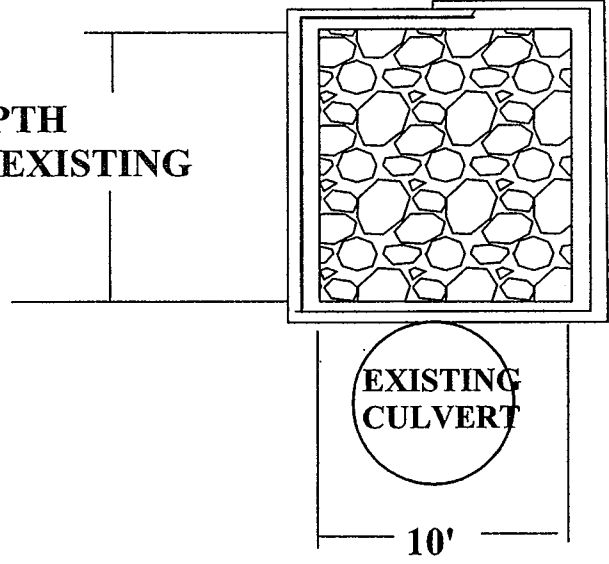

**STANDARD LS RIP
RAP WRAPPED 360
with NONWOVEN
FILTER FABRIC**

**NOTE: CHANNEL will
be CONSTRUCTED of
3" to 6" LIMESTONE
RIP RAP 18" THICK**



BUYER CB-23	REQ. or P.O. No. DEP 14397
LS CHANNEL 6G ROCK CORE	

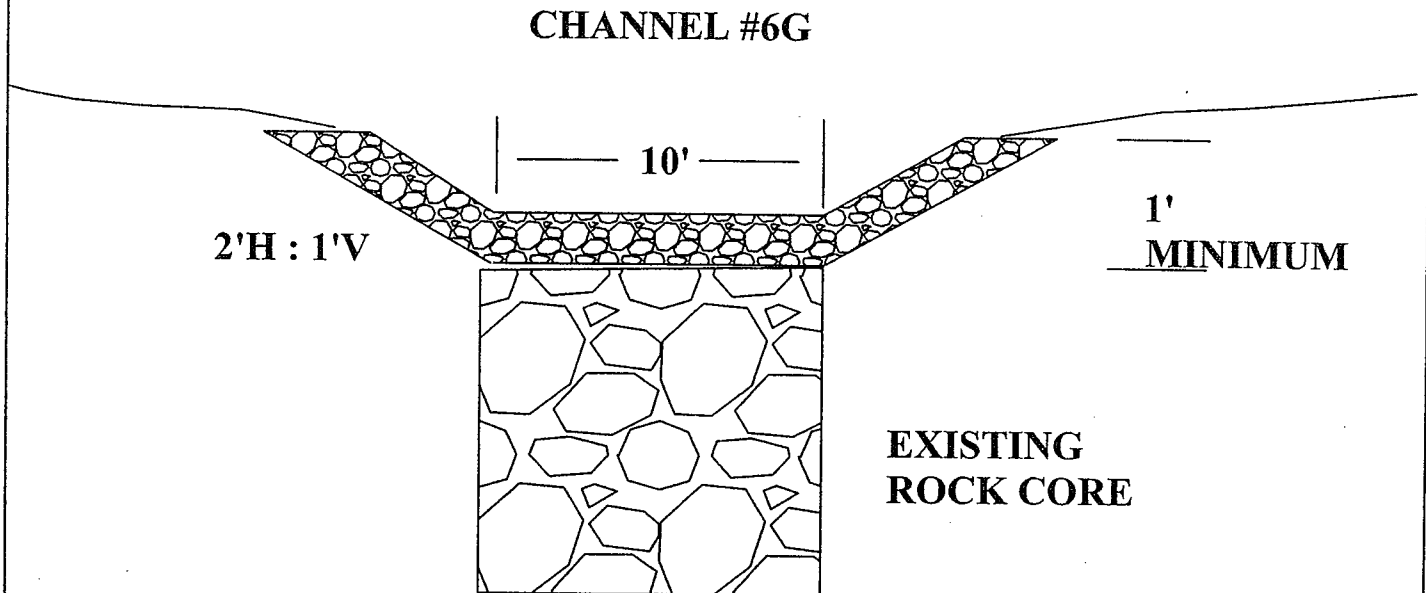

**NOTE: CHANNEL will
be CONSTRUCTED of
6" to 12" LIMESTONE
RIP RAP 18" THICK
CHOKED DOWN with
1 and 1/2" LIMESTONE
CRUSHER RUN.
CHANNEL DEPTH
will VARY**

BUYER
CB-23

REQ. or P.O. No. DEP
14397

SITE H SITE PLAN



EXISTING
ACCESS ROAD

4' x 4' SANDSTONE
UNDERDRAIN

FLOW

ROAD DITCH

LIMESTONE FILL AREA

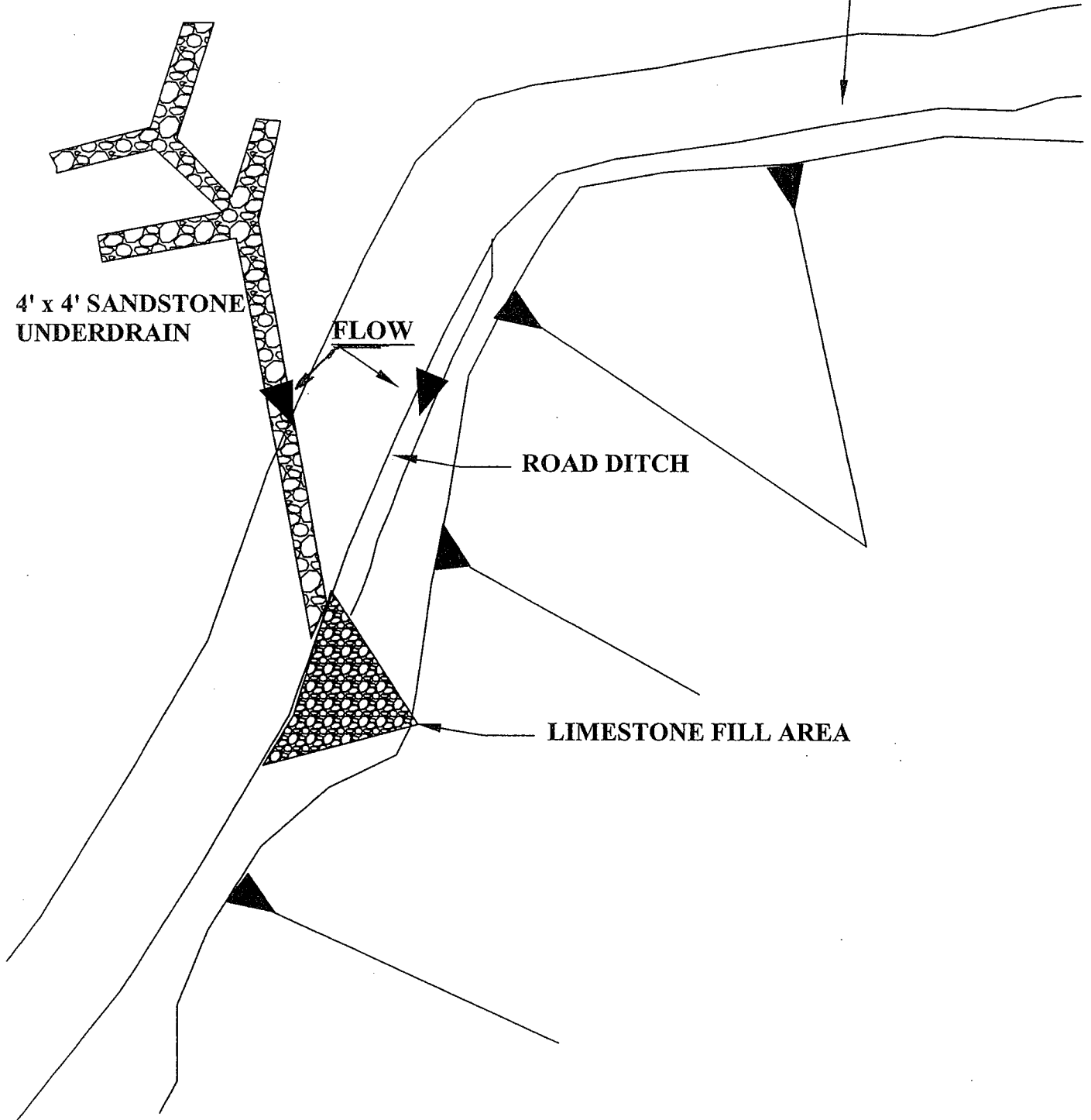

BUYER
CB-23

Q. or P.O. No. DEP
14397

LS FILL TOP VIEW SITE H

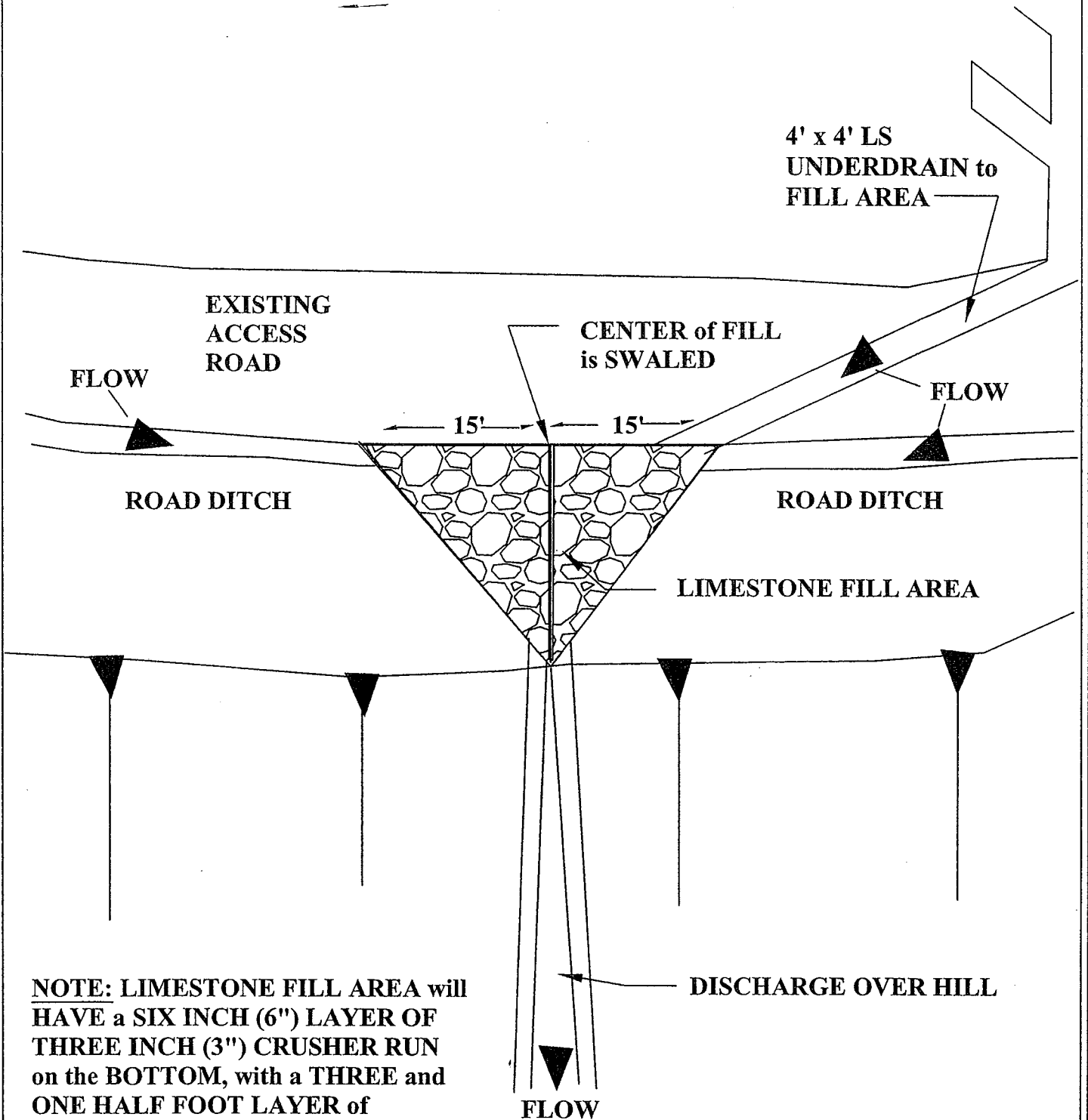

NOTE: LIMESTONE FILL AREA will HAVE a SIX INCH (6") LAYER OF THREE INCH (3") CRUSHER RUN on the BOTTOM, with a THREE and ONE HALF FOOT LAYER of STANDARD LIMESTONE RIP RAP COVERING. THE CENTER OF THE FILL AREA will be SWALED TO FACILITATE HEAVY RAIN RUNOFF.

DISCHARGE OVER HILL

FLOW

BUYER CB-23	REQ. or P.O. No. DEP 14397
WET MINE SEAL TYPICAL	

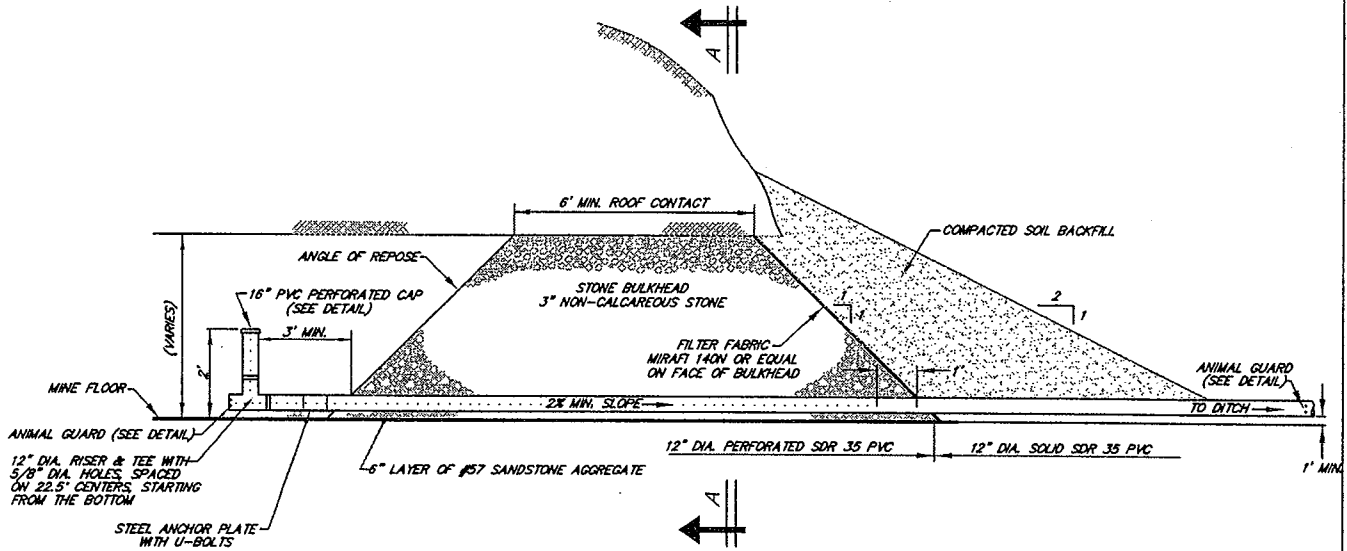

**WET MINE SEAL
TYPICAL SECTION**

N.T.S.

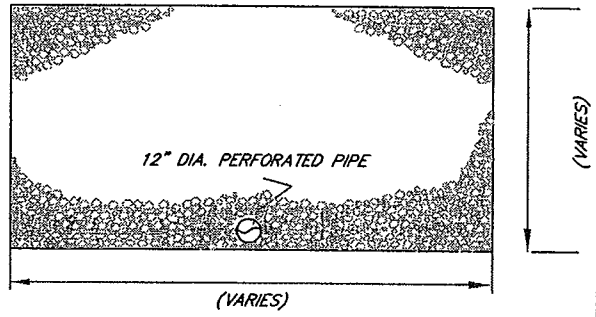
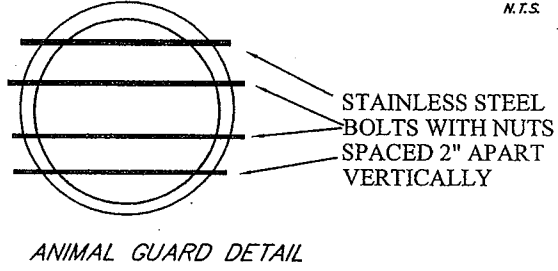

**SECTION A-A
STONE BULKHEAD
WET MINE SEAL**

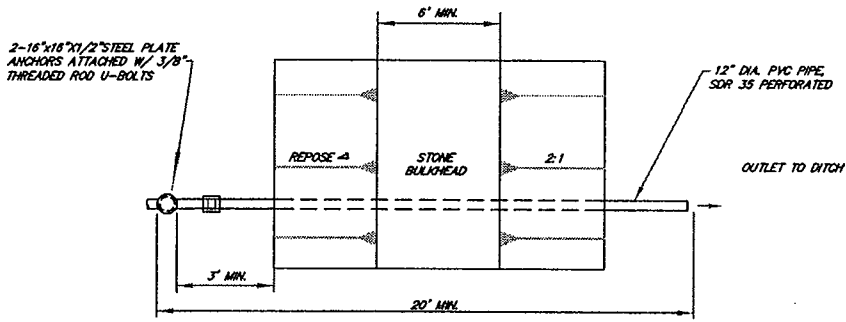

**PLAN
MINE SEAL DETAIL**

N.T.S.

plot @ 1"=40'

BUYER CB-23	REQ. or P.O. No. DEP 14397
LS FILL TOP VIEW TYPICAL	

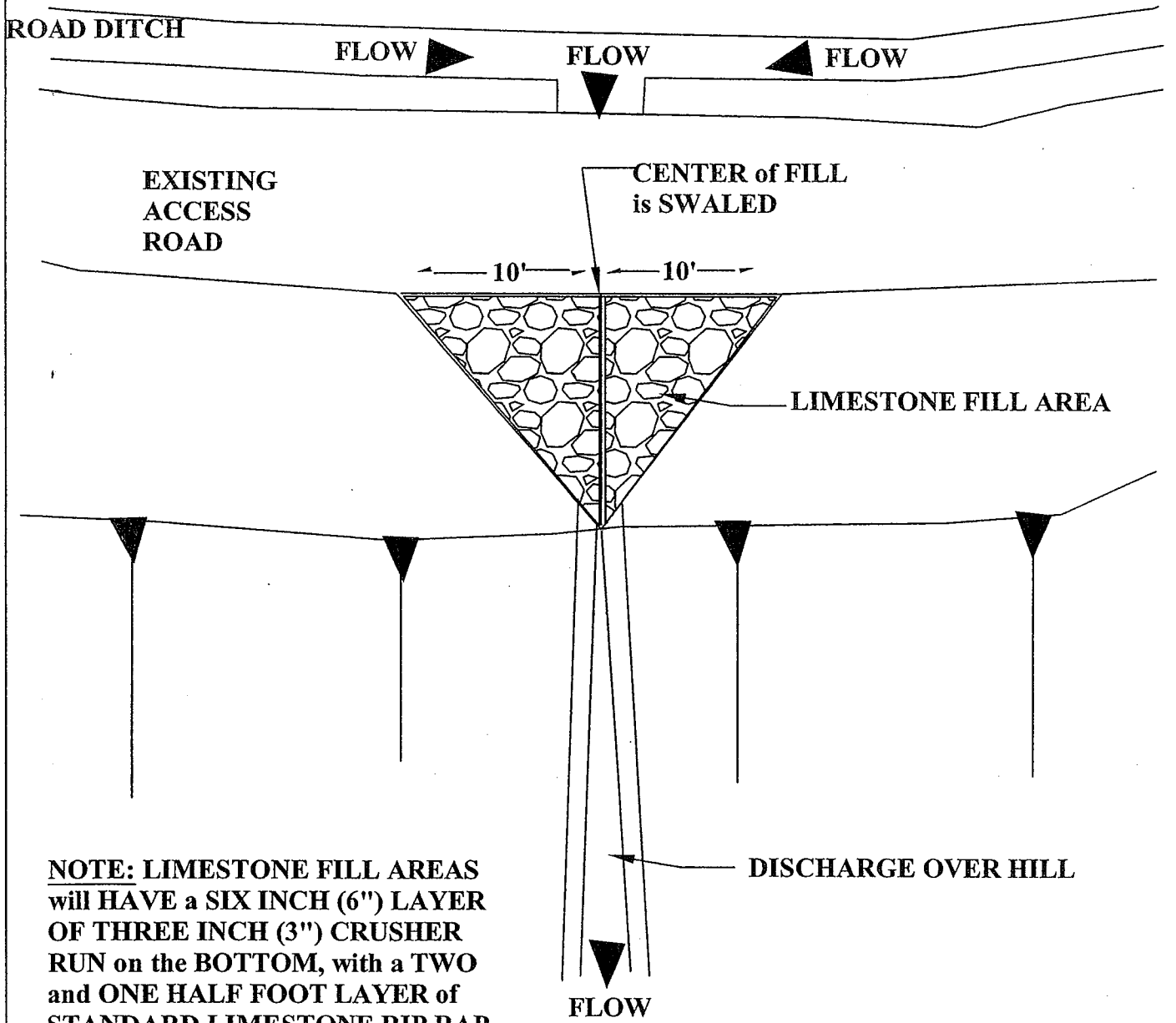

NOTE: LIMESTONE FILL AREAS will HAVE a SIX INCH (6") LAYER OF THREE INCH (3") CRUSHER RUN on the BOTTOM, with a TWO and ONE HALF FOOT LAYER of STANDARD LIMESTONE RIP RAP COVERING. THE CENTER OF THE FILL AREA will be SWALED TO FACILITATE HEAVY RAIN RUNOFF.

DISCHARGE OVER HILL

FLOW

BUYER	REQ. or P.O. No. DEP
CB-23	14397

LIMESTONE FILL CROSS SECTION

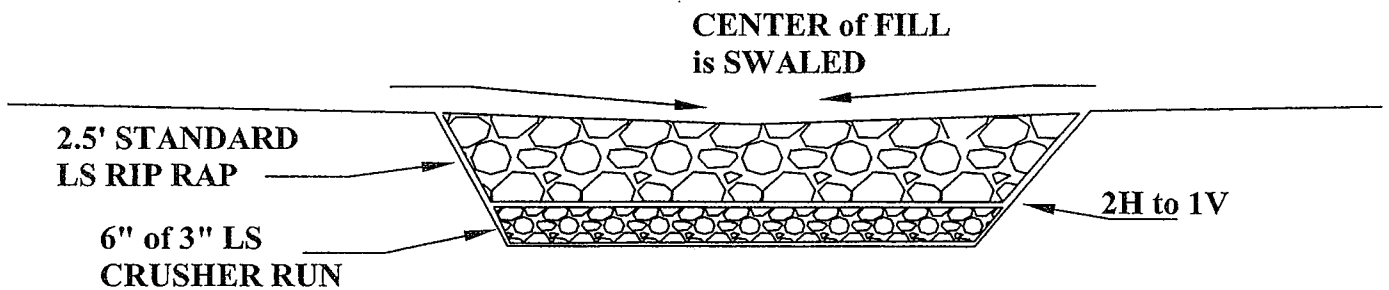

NOTE: LIMESTONE FILL AREAS
will HAVE a SIX INCH (6") LAYER
OF THREE INCH (3") CRUSHER
RUN on the BOTTOM, with a TWO
and ONE HALF FOOT LAYER of
STANDARD LIMESTONE RIP RAP
COVERING. THE CENTER OF THE
FILL AREA will be SWALED TO
FACILITATE HEAVY RAIN
RUNOFF.

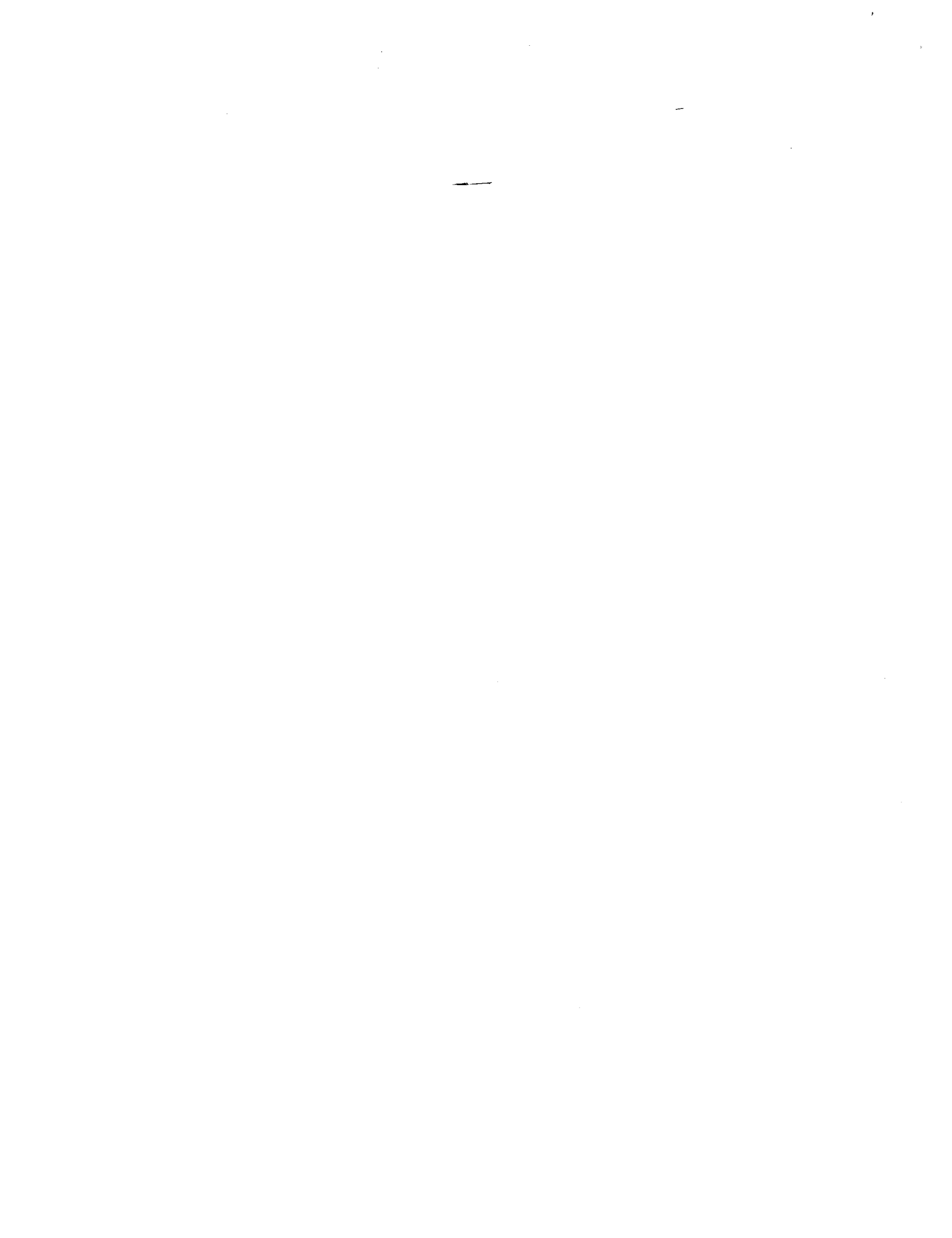

BUYER CB-23	REQ. or P.O. No. DEP 14397
TRAPEZOIDAL CHANNEL TYPICAL	

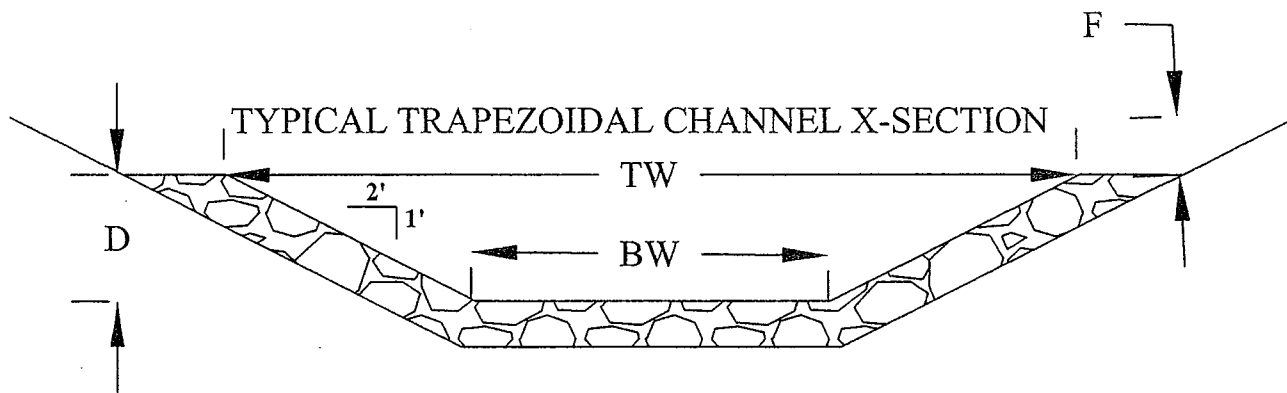

Channel #	Depth (D)	Bottom Width (BW)	Free Board	Length	Lining
Channel #1A	2	10	1 Foot	300'	Standard Limestone Rip Rap Choked with 1 1/2" LS Crusher Run
Channel #2C	2	10	1 Foot	300'	Standard Limestone Rip Rap Choked with 1 1/2" LS Crusher Run
Channel #3D	2	10	1 Foot	@350'	Standard Limestone Rip Rap Choked with 1 1/2" LS Crusher Run
Channel #4E	2	10	1 Foot	@1400'	Standard Limestone Rip Rap Choked with 1 1/2" LS Crusher Run
Channel #5F	2	10	1 Foot	100'	Standard Limestone Rip Rap Choked with 1 1/2" LS Crusher Run
Channel #6G	2	10	1 Foot	325'	Standard Limestone Rip Rap Choked with 1 1/2" LS Crusher Run
Channel #7	2	10	1 Foot	250'	Standard Limestone Rip Rap Choked with 1 1/2" LS Crusher Run

NOTE: ALL CHANNELS WILL HAVE 2H to 1V SIDE SLOPES and ONE (1) FOOT OF FREEBOARD (F). ALL MEASUREMENTS ARE IN FEET. ROCK BLANKET SHALL BE A MINIMUM OF EIGHTEEN INCHES (18") THICK THROUGHOUT. ALL GROUTED RIP RAP CHANNELS SHALL HAVE 100% GROUT PENETRATION IN ALL VOIDS.



BUYER CB-23	REQ. or P.O. No. DEP 14397
V-DITCH TYPICAL ATTACHMENT	

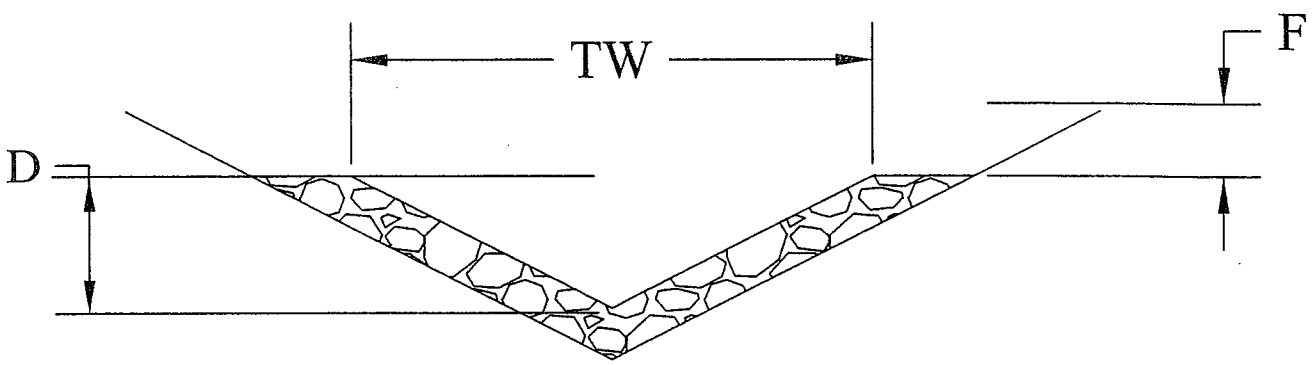

TYPICAL V-DITCH X-SECTION				
Ditch Number*	Depth (D)	Freeboard	Length (L)	Lining
V-Ditch #1B	2 Foot	1 Foot	150'	Grouted Rip Rap 100% Void Penetration
V-Ditch #1B	2 Foot	1 Foot	250'	18" Standard Limestone RipRap Choked with 1 1/2" LS Crusher Run

*** = SEE SITE B PLAN VIEW for LOCATION of DITCH SECTIONS**

NOTE: (1) FT. FREEBOARD (F) FOR ALL DITCHES. DITCH SIDES WILL HAVE 2H to 1V SLOPES. THICKNESS OF ROCK WILL BE A MINIMUM OF 18".

BUYER
CB-23

REQ. or P.O. No.
DEP 14397

SITE A ACCESS ROAD

SITE A ACCESS ROAD

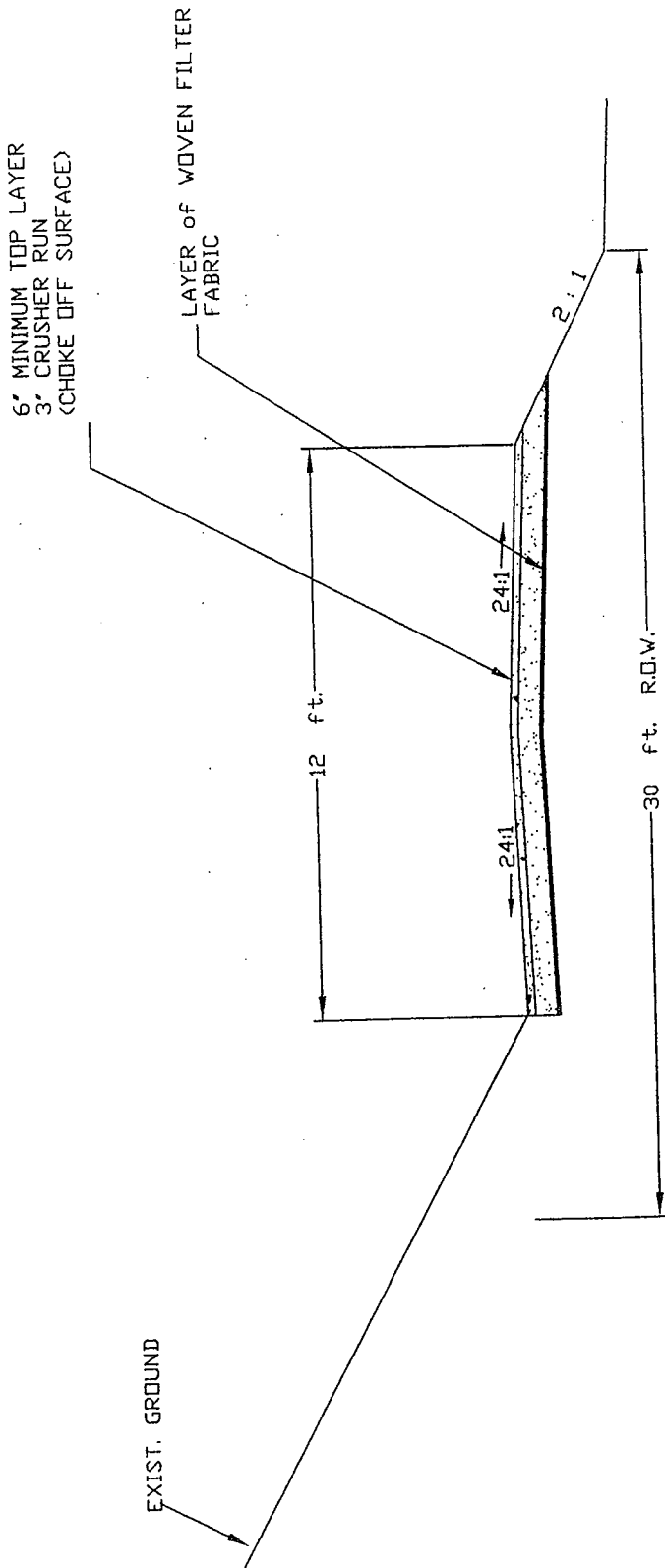

TYPICAL SECTION

NOTES:
 THE ROAD SHALL BE GRADED, SHAPED, AND ROCKED AS NECESSARY TO MEET THESE SPECIFICATIONS.
 ANY TREES OR BRUSH WITHIN THE 30 FEET R.O.W. OF THE ROAD SHALL BE REMOVED.
 ANY OVERHANGING TREE LIMBS IN THE R.O.W. AT A HEIGHT OF 15 FEET OR LESS SHALL BE REMOVED.

BUYER
CB-23

REQ. or P.O. No.
DEP 14397

SITE C ACCESS ROAD

SITE C ACCESS ROAD

6' MINIMUM TOP LAYER
3' CRUSHER RUN
(CHOKE OFF SURFACE)

LAYER of WOVEN FILTER
FABRIC

EXIST. GROUND

12 ft.

24:1

24:1

2:1

30 ft. R.O.W.

TYPICAL SECTION

- NOTES:
- THE ROAD SHALL BE GRADED, SHAPED, AND ROCKED AS NECESSARY TO MEET THESE SPECIFICATIONS.
 - ANY TREES OR BRUSH WITHIN THE 30 FEET R.O.W. OF THE ROAD SHALL BE REMOVED.
 - ANY OVERHANGING TREE LIMBS IN THE R.O.W. AT A HEIGHT OF 15 FEET OR LESS SHALL BE REMOVED.



BUYER
CB-23

REQ. or P.O. No.
DEP 14397

SITE E ACCESS ROAD

SITE E ACCESS ROAD

6" MINIMUM TOP LAYER
3" CRUSHER RUN
(CHOKE OFF SURFACE)

LAYER of WOVEN FILTER
FABRIC

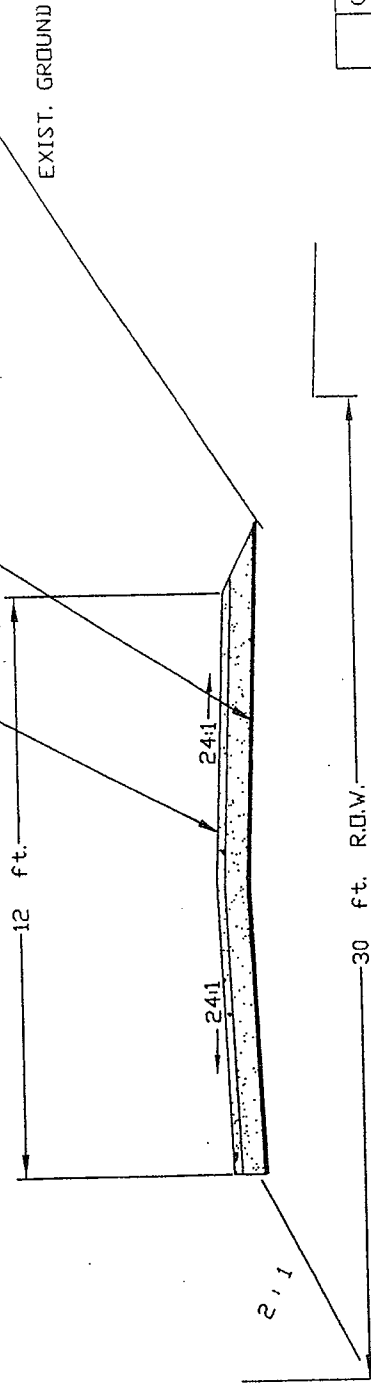

TYPICAL SECTION

- NOTES:
- THE ROAD SHALL BE GRADED, SHAPED, AND ROCKED AS NECESSARY TO MEET THESE SPECIFICATIONS.
 - ANY TREES OR BRUSH WITHIN THE 30 FEET R.O.W. OF THE ROAD SHALL BE REMOVED.
 - ANY OVERHANGING TREE LIMBS IN THE R.O.W. AT A HEIGHT OF 15 FEET OR LESS SHALL BE REMOVED.

BUYER
CB-23

REQ. or P.D. No.
DEP 14397

BENCH ACCESS ROAD
REWORK TYPICAL

BENCH ACCESS ROAD REWORK

6' MINIMUM TOP LAYER
3" CRUSHER RUN
(CHOKE OFF SURFACE)

LAYER of WOVEN FILTER
FABRIC

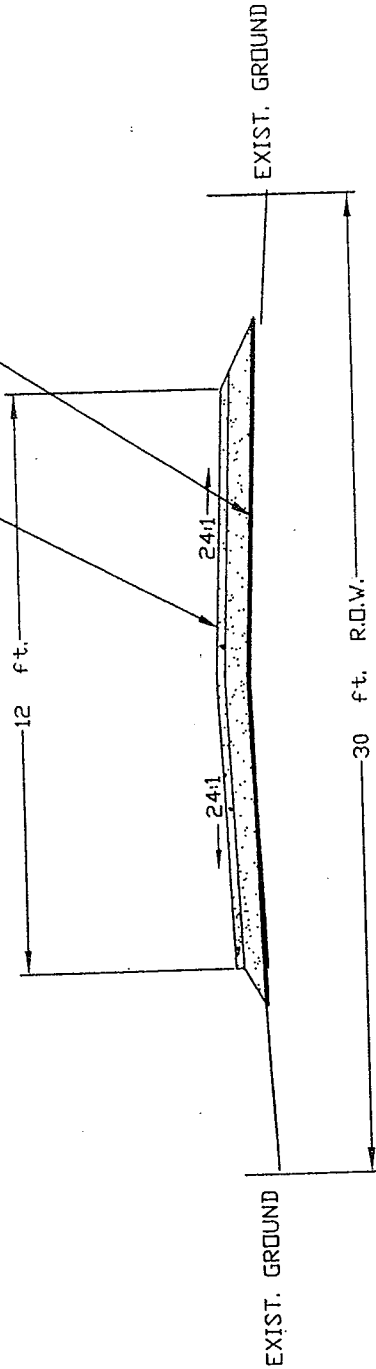

TYPICAL SECTION

- NOTES:
- THE ROAD SHALL BE REGRADED, SHAPED, AND ROCKED AS NECESSARY TO MEET THESE SPECIFICATIONS.
 - ANY TREES OR BRUSH WITHIN THE 30 FEET R.O.W. OF THE ROAD SHALL BE REMOVED.
 - ANY OVERHANGING TREE LIMBS IN THE R.O.W. AT A HEIGHT OF 15 FEET OR LESS SHALL BE REMOVED.

PRINCESS SUSAN COAL
S-6-85

6" HANCOR Sur-lok PERFORATED PIPE

FLOW

4' x 4' UNDER DRAIN

SIDE VIEW

NOT TO SCALE

WRAP 360* WITH FILTER FABRIC (NONWOVEN)
WITH 1 FOOT OVERLAP

3' TO 6' STONE
NON-CALCAREOUS
(R-3 SIZE)

6" PERF.
HANCOR PIPE

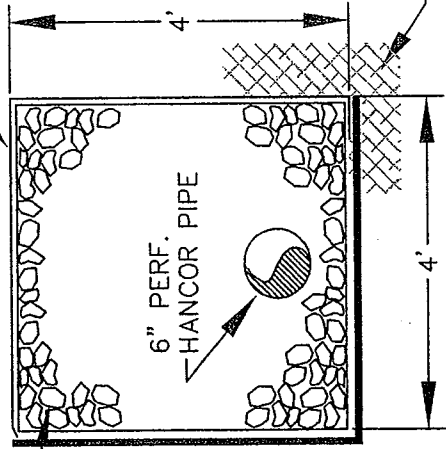

TO BE INSTALLED ON COMPETENT MATERIAL
AS APPROVED BY THE ON-SITE DEP
INSPECTOR.

END VIEW

BUYER
CB-23

REQ. or P.O. No. 68
DEP 14397

SITES B and H UNDER DRAIN
TYPICAL

BUYER		REQ. or P.O. No. DEP
CB-23		14397

DRIVE THRU TYPICAL



**12" TO 18" STANDARD SIZE RIP RAP
CHOKED DOWN WITH CRUSHER RUN**

NOTE: ENTRANCE AND EXIT THROUGH V-DITCH 1 ARE TO HAVE A 1' TO 5' SIDE SLOPE ON CHANNEL BANKS WHERE ACCESS ROAD INTERSECTS CHANNEL. ROAD MATERIAL IN CROSSINGS IS TO BE STANDARD SIZE LIMESTONE RIP RAP 12" TO 18" DEEP CHOKED DOWN WITH LIMESTONE CRUSHER RUN TO FILL ALL VOIDS IN RIP RAP.

BUYER CB-23	REQ. OR PO NO DEP 14397	70
SPENDING UNIT WEST VIRGINIA DEPARTMENT OF ENVIRONMENTAL PROTECTION / OFFICE OF SPECIAL RECLAMATION		

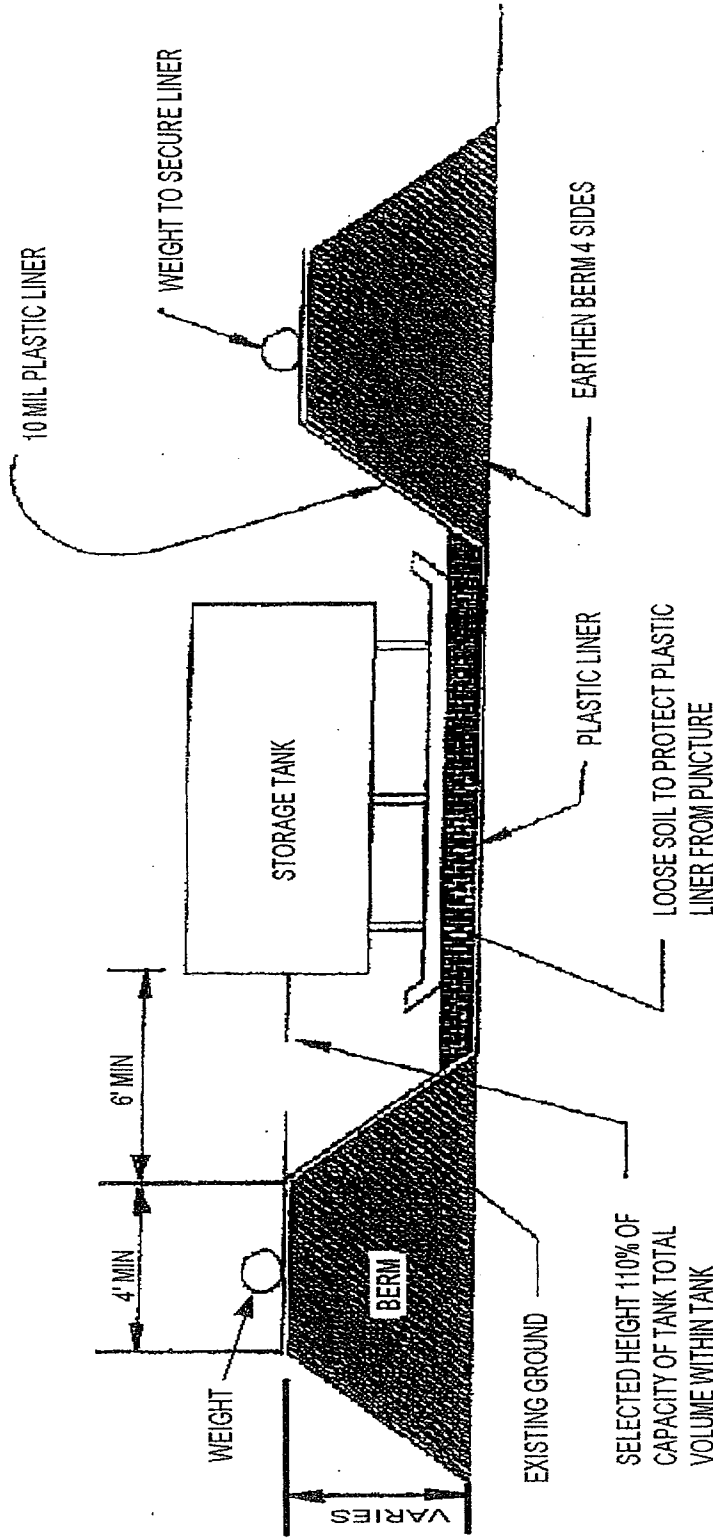

Note: A 2" water removal drain shall be located at the lowest point in the bottom of the containment volume. It shall connect to a normally closed gate-valve outside the dike. The gate-valve is manually operated and protected from unauthorized operation. Rainwater contained within this dike shall be examined prior to release to ensure that harmful quantities of fuels and lubricants are not discharged.

Alternate methods of water removal will be considered for approval.

SPECIAL RECLAMATION	
SPILL CONTAINMENT	
SCALE: N/A	DRAWN BY:
DATE:	PROJECT NO.:

SELECTED HEIGHT 110% OF
CAPACITY OF TANK TOTAL
VOLUME WITHIN TANK



State of West Virginia
 Department of Administration
 Purchasing Division
 2019 Washington Street East
 Post Office Box 50130
 Charleston, WV 25305-0130

Request for Quotation

RFQ NUMBER
DEP14397

PAGE
1

ADDRESS CORRESPONDENCE TO ATTENTION OF:
**CHUCK BOWMAN
 304-558-2157**

***709060417 304-984-1115**
CARPENTER RECLAMATION INC
PO BOX 13015
SISSONVILLE WV 25360-0015

ENVIRONMENTAL PROTECTION
DEPT. OF
OFFICE OF SPECIAL RECLAMATION
601 57TH STREET SE
CHARLESTON, WV
25304 304-926-0499

DATE PRINTED	TERMS OF SALE	SHIP VIA	F.O.B	FREIGHT TERMS
07/19/2010				

BID OPENING DATE: **07/29/2010** BID OPENING TIME **01:30PM**

LINE	QUANTITY	UOP	CAT. NO.	ITEM NUMBER	UNIT PRICE	AMOUNT
				***** ADDENDUM NO. 2 *****		
				ADDENDUM ISSUED FOR THE PRINCESS SUSAN COAL CO. PROJECT TO DISTRIBUTE THE PRE-BID SIGN-IN SHEETS AND THE Q/A RESULTING FROM THE MANDATORY 06/16/10 PRE-BID MEETING.		
				BID OPENING DATE & TIME REMAIN 07/29/10 AT 1:30 PM.		
				***** NO OTHER CHANGES *****		
0001	1	JB		962-73		
				RECLAMATION: RESTORATION OF LAND		
				***** THIS IS THE END OF RFQ DEP14397 ***** TOTAL: \$ <u>661,101.00</u>		

SEE REVERSE SIDE FOR TERMS AND CONDITIONS

SIGNATURE <i>Kelley Carpenter</i>	TELEPHONE 304 984 1115	DATE 7-29-10
TITLE <i>President</i>	FEIN 55-0693493	ADDRESS CHANGES TO BE NOTED ABOVE

WHEN RESPONDING TO RFQ, INSERT NAME AND ADDRESS IN SPACE ABOVE LABELED 'VENDOR'

ADDENDUM NO. 2

PRE-BID FOR PRINCESS SUSAN, S-6-85**JUNE 16, 2010****QUESTIONS AND ANSWERS:**

1. (site A) Is that stone (300' section of limestone rip-rap channel) added in on the access road stone or is it a separate item?

Answer: It is a separate bid item (20.1)

2. (site B) If we hit solid rock here (access road), do we delete the rock rip-rap (as outlined in the scope of work)?

Answer: Yes. If you hit solid rock, you do not have to place rock rip-rap.

3. (site G) Are you just reshaping the rock core?

Answer: Yes, reshaping the top and line with 18 inches of 6"-12" stone and choked down with crusher run.

4. (access road) Is there pipe to be installed in the road?

Answer: No pipe will be installed in access road.

5. Is the road (access road) going back down to be resurfaced?

Answer: No, just on top.

6. Down this way (below junction) just gets regraded and not resurfaced?

Answer: The road gets resurfaced from the intersection, all the way around until you reach 10,500 feet. The rest will be maintained.

MANDATORY PRE-BID SIGN-IN ATTENDANCE SHEET

RFQ # : DEP 14397
Project: Princess Susan C.G. 5-6-85

Bid Date: 7-14-10
Pre-Bid Date: 6-16-10

Name : LES BYRN
Company: ASPEN CORPORATION
Address: 2400 RITTER DR.
DANIELS WV 25832
Phone #: 304-763-4573
Fax #: 304-763-4591
Email : lholer@aspengolf.com

Name : GEORGE FRESHOUR
Company: EAGLE EXCAVATION, INC.
Address: P.O. Box 218
KENNA WV
25248
Phone# : (304) 372-4378
Fax # : (304) 372-4378
Email : NONE

Name : W R Hoock
Company: Pineville Paving
Address: PO Box 1290
Pineville WV 24874
Phone #: 304 732 8303
Fax # : 304 732 2855
Email :

Name : Mick Jones
Company: Bement Const
Address: PO box 10 Procius WV.
25164
Phone# : 304-548-7004
Fax # : 548-7133
Email : bementconst@yahoo.com

Name : GARY LONG
Company: McCourt & Son Const.
Address: 2790 Centralia Rd
Sutton WV 26601
Phone #: 304 765-5288
Fax # : 304 765-5293
Email :

Name : J.P. SPENCER
Company: RONIE SPENCER, INC
Address: HC 74, Box 201
STRANGE CREEK, WV
25063
Phone# : 304-364-8626
Fax # : 364-8376
Email : RHS20 Hughes.NET

Name : Robert Barnes
Company: BARNES EXC INC.
Address: P.O. Box 13384
SISSONVILLE
WV. 25360
Phone #: 304-984-1725
Fax # : 304-984-0074
Email : BARNES_EXC@AOL.COM

Name : DAVID H. BOWMAN
Company: GREEN MOUNTAIN CO
Address: 611 50th STREET
CHAS WV 25304
Phone# : 304 925 0255
Fax # : 925 9230
Email : Jody Maye@DL.com

MANDATORY PRE-BID SIGN-IN ATTENDANCE SHEET

RFQ # : DEP 14397
Project: Princess Susan G.C.G. 5-6-85

Bid Date: 7-14-10
Pre-Bid Date: 6-16-10

Name : BRAD WISEMAN
Company: WISEMAN EXCAVATING
Address: RT 1 BOX 190 LIBERTY WV 25124

Name : Jay R Wardwell
Company: Eastern Arrow
Address: Charleston WV.

Phone #: 304-586-3736
Fax #: 304-586-3789
Email : _____

Phone#: 304 414-0255
Fax #: 304 414-0256
Email : _____

Name : Kelley Carpenter
Company: Carpenter Reclamation
Address: P.O. Box 13015 Sissonville WV 25360

Name : _____
Company: _____
Address: _____

Phone #: 304-984-1115
Fax #: 304-984-2770
Email : RCARPEN103@AOL.COM

Phone#: _____
Fax #: _____
Email : _____

Name : Kelly Dennison
Company: Breakaway Inc
Address: Sutton WVA 26601 1750 Old Turnpike Rd.

Name : _____
Company: _____
Address: _____

Phone #: 304-765-5317
Fax #: 304-765-5317
Email : _____

Phone#: _____
Fax #: _____
Email : _____

Name : Jim Butcher
Company: Select EXCAVATING Ser LLC
Address: JANE LEW, WV 26378 P.O. Box 581

Name : _____
Company: _____
Address: _____

Phone #: 304-613-9194
Fax #: 304-269-5455
Email : Select EXCAVATING eVidInc.com

Phone#: _____
Fax #: _____
Email : _____

AVS OFT Report - 4/5/2010 12:56:36 PM

All OFT's where the selected entity is listed as an entity or related entity

Entity Selected (140618) Carpenter Reclamation Inc

Parent Entity	Description	Related Entity	% Ownership	Begin Date	End Date
(140618) Carpenter Reclamation Inc	President	(140616) Kelley Carpenter		10/1/1989	
(140618) Carpenter Reclamation Inc	Shareholder	(140616) Kelley Carpenter	50%	10/1/1989	
(140618) Carpenter Reclamation Inc	Shareholder	(140617) Mary Carpenter	50%	10/1/1989	
(140618) Carpenter Reclamation Inc	Vice President	(140617) Mary Carpenter		10/1/1989	

7-29-10

Current Information

K. Carpenter



State of West Virginia
 Department of Administration
 Purchasing Division
 2019 Washington Street East
 Post Office Box 50130
 Charleston, WV 25305-0130

Request for Quotation

RFQ NUMBER
 DEP14397

PAGE
 1

ADDRESS CORRESPONDENCE TO ATTENTION OF
 CHUCK BOWMAN
 304-558-2157

VENDOR

*709060417 304-984-1115
 CARPENTER RECLAMATION INC
 PO BOX 13015

 SISSONVILLE WV 25360-0015

SHIP TO

ENVIRONMENTAL PROTECTION
 DEPT. OF
 OFFICE OF SPECIAL RECLAMATION
 601 57TH STREET SE
 CHARLESTON, WV
 25304 304-926-0499

DATE PRINTED	TERMS OF SALE	SHIP VIA	F.O.B.	FREIGHT TERMS
07/12/2010				

BID OPENING DATE: 07/29/2010 BID OPENING TIME 01:30PM

LINE	QUANTITY	UOP	CAT NO	ITEM NUMBER	UNIT PRICE	AMOUNT
0001	1	JB		962-73		
ADDENDUM NO. 1 ***** ADDENDUM ISSUED FOR THE PRINCESS COAL CO PROJECT NEAR CEDAR GROVE, KANAWHA CO, TO DELAY THE BID OPENING DATE WHILE WAITING FOR THE INFORMATIONAL ADDENDUM RESULTING FROM THE 06/16/10 MANDATORY PRE-BID MEETING. ADDENDUM NO.2 WILL BE ISSUED SHORTLY. BID OPENING DATE & TIME EXTENDED FROM 07/14/10 TO 07/29/10 AT 1:30 PM. ***** NO OTHER CHANGES *****						
***** THIS IS THE END OF RFQ DEP14397 ***** TOTAL:						<u>\$ 661,101.00</u>

SEE REVERSE SIDE FOR TERMS AND CONDITIONS

SIGNATURE <i>Kelley Carpenter</i>	TELEPHONE 304 984 1115	DATE 7-29-10
TITLE <i>President</i>	FEIN 55-0693493	ADDRESS CHANGES TO BE NOTED ABOVE

WHEN RESPONDING TO RFQ, INSERT NAME AND ADDRESS IN SPACE ABOVE LABELED 'VENDOR'

BID BOND

KNOW ALL MEN BY THESE PRESENTS, That we, the undersigned, See Attached
_____ of _____, _____, as Principal, and _____
_____ of _____, _____, a corporation organized and existing under the laws of the State of _____
_____ with its principal office in the City of _____, as Surety, are held and firmly bound unto the State
of West Virginia, as Obligee, in the penal sum of _____ (\$ _____) for the payment of which,
well and truly to be made, we jointly and severally bind ourselves, our heirs, administrators, executors, successors and assigns.

The Condition of the above obligation is such that whereas the Principal has submitted to the Purchasing Section of the
Department of Administration a certain bid or proposal, attached hereto and made a part hereof, to enter into a contract in writing for

NOW THEREFORE,

- (a) If said bid shall be rejected, or
- (b) If said bid shall be accepted and the Principal shall enter into a contract in accordance with the bid or proposal attached
hereto and shall furnish any other bonds and insurance required by the bid or proposal, and shall in all other respects perform the
agreement created by the acceptance of said bid, then this obligation shall be null and void, otherwise this obligation shall remain in full
force and effect. It is expressly understood and agreed that the liability of the Surety for any and all claims hereunder shall, in no event,
exceed the penal amount of this obligation as herein stated.

The Surety, for the value received, hereby stipulates and agrees that the obligations of said Surety and its bond shall be in no
way impaired or affected by any extension of the time within which the Obligee may accept such bid, and said Surety does hereby
waive notice of any such extension.

IN WITNESS WHEREOF, Principal and Surety have hereunto set their hands and seals, and such of them as are corporations
have caused their corporate seals to be affixed hereunto and these presents to be signed by their proper officers, this
_____ day of _____, 20_____.

Principal Corporate Seal

(Name of Principal)

By _____
(Must be President or
Vice President)

(Title)

Surety Corporate Seal

(Name of Surety)

Attorney-in-Fact

**IMPORTANT - Surety executing bonds must be licensed in West Virginia to transact surety insurance. Raised corporate seals
must be affixed, a power of attorney must be attached.**

AGENCY _____ (A)
RFQ/RFP# _____ (B)

- (A) WV State Agency
(Stated on Page 1 "Spending Unit")
Request for Quotation Number (upper right corner of page #1)
- (C) Your Company Name
- (D) City, Location of your Company
- (E) State, Location of your Company
- (F) Surety Corporate Name
- (G) City, Location of Surety
- (H) State, Location of Surety
- (I) State of Surety Incorporation
- (J) City of Surety Incorporation
- (K) Minimum amount of acceptable bid bond is 5% of total bid. You may state "5% of bid" or a specific amount on this line in words.
- (L) Amount of bond in figures
- (M) Brief Description of scope of work
- (N) Day of the month
- (O) Month
- (P) Year
- (Q) Name of Corporation
- (R) Raised Corporate Seal of Principal
- (S) Signature of President or Vice President
- (T) Title of person signing
- (U) Raised Corporate Seal of Surety
- (V) Corporate Name of Surety
- (W) Signature of Attorney in Fact of the Surety

NOTE: Dated, Power of Attorney with Raised Surety Seal must accompany this bid bond.

Bid Bond

KNOW ALL MEN BY THESE PRESENTS, That we, the undersigned, _____ (C) of _____ (D), _____ (E), as Principal, and _____ (F) of _____ (G), _____ (H), a corporation organized and existing under the laws of the State of _____ (I) with its principal office in the City of _____ (J), as Surety, are held and firmly bound unto The State of West Virginia, as Obligee, in the penal sum of _____ (K) (\$ _____ (L)) for the payment of which, well and truly to be made, we jointly and severally bind ourselves, our heirs, administrators, executors, successors and assigns.

The Condition of the above obligation is such that whereas the Principal has submitted to the Purchasing Section of the Department of Administration a certain bid or proposal, attached hereto and made a part hereof to enter into a contract in writing for _____ (M)

NOW THEREFORE.

(a) If said bid shall be rejected, or

(b) If said bid shall be accepted and the Principal shall enter into a contract in accordance with the bid or proposal attached hereto and shall furnish any other bonds and insurance required by the bid or proposal, and shall in all other respects perform the agreement created by the acceptance of said bid then this obligation shall be null and void, otherwise this obligation shall remain in full force and effect. It is expressly understood and agreed that the liability of the Surety for any and all claims hereunder shall, in no event, exceed the penal amount of this obligation as herein stated

The Surety for value received, hereby stipulates and agrees that the obligations of said Surety and its bond shall be in no way impaired or affected by any extension of time within which the Obligee may accept such bid: and said Surety does hereby waive notice of any such extension.

IN WITNESS WHEREOF, Principal and Surety have hereunto set their hands and seals, and such of them as are corporations have caused their corporate seals to be affixed hereto and these presents to be signed by their proper officers, this _____ (N) day of _____ (O), 20 _____ (P).

Principal Corporate Seal

(R)

(Name of Principal)
By _____
(Must be President or Vice President)

Title

(U)
Surety Corporate Seal

(Name of Surety)

Attorney-in-Fact

IMPORTANT – Surety executing bonds must be licensed in West Virginia to transact surety insurance. Raised Corporate Seals must be affixed and a Power of Attorney must be attached.

BID BOND

KNOW ALL MEN BY THESE PRESENTS, That we, the undersigned, Carpenter Reclamation, Inc
of PO Box 13015 Sissonville, WV 25360, as Principal, and Western Surety Company
of U.S. Steel Tower, 600 Grant Street, Suite 500, Pittsburgh, PA a corporation organized and existing under the laws of the State of South Dakota with its principal office in the City of Sioux Falls, as Surety, are held and firmly bound unto the State of West Virginia, as Obligee, in the penal sum of Five Percent (\$ 5%) for the payment of which, well and truly to be made, we jointly and severally bind ourselves, our heirs, administrators, executors, successors and assigns.

The Condition of the above obligation is such that whereas the Principal has submitted to the Purchasing Section of the Department of Administration a certain bid or proposal, attached hereto and made a part hereof, to enter into a contract in writing for DEP14397, Princess Susan Coal in Kanawha County WV, according to plans and specifications.

NOW THEREFORE,

- (a) If said bid shall be rejected, or
- (b) If said bid shall be accepted and the Principal shall enter into a contract in accordance with the bid or proposal attached hereto and shall furnish any other bonds and insurance required by the bid or proposal, and shall in all other respects perform the agreement created by the acceptance of said bid, then this obligation shall be null and void, otherwise this obligation shall remain in full force and effect. It is expressly understood and agreed that the liability of the Surety for any and all claims hereunder shall, in no event, exceed the penal amount of this obligation as herein stated.

The Surety, for the value received, hereby stipulates and agrees that the obligations of said Surety and its bond shall be in no way impaired or affected by any extension of the time within which the Obligee may accept such bid, and said Surety does hereby waive notice of any such extension.

IN WITNESS WHEREOF, Principal and Surety have hereunto set their hands and seals, and such of them as are corporations have caused their corporate seals to be affixed hereunto and these presents to be signed by their proper officers, this 28th day of June, 20 10.

Principal Corporate Seal

Carpenter Reclamation

(Name of Principal)

By Kelley Carpenter
Kelley Carpenter (Must be President or Vice President)

President

(Title)

Surety Corporate Seal

Western Surety Company

(Name of Surety)

Ross E. Johnson
Ross E. Johnson Attorney-in-Fact

IMPORTANT – Surety executing bonds must be licensed in West Virginia to transact surety insurance. Corporate seals must be affixed, and a power of attorney must be attached.

Western Surety Company

POWER OF ATTORNEY APPOINTING INDIVIDUAL ATTORNEY-IN-FACT

Know All Men By These Presents, That WESTERN SURETY COMPANY, a South Dakota corporation, is a duly organized and existing corporation having its principal office in the City of Sioux Falls, and State of South Dakota, and that it does by virtue of the signature and seal herein affixed hereby make, constitute and appoint

Ross E Johnson, Beverly A Holstine, Kathryn K Arthur, Sheila Mc Cormick, Individually

of Charleston, WV, its true and lawful Attorney(s)-in-Fact with full power and authority hereby conferred to sign, seal and execute for and on its behalf bonds, undertakings and other obligatory instruments of similar nature

- In Unlimited Amounts -

and to bind it thereby as fully and to the same extent as if such instruments were signed by a duly authorized officer of the corporation and all the acts of said Attorney, pursuant to the authority hereby given, are hereby ratified and confirmed.

This Power of Attorney is made and executed pursuant to and by authority of the By-Law printed on the reverse hereof, duly adopted, as indicated, by the shareholders of the corporation.

In Witness Whereof, WESTERN SURETY COMPANY has caused these presents to be signed by its Senior Vice President and its corporate seal to be hereto affixed on this 25th day of April, 2008.

WESTERN SURETY COMPANY



Paul T. Brufat
Paul T. Brufat, Senior Vice President

State of South Dakota }
County of Minnehaha } ss

On this 25th day of April, 2008, before me personally came Paul T. Brufat, to me known, who, being by me duly sworn, did depose and say: that he resides in the City of Sioux Falls, State of South Dakota; that he is the Senior Vice President of WESTERN SURETY COMPANY described in and which executed the above instrument; that he knows the seal of said corporation; that the seal affixed to the said instrument is such corporate seal; that it was so affixed pursuant to authority given by the Board of Directors of said corporation and that he signed his name thereto pursuant to like authority, and acknowledges same to be the act and deed of said corporation.

My commission expires
November 30, 2012



D. Krell
D. Krell, Notary Public

CERTIFICATE

I, L. Nelson, Assistant Secretary of WESTERN SURETY COMPANY do hereby certify that the Power of Attorney hereinabove set forth is still in force, and further certify that the By-Law of the corporation printed on the reverse hereof is still in force. In testimony whereof I have hereunto subscribed my name and affixed the seal of the said corporation this 28th day of June, 2010



WESTERN SURETY COMPANY

L. Nelson
L. Nelson, Assistant Secretary

Authorizing By-Law

ADOPTED BY THE SHAREHOLDERS OF WESTERN SURETY COMPANY

This Power of Attorney is made and executed pursuant to and by authority of the following By-Law duly adopted by the shareholders of the Company.

Section 7. All bonds, policies, undertakings, Powers of Attorney, or other obligations of the corporation shall be executed in the corporate name of the Company by the President, Secretary, and Assistant Secretary, Treasurer, or any Vice President, or by such other officers as the Board of Directors may authorize. The President, any Vice President, Secretary, any Assistant Secretary, or the Treasurer may appoint Attorneys in Fact or agents who shall have authority to issue bonds, policies, or undertakings in the name of the Company. The corporate seal is not necessary for the validity of any bonds, policies, undertakings, Powers of Attorney or other obligations of the corporation. The signature of any such officer and the corporate seal may be printed by facsimile.



State of West Virginia
DRUG FREE WORKPLACE CONFORMANCE AFFIDAVIT
West Virginia Code §21-1D-5

STATE OF West Virginia

COUNTY OF Kanawha, TO-WIT:

I, Kelley Carpenter, after being first duly sworn, depose and state as follows:

- 1. I am an employee of Carpenter Reclamation Inc.; and,
(Company Name)
- 2. I do hereby attest that Carpenter Reclamation Inc.
(Company Name)

maintains a valid written drug free workplace policy and that such policy is in compliance with **West Virginia Code** §21-1D-5.

The above statements are sworn to under the penalty of perjury.

Carpenter Reclamation Inc.
(Company Name)

By: Kelley Carpenter

Title: President

Date: 7-29-10

Taken, subscribed and sworn to before me this 29 day of July ND 2010.

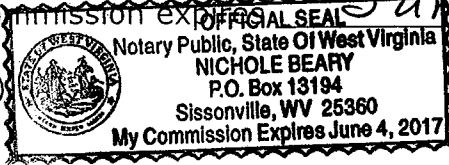
By Commission Expires June 4, 2017
(Seal)  Nichole Beary
(Notary Public)

THIS AFFIDAVIT MUST BE SUBMITTED WITH THE BID IN ORDER TO COMPLY WITH WV CODE PROVISIONS. FAILURE TO INCLUDE THE AFFIDAVIT WITH THE BID SHALL RESULT IN DISQUALIFICATION OF THE BID.

RFQ No. DEP-14397

STATE OF WEST VIRGINIA
Purchasing Division

PURCHASING AFFIDAVIT

West Virginia Code §5A-3_10a states: No contract or renewal of any contract may be awarded by the state or any of its political subdivisions to any vendor or prospective vendor when the vendor or prospective vendor or a related party to the vendor or prospective vendor is a debtor and the debt owned is an amount greater than one thousand dollars in the aggregate

DEFINITIONS:

"Debt" means any assessment, premium, penalty, fine, tax or other amount of money owed to the state or any of its political subdivision because of a judgment, fine, permit violation, license assessment, defaulted workers' compensation premium, penalty or other assessment presently delinquent or due and required to be paid to the state or any of its political subdivisions, including any interest or additional penalties accrued thereon.

"Debtor" means any individual, corporation, partnership, association, Limited Liability Company or any other form or business association owing a debt to the state or any of its political subdivisions. "Political subdivision" means any county commission; municipality; county board of education; any instrumentality established by a county or municipality; any separate corporation or instrumentality established by one or more counties or municipalities, as permitted by law; or any public body charged by law with the performance of a government function or whose jurisdiction is coextensive with one or more counties or municipalities. "Related party" means a party, whether an individual, corporation, partnership, association, Limited liability company or any other form or business association or other entity whatsoever, related to any vendor by blood, marriage, ownership or contract through which the party has a relationship of ownership or other interest consideration from performance of a vendor contract with the party receiving an amount that meets or exceeds five percent of the total contract amount.

EXCEPTION: The prohibition of this section does not apply where a vendor has contested any tax administered pursuant to chapter eleven of this code, workers' compensation premium, permit fee or environmental fee or assessment and the matter has not become final or where the vendor has entered into a payment plan or agreement and the vendor is not in default of any of the provisions of such plan or agreement.

Under penalty of Law for false swearing (*West Virginia Code §61-5-3*), it is hereby certified that the vendor affirms and acknowledges the information in this affidavit and is in compliance with the requirements as stated.

WITNESS THE FOLLOWING SIGNATURE

Vendor's Name: Carpenter Reclamation Inc. u

Authorized Signature: Kelly Carpenter Date: 7-29-10

State of West Virginia

County of Kanawha to-wit:

Taken, subscribed, and sworn to before me this 29th day of July, 2010

My Commission expires June 4, 2017

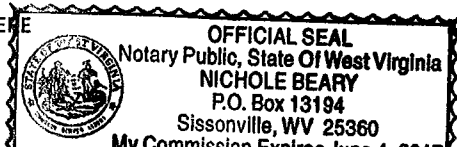
AFFIX SEAL HERE  NOTARY PUBLIC Nichole Beary