



State of West Virginia  
 Department of Administration  
 Purchasing Division  
 2019 Washington Street East  
 Post Office Box 50130  
 Charleston, WV 25305-0130

# Request for Quotation

RFQ NUMBER  
**COR61433**

PAGE  
**1**

ADDRESS CORRESPONDENCE TO ATTENTION OF  
**BUYER 32  
 304-558-2544**

RFQ COPY

TYPE NAME/ADDRESS HERE

Gity Window Systems, LLC  
 Rt. 2 Box 285  
 Clarksburg, WV 26301

DENMAR CORRECTIONAL CENTER

HC-64, BOX 125  
 DENMAR ROAD  
 HILLSBORD, WV  
 24946

DATE PRINTED	TERMS OF SALE	SHIP VIA	FOB	FREIGHT TERMS
07/15/2010				

BID OPENING DATE: **08/12/2010** BID OPENING TIME **01:30PM**

LINE	QUANTITY	UOP	CAT. NO.	ITEM NUMBER	UNIT PRICE	AMOUNT
0001	1	JB		910-65		
<p>WINDOW REPLACEMENT</p> <p>THE WEST VIRGINIA PURCHASING DIVISION, FOR THE AGENCY, THE WEST VIRGINIA DIVISION OF OF CORRECTIONS, IS SOLICITING BIDS FROM QUALIFIED CONTRACTORS TO PROVIDE ALL LABOR, MATERIALS, EQUIPMENT, AND SUPPLIES TO REPLACE ALL THE WINDOWS AT THE DENMAR CORRECTIONAL CENTER WITH ENERGY EFFICIENT MATERIALS PER THE FOLLOWING BID REQUIREMENTS, TERMS &amp; CONDITIONS, DRAWINGS, AND SPECIFICATIONS AS ATTACHED.</p> <p>THIS PROJECT IS FUNDED BY THE AMERICAN RECOVERY AND REINVESTMENT ACT (ARRA) AND IS SUBJECT TO ITS REQUIREMENTS AND BUY AMERICAN PROVISIONS AS CONTAINED HEREIN.</p> <p>THE MODEL/BRAND/SPECIFICATIONS NAMED HEREIN ESTABLISH THE ACCEPTABLE LEVEL OF QUALITY ONLY AND ARE NOT INTENDED TO REFLECT A PREFERENCE OR FAVOR ANY PARTICULAR BRAND OR VENDOR. VENDORS WHO ARE BIDDING ALTERNATES SHOULD SO STATE AND INCLUDE PERTINENT LITERATURE AND SPECIFICATIONS. FAILURE TO PROVIDE INFORMATION FOR ANY ALTERNATES MAY BE GROUNDS FOR REJECTION OF THE BID. THE STATE RESERVES THE RIGHT TO WAIVE MINOR IRREGULARITIES IN BIDS OR SPECIFICATION IN ACCORDANCE WITH SECTION 148-1-4(F) OF THE WEST VIRGINIA LEGISLATIVE RULES AND REGULATIONS.</p> <p>MANDATORY PRE-BID</p> <p>A MANDATORY PRE-BID WILL BE HELD ON 07/28/10 AT 1:30 P</p>						

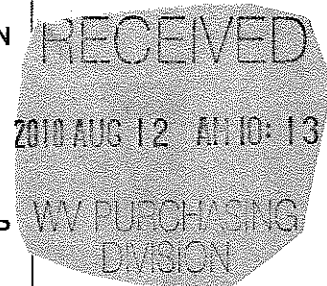

SEE REVERSE SIDE FOR TERMS AND CONDITIONS			
SIGNATURE <i>[Signature]</i>	TELEPHONE 304.623.2573	DATE 08/12/10	ADDRESS CHANGES TO BE NOTED ABOVE
TITLE Managing Member	FEIN 05-0592209		

WHEN RESPONDING TO RFQ, INSERT NAME AND ADDRESS IN SPACE ABOVE LABELED 'VENDOR'

## GENERAL TERMS & CONDITIONS REQUEST FOR QUOTATION (RFQ) AND REQUEST FOR PROPOSAL (RFP)

1. Awards will be made in the best interest of the State of West Virginia.
  2. The State may accept or reject in part, or in whole, any bid.
  3. Prior to any award, the apparent successful vendor must be properly registered with the Purchasing Division and have paid the required \$125 fee.
  4. All services performed or goods delivered under State Purchase Order/Contracts are to be continued for the term of the Purchase Order/Contracts, contingent upon funds being appropriated by the Legislature or otherwise being made available. In the event funds are not appropriated or otherwise available for these services or goods this Purchase Order/Contract becomes void and of no effect after June 30.
  5. Payment may only be made after the delivery and acceptance of goods or services.
  6. Interest may be paid for late payment in accordance with the *West Virginia Code*.
  7. Vendor preference will be granted upon written request in accordance with the *West Virginia Code*.
  8. The State of West Virginia is exempt from federal and state taxes and will not pay or reimburse such taxes.
  9. The Director of Purchasing may cancel any Purchase Order/Contract upon 30 days written notice to the seller.
  10. The laws of the State of West Virginia and the *Legislative Rules* of the Purchasing Division shall govern the purchasing process.
  11. Any reference to automatic renewal is hereby deleted. The Contract may be renewed only upon mutual written agreement of the parties.
  12. **BANKRUPTCY:** In the event the vendor/contractor files for bankruptcy protection, the State may deem this contract null and void, and terminate such contract without further order.
  13. **HIPAA BUSINESS ASSOCIATE ADDENDUM:** The West Virginia State Government HIPAA Business Associate Addendum (BAA), approved by the Attorney General, is available online at [www.state.wv.us/admin/purchase/vrc/hipaa.htm](http://www.state.wv.us/admin/purchase/vrc/hipaa.htm) and is hereby made part of the agreement. Provided that the Agency meets the definition of a Cover Entity (45 CFR §160.103) and will be disclosing Protected Health Information (45 CFR §160.103) to the vendor.
  14. **CONFIDENTIALITY:** The vendor agrees that he or she will not disclose to anyone, directly or indirectly, any such personally identifiable information or other confidential information gained from the agency, unless the individual who is the subject of the information consents to the disclosure in writing or the disclosure is made pursuant to the agency's policies, procedures, and rules. Vendor further agrees to comply with the Confidentiality Policies and Information Security Accountability Requirements, set forth in <http://www.state.wv.us/admin/purchase/privacy/noticeConfidentiality.pdf>.
  15. **LICENSING:** Vendors must be licensed and in good standing in accordance with any and all state and local laws and requirements by any state or local agency of West Virginia, including, but not limited to, the West Virginia Secretary of State's Office, the West Virginia Tax Department, and the West Virginia Insurance Commission. The vendor must provide all necessary releases to obtain information to enable the director or spending unit to verify that the vendor is licensed and in good standing with the above entities.
  16. **ANTITRUST:** In submitting a bid to any agency for the State of West Virginia, the bidder offers and agrees that if the bid is accepted the bidder will convey, sell, assign or transfer to the State of West Virginia all rights, title and interest in and to all causes of action it may now or hereafter acquire under the antitrust laws of the United States and the State of West Virginia for price fixing and/or unreasonable restraints of trade relating to the particular commodities or services purchased or acquired by the State of West Virginia. Such assignment shall be made and become effective at the time the purchasing agency tenders the initial payment to the bidder.
- I certify that this bid is made without prior understanding, agreement, or connection with any corporation, firm, limited liability company, partnership, or person or entity submitting a bid for the same material, supplies, equipment or services and is in all respects fair and without collusion or Fraud. I further certify that I am authorized to sign the certification on behalf of the bidder or this bid.

### INSTRUCTIONS TO BIDDERS

1. Use the quotation forms provided by the Purchasing Division. Complete all sections of the quotation form.
2. Items offered must be in compliance with the specifications. Any deviation from the specifications must be clearly indicated by the bidder. Alternates offered by the bidder as **EQUAL** to the specifications must be clearly defined. A bidder offering an alternate should attach complete specifications and literature to the bid. The Purchasing Division may waive minor deviations to specifications.
3. Unit prices shall prevail in case of discrepancy. All quotations are considered F.O.B. destination unless alternate shipping terms are clearly identified in the quotation.
4. All quotations must be delivered by the bidder to the office listed below prior to the date and time of the bid opening. Failure of the bidder to deliver the quotations on time will result in bid disqualifications: Department of Administration, Purchasing Division, 2019 Washington Street East, P.O. Box 50130, Charleston, WV 25305-0130
5. Communication during the solicitation, bid, evaluation or award periods, except through the Purchasing Division, is strictly prohibited (W.Va. C.S.R. §148-1-6.6).



State of West Virginia  
 Department of Administration  
 Purchasing Division  
 2019 Washington Street East  
 Post Office Box 50130  
 Charleston, WV 25305-0130

# Request for Quotation

RFQ NUMBER  
**CDR61433**

PAGE  
**2**

ADDRESS CORRESPONDENCE TO ATTENTION OF  
**BUYER 32  
 304-558-2544**

**RFQ COPY**  
**TYPE NAME/ADDRESS HERE**  
**VENDOR**  
 City Window Systems, LLC  
 Rt. 2 Box 285  
 Clarksburg, WV 26301

**SHIP TO**  
**DENMAR CORRECTIONAL CENTER**  
 HC-64, BOX 125  
 DENMAR ROAD  
 HILLSBORO, WV  
 24946

DATE PRINTED <b>07/15/2010</b>	TERMS OF SALE	SHIP VIA	F.O.B.	FREIGHT TERMS
-----------------------------------	---------------	----------	--------	---------------

BID OPENING DATE: **08/12/2010** BID OPENING TIME **01:30PM**

LINE	QUANTITY	UOP	CAT NO.	ITEM NUMBER	UNIT PRICE	AMOUNT
<p>AT THE DENMAR CORRECTIONAL CENTER LOCATED AT HC 64, BOX 125, HILLSBORO, WV 24946. VENDORS ARE REQUIRED TO CONTACT THE DIVISION OF CORRECTIONS AT 304.558.2036 EXT. 53456 TO PRE-REGISTER FOR ATTENDANCE.</p> <p>INTERESTED PARTIES ARE REQUIRED TO ATTEND THIS MEETING FAILURE TO ATTEND THE MANDATORY PRE-BID SHALL RESULT IN DISQUALIFICATION OF THE BID. NO ONE PERSON MAY REPRESENT MORE THAN ONE BIDDER.</p> <p>AN ATTENDANCE SHEET WILL BE MADE AVAILABLE FOR ALL POTENTIAL BIDDERS TO COMPLETE. THIS WILL SERVE AS THE OFFICIAL DOCUMENT VERIFYING ATTENDANCE AT THE MANDATORY PRE-BID. FAILURE TO PROVIDE YOUR COMPANY AND REPRESENTATIVE NAME ON THE ATTENDANCE SHEET WILL RESULT IN DISQUALIFICATION OF THE BID. THE STATE WILL NOT ACCEPT ANY OTHER DOCUMENTATION TO VERIFY ATTENDANCE. THE BIDDER IS RESPONSIBLE FOR ENSURING THEY HAVE COMPLETED THE INFORMATION REQUIRED ON THE ATTENDANCE SHEET. THE PURCHASING DIVISION AND THE STATE AGENCY WILL NOT ASSUME ANY RESPONSIBILITY FOR A BIDDER-S FAILURE TO COMPLETE THE PRE-BID ATTENDANCE SHEET. IN ADDITION, WE REQUEST THAT ALL POTENTIAL BIDDERS INCLUDE THEIR E-MAIL ADDRESS AND FAX NUMBER.</p> <p>ALL POTENTIAL BIDDERS ARE REQUESTED TO ARRIVE PRIOR TO THE STARTING TIME FOR THE PRE-BID. BIDDERS WHO ARRIVE LATE, BUT PRIOR TO THE DISMISSAL OF THE TECHNICAL PORTION OF THE PRE-BID WILL BE PERMITTED TO SIGN IN. BIDDERS WHO ARRIVE AFTER CONCLUSION OF THE TECHNICAL PORTION OF THE PRE-BID, BUT DURING ANY SUBSEQUENT PART OF THE PRE-BID WILL NOT BE PERMITTED TO SIGN THE ATTENDANCE SHEET.</p> <p>EXHIBIT 5</p>						

SEE REVERSE SIDE FOR TERMS AND CONDITIONS

SIGNATURE 	TELEPHONE 304.623.2573	DATE 08/12/10
TITLE Managing Member	FEIN 05-0592209	ADDRESS CHANGES TO BE NOTED ABOVE

WHEN RESPONDING TO RFQ, INSERT NAME AND ADDRESS IN SPACE ABOVE LABELED 'VENDOR'



State of West Virginia  
 Department of Administration  
 Purchasing Division  
 2019 Washington Street East  
 Post Office Box 50130  
 Charleston, WV 25305-0130

# Request for Quotation

RFQ NUMBER  
**COR61433**

PAGE  
**3**

ADDRESS CORRESPONDENCE TO ATTENTION OF  
**BUYER 32  
 304-558-2544**

VENDOR

RFQ COPY  
 TYPE NAME/ADDRESS HERE

City Window Systems, LLC  
 Rt. 2 Box 285  
 Clarksburg, WV 26301

SHIP TO

DENMAR CORRECTIONAL CENTER  
 HC-64, BOX 125  
 DENMAR ROAD  
 HILLSBORO, WV  
 24946

DATE PRINTED	TERMS OF SALE	SHIP VIA	F.O.B.	FREIGHT TERMS
07/15/2010				

BID OPENING DATE: **08/12/2010** BID OPENING TIME **01:30PM**

LINE	QUANTITY	UOP	CAT NO	ITEM NUMBER	UNIT PRICE	AMOUNT
<p>WEST VIRGINIA CODE 21-1D-5 PROVIDES THAT: ANY SOLICITATION FOR A PUBLIC IMPROVEMENT CONSTRUCTION CONTRACT REQUIRES EACH VENDOR THAT SUBMITS A BID FOR THE WORK TO SUBMIT AT THE SAME TIME AN AFFIDAVIT OF COMPLIANCE WITH THE BID. THE ENCLOSED DRUG-FREE WORKPLACE AFFIDAVIT MUST BE SIGNED AND SUBMITTED WITH THE BID AS EVIDENCE OF THE VENDOR'S COMPLIANCE WITH THE PROVISIONS OF ARTICLE 1D, CHAPTER 21 OF THE WEST VIRGINIA CODE. FAILURE TO SUBMIT THE SIGNED DRUG-FREE WORKPLACE AFFIDAVIT WITH THE BID SHALL RESULT IN DISQUALIFICATION OF SUCH BID.</p> <p>NOTICE TO PROCEED: THIS CONTRACT IS TO BE PERFORMED WITHIN XXXX CALENDAR DAYS AFTER THE NOTICE TO PROCEED IS RECEIVED. UNLESS OTHERWISE SPECIFIED, THE FULLY EXECUTED PURCHASE ORDER WILL BE CONSIDERED NOTICE TO PROCEED.</p> <p>CANCELLATION: THE DIRECTOR OF PURCHASING RESERVES THE RIGHT TO CANCEL THIS CONTRACT IMMEDIATELY UPON WRITTEN NOTICE TO THE VENDOR IF THE MATERIALS OR WORKMANSHIP SUPPLIED ARE OF AN INFERIOR QUALITY OR DO NOT CONFORM WITH THE SPECIFICATIONS OF THE BID AND CONTRACT HERE IN.</p> <p>WAGE RATES: THE CONTRACTOR OR SUBCONTRACTOR SHALL PAY THE HIGHER OF THE U.S. DEPARTMENT OF LABOR MINIMUM WAGE RATES AS ESTABLISHED FOR POCAHONTAS COUNTY, PURSUANT TO WEST VIRGINIA CODE 21-5A, ET, SEQ. (PREVAILING WAGE RATES APPLY TO THIS PROJECT)</p> <p>ARBITRATION: ANY REFERENCES MADE TO ARBITRATION OR INTEREST FOR PAYMENTS DUE (EXCEPT FOR ANY INTEREST REQUIRED BY STATE LAW) CONTAINED IN THIS CONTRACT OR IN ANY AMERICAN INSTITUTE OF ARCHITECTS DOCUMENTS PERTAINING TO THIS CONTRACT ARE HEREBY DELETED.</p>						

SEE REVERSE SIDE FOR TERMS AND CONDITIONS

SIGNATURE <i>[Signature]</i>	TELEPHONE 304.623.2573	DATE 08/12/10
TITLE Managing Member	FEIN 05-0592209	ADDRESS CHANGES TO BE NOTED ABOVE

WHEN RESPONDING TO RFQ INSERT NAME AND ADDRESS IN SPACE ABOVE LABELED 'VENDOR'



State of West Virginia  
 Department of Administration  
 Purchasing Division  
 2019 Washington Street East  
 Post Office Box 50130  
 Charleston, WV 25305-0130

# Request for Quotation

RFQ NUMBER  
**COR61433**

PAGE  
**4**

ADDRESS CORRESPONDENCE TO ATTENTION OF  
**BUYER 32  
 304-558-2544**

RFQ COPY

TYPE NAME/ADDRESS HERE

City Window Systems, LLC  
 Rt. 2 Box 285  
 Clarksburg, WV 26301

DENMAR CORRECTIONAL CENTER

HC-64, BOX 125  
 DENMAR ROAD  
 HILLSBORO, WV  
 24946

DATE PRINTED	TERMS OF SALE	SHIP VIA	F.O.B.	FREIGHT TERMS
07/15/2010				

BID OPENING DATE: **08/12/2010** BID OPENING TIME **01:30PM**

LINE	QUANTITY	UOP	CAT NO	ITEM NUMBER	UNIT PRICE	AMOUNT
<p>WORKERS' COMPENSATION: VENDOR IS REQUIRED TO PROVIDE A CERTIFICATE FROM WORKERS' COMPENSATION IF SUCCESSFUL.</p> <p>ALL OF THE ITEMS CHECKED BELOW WILL BE A REQUIREMENT OF THIS CONTRACT:</p> <p>(XX) INSURANCE: SUCCESSFUL VENDOR SHALL FURNISH PROOF OF COMMERCIAL GENERAL LIABILITY INSURANCE PRIOR TO ISSUANCE OF CONTRACT. UNLESS OTHERWISE SPECIFIED IN THE BID DOCUMENTS, THE MINIMUM AMOUNT OF INSURANCE COVERAGE REQUIRED IS \$250,000.</p> <p>( ) BUILDERS RISK INSURANCE: SUCCESSFUL VENDOR SHALL FURNISH PROOF OF BUILDERS RISK - ALL RISK INSURANCE IN AN AMOUNT EQUAL TO 100% OF THE AMOUNT OF THE CONTRACT.</p> <p>(XX) BONDS: FIVE PERCENT (5%) OF THE TOTAL AMOUNT OF THE BID PAYABLE TO THE STATE OF WEST VIRGINIA, SHALL BE SUBMITTED WITH EACH BID AS A BID BOND. THE SUCCESSFUL BIDDER SHALL ALSO FURNISH A PERFORMANCE BOND AND LABOR/MATERIAL BOND FOR 100% OF THE AMOUNT OF THE CONTRACT. BONDS MAY BE PROVIDED IN THE FORM OF A CERTIFIED CHECK, IRREVOCABLE LETTER OF CREDIT, OR BOND FURNISHED BY A SOLVENT SURETY COMPANY AUTHORIZED TO DO BUSINESS IN THE STATE OF WEST VIRGINIA. A LETTER OF CREDIT SUBMITTED IN LIEU OF A BOND WILL ONLY BE ALLOWED FOR PROJECTS UNDER \$100,000. PERSONAL OR BUSINESS CHECKS ARE NOT ACCEPTABLE IN LIEU OF THE 5% BID BOND, PERFORMANCE BOND, OR LABOR AND MATERIAL BOND.</p> <p>( ) MAINTENANCE BOND: A TWO (2) YEAR MAINTENANCE BOND COVERING THE ROOFING SYSTEM WILL BE A REQUIREMENT OF THE SUCCESSFUL VENDOR.</p> <p>REV. 11/00</p>						

SEE REVERSE SIDE FOR TERMS AND CONDITIONS

SIGNATURE <i>[Signature]</i>	TELEPHONE 304.623.2573	DATE 08/12/10
TITLE Managing Member	FEIN 05-0592209	ADDRESS CHANGES TO BE NOTED ABOVE

WHEN RESPONDING TO RFQ INSERT NAME AND ADDRESS IN SPACE ABOVE LABELED 'VENDOR'



State of West Virginia  
 Department of Administration  
 Purchasing Division  
 2019 Washington Street East  
 Post Office Box 50130  
 Charleston, WV 25305-0130

# Request for Quotation

RFQ NUMBER  
**COR61433**

PAGE  
**5**

ADDRESS CORRESPONDENCE TO ATTENTION OF  
**BUYER 32**  
**304-558-2544**

RFQ COPY

TYPE NAME/ADDRESS HERE

City Window Systems, LLC  
 Rt. 2 Box 285  
 Clarksburg, WV 26301

VENDOR

DENMAR CORRECTIONAL CENTER

HC-64, BOX 125  
 DENMAR ROAD  
 HILLSBORO, WV  
 24946

SHIP TO

DATE PRINTED	TERMS OF SALE	SHIP VIA	F.O.B.	FREIGHT TERMS
07/15/2010				

BID OPENING DATE: **08/12/2010**      BID OPENING TIME **01:30PM**

LINE	QUANTITY	UOP	CAT NO	ITEM NUMBER	UNIT PRICE	AMOUNT
<p><b>EXHIBIT 7</b></p> <p><b>DOMESTIC ALUMINUM, GLASS &amp; STEEL IN PUBLIC WORKS PROJECTS</b></p> <p>IN ACCORDANCE WITH WEST VIRGINIA CODE 5-19-1 ET., SEQ., EVERY CONTRACT FOR CONSTRUCTION, RECONSTRUCTION, ALTERATION, REPAIR, IMPROVEMENT OR MAINTENANCE OF PUBLIC WORKS, WHERE THE COST IS MORE THAN \$50,000 AND, IN THE CASE OF STEEL ONLY, WHERE THE COST OF STEEL IS MORE THAN \$50,000 OR WHERE MORE THAN 10,000 POUNDS OF STEEL ARE REQUIRED, THE STATE WILL ACCEPT ONLY ALUMINUM GLASS, OR STEEL PRODUCTS PRODUCED IN THE UNITED STATES. IN ADDITION, ITEMS OF MACHINERY OR EQUIPMENT PURCHASED FOR USE AT THE SITE OF PUBLIC WORKS SHALL BE MADE OF DOMESTIC ALUMINUM, GLASS OR STEEL, UNLESS THE COST OF THE PRODUCT IS LESS THAN \$50,000 OR LESS THAN 10,000 POUNDS OF STEEL ARE USED IN PUBLIC WORKS PROJECTS.</p> <p>FOREIGN MADE ALUMINUM, GLASS OR STEEL PRODUCTS MAY BE ACCEPTED ONLY IF THE COST OF DOMESTIC PRODUCTS IS FOUND TO BE UNREASONABLE. SUCH COST IS UNREASONABLE IF IT IS 20% OR MORE HIGHER THAN THE BID PRICE FOR FOREIGN MADE PRODUCTS. IF THE DOMESTIC ALUMINUM, GLASS OR STEEL PRODUCTS TO BE SUPPLIED OR PRODUCED IN A "SUBSTANTIAL LABOR SURPLUS AREA", AS DEFINED BY THE UNITED STATES DEPARTMENT OF LABOR, FOREIGN PRODUCTS MAY BE SUPPLIED ONLY IF DOMESTIC PRODUCTS ARE 30% OR MORE HIGHER IN PRICE THAN THE FOREIGN MADE PRODUCTS.</p> <p>IF, PRIOR TO THE AWARD OF A CONTRACT UNDER THE ABOVE PROVISIONS, THE SPENDING OFFICER OF THE SPENDING UNIT DETERMINES THAT THERE EXISTS A BID FOR LIKE FOREIGN ALUMINUM, GLASS OR STEEL THAT IS REASONABLE AND LOWER THAN THE LOWEST BID DOMESTIC PRODUCTS, THE SPENDING</p>						

SEE REVERSE SIDE FOR TERMS AND CONDITIONS

SIGNATURE <i>Ron Deuss</i>	TELEPHONE 304.623.2573	DATE 08/12/10
TITLE Managing Member	FEIN 05-0592209	ADDRESS CHANGES TO BE NOTED ABOVE

WHEN RESPONDING TO RFQ INSERT NAME AND ADDRESS IN SPACE ABOVE LABELED 'VENDOR'



State of West Virginia  
 Department of Administration  
 Purchasing Division  
 2019 Washington Street East  
 Post Office Box 50130  
 Charleston, WV 25305-0130

# Request for Quotation

RFQ NUMBER  
**COR61433**

PAGE  
**6**

ADDRESS CORRESPONDENCE TO ATTENTION OF  
**BUYER 32**  
**304-558-2544**

RFQ COPY

TYPE NAME/ADDRESS HERE

V  
E  
N  
D  
O  
R

City Window Systems, LLC  
 Rt. 2 Box 285  
 Clarksburg, WV 26301

S  
H  
I  
P  
T  
O

DENMAR CORRECTIONAL CENTER  
 HC-64, BOX 125  
 DENMAR ROAD  
 HILLSBORO, WV  
 24946

DATE PRINTED	TERMS OF SALE	SHIP VIA	F.O.B.	FREIGHT TERMS
07/15/2010				

BID OPENING DATE: **08/12/2010** BID OPENING TIME **01:30PM**

LINE	QUANTITY	UOP	CAT NO	ITEM NUMBER	UNIT PRICE	AMOUNT
<p>OFFICE MAY REQUEST, IN WRITING, A REEVALUATION AND REDUCTION IN THE LOWEST BID FOR SUCH DOMESTIC PRODUCTS. ALL VENDORS MUST INDICATE IN THEIR BID IF THEY ARE SUPPLYING FOREIGN ALUMINUM, GLASS OR STEEL.</p> <p>REV. 3/88</p> <p>PREFERENCE FOR USE OF DOMESTIC STEEL PRODUCTS</p> <p>1. EXCEPT WHEN AUTHORIZED BY THE DIRECTOR OF THE PURCHASING DIVISION PURSUANT TO SUBSECTION 2 BELOW NO CONTRACTOR MAY USE OR SUPPLY STEEL PRODUCTS FOR A STATE CONTRACT PROJECT OTHER THAN THOSE STEEL PRODUCTS MADE IN THE UNITED STATES. AS USED USED IN THIS CONTRACT,</p> <p>A. "STATE CONTRACT PROJECT" MEANS ANY ERECTION OR CONSTRUCTION OF, OR ANY ADDITION TO, ALTERATION OF OR OTHER IMPROVEMENT TO ANY BUILDING OR STRUCTURE, INCLUDING, BUT NOT LIMITED TO, ROADS OR HIGHWAYS, OR THE INSTALLATION OF ANY HEATING OR COOLING OR VENTILATING PLANTS OR OTHER EQUIPMENT, OR THE SUPPLY OF AND MATERIALS FOR SUCH PROJECTS, PURSUANT TO A CONTRACT WITH THE STATE OF WEST VIRGINIA FOR WHICH BIDS WERE SOLICITED ON OR AFTER JUNE 6, 2001.</p> <p>B. "STEEL PRODUCTS" MEANS PRODUCTS ROLLED, FORMED, SHAPED, DRAWN, EXTRUDED, FORGED, CAST, FABRICATED OR OTHERWISE SIMILARLY PROCESSED, OR PROCESSED BY A COMBINATION OF TWO OR MORE OF SUCH OPERATIONS, FROM STEEL MADE BY THE OPEN HEARTH, BASIC OXYGEN, ELECTRIC FURNACE, BESSEMER OR OTHER STEEL MAKING PROCESS.</p>						

SEE REVERSE SIDE FOR TERMS AND CONDITIONS

SIGNATURE *Ron* TELEPHONE 304.623.2573 DATE 08/12/10

TITLE *Managing Member* FEIN 05-0592209 ADDRESS CHANGES TO BE NOTED ABOVE

WHEN RESPONDING TO RFQ, INSERT NAME AND ADDRESS IN SPACE ABOVE LABELED 'VENDOR'







State of West Virginia  
 Department of Administration  
 Purchasing Division  
 2019 Washington Street East  
 Post Office Box 50130  
 Charleston, WV 25305-0130

# Request for Quotation

RFQ NUMBER  
**COR61433**

PAGE  
**8**

ADDRESS CORRESPONDENCE TO ATTENTION OF  
**BUYER 32  
 304-558-2544**

RFQ COPY

TYPE NAME/ADDRESS HERE

City Window Systems, LLC  
 Rt. 2 Box 285  
 Clarksburg, WV 26301

DENMAR CORRECTIONAL CENTER

HC-64, BOX 125  
 DENMAR ROAD  
 HILLSBORO, WV  
 24946

DATE PRINTED	TERMS OF SALE	SHIP VIA	F.O.B.	FREIGHT TERMS
07/15/2010				

BID OPENING DATE: **08/12/2010** BID OPENING TIME **01:30PM**

LINE	QUANTITY	UOP	CAT NO	ITEM NUMBER	UNIT PRICE	AMOUNT
<p>THE ARCHITECT/ENGINEER AND/OR AGENCY SHALL BE REQUIRED TO ABIDE BY THE FOLLOWING SCHEDULE IN ISSUING CONSTRUCTION PROJECT ADDENDA FOR STATE AGENCIES:</p> <p>(1) THE ARCHITECT/ENGINEER SHALL PREPARE THE ADDENDUM AND A LIST OF ALL PARTIES THAT HAVE PROCURED DRAWINGS AND SPECIFICATIONS FOR THE PROJECT. THE ADDENDUM AND LIST SHALL BE FORWARDED TO THE BUYER IN THE STATE PURCHASING DIVISION. THE ARCHITECT/ENGINEER SHALL ALSO SEND A COPY OF THE ADDENDUM TO THE STATE AGENCY FOR WHICH THE CONTRACT IS ISSUED.</p> <p>(2) THE BUYER SHALL SEND THE ADDENDUM TO ALL INTERESTED PARTIES AND, IF NECESSARY, EXTEND THE BID OPENING DATE. ANY ADDENDUM SHOULD BE RECEIVED BY THE BUYER WITHIN FOURTEEN (14) DAYS PRIOR TO THE BID OPENING DATE.</p> <p>(3) ALL ADDENDA SHOULD BE FORMALLY ACKNOWLEDGED BY ALL BIDDERS AND SUBMITTED TO THE STATE PURCHASING DIVISION. THE SAME RULES AND REGULATIONS THAT APPLY TO THE ORIGINAL BIDDING DOCUMENT SHALL ALSO APPLY TO AN ADDENDUM DOCUMENT. THE ONLY EXCEPTION MAY BE FOR AN ADDENDUM THAT IS ISSUED FOR THE SOLE PURPOSE OF CHANGING A BID OPENING TIME AND/OR DATE.</p> <p>REV. 11/96</p> <p>EXHIBIT 10</p> <p>ADDENDUM ACKNOWLEDGEMENT</p> <p>I HEREBY ACKNOWLEDGE RECEIPT OF THE FOLLOWING CHECKED ADDENDUM(S) AND HAVE MADE THE NECESSARY REVISIONS TO</p>						

SEE REVERSE SIDE FOR TERMS AND CONDITIONS

SIGNATURE <i>[Signature]</i>	TELEPHONE 304.623.2573	DATE 08/12/10
------------------------------	---------------------------	------------------

TITLE Managing Member	FEIN 05-0592209	ADDRESS CHANGES TO BE NOTED ABOVE
--------------------------	--------------------	-----------------------------------

WHEN RESPONDING TO REQ. INSERT NAME AND ADDRESS IN SPACE ABOVE LABELLED 'VENDOR'



State of West Virginia  
 Department of Administration  
 Purchasing Division  
 2019 Washington Street East  
 Post Office Box 50130  
 Charleston, WV 25305-0130

# Request for Quotation

RFQ NUMBER  
**COR61433**

PAGE  
**9**

ADDRESS CORRESPONDENCE TO ATTENTION OF  
**BUYER 32  
 304-558-2544**

VENDOR

**RFQ COPY**  
**TYPE NAME/ADDRESS HERE**  
 City Window Systems, LLC  
 Rt. 2 Box 285  
 Clarksburg, WV 26301

SHIP TO

**DENMAR CORRECTIONAL CENTER**  
  
 HC-64, BOX 125  
 DENMAR ROAD  
 HILLSBORO, WV  
 24946

DATE PRINTED <b>07/15/2010</b>	TERMS OF SALE	SHIP VIA	F.O.B.	FREIGHT TERMS
BID OPENING DATE: <b>08/12/2010</b> <b>BID OPENING TIME 01:30PM</b>				

LINE	QUANTITY	UOP	CAT NO	ITEM NUMBER	UNIT PRICE	AMOUNT
MY PROPOSAL, PLANS AND/OR SPECIFICATION, ETC.						
ADDENDUM NOS.:						
NO. 1		X				
NO. 2						
NO. 3						
NO. 4						
NO. 5						
I UNDERSTAND THAT FAILURE TO CONFIRM THE RECEIPT OF THE ADDENDUM(S) MAY BE CAUSE FOR REJECTION OF THE BIDS.						
VENDOR MUST CLEARLY UNDERSTAND THAT ANY VERBAL REPRESENTATION MADE OR ASSUMED TO BE MADE DURING ANY ORAL DISCUSSION HELD BETWEEN VENDOR'S REPRESENTATIVES AND ANY STATE PERSONNEL IS NOT BINDING. ONLY THE INFORMATION ISSUED IN WRITING AND ADDED TO THE SPECIFICATIONS BY AN OFFICIAL ADDENDUM IS BINDING.						
 .....SIGNATURE						
...City Window Systems, LLC.....				COMPANY		
...August 12, 2010.....				DATE		
REV. 11/96						
CONTRACTORS LICENSE						

SEE REVERSE SIDE FOR TERMS AND CONDITIONS

SIGNATURE 	TELEPHONE 304.623.2573	DATE 08/12/10
TITLE Managing Member	FEIN 05-0592209	ADDRESS CHANGES TO BE NOTED ABOVE

WHEN RESPONDING TO RFQ INSERT NAME AND ADDRESS IN SPACE ABOVE I AM AN 'VENDOR'



State of West Virginia  
 Department of Administration  
 Purchasing Division  
 2019 Washington Street East  
 Post Office Box 50130  
 Charleston, WV 25305-0130

# Request for Quotation

RFQ NUMBER  
**COR61433**

PAGE  
**10**

ADDRESS CORRESPONDENCE TO ATTENTION OF  
**BUYER 32  
 304-558-2544**

RFQ COPY

TYPE NAME/ADDRESS HERE

City Window Systems, LLC  
 Rt. 2 Box 285  
 Clarksburg, WV 26301

DENMAR CORRECTIONAL CENTER

HC-64, BOX 125  
 DENMAR ROAD  
 HILLSBORO, WV  
 24946

DATE PRINTED	TERMS OF SALE	SHIP VIA	F.O.B.	FREIGHT TERMS
07/15/2010				
BID OPENING DATE: 08/12/2010		BID OPENING TIME 01:30PM		

LINE	QUANTITY	UOP	CAT NO	ITEM NUMBER	UNIT PRICE	AMOUNT
<p>WEST VIRGINIA STATE CODE 21-11-2 REQUIRES THAT ALL PERSONS DESIRING TO PERFORM CONTRACTING WORK IN THIS STATE MUST BE LICENSED. THE WEST VIRGINIA CONTRACTORS LICENSING BOARD IS EMPOWERED TO ISSUE THE CONTRACTORS LICENSE. APPLICATIONS FOR A CONTRACTORS LICENSE MAY BE MADE BY CONTACTING THE WEST VIRGINIA DIVISION OF LABOR CAPITOL COMPLEX, BUILDING 3, ROOM 319, CHARLESTON, WV 25305. TELEPHONE: (304) 558-7890.</p> <p>WEST VIRGINIA STATE CODE 21-11-11 REQUIRES ANY PROSPECTIVE BIDDER TO INCLUDE THE CONTRACTORS LICENSE NUMBER ON THEIR BID.</p> <p>BIDDER TO COMPLETE:            CONTRACTORS NAME: City Window Systems, LLC            CONTRACTORS LICENSE NO.: WY038038</p> <p>THE SUCCESSFUL BIDDER WILL BE REQUIRED TO FURNISH A COPY OF THEIR CONTRACTORS LICENSE PRIOR TO ISSUANCE OF A PURCHASE ORDER/CONTRACT</p> <p>APPLICABLE LAW</p> <p>THE WEST VIRGINIA STATE CODE, PURCHASING DIVISION RULES AND REGULATIONS, AND THE INFORMATION PROVIDED IN THE "REQUEST FOR QUOTATION" ISSUED BY THE PURCHASING DIVISION IS THE SOLE AUTHORITY GOVERNING THIS PROCUREMENT.</p> <p>ANY INFORMATION PROVIDED IN SPECIFICATION MANUALS, OR ANY OTHER SOURCE, VERBAL OR WRITTEN, WHICH CONTRADICTS OR ALTERS THE INFORMATION PROVIDED FROM THE SOURCES AS DESCRIBED IN THE ABOVE PARAGRAPH IS VOID AND OF NO EFFECT.</p>						

SEE REVERSE SIDE FOR TERMS AND CONDITIONS

SIGNATURE 	TELEPHONE 304.623.2573	DATE 08/12/10
TITLE Managing Member	FEIN 05-0592209	ADDRESS CHANGES TO BE NOTED ABOVE

WHEN RESPONDING TO RFQ, INSERT NAME AND ADDRESS IN SPACE ABOVE LABELLED 'VENDOR'



State of West Virginia  
 Department of Administration  
 Purchasing Division  
 2019 Washington Street East  
 Post Office Box 50130  
 Charleston, WV 25305-0130

# Request for Quotation

RFO NUMBER  
**COR61433**

PAGE  
**11**

ADDRESS CORRESPONDENCE TO ATTENTION OF  
**BUYER 32**  
**304-558-2544**

RFQ COPY

TYPE NAME/ADDRESS HERE

City Window Systems, LLC  
 Rt. 2 Box 285  
 Clarksburg, WV 26301

DENMAR CORRECTIONAL CENTER

HC-64, BOX 125  
 DENMAR ROAD  
 HILLSBORO, WV  
 24946

DATE PRINTED	TERMS OF SALE	SHIP VIA	F.O.B.	FREIGHT TERMS
07/15/2010				

BID OPENING DATE: **08/12/2010** BID OPENING TIME **01:30PM**

LINE	QUANTITY	UOP	CAT NO	ITEM NUMBER	UNIT PRICE	AMOUNT
<p><b>BANKRUPTCY: IN THE EVENT THE VENDOR/CONTRACTOR FILES FOR BANKRUPTCY PROTECTION, THE STATE MAY DEEM THE CONTRACT NULL AND VOID, AND TERMINATE SUCH CONTRACT WITHOUT FURTHER ORDER.</b></p> <p>REV. 5/2009</p> <p style="text-align: center;"><b>NOTICE</b></p> <p><b>A SIGNED BID MUST BE SUBMITTED TO:</b></p> <p style="text-align: center;"><b>DEPARTMENT OF ADMINISTRATION          PURCHASING DIVISION          BUILDING 15          2019 WASHINGTON STREET, EAST          CHARLESTON, WV 25305-0130</b></p> <p><b>THE BID SHOULD CONTAIN THIS INFORMATION ON THE FACE OF THE ENVELOPE OR THE BID MAY NOT BE CONSIDERED:</b></p> <p><b>SEALED BID</b></p> <p><b>BUYER: 32</b></p> <p><b>REQ. NO.: COR61433</b></p> <p><b>BID OPENING DATE: 08/12/2010</b></p> <p><b>BID OPENING TIME: 1:30 PM</b></p> <p><b>PLEASE PROVIDE A FAX NUMBER IN CASE IT IS NECESSARY TO CONTACT YOU REGARDING YOUR BID:</b></p>						

SEE REVERSE SIDE FOR TERMS AND CONDITIONS

SIGNATURE *Ron Hewson* TELEPHONE 304.623.2573 DATE 08/12/10

TITLE **Managing Member** FEIN 05-0592209 ADDRESS CHANGES TO BE NOTED ABOVE

WHEN RESPONDING TO REQ. INSERT NAME AND ADDRESS IN SPACE ABOVE LABELLED 'VENDOR'



State of West Virginia  
 Department of Administration  
 Purchasing Division  
 2019 Washington Street East  
 Post Office Box 50130  
 Charleston, WV 25305-0130

# Request for Quotation

RFQ NUMBER  
**COR61433**

PAGE  
**12**

ADDRESS CORRESPONDENCE TO ATTENTION OF  
**BUYER 32  
 304-558-2544**

RFQ COPY

TYPE NAME/ADDRESS HERE

City Window Systems, LLC  
 Rt. 2 Box 285  
 Clarksburg, WV 26301

SHIP TO

DENMAR CORRECTIONAL CENTER  
 HC-64, BOX 125  
 DENMAR ROAD  
 HILLSBORO, WV  
 24946

DATE PRINTED	TERMS OF SALE	SHIP VIA	FOB	FREIGHT TERMS
07/15/2010				

BID OPENING DATE: **08/12/2010** BID OPENING TIME **01:30PM**

LINE	QUANTITY	UOP	CAT NO	ITEM NUMBER	UNIT PRICE	AMOUNT
				304.623.3775		
PLEASE PRINT OR TYPE NAME OF PERSON TO CONTACT CONCERNING THIS QUOTE: Ron Henderson						
***** THIS IS THE END OF RFQ COR61433 ***** TOTAL: _____						

SEE REVERSE SIDE FOR TERMS AND CONDITIONS

SIGNATURE <i>Ron Henderson</i>	TELEPHONE 304.623.2573	DATE 08/12/10
TITLE Managing Member	FEIN 05-0592209	ADDRESS CHANGES TO BE NOTED ABOVE

WHEN RESPONDING TO REQ. INSERT NAME AND ADDRESS IN SPACE ABOVE LABELLED 'VENDOR'

**SECTION 085113 - ALUMINUM WINDOWS (Commercial)****PART 1 - GENERAL**

## 1.01 SECTION INCLUDES

- A. Material: aluminum windows as on the drawings and specified in this section.
- B. Installation: labor, tools, and material needed to install aluminum windows.
- C. Glass and glazing.

## 1.02 RELATED SECTIONS - Section 079200 – Joint Sealants

## 1.03 REFERENCES

- A. AAMA - American Architectural Manufacturers Association - *www.aamanet.org*
  - 1. AAMA/WDMA/CSA 101/I.S.2/A440-05 "Standard/Specification for Windows, Doors, and Unit Skylights"
  - 2. AAMA 502-08 "Voluntary Specification for Field Testing of Newly Installed Fenestration Products"
  - 3. AAMA 611-98 "Voluntary Specification for Anodized Architectural Aluminum"
  - 4. AAMA 701/702-04 "Voluntary Specification for Pile Weatherstripping and Replaceable Fenestration Weatherseals"
  - 5. AAMA 800-07 "Voluntary Specifications and Test Methods for Sealants"
  - 6. AAMA 902-07 "Voluntary Specification for Sash Balances"
  - 7. AAMA 2603-02 "Voluntary Specification, Performance Requirements and Test Procedures for Pigmented Organic Coatings on Aluminum Extrusions and Panels"
  - 8. AAMA 2604-05 "Voluntary Specification, Performance Requirements and Test Procedures for High Performance Organic Coatings on Aluminum Extrusions and Panels"
  - 9. AAMA CW-10-04 "Care and Handling of Architectural Aluminum from Shop to Site"
- B. ASTM - American Society for Testing and Materials – *www.astm.org*

1. ASTM E 283-04 "Standard Test Method for Determining Rate of Air Leakage Through Exterior Windows, Curtain Walls, and Doors Under Specified Pressure Differences Across the Specimen"
  2. ASTM E 330-02 "Standard Test Method for Structural Performance of Exterior Windows, Doors, Skylights, and Curtain Walls by Uniform Static Air Pressure Difference"
  3. ASTM E 547-00 "Standard Test Method for Water Penetration of Exterior Windows, Skylights, Doors, and Curtain Walls by Cyclic Static Air Pressure Differential"
  4. ASTM E 2190-02 "Standard Specification for Insulating Glass Unit Performance and Evaluation"
- C. NFRC – National Fenestration Rating Council – [www.nfrc.org](http://www.nfrc.org)
1. NFRC 100-04 "Procedure for Determining Fenestration Product U Factors"
  2. NFRC 102-04 "Procedure for Measuring the Steady-State Thermal Transmittance of Fenestration Systems"
  3. NFRC 500-04 "Procedure for Determining Fenestration Product Condensation Resistance Values"
- D. IGCC – Insulating Glass Certification Council – [www.igcc.org](http://www.igcc.org)
- E. SGCC – Safety Glazing Certification Council – [www.sgcc.org](http://www.sgcc.org)
1. ANSI Z97.1-04 "American National Standard for Safety Glazing Materials used in Buildings – Safety Performance Specifications and Methods of Test"
  2. 16 CFR 1201 "Consumer Product Safety Commission Safety Standard for Architectural Glazing Materials – codified at Title 16, Part 1201 of the Code of Federal Regulations"

#### 1.04 SYSTEM DESCRIPTION

- A. AAMA Designation: H-HC40.
- B. Windows: 3-1/4" frame depth; extruded aluminum with integral structural thermal break made with glass-reinforced nylon strips installed by the window manufacturer in the frame and sash members; flange frame; exterior and interior finishes applied by the window manufacturer; frames and sash assembled by the window manufacturer.
- C. Configuration: single hung and single hung-to-single hung with continuous head and sill in master frame; bottom sash tilts in for glass cleaning.

- D. Glazing: exterior 2-part structural silicone; 7/8" insulating glass; interior foam-filled bulb gasket; glass description in paragraph 2.04; glazed by the window manufacturer.

#### 1.05 PERFORMANCE REQUIREMENTS

- A. Conformance to H-HC40 specifications in AAMA/WDMA/CSA 101/I.S.2/A440-05 when tests are performed on the prescribed 60" x 99" minimum test size with the following test results:
1. Air Infiltration: not to exceed AAMA 101 standard of maximum .3 cfm/square foot when tested per ASTM E 283-04 at a static air pressure difference of 1.6 psf.
  2. Water Penetration: no uncontrolled water leakage when tested per ASTM E 547-00 at a static air pressure difference of 10 psf.
  3. Uniform Deflection: no more than L/175 when tested per ASTM E 330-02 at a static air pressure difference of 40 psf.
  4. Uniform Structural Load: no glass breakage or permanent damage to fasteners, and maximum .3% permanent deformation of the span of any frame member when tested per ASTM E 330-02 at a static air pressure difference of 60 psf.
- B. U Value Test: thermal testing per NFRC 102-04 at the prescribed 48" x 60" test size glazed with 7/8" insulating glass made with 1/8" glass with a soft coat low E coating on the #2 surface of the exterior lite, thermoplastic butyl spacer, argon gas, and 1/8" glass with a hard coat low E coating on the #4 surface of the interior lite: Standardized Thermal Transmittance to be maximum 0.37 BTU/HR/SQ.FT/°F.
- C. U Value Simulation: thermal computer simulation per NFRC 100-04, at the prescribed 48"x 60" Non-Residential Size, glazed with 7/8" insulating glass made with 1/8" clear exterior glass lite, thermoplastic butyl spacer, argon gas, and 1/8" glass with a soft coat low E coating on the #3 surface of the interior lite: Thermal Transmittance to be maximum 0.37 BTU/HR/SQ.FT/°F.
- D. Condensation Resistance Simulation: thermal computer simulation per NFRC 500-04, at the prescribed 48"x 60" Non-Residential Size, glazed with 7/8" insulating glass made with 1/8" clear exterior glass lite, thermoplastic butyl spacer, argon gas, and 1/8" glass with a soft coat low E coating on the #3 surface of the interior lite: Condensation Resistance to be minimum 51.

#### 1.06 SUBMITTALS

- A. Shop drawings: window location chart; typical window elevations; details of assemblies, hardware, and glazing details for units glazed by window manufacturer.



- B. Product data: manufacturer's specifications and test reports from an AAMA-accredited laboratory.
- C. Samples: each specified finish for aluminum; other samples as requested.

#### 1.07 QUALITY ASSURANCE

- A. Submit for prebid approval ten days prior to bid opening a sample window representing the bid window except for color and valid test reports from an AAMA-accredited laboratory conforming to test results in Paragraph 1.07.
- B. Acceptance will be by addendum only as no verbal approvals will be allowed.
- C. Submit bid on prequalified products in prebid written addendum. Bidder must identify manufacturer and model of product on which the bid is based.
- D. Furnish a valid AAMA "Authorization for Product Certification" indicating that the windows for the project conform to AAMA/WDMA/CSA 101/1.S.2/A440-05.
- E. Furnish visible, permanent IGCC certification labels indicating conformance to ASTM E 2190-02 on insulating glass units.
- F. Furnish visible, permanent SGCC certification labels indicating conformance to ANSI Z97.1-04 and/or 16 CFR 1201 on tempered glass lites, if included on the project, and laminated glass lites, if included on the project.
- G. Manufacturer's warranties:
  1. Windows: warrant for one year against defects in material or workmanship under normal use.
  2. Insulating glass units: warrant seal for five years against visual obstruction from film formation or moisture collection between internal glass surfaces, excluding that caused by glass breakage or abuse.

Paint finish: PPG Acrynar FX™ organic finish conforming to AAMA 2604-05: warrant for ten years against chipping, peeling, cracking, chalking, or fading.

1.08 DELIVERY, STORAGE, AND HANDLING - Handle and protect windows and accessories in accordance with AAMA CW-10-04 until project completion.

## **PART 2 - PRODUCTS**

### 2.01 MANUFACTURERS

- A. TRACO NX-541 Single Hung Tilt Thermal Aluminum Window or equal

- B. Other acceptable manufacturers who have demonstrated a successful history of manufacturing for 5 years equivalent products meeting the thermal performance and be an AAMA certified product:

## 2.02 MATERIALS

- A. Aluminum extrusions: extruded by the window manufacturer from commercial quality 6063-T5 alloy; free from defects impairing strength and durability.
- B. Hardware: black zinc die cast sweep lock - one per window up to 32" window width, two on wider windows; two zinc pivot bars per sash - pivot bars engage balance shoes when sash are tilted parallel to the floor; two black nylon finger custodial tilt releases per sash – releases are spring-loaded for safety by automatically engaging the frame jamb when the sash are in their normal vertical position.
- C. Weatherstrip: secured in extruded ports; double rows on sash perimeters: pile conforming to AAMA 701/702-04 with polypropylene center fin.
- D. Balances: constant force conforming to AAMA 902-07 Class 2 with capacity to hold sash stationary and permit them to operate freely; nylon balance shoes which lock when sash are tilted to prevent sash travel.
- E. Insect screens: half; held in exterior tracks with stainless steel leaf springs; 5/16" x 1-1/2" x .045" extruded tubular aluminum frame with same finish as window; corners mitered, gusset reinforced, and crimped; 18 x 16 dark aluminum mesh; PVC spline.

## 2.03 FABRICATION

- A. Frame: head and sill coped and fastened to jambs with two stainless steel screws per corner; frame sill has two weep holes covered with weep covers for drainage; corners sealed by window manufacturer with sealant conforming to AAMA 800-07.
- B. Sash: tubular horizontal sash rails coped and fastened to double-tubular vertical sash stiles with a telescope-design joint secured with one stainless steel screw per corner; corners sealed by window manufacturer with sealant conforming to AAMA 800-07.
- C. Sash design: continuous extruded lift rail on bottom sash interior; mechanical meeting rail interlock.

## 2.04 INSULATING GLASS UNITS

### A. Materials

1. Spacer: extruded thermoplastic butyl with integrated desiccant.

2. Spacer color: black.
3. Secondary seal: silicone.
4. Airspace fill: plain argon.

B. Performance

1. Dual-seal durability: conformance to ASTM E 2190-02; visible, permanent IGCC certification label on air spacer.

C. Exterior glass lite

1. Thickness: 1/8".
2. Tint: clear.
3. Type: [tempered.
4. Coating: PPG Solarban 60 soft coat low E on #2 surface.

D. Interior glass lite

1. Thickness: 1/8".
2. Tint: clear.
3. Type: tempered.

## 2.05 FINISH ON EXTERIOR ALUMINUM EXTRUSIONS

- A. Application: on clean extrusions free from serious surface blemishes; on exposed surfaces visible when installed product's operating sash are closed.
- B. Coating: PPG Acrynar FX™ with resin containing 50% fluoropolymer; thermosetting; alternative finishes will not be acceptable.
- C. Quality standard: conforming to AAMA 2604-05, including 5 years Florida exposure and 3000 hours humidity tests.
- D. Pretreatment: five-stage; zinc chromate conversion coating.
- E. Application: electrostatic spray and oven bake by approved applicator.
- F. Coating quantity: minimum one primer coat and one color coat.

G. Dry film thickness: minimum 1.2 mils on exposed surfaces, except inside corners and channels.

H. Color: chosen from manufacturer's standards.

## 2.06 FINISH ON INTERIOR ALUMINUM EXTRUSIONS

A. Application: on clean extrusions free from serious surface blemishes; on exposed surfaces visible when installed product's operating sash are closed.

B. Coating: PPG Duracron™ with acrylic resin; thermosetting.

C. Quality standard: conforming to AAMA 2603-02, including 1 year Florida exposure and 1500 hours humidity tests.

D. Pretreatment: five-stage; zinc chromate conversion coating.

E. Application: electrostatic spray and oven bake by approved applicator.

F. Coating quantity: one color coat.

G. Dry film thickness: minimum .8 mils on exposed surfaces, except inside corners and channels.

H. Color: chosen from manufacturer's standards..

## 2.07 INSTALLATION ACCESSORIES

A. Material: extruded aluminum; nominal .062" wall; with exposed surfaces finished to match window color and finish performance; concealed fasteners; required weatherseals; designed for unrestricted expansion and contraction.

B. Exterior: extruded angle at the sill, finish and color to match exterior of window.

C. Interior: two-piece snap trim and trim clip

D. Mullions: vertical three-piece mullion with nylon strip thermal break.

## **PART 3 - EXECUTION**

3.01 PREPARATION - Prepare openings to be in tolerance, plumb, level, provide for secure anchoring, and in accordance with approved shop drawings.

### 3.02 INSTALLATION

A. Install windows in accordance with window manufacturer's recommendations and dealer's approved shop drawings with skilled craftspeople who have demonstrated a successful history of installing windows for 10 years.

- B. Provide required support and securely fasten and set windows plumb, square, and level without twist or bow.
  - C. Apply sealant per sealant manufacturer's recommendations at joints, wipe off excess, and leave exposed sealant surfaces clean and smooth.
- 3.03 ADJUSTING AND CLEANING - Adjust windows as necessary for smooth and weathertight operation, and leave windows clean and free of construction debris.

END OF SECTION

# CLIMATE ZONE MAP & CRITERIA

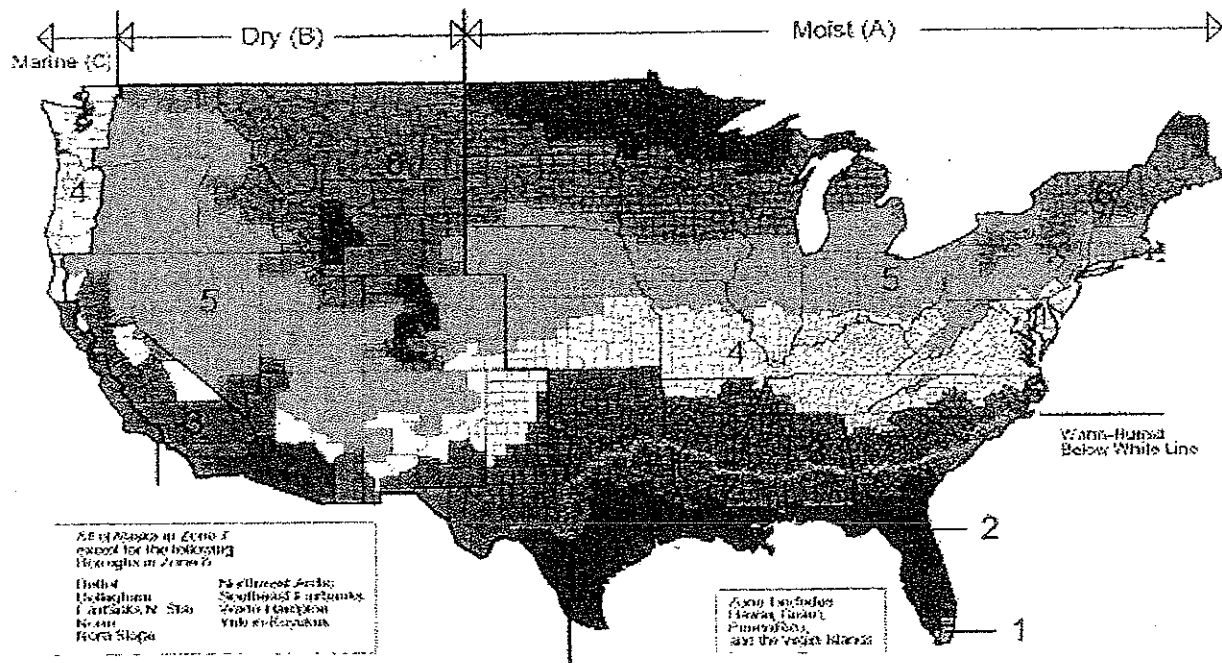

Based on NRC sizes

IECC 2009 & ASHRAE 2007 Climate Zone Criteria									
Climate Zone	Residential: Arenas		Commercial: Arenas		Curtain wall/Storefront:		Entrance door:		
	U-Value	SHGC	U-Value	SHGC	U-Value	SHGC	U-Value	SHGC	
1	1.20	0.40	1.20	0.25	1.0/1.2	0.25	1.20	0.25	
2	0.75	0.40	0.75	0.25	0.70	0.25	1.10	0.25	
3	0.65	0.40	0.65	0.25	0.60	0.25	0.90	0.25	
4	0.40	NR	0.55	0.40	0.50	0.40	0.85	0.40	
5	0.35	NR	0.55	0.40	0.45	0.40	0.80	0.40	
6	0.35	NR	0.55	0.40	0.45	0.40	0.80	0.40	
7	0.35	NR	0.45	NR	0.40	NR	0.80	NR	
8	0.35	NR	0.45	NR	0.40	NR	0.80	NR	

## ENERGY STAR® Qualification Criteria for Residential Windows, Doors, and Skylights

Windows			
Climate Zone	U-Factor <sup>1</sup>	SHGC <sup>2</sup>	
Northern	≤ 0.30	Any	Prescriptive
	≥ 0.31	≥ 0.35	Equivalent Energy Performance
	≥ 0.32	≥ 0.40	
North-Central	≤ 0.32	≤ 0.40	
South-Central	≤ 0.35	≤ 0.30	
Southern	≤ 0.60	≤ 0.27	

Doors		
Glazing Level	U-Factor <sup>1</sup>	SHGC <sup>2</sup>
Opaque	≤ 0.21	No Rating
≤ ½-Lite	≤ 0.27	≤ 0.30
> ½-Lite	≤ 0.32	≤ 0.30

Skylights		
Climate Zone	U-Factor <sup>1</sup>	SHGC <sup>2</sup>
Northern	≤ 0.55	Any
North-Central	≤ 0.55	≤ 0.40
South-Central	≤ 0.57	≤ 0.30
Southern	≤ 0.70	≤ 0.30

<sup>1</sup> Btu/h.ft<sup>2</sup>.°F

<sup>2</sup> Fraction of incident solar radiation

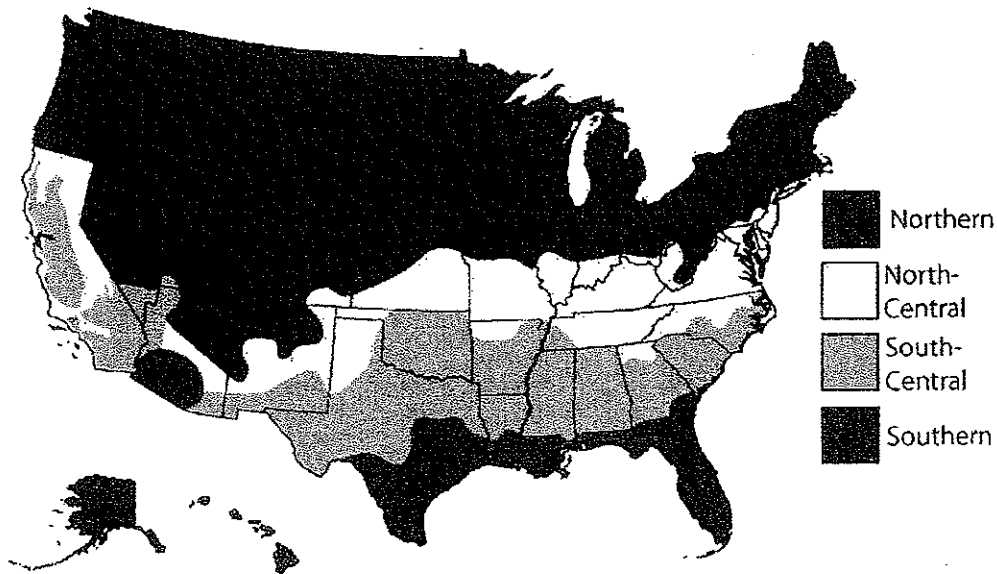

## Denmar Correctional Center Window Estimate

<u>QTY</u>	<u>WIDTH</u>	<u>HEIGHT</u>
4	23	58
12	36	51
6	36	61
4	36	65
9	36	71
16	37	62
1	38	63
33	44	63
73	48	71
6	50	62
51	50	70
2	51	60
1	63	34
1	81	55
20	84	60
55	84	72
6	147	71

300



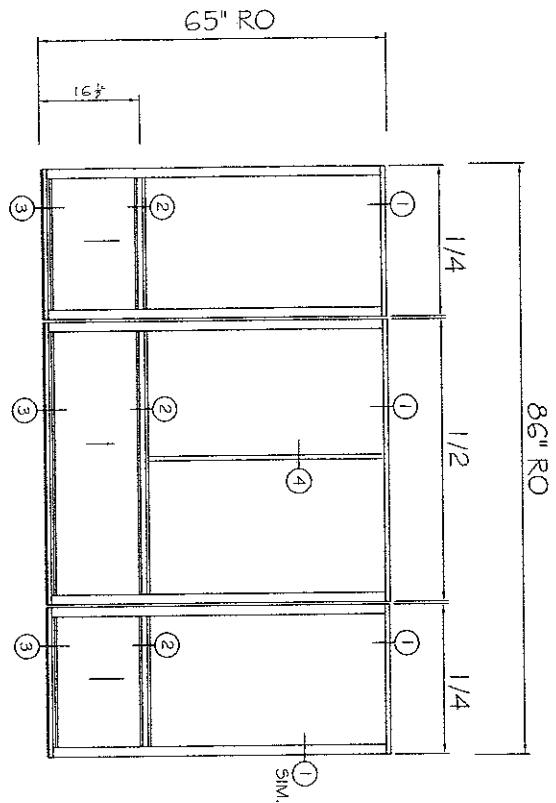

(19) OPENINGS  
NK-540

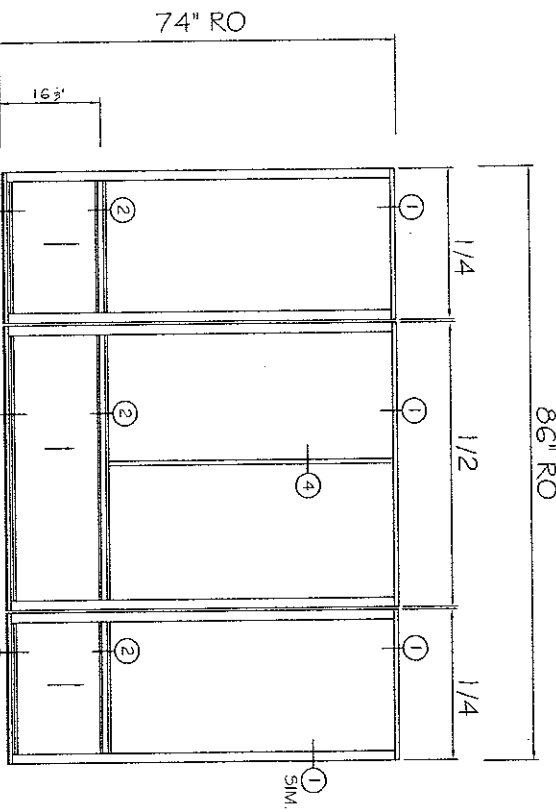

(51) OPENINGS  
NK-540

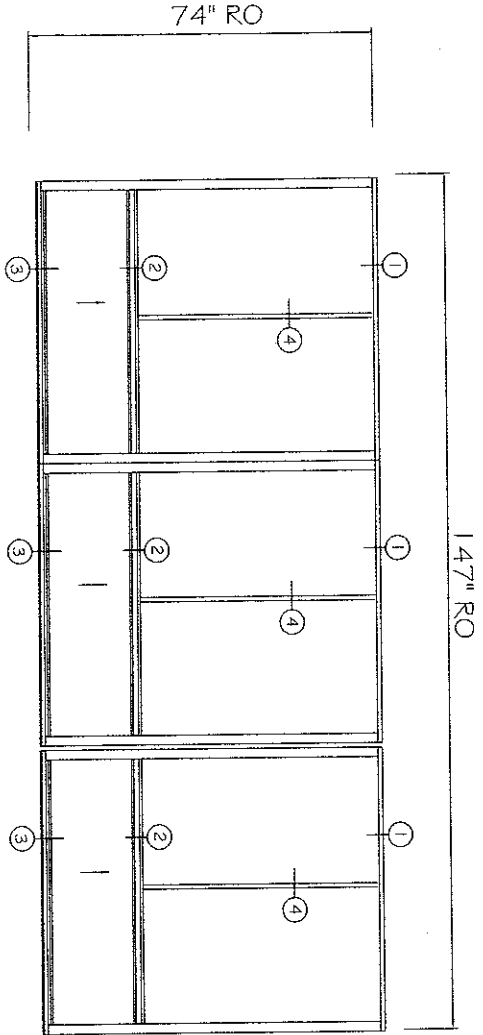

(61) OPENINGS  
NK-540

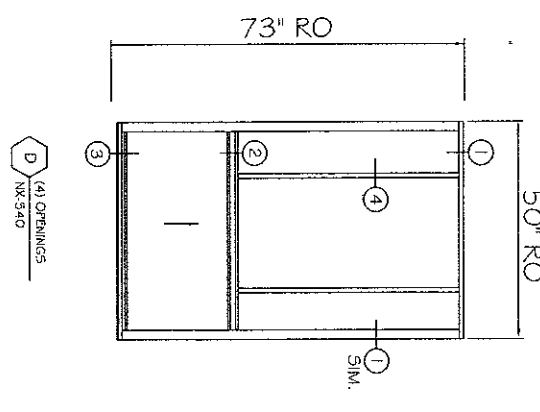
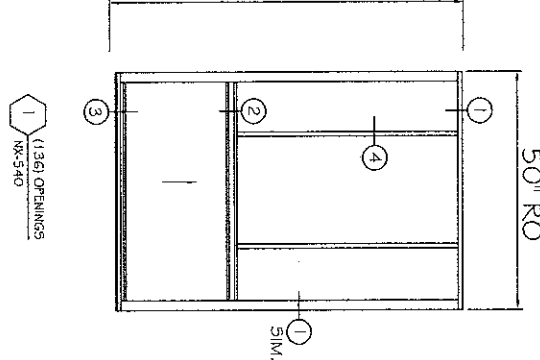
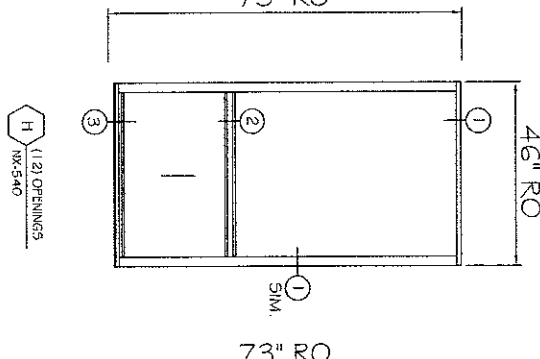
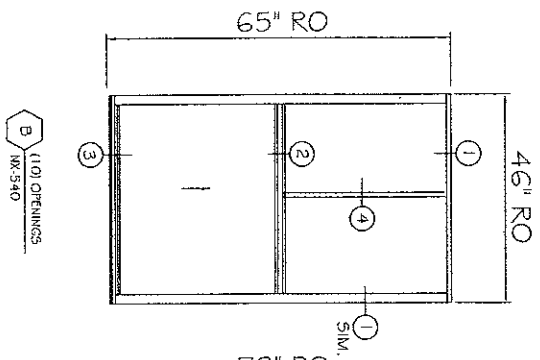
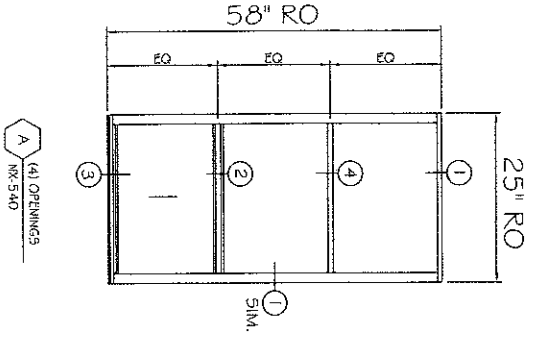
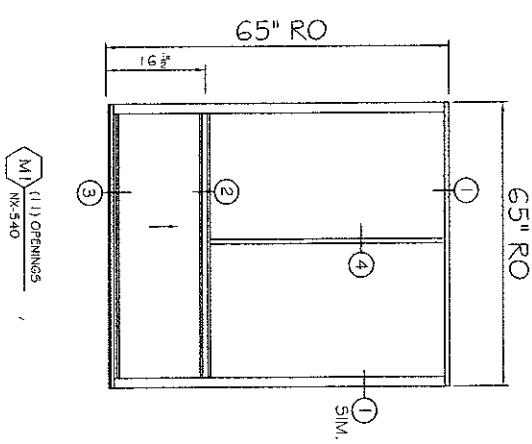
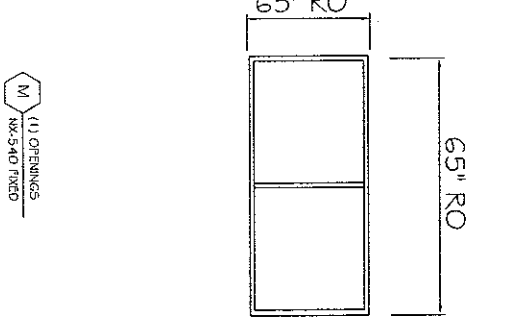
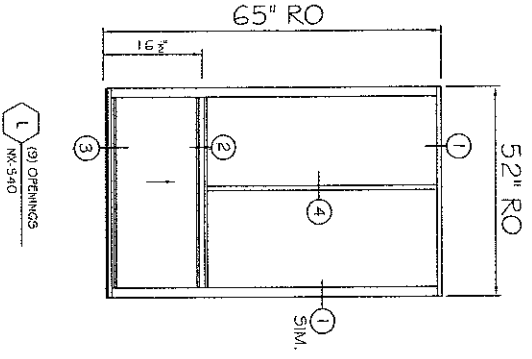
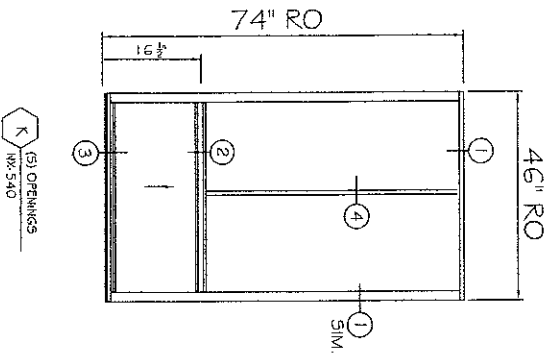
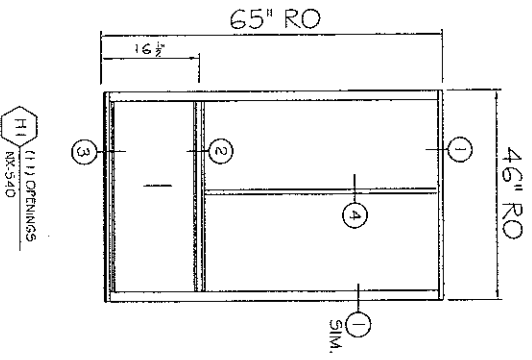

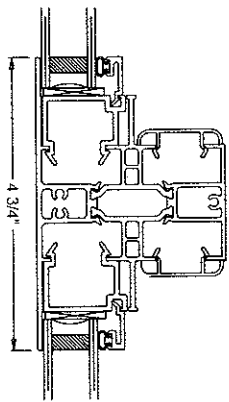
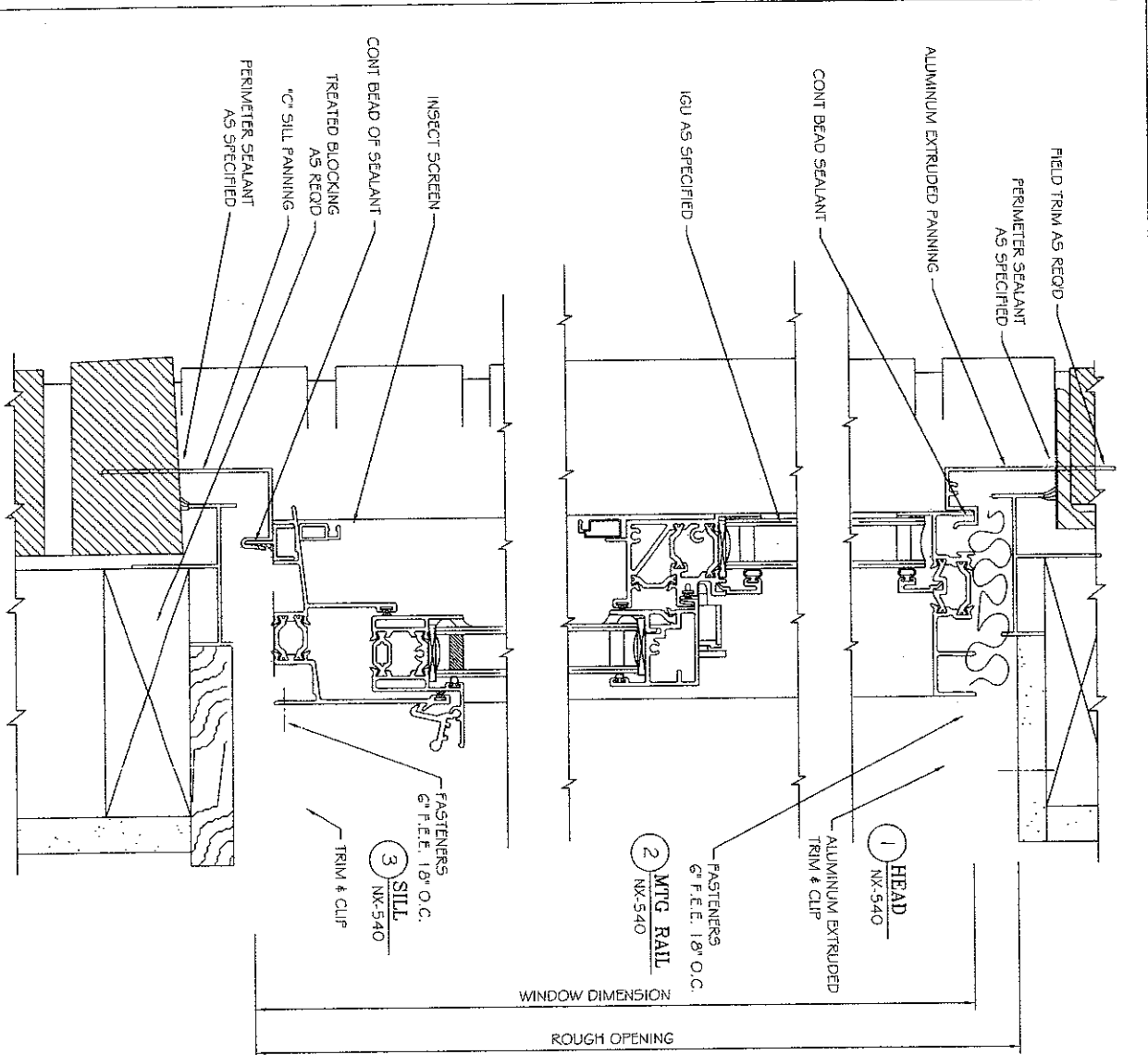



**Department of Energy**  
Washington, DC 20585

**PROJECTS FUNDED BY THE AMERICAN RECOVERY AND REINVESTMENT ACT OF 2009 AND ADMINISTERED BY THE OFFICE OF ENERGY EFFICIENCY AND RENEWABLE ENERGY NOTICE**

**EFFECTIVE DATE:** December 17, 2009

**SUBJECT:** GUIDANCE ON THE BUY AMERICAN PROVISIONS AS APPLIED TO ENERGY EFFICIENCY AND RENEWABLE ENERGY PROJECTS FUNDED BY THE AMERICAN RECOVERY AND REINVESTMENT ACT OF 2009 AND ADMINISTERED BY THE OFFICE OF ENERGY EFFICIENCY AND RENEWABLE ENERGY

**PURPOSE:** Provides guidance to financial assistance recipients regarding Buy American Recovery Act provisions under projects funded by the American Recovery and Reinvestment Act of 2009 and administered by the Office of Energy Efficiency and Renewable Energy (EERE).

As of the date of this letter the Department of Energy (DOE) has not issued any category waivers or any waivers for a particular project. If DOE issues any waivers to the Buy American Recovery Act provisions, they will be published in the *Federal Register* and otherwise made available through the DOE website and Project and Contracting Officers.

**SCOPE:** The provisions of this guidance apply to all recipients, sub-recipients and contractors working on projects using Recovery Act funding. The Buy American Recovery Act provisions only apply to projects funded under the Recovery Act for the construction, alteration, maintenance or repair of a public building or public work. The guidance below is designed to help applicants and recipients determine if their Recovery Act funded project is for the construction, alteration, maintenance or repair of a public building or public work<sup>1</sup>.

**GUIDANCE:** The Buy American provision in the American Recovery and Reinvestment Act of 2009 (section 1605 of Title XVI), provides that, subject to three listed exceptions, none of the funds appropriated or otherwise made available by the Act may be used for a project for the construction, alteration, or repair of a public building or public work unless all the iron, steel, and manufactured goods used are produced in the

<sup>1</sup> For example, if Recovery Act funded projects under the State Energy Efficient Appliance Rebate Program (SEEARP) are not for the construction, alteration, maintenance or repair of a public building or public work, the Buy American Recovery Act provisions would not apply.

Energy Efficiency and Renewable Energy Notice  
Page 2

United States. The law also requires that this prohibition be applied in a manner consistent with U.S. obligations under international agreements.

**Definitions:**

**An alteration** is defined as a limited construction project for an existing building that comprises the modification or replacement of one or a number of existing building systems or components. Alteration means remodeling, improving, extending, or making other changes to a facility, exclusive of maintenance repairs that are preventive in nature. The term includes planning, engineering, architectural work, and other similar actions.

**Public building or public work** means a public building of, and a public work of, a governmental entity (the United States; the District of Columbia; commonwealths, territories, and minor outlying islands of the United States; State and local governments; and multi-State, regional, or interstate entities which have governmental functions). These buildings and works may include, without limitation, bridges, dams, plants, highways, parkways, streets, subways, tunnels, sewers, mains, power lines, pumping stations, heavy generators, railways, airports, terminals, docks, piers, wharves, ways, lighthouses, buoys, jetties, breakwaters, levees, and canals, and the construction, alteration, maintenance, or repair of such buildings and works.

Indian tribes are also considered governmental entities for the purpose of defining "public building or public work" and are therefore subject to the Buy American provisions of the Recovery Act.

**A manufactured good** is defined as a good brought to the construction site for incorporation into the public building or work that has been processed into a specific form and shape or combined with other materials to create a material that has a different property than the individual raw materials. For example, trees cut down to a 2x4 lumber used to frame a structure would be subject to the Recovery Act Buy American provisions. Similarly, copper piping used to plumb a building would be covered. Other types of manufactured goods that are attached to or fixed to real property (fixtures) are also subject to the provision. Each item must be reviewed separately by DOE to make this determination.

There is no requirement with regard to the origin of components or subcomponents in manufactured goods used in a project, as long as the manufacturing occurs in the United States. (See 2 CFR 176.70(a)(2)(ii).

Determining whether the Buy American provisions under the Recovery Act apply to a particular project will depend on the specific details of an applicant/recipient's project. Once it is determined that the project is for the construction, alteration, maintenance or repair of a public building or public work, then all of the iron, steel and manufactured goods used in the project must be produced in the United States unless one of the three listed exceptions applies and DOE issues a waiver, or a recipient can legally avail itself of the U.S.'s obligations under international agreements.

**RECOVERY ACT EXCEPTIONS TO SECTION 1605:** The Recovery Act provides three exceptions.

1. The first exception is that applying the Buy American Recovery Act provisions would be inconsistent with the public interest.

The definition of “inconsistent with public interest” shall be interpreted by DOE on a case-by-case basis when considering waiver requests.

2. The second exception is that the iron, steel and relevant manufactured goods are not produced in the United States in sufficient and reasonably available quantities and of a satisfactory quality (“Nonavailability”).

The definitions of “sufficient and reasonably available quantities” and “of a satisfactory quality” shall be interpreted by DOE on a case-by-case basis when considering waiver requests. Applicants and recipients who would like to request a waiver of the Buy American requirements for their project based on its nonavailability, should prepare their request in accordance with the instructions provided in CFR 176.140(c), and summarized below.

3. The third exception is that the inclusion of iron, steel, and manufactured goods produced in the United States will increase the cost of the overall project by more than 25 percent (“Unreasonable Cost”).

The definitions of “sufficient and reasonably available quantities” and “of a satisfactory quality” shall be interpreted by DOE on a case-by-case basis when considering waiver requests.

Applicants and recipients who would like to request a waiver of the Buy American requirements for their project based on unreasonable cost, should prepare their request in accordance with the instructions provided in CFR 176.140(c) and (d) and 176.160(c) and (d), summarized below.

**RECOVERY ACT BUY AMERICAN REQUIREMENTS FOR INFORMATION NEEDED FROM FINANCIAL ASSISTANCE APPLICANTS/RECIPIENTS FOR WAIVER REQUESTS BASED ON UNREASONABLE COST OR NONAVAILABILITY:**

This section provides specific guidance on the unreasonable cost and nonavailability exceptions. This section does not cover requirements for the public interest exception because there are no statutory or regulatory standards for seeking or granting such a request. DOE will consider all requests for a waiver based on public interest on a case-by-case basis.

Applicants and recipients who would like to request a waiver of the Buy American requirements for their project based on unreasonable cost or nonavailability should prepare their request in accordance with the instructions below. Requests for waivers

Energy Efficiency and Renewable Energy Notice  
Page 4

based on unreasonable cost or nonavailability should be submitted to the DOE award official, who is the Project Officer assigned to the award in the Award Assistance Agreement. If a Project Officer has not been assigned at the time of the request submission, the request should be submitted to the Contracting Officer for the program under which the award is anticipated. In order to identify the name of the responsible Contracting Officer, applicants should contact the Point of Contact for the Department listed in the Funding Opportunity Announcement (FOA). The Project Officer or Contracting Officer will work with the Buy American coordinator at DOE Headquarters to determine whether to recommend approval of an application for a waiver to the Assistant Secretary of Energy for Energy Efficiency and Renewable Energy.

Certain items have already been determined to be domestically nonavailable on a class basis. They are listed at 48 C.F.R. 25.104(a). If a request includes such items, the applicant should indicate which items are on this list in the request.

**General:** This information is required for all requests for waivers of the Buy American requirements of the Recovery Act for financial assistance. [Section 1605 of the Recovery Act and 2 CFR 176.140(c) & 176.160(c)]

- Description of foreign and domestic construction materials—[See 2 CFR 176.140(c)(A) & .160(c)(A)]
- Unit of measure—[See 2 CFR 176.140(c)(B) & .160(c)(B)]
- Quantity—[See 2 CFR 176.140(c)(C) & .160(c)(C)]
- Cost—[See 2 CFR 176.140(c)(D) & .160(c)(D)]
- Price/Time of delivery or availability—[See 2 CFR 176.140(c)(E) & .160(c)(E)]
- Location of construction project—[See 2 CFR 176.140(c)(F) & .160(c)(F)]
- Name and address of proposed supplier—[See 2 CFR 176.140(c)(G) & .160(c)(G)]
- Detailed justification for the use of foreign construction materials—[See 2 CFR 176.140(c)(H) & .160(c)(H)]
- Assistance recipient made good faith effort to solicit bids for domestic construction materials/manufactured goods as demonstrated by language in requests for proposals, contracts, and communications w/prime contractor [Section 1605 of the Recovery Act]

**Unreasonable Cost:** This section lists categories of information required for waivers based on unreasonable cost of domestic construction materials or manufactured goods. The cost of domestic iron, steel, and/or manufactured goods used in the project is

Energy Efficiency and Renewable Energy Notice  
Page 5

unreasonable when the cumulative cost of such material will increase the overall cost of the project by more than 25 percent. If an applicant is requesting a waiver based on unreasonable cost of domestic construction materials or manufactured goods, the request should include the following information. [See 2 CFR 176.140(b)(3)(i) & 176.140(d)]

If an item on this list is not relevant to the request, please explain the reason for this in the request.

- Price comparison worksheet
- Relevant excerpts from the bid documents used by the contractors to complete the price comparison worksheet
- Supporting documentation indicating the contractor made a reasonable survey of the market, such as a description of the process for identifying suppliers and a list of contacted suppliers

**Nonavailability:** This section lists categories of information required for waivers based on nonavailability. Nonavailability means that the iron, steel, and/or manufactured good is not produced or manufactured in the United States in sufficient and reasonably available commercial quantities of a satisfactory quality. If an applicant is requesting a waiver based on nonavailability, the following documentation is necessary to demonstrate the available quantity and or quality of the material for which the waiver is requested [See 2 C.F.R. 176.140(b)(3)(ii)]. If an item on this list is not relevant to the request, please explain the reason for this in the request.

- Supplier information or pricing information from a reputable supplier of domestic supplies indicating availability/delivery date for materials
- Documentation of assistance recipient's efforts to find available domestic sources such as a description of the process for identifying suppliers and a list of contacted suppliers
- Project schedule (timeline)
- Relevant excerpts from project plans, qualifications, and permits indicating the required quantity and quality of construction materials
- Statement from the prime contractor confirming the non-availability of domestic construction materials for which the waiver is sought

**U.S. OBLIGATIONS UNDER INTERNATIONAL AGREEMENTS:** If a recipient can legally avail itself of the U.S.'s obligations under international agreements, it is possible that the iron, steel or manufactured good can be treated as domestic. This



Energy Efficiency and Renewable Energy Notice  
Page 6

obligation only applies to projects with an estimated value of \$7.4M or more and to projects that are not specifically excluded from the application of those agreements.

If the applicant or recipient is covered by an international agreement [Appendix to Subpart B of 2 C.F.R. 176], and, under the applicable conditions of that international agreement, the iron, steel, and/or manufactured goods are treated the same as domestic products, no waiver is needed to utilize those products.

Eligible recipients, entities covered, and relevant international agreements are listed in the Appendix to Subpart B of 2 CFR 176. Recipients should consult their own legal counsel to determine compliance with the international agreements. DOE is not authorized to determine compliance with the international agreements. Recipients should document their files with evidence of compliance with the international agreements to comply with audit requirements.

It is important to note, as the Appendix indicates, many states have exceptions to the trade agreements depending upon the items to be purchased or the state sub-entity making the purchase. Determining whether an international agreement applies is a complicated task. As such, recipients should consult their legal counsel for assistance in determining whether or not an international agreement applies in their particular case.

**LATE REQUESTS:** Late requests are defined as requests submitted after the recipient obligates the Recovery Act funds. If the recipient submits a late request for a determination regarding the inapplicability of section 1605 of the Recovery Act (Buy American) after obligating Recovery Act funds (e.g. after the signing of a construction contract), the recipient must also include an explanation of why the request was submitted at that late date. Specifically, the recipient must explain why it could not request the determination before making the obligation or why the need for such determination was not reasonably foreseeable. If the late request is based on lack of reasonably foreseeable circumstances, the recipient should provide sufficient documentation to establish the circumstance were unforeseeable.

**CONCLUSION:** As stated in the Terms and Conditions of award, recipients must comply with the Buy American Provisions of the American Recovery and Reinvestment Act. This guidance aims to clarify Buy American Recovery Act provisions. Buy American Recovery Act provisions only apply to funds used for a project for the construction, alteration, maintenance or repair of a public building or public work. Determining whether the Buy American provisions under the Recovery Act apply to a particular project will depend on the specific details of an applicant/recipient's project. Once it is determined that the project is for the construction, alteration, maintenance or repair of a public building or public work, then all of the iron, steel and manufactured goods used in the project must be produced in the United States unless one of the three listed exceptions applies and DOE issues a waiver, or a recipient can legally avail itself of the U.S.'s obligations under international agreements As of the date of this letter the

Energy Efficiency and Renewable Energy Notice  
Page 7

Department of Energy (DOE) has not issued any category waivers or any waivers for a particular project.

Applicants and recipients who have questions about the Buy American Recovery Act requirements as it applies to an award made or pending to them from a program within the DOE's Office of Energy Efficiency and Renewable Energy should submit them to this e-mail box: [buyamerican@ee.doe.gov](mailto:buyamerican@ee.doe.gov). Applicants and recipients who want to submit a request for a waiver should submit them to their Project or Contracting Officer, who will work with the Buy American coordinator at DOE Headquarters to process the waivers in a timely fashion.

Additional guidance is contained in the **Department of Energy Acquisition and Financial Assistance Guide for the American Recovery and Reinvestment Act of 2009**, located at: [http://management.energy.gov/policy\\_guidance/1672.htm](http://management.energy.gov/policy_guidance/1672.htm)



Cathy Zoi  
Assistant Secretary for Energy Efficiency and Renewable Energy  
U.S. Department of Energy

## Denmar Correctional Center

The West Virginia Division of Corrections received funding through the American Recovery and Reinvestment Act or stimulus to replace all 300 windows with 428 openings at the Denmar Correctional Center with energy efficient materials to save on energy use. We have identified Traco NX540 with SB60 #2 or equal as the one meeting our needs

The minimum requirements that shall be bid on are as follows:

	Meets Spec	
	<u>Yes</u>	<u>No</u>
Remove windows in three hundred existing openings, (old frame at perimeter to remain at singles, will be covered by new window systems).	X	
Demolition of existing assembly by licensed abatement contractor.	<u>N/A Per Addendum #1</u>	
Air monitoring and proper disposal is included.	<u>N/A Per Addendum #1</u>	
New windows shall be NX540 single hung "HC50" per AAMA 101-97 requirements OR EQUAL. Sash stops shall be extended to limit sash travel to a 10" clear opening. Sash stops to be held in place with tamper resistant screws, 2-screws each side.	X	
Glazing shall be double strength tempered insulated units with Low "E" on the third surface.	X	
Finish shall be 10-year AAMA Acrynar FX by PPG.	X	
All labor shall be at Prevailing Wage rate.	X	
Sealant at exterior of windows shall be Dow Corning 790 Silicone.	X	
"U" value as required per <a href="http://www.energycode.gov">www.energycode.gov</a> for WV Pocahontas County Code 13. There is a total of 8018 sq. ft. of window area.	X	
All proposed materials must comply with the made in America provision	X	

**COR61433 - Bid Form REVISED per Addm No. 1**

Description	Estimated Order Qty.	Unit Price	Extended Total
Demolition of existing assemblies	378	\$ 204.00	\$77,112.00
Provide and install 378 windows in 306 openings	378	\$1,163.00	\$439,614.00
		<b>Grand Total</b>	<b>\$516,726.00</b>

**Bidder / Vendor Information:**

Name: City Window Systems, LLC

Address: Rt. 2 Box 285  
Clarksburg, WV 26301

Phone#: 304.623.2573

Email Address: rhenderson@wvds1.net

**Contract Coordinator Information:**

Name: Ron Henderson, City Window Systems, LLC

Address: Rt. 2 Box 285  
Clarksburg, WV 26301

Phone#: 304.623.2573

Email Address: rhenderson@wvds1.net

Purchasing Division Surplus Property Unit

### SURPLUS PROPERTY RETIREMENT FORM

(For use when retiring equipment with an acquisition cost of \$1,000 or less and not on the WVFIMS Fixed Assets System)

Retirement Number DEN 8042010  
(To Be Assigned by the Agency)

Submit Completed Form to:  
Purchasing Division  
Administrative Services Section  
Surplus Property Unit  
2700 Charles Avenue  
Durbar, WV 26064

**Recommended Disposition Method**  
(CHECK ONLY ONE)

Agency Will Deliver to Property (1)  
 Request Pickup by Surplus Property (2)  
 Request Sale on Site (3)  
 Sell for Scrap Value (4)  
 Send to Landfill (5)

[Use one disposition method per form]

Department Name: MAPS Org #: 0603  
Object Code:  
Department Address: 1409 GREENBRIER, ST., CHAS., WV 26311  
Division Name and Address: WV DIVISION OF CORRECTIONS  
Specific Location of Equipment: DENMAR CORRECTIONAL CENTER  
Agency Inventory Coordinator: F. LEE HARVEY  
Telephone # ( ): 304-558-8045 FAX # ( ): 304-558-8048

INFORMATION ON THIS FORM MUST BE TYPED OR CLEARLY PRINTED WHEN SUBMITTED TO THE SURPLUS PROPERTY UNIT, PURCHASING DIVISION

Inventory Tag #	No. of Units	Description	Original Acq Cost	Acquisition Date		PO Number	PO Date	Physical Condition, Age, and Estimate Cost of Repairs
				Model	Serial Number			
	378	ONE LOT OF WINDOWS, STEEL, ALUMINUM & GLASS	UNKNOWN	UNKNOWN	UNKNOWN	UNKNOWN	UNKNOWN	OUTLIVED USEFULL LIFE WORN BEYOND ECONOMICAL REPAIR
								TO BE REPLACED THROUGH FEDERAL STIMULUS GRANT CONTRACTOR IS
								RESPONSIBLE FOR DISPOSAL OF OLD WINDOWS

The items listed on this form are not part of my agency's WVFIMS Fixed Asset Inventory

Agency Authorized Signature: [Signature] Title: ACCT/AUD II  
I do hereby certify that I have this day witnessed disposal of equipment listed above in the manner approved  
Agency Signature: \_\_\_\_\_ Title: \_\_\_\_\_ Date: \_\_\_\_\_  
This retirement document has been completed by the Surplus Property Unit.  
Signature: \_\_\_\_\_ Title: \_\_\_\_\_ Date: \_\_\_\_\_

Recommended Disposition Method  
 Approved  
 Disapproved  
If Disapproved, Preferred Disposition Method is: See above (see above)  
Manager of Surplus Property Unit: [Signature] Date: 8-5-10

Distribution:  
 Agency send original and one (1) copy to the Surplus Property Unit.  
 Agency retain copy for their files.

# CONTRACTOR LICENSE

Authorized by the

**West Virginia Contractor Licensing Board**

**Number:** WV038038

**Classification:**

GENERAL BUILDING

CITY WINDOW SYSTEMS LLC  
DBA CITY WINDOW SYSTEMS LLC  
RT 2 BOX 285  
CLARKSBURG, WV 26301

**Date Issued**

DECEMBER 06, 2009

**Expiration Date**

DECEMBER 06, 2010



Authorized Company Signature



Chair, West Virginia Contractor  
Licensing Board

**WEST VIRGINIA  
CONTRACTOR  
LICENSING  
BOARD**

This license, or a copy thereof, must be posted in a conspicuous place at every construction site where work is being performed. This license number must appear in all advertisements, on all bid submissions and on all fully executed and binding contracts. This license cannot be assigned or transferred by licensee. Issued under provisions of West Virginia Code, Chapter 21, Article 11.

**2009**

**WEST VIRGINIA  
STATE TAX DEPARTMENT**

**2011**

**BUSINESS REGISTRATION  
CERTIFICATE**

ISSUED TO:  
**CITY WINDOW SYSTEMS LLC  
RR 2 BOX 285  
CLARKSBURG, WV 26301-9637**

**BUSINESS REGISTRATION ACCOUNT NUMBER: 1006-7547**

This certificate is issued for the registration period beginning: **July 1, 2009**

This certificate is valid until: **June 30, 2011**

*This business registration certificate is issued by  
the West Virginia State Tax Commissioner  
in accordance with Chapter 11, Article 12 of the West Virginia Code.*

*The person or organization identified on this certificate is registered  
to conduct business in the State of West Virginia at the location above.*

**This certificate is not transferrable and must be displayed at the location for which issued.**

**ENGAGING IN BUSINESS WITHOUT CONSPICUOUSLY POSTING A WEST VIRGINIA BUSINESS  
REGISTRATION CERTIFICATE IN THE PLACE OF BUSINESS IS A CRIME AND MAY SUBJECT YOU  
TO FINES PER W. VA. CODE § 11-9.**

**TRAVELING/STREET VENDORS: Must carry a copy of this certificate in every vehicle operated by them.  
CONTRACTORS, DRILLING OPERATORS, TIMBER/LOGGING OPERATIONS: Must have a copy of  
this certificate displayed at every job site within West Virginia.**

Agency \_\_\_\_\_  
REQ.P.O# \_\_\_\_\_

**BID BOND**

KNOW ALL MEN BY THESE PRESENTS, That we, the undersigned, \_\_\_\_\_  
of \_\_\_\_\_, \_\_\_\_\_, as Principal, and \_\_\_\_\_  
of \_\_\_\_\_, \_\_\_\_\_, a corporation organized and existing under the laws of the State of \_\_\_\_\_  
with its principal office in the City of \_\_\_\_\_, as Surety, are held and firmly bound unto the State  
of West Virginia, as Obligee, in the penal sum of \_\_\_\_\_ (\$ \_\_\_\_\_) for the payment of which,  
well and truly to be made, we jointly and severally bind ourselves, our heirs, administrators, executors, successors and assigns.

The Condition of the above obligation is such that whereas the Principal has submitted to the Purchasing Section of the  
Department of Administration a certain bid or proposal, attached hereto and made a part hereof, to enter into a contract in writing for

\_\_\_\_\_  
\_\_\_\_\_  
\_\_\_\_\_

**NOW THEREFORE,**

(a) If said bid shall be rejected, or

(b) If said bid shall be accepted and the Principal shall enter into a contract in accordance with the bid or proposal attached

hereto and shall furnish any other bonds and insurance required by the bid or proposal, and shall in all other respects perform the  
agreement created by the acceptance of said bid, then this obligation shall be null and void, otherwise this obligation shall remain in full  
force and effect. It is expressly understood and agreed that the liability of the Surety for any and all claims hereunder shall, in no event,  
exceed the penal amount of this obligation as herein stated.

The Surety, for the value received, hereby stipulates and agrees that the obligations of said Surety and its bond shall be in no  
way impaired or affected by any extension of the time within which the Obligee may accept such bid, and said Surety does hereby  
waive notice of any such extension.

IN WITNESS WHEREOF, Principal and Surety have hereunto set their hands and seals, and such of them as are corporations  
have caused their corporate seals to be affixed hereunto and these presents to be signed by their proper officers, this

\_\_\_\_\_ day of \_\_\_\_\_, 20\_\_\_\_.

Principal Corporate Seal

\_\_\_\_\_  
(Name of Principal)

By \_\_\_\_\_

(Must be President or  
Vice President)

\_\_\_\_\_  
(Title)

Surety Corporate Seal

\_\_\_\_\_  
(Name of Surety)

\_\_\_\_\_  
Attorney-in-Fact

**IMPORTANT - Surety executing bonds must be licensed in West Virginia to transact surety insurance. Raised corporate seals  
must be affixed, a power of attorney must be attached.**



BID BOND PREPARATION INSTRUCTIONS

AGENCY \_\_\_\_\_ (A)  
 RFQ/RFP# \_\_\_\_\_ (B)

**Bid Bond**

KNOW ALL MEN BY THESE PRESENTS, That we, the undersigned,  
 \_\_\_\_\_ (C) of \_\_\_\_\_ (D), \_\_\_\_\_ (E),  
 as Principal, and \_\_\_\_\_ (F) of \_\_\_\_\_ (G),  
 \_\_\_\_\_ (H), a corporation organized and existing under the laws  
 of the State of \_\_\_\_\_ (I) with its principal office in the City of  
 \_\_\_\_\_ (J), as Surety, are held and firmly bound unto The State  
 of West Virginia, as Obligee, in the penal sum of \_\_\_\_\_ (K)  
 (\$ \_\_\_\_\_ (L)) for the payment of which, well and truly to be made,  
 we jointly and severally bind ourselves, our heirs, administrators, executors,  
 successors and assigns.

The Condition of the above obligation is such that whereas the Principal  
 has submitted to the Purchasing Section of the Department of Administration  
 a certain bid or proposal, attached hereto and made a part hereof to enter into a  
 contract in writing for \_\_\_\_\_ (M)

NOW THEREFORE.

(a) If said bid shall be rejected, or  
 (b) If said bid shall be accepted and the Principal shall enter into a  
 contract in accordance with the bid or proposal attached hereto and shall furnish  
 any other bonds and insurance required by the bid or proposal, and shall in all  
 other respects perform the agreement created by the acceptance of said bid then  
 this obligation shall be null and void, otherwise this obligation shall remain in full  
 force and effect. It is expressly understood and agreed that the liability of the  
 Surety for any and all claims hereunder shall, in no event, exceed the penal  
 amount of this obligation as herein stated

The Surety for value received, hereby stipulates and agrees that the  
 obligations of said Surety and its bond shall be in no way impaired or affected by  
 any extension of time within which the Obligee may accept such bid; and said  
 Surety does hereby waive notice of any such extension.

IN WITNESS WHEREOF, Principal and Surety have hereunto set their  
 hands and seals, and such of them as are corporations have caused their corporate  
 seals to be affixed hereto and these presents to be signed by their proper officers,  
 this \_\_\_\_\_ (N) day of \_\_\_\_\_ (O), 20 \_\_\_\_\_ (P).

Principal Corporate Seal

(R)

(U)  
 Surety Corporate Seal

\_\_\_\_\_  
 (Name of Principal)  
 By \_\_\_\_\_  
 (Must be President or  
 Vice President)  
 \_\_\_\_\_  
 Title  
 \_\_\_\_\_  
 (Name of Surety)

\_\_\_\_\_  
 Attorney-in-Fact

- (A) WV State Agency  
 (Stated on Page 1 "Spending Unit")  
 Request for Quotation Number (upper  
 right corner of page #1)
  - (C) Your Company Name
  - (D) City, Location of your Company
  - (E) State, Location of your Company
  - (F) Surety Corporate Name
  - (G) City, Location of Surety
  - (H) State, Location of Surety
  - (I) State of Surety Incorporation
  - (J) City of Surety Incorporation
  - (K) Minimum amount of acceptable bid  
 bond is 5% of total bid. You may state  
 "5% of bid" or a specific amount on  
 this line in words.
  - (L) Amount of bond in figures
  - (M) Brief Description of scope of work
  - (N) Day of the month
  - (O) Month
  - (P) Year
  - (Q) Name of Corporation
  - (R) Raised Corporate Seal of Principal
  - (S) Signature of President or Vice  
 President
  - (T) Title of person signing
  - (U) Raised Corporate Seal of Surety
  - (V) Corporate Name of Surety
  - (W) Signature of Attorney in Fact of the  
 Surety
- NOTE: Dated, Power of Attorney with Raised  
 Surety Seal must accompany this bid  
 bond.

IMPORTANT – Surety executing bonds must be licensed in West Virginia to  
 transact surety insurance. Raised Corporate Seals must be affixed and a Power of  
 Attorney must be attached.

BID BOND

KNOW ALL MEN BY THESE PRESENTS, That we, the undersigned, City Window Systems, LLC  
of Clarksburg, WV, as Principal, and Great American Insurance Company  
of Cincinnati, OH, a corporation organized and existing under the laws of the State of  
OH with its principal office in the City of Cincinnati, as Surety, are held and firmly bound unto the State  
of West Virginia, as Obligee, in the penal sum of Five Percent of Amount Bid (\$ 5%) for the payment of which,  
well and truly to be made, we jointly and severally bind ourselves, our heirs, administrators, executors, successors and assigns.

The Condition of the above obligation is such that whereas the Principal has submitted to the Purchasing Section of the  
Department of Administration a certain bid or proposal, attached hereto and made a part hereof, to enter into a contract in writing for  
Window replacement at Denmar Correctional Center, Hillsboro, WV

NOW THEREFORE,

(a) If said bid shall be rejected, or  
(b) If said bid shall be accepted and the Principal shall enter into a contract in accordance with the bid or proposal attached  
hereto and shall furnish any other bonds and insurance required by the bid or proposal, and shall in all other respects perform the  
agreement created by the acceptance of said bid, then this obligation shall be null and void, otherwise this obligation shall remain in full  
force and effect. It is expressly understood and agreed that the liability of the Surety for any and all claims hereunder shall, in no event,  
exceed the penal amount of this obligation as herein stated.

The Surety, for the value received, hereby stipulates and agrees that the obligations of said Surety and its bond shall be in no  
way impaired or affected by any extension of the time within which the Obligee may accept such bid, and said Surety does hereby  
waive notice of any such extension.

IN WITNESS WHEREOF, Principal and Surety have hereunto set their hands and seals, and such of them as are corporations  
have caused their corporate seals to be affixed hereunto and these presents to be signed by their proper officers, this  
12th day of August, 2010

Principal Corporate Seal

City Window Systems, LLC  
(Name of Principal)  
By [Signature]  
(Must be President or  
Vice President)  
Managing Member  
(Title)

Surety Corporate Seal

Great American Insurance Company  
(Name of Surety)  
By: [Signature]  
Douglas P. Taylor, Licensed WV Resident Agent Attorney-in-Fact

**GREAT AMERICAN INSURANCE COMPANY®**

Administrative Office: 580 WALNUT STREET • CINCINNATI, OHIO 45202 • 513-369-5000 • FAX 513-723-2740

The number of persons authorized by  
this power of attorney is not more than SIX

No. 0 18479

**POWER OF ATTORNEY**

**KNOW ALL MEN BY THESE PRESENTS:** That the GREAT AMERICAN INSURANCE COMPANY, a corporation organized and existing under and by virtue of the laws of the State of Ohio, does hereby nominate, constitute and appoint the person or persons named below, each individually if more than one is named, its true and lawful attorney-in-fact, for it and in its name, place and stead to execute on behalf of the said Company, as surety, any and all bonds, undertakings and contracts of suretyship, or other written obligations in the nature thereof; provided that the liability of the said Company on any such bond, undertaking or contract of suretyship executed under this authority shall not exceed the limit stated below.

	Name	Address	Limit of Power
ANDREW K. TEETER	KIMBERLY L. MILES	ALL OF	ALL
DOUGLAS P. TAYLOR	DONNA J. PRICE	CHARLESTON, WEST VIRGINIA	\$75,000,000.
BRADLEY P. BOBERSKY	PAMELA V. LANHAM		

This Power of Attorney revokes all previous powers issued on behalf of the attorney(s)-in-fact named above.

IN WITNESS WHEREOF the GREAT AMERICAN INSURANCE COMPANY has caused these presents to be signed and attested by its appropriate officers and its corporate seal hereunto affixed this 16TH day of APRIL, 2009  
Attest GREAT AMERICAN INSURANCE COMPANY

STATE OF OHIO, COUNTY OF HAMILTON - ss:

DAVID C. KITCHIN (513-412-4602)

On this 16TH day of APRIL 2009, before me personally appeared DAVID C. KITCHIN, to me known, being duly sworn, deposes and says that he resides in Cincinnati, Ohio, that he is a Divisional Senior Vice President of the Bond Division of Great American Insurance Company, the Company described in and which executed the above instrument; that he knows the seal of the said Company; that the seal affixed to the said instrument is such corporate seal; that it was so affixed by authority of his office under the By-Laws of said Company, and that he signed his name thereto by like authority.

This Power of Attorney is granted by authority of the following resolutions adopted by the Board of Directors of Great American Insurance Company by unanimous written consent dated June 9, 2008.

*RESOLVED: That the Divisional President, the several Divisional Senior Vice Presidents, Divisional Vice Presidents and Divisional Assistant Vice Presidents, or any one of them, be and hereby is authorized, from time to time, to appoint one or more Attorneys-in-Fact to execute on behalf of the Company, as surety, any and all bonds, undertakings and contracts of suretyship, or other written obligations in the nature thereof; to prescribe their respective duties and the respective limits of their authority; and to revoke any such appointment at any time.*

*RESOLVED FURTHER: That the Company seal and the signature of any of the aforesaid officers and any Secretary or Assistant Secretary of the Company may be affixed by facsimile to any power of attorney or certificate of either given for the execution of any bond, undertaking, contract of suretyship, or other written obligation in the nature thereof, such signature and seal when so used being hereby adopted by the Company as the original signature of such officer and the original seal of the Company, to be valid and binding upon the Company with the same force and effect as though manually affixed.*

**CERTIFICATION**

I, STEPHEN C. BERAHA, Assistant Secretary of Great American Insurance Company, do hereby certify that the foregoing Power of Attorney and the Resolutions of the Board of Directors of June 9, 2008 have not been revoked and are now in full force and effect.

Signed and sealed this 12th day of August, 2010



State of West Virginia  
DRUG FREE WORKPLACE CONFORMANCE AFFIDAVIT  
West Virginia Code §21-1D-5

STATE OF West Virginia

COUNTY OF Harrison, TO-WIT:

I, Ron Henderson, after being first duly sworn, depose and state as follows:

- 1. I am an employee of City Construction Company, Inc.; and,  
(Company Name)
- 2. I do hereby attest that City Window Systems, LLC  
(Company Name)

maintains a valid written drug free workplace policy and that such policy is in compliance with **West Virginia Code §21-1D-5**.

The above statements are sworn to under the penalty of perjury.

City Construction Company, Inc.  
(Company Name)

By: [Signature]

Title: Sr. Vice President

Date: August 12, 2010

Taken, subscribed and sworn to before me this 12th day of August 2010.

By Commission expires May 21, 2017

(Seal)



OFFICIAL SEAL  
STATE OF WEST VIRGINIA  
NOTARY PUBLIC  
DEBRA D. CLEVENGER  
CITY WINDOW SYSTEMS, LLC  
RT. 2, BOX 285  
CLARKSBURG, WV 26301  
My commission expires May 21, 2017

[Signature]  
(Notary Public)

**THIS AFFIDAVIT MUST BE SUBMITTED WITH THE BID IN ORDER TO COMPLY WITH WV CODE PROVISIONS. FAILURE TO INCLUDE THE AFFIDAVIT WITH THE BID SHALL RESULT IN DISQUALIFICATION OF THE BID.**

STATE OF WEST VIRGINIA  
Purchasing Division

**PURCHASING AFFIDAVIT**

**West Virginia Code §5A-3-10a states:** No contract or renewal of any contract may be awarded by the state or any of its political subdivisions to any vendor or prospective vendor when the vendor or prospective vendor or a related party to the vendor or prospective vendor is a debtor and the debt owed is an amount greater than one thousand dollars in the aggregate.

**DEFINITIONS:**

"Debt" means any assessment, premium, penalty, fine, tax or other amount of money owed to the state or any of its political subdivisions because of a judgment, fine, permit violation, license assessment, defaulted workers' compensation premium, penalty or other assessment presently delinquent or due and required to be paid to the state or any of its political subdivisions, including any interest or additional penalties accrued thereon.

"Debtor" means any individual, corporation, partnership, association, limited liability company or any other form or business association owing a debt to the state or any of its political subdivisions. "Political subdivision" means any county commission; municipality; county board of education; any instrumentality established by a county or municipality; any separate corporation or instrumentality established by one or more counties or municipalities, as permitted by law; or any public body charged by law with the performance of a government function or whose jurisdiction is coextensive with one or more counties or municipalities. "Related party" means a party, whether an individual, corporation, partnership, association, limited liability company or any other form or business association or other entity whatsoever, related to any vendor by blood, marriage, ownership or contract through which the party has a relationship of ownership or other interest with the vendor so that the party will actually or by effect receive or control a portion of the benefit, profit or other consideration from performance of a vendor contract with the party receiving an amount that meets or exceed five percent of the total contract amount.

**EXCEPTION:** The prohibition of this section does not apply where a vendor has contested any tax administered pursuant to chapter eleven of this code, workers' compensation premium, permit fee or environmental fee or assessment and the matter has not become final or where the vendor has entered into a payment plan or agreement and the vendor is not in default of any of the provisions of such plan or agreement.

Under penalty of law for false swearing (*West Virginia Code §61-5-3*), it is hereby certified that the vendor affirms and acknowledges the information in this affidavit and is in compliance with the requirements as stated.

**WITNESS THE FOLLOWING SIGNATURE**

Vendor's Name: City Window Systems, LLC

Authorized Signature: *[Signature]* Date: August 12, 2010

State of West Virginia

County of Harrison, to-wit:

Taken, subscribed, and sworn to before me this 12 day of August, 2010

My Commission expires May 21, 2017, 20    .

**AFFIX SEAL HERE**

NOTARY PUBLIC *[Signature]*

