



State of West Virginia
 Department of Administration
 Purchasing Division
 2019 Washington Street East
 Post Office Box 50130
 Charleston, WV 25305-0130

Request for Quotation

RFQ NUMBER
7011EC15

PAGE
1

ADDRESS CORRESPONDENCE TO ATTENTION OF
 BUYER 33
 304-558-2402

VENDOR

RFQ COPY
 TYPE NAME/ADDRESS HERE
LH Jones Equipment Co
1825 East L. Core Rd.
Morgantown, WV 26505

SHIP TO

DIVISION OF HIGHWAYS
 EQUIPMENT DIVISION
 ROUTE 33
 BRUSHY FORK ROAD
 BUCKHANNON, WV
 26201 304-472-1750

DATE PRINTED	TERMS OF SALE	SHIP VIA	FOB	FREIGHT TERMS
12/29/2010	<i>Net 30 Days</i>	<i>Motor Freight</i>	<i>Buckhannon, WV</i>	<i>No charge</i>
BID OPENING DATE: 02/24/2011		BID OPENING TIME 01:30PM		

LINE	QUANTITY	UOP	CAT NO.	ITEM NUMBER	UNIT PRICE	AMOUNT
0001	1	EA		570-64	14,168.00	14,168.00
	9 CUBIC YARD	ABRASIVE		AND CHEMICAL SPREADER		
<p>REQUEST FOR QUOTATION (RFQ) OPEN END CONTRACT</p> <p>THE WEST VIRGINIA STATE PURCHASING DIVISION FOR THE AGENCY, THE WEST VIRGINIA DIVISION OF HIGHWAYS, IS SOLICITING BIDS FOR AN OPEN END CONTRACT TO PROVIDE A 9 CUBIC YARD STAINLESS STEEL DEMOUNTABLE ABRASIVE AND CHEMICAL SPREADER HYDRAULIC PER THE ATTACHED SPECIFICATIONS.</p> <p>TECHNICAL QUESTIONS CONCERNING THIS SOLICITATION MUST BE SUBMITTED IN WRITING TO SHERI SLONE IN THE WEST VIRGINIA STATE PURCHASING DIVISION VIA MAIL AT THE ADDRESS SHOWN IN THE BODY OF THIS RFQ, VIA FAX AT 304-558-2596, OR VIA EMAIL AT SHERI.D.SLONE@WV.GOV. DEADLINE FOR ALL TECHNICAL QUESTIONS IS 01/19/2011 AT THE CLOSE OF BUSINESS. ANY TECHNICAL QUESTIONS RECEIVED WILL BE ANSWERED BY FORMAL ADDENDUM TO BE ISSUED BY THE PURCHASING DIVISION AFTER THE DEADLINE HAS LAPSED.</p> <p>MANDATORY PRE-BID A MANDATORY PRE-BID WILL BE HELD ON TUESDAY, 02/01/2011 AT 11 AM IN BRUSHY FORK RD IN BUCKHANNON, WV 26201. ALL INTERESTED PARTIES ARE REQUIRED TO ATTEND THIS MEETING</p>						

RECEIVED

2011 FEB 23 A 10:03

PURCHASING DIVISION
 STATE OF WV

SEE REVERSE SIDE FOR TERMS AND CONDITIONS

SIGNATURE <i>[Signature]</i>	TELEPHONE 304 292 1307	DATE 2/22/11
TITLE C.U.O.	FERN 55-055-865	ADDRESS CHANGES TO BE NOTED ABOVE

WHEN RESPONDING TO RFQ, INSERT NAME AND ADDRESS IN SPACE ABOVE LABELED 'VENDOR'

GENERAL TERMS & CONDITIONS REQUEST FOR QUOTATION (RFQ) AND REQUEST FOR PROPOSAL (RFP)

1. Awards will be made in the best interest of the State of West Virginia.
2. The State may accept or reject in part, or in whole, any bid.
3. Prior to any award, the apparent successful vendor must be properly registered with the Purchasing Division and have paid the required \$125 fee.
4. All services performed or goods delivered under State Purchase Order/Contracts are to be continued for the term of the Purchase Order/Contracts, contingent upon funds being appropriated by the Legislature or otherwise being made available. In the event funds are not appropriated or otherwise available for these services or goods this Purchase Order/Contract becomes void and of no effect after June 30.
5. Payment may only be made after the delivery and acceptance of goods or services.
6. Interest may be paid for late payment in accordance with the *West Virginia Code*.
7. Vendor preference will be granted upon written request in accordance with the *West Virginia Code*.
8. The State of West Virginia is exempt from federal and state taxes and will not pay or reimburse such taxes.
9. The Director of Purchasing may cancel any Purchase Order/Contract upon 30 days written notice to the seller.
10. The laws of the State of West Virginia and the *Legislative Rules* of the Purchasing Division shall govern the purchasing process.
11. Any reference to automatic renewal is hereby deleted. The Contract may be renewed only upon mutual written agreement of the parties.
12. **BANKRUPTCY:** In the event the vendor/contractor files for bankruptcy protection, the State may deem this contract null and void, and terminate such contract without further order.
13. **HIPAA BUSINESS ASSOCIATE ADDENDUM:** The West Virginia State Government HIPAA Business Associate Addendum (BAA), approved by the Attorney General, is available online at www.state.wv.us/admin/purchase/vrc/hipaa.htm and is hereby made part of the agreement. Provided that the Agency meets the definition of a Cover Entity (45 CFR §160.103) and will be disclosing Protected Health Information (45 CFR §160.103) to the vendor.
14. **CONFIDENTIALITY:** The vendor agrees that he or she will not disclose to anyone, directly or indirectly, any such personally identifiable information or other confidential information gained from the agency, unless the individual who is the subject of the information consents to the disclosure in writing or the disclosure is made pursuant to the agency's policies, procedures, and rules. Vendor further agrees to comply with the Confidentiality Policies and Information Security Accountability Requirements, set forth in <http://www.state.wv.us/admin/purchase/privacy/noticeConfidentiality.pdf>.
15. **LICENSING:** Vendors must be licensed and in good standing in accordance with any and all state and local laws and requirements by any state or local agency of West Virginia, including, but not limited to, the West Virginia Secretary of State's Office, the West Virginia Tax Department, and the West Virginia Insurance Commission. The vendor must provide all necessary releases to obtain information to enable the director or spending unit to verify that the vendor is licensed and in good standing with the above entities.
16. **ANTITRUST:** In submitting a bid to any agency for the State of West Virginia, the bidder offers and agrees that if the bid is accepted the bidder will convey, sell, assign or transfer to the State of West Virginia all rights, title and interest in and to all causes of action it may now or hereafter acquire under the antitrust laws of the United States and the State of West Virginia for price fixing and/or unreasonable restraints of trade relating to the particular commodities or services purchased or acquired by the State of West Virginia. Such assignment shall be made and become effective at the time the purchasing agency tenders the initial payment to the bidder.

I certify that this bid is made without prior understanding, agreement, or connection with any corporation, firm, limited liability company, partnership, or person or entity submitting a bid for the same material, supplies, equipment or services and is in all respects fair and without collusion or Fraud. I further certify that I am authorized to sign the certification on behalf of the bidder or this bid.

INSTRUCTIONS TO BIDDERS

1. Use the quotation forms provided by the Purchasing Division. Complete all sections of the quotation form.
2. Items offered must be in compliance with the specifications. Any deviation from the specifications must be clearly indicated by the bidder. Alternates offered by the bidder as EQUAL to the specifications must be clearly defined. A bidder offering an alternate should attach complete specifications and literature to the bid. The Purchasing Division may waive minor deviations to specifications.
3. Unit prices shall prevail in case of discrepancy. All quotations are considered F.O.B. destination unless alternate shipping terms are clearly identified in the quotation.
4. All quotations must be delivered by the bidder to the office listed below prior to the date and time of the bid opening. Failure of the bidder to deliver the quotations on time will result in bid disqualifications: Department of Administration, Purchasing Division, 2019 Washington Street East, P.O. Box 50130, Charleston, WV 25305-0130
5. Communication during the solicitation, bid, evaluation or award periods, except through the Purchasing Division, is strictly prohibited (W.Va. C.S.R. §148-1-6.6).



State of West Virginia
 Department of Administration
 Purchasing Division
 2019 Washington Street East
 Post Office Box 50130
 Charleston, WV 25305-0130

Request for Quotation

RFQ NUMBER
7011EC15

PAGE
2

ADDRESS CORRESPONDENCE TO ATTENTION OF:
 BUYER 33
 304-558-2402

RFQ COPY
 TYPE NAME/ADDRESS HERE

VENDOR

SHIP TO

DIVISION OF HIGHWAYS
 EQUIPMENT DIVISION
 ROUTE 33
 BRUSHY FORK ROAD
 BUCKHANNON, WV
 26201 304-472-1750

DATE PRINTED	TERMS OF SALE	SHIP VIA	FOB	FREIGHT TERMS
12/29/2010				

BID OPENING DATE: **02/24/2011** BID OPENING TIME **01:30PM**

LINE	QUANTITY	UOP	CAT NO.	ITEM NUMBER	UNIT PRICE	AMOUNT
<p>FAILURE TO ATTEND THE MANDATORY PRE-BID SHALL RESULT IN DISQUALIFICATION OF THE BID. NO ONE PERSON MAY REPRESENT MORE THAN ONE BIDDER.</p> <p>AN ATTENDANCE SHEET WILL BE MADE AVAILABLE FOR ALL POTENTIAL BIDDERS TO COMPLETE. THIS WILL SERVE AS THE OFFICIAL DOCUMENT VERIFYING ATTENDANCE AT THE MANDATORY PRE-BID. FAILURE TO PROVIDE YOUR COMPANY AND REPRESENTATIVE NAME ON THE ATTENDANCE SHEET WILL RESULT IN DISQUALIFICATION OF THE BID. THE STATE WILL NOT ACCEPT ANY OTHER DOCUMENTATION TO VERIFY ATTENDANCE. THE BIDDER IS RESPONSIBLE FOR ENSURING THEY HAVE COMPLETED THE INFORMATION REQUIRED ON THE ATTENDANCE SHEET. THE PURCHASING DIVISION AND THE STATE AGENCY WILL NOT ASSUME ANY RESPONSIBILITY FOR A BIDDER'S FAILURE TO COMPLETE THE PRE-BID ATTENDANCE SHEET. IN ADDITION, WE REQUEST THAT ALL POTENTIAL BIDDERS INCLUDE THEIR E-MAIL ADDRESS AND FAX NUMBER.</p> <p>ALL POTENTIAL BIDDERS ARE REQUESTED TO ARRIVE PRIOR TO THE STARTING TIME FOR THE PRE-BID. BIDDERS WHO ARRIVE LATE, BUT PRIOR TO THE DISMISSAL OF THE TECHNICAL PORTION OF THE PRE-BID WILL BE PERMITTED TO SIGN IN. BIDDERS WHO ARRIVE AFTER CONCLUSION OF THE TECHNICAL PORTION OF THE PRE-BID, BUT DURING ANY SUBSEQUENT PART OF THE PRE-BID WILL NOT BE PERMITTED TO SIGN THE ATTENDANCE SHEET.</p> <p>EXHIBIT 10</p> <p>REQUISITION NO.: 7011EC15</p> <p>ADDENDUM ACKNOWLEDGEMENT</p> <p>I HEREBY ACKNOWLEDGE RECEIPT OF THE FOLLOWING CHECKED</p>						

SEE REVERSE SIDE FOR TERMS AND CONDITIONS

SIGNATURE	TELEPHONE	DATE
TITLE	FEIN	ADDRESS CHANGES TO BE NOTED ABOVE

WHEN RESPONDING TO RFQ, INSERT NAME AND ADDRESS IN SPACE ABOVE LABELED 'VENDOR'



State of West Virginia
 Department of Administration
 Purchasing Division
 2019 Washington Street East
 Post Office Box 50130
 Charleston, WV 25305-0130

Request for Quotation

RFQ NUMBER
7011EC15

PAGE
3

ADDRESS CORRESPONDENCE TO ATTENTION OF:
**BUYER 33
 304-558-2402**

RFQ COPY
 TYPE NAME/ADDRESS HERE

VENDOR

BUYER

DIVISION OF HIGHWAYS
 EQUIPMENT DIVISION
 ROUTE 33
 BRUSHY FORK ROAD
 BUCKHANNON, WV
 26201 304-472-1750

DATE PRINTED	TERMS OF SALE	SHIP VIA	F.O.B.	FREIGHT TERMS
12/29/2010				

BID OPENING DATE: **02/24/2011** BID OPENING TIME **01:30PM**

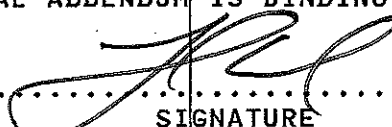
LINE	QUANTITY	UOP	CAT NO	ITEM NUMBER	UNIT PRICE	AMOUNT
<p>ADDENDUM(S) AND HAVE MADE THE NECESSARY REVISIONS TO MY PROPOSAL, PLANS AND/OR SPECIFICATION, ETC.</p> <p>ADDENDUM NO.'S:</p> <p>NO. 1 ✓</p> <p>NO. 2</p> <p>NO. 3</p> <p>NO. 4</p> <p>NO. 5</p> <p>I UNDERSTAND THAT FAILURE TO CONFIRM THE RECEIPT OF THE ADDENDUM(S) MAY BE CAUSE FOR REJECTION OF BIDS.</p> <p>VENDOR MUST CLEARLY UNDERSTAND THAT ANY VERBAL REPRESENTATION MADE OR ASSUMED TO BE MADE DURING ANY ORAL DISCUSSION HELD BETWEEN VENDOR'S REPRESENTATIVES AND ANY STATE PERSONNEL IS NOT BINDING. ONLY THE INFORMATION ISSUED IN WRITING AND ADDED TO THE SPECIFICATIONS BY AN OFFICIAL ADDENDUM IS BINDING.</p> <p style="text-align: right;">  SIGNATURE <i>CH. Jones Equip. Co.</i> COMPANY <i>2/22/11</i> DATE </p>						

SEE REVERSE SIDE FOR TERMS AND CONDITIONS

SIGNATURE	TELEPHONE	DATE
TITLE	FEIN	ADDRESS CHANGES TO BE NOTED ABOVE

WHEN RESPONDING TO RFQ, INSERT NAME AND ADDRESS IN SPACE ABOVE LABELED 'VENDOR'



State of West Virginia
 Department of Administration
 Purchasing Division
 2019 Washington Street East
 Post Office Box 50130
 Charleston, WV 25305-0130

Request for Quotation

RFO NUMBER
7011EC15

PAGE
4

ADDRESS CORRESPONDENCE TO ATTENTION OF
**BUYER 33
 304-558-2402**

RFQ COPY
 TYPE NAME/ADDRESS HERE

VENDOR

SHIP TO

**DIVISION OF HIGHWAYS
 EQUIPMENT DIVISION
 ROUTE 33
 BRUSHY FORK ROAD
 BUCKHANNON, WV
 26201 304-472-1750**

DATE PRINTED	TERMS OF SALE	SHIP VIA	FOB	FREIGHT TERMS
12/29/2010				

BID OPENING DATE: **02/24/2011** BID OPENING TIME **01:30PM**

LINE	QUANTITY	UOP	CAT NO	ITEM NUMBER	UNIT PRICE	AMOUNT
<p>NOTE: THIS ADDENDUM ACKNOWLEDGEMENT SHOULD BE SUBMITTED WITH THE BID.</p> <p>REV. 09/21/2009</p> <p>EXHIBIT 2</p> <p>LIFE OF CONTRACT: THIS CONTRACT BECOMES EFFECTIVE ON AND EXTENDS FOR A PERIOD OF ONE (1) YEAR OR UNTIL SUCH "REASONABLE TIME" THEREAFTER AS IS NECESSARY TO OBTAIN A NEW CONTRACT OR RENEW THE ORIGINAL CONTRACT. THE "REASONABLE TIME" PERIOD SHALL NOT EXCEED TWELVE (12) MONTHS. DURING THIS "REASONABLE TIME" THE VENDOR MAY TERMINATE THIS CONTRACT FOR ANY REASON UPON GIVING THE DIRECTOR OF PURCHASING THIRTY (30) DAYS WRITTEN NOTICE.</p> <p>UNLESS SPECIFIC PROVISIONS ARE STIPULATED IN THIS CONTRACT DOCUMENT, THE TERMS, CONDITIONS, AND PRICING SET HEREIN ARE FIRM FOR THE LIFE OF THE CONTRACT.</p> <p>RENEWAL: THIS CONTRACT MAY BE RENEWED UPON THE MUTUAL WRITTEN CONSENT OF THE SPENDING UNIT AND VENDOR, SUBMITTED TO THE DIRECTOR OF PURCHASING THIRTY (30) DAYS PRIOR TO THE EXPIRATION DATE. SUCH RENEWAL SHALL BE IN ACCORDANCE WITH THE TERMS AND CONDITIONS OF THE ORIGINAL CONTRACT AND SHALL BE LIMITED TO TWO (2) ONE (1) YEAR PERIODS.</p> <p>CANCELLATION: THE DIRECTOR OF PURCHASING RESERVES THE RIGHT TO CANCEL THIS CONTRACT IMMEDIATELY UPON WRITTEN NOTICE TO THE VENDOR IF THE COMMODITIES AND/OR SERVICES SUPPLIED ARE OF AN INFERIOR QUALITY OR DO NOT CONFORM WITH THE SPECIFICATIONS OF THE BID AND CONTRACT HEREIN.</p>						

SEE REVERSE SIDE FOR TERMS AND CONDITIONS

SIGNATURE	TELEPHONE	DATE
TITLE	FEIN	ADDRESS CHANGES TO BE NOTED ABOVE

WHEN RESPONDING TO RFQ, INSERT NAME AND ADDRESS IN SPACE ABOVE LABELED 'VENDOR'



State of West Virginia
 Department of Administration
 Purchasing Division
 2019 Washington Street East
 Post Office Box 50130
 Charleston, WV 25305-0130

Request for Quotation

RFQ NUMBER
7011EC15

PAGE
5

ADDRESS CORRESPONDENCE TO ATTENTION OF
BUYER 33 304-558-2402

VENDOR

RFQ COPY
 TYPE NAME/ADDRESS HERE

BUYER

DIVISION OF HIGHWAYS
 EQUIPMENT DIVISION
 ROUTE 33
 BRUSHY FORK ROAD
 BUCKHANNON, WV
 26201 304-472-1750

DATE PRINTED	TERMS OF SALE	SHIP VIA	F.O.B.	FREIGHT TERMS
12/29/2010				

BID OPENING DATE: 02/24/2011 BID OPENING TIME 01:30PM

LINE	QUANTITY	UOP	CAT NO.	ITEM NUMBER	UNIT PRICE	AMOUNT
<p>OPEN MARKET CLAUSE: THE DIRECTOR OF PURCHASING MAY AUTHORIZE A SPENDING UNIT TO PURCHASE ON THE OPEN MARKET, WITHOUT THE FILING OF A REQUISITION OR COST ESTIMATE, ITEMS SPECIFIED ON THIS CONTRACT FOR IMMEDIATE DELIVERY IN EMERGENCIES DUE TO UNFORESEEN CAUSES (INCLUDING BUT NOT LIMITED TO DELAYS IN TRANSPORTATION OR AN UNANTICIPATED INCREASE IN THE VOLUME OF WORK).</p> <p>QUANTITIES: QUANTITIES LISTED IN THE REQUISITION ARE APPROXIMATIONS ONLY, BASED ON ESTIMATES SUPPLIES BY THE STATE SPENDING UNIT. IT IS UNDERSTOOD AND AGREED THAT THE CONTRACT SHALL COVER THE QUANTITIES ACTUALLY ORDERED FOR DELIVERY DURING THE TERM OF CONTRACT, WHETHER MORE OR LESS THAN THE QUANTITIES SHOWN.</p> <p>ORDERING PROCEDURE: SPENDING UNIT(S) SHALL ISSUE A WRITTEN EQUIPMENT CONTRACT ORDER (FORM NUMBER WV-35) FOR COMMODITIES COVERED BY THIS CONTRACT. THE ORIGINAL WV-35 MUST BE SENT TO THE PURCHASING DIVISION OF THE DEPARTMENT OF ADMINISTRATION. AFTER APPROVAL AND ENCUMBRANCE, ONE COPY OF THE PURCHASE ORDER WILL BE RETURNED TO THE SPENDING UNIT AND ONE COPY FORWARDED TO THE VENDOR AS AUTHORIZATION FOR SHIPMENT. NO ORDER IS VALID UNLESS APPROVED AND ENCUMBERED BY THE PURCHASING DIVISION.</p> <p>BANKRUPTCY: IN THE EVENT THE VENDOR/CONTRACTOR FILES FOR BANKRUPTCY PROTECTION, THE STATE MAY DEEM THE CONTRACT NULL AND VOID, AND TERMINATE SUCH CONTRACT WITHOUT FUTHER ORDER.</p> <p>REV. 5/2009</p> <p>EXHIBIT 4</p>						

SEE REVERSE SIDE FOR TERMS AND CONDITIONS

SIGNATURE	TELEPHONE	DATE
TITLE	FEIN	ADDRESS CHANGES TO BE NOTED ABOVE

WHEN RESPONDING TO RFQ, INSERT NAME AND ADDRESS IN SPACE ABOVE LABELED 'VENDOR'



State of West Virginia
 Department of Administration
 Purchasing Division
 2019 Washington Street East
 Post Office Box 50130
 Charleston, WV 25305-0130

Request for Quotation

RFQ NUMBER:
7011EC15

PAGE:
6

ADDRESS CORRESPONDENCE TO ATTENTION OF:
**BUYER 33
 304-558-2402**

RFQ COPY
 TYPE NAME/ADDRESS HERE

VENDOR

SHIP TO

**DIVISION OF HIGHWAYS
 EQUIPMENT DIVISION
 ROUTE 33
 BRUSHY FORK ROAD
 BUCKHANNON, WV
 26201 304-472-1750**

DATE PRINTED	TERMS OF SALE	SHIP VIA	F.O.B.	FREIGHT TERMS
12/29/2010				

BID OPENING DATE: **02/24/2011** BID OPENING TIME **01:30PM**

LINE	QUANTITY	UOP	CAT NO.	ITEM NUMBER	UNIT PRICE	AMOUNT
<p>LOCAL GOVERNMENT BODIES: UNLESS THE VENDOR INDICATES IN THE BID HIS REFUSAL TO EXTEND THE PRICES, TERMS, AND CONDITIONS OF THE BID TO COUNTY, SCHOOL, MUNICIPAL AND OTHER LOCAL GOVERNMENT BODIES, THE BID SHALL EXTEND TO POLITICAL SUBDIVISIONS OF THE STATE OF WEST VIRGINIA. IF THE VENDOR DOES NOT WISH TO EXTEND THE PRICES, TERMS, AND CONDITIONS OF THE BID TO ALL POLITICAL SUBDIVISIONS OF THE STATE, THE VENDOR MUST CLEARLY INDICATE SUCH REFUSAL IN HIS BID. SUCH REFUSAL SHALL NOT PREJUDICE THE AWARD OF THIS CONTRACT IN ANY MANNER.</p> <p>REV. 3/88</p> <p style="text-align: center;">NOTICE</p> <p>A SIGNED BID MUST BE SUBMITTED TO:</p> <p style="text-align: center;">DEPARTMENT OF ADMINISTRATION PURCHASING DIVISION BUILDING 15 2019 WASHINGTON STREET, EAST CHARLESTON, WV 25305-0130</p> <p>THE BID SHOULD CONTAIN THIS INFORMATION ON THE FACE OF THE ENVELOPE OR THE BID MAY NOT BE CONSIDERED:</p> <p>SEALED BID</p> <p>BUYER: SHERI SLONE - FILE 33</p>						

SEE REVERSE SIDE FOR TERMS AND CONDITIONS

SIGNATURE	TELEPHONE	DATE
TITLE	FEIN	ADDRESS CHANGES TO BE NOTED ABOVE

WHEN RESPONDING TO RFQ, INSERT NAME AND ADDRESS IN SPACE ABOVE LABELED 'VENDOR'



State of West Virginia
 Department of Administration
 Purchasing Division
 2019 Washington Street East
 Post Office Box 50130
 Charleston, WV 25305-0130

Request for Quotation

RFQ NUMBER
7011EC15

PAGE
7

ADDRESS CORRESPONDENCE TO ATTENTION OF:
**BUYER 33
 304-558-2402**

RFQ COPY
 TYPE NAME/ADDRESS HERE

**DIVISION OF HIGHWAYS
 EQUIPMENT DIVISION
 ROUTE 33
 BRUSHY FORK ROAD
 BUCKHANNON, WV
 26201 304-472-1750**

DATE PRINTED	TERMS OF SALE	SHIP VIA	F.O.B.	FREIGHT TERMS
12/29/2010				

BID OPENING DATE: **02/24/2011** BID OPENING TIME **01:30PM**

LINE	QUANTITY	UOP	CAT NO.	ITEM NUMBER	UNIT PRICE	AMOUNT
				7011EC15		
				02/24/2011		
				1:30 PM		
PLEASE PROVIDE A FAX NUMBER IN CASE IT IS NECESSARY TO CONTACT YOU REGARDING YOUR BID: <i>304 292 6641</i>						
CONTACT PERSON (PLEASE PRINT CLEARLY): <i>LEIN HANCOCK</i>						
***** THIS IS THE END OF RFQ 7011EC15 ***** TOTAL:						<i>See Ps. 1</i>

SEE REVERSE SIDE FOR TERMS AND CONDITIONS

SIGNATURE	TELEPHONE	DATE
TITLE	FEIN	ADDRESS CHANGES TO BE NOTED ABOVE

WHEN RESPONDING TO RFQ, INSERT NAME AND ADDRESS IN SPACE ABOVE LABELED 'VENDOR'

WEST VIRGINIA DEPARTMENT OF TRANSPORTATION
DIVISION OF HIGHWAYS
EQUIPMENT DIVISION

BIDDER'S EVALUATION REPORT

PROCUREMENT SPECIFICATIONS FOR OPEN END CONTRACT
NO. 013-2-C

NINE CUBIC YARD 304 STAINLESS STEEL
DEMOUNTABLE ABRASIVE AND CHEMICAL SPREADER (HYDRAULIC)

NOTE TO BIDDER: Procurement Specification No. 013-2-C, Paragraph 2.0 recommends the completion and submittal of this Report with your bid. Purpose of this Report is to enable the West Virginia Division of Highways Evaluation Committee to make full and fair evaluation of the bid. Addendums in order, along with a summary of exception as a separate attachment, should be with Bidder's Evaluation Report. FAILURE TO SUBMIT THIS REPORT, COMPLETE IN ITS ENTIRETY, MAY SUBJECT THE BIDDER TO DISQUALIFICATION.

Reference Requisition No.: 7011 EC15

Bidder's Name: LH Jones Equipment Co.

Address: 1825 Earl L. Cox Rd. Morgantown WV 26505

Telephone Number: 304 297 1307

Years Bidder has been registered to do business with the State of West Virginia: 33 YRS.

Years Company has been an authorized dealer for proposed unit: 4 YRS.

X3.2 Have you complied with all mandatory specifications? YES NO

X4.2 DELIVERY:

X4.2.1 Delivery date of completed representative unit: 45 Calendar Days After Receipt of Purchase Agreement

X4.2.2 Delivery date of balance of completed units: 135 Calendar Days After Receipt of Purchase Agreement

X5.0 AWARD CRITERIA;

X5.1 Price per unit:

14,168.00 per unit
24

Fourteen thousand one hundred sixty-eight

X6.0 SPECIFICATIONS - GENERAL

X6.1 Manufacturer, model, series, and date of manufacture of proposed unit:

Byers Products, Model Byers, Series 145, mfg. 2011
Is descriptive literature, fully describing proposed unit attached to your bid? YES NO

If not, why? Literature depicts standard unit. Bid unit modified to comply with bid specifications.

X6.2 Will the required number of service manuals, and complete parts list be delivered to the Equipment Division at Buckhannon upon completion of delivery of total units?

YES NO

Will the required Equipment Preventive Maintenance Form (Section X6.2 of Bidders Evaluation Report) be provided upon inspection of the pilot unit?

YES NO

EQUIPMENT PREVENTATIVE MAINTENANCE QUESTIONNAIRE

THIS FORM MUST BE COMPLETED IN ITS ENTIRETY BY SUCCESSFUL BIDDER OR MANUFACTURER'S TECHNICAL REPRESENTATIVE PRIOR TO DELIVERY OF PILOT MODEL TO THE WVDOH.

DESCRIPTION: _____ MAKE: _____

MODEL: _____ YEAR: _____ PURCHASE AMOUNT: _____

ENGINE: MAKE: _____ MODEL: _____ FUEL TYPE: _____

HORSEPOWER: _____ CYLINDER: _____ ENGINE SERIAL: _____

COOLING SYSTEM CAPACITY: _____

BELTS:	DESCRIPTION:	PART NUMBERS:
	_____	_____
	_____	_____

GVW: _____ AXLE CAPACITY: FRONT: _____ REAR: _____

TIRES: FRONT MAKE & SIZE: _____

REAR MAKE & SIZE: _____

DIMENSIONS OF UNIT: LENGTH: _____ WIDTH: _____ LENGTH: _____

VENDOR CONTACT PERSON: _____ PHONE: _____

PARTS:

BATTERY MAKE: _____	MODEL: _____	CCA: _____
TOP OR SIDE POST: _____	DIMENSIONS: LENGTH _____	WIDTH _____ HEIGHT _____
SPARK PLUGS OR FUEL INJECTORS MAKE: _____	PART # _____	
FUEL PUMP OR INJECTION PUMP MAKE: _____	MODEL: _____	
ALTERNATOR MAKE: _____	PART #: _____	
STARTER MAKE: _____	PART #: _____	
TURBO CHARGER MAKE: _____	PART #: _____	
TRANS. MAKE: _____	MODEL: _____	AUTO/MANUAL: _____
HYDRAULIC PUMP MAKE: _____	MODEL: _____	

FILTERS	MAKE	PART NO.	LUBRICANT	MANUFACTURER TYPE
OIL	_____	_____	ENGINE	_____
AIR INNER	_____	_____	TRANSMISSION	_____
AIR OUTER	_____	_____	POWER STEERING	_____
FUEL PRIMARY	_____	_____	HYDRAULIC	_____
FUEL SECONDARY	_____	_____	DIFFERENTIALS	_____
COOLANT	_____	_____	BRAKE FLUID	_____
HYDRAULIC	_____	_____	COOLANT	_____
OTHER	_____	_____	OTHER	_____

X6.3 TRAINING:

Will training seminar be conducted on Preventive Maintenance, Operator and Mechanic Training YES NO

Will you conduct training with each purchase order against this open end contract? YES NO

Will training be conducted within 2 working days from the delivery of the pilot unit on the individual purchase order? YES NO

If NO, explain time frame _____

Will an Operator's Manual be furnished directly to Training Academy prior to the delivery of the pilot? YES NO

X6.4 If you are the successful vendor, will you furnish all training aids, i.e., videos, projectors, required in conducting the training? YES NO

X6.4.1 Will all manuals, booklets, etc. explaining preventive maintenance, operator procedures, and service schedule be delivered with each unit? YES NO
If NO, explain _____

X6.5 WARRANTY AND SERVICE POLICY

Will the warranty and service you provide comply with all areas as stated in Section 6.5 of specifications YES NO

Is warranty literature attached? YES NO

Is a minimum two (2) year bumper to bumper basic parts and labor warranty excluding abuse and normal wear items included? YES NO

Describe: See Attached

X6.6 EVALUATION COMMITTEE REQUIREMENTS

Is all component specifications, product literature, component models provided for Evaluation Committee bid determination? YES NO

X6.7 Will all parts, equipment, accessories, material, design and performance characteristics not specified herein, but which are necessary to provide a complete unit, be furnished with the unit and conform in strength, quality of material, and quality of workmanship to those which are advertised and provided to the market in general by the unit industry? YES NO

X6.7.1 Are all parts and accessories adequate and regularly supplied as standard to be included except those which may be duplications of specifications herein, and except these by specification are not to be furnished? YES NO

X6.7.2 Are all standard safety features that are required by Federal and State statutes of law included? YES NO

X7.0 SPECIFICATIONS OF THE QUOTED UNIT

The bidder should complete the following schedule in order for the Division to compare the actual bid unit to the specifications. Should the bidder except a requirement, then such exception may be only on the basis that such feature is not offered by the manufacturer. The Division will have the sole discretion as to whether the bidder's substitution meets the requirements of the specifications.

Manufacturer: Buyers Products Model: 14543 Series

X7.1 Is spreaders offered the commercial heavy duty, self contained, hopper type? YES NO

X7.2 Does spreader consist of a 12 gauge 304 stainless steel body, feeder conveyor, spinner disc, power drive, and all components necessary to make a complete operating unit? YES NO

X7.3 Is the unit capable of uniformly spreading sand, cinders, salt, calcium chloride, or other mixtures up to a width of forty (40) feet? YES NO

X7.4 Body:

X7.4.1 Is the body of 304 stainless steel construction 100% welded inside and outside of the body? YES NO

X7.4.2 Capacity struck: 9.3 cubic yards

X7.4.3 Inside length: 13 feet as measured from front of spreader hopper to the rear hopper gate and conveyor chain exit point

- X7.4.4 Overall height: 57 inches
- X7.4.5 Inside width: 82 inches
- X7.4.6 Are the body sides sloped approximately 45 degree pitch to insure free flow of materials to the conveyor YES NO
- X7.4.7 Gauge of 304 stainless steel in sides and endgates is 10 Gauge.
- X7.4.8 Is a formed double crimped section on top of body for additional support? YES NO
- X7.4.9 Sills constructed of 10 gauge 304 stainless steel.
Supported on rectangular formed cross sills YES NO
- X7.4.10 Number of 10 gauge full slope body side supports tying the cross sills with body sides? 6
- X7.4.11 Are there four (4) 304 stainless steel 5/8 inch round lifting eyes YES NO
Is the inside eye opening designed to allow the passage of an alloy eye type Grade 80' 3/8 inch grab hook with a width dimension of 2 11/16 inch (with the top screen down in the rest position on top of the spreader) YES NO
Two (2) on each side of spreader mounted and secured in a manner that the entire unit may be safely lifted for storage/installation purposes YES NO
- X7.4.12 Is all necessary hardware stainless steel YES NO
- X7.4.13 Will a 12 gauge 304 stainless steel cabshield be mounted on the front of body to protect cab from falling material when loading with slope design to fall in hopper as spreader unloads? YES NO
Does cab shield extend 13 inches in front of the hopper at 45 degrees YES NO
- X7.4.13.1 Is a 300 series stainless steel grab handle mounted to the drivers side spill shield side plate at a convenient location to assist operator when climbing atop spreader to remove "chunks or debris" YES NO
- X7.4.14 Is a fold up stainless steel ladder be mounted on the rear of spreader body at right side for easier access to top YES NO
Is the ladder equipped with hand holds, non slip strut steps, and manufacturers locking mechanism to lock ladder in up position when not in use YES NO
- X7.4.14.1 Is a 300 series stainless steel grip strut step plate mounted on rear of spreader "spinner" housing frame, above rear baffle, full width of spinner housing YES NO
- X7.4.15 Is a work light mounted on cab shield for night shift visibility of spreader grating with weatherproof wiring YES NO

X7.5 Conveyor:

- X7.5.1 Is the conveyor located in bottom of hopper and capable of engaging material along its full length and moving material to rear adjustable metering gate? YES NO
- X7.5.2 Is conveyor continuous ladder type consisting of two parallel chains with cross bars on 4 2" centers made of 1/4" x 1-1/2" steel? YES NO
- X7.5.3 Is each cross bar formed and welded both top and bottom to chain links YES NO
- X7.5.4 Tensile strength of each chain strand: 21,000 pounds
- X7.5.5 Overall width of chain conveyor: 24 inches
- X7.5.6 Are replaceable rubber wear strips provided to prevent contact of material being spread with the chain? YES NO
- X7.5.7 Is a 10 gauge 304 stainless steel heavy-duty replaceable conveyor plate fitted YES NO
- X7.5.8 Is the chain drive through 1-1/2" sprockets and shafting front and rear? YES NO 2" front
- X7.5.9 Does conveyor have adjustment provisions at rear of spreader for at least 3" lateral takeup? YES NO
- X7.5.10 Is additional 7 gauge 304 stainless steel reinforcing plate welded to longitudinal webs covering the area of the drive shaft, bearing, and idler bearing provided (if required)? YES NO not required
- X7.5.11 Is material composition of adjustment mechanism stainless steel YES NO
- X7.5.12 Is conveyor drive motor mounted on reduction gear box and has a ratio of approximately 50-1 YES NO
- X7.5.13 Does conveyor gear box motor have an integral speed sensor? YES NO
- X7.5.13.1 Is the shaft end machined to accommodate the application rate sensor shaft for the Dickey-John Automatic Control System, Model ICS-2000? YES NO
- X7.5.13.2 Is the necessary oil seal included? YES NO
- X7.5.14 Is a 7 gauge stainless steel adjustable greasable screw jack type discharge gate located at the body rear to adjust the flow of material to the spinner? YES NO
- X7.5.15 Feedgate opening: 10 inches high x 18 5/8 inches wide
- X7.5.16 Is any and all exposed moving or rotating mass adequately shielded in order to protect personnel while performing required operational adjustments including gear box extended input shaft when rate sensor is installed? YES NO

X7.5.17 Is the pintle conveyor chain heat treated form links with locked, non-turning pins YES NO

X7.6 Distributor Spinner Assembly:

X7.6.1 Diameter of urethane distributor disc 20 inches

X7.6.1.1 Number of fins: 6

X7.6.1.2 Are fins designed to obtain a controlled spread of materials from four feet (4') to forty feet (40')? YES NO

X7.6.2 Is material guided from conveyor end to distributor disc by means of an externally adjustable material flow baffles, enclosed within the chute? YES NO

X7.6.3 Spinner is vertically adjustable 12.8 inches and provides a 385 inch spinner position below the mounting surface

X7.6.4 Is a deflector baffle or diverter chute provided in an enclosed distributor spinner hopper assembly so it can be positioned in such a manner that material can be unloaded from spreader without striking spinner? YES NO

X7.7 Baffles:

X7.7.1 Are baffles provided to control direction and width of spread? YES NO

X7.7.1.2 Are there four (4) sections over right, left, rear and front of spinners? YES NO

Is front spinner baffle shield (truck side) stationary YES NO

X7.7.2 Are sections easily adjusted from the full down to the horizontal position without use of tools? YES NO

X7.8. Power Drive:

X7.8.1 Is the power drive hydraulic type? YES NO

X7.8.1.2 Are two (2) hydraulic motors provided - one (1) powering the spinner assembly and one (1) powering the conveyor? YES NO

X7.8.2 Spinner hydraulic motor mounted below the spinner hopper assembly? YES NO

X7.8.3 The conveyor hydraulic motor of the orbital, low speed, hi-torque integrally mounted to conveyor gear box? YES NO

X7.9 Screen Over Hopper:

X7.9.1 Are four (4) sectional screens hinged to 10 gauge 304 stainless steel ~~4 inch~~ x 6 inch formed box beam running longitudinally the full length of spreader hopper? YES NO

If not specify: 6 screens

X7.9.2 Do screen sections have 3/8" diameter carbon steel rods welded forming 2-1/2" x 2-1/2" square openings with reinforcing bars at the center of each section? YES NO

If not specify: 3" x 3" square openings

X7.9.3 Do screens increase overall height of spreader more than 7 inches down the center? YES NO

X7.9.4 Are screens powder coated black YES NO

X7.10 Is lighting in accordance with the attached sketch and wiring schematic? YES NO

X7.10.1 Is the combination and marker lights LED type YES NO

X7.10.2 Are stop, tail, turn combination lights and marker lights shielded YES NO

X7.10.3 Is strobe light "quad flash" YES NO

X7.11 Hydraulic Components:

X7.11.1 Are all necessary fittings for complete hookup of spreader hydraulics to DOH dump trucks central hydraulic system provided? YES NO

X7.11.2 Are all fittings of the steel type and designed for hydraulic use? YES NO

X7.11.3 Will the hoses mate with the quick disconnects on the central hydraulic system of the truck? YES NO

Will you furnish the male quick disconnects, metal caps, and plugs for connection to truck manifold YES NO

X7.12 Is an anodized 6061T6 aluminum YES NO
(OR)

304 stainless steel YES NO grease manifold block mounted at the rear of the body which incorporates the front bearing grease extension tubes, rear bearing grease fittings and feedgate screw jack lubrication tube to allow for lubrication of the front bearings and feedgate screw jack from a single convenient location? YES NO

Other fittings are placed at convenient location for normal maintenance YES NO

X7.12.1 The anodized 6061T6 aluminum YES NO
(OR)

304 stainless steel grease manifold block YES NO

Has 6 ports tapped to accept three (3) 1/8 inch straight grease zerks and three (3) 1/8 inch grease Parflex hoses to provide adequate one location greasing of the front and rear bearings and feed gate screw jack YES NO

Are any unused ports properly plugged YES NO

X7.12.2 Are hoses used in the grease manifold system Parflex hose by Parker Hannifin or equal, with 1/8 inch I.D., 0.34 inch maximum O.D., a maximum working pressure of 2500 PSI and a minimum burst pressure of 10,000 PSI? YES NO

Are hose assemblies held in place by a sufficient number of rubber cushioned hose clamps? YES NO

X7.13 Is one (1) piece of angle iron 3/8" x 4" X 90" and two (2) pieces of 1" round shafting ten inches (10") long provided but not installed for each unit? YES NO

X7.14 Other standard features:

List other standard features offered but not specifically addressed above:

X7.15 Paint:

Describe method of painting parts and accessories that are not required to be stainless or rustproof:

Top screens powder coated black

X7.16 Does unit offered meet or exceed "Occupational Safety and Health Act of 1970"? YES NO

X7.17 Does unit conform to the advertising guidelines? YES NO



State of West Virginia
Department of Administration
Purchasing Division
2019 Washington Street East
Post Office Box 50130
Charleston, WV 25305-0130

Request for Quotation

REG NUMBER 7011EC15

PAGE 1

ADDRESS CORRESPONDENCE TO ATTENTION OF BUYER 33 304-558-2402

PROPERTY

*709043957 01 304-292-1307
L H JONES EQUIP CO
1825 EARL CORE ROAD
MORGANTOWN WV 26505

SHIP TO

DIVISION OF HIGHWAYS
EQUIPMENT DIVISION
ROUTE 33
BRUSHY FORK ROAD
BUCKHANNON, WV 26201 304-472-1750

Table with columns: DATE PRINTED (02/17/2011), TERMS OF SALE (Net 30 days), SHIP VIA (Meta Freight), FOB (Buckhannon, WV), FREIGHT TERMS (No charge), BID OPENING DATE (02/23/2011), BID OPENING TIME (01:30PM)

Main bid table with columns: LINE, QUANTITY, UOP, CAT NO, ITEM NUMBER, UNIT PRICE, AMOUNT. Includes addendum text and item 0001: 9 CUBIC YARD ABRASIVE AND CHEMICAL SPREADER.

Signature and contact information section including SIGNATURE, TELEPHONE (304 292 1307), DATE (2/22/11), TITLE (C.O.O.), and FEIN (55-057865).

WHEN RESPONDING TO RFQ, INSERT NAME AND ADDRESS IN SPACE ABOVE LABELED 'VENDOR'

PREBID ADDENDUM #1
7011EC159 CUBIC YARD STAINLESS STEEL
DEMOUNTABLE ABRASIVE AND CHEMICAL SPREADER (HYDRAULIC)

CHANGES TO BIDDER'S EVALUATION REPORT:

FROM:

X7.2 Does spreader consist of a 12 gauge 304 stainless steel body, feeder conveyor, spinner disc, power drive, and all components necessary to make a complete operating unit? YES NO

TO:

X7.2 Spreader consists of a 10 gauge 304 stainless steel body, feeder conveyor, spinner disc, power drive, and all components necessary to make a complete operating unit? YES NO

FROM:

X7.4.2 Capacity struck: cubic yards

TO:

X7.4.2 Struck capacity: 9.3 cubic yards

FROM:

X7.5.12 Is conveyor drive motor mounted on reduction gear box and has a ratio of approximately 50:1? YES NO

TO:

X7.5.12 Is conveyor drive motor mounted on rear of the reduction gear box YES NO
And ratio of 50:1

NO CHANGE REQUIRED:

X7.6.4 Is a deflector baffle or diverter chute provided in an enclosed distributor spinner hopper assembly so it can be positioned in such a manner that material can be unloaded from spreader without striking spinner? YES NO

FROM:**X7.10.3** Is strobe light "quad flash" YES NO**TO:****X7.10.3** Is warning light Class 1 LED amber? YES NO**FROM:****X7.13** Is one (1) piece of angle iron 3/8" x 4" x 90" and two (2) pieces of 1" round shafting ten inches (10") long provided but not installed for each? YES NO**TO:****X7.13** Is one (1) piece of angle iron 3/8" x 4" x 4" x 90" and two (2) pieces of 1" round shafting ten inches (10") long provided but not installed for each? YES NO

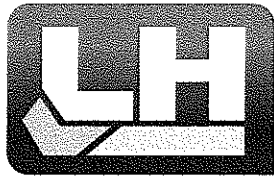

LH JONES
EQUIPMENT

February 22, 2011

State of West Virginia
Department of Administration
Purchasing Division
2019 Washington Street East
PO Box 50130
Charleston, WV 25305-0130

Bid Enclosure
Exceptions to Specifications and Other
Notes

RE: RFQ 7011EC15

To Whom It May Concern:

LH Jones hereby opts out of the "Local Government Bodies" section of the RFQ.

LH Jones requests a price adjustment provision, if allowed.

Exceptions to Specifications (Some exceed specifications)

- 7.5.8 Drive sprocket & shaft is 2" diameter
- 7.5.15 Feedgate opening is 10" x 18-5/8"
- 7.6.3 Spinner vertically adjustable 12.8"
- 7.9.2 3/8" Diameter rod to 1/4" x 2" Angle with 3" x 3" openings

Notes

- 7.5.10 Not required

Very truly yours,

A handwritten signature in black ink, appearing to read 'LH Hancock Jr.', written over a horizontal line.

Leonard H. Hancock Jr.
Chief Operations Officer



Quality since 1946

9049 Tyler Blvd. ▪ Mentor, Ohio 44060
Ph. (440) 974-8888 ▪ Fax (440) 974-0165
Toll-Free Fax (800) 841-8003
www.buyersproducts.com

Buyers Products Warranty Policy

Buyers Products warrants all products and hardware manufactured, and/or distributed by it (except those specified) to be free from defects in material and workmanship for a period of two (2) years from date of shipment. Parts must be properly installed and used under normal conditions. Any product which has been altered, including modification, misuse, accident, or lack of maintenance will not be considered under warranty. Normal wear is excluded. The sole responsibility of Buyers Products under this warranty is limited to repairing or replacing any part or part which are returned , prepaid, and are found to be defective by Buyers Products. Authorization from Buyers Products must be obtained before returning any part. No charges for transportation or labor performed on Buyers' products will be allowed under this warranty.

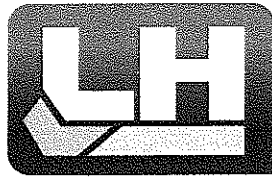

LH JONES
EQUIPMENT

March 22, 2011

State of West Virginia
Department of Administration
Purchasing Division
2019 Washington St. East
PO Box 50130
Charleston, WV 25305-0130

VIA UPS Next Day Air as part of
response to RFQ 7011EC15

RE: RFQ 7011EC15

To Whom It May Concern:

Enclosed you will find the following addenda for the above reference RFQ. No other changes, including price, are made to LH Jones' original response.

Please accept this package as part of LH Jones' response to the RFQ.

LH Jones acknowledges receipt of the following addenda for the RFQ:

Addendum #1
Addendum #2
Addendum #3
Addendum #4

Very truly yours,

Leonard H. Hancock Jr.

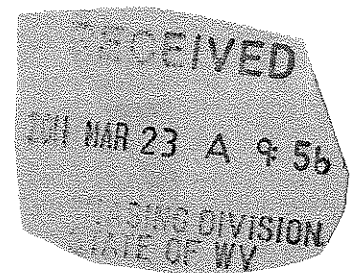



State of West Virginia
 Department of Administration
 Purchasing Division
 2019 Washington Street East
 Post Office Box 50130
 Charleston, WV 25305-0130

Request for Quotation

RFQ NUMBER
7011EC15

PAGE
1

ADDRESS CORRESPONDENCE TO ATTENTION OF
BUYER 33 304-558-2402

VENDOR

*709043957 01 304-292-1307
 L H JONES EQUIP CO
 1825 EARL CORE ROAD
 MORGANTOWN WV 26505

SHIP TO

DIVISION OF HIGHWAYS
 EQUIPMENT DIVISION
 ROUTE 33
 BRUSHY FORK ROAD
 BUCKHANNON, WV
 26201 304-472-1750

DATE PRINTED	TERMS OF SALE	SHIP VIA	F.O.B.	FREIGHT TERMS
02/23/2011				

BID OPENING DATE: 03/15/2011 BID OPENING TIME 01:30PM

LINE	QUANTITY	UOP	CAT NO	ITEM NUMBER	UNIT PRICE	AMOUNT
ADDENDUM NO. 2						
THIS ADDENDUM IS ISSUED TO EXTEND THE BID OPENING DATE FROM 02/23/2011 AT 1:30 PM TO 03/15/2011 AT 1:30 PM						
*****END ADDENDUM NO. 2*****						
0001	1	EA		570-64		
	9 CUBIC YARD			ABRASIVE AND CHEMICAL SPREADER		
***** THIS IS THE END OF RFQ 7011EC15 ***** TOTAL: _____						

No change to original bid package

SEE REVERSE SIDE FOR TERMS AND CONDITIONS			
SIGNATURE <i>[Signature]</i>	TELEPHONE 304 292 1307	DATE 3/22/11	
TITLE <i>CEO</i>	FEIN 55-0551865	ADDRESS CHANGES TO BE NOTED ABOVE	

WHEN RESPONDING TO RFQ, INSERT NAME AND ADDRESS IN SPACE ABOVE LABELED 'VENDOR'



State of West Virginia
 Department of Administration
 Purchasing Division
 2019 Washington Street East
 Post Office Box 50130
 Charleston, WV 25305-0130

Request for Quotation

RFQ NUMBER
7011EC14

PAGE
1

ADDRESS CORRESPONDENCE TO ATTENTION OF:
**BUYER 33
 304-558-2402**

VENDOR

*709043957 01 304-292-1307
 L H JONES EQUIP CO
 1825 EARL CORE ROAD
 MORGANTOWN WV 26505

SHIP TO

DIVISION OF HIGHWAYS
 EQUIPMENT DIVISION
 ROUTE 33
 BRUSHY FORK ROAD
 BUCKHANNON, WV
 26201 304-472-1750

DATE PRINTED 03/10/2011	TERMS OF SALE	SHIP VIA	F.O.B	FREIGHT TERMS
-----------------------------------	---------------	----------	-------	---------------

BID OPENING DATE: **03/23/2011** BID OPENING TIME **01:30PM**

LINE	QUANTITY	UOP	CAT. NO.	ITEM NUMBER	UNIT PRICE	AMOUNT
<p>ADDENDUM NO. 3 THIS ADDENDUM IS ISSUED TO EXTEND THE BID OPENING DATE FROM: 03/15/2011 AT 1:30 PM TO 03/23/2011 AT 1:30 PM *****END ADDENDUM NO. 3*****</p>						
0001	1	LB		570-64		
<p>TO PROVIDE 5 CUBIC YARD STAINLESS STEEL,</p> <p>***** THIS IS THE END OF RFQ 7011EC14 ***** TOTAL: _____</p> <p style="text-align: center;"><i>No change to original bid package.</i></p>						

SEE REVERSE SIDE FOR TERMS AND CONDITIONS

SIGNATURE 	TELEPHONE 304 292 1307	DATE 3/22/11
TITLE COO	FEIN 55-0551865	ADDRESS CHANGES TO BE NOTED ABOVE

WHEN RESPONDING TO RFQ, INSERT NAME AND ADDRESS IN SPACE ABOVE LABELED 'VENDOR'



State of West Virginia
 Department of Administration
 Purchasing Division
 2019 Washington Street East
 Post Office Box 50130
 Charleston, WV 25305-0130

Request for Quotation

RFO NUMBER
7011EC14

PAGE
1

ADDRESS CORRESPONDENCE TO ATTENTION OF
BUYER 33 304-558-2402

VENDOR
*709043957 01 304-292-1307 L H JONES EQUIP CO 1825 EARL CORE ROAD MORGANTOWN WV 26505

SHIP TO
DIVISION OF HIGHWAYS EQUIPMENT DIVISION ROUTE 33 BRUSHY FORK ROAD BUCKHANNON, WV 26201 304-472-1750

DATE PRINTED 03/14/2011	TERMS OF SALE	SHIP VIA	F.O.B.	FREIGHT TERMS
BID OPENING DATE: 03/23/2011		BID OPENING TIME 01:30PM		

LINE	QUANTITY	UOP	CAT NO.	ITEM NUMBER	UNIT PRICE	AMOUNT
				ADDENDUM NO. 4		
				THIS ADDENDUM IS ISSUED TO ADDRESS TECHNICAL QUESTIONS PER THE ATTACED.		
				THE BID OPENING DATE REMAIN 03/23/2011 AT 1:30 PM		
				*****END ADDENDUM NO. 4*****		
0001	1	LB		570-64		
				TO PROVIDE 5 CUBIC YARD STAINLESS STEEL,		
				***** THIS IS THE END OF RFQ 7011EC14 ***** TOTAL:		
				<i>No change to original bid package</i>		

SEE REVERSE SIDE FOR TERMS AND CONDITIONS			
SIGNATURE <i>JH</i>	TELEPHONE 304 292 1307	DATE 3/22/11	
TITLE CCO	FEIN 55-0551865	ADDRESS CHANGES TO BE NOTED ABOVE	

WHEN RESPONDING TO RFQ, INSERT NAME AND ADDRESS IN SPACE ABOVE LABELED 'VENDOR'

ADDENDUM #4
7011EC14

5 CUBIC YARD STAINLESS STEEL
DEMOUNTABLE ABRASIVE AND CHEMICAL SPREADER (HYDRAULIC)

RESPONSE TO QUESTIONS

Pg 15 7.5.12 The conveyor drive motor shall be mounted on the hopper side of the reduction gear box and have a ratio of approximately 50:1. On the last contract, the motors were changed, installed to the rear, so the hoppers could be slid into the dump bodies further.

**RESPONSE: Addressed in the prebid addendum. CHANGED TO READ:
The conveyor drive motor shall be mounted on rear of the reduction gear box and have a ratio of approximately 50-1.**

Pg 28 X7.5.12 Is the conveyor drive motor mounted on hopper side if reduction gear box? On the last contract, we had to change the motor to the rear.

**RESPONSE: Addressed on the prebid addendum. CHANGED TO READ:
X7.5.12 Is conveyor drive motor mounted on rear of the reduction gear box**

YES NO X7.5.12.1 The reduction gear box provides a ratio of 50:1

7.2 Would you accept 201 stainless steel in lieu of 304 stainless steel?

RESPONSE: No

7.4.1 Would you accept 201 stainless steel in lieu of 304 stainless steel?

RESPONSE: No

7.4.7 Would you accept 201 stainless steel in lieu of 304 stainless steel?

RESPONSE: No

7.4.9 Would you accept 201 stainless steel in lieu of 304 stainless steel?

RESPONSE: No

7.4.10 Would you accept 201 stainless steel in lieu of 304 stainless steel?

RESPONSE: No

7.4.11 Would you accept 201 stainless steel in lieu of 304 stainless steel?

RESPONSE: No

7.4.13 Would you accept 201 stainless steel in lieu of 304 stainless steel?

RESPONSE: No

7.5.6 Are the rubber wear strips length wide or are they on the end of the hopper over the chain?

RESPONSEA: Over chain

7.5.7 Would you accept 201 stainless steel in lieu of 304 stainless steel?

RESPONSE: No

7.5.10 Would you accept 201 stainless steel in lieu of 304 stainless steel?

RESPONSE: No

7.5.13 Do you want the speed sensor built in the motor or on the gear box stub shaft?

RESPONSE: In motor

7.10.1 Would you accept 201 stainless steel in lieu of 304 stainless steel?

RESPONSE: No

7.14 Is the angle 4" x 4" x 3/8" x 90" long? **RESPONSE: Yes**

7.4.9 Does "angle formed cross sills" meet this spec? **RESPONSE: No**

7.5.13 I believe that this sentence should end, "integral speed sensor"
RESPONSE: Corrected in addendum #1

7.4.11 I haven't seen any mention of the spreader tie-down/mounting system, such as (4) chains and eye bolts or (4) ratchet straps.
RESPONSE: Tie down not included in specifications

7.4.13 Does the front spill shield have to be delivered mounted or can it be shipped loose inside the spreader?
RESPONSE: May be shipped loose

7.4.15 Does the work light have to be mounted or can it be shipped inside the spreader?
RESPONSE: May be shipped loose

7.5.6 Is a formed stainless steel chain shield acceptable in lieu of the removable rubber chain shield?
RESPONSE: No

7.10 Do the screens and beam have to be mounted or can they be shipped loose inside the spreader?
RESPONSE: May be shipped loose

7.10.1 Is a 6" x 9.0 lb I-beam acceptable in lieu of a box beam?
RESPONSE: No

1. Can you provide an estimate of quantity of units to be purchased in the 12 month period following the date of award?
RESPONSE: Undetermined

2. Will other stainless steel alloys other than 304 be acceptable?
RESPONSE: No

3. What are the desired dimensions for the fold-up ladder?
RESPONSE: Manufacturers standard
4. What are the desired dimensions for the stainless steel grip strut step plate to be mounted on the rear of the spinner housing frame?
RESPONSE: Manufacturers standard
5. Section 7.5.8 while pertaining to the same item on both units is different for the two spreaders. While one is mandatory (14), the other is not (15). Is a 1 ¼" idler shaft acceptable? And, is a 2" drive shaft acceptable? As written, these would be acceptable in the RFQ15 while not in the RFQ14.
RESPONSE: See Addendum #1
6. To comply with the 7.6.4 requirement for bulk unloading is a flip up spinner chute acceptable?
RESPONSE: No it is not – See Addendum #1
7. For top screen mounting, is a 6" channel cross beam acceptable?
RESPONSE: No it is not
8. On RFQ 14 is a 57" spreader height acceptable?
RESPONSE: Must list as exception
9. Is a 6.3 cubic yard capacity acceptable for RFQ14?
RESPONSE: No
11. The lighting drawing shows lights combined in housings but previous spreaders have been supplied with individual weatherproof housing as per the picture below. Are the individual weatherproof housings still allowed?
RESPONSE: As long as you still are in compliance with the spec.



SaltDogg

7, 8, & 9 Cubic Yard Stainless Steel Salt & Sand Spreaders

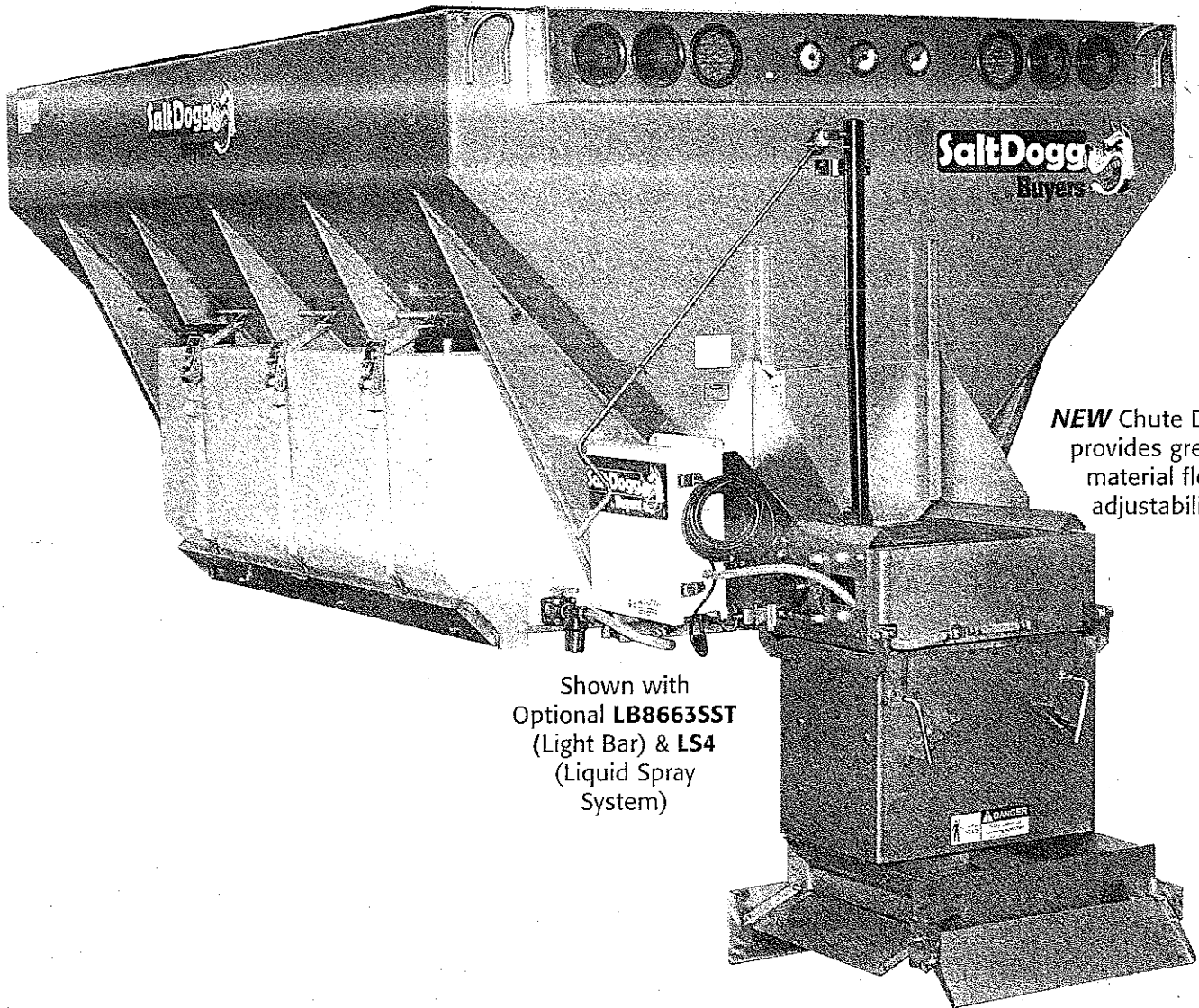

NEW Chute Design provides greater material flow adjustability

Shown with
Optional **LB8663SST**
(Light Bar) & **LS4**
(Liquid Spray
System)

MODEL	DRIVE	GEARBOX RATIO	(LEVEL) CUBIC YARDS	(ROUNDED) CUBIC YARDS	SIDE HEIGHT	EMPTY WEIGHT
1450757SSH	Hydraulic	50:1	7	8.3	57	2,310 lbs.
1425757SSH	Hydraulic	25:1	7	8.3	57	2,310 lbs.
1450863SSH	Hydraulic	50:1	8.3	9.6	63	2,457 lbs.
1425863SSH	Hydraulic	25:1	8.3	9.6	63	2,457 lbs.
1450969SSH	Hydraulic	50:1	9.6	12.2	69	2,550 lbs.
1425969SSH	Hydraulic	25:1	9.6	12.2	69	2,550 lbs.

IDEAL FOR HEAVY-DUTY MUNICIPAL & COMMERCIAL APPLICATIONS

Designed for municipalities and contractors with a minimum 26,000 lbs. GVW chassis.

GENERAL:

- Self-contained hopper.
- Spreads free flowing materials sand and/or salt.
- Spread width of 4' to 40'.

MATERIAL HOPPER:

- 7-gauge 304 stainless steel cross members.
- 10-gauge 304 stainless steel, long sills with rear enclosure & integral chain shields.
- 10-gauge 304 stainless steel replaceable floor.
- 10-gauge 304 stainless steel sides (continuously welded seams), gussets and rear panel.
- 10-gauge 304 stainless steel front panel.
- Four (4) 5/8" thick lift points.

FEEDGATE:

- 10-gauge, 304 stainless steel with scaled screw jack adjustment.
- 18-5/8" wide x 10" tall opening.

CONVEYOR:

- 24" wide, pintle chain conveyor with 3/8" thick x 1-1/2" wide crossbars on 4-1/2" centers (667X Pitch).
- 2" diameter drive shaft with 4-bolt relubeable bearing.
- 8-tooth cast iron sprockets.
- 50:1 or 25:1 direct-drive gearbox with extended through-shaft for ground speed sensor.
- 1-1/2" diameter idler shaft with 4" adjustable range relubeable bearing.
- Conveyor chain wiper made of belted rubber minimizes waste.

STANDARD INSTALLED EQUIPMENT:

- 4-section hinged top grate screens. 3/8" diameter bar on 3" centers with 1/4" x 2" x 2" angle iron frame. Hinged to 6" horizontal crossbeam.
- 10-gauge, 304 stainless steel inverted "V" prevents material compaction and reduces wear on drive train components.

CHUTE/SPINNER ASSEMBLY:

- 10-gauge, 304 stainless steel laser cut parts with smooth radius corners.
- Telescopic adjustment in 3" increments to accommodate varying body mounting heights.

- Two (2) adjustable, internal baffles direct material to 20" diameter x 5/8" thick, 6-fin poly spinner disc.
- Three (3) adjustable external and one (1) fixed deflector with overlapping corners provide a precision spread pattern.
- Top-mounted, direct-drive hydraulic spinner motor provides better ground clearance and corrosion protection.
- Two (2) stainless steel spring latches quick release hinged chute for bulk material-unloading and convenient ground storage.

POWER SOURCE:

- Hydraulic Drive: Two independent direct drive hydraulic motors (17 GPM @ 1,500 PSI).

OPTIONAL EQUIPMENT:

- Dump Body Tailgate Latch Kit (Part # 3008560).
- DOT Spreader Lightbar (Part # LB8663SST). 8" Tall x 66" Long x 3" Deep stainless steel lightbar includes 9 mounting holes for 4" recessed stop-turn-tailights-strobes and 2-1/2" marker lights.
- Liquid Spray System (Part # LS4). Shown below. 104 Gallons.
- Tie-Down Kit (Part # 3010548).

DIMENSIONS:

- Hopper length, 120"; Overall length, 143"; Width, 82"; Recommended use, dump bodies and flat beds with a minimum 26,000 lbs. GVW chassis.

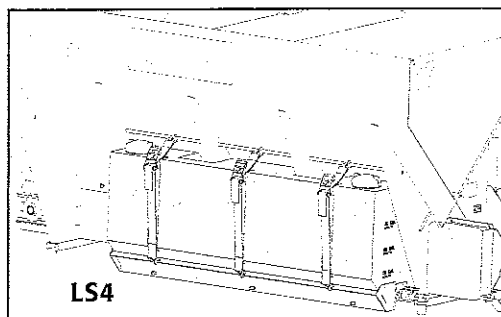

LS4

- Provides more efficient salt distribution
- Speeds the melting process
- Works at lower temperatures than salt
- Residual material on the pavement lasts longer
- Reduces the number of applications required

Contact:



Your Authorized SaltDogg® Distributor

MUNY789LIT0809

State of West Virginia

VENDOR PREFERENCE CERTIFICATE

Certification and application* is hereby made for Preference in accordance with West Virginia Code, §5A-3-37. (Does not apply to construction contracts). West Virginia Code, §5A-3-37, provides an opportunity for qualifying vendors to request (at the time of bid) preference for their residency status. Such preference is an evaluation method only and will be applied only to the cost bid in accordance with the West Virginia Code. This certificate for application is to be used to request such preference. The Purchasing Division will make the determination of the Resident Vendor Preference, if applicable.

- 1. Application is made for 2.5% resident vendor preference for the reason checked: Bidder is an individual resident vendor and has resided continuously in West Virginia for four (4) years immediately preceding the date of this certification; or, Bidder is a partnership, association or corporation resident vendor and has maintained its headquarters or principal place of business continuously in West Virginia for four (4) years immediately preceding the date of this certification; or 80% of the ownership interest of Bidder is held by another individual, partnership, association or corporation resident vendor who has maintained its headquarters or principal place of business continuously in West Virginia for four (4) years immediately preceding the date of this certification; or, Bidder is a nonresident vendor which has an affiliate or subsidiary which employs a minimum of one hundred state residents and which has maintained its headquarters or principal place of business within West Virginia continuously for the four (4) years immediately preceding the date of this certification; or,
2. Application is made for 2.5% resident vendor preference for the reason checked: Bidder is a resident vendor who certifies that, during the life of the contract, on average at least 75% of the employees working on the project being bid are residents of West Virginia who have resided in the state continuously for the two years immediately preceding submission of this bid; or,
3. Application is made for 2.5% resident vendor preference for the reason checked: Bidder is a nonresident vendor employing a minimum of one hundred state residents or is a nonresident vendor with an affiliate or subsidiary which maintains its headquarters or principal place of business within West Virginia employing a minimum of one hundred state residents who certifies that, during the life of the contract, on average at least 75% of the employees or Bidder's affiliate's or subsidiary's employees are residents of West Virginia who have resided in the state continuously for the two years immediately preceding submission of this bid; or,
4. X Application is made for 5% resident vendor preference for the reason checked: Bidder meets either the requirement of both subdivisions (1) and (2) or subdivision (1) and (3) as stated above; or,
5. Application is made for 3.5% resident vendor preference who is a veteran for the reason checked: Bidder is an individual resident vendor who is a veteran of the United States armed forces, the reserves or the National Guard and has resided in West Virginia continuously for the four years immediately preceding the date on which the bid is submitted; or,
6. Application is made for 3.5% resident vendor preference who is a veteran for the reason checked: Bidder is a resident vendor who is a veteran of the United States armed forces, the reserves or the National Guard, if, for purposes of producing or distributing the commodities or completing the project which is the subject of the vendor's bid and continuously over the entire term of the project, on average at least seventy-five percent of the vendor's employees are residents of West Virginia who have resided in the state continuously for the two immediately preceding years.

Bidder understands if the Secretary of Revenue determines that a Bidder receiving preference has failed to continue to meet the requirements for such preference, the Secretary may order the Director of Purchasing to: (a) reject the bid; or (b) assess a penalty against such Bidder in an amount not to exceed 5% of the bid amount and that such penalty will be paid to the contracting agency or deducted from any unpaid balance on the contract or purchase order.

By submission of this certificate, Bidder agrees to disclose any reasonably requested information to the Purchasing Division and authorizes the Department of Revenue to disclose to the Director of Purchasing appropriate information verifying that Bidder has paid the required business taxes, provided that such information does not contain the amounts of taxes paid nor any other information deemed by the Tax Commissioner to be confidential.

Under penalty of law for false swearing (West Virginia Code, §61-5-3), Bidder hereby certifies that this certificate is true and accurate in all respects; and that if a contract is issued to Bidder and if anything contained within this certificate changes during the term of the contract, Bidder will notify the Purchasing Division in writing immediately.

Bidder: LH Jones Equipment Co. Signed: [Signature]
Date: 2/22/11 Title: C.O.O.

*Check any combination of preference consideration(s) indicated above, which you are entitled to receive.

RFQ No. 7011 EC15

STATE OF WEST VIRGINIA
Purchasing Division

PURCHASING AFFIDAVIT

West Virginia Code §5A-3-10a states: No contract or renewal of any contract may be awarded by the state or any of its political subdivisions to any vendor or prospective vendor when the vendor or prospective vendor or a related party to the vendor or prospective vendor is a debtor and the debt owed is an amount greater than one thousand dollars in the aggregate.

DEFINITIONS:

"Debt" means any assessment, premium, penalty, fine, tax or other amount of money owed to the state or any of its political subdivisions because of a judgment, fine, permit violation, license assessment, defaulted workers' compensation premium, penalty or other assessment presently delinquent or due and required to be paid to the state or any of its political subdivisions, including any interest or additional penalties accrued thereon.

"Debtor" means any individual, corporation, partnership, association, limited liability company or any other form or business association owing a debt to the state or any of its political subdivisions. "Political subdivision" means any county commission; municipality; county board of education; any instrumentality established by a county or municipality; any separate corporation or instrumentality established by one or more counties or municipalities, as permitted by law; or any public body charged by law with the performance of a government function or whose jurisdiction is coextensive with one or more counties or municipalities. "Related party" means a party, whether an individual, corporation, partnership, association, limited liability company or any other form or business association or other entity whatsoever, related to any vendor by blood, marriage, ownership or contract through which the party has a relationship of ownership or other interest with the vendor so that the party will actually or by effect receive or control a portion of the benefit, profit or other consideration from performance of a vendor contract with the party receiving an amount that meets or exceeds five percent of the total contract amount.

EXCEPTION: The prohibition of this section does not apply where a vendor has contested any tax administered pursuant to chapter eleven of this code, workers' compensation premium, permit fee or environmental fee or assessment and the matter has not become final or where the vendor has entered into a payment plan or agreement and the vendor is not in default of any of the provisions of such plan or agreement.

Under penalty of law for false swearing (*West Virginia Code §61-5-3*), it is hereby certified that the vendor affirms and acknowledges the information in this affidavit and is in compliance with the requirements as stated.

WITNESS THE FOLLOWING SIGNATURE

Vendor's Name: LH Jones Equipment Co.

Authorized Signature: [Signature] Date: 2/22/11

State of West Virginia

County of Monongalia, to-wit:

Taken, subscribed, and sworn to before me this 22nd day of February, 2011.

My Commission expires October 9, 2018

AFFIX SEAL HERE

NOTARY PUBLIC [Signature]

