



State of West Virginia
 Department of Administration
 Purchasing Division
 2019 Washington Street East
 Post Office Box 50130
 Charleston, WV 25305-0130

Request for Quotation

RFQ NUMBER
7011EC06

PAGE
1

ADDRESS CORRESPONDENCE TO ATTENTION OF:
**BUYER 33
 304-558-2402**

VENDOR

*709054014 304-776-4406
**STATE EQUIPMENT INC
 PO BOX 3939
 CHARLESTON WV 25339**

SHIP TO

**DIVISION OF HIGHWAYS
 EQUIPMENT DIVISION
 ROUTE 33
 BRUSHY FORK ROAD
 BUCKHANNON, WV
 26201 304-472-1750**

DATE PRINTED 09/29/2010	TERMS OF SALE NET 30	SHIP VIA BEST WAY	F.O.B. BUCKHANNON, WV	FREIGHT TERMS PREPAID
-----------------------------------	--------------------------------	-----------------------------	---------------------------------	---------------------------------

BID OPENING DATE: **11/10/2010** BID OPENING TIME **01:30PM**

LINE	QUANTITY	UOP	CAT NO	ITEM NUMBER	UNIT PRICE	AMOUNT
0001	1	EA		760-06	\$94,622.00	\$94,622.00
75 HORSEPOWER TRACTOR/DOZER WITH WINCH AND BLADE OPEN END CONTRACT TO PROVIDE 75 HORSEPOWER TRACTOR/DOZER WITH WINCH AND BLADE FOR THE WEST VIRGINIA DIVISION OF HIGHWAYS. PER THE ATTACHED SPECIFICATIONS. MANDATORY PRE-BID A MANDATORY PRE-BID WILL BE HELD ON THURSDAY, 10/28 AT 11AM, 2019 WASHINGTON ST E., CHARLESTON WV 25305. ALL INTERESTED PARTIES ARE REQUIRED TO ATTEND THIS MEETING FAILURE TO ATTEND THE MANDATORY PRE-BID SHALL RESULT IN DISQUALIFICATION OF THE BID. NO ONE PERSON MAY REPRESENT MORE THAN ONE BIDDER. AN ATTENDANCE SHEET WILL BE MADE AVAILABLE FOR ALL POTENTIAL BIDDERS TO COMPLETE. THIS WILL SERVE AS THE OFFICIAL DOCUMENT VERIFYING ATTENDANCE AT THE MANDATORY PRE-BID. FAILURE TO PROVIDE YOUR COMPANY AND REPRESENTATIVE NAME ON THE ATTENDANCE SHEET WILL RESULT IN DISQUALIFICATION OF THE BID. THE STATE WILL NOT ACCEPT ANY OTHER DOCUMENTATION TO VERIFY ATTENDANCE. THE BIDDER IS RESPONSIBLE FOR ENSURING THEY HAVE COMPLETED THE INFORMATION REQUIRED ON THE ATTENDANCE SHEET. THE PURCHASING DIVISION AND THE STATE AGENCY WILL NOT ASSUME ANY RESPONSIBILITY FOR A BIDDER-S FAILURE TO COMPLETE THE PRE-BID ATTENDANCE SHEET. IN ADDITION, WE REQUEST THAT ALL POTENTIAL BIDDERS INCLUDE THEIR E-MAIL ADDRESS AND FAX NUMBER.						

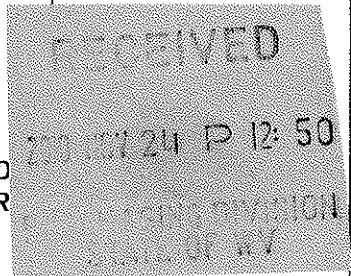

SEE REVERSE SIDE FOR TERMS AND CONDITIONS

SIGNATURE: TELEPHONE: **304-776-4405** DATE: **11/16/2010**

TITLE: **PRESIDENT** FEIN: **550658298** ADDRESS CHANGES TO BE NOTED ABOVE

WHEN RESPONDING TO RFQ, INSERT NAME AND ADDRESS IN SPACE ABOVE LABELED 'VENDOR'

GENERAL TERMS & CONDITIONS
REQUEST FOR QUOTATION (RFQ) AND REQUEST FOR PROPOSAL (RFP)

1. Awards will be made in the best interest of the State of West Virginia.
2. The State may accept or reject in part, or in whole, any bid.
3. Prior to any award, the apparent successful vendor must be properly registered with the Purchasing Division and have paid the required \$125 fee.
4. All services performed or goods delivered under State Purchase Order/Contracts are to be continued for the term of the Purchase Order/Contracts, contingent upon funds being appropriated by the Legislature or otherwise being made available. In the event funds are not appropriated or otherwise available for these services or goods this Purchase Order/Contract becomes void and of no effect after June 30.
5. Payment may only be made after the delivery and acceptance of goods or services.
6. Interest may be paid for late payment in accordance with the *West Virginia Code*.
7. Vendor preference will be granted upon written request in accordance with the *West Virginia Code*.
8. The State of West Virginia is exempt from federal and state taxes and will not pay or reimburse such taxes.
9. The Director of Purchasing may cancel any Purchase Order/Contract upon 30 days written notice to the seller.
10. The laws of the State of West Virginia and the *Legislative Rules* of the Purchasing Division shall govern the purchasing process.
11. Any reference to automatic renewal is hereby deleted. The Contract may be renewed only upon mutual written agreement of the parties.
12. **BANKRUPTCY:** In the event the vendor/contractor files for bankruptcy protection, the State may deem this contract null and void, and terminate such contract without further order.
13. **HIPAA BUSINESS ASSOCIATE ADDENDUM:** The West Virginia State Government HIPAA Business Associate Addendum (BAA), approved by the Attorney General, is available online at www.state.wv.us/admin/purchase/vrc/hipaa.htm and is hereby made part of the agreement. Provided that the Agency meets the definition of a Cover Entity (45 CFR §160.103) and will be disclosing Protected Health Information (45 CFR §160.103) to the vendor.
14. **CONFIDENTIALITY:** The vendor agrees that he or she will not disclose to anyone, directly or indirectly, any such personally identifiable information or other confidential information gained from the agency, unless the individual who is the subject of the information consents to the disclosure in writing or the disclosure is made pursuant to the agency's policies, procedures, and rules. Vendor further agrees to comply with the Confidentiality Policies and Information Security Accountability Requirements, set forth in <http://www.state.wv.us/admin/purchase/privacy/noticeConfidentiality.pdf>.
15. **LICENSING:** Vendors must be licensed and in good standing in accordance with any and all state and local laws and requirements by any state or local agency of West Virginia, including, but not limited to, the West Virginia Secretary of State's Office, the West Virginia Tax Department, and the West Virginia Insurance Commission. The vendor must provide all necessary releases to obtain information to enable the director or spending unit to verify that the vendor is licensed and in good standing with the above entities.
16. **ANTITRUST:** In submitting a bid to any agency for the State of West Virginia, the bidder offers and agrees that if the bid is accepted the bidder will convey, sell, assign or transfer to the State of West Virginia all rights, title and interest in and to all causes of action it may now or hereafter acquire under the antitrust laws of the United States and the State of West Virginia for price fixing and/or unreasonable restraints of trade relating to the particular commodities or services purchased or acquired by the State of West Virginia. Such assignment shall be made and become effective at the time the purchasing agency tenders the initial payment to the bidder.

I certify that this bid is made without prior understanding, agreement, or connection with any corporation, firm, limited liability company, partnership, or person or entity submitting a bid for the same material, supplies, equipment or services and is in all respects fair and without collusion or fraud. I further certify that I am authorized to sign the certification on behalf of the bidder or this bid.

INSTRUCTIONS TO BIDDERS

1. Use the quotation forms provided by the Purchasing Division. Complete all sections of the quotation form.
2. Items offered must be in compliance with the specifications. Any deviation from the specifications must be clearly indicated by the bidder. Alternates offered by the bidder as **EQUAL** to the specifications must be clearly defined. A bidder offering an alternate should attach complete specifications and literature to the bid. The Purchasing Division may waive minor deviations to specifications.
3. Unit prices shall prevail in case of discrepancy. All quotations are considered F.O.B. destination unless alternate shipping terms are clearly identified in the quotation.
4. All quotations must be delivered by the bidder to the office listed below prior to the date and time of the bid opening. Failure of the bidder to deliver the quotations on time will result in bid disqualifications: Department of Administration, Purchasing Division, 2019 Washington Street East, P.O. Box 50130, Charleston, WV 25305-0130
5. Communication during the solicitation, bid, evaluation or award periods, except through the Purchasing Division, is strictly prohibited (W.Va. C.S.R. §148-1-6.6).

GENERAL TERMS & CONDITIONS REQUEST FOR QUOTATION (RFQ) AND REQUEST FOR PROPOSAL (RFP)

1. Awards will be made in the best interest of the State of West Virginia.
 2. The State may accept or reject in part, or in whole, any bid.
 3. Prior to any award, the apparent successful vendor must be properly registered with the Purchasing Division and have paid the required \$125 fee.
 4. All services performed or goods delivered under State Purchase Order/Contracts are to be continued for the term of the Purchase Order/Contracts, contingent upon funds being appropriated by the Legislature or otherwise being made available. In the event funds are not appropriated or otherwise available for these services or goods this Purchase Order/Contract becomes void and of no effect after June 30.
 5. Payment may only be made after the delivery and acceptance of goods or services.
 6. Interest may be paid for late payment in accordance with the *West Virginia Code*.
 7. Vendor preference will be granted upon written request in accordance with the *West Virginia Code*.
 8. The State of West Virginia is exempt from federal and state taxes and will not pay or reimburse such taxes.
 9. The Director of Purchasing may cancel any Purchase Order/Contract upon 30 days written notice to the seller.
 10. The laws of the State of West Virginia and the *Legislative Rules* of the Purchasing Division shall govern the purchasing process.
 11. Any reference to automatic renewal is hereby deleted. The Contract may be renewed only upon mutual written agreement of the parties.
 12. **BANKRUPTCY:** In the event the vendor/contractor files for bankruptcy protection, the State may deem this contract null and void, and terminate such contract without further order.
 13. **HIPAA BUSINESS ASSOCIATE ADDENDUM:** The West Virginia State Government HIPAA Business Associate Addendum (BAA), approved by the Attorney General, is available online at www.state.wv.us/admin/purchase/vrc/hipaa.htm and is hereby made part of the agreement. Provided that the Agency meets the definition of a Cover Entity (45 CFR §160.103) and will be disclosing Protected Health Information (45 CFR §160.103) to the vendor.
 14. **CONFIDENTIALITY:** The vendor agrees that he or she will not disclose to anyone, directly or indirectly, any such personally identifiable information or other confidential information gained from the agency, unless the individual who is the subject of the information consents to the disclosure in writing or the disclosure is made pursuant to the agency's policies, procedures, and rules. Vendor further agrees to comply with the Confidentiality Policies and Information Security Accountability Requirements, set forth in <http://www.state.wv.us/admin/purchase/privacy/noticeConfidentiality.pdf>.
 15. **LICENSING:** Vendors must be licensed and in good standing in accordance with any and all state and local laws and requirements by any state or local agency of West Virginia, including, but not limited to, the West Virginia Secretary of State's Office, the West Virginia Tax Department, and the West Virginia Insurance Commission. The vendor must provide all necessary releases to obtain information to enable the director or spending unit to verify that the vendor is licensed and in good standing with the above entities.
 16. **ANTITRUST:** In submitting a bid to any agency for the State of West Virginia, the bidder offers and agrees that if the bid is accepted the bidder will convey, sell, assign or transfer to the State of West Virginia all rights, title and interest in and to all causes of action it may now or hereafter acquire under the antitrust laws of the United States and the State of West Virginia for price fixing and/or unreasonable restraints of trade relating to the particular commodities or services purchased or acquired by the State of West Virginia. Such assignment shall be made and become effective at the time the purchasing agency tenders the initial payment to the bidder.
- I certify that this bid is made without prior understanding, agreement, or connection with any corporation, firm, limited liability company, partnership, or person or entity submitting a bid for the same material, supplies, equipment or services and is in all respects fair and without collusion or Fraud. I further certify that I am authorized to sign the certification on behalf of the bidder or this bid.

INSTRUCTIONS TO BIDDERS

1. Use the quotation forms provided by the Purchasing Division. Complete all sections of the quotation form.
2. Items offered must be in compliance with the specifications. Any deviation from the specifications must be clearly indicated by the bidder. Alternates offered by the bidder as **EQUAL** to the specifications must be clearly defined. A bidder offering an alternate should attach complete specifications and literature to the bid. The Purchasing Division may waive minor deviations to specifications.
3. Unit prices shall prevail in case of discrepancy. All quotations are considered F.O.B. destination unless alternate shipping terms are clearly identified in the quotation.
4. All quotations must be delivered by the bidder to the office listed below prior to the date and time of the bid opening. Failure of the bidder to deliver the quotations on time will result in bid disqualifications: Department of Administration, Purchasing Division, 2019 Washington Street East, P.O. Box 50130, Charleston, WV 25305-0130
5. Communication during the solicitation, bid, evaluation or award periods, except through the Purchasing Division, is strictly prohibited (W.Va. C.S.R. §148-1-6.6).



State of West Virginia
 Department of Administration
 Purchasing Division
 2019 Washington Street East
 Post Office Box 50130
 Charleston, WV 25305-0130

Request for Quotation

RFQ NUMBER
7011EC06

PAGE
2

ADDRESS CORRESPONDENCE TO ATTENTION OF
BUYER 33 304-558-2402

PROPERTY ROOM

*709054014 304-776-4406
 STATE EQUIPMENT INC
 PO BOX 3939

 CHARLESTON WV 25339

SHIP TO

DIVISION OF HIGHWAYS
 EQUIPMENT DIVISION
 ROUTE 33
 BRUSHY FORK ROAD
 BUCKHANNON, WV
 26201 304-472-1750

DATE PRINTED	TERMS OF SALE	SHIP VIA	F.O.B.	FREIGHT TERMS
09/29/2010	NET 30	BEST WAY	BUCKHANNON, WV	PREPAID
BID OPENING DATE: 11/10/2010		BID OPENING TIME 01:30PM		

LINE	QUANTITY	UOP	CAT NO.	ITEM NUMBER	UNIT PRICE	AMOUNT
<p>ALL POTENTIAL BIDDERS ARE REQUESTED TO ARRIVE PRIOR TO THE STARTING TIME FOR THE PRE-BID. BIDDERS WHO ARRIVE LATE, BUT PRIOR TO THE DISMISSAL OF THE TECHNICAL PORTION OF THE PRE-BID WILL BE PERMITTED TO SIGN IN. BIDDERS WHO ARRIVE AFTER CONCLUSION OF THE TECHNICAL PORTION OF THE PRE-BID, BUT DURING ANY SUBSEQUENT PART OF THE PRE-BID WILL NOT BE PERMITTED TO SIGN THE ATTENDANCE SHEET.</p> <p>QUESTIONS: WRITTEN QUESTIONS WILL BE ACCEPTED THROUGH CLOSE OF BUSINESS (5:00 PM, EST) ON THURSDAY, 10/21/10.</p> <p>SEND QUESTIONS TO: PURCHASING DIVISION ATTENTION SHERI SLONE/CHUCK BOWMAN 2019 WASHINGTON STREET EAST CHARLESTON, WV 25305</p> <p>QUESTIONS MAY BE SENT VIA FAX, E-MAIL, OR REGULAR MAIL. E-MAIL: SHERI.D.SLONE@WV.GOV FAX: 304-558-4115</p> <p>IT IS THE VENDOR'S RESPONSIBILITY TO VERIFY THAT THEIR QUESTIONS HAVE BEEN RECEIVED BY CALLING 304-558-2402.</p> <p>EXHIBIT 2</p> <p>LIFE OF CONTRACT: THIS CONTRACT BECOMES EFFECTIVE ON AND EXTENDS FOR A PERIOD OF ONE (1) YEAR OR UNTIL SUCH "REASONABLE TIME" THEREAFTER AS IS NECESSARY TO OBTAIN A NEW CONTRACT OR RENEW THE ORIGINAL CONTRACT. THE "REASONABLE TIME" PERIOD SHALL NOT EXCEED TWELVE (12) MONTHS. DURING THIS "REASONABLE TIME" THE VENDOR MAY TERMINATE THIS CONTRACT FOR</p>						

SEE REVERSE SIDE FOR TERMS AND CONDITIONS			
SIGNATURE	TELEPHONE	DATE	
	304-776-4405	11/16/2010	
TITLE	FEIN	ADDRESS CHANGES TO BE NOTED ABOVE	
PRESIDENT	550658298		

WHEN RESPONDING TO RFQ, INSERT NAME AND ADDRESS IN SPACE ABOVE LABELED 'VENDOR'



State of West Virginia
 Department of Administration
 Purchasing Division
 2019 Washington Street East
 Post Office Box 50130
 Charleston, WV 25305-0130

Request for Quotation

RFO NUMBER
7011EC06

PAGE
3

ADDRESS CORRESPONDENCE TO ATTENTION OF:
**BUYER 33
 304-558-2402**

***709054014 304-776-4406**
STATE EQUIPMENT INC
PO BOX 3939

CHARLESTON WV 25339

DIVISION OF HIGHWAYS
EQUIPMENT DIVISION
ROUTE 33
BRUSHY FORK ROAD
BUCKHANNON, WV
26201 304-472-1750

DATE PRINTED	TERMS OF SALE	SHIP VIA	F.O.B.	FREIGHT TERMS
09/29/2010	NET 30	BEST WAY	BUCKHANNON, WV	PREPAID

BID OPENING DATE: **11/10/2010** BID OPENING TIME: **01:30PM**

LINE	QUANTITY	UOP	CAT NO	ITEM NUMBER	UNIT PRICE	AMOUNT
<p>ANY REASON UPON GIVING THE DIRECTOR OF PURCHASING THIRTY (30) DAYS WRITTEN NOTICE.</p> <p>UNLESS SPECIFIC PROVISIONS ARE STIPULATED IN THIS CONTRACT DOCUMENT, THE TERMS, CONDITIONS, AND PRICING SET HEREIN ARE FIRM FOR THE LIFE OF THE CONTRACT.</p> <p>RENEWAL: THIS CONTRACT MAY BE RENEWED UPON THE MUTUAL WRITTEN CONSENT OF THE SPENDING UNIT AND VENDOR, SUBMITTED TO THE DIRECTOR OF PURCHASING THIRTY (30) DAYS PRIOR TO THE EXPIRATION DATE. SUCH RENEWAL SHALL BE IN ACCORDANCE WITH THE TERMS AND CONDITIONS OF THE ORIGINAL CONTRACT AND SHALL BE LIMITED TO TWO (2) ONE (1) YEAR PERIODS.</p> <p>CANCELLATION: THE DIRECTOR OF PURCHASING RESERVES THE RIGHT TO CANCEL THIS CONTRACT IMMEDIATELY UPON WRITTEN NOTICE TO THE VENDOR IF THE COMMODITIES AND/OR SERVICE SUPPLIED ARE OF AN INFERIOR QUALITY OR DO NOT CONFORM WITH THE SPECIFICATIONS OF THE BID AND CONTRACT HEREIN.</p> <p>OPEN MARKET CLAUSE: THE DIRECTOR OF PURCHASING MAY AUTHORIZE A SPENDING UNIT TO PURCHASE ON THE OPEN MARKET, WITHOUT THE FILING OF A REQUISITION OR COST ESTIMATE, ITEMS SPECIFIED ON THIS CONTRACT FOR IMMEDIATE DELIVERY IN EMERGENCIES DUE TO UNFORESEEN CAUSES (INCLUDING BUT NOT LIMITED TO DELAYS IN TRANSPORTATION OR AN UNANTICIPATED INCREASE IN THE VOLUME OF WORK).</p> <p>QUANTITIES: QUANTITIES LISTED IN THE REQUISITION ARE APPROXIMATIONS ONLY, BASED ON ESTIMATES SUPPLIES BY THE STATE SPENDING UNIT. IT IS UNDERSTOOD AND AGREED THAT THE CONTRACT SHALL COVER THE QUANTITIES ACTUALLY ORDERED FOR DELIVERY DURING THE TERM OF CONTRACT, WHETHER MORE OR LESS THAN THE QUANTITIES SHOWN.</p>						

SEE REVERSE SIDE FOR TERMS AND CONDITIONS

SIGNATURE	TELEPHONE	DATE
	304-776-4405	11/16/2010
TITLE	FEIN	ADDRESS CHANGES TO BE NOTED ABOVE
PRESIDENT	550658298	

WHEN RESPONDING TO RFQ, INSERT NAME AND ADDRESS IN SPACE ABOVE LABELED 'VENDOR'



State of West Virginia
 Department of Administration
 Purchasing Division
 2019 Washington Street East
 Post Office Box 50130
 Charleston, WV 25305-0130

Request for Quotation

REQ NUMBER
7011EC06

PAGE
4

ADDRESS CORRESPONDENCE TO ATTENTION OF
BUYER 33
304-558-2402

VENDOR

*709054014 304-776-4406
 STATE EQUIPMENT INC
 PO BOX 3939

 CHARLESTON WV 25339

SHIP TO

DIVISION OF HIGHWAYS
 EQUIPMENT DIVISION
 ROUTE 33
 BRUSHY FORK ROAD
 BUCKHANNON, WV
 26201 304-472-1750

DATE PRINTED	TERMS OF SALE	SHIP VIA	F.O.B.	FREIGHT TERMS
09/29/2010	NET 30	BEST WAY	BUCKHANNON, WV	PREPAID

BID OPENING DATE: **11/10/2010** BID OPENING TIME **01:30PM**

LINE	QUANTITY	UOP	CAT NO	ITEM NUMBER	UNIT PRICE	AMOUNT
<p>ORDERING PROCEDURE: SPENDING UNIT(S) SHALL ISSUE A WRITTEN EQUIPMENT CONTRACT ORDER (FORM NUMBER WV-35) FOR COMMODITIES COVERED BY THIS CONTRACT. THE ORIGINAL WV-35 MUST BE SENT TO THE PURCHASING DIVISION OF THE DEPARTMENT OF ADMINISTRATION. AFTER APPROVAL AND ENCUMBRANCE, ONE COPY OF THE PURCHASE ORDER WILL BE RETURNED TO THE SPENDING UNIT AND ONE COPY FORWARDED TO THE VENDOR AS AUTHORIZATION FOR SHIPMENT. NO ORDER IS VALID UNLESS APPROVED AND ENCUMBERED BY THE PURCHASING DIVISION.</p> <p>BANKRUPTCY: IN THE EVENT THE VENDOR/CONTRACTOR FILES FOR BANKRUPTCY PROTECTION, THE STATE MAY DEEM THE CONTRACT NULL AND VOID, AND TERMINATE SUCH CONTRACT WITHOUT FUTHER ORDER.</p> <p>REV. 5/2009</p> <p>EXHIBIT 10</p> <p style="text-align: center;">REQUISITION NO.: .7011EC06</p> <p>ADDENDUM ACKNOWLEDGEMENT</p> <p>I HEREBY ACKNOWLEDGE RECEIPT OF THE FOLLOWING CHECKED ADDENDUM(S) AND HAVE MADE THE NECESSARY REVISIONS TO MY PROPOSAL, PLANS AND/OR SPECIFICATION, ETC.</p> <p>ADDENDUM NO.'S:</p> <p>NO. 1 <i>[Signature]</i></p> <p>NO. 2 <i>[Signature]</i></p> <p>NO. 3 <i>[Signature]</i></p>						

SEE REVERSE SIDE FOR TERMS AND CONDITIONS

SIGNATURE <i>[Signature]</i>	TELEPHONE 304-776-4405	DATE 11/16/2010
TITLE PRESIDENT	FEIN 550658298	ADDRESS CHANGES TO BE NOTED ABOVE

WHEN RESPONDING TO RFQ, INSERT NAME AND ADDRESS IN SPACE ABOVE LABELED 'VENDOR'



State of West Virginia
 Department of Administration
 Purchasing Division
 2019 Washington Street East
 Post Office Box 50130
 Charleston, WV 25305-0130

Request for Quotation

RFQ NUMBER
7011EC06

PAGE
5

ADDRESS CORRESPONDENCE TO ATTENTION OF
BUYER 33 304-558-2402

VENDOR

*709054014 304-776-4406
 STATE EQUIPMENT INC
 PO BOX 3939
 CHARLESTON WV 25339

SHIP TO

DIVISION OF HIGHWAYS
 EQUIPMENT DIVISION
 ROUTE 33
 BRUSHY FORK ROAD
 BUCKHANNON, WV
 26201 304-472-1750

DATE PRINTED	TERMS OF SALE	SHIP VIA	FOB	FREIGHT TERMS
09/29/2010	NET 30	BEST WAY	BUCKHANNON, WV	PREPAID

BID OPENING DATE: 11/10/2010 BID OPENING TIME 01:30PM

LINE	QUANTITY	UOP	CAT NO.	ITEM NUMBER	UNIT PRICE	AMOUNT
NO. 4						
NO. 5						
<p>I UNDERSTAND THAT FAILURE TO CONFIRM THE RECEIPT OF TH ADDENDUM(S) MAY BE CAUSE FOR REJECTION OF BIDS.</p> <p>VENDOR MUST CLEARLY UNDERSTAND THAT ANY VERBAL REPRESENTATION MADE OR ASSUMED TO BE MADE DURING ANY ORAL DISCUSSION HELD BETWEEN VENDOR'S REPRESENTATIVES AND ANY STATE PERSONNEL IS NOT BINDING. ONLY THE INFORMATION ISSUED IN WRITING AND ADDED TO THE SPECIFICATIONS BY AN OFFICIAL ADDENDUM IS BINDING.</p> <p style="text-align: center;">..... SIGNATURE STATE EQUIPMENT, INC. COMPANY 11/16/2010 DATE</p> <p>NOTE: THIS ADDENDUM ACKNOWLEDGEMENT SHOULD BE SUBMITTED WITH THE BID.</p> <p>REV. 09/21/2009</p> <p>EXHIBIT 4</p> <p>LOCAL GOVERNMENT BODIES: UNLESS THE VENDOR INDICATES IN THE BID HIS REFUSAL TO EXTEND THE PRICES, TERMS, AND CONDITIONS OF THE BID TO COUNTY, SCHOOL, MUNICIPAL</p>						

SEE REVERSE SIDE FOR TERMS AND CONDITIONS

SIGNATURE	TELEPHONE	DATE
	304-776-4405	11/16/2010
TITLE	FEIN	ADDRESS CHANGES TO BE NOTED ABOVE
PRESIDENT	550658298	

WHEN RESPONDING TO RFQ, INSERT NAME AND ADDRESS IN SPACE ABOVE LABELED 'VENDOR'



State of West Virginia
 Department of Administration
 Purchasing Division
 2019 Washington Street East
 Post Office Box 50130
 Charleston, WV 25305-0130

Request for Quotation

RFO NUMBER
7011EC06

PAGE
7

ADDRESS CORRESPONDENCE TO ATTENTION OF
**BUYER 33
 304-558-2402**

VENDOR

*709054014 304-776-4406
 STATE EQUIPMENT INC
 PO BOX 3939
 CHARLESTON WV 25339

SHIP TO

DIVISION OF HIGHWAYS
 EQUIPMENT DIVISION
 ROUTE 33
 BRUSHY FORK ROAD
 BUCKHANNON, WV
 26201 304-472-1750

DATE PRINTED	TERMS OF SALE	SHIP VIA	F.O.B	FREIGHT TERMS
09/29/2010	NET 30	BEST WAY	BUCKHANNON, WV	PREPAID

BID OPENING DATE: **11/10/2010** BID OPENING TIME: **01:30PM**

LINE	QUANTITY	UOP	CAT NO	ITEM NUMBER	UNIT PRICE	AMOUNT
BID OPENING TIME: 1:30 PM PLEASE PROVIDE A FAX NUMBER IN CASE IT IS NECESSARY TO CONTACT YOU REGARDING YOUR BID: -----304-776-4409----- CONTACT PERSON (PLEASE PRINT CLEARLY): -----EDDIE ROWAN, JR.-----						
***** THIS IS THE END OF RFQ 7011EC06 ***** TOTAL:						<u>\$94,622.00</u>

SEE REVERSE SIDE FOR TERMS AND CONDITIONS

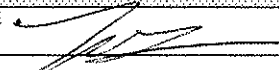
SIGNATURE 	TELEPHONE 304-776-4405	DATE 11/16/2010
TITLE PRESIDENT	FEIN 550658298	ADDRESS CHANGES TO BE NOTED ABOVE

WHEN RESPONDING TO RFQ, INSERT NAME AND ADDRESS IN SPACE ABOVE LABELED 'VENDOR'

WEST VIRGINIA DEPARTMENT OF TRANSPORTATION
DIVISION OF HIGHWAYS
EQUIPMENT DIVISION

PROCUREMENT SPECIFICATIONS
NO. 300-2-D

OPEN END CONTRACT
75 HORSEPOWER TRACTOR/DOZER WITH WINCH AND BLADE

1.0 PURPOSE

It is the purpose of these specifications to describe a 75 Horsepower Tractor/Dozer with Winch and Blade (hereinafter referred to as a "dozer" or a "unit") to be purchased for use by the West Virginia Division of Highways (DOH) on an Open End Contract basis.

2.0 BIDDING PROCEDURES

The current purchasing procedures regarding bidding as established by the Department of Administration, Purchasing Division, shall apply. Failure to submit the "Request for Quotation" forms, complete in its entirety and according to directions indicated, may subject the bidder to disqualification. Each bid submitted shall also be accompanied by a Bidder's Evaluation Report completed in detail. Addendums in order, along with exception sheets, should be with Bidder's Evaluation Report. **FAILURE TO SUBMIT THE BIDDER'S EVALUATION REPORT, COMPLETE IN ITS ENTIRETY, SHALL RESULT IN AUTOMATIC DISQUALIFICATION.**

3.0 SPECIFICATIONS

The specifications named herein, mandatory and non-mandatory, establish the acceptable level of quality only and are not intended to reflect a preference or favor any particular brand or vendor.

3.1 EXCEPTIONS TO NON-MANDATORY SPECIFICATIONS

Exception to a non-mandatory unit specification may be made by the bidder, providing the exception is not available from the manufacturer. **Any such exception must be noted on the bidder's evaluation report and should be accompanied by supporting documentation/literature from the manufacturer. Any exception must be indicated on a separate attachment to the bidder's evaluation report and labeled as "Exception to Specifications".** The state reserves the right to determine whether the stated exception does or does not reduce the quality and performance of the unit. Failure to provide information for any exceptions may be grounds for rejection of the bid. The state reserves the right to waive minor irregularities in bids or specifications in accordance with §148-1-4(f) of the WV Legislative Rules and Regulations.

3.2 MANDATORY SPECIFICATIONS

All specifications preceded by "shall, will, and/or must" or are stated as a "minimum and/or maximum" are mandatory as stated in Purchasing Divisions Policies and Procedures. Any bid failing to meet any mandatory item shall be immediately disqualified. Failure to respond in the appropriate evaluation section may also be grounds for immediate disqualification at the discretion of the State.

A mandatory pre-bid conference is scheduled for this equipment purchase as stated in the RFQ. Vendors having products with variations or exceptions in specified mandatory items are expected to address any such variations or exceptions during the pre-bid conference. The State shall review and consider any such variation or exception, and may at its sole discretion, issue an addendum to change mandatory specifications deemed to be in the State's best interest. Bids from any vendor failing to attend the mandatory pre-bid shall be disqualified. Bids containing any variation or exception to a mandatory specification that was not addressed during the pre-bid conference and accepted by the issuance of an Addendum shall be disqualified.

4.0 REPRESENTATIVE UNIT FOR TEST

The successful vendor must (if specified) provide DOH one (1) completed representative unit to be observed and evaluated on each order to insure compliance with specification. If requested, the time period for testing and evaluation shall be seven (7) working days following receipt of the unit. DOH will incur no obligation for deterioration of surfaces, finishes, seals, and mechanical or electrical parts on the unit resulting from operation and testing within the limits of these specifications; nor will DOH incur obligation for damage to the unit resulting from failure to meet specifications when due care and attention is given by DOH and testing is done within the limits of these specifications. Failure of the pilot unit to satisfactorily meet specifications as bid shall be cause for cancellation of the purchase order, and return of the delivered unit along with all associated equipment to the vendor at the vendor's expense.

4.1 CONDITION OF UNIT(S) UPON DELIVERY

All units must arrive at the prescribed delivery point having been completely preserviced with oil, lubricants, and coolant. All prescribed precautions pertaining to first operations and break-in of the unit are to be posted conspicuously on the unit for ready observance by the operator.

4.2 DELIVERY

Delivery point of the completely assembled representative unit will be the DOH, Equipment Division, Route 33 at Brushy Fork Road, Buckhannon, West Virginia (26201).

The vendor is responsible for guaranteeing delivery of the completed units within the time specified and agreed to by the State. Delivery is preferred within 120 days after receipt of purchase agreement. The vendor is responsible for establishing and coordinating delivery terms with allied manufacturers or suppliers. Delivery terms shall be stated in the bid and the State reserves the right to accept or negotiate such

terms. Failure to reach an agreement may result in rejection of the bid. **The successful bidder shall provide their manufacturer's confirmation of the order to the WVDOH contact person within seven (7) working days after receiving the approved purchase order.**

A completed pilot model for inspection must be provided within 90 calendar days after receipt of the purchase agreement by the successful vendor.

Delivery is an integral part of this specification and failure to comply will be cause to initiate a D.O.T. Administrative Form WV-82, Vendor Performance Form. The WV-82 Form will provide a means of officially notifying the Purchasing Division and the vendor of unsatisfactory performance; such as late deliveries, poor service, inadequate parts supplies, etc.

The decision to initiate subject Form will be at the sole discretion of the D.O.H. Commissioner's established Equipment Review Board.

Issuance of the WV-82 Vendor Complaint Form on unsatisfactory delivery against any vendor will be cause to refuse to consider similar items from those vendors on future Request For Quotations.

(NOTE: Delivery time could be altered due to labor strikes, severe inclement weather conditions, etc.)

5.0 AWARD CRITERIA

- 5.1 DOH will recommend the award in accordance with the RFQ evaluation criteria described in the requisition. **The award shall be made to the lowest unit cost vendor that meets or exceeds the specifications.** DOH reserves the right to place multiple orders in any quantity.

6.0 SPECIFICATIONS AND GUIDELINES - GENERAL

6.1 IDENTIFICATION OF THE UNIT BEING PROPOSED

The bidder must identify the unit by manufacturer, model, series, and year of manufacture, in the bid to enable identification by DOH in the manufacturer's specifications of the proposed unit. The bidder will submit complete descriptive literature of the proposed unit, to establish that the bid is the manufacturer's most current model, including latest engineering improvements, which have been, or will imminently be, regularly advertised and sold on the open market. The unit specified herein and offered to be manufactured after January 1, 2010 and be clearly identified and marked with date of manufacture.

6.2 OPERATING AND SERVICE MANUALS AND PARTS LISTS

An operator's manual must be included with each unit upon delivery. A "line sheet" (if applicable) and Equipment Preventative Maintenance Questionnaire (as shown in X6.2 of the Bidder's Evaluation Report) must be with pilot unit upon delivery. In addition, there must be 12 service, shop, or maintenance manuals; ten (10) to be distributed to the Districts and two (2) for the Equipment Division.

Also, there must be 14 parts manuals; ten (10) to be distributed to the Districts and four (4) for Equipment Division use. CD ROM is preferred in lieu of parts or service manuals.

* NOTE: MANUALS SHALL BE DELIVERED UPON COMPLETION OF DELIVERY OF TOTAL UNITS. FAILURE TO DO SO WILL DELAY PAYMENT.

6.3 TRAINING:

Manufacturers and/or dealers will be required to stage a thorough seminar on the subjects of Preventative Maintenance, Operator and Mechanic Training. In order to keep the operators and mechanics updated, the successful vendor shall conduct training with each purchase order against this open end contract. Training is preferred within 2 working days after delivery of the pilot unit on the individual purchase order.

Manufacturers and/or dealers shall be required to furnish the Training Academy with one (1) Operator's Manual to be shipped direct to WVDOH Training Academy, Post Office Box 610, Buckhannon, West Virginia 26201 prior to delivery of the pilot.

The seminar to be held at the W. Va. Division of Highways, Equipment Division, Buckhannon, West Virginia.

6.4 PREVENTIVE MAINTENANCE AND OPERATOR PROCEDURES:

Manufacturers and/or dealers will be required to submit to the Equipment Division, in addition to the operating and service manuals, booklets and pamphlets explaining the Preventive Maintenance and Operator Procedures to be used by the operators of this equipment, and must include such things as daily prestart inspection procedure, service schedule, and routine maintenance required, safety precautions, etc.

The successful vendor shall furnish all training aids; i.e., videos, projectors, etc. required in conducting the training.

6.5 WARRANTY AND SERVICE POLICY

The Manufacturers warranty or service policy is to apply to the unit. Such warranty or service policy is to be recognized at any authorized unit dealer, representing manufacturer of proposed unit throughout the State of West Virginia. The applicable warranty or service policy will not be contingent upon obtaining routine service, lubrication, and servicing of the unit from factory authorized agencies. It will be the responsibility of the bidder to have available labor to repair or replace any defective replacement parts, components and materials, and to have available those replacement parts, components, and/or materials found to be defective during the terms of the warranty period. The bidder should state the labor rates, locations where parts will be stocked, availability of parts, and discounts offered for parts, when terms of the warranty offer a pro-rated cost for parts and labor. In addition, the successful bidder should offer field work to repair or replace defective parts, components, and materials found to be

defective during the terms of the warranty and should provide mechanic's travel rates, mileage charges, field mechanic rates, and any surcharge for miscellaneous items, if applicable, for field work during the warranty period. Submit to Division of Highways any technical or engineering improvements during the term of the warranty. The unit must be accompanied upon delivery by the unit's manufacturer's executed warranty or service policy.

A mandatory minimum two (2) year bumper to bumper basic parts and labor warranty excluding abuse and normal wear items is required for this unit.

THE "WARRANTY AND SERVICE POLICY QUESTIONNAIRE" ATTACHED IN THE BIDDER'S EVALUATION REPORT MUST BE COMPLETED IN ITS ENTIRETY BY THE SUCCESSFUL BIDDER OR MANUFACTURER PRIOR TO DELIVERY OF THE PILOT MODEL. (SEE SECTION X6.5 OF BIDDER'S EVALUATION REPORT).

6.6 EVALUATION COMMITTEE REQUIREMENTS

Detailed component specifications, product literature, component models, required for specification compliance determination by the Evaluation Committee should be provided with each bid. Any information supplied that is contrary to/or conflicting with the specifications and/or attached Bidders Evaluation Report may be sufficient cause for rejection of bid.

6.7 UNSPECIFIED ACCESSORIES & FEATURES

All parts, equipment, accessories, material, design and performance characteristics not specified herein, but which are necessary to provide a complete unit, must be furnished with each unit and required to conform to strength, quality of material, and quality of workmanship to those which are advertised and provided to the market in general by the unit industry.

All parts and accessories advertised and regularly supplied as standard shall be included, except those which would represent duplication of these specified, and except those which, by specification, are not to be furnished. All standard safety features, required by Federal and State Law, shall be included.

7.0 SPECIFICATIONS OF THE QUOTED UNIT ARE AS FOLLOWS:

7.1 Engine:

7.1.1 Engine shall be diesel

7.1.2 Engine to be approximately 75 horsepower

- 7.1.3 Engine flywheel power to be approximately 70 horsepower
- 7.2 Weight:
 - 7.2.1 Operating weight shall be minimum 15,000 lbs. to maximum 21,000 lbs.
- 7.3 Transmission:
 - 7.3.1 Travel speed – forward: Approximately 5.6 MPH/ 9KM/h
 - 7.3.2 Travel speed – reverse: Approximately 6 MPH/9.6KM/h
- 7.4 Cab/ROPS/FOPS:
 - 7.4.1 Unit shall have fully enclosed cab with air conditioning, ROPS, FOPS, and rear screen
 - 7.4.1.1 ROPS – Must meet SAE J397-Oct 95, SAFJ1040 May 94, ISO 3471-94, ISO 3164-95 Standards
 - 7.4.1.2 FOPS – Must meet SAEJ231 – Jan 81, ISO 3449-Standards
- 7.5 Winch:
 - 7.5.1 Winch shall be hydrostatic with variable control
 - 7.5.2 Drum capacity should be about 257 feet
 - 7.5.2.1 Winch rope diameter shall be a minimum of 5/8 inches and maximum 3/4 inches with tail chain and hook. (Must comply with winch specifications.)
 - 7.5.3 Minimum line pull (full drum) 25,000 lbs/11340kg
 - 7.5.4 Maximum line speed (full drum) 207 feet/min/ 63m/min.
 - 7.5.5 Winch shall meet or exceed all OSHA safety requirements
- 7.6 Undercarriage:
 - 7.6.1 Shoe width – 16 inches / 406 mm
 - 7.6.2 Unit shall have standard rock guards on each end
- 7.7 Blade:
 - 7.7.1 Unit shall have a 6-way blade.

7.8 Paint:

7.8.1 **The dozer shall be painted manufacturer's standard**

7.8.2 In order to test the adhesive quality of the paint, the DOH may, at its option, require that the vendor measure adhesion by the criteria set forth in ASTM D3359-74, Method B. A rating of less than 4 on this test would be deemed unacceptable.

7.8.3 The procedures used by the manufacturer in cleaning, de-greasing, priming, and painting are sufficient to meet this requirement.

7.8.4 The Department reserves the right to view larger paint samples after award of contract and the right to require subtle color changes. Such changes, if any, will only be used for selecting a suitable paint color to match the WV DOH logo.

7.9 **Vendor must certify that unit offered will meet or exceed the "Occupational Safety and Health Act of 1970" or subsequent changes that are in effect at time of manufacturer of the unit.**

7.10 **Advertising: Only one (1) manufacturer name plate, which must include model number, may appear on exterior of unit. Logos created through the stamping or casting process of manufacture are also acceptable. No logo will interfere with the Department's striping and logo.**

7.11 Preventive Maintenance and Operators Orientation/Training:

7.11.1 **The Manufacturer or dealer shall provide preventive maintenance/operator orientation seminar to be conducted at the Equipment Division, Buckhannon. All training aids i.e. videos, charts, manuals, etc., to be furnished by successful vendor.**



State of West Virginia
 Department of Administration
 Purchasing Division
 2019 Washington Street East
 Post Office Box 50130
 Charleston, WV 25305-0130

WV PURCHASING AGENCY SECTION Request for Quotation
 Fax 304-558-4115 Oct 15 2010 05:12pm P001/002
 RFQ NUMBER: 7011EC06

ADDRESS CORRESPONDENCE TO ATTENTION OF:
 BUYER 33
 304-558-2402

RFQ COPY
 TYPE NAME/ADDRESS HERE

DIVISION OF HIGHWAYS
 EQUIPMENT DIVISION
 ROUTE 33
 BRUSHY FORK ROAD
 BUCKHANNON, WV
 26201 304-472-1750

DATE PRINTED	TERMS OF SALE	SHIP VIA	FOB	FREIGHT TERMS
10/15/2010	NET 30	BEST WAY	BUCKHANNON, WV	PREPAID

LINE	QUANTITY	UOP	CAT NO	ITEM NUMBER	BID OPENING TIME	UNIT PRICE	AMOUNT
ADDENDUM NO. 1 THIS ADDENDUM IS ISSUED TO: 1.) TO CHANGE THE DATE AND TIME FOR THE MANDATORY PRE-BID MEETING, MANDATORY PRE-BID DATE: 11/03/2010 MANDATORY PRE-BID TIME: 9:00 AM PRE-BID WILL BE HELD AT: WV STATE PURCHASING DIVISION 2019 WASHINGTON STREET, EAST CHARLESTON, WV 25305 (BUILDING #15) 2.) TO EXTEND THE DEADLINE FOR TECHNICAL QUESTIONS, DEADLINE FOR TECHNICAL QUESTIONS: 10/28/2010 AT THE CLOSE OF BUSINESS (5:00 PM) 3.) EXTEND THE BID OPENING DATE BID OPENING DATE IS EXTENDED TO: 11/17/2010 BID OPENING TIME REMAINS: 1:30 PM ***** END ADDENDUM NO. 1 *****							

SEE REVERSE SIDE FOR TERMS AND CONDITIONS

SIGNATURE: *[Signature]* TITLE: PRESIDENT
 TELEPHONE: 304-776-4405 FEIN: 550658298
 DATE: 11/16/2010 ADDRESS CHANGES TO BE NOTED ABOVE

WHEN RESPONDING TO RFQ, INSERT NAME AND ADDRESS IN SPACE ABOVE LABELED 'VENDOR'

GENERAL TERMS & CONDITIONS REQUEST FOR QUOTATION (RFQ) AND REQUEST FOR PROPOSAL (RFP)

1. Awards will be made in the best interest of the State of West Virginia.
 2. The State may accept or reject in part, or in whole, any bid.
 3. Prior to any award, the apparent successful vendor must be properly registered with the Purchasing Division and have paid the required \$125 fee.
 4. All services performed or goods delivered under State Purchase Order/Contracts are to be continued for the term of the Purchase Order/Contracts, contingent upon funds being appropriated by the Legislature or otherwise being made available. In the event funds are not appropriated or otherwise available for these services or goods this Purchase Order/Contract becomes void and of no effect after June 30.
 5. Payment may only be made after the delivery and acceptance of goods or services.
 6. Interest may be paid for late payment in accordance with the *West Virginia Code*.
 7. Vendor preference will be granted upon written request in accordance with the *West Virginia Code*.
 8. The State of West Virginia is exempt from federal and state taxes and will not pay or reimburse such taxes.
 9. The Director of Purchasing may cancel any Purchase Order/Contract upon 30 days written notice to the seller.
 10. The laws of the State of West Virginia and the *Legislative Rules* of the Purchasing Division shall govern the purchasing process.
 11. Any reference to automatic renewal is hereby deleted. The Contract may be renewed only upon mutual written agreement of the parties.
 12. **BANKRUPTCY:** In the event the vendor/contractor files for bankruptcy protection, the State may deem this contract null and void, and terminate such contract without further order.
 13. **HIPAA BUSINESS ASSOCIATE ADDENDUM:** The West Virginia State Government HIPAA Business Associate Addendum (BAA), approved by the Attorney General, is available online at www.state.wv.us/admin/purchase/vrc/hipaa.htm and is hereby made part of the agreement. Provided that the Agency meets the definition of a Cover Entity (45 CFR §160.103) and will be disclosing Protected Health Information (45 CFR §160.103) to the vendor.
 14. **CONFIDENTIALITY:** The vendor agrees that he or she will not disclose to anyone, directly or indirectly, any such personally identifiable information or other confidential information gained from the agency, unless the individual who is the subject of the information consents to the disclosure in writing or the disclosure is made pursuant to the agency's policies, procedures, and rules. Vendor further agrees to comply with the Confidentiality Policies and Information Security Accountability Requirements, set forth in <http://www.state.wv.us/admin/purchase/privacy/noticeConfidentiality.pdf>.
 15. **LICENSING:** Vendors must be licensed and in good standing in accordance with any and all state and local laws and requirements by any state or local agency of West Virginia, including, but not limited to, the West Virginia Secretary of State's Office, the West Virginia Tax Department, and the West Virginia Insurance Commission. The vendor must provide all necessary releases to obtain information to enable the director or spending unit to verify that the vendor is licensed and in good standing with the above entities.
 16. **ANTITRUST:** In submitting a bid to any agency for the State of West Virginia, the bidder offers and agrees that if the bid is accepted the bidder will convey, sell, assign or transfer to the State of West Virginia all rights, title and interest in and to all causes of action it may now or hereafter acquire under the antitrust laws of the United States and the State of West Virginia for price fixing and/or unreasonable restraints of trade relating to the particular commodities or services purchased or acquired by the State of West Virginia. Such assignment shall be made and become effective at the time the purchasing agency tenders the initial payment to the bidder.
- I certify that this bid is made without prior understanding, agreement, or connection with any corporation, firm, limited liability company, partnership, or person or entity submitting a bid for the same material, supplies, equipment or services and is in all respects fair and without collusion or fraud. I further certify that I am authorized to sign the certification on behalf of the bidder or this bid.

INSTRUCTIONS TO BIDDERS

1. Use the quotation forms provided by the Purchasing Division. Complete all sections of the quotation form.
2. Items offered must be in compliance with the specifications. Any deviation from the specifications must be clearly indicated by the bidder. Alternates offered by the bidder as **EQUAL** to the specifications must be clearly defined. A bidder offering an alternate should attach complete specifications and literature to the bid. The Purchasing Division may waive minor deviations to specifications.
3. Unit prices shall prevail in case of discrepancy. All quotations are considered F.O.B. destination unless alternate shipping terms are clearly identified in the quotation.
4. All quotations must be delivered by the bidder to the office listed below prior to the date and time of the bid opening. Failure of the bidder to deliver the quotations on time will result in bid disqualifications: Department of Administration, Purchasing Division, 2019 Washington Street East, P.O. Box 50130, Charleston, WV 25305-0130
5. Communication during the solicitation, bid, evaluation or award periods, except through the Purchasing Division, is strictly prohibited (W.Va. C.S.R. §148-1-6.6).



State of West Virginia
 Department of Administration
 Purchasing Division
 2019 Washington Street East
 Post Office Box 50130
 Charleston, WV 25305-0130

Request for
Quotation

REQ NUMBER	PAGE
7011EC06	1
ADDRESS CORRESPONDENCE TO ATTENTION OF	
BUYER 33 304-558-2402	

709054014 304-776-4406
 STATE EQUIPMENT INC
 PO BOX 3939
 CHARLESTON WV 25339

DIVISION OF HIGHWAYS
 EQUIPMENT DIVISION
 ROUTE 33
 BRUSHY FORK ROAD
 BUCKHANNON, WV
 26201 304-472-1750

DATE PRINTED	TERMS OF SALE	SHIP VIA	FOB	FREIGHT TERMS
11/16/2010	NET 30	BEST WAY	BUCKHANNON, WV	PREPAID

LINE	QUANTITY	UOF	CAT NO	ITEM NUMBER	UNIT PRICE	AMOUNT
------	----------	-----	--------	-------------	------------	--------

ADDENDUM NO. 2

THIS ADDENDUM IS ISSUED TO ADDRESS SPECIFICATION CHANGES AS DISCUSSED AND AGREED UPON DURING MANDATORY PRE-BID MEETING PER ATTACHED.

BID OPENING DATE REMAINS: 11/17/2010
 BID OPENING TIME REMAINS: 1:30 PM

***** END ADDENDUM NO. 2 *****

0001	EA		760-06			
	1			CASE 650L DOZER WITH WINCH	\$94,622.00	\$94,622.00
				75 HORSEPOWER TRACTOR/DOZER WITH WINCH AND BLADE		

***** THIS IS THE END OF RFQ 7011EC06 ***** TOTAL: \$94,622.00

SIGNATURE		SEE REVERSE SIDE FOR TERMS AND CONDITIONS		TELEPHONE	DATE
				304-776-4405	11/16/2010
TITLE	FEIN	ADDRESS CHANGES TO BE NOTED ABOVE			
PRESIDENT	550658298				

WHEN RESPONDING TO RFQ, INSERT NAME AND ADDRESS IN SPACE ABOVE LABELED 'VENDOR'



State of West Virginia
 Department of Administration
 Purchasing Division
 2019 Washington Street East
 Post Office Box 50130
 Charleston, WV 25305-0130

WV PURCHASING ACA SECT Fax 304-558-4115

Nov 16 2010 02:55pm P001/001

**request for
 Quotation**

RFQ NUMBER
 7011EC06

PAGE
 1

ADDRESS CORRESPONDENCE TO ATTENTION OF
 BUYER 33
 304-558-2402

*709054014 304-776-4406
 STATE EQUIPMENT INC
 PO BOX 3939
 CHARLESTON WV 25339

DIVISION OF HIGHWAYS
 EQUIPMENT DIVISION
 ROUTE 33
 BRUSHY FORK ROAD
 BUCKHANNON, WV
 26201 304-472-1750

DATE PRINTED	TERMS OF SALE	SHIP VIA	FOB	FREIGHT TERMS
11/16/2010	NET 30	BEST WAY	BUCKHANNON, WV	PREPAID

BID OPENING DATE: 11/24/2010 BID OPENING TIME: 01:30PM

LINE	QUANTITY	UOP	CAT NO	ITEM NUMBER	UNIT PRICE	AMOUNT
ADDENDUM NO. 3						
THIS ADDENDUM IS ISSUED TO:						
EXTEND BID OPENING DATE: 11/24/2010						
EXTEND BID OPENING TIME: 1:30 PM						
*****END ADDENDUM NO 3*****						
0001	EA			750-06		
	1			CASE 650L DOZER WITH WINCH	\$94,622.00	\$94,622.00
	75			HORSEPOWER TRACTOR/DOZER WITH WINCH AND BLADE		
***** THIS IS THE END OF RFQ 7011EC06 ***** TOTAL:						\$94,622.00

SEE REVERSE SIDE FOR TERMS AND CONDITIONS

SIGNATURE _____ TELEPHONE 304-776-4405 DATE 11/16/2010
 TITLE PRESIDENT FEIN 550658298 ADDRESS CHANGES TO BE NOTED ABOVE

WHEN RESPONDING TO RFQ, INSERT NAME AND ADDRESS IN SPACE ABOVE LABELED 'VENDOR'



State of West Virginia
 Department of Administration
 Purchasing Division
 2019 Washington Street East
 Post Office Box 50130
 Charleston, WV 25305-0130

Request for Quotation

RFQ NUMBER:
7011EC06

PAGE:
1

ADDRESS CORRESPONDENCE TO ATTENTION OF:
 BUYER 33
 304-558-2402

VENDOR:
 709054014 304-776-4406
 STATE EQUIPMENT INC
 PO BOX 3939
 CHARLESTON WV 25339

DIVISION OF HIGHWAYS
 EQUIPMENT DIVISION
 ROUTE 33
 BRUSHY FORK ROAD
 BUCKHANNON, WV
 26201 304-472-1750

DATE PRINTED	TERMS OF SALE	SHIP VIA	FOB	FREIGHT TERMS
11/22/2010	NET 30	BEST WAY	BUCKHANNON, WV	PREPAID

BID OPENING DATE: 11/24/2010 BID OPENING TIME 01:30PM

LINE	QUANTITY	UOP	CAT NO	ITEM NUMBER	UNIT PRICE	AMOUNT
ADDENDUM NO 4						
THIS ADDENDUM IS ISSUED TO ADDRESS CORRECTION TO ITEM 7.5.4 OF SPECIFICATION, PER ATTACHED.						
*****END ADDENDUM NO 4*****						
0001		EA		760-06		
	1			CASE 650L DOZER WITH WINCH	\$94,622.00	\$94,622.00
				75 HORSEPOWER TRACTOR/DOZER WITH WINCH AND BLADE		
***** THIS IS THE END OF RFQ 7011EC06 ***** TOTAL:						\$94,622.00

SEE REVERSE SIDE FOR TERMS AND CONDITIONS

SIGNATURE:  TELEPHONE: 304-776-4405 DATE: 11/16/2010
 TITLE: PRESIDENT FEIN: 550658298 ADDRESS CHANGES TO BE NOTED ABOVE

WHEN RESPONDING TO RFQ, INSERT NAME AND ADDRESS IN SPACE ABOVE LABELED 'VENDOR'

PREBID ADDENDUM #2

70-11-EC06

OPEN END CONTRACT

75 HORSEPOWER TRACTOR/DOZER WITH WINCH AND BLADE

CHANGES TO SPECIFICATIONS:

FROM:

4.2 DELIVERY – 2nd Paragraph – 2nd Sentence
Delivery is preferred within 120 days after receipt of purchase agreement.

TO:

4.2 DELIVERY – 2nd Paragraph – 2nd Sentence
Delivery is preferred within 180 days after receipt of purchase agreement.

FROM:

4.2 DELIVERY – 3rd Paragraph
A completed pilot model for inspection must be provided within 90 calendar days after receipt of the purchase agreement by the successful vendor.

TO:

4.2 DELIVERY – 3rd Paragraph
A completed pilot model for inspection must be provided within 120 calendar days after receipt of the purchase agreement by the successful vendor.

FROM:

7.5.2 Drum capacity should be about 257 feet.

TO:

7.5.2 Drum capacity should be about 257 feet. **However we will spool only 150 feet.**

FROM:

7.5.2.1 **Winch rope diameter shall be a minimum of 5/8 inches and maximum 3/4 inches with tail chain and hook. (Must comply with winch specifications.)**

TO:

7.5.2.1 **Winch rope diameter shall be a minimum of 5/8 inch cable with tail chain and hook. (Must comply with winch specifications.)**

Prebid Addendum
7011EC06

FROM:

7.5.3 **Minimum line pull (full drum) 25,000 lbs./11340kg.**

TO:

7.5.3 **Minimum line pull (full drum) 22,000 lbs.**

FROM:

7.5.4 **Maximum line speed (full drum) 207 feet/min/63m/min.**

TO:

7.5.4 **Minimum line speed (full drum) 100 ft. per minute**

DELETE: (Duplicate)

7.11 Preventive Maintenance and Operators Orientation/Training:

7.11.1 **The Manufacturer or dealer shall provide preventive maintenance/operator orientation seminar to be conducted at the Equipment Division, Buckhannon. All training aids i.e. videos, charts, manuals, etc. to be furnished by successful vendor.**

PREBID ADDENDUM #4
70-11-EC06

OPEN END CONTRACT
75 HORSEPOWER TRACTOR/DOZER WITH WINCH AND BLADE

CHANGES TO SPECIFICATIONS:

FROM PREBID ADDENDUM #2

7.5.4 Minimum line speed (full drum) 100 ft. per minute

TO:

7.5.4 Minimum line speed (full drum) 80 ft. per minute

WEST VIRGINIA DEPARTMENT OF TRANSPORTATION
DIVISION OF HIGHWAYS
EQUIPMENT DIVISION

BIDDER'S EVALUATION REPORT

PROCUREMENT SPECIFICATIONS FOR OPEN END CONTRACT
NO. 300-2-D

OPEN END CONTRACT
75 HORSEPOWER TRACTOR/DOZER WITH WINCH AND BLADE

NOTE TO BIDDER: Procurement Specification No. 300-2-D, Paragraph 2.0 recommends the completion and submittal of this Report with your bid. Purpose of this Report is to enable the West Virginia Division of Highways Evaluation Committee to make full and fair evaluation of the bid. Addendums in order, along with a summary of exception as a separate attachment, should be with Bidder's Evaluation Report. FAILURE TO SUBMIT THIS REPORT, COMPLETE IN ITS ENTIRETY, MAY SUBJECT THE BIDDER TO DISQUALIFICATION.

Reference Requisition No.: 7011EC06

Bidder's Name: STATE EQUIPMENT, INC

Address: P.O. BOX 3939 CHARLESTON, WV 25339

Telephone Number: 304-776-4405

Years Bidder has been registered to do business with the State of West Virginia: 25 YRS.

Years Company has been an authorized dealer for proposed unit: 25 YRS.

X3.2 Have you complied with all mandatory specifications? YES NO

X4.2 DELIVERY:

X4.2.1 Delivery date of completed representative unit: 120 Calendar Days After
Receipt of Purchase Agreement

X4.2.2 Delivery date of balance of completed units: 180 Calendar Days After Receipt of
Purchase Agreement

NOTE: Vendor should type Bidder's Evaluation Report

The "Bid Schedule" is available for download on Purchasing's Web site at
www.state.wv.us/admin/purchase

X5.0 AWARD CRITERIA;

X5.1 Price per unit:

\$94,622.00 per unit

X6.0 SPECIFICATIONS - GENERAL

X6.1 Manufacturer, model, series, and date of manufacture of proposed unit:

2010 CASE 650L

Is descriptive literature, fully describing proposed unit attached to your bid? YES NO

If not, why? _____

X6.2 Will the required number of service manuals, and complete parts list be delivered to the Equipment Division at Buckhannon upon completion of delivery of total units?

YES NO

Will the required Equipment Preventive Maintenance Form (Section X6.2 of Bidders Evaluation Report) be provided upon inspection of the pilot unit? YES NO

X6.2
2-10-00

EQUIPMENT PREVENTATIVE MAINTENANCE QUESTIONNAIRE

THIS FORM MUST BE COMPLETED IN ITS ENTIRETY BY SUCCESSFUL BIDDER OR MANUFACTURER'S TECHNICAL REPRESENTATIVE PRIOR TO DELIVERY OF PILOT MODEL TO THE WVDOH.

DESCRIPTION: _____ MAKE: _____

MODEL: _____ YEAR: _____ PURCHASE AMOUNT: _____

ENGINE: MAKE: _____ MODEL: _____ FUEL TYPE: _____

HORSEPOWER: _____ CYLINDER: _____ ENGINE SERIAL: _____

COOLING SYSTEM CAPACITY: _____

BELTS: DESCRIPTION: _____ PART NUMBERS: _____

GVW: _____ AXLE CAPACITY: FRONT: _____ REAR: _____

TIRES: FRONT MAKE & SIZE: _____

REAR MAKE & SIZE: _____

DIMENSIONS OF UNIT: LENGTH: _____ WIDTH: _____ LENGTH: _____

VENDOR CONTACT PERSON: _____ PHONE: _____

PARTS:

BATTERY MAKE: _____ MODEL: _____ CCA: _____

TOP OR SIDE POST: _____ DIMENSIONS: LENGTH _____ WIDTH _____ HEIGHT _____

SPARK PLUGS OR FUEL INJECTORS MAKE: _____ PART #: _____

FUEL PUMP OR INJECTION PUMP MAKE: _____ MODEL: _____

ALTERNATOR MAKE: _____ PART #: _____

STARTER MAKE: _____ PART #: _____

TURBO CHARGER MAKE: _____ PART #: _____

TRANS. MAKE: _____ MODEL: _____ AUTO/MANUAL: _____

HYDRAULIC PUMP MAKE: _____ MODEL: _____

FILTERS	MAKE	PART NO.	LUBRICANT	MANUFACTURER TYPE
OIL	_____	_____	ENGINE	_____
AIR INNER	_____	_____	TRANSMISSION	_____
AIR OUTER	_____	_____	POWER STEERING	_____
FUEL PRIMARY	_____	_____	HYDRAULIC	_____
FUEL SECONDARY	_____	_____	DIFFERENTIALS	_____
COOLANT	_____	_____	BRAKE FLUID	_____
HYDRAULIC	_____	_____	COOLANT	_____
OTHER	_____	_____	OTHER	_____

X6.3 TRAINING:

Will training seminar be conducted on Preventive Maintenance, Operator and Mechanic Training YES NO

Will you conduct training with each purchase order against this open end contract? YES NO

Will training be conducted within 2 working days from the delivery of the pilot unit on the individual purchase order? YES NO

If NO, explain time frame _____

Will an Operator's Manual be furnished directly to Training Academy prior to the delivery of the pilot? YES NO

X6.4 If you are the successful vendor, will you furnish all training aids, i.e., videos, projectors, required in conducting the training? YES NO

X6.4.1 Will all manuals, booklets, etc. explaining preventive maintenance, operator procedures, and service schedule be delivered with each unit? YES NO

If NO, explain _____

X6.5 WARRANTY AND SERVICE POLICY

Will the warranty and service you provide comply with all areas as stated in Section 6.5 of specifications YES NO

Is warranty literature attached? YES NO

Is a minimum two (2) year bumper to bumper basic parts and labor warranty excluding abuse and normal wear items included? YES NO

Describe:

SEE ATTACHED _____

2 YEAR OR 2,000 HOUR WHICHEVER OCCURS FIRST. _____

X6.5 WARRANTY AND SERVICE POLICY QUESTIONNAIRE
THIS FORM MUST BE COMPLETED IN ITS ENTIRETY AND SUBMITTED WITH YOUR BID.

(If additional lines are needed, make copies of form.)

1. Define the terms of the standard warranty. If not offered, so state. (Attach copy)

TWELVE MONTHS UNLIMITED HOURS

TWENTY FOUR MONTHS OR 2,000 HOURS ON CASE ENGINE

SEE ATTACHED

2. Define warranty service to be performed at DOH facilities and warranty service to be performed at manufacturer's representative facility. List name and location of manufacturer's representative.

WARRANTY, SERVICE TO BE PERFORMED AT STATE EQUIPMENT, INC. FACILITIES

CROSS LANES, WV BRIDGEPORT, WV PARKERSBURG, WV BECKLEY, WV

3. List locations for parts inventories that are within the State of West Virginia. Also, list availability levels, if known.

CROSS LANES, WV

BECKLEY, WV

BRIDGEPORT, WV

PARKERSBURG, WV

4. During the term of warranty, list the guarantee discount to manufacturer's published list price for parts that bidder will sell the parts to owner.

A. Terms: Net 30 Manufacturer's published list price less: 0 % discount

B. Terms: Net 60 Manufacturer's published list price less: 0 % discount

C. Terms: Net 90 Manufacturer's published list price less: 0 % discount

5. During the term of warranty, will all manufacturers or engineering improvements be submitted to Division of Highways? X YES NO

6. During the term of warranty, list the guaranteed rates charged for repair to the unit.

A. Shop Rate \$ 90.00 per mechanic hour

B. Travel Time Charge \$ 90.00 per mechanic hour
 (Specify if one-way) X ; port to port X

C. Mileage Charge \$ 1.25 per vehicle mile
 (Specify if one-way) X ; port to port X

D. Field Mechanic Rate \$ 90.00 per mechanic hour

E. Specify period of time that prices are in effect: 12 MONTHS

F. Surcharge for miscellaneous items: 0 %

X6.6 EVALUATION COMMITTEE REQUIREMENTS

Is all component specifications, product literature, component models provided for Evaluation Committee bid determination? YES NO

X6.7 Will all parts, equipment, accessories, material, design and performance characteristics not specified herein, but which are necessary to provide a complete unit, be furnished with the unit and conform in strength, quality of material, and quality of workmanship to those which are advertised and provided to the market in general by the unit industry? YES NO

X6.7.1 Are all parts and accessories adequate and regularly supplied as standard to be included except those which may be duplications of specifications herein, and except these by specification are not to be furnished? YES NO

X6.7.2 Are all standard safety features that are required by Federal and State statutes of law included? YES NO

X7.0 SPECIFICATIONS OF THE QUOTED UNIT:

The bidder should complete the following schedule in order for the Division to compare the actual bid unit to the specifications. Should the bidder except a requirement, then such exception may be only on the basis that such feature is not offered by the manufacturer. The Division will have the sole discretion as to whether the bidder's substitution meets the requirements of the specification.

Manufacturer: CASE Model: 650L

X7.1 Engine:

X7.1.1 Is engine diesel YES NO

X7.1.2 Engine horsepower: 80.5

X7.1.3 Engine flywheel power: 74 HP

X7.2 Weight:

X7.2.1 Operating weight: 20,156 lbs.

PREBID ADDENDUM #2
70-11-EC06

OPEN END CONTRACT
75 HORSEPOWER TRACTOR/DOZER WITH WINCH AND BLADE

CHANGES TO BIDDER'S EVALUATION REPORT:

NO CHANGE REQUIRED:

X4.2 DELIVERY:

X4.2.1 Delivery date of completed representative unit: 120 Calendar Days After
Receipt of Purchase Agreement

X4.2.2 Delivery date of balance of completed units: 180 Calendar Days After Receipt of
Purchase Agreement

FROM:

X7.5.2 Drum Capacity: feet

TO:

X7.5.2 Drum Capacity: 277 feet How many feet spooled: 150 feet

FROM:

X7.5.2.1 Winch rope diameter inches with tail chain and hook YES NO
Does it comply with winch specifications YES NO

TO:

X7.5.2.1 Winch rope diameter 5/8 inch cable with tail chain and hook
 x YES NO
Does it comply with winch specifications x YES NO

FROM:

X7.5.3 Minimum line pull (full drum): lbs./ kg.

TO:

X7.5.3 Minimum line pull (full drum) 22,000 lbs.

7011EC06
Bidder's Evaluation

FROM:

X7.5.4 Maximum line speed (full drum): _____ feet/min _____ m/min.

TO:

X7.5.4 Minimum line speed (full drum): 80 ft. per minute

DELETE: (Duplicate)

X7.11 Preventive Maintenance and Operators Orientation/Training:

X7.11.1 Will manufacturer or dealer conduct seminar at Buckhannon YES NO

X7.11.2 Will you furnish all training aids YES NO

X7.3 Transmission:

X7.3.1 Travel speed forward: 0 - 5.5 MPH/ _____ KM/hX7.3.2 Travel speed reverse: 0 - 5.5 MPH/ _____ KM/h

X7.4 Cab/ROPS/FOPS:

XD7.4.1 Does unit have fully enclosed cab with air conditioning, ROPS, FOPS, and rear screen X YES _____ NOX7.4.1.1 Does ROPS meet SAE J397-Oct. 95, SAFJ1040 May 94, ISO3471-94 ISO 3164-95 Standards X YES _____ NOX7.4.1.2 Does FOPS meet SAEJ231-Jan.81, ISO 3449 Standards X YES _____ NO

X7.5 Winch:

X7.5.1 Is winch hydrostatic with variable control X YES _____ NOX7.5.2 Drum Capacity: 277 feetX7.5.2.1 Winch rope diameter 5/8 inches with tail chain and hook X YES _____ NODoes it comply with winch specifications X YES _____ NOX7.5.3 Minimum line pull (full drum): 22,000 lbs./ _____ kgX7.5.4 Maximum line speed (full drum): 184 feet/min _____ m/minX7.5.5 Does winch meet or exceed all OSHA safety requirements X YES _____ NO

X7.6 Undercarriage:

X7.6.1 Shoe width: 16 inches/ _____ mmX7.6.2 Does unit have standard rock guards on each end X YES _____ NO

X7.7 Blade:

X7.7.1 Does unit have a 6 way blade X YES _____ NO

X7.8 Paint (Describe proposed method of painting and color):

COLOR,CASE POWER TAN - POWDER COATING METHOD

X7.9 Does unit comply with OSHA requirements YES NO

X7.10 Does unit comply with advertising guidelines YES NO

X7.11 Preventive Maintenance and Operators Orientation/Training:

X7.11.1 Will manufacturer or dealer conduct seminar at Buckhannon YES NO

X7.11.2 Will you furnish all training aids YES NO

State of West Virginia

VENDOR PREFERENCE CERTIFICATE

Certification and application* is hereby made for Preference in accordance with West Virginia Code, §5A-3-37. (Does not apply to construction contracts). West Virginia Code, §5A-3-37, provides an opportunity for qualifying vendors to request (at the time of bid) preference for their residency status. Such preference is an evaluation method only and will be applied only to the cost bid in accordance with the West Virginia Code. This certificate for application is to be used to request such preference. The Purchasing Division will make the determination of the Resident Vendor Preference, if applicable.

- 1. Application is made for 2.5% resident vendor preference for the reason checked: Bidder is an individual resident vendor and has resided continuously in West Virginia for four (4) years immediately preceding the date of this certification; or, X Bidder is a partnership, association or corporation resident vendor and has maintained its headquarters or principal place of business continuously in West Virginia for four (4) years immediately preceding the date of this certification; or 80% of the ownership interest of Bidder is held by another individual, partnership, association or corporation resident vendor who has maintained its headquarters or principal place of business continuously in West Virginia for four (4) years immediately preceding the date of this certification; or, Bidder is a nonresident vendor which has an affiliate or subsidiary which employs a minimum of one hundred state residents and which has maintained its headquarters or principal place of business within West Virginia continuously for the four (4) years immediately preceding the date of this certification; or,
2. Application is made for 2.5% resident vendor preference for the reason checked: Bidder is a resident vendor who certifies that, during the life of the contract, on average at least 75% of the employees working on the project being bid are residents of West Virginia who have resided in the state continuously for the two years immediately preceding submission of this bid; or,
3. Application is made for 2.5% resident vendor preference for the reason checked: Bidder is a nonresident vendor employing a minimum of one hundred state residents or is a nonresident vendor with an affiliate or subsidiary which maintains its headquarters or principal place of business within West Virginia employing a minimum of one hundred state residents who certifies that, during the life of the contract, on average at least 75% of the employees or Bidder's affiliate's or subsidiary's employees are residents of West Virginia who have resided in the state continuously for the two years immediately preceding submission of this bid; or,
4. Application is made for 5% resident vendor preference for the reason checked: Bidder meets either the requirement of both subdivisions (1) and (2) or subdivision (1) and (3) as stated above; or,
5. Application is made for 3.5% resident vendor preference who is a veteran for the reason checked: Bidder is an individual resident vendor who is a veteran of the United States armed forces, the reserves or the National Guard and has resided in West Virginia continuously for the four years immediately preceding the date on which the bid is submitted; or,
6. Application is made for 3.5% resident vendor preference who is a veteran for the reason checked: Bidder is a resident vendor who is a veteran of the United States armed forces, the reserves or the National Guard, if, for purposes of producing or distributing the commodities or completing the project which is the subject of the vendor's bid and continuously over the entire term of the project, on average at least seventy-five percent of the vendor's employees are residents of West Virginia who have resided in the state continuously for the two immediately preceding years.

Bidder understands if the Secretary of Revenue determines that a Bidder receiving preference has failed to continue to meet the requirements for such preference, the Secretary may order the Director of Purchasing to: (a) reject the bid; or (b) assess a penalty against such Bidder in an amount not to exceed 5% of the bid amount and that such penalty will be paid to the contracting agency or deducted from any unpaid balance on the contract or purchase order.

By submission of this certificate, Bidder agrees to disclose any reasonably requested information to the Purchasing Division and authorizes the Department of Revenue to disclose to the Director of Purchasing appropriate information verifying that Bidder has paid the required business taxes, provided that such information does not contain the amounts of taxes paid nor any other information deemed by the Tax Commissioner to be confidential.

Under penalty of law for false swearing (West Virginia Code, §61-5-3), Bidder hereby certifies that this certificate is true and accurate in all respects; and that if a contract is issued to Bidder and if anything contained within this certificate changes during the term of the contract, Bidder will notify the Purchasing Division in writing immediately.

Bidder: STATE EQUIPMENT, INC.

Signed: [Signature]

Date: 11/16/2010

Title: PRESIDENT

*Check any combination of preference consideration(s) indicated above, which you are entitled to receive.

RFQ No. 7011EC06

STATE OF WEST VIRGINIA
Purchasing Division

PURCHASING AFFIDAVIT

West Virginia Code §5A-3-10a states: No contract or renewal of any contract may be awarded by the state or any of its political subdivisions to any vendor or prospective vendor when the vendor or prospective vendor or a related party to the vendor or prospective vendor is a debtor and the debt owned is an amount greater than one thousand dollars in the aggregate

DEFINITIONS:

"Debt" means any assessment, premium, penalty, fine, tax or other amount of money owed to the state or any of its political subdivisions because of a judgment, fine, permit violation, license assessment, defaulted workers' compensation premium, penalty or other assessment presently delinquent or due and required to be paid to the state or any of its political subdivisions, including any interest or additional penalties accrued thereon.

"Debtor" means any individual, corporation, partnership, association, Limited Liability Company or any other form or business association owing a debt to the state or any of its political subdivisions. "Political subdivision" means any county commission; municipality; county board of education; any instrumentality established by a county or municipality; any separate corporation or instrumentality established by one or more counties or municipalities, as permitted by law; or any public body charged by law with the performance of a government function or whose jurisdiction is coextensive with one or more counties or municipalities. "Related party" means a party, whether an individual, corporation, partnership, association, limited liability company or any other form or business association or other entity whatsoever, related to any vendor by blood, marriage, ownership or contract through which the party has a relationship of ownership or other interest with the vendor so that the party will actually or by effect receive or control a portion of the benefit, profit or other consideration from performance of a vendor contract with the party receiving an amount that meets or exceeds five percent of the total contract amount.

EXCEPTION: The prohibition of this section does not apply where a vendor has contested any tax administered pursuant to chapter eleven of this code, workers' compensation premium, permit fee or environmental fee or assessment and the matter has not become final or where the vendor has entered into a payment plan or agreement and the vendor is not in default of any of the provisions of such plan or agreement.

Under penalty of law for false swearing (*West Virginia Code §61-5-3*), it is hereby certified that the vendor affirms and acknowledges the information in this affidavit and is in compliance with the requirements as stated.

WITNESS THE FOLLOWING SIGNATURE

Vendor's Name: STATE EQUIPMENT, INC.

Authorized Signature: [Signature] Date: 11/16/2010

State of West Virginia

County of Kanawha to-wit:

Taken, subscribed, and sworn to before me this 22nd day of November, 2010.

My Commission expires March 27, 2011.

AFFIX SEAL HERE

NOTARY PUBLIC [Signature: Marie Eiler]

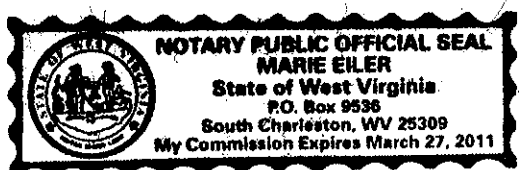

PRELIMINARY

ENGINE

Model	
Case Family IV 445TA/EHA diesel, Tier 3 certified	
EPA Family NHTL04.5DCB	
Cylinders	4
Bore/Stroke	4.1 in x 5.2 in (104 x 132 mm)
Displacement	274 in ³ (4.5 L)
Fuel injection	Direct
Fuel	#2 Diesel
Fuel filter	Spin-on with in-line strainer
Air intake	Cross-flow
Cooling	Liquid
Engine speeds (rpm)	
High idle - no load	2160±50
Rated - full load	2000
Low idle	850-950
Horsepower per SAE J1349	
Net	74 (55 kW) @ 2000 rpm
Gross	80.5 (60 kW) @ 2000 rpm
Peak torque @ 1400 rpm	
Net	289 lb-ft (355 N-m)
Gross	295 lb-ft (363 N-m)
Engine lubrication -	
Pump	Deep sump plate cooler with pressurized under-piston nozzles
Pump operating angle ratings -	
Side-to-side	45°
Fore and aft	45°
Oil filtration	Replaceable, spin-on full-flow cartridge

ENGINE COOLING

Radiator -	
Core size area	357.5 m ² (2306 cm ²)
Rows of tubes	1
Fan -	
Diameter	20 in (500 mm)
Ratio	1.1:1

ELECTRICAL SYSTEM

Alternator	65 amp 95 amp w/A/C
Battery	12-volt low-maintenance 700 cold-cranking amps @ 0° F (-18 C)

POWERTRAIN

Dual path hydrostatic	
Pump - variable axial piston	
Motor - variable bent axis piston	
Maximum drawbar pull*	36,000 lb (160.5 kN)
Transmission	Single lever control - electronic straight tracking
Transmission oil filter	4 micron, spin-on replaceable
Travel speeds* -	
Forward	0-5.5 mph (0-9 km/h)
Reverse	0-5.5 mph (0-9 km/h)
*Measured using standard track chain. Increase travel speeds by 4% and reduce drawbar pull by 4% with the optional CELT track chain.	
Parking brakes	Heavy-duty, spring-applied, hydraulic pressure release
Steering brakes	Hydrostatic
Final drive	2 helical gear reduction to planetary output
Ratio	61:1

TRANSMISSION COOLING

Type	Oil to air
Core size	225.7 in ² (1456 cm ²)

HYDRAULIC SYSTEM

Standard equipment pump	
Pump flow @ 2000 rpm @ 3000 psi (209 kPa)	20.3 gpm (78.8 L/min)
Max. system pressure	3025±75 psi (20 855±515 kPa)

CYLINDERS

Lift cylinder (2)	
Bore diameter	3.50 in (89 mm)
Rod diameter	1.75 in (44.5 mm)
Stroke	13.5 in (342 mm)
Angle cylinder (2)	
Bore diameter	3.50 in (89 mm)
Rod diameter	1.75 in (44.5 mm)
Stroke	15.5 in (394 mm)
Tilt cylinder (1)	
Bore diameter	3.50 in (89 mm)
Rod diameter	1.75 in (44.5 mm)
Stroke	5.4 in (137 mm)

UNDERCARRIAGE

Track adjustment	Hydraulic
Frame	Rigid suspension
Length of track on ground (CLT)	84 in (2141 mm)
Track link pitch	6.29 in (160 mm)
Track shoe height	2.06 in (52 mm)
Pin diameter	1.13 in (29 mm)
Bushing diameter -	
CLT track	2.125 in (54 mm)
CELT track	2.75 in (70 mm)
Bolt diameter	0.625 in (16 mm)
Track shoes per side	39
Track rollers per side	6
Carrier rollers per side	1
Track roller rail dia.	6.1 in (155 mm)

TRACK ON GROUND

Shoe	Area - in ² (cm ²)
16 in (406 mm)	2630 (16 968)
20 in (508 mm)	3372 (21 755)
27 in (686 mm)	4552 (29 368)

TRACK

Long Track	
16 in (406 mm) closed grousers and CLT	
16 in (406 mm) open grousers and CELT	
Wide Track	
16 in (406 mm) closed grousers and CLT	
16 in (406 mm) open grousers and CELT	
20 in (508 mm) closed grousers and CLT	
20 in (508 mm) open grousers and CELT	
LGP	
27 in (686 mm) closed grousers and CLT	
27 in (686 mm) open grousers and CELT	

OPERATOR ENVIRONMENT

ROPS canopy
Single lever control for speed, steering and direction
Forward/reverse speed ratio selector
Adjustable armrests
Foot rests
Retractable seat belt, 2 in (51 mm)
Vinyl suspension seat w/back adjustment
Rear view mirror

INSTRUMENTATION

Warning lights:
Air filter
Alternator
Engine oil pressure
Hi range
Hydraulic filter
Transmission filter
Transmission pressure
Gauges:
Battery voltage
Fuel level
Hourmeter
Tachometer
Transmission oil temperature
Water temperature
Audible warnings:
Engine oil pressure
Transmission pressure

BLADE

Variable blade pitch	52°-60°
Lift speed (per second)	19.7 in (500 mm)
Cutting edge	Reversible and replaceable
Width	8.0 in (203 mm)
Thickness	0.625 in (16 mm)

RIPPER

Max. penetration	8.7 in (221 mm)
Width	72.4 in (1839 mm)
Cut width	70.1 in (1780 mm)
Max. ground clearance	15.5 in (393 mm)
Points	Replaceable
Max. number of shanks	5
Tooth spacing –	
with 3 teeth	31 in (785 mm)
Hydraulic cylinder (double-acting)	
Diameter	3.2 in (82 mm)
Stroke	8.4 in (213 mm)
Rod	1.75 in (44.5 mm)

SERVICE CAPACITIES

Fuel tank	41 gal (155 L)
Engine oil w/filter	13 qt (12.3 L)
Engine oil w/o filter	12.2 qt (11.5 L)
Engine cooling system	22.6 qt (21.4 L)
Hydraulic reservoir	16.5 gal (72.7 L)
Final drive (per side)	15 qt (14.2 L)
Track rollers (ea.)	0.19 qt (0.18 L)
Front idlers (ea.)	0.42 qt (0.40 L)
Carrier rollers (ea.)	0.25 qt (0.24 L)

OPERATING WEIGHTS

Unit equipped with ROPS, full fuel tank, 170 lb (77 kg) operator, track guides, backup alarm, horn and lights.	
Long track (96 in blade, 16 in shoe)	16,250 lb (7370 kg)
Wide track (112 in blade, 20 in shoe)	16,800 lb (7619 kg)
LGP (120 in blade, 27 in shoe)	17,550 lb (7959 kg)
Add-on weights --	
Drawbar	146 lb (66 kg)
Ripper (3 shank)	1,349 lb (612 kg)
Winch	1,000 lb (454 kg)
Front counterweight	752 lb (341 kg)
Cab	1,588 lb (720 kg)
ROPS heater	70 lb (32 kg)
CELT chain	115 lb (52 kg)
Center rockguard	154 lb (70 kg)
Sweeps	110 lb (50 kg)
Dual batteries	64 lb (29 kg)
90 in blade	917 lb (416 kg)
96 in blade	968 lb (439 kg)
112 in blade	1105 lb (501 kg)
120 in blade	1191 lb (540 kg)
CLT w/16 in closed shoe	2880 lb (1306 kg)
CELT w/16 in open shoe	2825 lb (1281 kg)
CLT w/20 in closed shoe	3259 lb (1478 kg)
CELT w/20 in open shoe	3204 lb (1453 kg)
CLT w/27 in closed shoe	3916 lb (1776 kg)
CELT w/27 in open shoe	3861 lb (1751 kg)

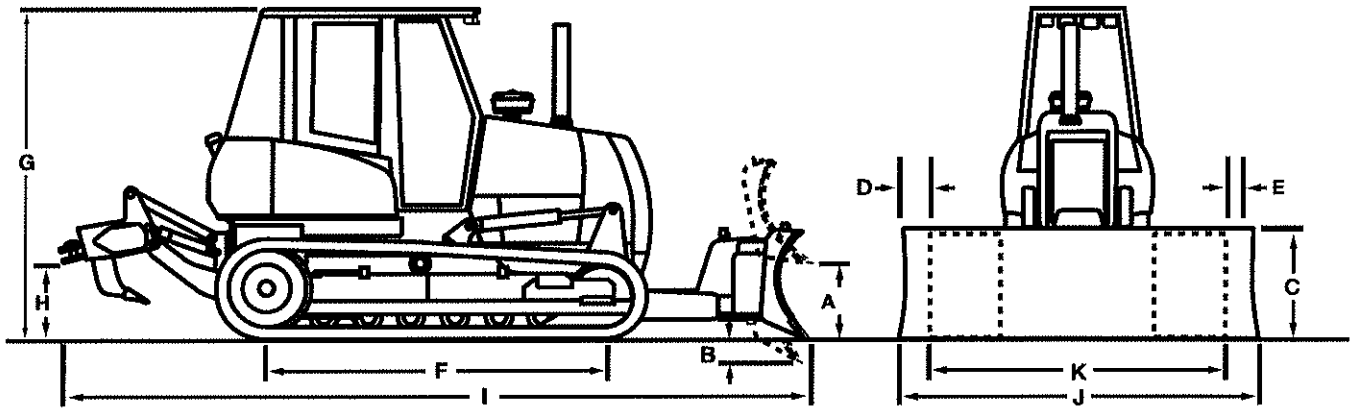

DIMENSIONS

	Long Track (LT)	Long Track (LT)	Wide Track (WT)	Low Ground Pressure (LGP)
BLADES				
Blade width	90 in (2286 mm)	96 in (2438 mm)	112 in (2845 mm)	120 in (3048 mm)
SAE blade capacity	1.58 yd ³ (1.21 m ³)	1.69 yd ³ (1.29 m ³)	2 yd ³ (1.53 m ³)	2.15 yd ³ (1.64 m ³)
A. Blade lift above ground	33.6 in (853 mm)	33.6 in (853 mm)	33.6 in (853 mm)	33.6 in (853 mm)
B. Blade depth below ground	20.09 in (531 mm)	20.9 in (531 mm)	20.9 in (531 mm)	20.9 in (531 mm)
Blade angle both directions	25°	25°	25°	25°
Blade tilt, each end (up to 9°)	14.2 in (361 mm)	15.2 in (386 mm)	17.8 in (452 mm)	19.0 in (482 mm)
C. Blade height	33.1 in (841 mm)	33.1 in (841 mm)	33.1 in (841 mm)	33.1 in (841 mm)
D. Cast reach	11.2 in (284 mm)	13.9 in (353 mm)	13.2 in (335 mm)	13.3 in (338 mm)
E. Cut reach	-1.6 in (-41 mm)	1.1 in (28 mm)	0.3 in (7 mm)	0.5 in (13 mm)
TRACKS				
Track gauge	56 in (1.42 m)	56 in (1.42 m)	68 in (1.73 m)	68 in (1.73 m)
Shoe width	16 in (406 mm)	16 in (406 mm)	20 in (508 mm)	27 in (686 mm)
F. Track on ground (CELT)	84 in (2.12 m)	84 in (2.12 m)	84 in (2.12 m)	84 in (2.12 m)
Area of track on ground	2630 in ² (1.70 m ²)	2630 in ² (1.70 m ²)	3372 in ² (2.18 m ²)	4552 in ² (2.94 m ²)
Ground pressure	6.2 psi (42.6 kPa)	6.2 psi (42.6 kPa)	5.0 psi (34.4 kPa)	3.9 psi (26.6 kPa)
DIMENSIONS				
G. Height to top of ROPS	104 in (2639 mm)	104 in (2639 mm)	104 in (2639 mm)	104 in (2639 mm)
Height to top of cab with air conditioning	104 in (2639 mm)	104 in (2639 mm)	104 in (2639 mm)	104 in (2639 mm)
H. Ground clearance at drawbar	14.4 in (366 mm)	14.4 in (366 mm)	14.4 in (366 mm)	14.4 in (366 mm)
I. Length –				
Blade straight with drawbar	163.3 in (4149 mm)	163.3 in (4149 mm)	163.3 in (4149 mm)	163.3 in (4149 mm)
Blade straight with ripper	195.8 in (4973 mm)	195.8 in (4973 mm)	195.8 in (4973 mm)	195.8 in (4973 mm)
J. Width –				
Blade straight	90 in (2286 mm)	96 in (2438 mm)	112 in (2845 mm)	120 in (3048 mm)
Blade angled	83.7 in (2126 mm)	89.2 in (2265 mm)	103.7 in (2634 mm)	110.9 in (2819 mm)
K. Over track	72 in (1828 mm)	72 in (1828 mm)	88 in (2235 mm)	95 in (2413 mm)

STANDARD EQUIPMENT

OPERATOR'S COMPARTMENT

Isolation mounted ROPS/FOPS canopy with headliner and floormat
Vinyl suspension seat w/back adjustment & adjustable armrests
Retractable seat belt, 2 in (51 mm)
Foot rests

ENGINE

Case 445TA/EGA diesel
Automatic fan belt tensioner
Integral engine oil cooling
Fuel filter
Dual element radial seal air cleaner
65 amp alternator
700 CCA 12-volt battery
Anti-sandblast radiator
Engine side panel
Anti-freeze to -34°F
Pusher fan

POWERTRAIN

Dual path infinitely variable, single-lever controlled hydrostatic drive with electronic straight tracking & counter-rotation, 4-position forward/reverse ratio control
Final drive -- Triple reduction -- helical gear/planetary
Decelerator with hydrostatic drive retardation
Automatic spring applied parking brake
10 incremental speed settings - Operator preference settings for max speed, shuttle sensitivity and steering sensitivity

BLADE

52° - 60° variable pitch
Single lever control for blade lift, angle and tilt

UNDERCARRIAGE

Case lubricated track chain
Easy clean track covers
Hydraulic track adjusters
Permanently lubricated track and carrier rollers
Track adjuster guard
Track guides (front and rear)

OTHER

Anti-vandalism package
Backup alarm
Decelerator
Final drive seal guard
Hand throttle
Horn
Lights -- halogen, 2 front, 1 rear for cab or ROPS
Master disconnect switch
Mirror
Operator's manual enclosure
O-ring face seal hydraulic fittings
Pre-cleaner
Vertical spin-on hydraulic/filters

OPTIONAL EQUIPMENT

OPERATOR'S COMPARTMENT

Cab (w/heater, 22,700 BTU (6.65 kW)/hr air conditioner, defroster, front windshield washer and 2F-1R lights)
3 in (76 mm) seat belt
Deluxe air suspension seat

HYDRAULICS

4 spool hydraulic valve for field-installed ripper

REAR MOUNTED EQUIPMENT

Ripper, parallelogram 5 slots with 3 shanks

BLADES

90 in (2.29 m)
96 in (2.44 m)
112 in (2.85 m)
120 in (3.05 m)

GUARDS

Sweeps
Center rockguard

SCREENS

Rear ROPS and cab
Side ROPS
Radiator brush

OTHER

Case extended life track
Cold start aid with dual 12-volt battery
Counterweight, front
Drawbar
Fan, reversible
Front pull hook
Lights -- halogen, 2 front, 1 rear for cab or ROPS
Retrieval hitch
Special paint
Sprocket, relieved (LT w/CLT only)
Turbo precleaner
Winch drive PTO

NOTE: All specifications are stated in accordance with SAE Standards or Recommended Practices, where applicable.

NOTE: All engines meet current EPA emissions requirements.

IMPORTANT: Case Construction Equipment Inc. reserves the right to change these specifications without notice and without incurring any obligation relating to such change. Case Construction Equipment Inc. does not warrant the safety or reliability of attachments from other manufacturers.

Case is a registered trademark of CNH America LLC. Any trademarks referred to herein, in association with goods and/or services of companies other than CNH America LLC, are the property of those respective companies.



www.casece.com





Warranty and Limitation of Liability North American Construction Equipment

The Case Warranty

The Case Warranty is a limited warranty that is provided to the initial retail purchaser in return for consideration paid as part of the purchase price of the product. The selling dealer must review the warranty coverage with the initial retail purchaser and obtain signature on the reverse side of this document.

New Limited Warranty

The warranty described here is from CNH America LLC and in Canada, CNH Canada Ltd., both of which are referred to in this brochure as "Case". This warranty is for Case products sold and registered in the United States or Canada and normally operated in the United States or Canada.

Warranty Period

For the products listed below, the Warranty Period for all coverage begins at the time that any person, dealer or agent first places the unit into service. At the latest, a unit is considered to be placed into service when purchased or delivered to an initial retail purchaser. Certain demonstrator, rental, lease, and other used units may be eligible for a portion of a new unit warranty. The availability of the remaining portion of a new unit warranty does not mean that a unit is new or unused. The Warranty Period ends when either the month or machine hour limit is reached, whichever limit occurs first.

PRODUCT	WARRANTY COVERAGE
SKIDSTEER / COMPACT TRACK LOADERS Case Engines	12 Months - Unlimited Hours 24 Months or 2000 Hours
CRAWLER DOZERS Case Engines Cummins Engine (1650K / 1850K)	12 Months - Unlimited Hours 24 Months or 2000 Hours 24 Months or 2000 Hours - Coverage and Terms Provided by Cummins Dealer
LOADER BACKHOES / FORKLIFTS Backhoe Main Boom, Standard Dipper Arm, Inner Dipper of the Extendahoe, and Swing Tower Castings. Case Engines, Torque Converter, Transmission, Drive Shafts, & Drive Axles	12 Months - Unlimited Hours 60 Months - Unlimited Hours 24 Months or 2000 Hours
WHEEL LOADERS Case Engines Cummins Engine In 921 Wheel Loader	12 Months - Unlimited Hours 24 Months or 2000 Hours 24 Months or 2000 Hours - Coverage and Terms Provided by Cummins Dealers
COMPACT WHEEL LOADERS Deutz Engines	12 Months - Unlimited Hours 24 Months or 2000 Hours - Coverage and Terms Provided by Deutz Dealer
ARTICULATED TRUCKS Case Engine Cummins Engine	12 Months - Unlimited Hours 24 Months or 2000 Hours 24 Months or 2000 Hours - Coverage and Terms Provided by Cummins Dealer
COMPACTION EQUIPMENT - SINGLE OR DOUBLE DRUM Cummins or Deutz Engines	12 Months - Unlimited Hours 24 Months or 2000 Hours - Coverage and Terms Provided by Cummins or Deutz Dealer
MOTOR GRADERS Cummins Engine	12 Months - Unlimited Hours 24 Months or 2000 Hours - Coverage and Terms Provided by Cummins Dealer
EXCAVATORS Case Engine Isuzu Engine	12 Months or 1800 Hours 24 Months or 2000 Hours 24 Months or 2000 Hours
COMPACT EXCAVATORS Yanmar Engines	12 Months or 1000 Hours 12 Months or 1000 Hours
Warranty does not cover any configuration excavator equipped with feller buncher/accumulator attachments	

What's Covered

If a defect in material or workmanship is found in a unit and reported during the Warranty Period, Case will pay parts and labor costs to repair the defect if the services are performed by an authorized Case or Case dealer at the dealer's location. If parts are needed during the repair, Case will, at its option, use genuine Case or remanufactured parts. Case replacement parts that are used in a repair are covered by the Case Replacement Parts Warranty.

CASE PROVIDES NO WARRANTY, EXPRESS OR IMPLIED, FOR A COMPONENT OR OTHER ITEM THAT IS SEPARATELY WARRANTED TO THE PURCHASER BY ITS MANUFACTURER, SUCH AS TIRES, BATTERIES AND FUEL INJECTION COMPONENTS. CHECK WITH YOUR DEALER FOR DETAILS.

EXCLUSIVE REMEDY
THE REMEDY OF REPAIRING A DEFECT IN MATERIALS OR WORKMANSHIP AT A CASE DEALERSHIP UNDER THE TERMS OF THIS WARRANTY IS THE PURCHASER'S EXCLUSIVE REMEDY AND IS IN LIEU OF ANY OTHER REMEDY OTHERWISE AVAILABLE.

Continued on reverse side

No Modification or Extension of Warranty

The Case Warranty is limited to the written terms in this pamphlet. Case does not authorize any person, dealer or agent to change or extend the terms of this warranty in any manner. Any assistance to the purchaser in the repair or operation of any Case product outside the terms or limitations or exclusions of this warranty will not constitute a waiver of the terms, limitations or exclusions of this warranty, nor will such assistance extend or re-establish the warranty.

This Warranty Is Void If:

The unit's hour meter is changed or altered, unless a Case dealer, at the direction of Case, changed the meter. If the unit is used in an application for which it is not designed or the unit has been scrapped, salvaged, stolen, junked or totaled.

Limitations and Exclusions

The Case Warranty gives you specific legal rights and you may also have other rights, which vary, from state to state.

THIS DOCUMENT CONTAINS THE ENTIRE CASE WARRANTY. CASE MAKES NO OTHER REPRESENTATIONS OR WARRANTIES, EXPRESSED OR IMPLIED, AND SPECIFICALLY EXCLUDES THE IMPLIED WARRANTIES OF MERCHANTABILITY AND FITNESS FOR PARTICULAR PURPOSE. CASE WILL NOT BE LIABLE FOR INCIDENTAL OR CONSEQUENTIAL DAMAGES RESULTING FROM A BREACH OF THE WRITTEN WARRANTY OR ANY IMPLIED WARRANTY IMPOSED BY LAW.

* These limitations and exclusions may not be allowed by some states or provinces, and they shall not apply to the extent such limitations or exclusions are not allowed by applicable state/provincial law.

Owner's Responsibility

The Case Warranty remains in effect during the Warranty Period if the owner performs the required maintenance at the recommended intervals outlined in the product's operator's manual and the unit is operated within its rated capacity. Genuine Case service parts or Case approved service parts that meet Case specifications must be used for maintenance and repairs.

What's Not Covered

- Replacement of non-defective wear items expected to be replaced during the warranty period, including, but not limited to: lights, fuses and belts, bucket cutting edges and teeth, crawler track pads and track components, crop processing and cutting components, drive sprockets and chains, soil engaging tools and accessories or items replaced due to customer demand.
- Normal maintenance parts and service, including, but not limited to lubrication, coolants and filters.
Note: Lubricants, filters, and coolants do not qualify for warranty reimbursement unless they require replacement as a DIRECT RESULT of a defect in material or workmanship.
- Any and all costs for coolant, fuel, or tube (oil) analysis including supplies and lab recommendations.
- New Case products, parts and components that are covered by separate and specific warranties including but not limited to: tires, batteries, fuel injection pumps and Advanced Farming Systems.
- Any and all travel costs associated with hauling or towing a customer's machine to and from a customer's machine related to any warranty repair unless specifically covered by a program or policy.
- Repairs arising from any unauthorized modification to the product or the use of non-Case attachments.
- Repairs arising from service performed by agents not approved by Case.
- Repairs arising from storage deterioration, failure to maintain the equipment, improper use of the equipment, collision or other accident, vandalism, or other casualty, or operation beyond rated capacity or specifications.
- Repairs arising from abuse or neglect including, but not limited to: operation without adequate coolant or lubricants, adjustments to the fuel system outside the equipment specifications, overspeeding, improper storage, starting, warm-up, or shutdown practices, incorrect fuel or contaminated fuel, oil or other fluids.
- Failure of the machine, its implements or attachments caused by improper field application or overloading.
- Premiums charged for overtime labor costs.
- Economic loss, including lost profits, crop loss, equipment rental or other expense.
- Cost associated with cleaning of machine in preparation for servicing.
- Loss or damage during shipment.
- Cost of initial setup or installation of any optional equipment or attachments to a unit.
- Items used for repairs including, but not limited to are: solvents, cleaners, anti-seize lubricants, oil-dry, shop towels, special tools, etc.
- Included, but not limited to are: checks, adjustments, and shimming, engine tune-ups, fuses.
- Unauthorized modification or field fixes, (i.e., updating machines based on Service Bulletin information).
- Any and all cost of special tools or shop supplies incurred with repairs.
- Claims for stolen equipment.
- Claims for replacing a complete assembly when the repair is less than the replacement.
- Claims involving the inspection or reconditioning of units.
- Shop comebacks: any duplicate, repeat, or comeback repair resulting from improper diagnosis, testing, or poor service work.
- Cost of removing or installing Non-Case Brand optional equipment or attachments including but not limited to loaders, duals, tanks, etc.

Additional Purchased Protection

Many units qualify for the Case Flexible Purchased Protection Plan. This plan gives the owner additional coverage on select engine and drive train components. Discuss the details with your Case dealer today.

Operator's Manual / Warranty Receipt Verification

The correct operator's manual has been reviewed with me by the selling dealer and will be given to me upon delivery of the product.

YES/NO

The correct operator's manual has been given to me. YES / NO

The selling dealer explained safety precautions to me. YES / NO

The selling dealer explained safety features of the product to me. YES / NO

The selling dealer explained the warranty terms and coverage to me. YES / NO

The answers circled above are correct. I acknowledge that I have read and I accept this warranty policy statement

Model -	Product identification number
Operator's manual form number -	
Customer name (Please Print) -	
Purchaser	
Address	Dealer Name
City, State, Zip	City, State, Zip

Purchaser
Signature _____ Date _____

Dealer
Signature _____ Date _____

Mail original signed copy to 360 Services Inc. 12623 Newburgh Road, Livonia, MI 48150, USA.

L SERIES CRAWLER DOZERS

650L LT | 650L WT | 650L LGP

When the job calls for heavy earthmoving, site prep, steep slope work or rough and finish grading, you need a crawler dozer with superior push power, control and maneuverability. Plus, if you're on the job site from sunup to sundown, you also need a cab that keeps your operator comfortable all day. The Case 650L crawler dozer is powerful, easy to operate, durable, comfortable and long on uptime — just what you need to be more productive.

More push power

This machine has the muscle and finesse to get the job done quickly. The new Tier 3-certified engine produces 74 net horsepower. The hydrostatic PowerStat drivetrain delivers outstanding power to each track through sturdy drive motors. More material is pushed through the turn, reducing the number of passes required.

Easy, precise operation

The easy-to-use, single-lever travel control allows for efficient, precise operation and the low-effort blade control provides simultaneous multifunction control. You can maintain power to both tracks while turning, allowing you to push a full load through a turn without losing control of the load or raising the blade.

Superior comfort and visibility

To get the most out of every day, the isolation-mounted operator's station has been designed with more comfort, productivity and safety in mind. The operator's compartment provides the clearest view to the blade and the entire job site. For maximum operator comfort, the optional cab includes heat, defroster, air conditioning, front windshield washer and an air suspension seat.

Built-in serviceability increases uptime

Case leads the industry in serviceability. Eye-level fluid sight gauges and ground-line service checks provide simple daily maintenance. The easy-tilt operator's seat offers convenient access to powertrain components and optional diagnostic test ports make the Case dozers as easy to care for as they are to operate. These advantages boost uptime and lower ownership costs.



650L LT

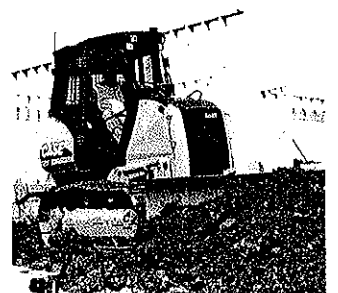

L SERIES CRAWLER DOZERS

650L LT | 650L WT | 650L LGP

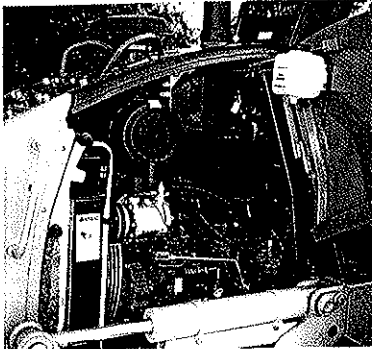

Tier 3-certified engine

The 650L crawler dozer is powered by a 4.5-liter turbocharged Case Tier 3-certified engine, which delivers 74 net horsepower and provides clean burning power and plenty of torque to move more material per hour. Charge air cooling and high pressure, common rail injection lines with electronic injectors offer smooth power and excellent fuel efficiency.

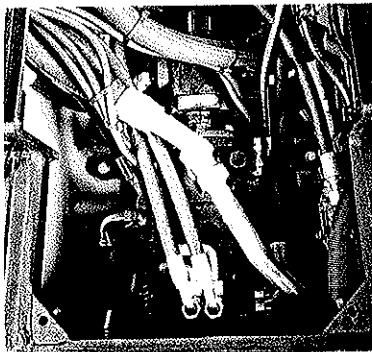

Hydrostatic drive delivers maximum power

The Case PowerStat system has a dual path hydrostatic drive that delivers superior power to each track through large drive components. Hydrostatic pumps are isolation-mounted to the frame for quiet, smooth and more comfortable operation.

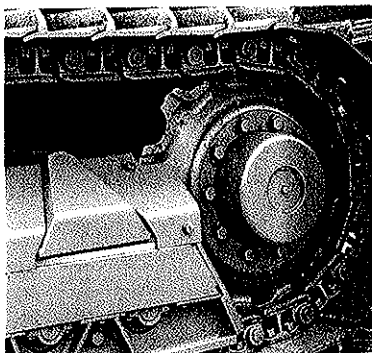

Undercarriage options

Case Lubricated Track is sealed and lubricated with an oil reservoir in each pin. Case Extended Life Track, shown here, uses a large diameter, hardened bushing that is free to rotate on the standard bushing, providing outstanding durability and life in abrasive conditions.

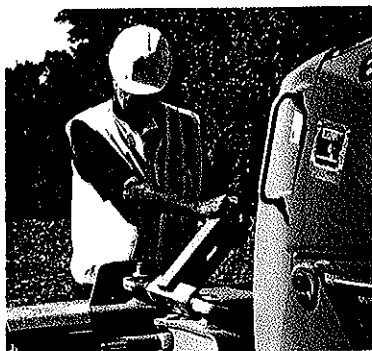

Adjustable blade pitch

Blade pitch is easily adjusted with a built-in tool from a maximum 52 to 60 degrees to best match soil conditions.

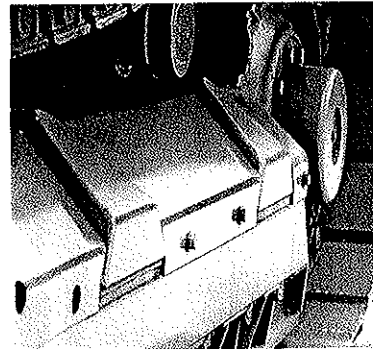

Sloping track frame covers

The 49-degree sloping track frame cover and ample space between the track and machine make it easy to keep the undercarriage free of dirt, rocks and debris.





Quieter, more comfortable cab

The optional isolation-mounted cab makes the 650L one of the quietest working spaces in the industry. A fully adjustable cab environment enables you to match any operator preference.



Low operating height

The height to the top of the ROPS is 104 inches, making this machine ideal for residential construction projects. The low overall operating height allows for easy transport.



High visibility

The narrow Advanced Instrumentation Cluster and tapered hood provide wide open visibility to the blade to gauge material flow.

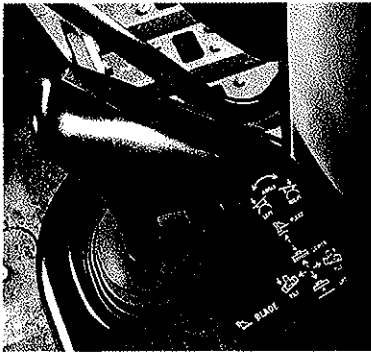

Single-lever blade control

The low-effort single-lever control for the six-way blade simplifies operation and gives the operator complete control of the blade.

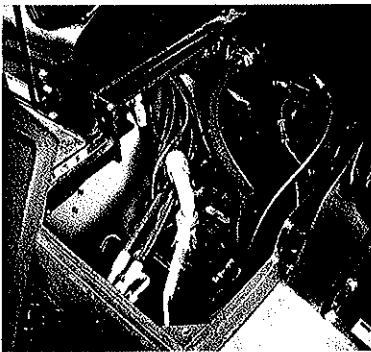

More uptime and productivity

Keeping your Case crawler dozer in top running shape requires less effort, thanks to the ground-line access to the engine and all daily maintenance checkpoints. Even hydrostatic components are quickly accessible through the easy-tilt operator's seat.

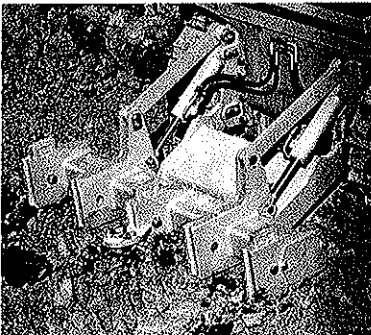

A variety of attachments

Optional attachments are available to increase your productivity. Do more with one machine by adding a winch, ripper, retrieval hitch or drawbar.

L SERIES CRAWLER DOZERS

650L LT | 650L WT | 650L LGP

More push power

Case designed the dual path hydrostatic drive to deliver the muscle to push the fullest blades through turns – and reduce the number of passes required to move material. You'll feel the powerful, turbocharged Tier 3-certified engine (74 net horsepower) as soon as you get behind the controls. Plus, the multiple speed settings and infinitely variable steering provide maximum maneuverability with counter rotation.

Easy, precise operation

When it comes to operating a rugged earthmoving machine, it doesn't get much easier – or more precise – than Case crawler dozers. The single-lever control for the six-way blade simplifies operation. You can also adjust the sensitivity of the steering and forward/reverse modulation to match personal preferences or applications.

The easy-to-operate controls boost productivity, and the advanced hydraulics and steering combine for a smooth operation whether the job involves heavy dozing or finish grading.

Superior comfort and visibility

The isolation-mounted cab on the 650L cushions against noise and vibration to keep you comfortable and productive all day long. For added comfort, heat, air conditioning and an air suspension seat are available.

Panoramic tinted glass gives you maximum forward, side and rear visibility. The narrow, modular dashboard provides a clear, direct line of sight to the cutting edge, making it easy to gauge the flow of material under the blade.

Built-in serviceability increases uptime

Case crawler dozers are as easy to service as they are to operate. Swing-out service panels for easy access and ground-line sight gauges for hydraulic fluid levels help speed up daily maintenance. Optional hydraulic test ports provide fast and easy troubleshooting. The easy-tilt operator's seat provides convenient access to hydrostatic components within minutes.

For easy undercarriage cleaning, the 650L is equipped with a 49-degree sloping track frame cover and ample space between the track and machine to help keep the undercarriage free of dirt, rocks and debris.

Case crawler dozers are engineered for easy daily maintenance and routine service – which increase your uptime and profits.

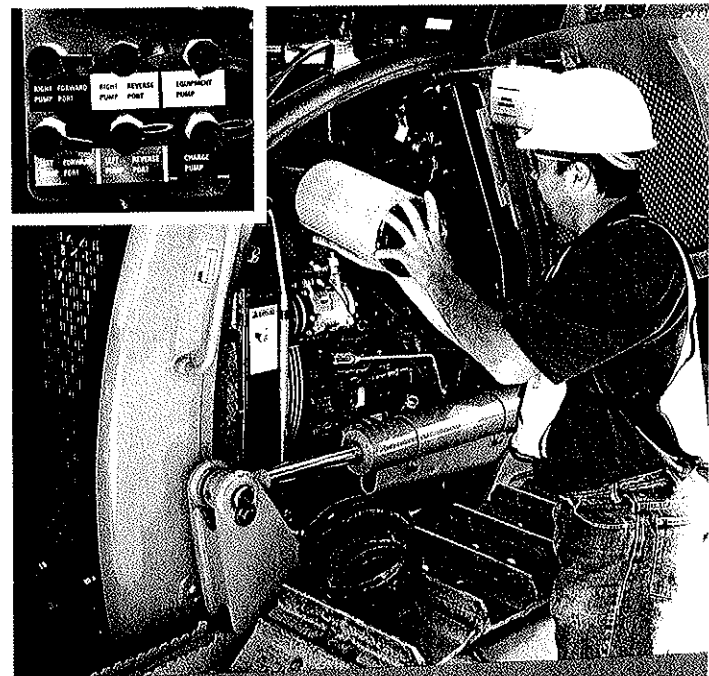
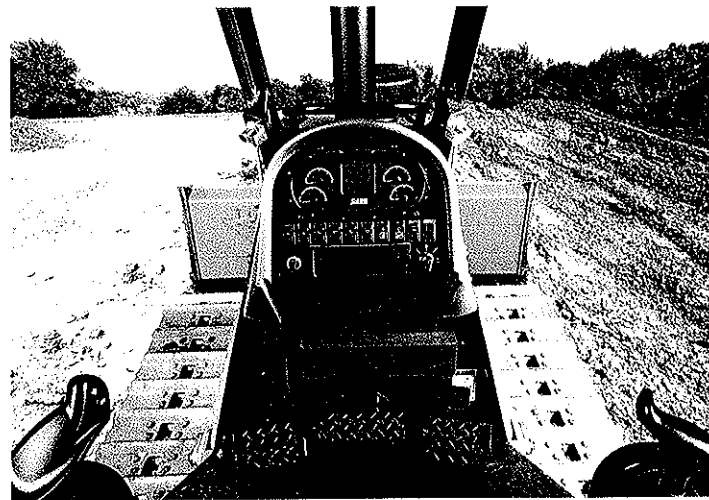

You can count on Case

You can count on Case and your Case dealer for full-service solutions—productive equipment, expert advice, flexible financing, genuine Case parts and fast service. We're here to provide you with the ultimate ownership experience.

Case pride

You can take pride in the Case name on your machine. It's backed by more than a century of productivity and performance. Case and your Case dealer are here for you, not only when you buy the machine, but also after you put 1,000 or 10,000 hours on it.

A rich, proud history

Case Construction Equipment's heritage spans more than 165 years. Growing from J.I. Case's innovations with steam-powered machinery in the late 1800s, Case developed road-building equipment that helped create early 20th century streets and highways across the world. By 1912, Case was well on its way to establishing itself as a full-line equipment manufacturer. The company continued to expand its construction equipment business over the years.

Celebrating a tradition of innovation

In 1957, Case produced the world's first integrated loader/backhoe made and warranted by one manufacturer. Over the decades and into the 21st century, Case has continued to develop a long line of industry firsts and has taken a leadership role in pioneering new products and solutions. Today, Case produces 15 lines of equipment and more than 90 models to meet your toughest construction challenges. Supported by manufacturing and sales in more than 150 countries, Case serves the needs of our customers worldwide.

Coast-to-coast customer support

In North America, Case equipment is sold and serviced by more than 375 dealer locations. No matter where you work, we're here to support and protect your investment and exceed your expectations.

To locate a Case dealer or learn more about Case equipment or customer service, go to www.casece.com or call 1-866-54CASE6.

It all adds up. You can count on Case.

Case Delivers Full-Service Solutions

EQUIPMENT | FINANCING | PARTS & SERVICE

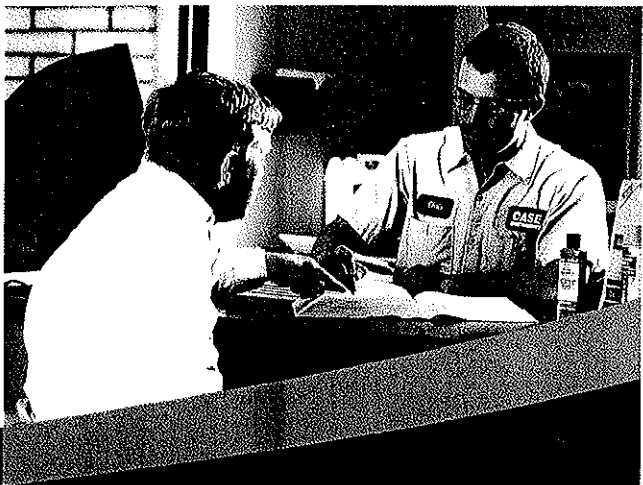

L SERIES CRAWLER DOZERS

650L	LT Long Track	WT Wide Track	LGP Low Ground Pressure
Engine	74 net hp (55 kW)	74 net hp (55 kW)	74 net hp (55 kW)
Operating weight	16,250 lb (7371 kg)	16,800 lb (7619 kg)	17,550 lb (7959 kg)
Blade capacity	1.7 cu yd (1.3 cu m)	2.0 cu yd (1.5 cu m)	2.2 cu yd (1.6 cu m)
Case Extended Life Track on ground	84 in (2.1 m)	84 in (2.1 m)	84 in (2.1 m)
Biodiesel	B20	B20	B20

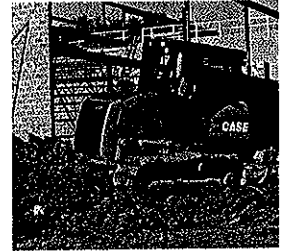

650L LT

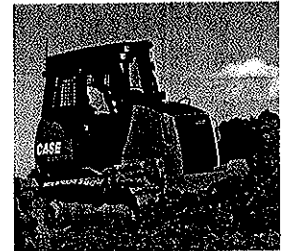

650L WT



650L LGP

NOTE: All engines meet current EPA emission regulations.

NOTE: All specifications are stated in accordance with SAE standards or recommended practices, where applicable.

IMPORTANT: Case Construction Equipment Inc. reserves the right to change these specifications without notice and without incurring any obligation relating to such change. Availability of some models and equipment builds vary according to the country in which the equipment is used. The illustrations and text may include optional equipment and accessories and may not include all standard equipment. Your Case dealer/distributor will be able to give you details of the products and their specifications available in your area.



Always read the operator's manual before operating any equipment. Inspect equipment before using it, and be sure it is operating properly. Follow the product safety signs and use any safety features provided.

©2009 CNH America LLC. All rights reserved. Case is a registered trademark of CNH America LLC. Any trademarks referred to herein, in association with goods and/or services of companies other than CNH America LLC, are the property of those respective companies. Printed in U.S.A.

Form No. CCE200904650L

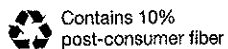

Case construction equipment is biodiesel friendly.

State Equipment Inc
560 New Goff Mountain Road
Cross Lanes, WV 25313
304-776-4405



Looking for product specs, customer testimonials, competitive comparisons, finance offers and more?
Visit us at www.casece.com or call 866-54CASE6



Flexible Purchased Protection Limitation of Liability North American Construction Equipment

The Case Flexible Purchased Protection Warranty

The Case Flexible Purchased Protection (FPP) is a limited warranty that is provided to the initial retail purchaser in return for additional monies paid. The selling dealer must review the FPP coverage with the initial retail purchaser and obtain signature on the reverse side of this document.

FPP Limited Warranty

The warranty described here is from CNH America LLC and in Canada, CNH Canada Ltd., both of which are referred to in this brochure as "Case". This warranty is for Case products sold and registered in the United States or Canada and normally operated in the United States or Canada.

FPP Period

The duration of the FPP period warranty will depend on the coverage purchased. If the plan lists a month or year limit and a machine hour limit, the plan expires when the first of those limits are reached. FPP limits are measured from the date the equipment was first placed into service by the dealer or customer.

What's Covered

If a defect in material or workmanship is found in a unit and reported during the FPP period, Case will pay parts and labor costs to repair the defect if the services are performed by an authorized Case dealer at the dealer's location. If parts are needed during the repair, Case will, at its option, use genuine Case or remanufactured parts. Case replacement parts that are used in a repair are covered by the Case Replacement Parts Warranty.

Case provides no warranty, expressed or implied, for a component or other item that is separately warranted to the purchaser by its manufacturer, such as tires, batteries and fuel injection components. Check with your dealer for details.

**EXCLUSIVE REMEDY
THE REMEDY OF REPAIRING A DEFECT IN MATERIALS OR
WORKMANSHIP AT A CASE DEALERSHIP UNDER THE TERMS
OF THIS WARRANTY IS THE PURCHASER'S EXCLUSIVE
REMEDY AND IS IN LIEU OF ANY OTHER REMEDY
OTHERWISE AVAILABLE.**

No Modification or Extension of Warranty

The Case Warranty is limited to the written terms in this pamphlet. Case does not authorize any person, dealer or agent to change or extend the terms of this warranty in any manner. Any assistance to the purchaser in the repair or operation of any Case product outside the terms or limitations or exclusions of this warranty will not constitute a waiver of the terms, limitations or exclusions of this warranty, nor will such assistance extend or re-establish the warranty.

This Warranty is Void if

The unit's hour meter is changed or altered, unless a Case dealer, at the direction of Case, changed the meter. If the unit is used in an application for which it is not designed or the unit has been scrapped, salvaged, stolen, junked or totaled.

Owner's Responsibility

The Case FPP Warranty remains in effect during the selected period if the owner performs the required maintenance at the recommended intervals outlined in the product's operator's manual and the unit is operated within its rated capacity. Genuine Case service parts or Case approved service parts that meet Case specifications must be used for maintenance and repairs.

Limitations and Exclusions

FPP Warranty gives you specific legal rights and you may also have other rights, which vary, from state to state.

*These limitations and exclusions may not be allowed by some states or provinces, and they shall not apply to the extent such limitations or exclusions are not allowed by applicable state/provincial law.

Systemgard® Oil Analysis

The Case Systemgard® Oil Analysis service is available and is provided to the customer at no charge. Case highly recommends that customers use Systemgard™ service for equipment covered by this plan. Should a repair be necessary during the coverage period, Case may require that the customer provide lube analysis information to demonstrate that the proper maintenance has been performed within the guidelines of the operator's manual and Case warranty policies.

FPP Deductible Option

- The equipment owner shall pay the first \$250 (\$380 in Canada) of repair costs for all equipment covered under this warranty where the deductible options was elected.
- This deductible will be applied to each incident of failure.
- This deductible will be waived identical repairs to the same part previously repaired under the FPP if the same person owns the equipment.
- Any transportation, travel, or other expense not covered by this warranty shall not apply toward payment of this deductible.

Additional Terms

- The original or subsequent purchaser of new or used equipment may add FPP anytime during the machine's base warranty period.
- Once FPP options have been selected, the coverage can be upgraded only during base warranty.
- The coverage for "severe duty" application is limited. "Severe duty" applications include equipment used in forestry, demolition, scrap & waste recycling, mining foundry chemical, landfills and other applications determined to be significantly detrimental to equipment and component life. If a dealer or customer misrepresents the application in which the product will be used, the base warranty and the FPP coverage will be terminated.
- The plan coverage shall be effective only upon receipt of a valid Warranty Registration by Case for the FPP within the established limitations of the plan.
- Coverage can be transferred, without charge, to subsequent owners. A new Warranty Registration must be submitted by a Case dealer that is authorized to sell and service the unit to validate the coverage transfer. FPP coverage will be void if a unit is transferred from a normal duty application to a "severe duty" application.

Machine Coverage

Machine Coverage includes the Power Train and Hydraulic Coverage which is described below plus coverage for the following major component systems: fuel, electrical, undercarriage, and chassis (see "what's not covered").

Power Train and Hydraulic Coverage

Power Train and Hydraulic Coverage includes Power Train Only coverage, which is described below, plus coverage for the following major component systems: hydraulic components that enable the steering and hydraulic functions including pumps, motors, hydraulic valves and hoses, and hydraulic cylinders.

Power Train Coverage

The Power Train Coverage provides protection for the following engine and driveline component. Any component not listed below is not covered under the Power Train Coverage.

Note: This plan does not provide coverage for the Cummins, Kubota, or Deutz engines in Case machine.

Continued on Reverse Side

Engine Coverage Includes: All internal, lubricated parts that are captured between the valve cover and oil pan, cylinder block and head, front cover and flywheel housing, turbocharger, and water pump.

Note: All engines are eligible for this coverage except Cummins, Kubota, or Deutz engines.

Drive Line Coverage Includes: Drive (flex) plates / flywheel, drive axle assembly, drive couplings, drive shafts / universal joints, final drive / planetary, hydraulic drive pump and motors, when used as a power source for machine propulsion drive components, propulsion planetary drive, pump drive coupling, pump drive gearbox, swing reducer transmission, torque converter, track steering brakes and clutch, transfer gear group, transmission charge pump, transmission / transmission control valve, trencher drive gearbox, turntable bearing / swing gear / hydraulic swivel, and wet brakes / wet clutch.

COMPONENTS NOT LISTED UNDER POWER TRAIN COVERAGE ARE NOT WARRANTED

What's Not Covered

- Replacement of non-defective wear items expected to be replaced during the warranty period, including, but not limited to: blade, buckets, bucket teeth, bulbs, cutting edges, drive belts/chains/sprockets, ground engaging parts, lubricated joints such as pins and bushings. Undercarriage and other components that are covered by certain FPP plans are not warranted against breaking or complaints related to wear or wear of related parts. FPP does not cover wear items perceived as "abnormally worn" or items replaced due to customer demand.
 - Normal maintenance parts and service, including, but not limited to lubrication, coolants, filters and thermostats.
- Note: Lubricants, filters, and coolants do not qualify for warranty reimbursement unless they require replacement as a DIRECT RESULT of a defect in material or workmanship.**
- Any and all costs for coolant, fuel, or lube (oil) analysis including supplies and lab recommendations.
 - New Case products, parts and components that are covered by separate and specific warranties including but not limited to: tires, batteries, and fuel injection pumps.
 - Travel costs associated with hauling or towing a customer's machine to and from a customer's location related to any warranty repair unless specifically covered by a program or policy.
 - Repairs arising from any unauthorized modification to the product or the use of non-Case attachments.

- Repairs arising from service performed by agents not approved by Case.
- Repairs arising from storage deterioration, failure to maintain the equipment, improper use of the equipment, collision or other accident, vandalism, or other casualty, or operation beyond rated capacity or specifications.
- Repairs arising from abuse or neglect including, but not limited to: operation without adequate coolant or lubricants, adjustments to the fuel system outside the equipment specifications, overspeeding, improper storage, starting, warm-up, or shutdown practices, incorrect fuel or contaminated fuel, oil or other fluids.
- Failure of the machine, its implements or attachments caused by improper field application or overloading.
- Premiums charged for overtime labor costs.
- Economic loss, including lost profits, crop loss, equipment rental or other expense.
- Cost associated with cleaning of machine in preparation for servicing.
- Cost of Initial setup or installation of any optional equipment or attachments to a unit.
- Items used for repairs include, but not limited to are: solvents, cleaners, anti-seize lubricants, oil-dry, shop towels, special tools, etc.
- Included, but not limited to are: checks, adjustments, and shimming, engine tune-ups, fuses.
- Unauthorized modification or "field fixes," i.e., updating machines based on Service Bulletin information.
- Claims for replacing a complete assembly when the repair cost is less than the replacement.
- Claims involving the inspection or reconditioning of units.
- Shop comebacks: any duplicate, repeat, or comeback repair resulting from improper diagnosis, testing, or poor service work.
- Cost of removing or installing Non-Case Brand optional equipment or attachments including but not limited to loaders, duals, tanks, etc.
- **Customer comfort items** such as but not limited to: air and water leaks caused by aged weather stripping, carpets and floor mats, faded paint or rust, glass, hinges, interior cab moldings and panels, knobs for switches and handles, noise, rattles, seat cushions, and squeaks.

CASE PROVIDES NO WARRANTY, EXPRESS OR IMPLIED, FOR A COMPONENT OR OTHER ITEM THAT IS SEPARATELY WARRANTED TO THE PURCHASER BY ITS MANUFACTURER.

OPERATOR'S MANUAL/WARRANTY RECEIPT VERIFICATION

The selling dealer explained safety features of the product to me. **YES / NO**

The selling dealer explained the warranty terms and coverage to me. **YES / NO**

The answers circled above are correct. I acknowledge that I have read and I accept this warranty policy statement.

The Flexible Purchase Protection terms are: FPP Expiration Date _____ FPP Expiration Hours _____ Deductible Amount _____

Model -	Product identification number
Customer name (Please Print)	
Purchaser	Dealer Name
Address	City, State, Zip
City, State, Zip	

Purchaser Signature _____ Date _____

Dealer Signature _____ Date _____

Mail original signed copy to 360 Services Inc. 12623 Newburgh Road, Livonia, MI 48150, USA

Master Parts Schedule- New Construction Equipment

(see exclusions in PPP Policy Document)

Powertrain Only	Powertrain Plus Electronics	Powertrain Plus Hydraulics	Premier
<p>The Powertrain Only coverage provides for the following engine and driveline Components. Any Component not listed below is not covered under the Powertrain Only Coverage.</p> <p><u>Engine</u> All internal, lubricated parts that are captured between the valve cover and oil pan, cylinder block and head, front cover and flywheel housing, turbocharger and water pump.</p> <p><u>Drive Line</u> Drive (flex) plates/flywheel Drive axle assembly Drive couplings Drive shafts Final drive/planetary Hydraulic Drive Motor (on Hydrostatically Driven units only, including Excavators) Hydraulic Drive Pump (on Hydrostatically driven units Only, including Excavators) Hydraulic Pump (when used as a Swing Reducer) Transmission Torque converter Track Steering Brakes Transfer Gear Group Transmission Charge Pump Transmission/Transmission Control Valve Turntable Bearing/ Swing Gear/ Hydraulic Swivel Electronic Engine Controls Injection Pumps Wet Brakes/Wet clutch MFWD Assemblies Sealed Universal Joints CV Joints</p> <p><u>Compaction Equipment</u> Propulsion System Hydraulic Components Torque Hubs Pump Drive Splitter Box Reduction Unit Vibration System Hydraulic Components Eccentric Mechanism & Bearings</p>	<p>Powertrain Plus Electronics includes Powertrain Only Components along with the following Major Components systems:</p> <p><u>Drive Train Electronic Controls</u> Traction Control System Electronic Control Module Wheel Speed Sensor Brake Proportional Solenoid Valve On / Off Pilot Solenoid Valve Articulation Angle Position Sensor Brake Pressure Reducing Valve Drive Train Electronic Control Module Brake Position Sensor</p> <p><u>Implement Electronic Controls</u> Implement Electronic Control Module Frame Level Control Linkage Position Sensor Control Lever Position Sensor</p> <p><u>Exclusions:</u> Wiring Harnesses, Instruments Gauges Resistors Indicators Light Bulbs Circuit Breakers Fuses Switches Motors Electric Joysticks Batteries</p>	<p>Powertrain Plus Hydraulics includes the Powertrain Only components along with the following Major Component systems:</p> <p><u>Hydraulics</u> Main Hydraulic Pump Steering pump Main control valves Hydraulic lift cylinders Hydraulic lift/dump cylinders Hydraulic steering cylinders Hydraulic boom cylinders Hydraulic stick cylinders Hydraulic bucket cylinders</p> <p>Hoses, excluding external packing, seals, o-rings and bonded washers, quick connects.</p> <p>O-ring failures in hoses, not related to loose fittings or worn out seals, are covered.</p>	<p>Premier includes the Powertrain Only, Powertrain Plus Electronics, and Powertrain Plus Hydraulics, along with the following Major Component systems:</p> <p><u>Fuel system</u> Fuel Transfer/ lift pumps, Injection pumps and lines that do not fall into the Emissions Warranty guidelines.</p> <p><u>Electrical</u> Wiring harnesses Sensors Instruments Gauges Indicators Circuit Breakers Relays Switches Motors Joysticks</p> <p><u>Hydraulics</u> Steering Hydraulic Components</p> <p><u>Chassis/ Frame/Cab</u> Weldment failures A/C system (excludes Dryer Failures) Exhaust system: includes manifolds and muffler Internal door latch mechanisms/ Weldment failures Cooling System: Radiator and cooler failures not related to corrosion, decay, or deterioration</p> <p><u>Exclusions:</u> Comfort Items listed in policy document</p>

***Note: Emissions and Parts Warranty related failures should be filed back to the manufacturer, and NOT through PPP; in accordance with the manufacturer's operating guidelines and conditions**

****Note: Field Campaigns/factory directed repairs should NOT be filed through the PPP. Please direct to the Manufacturer.**

Revised 06.01.2010

This literature is descriptive only. The precise protection afforded is subject to the terms, conditions and exclusions of the contract as issued. Program participation is subject to customer credit qualification and/or other underwriting requirements. Programs may be changed or cancelled without notice. Capitalized terms used in this literature, unless defined herein, have the meanings assigned to them in the contract as issued.

H4A Hydraulic Winch



Performance

Winch Model (Type) Winch Gear Ratio Winch Drive Motor Speed			H4AH (Hi-P) 94:1		H4AH (Hi-P) 116:1		H4AT (Rescue) 116:1*		H4AT (Rescue) 125:1*	
Layer	Situation	Units	HI	LO	HI	LO	HI	LO	HI	LO
Bare Drum	Max. Pull	Lbs.	18,150	38,600	22,350	47,500	17,000	39,700	3,300	32,150
		(Kg)	(8,233)	(17,509)	(10,138)	(21,546)	(7,711)	(18,008)	(1,497)	(14,583)
	Max. Speed	fpm	105	63	85	51	48	28	46	28
		(mpm)	(32.0)	(19.2)	(25.9)	(15.5)	(14.6)	(8.5)	(14.0)	(8.5)
Full Drum	Max. Pull	Lbs.	10,350	22,050	12,750	27,150	9,700	22,700	1,850	18,350
		(Kg)	(4,695)	(10,002)	(5,783)	(12,315)	(4,400)	(10,297)	(839)	(8,323)
	Max. Speed	fpm	184	110	149	89	84	50	81	48
		(mpm)	(56.1)	(33.5)	(45.4)	(27.1)	(25.6)	(15.2)	(24.7)	(14.6)

* Ratio 116:1 used on tractors with more than 3,300 psi, ratio 124:1 on tractors with less than 3,300 psi.

Dimensional Data

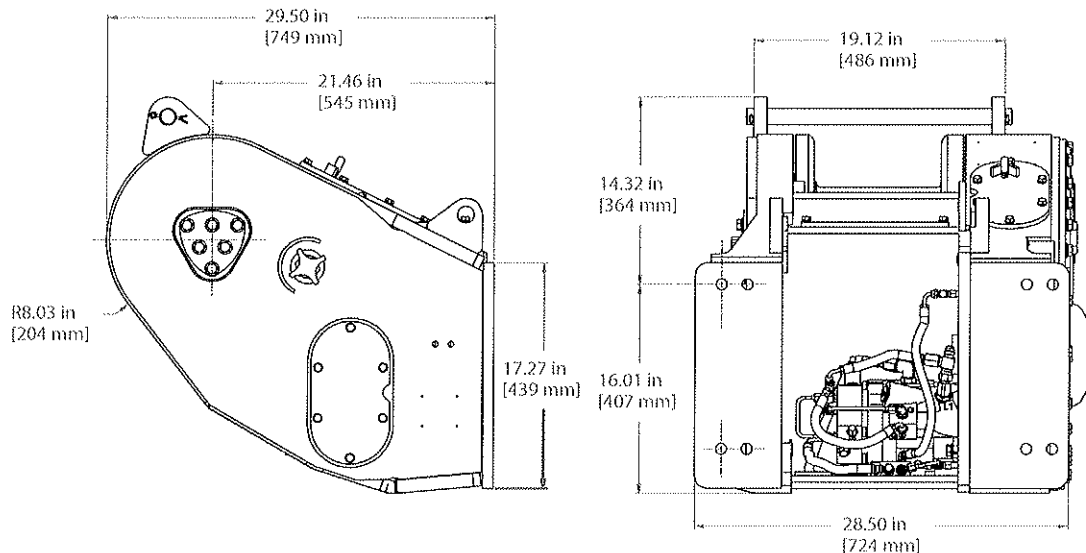

Specifications

Drum Size

Barrel Diameter8.00 in. (203mm)
 Barrel Length.....9.50 in. (241mm)
 Flange Diameter 16.00 in. (406mm)

Drum Capacity

5/8-inch (16mm) cable 277 ft. (84.4m)
 3/4-inch (19mm) cable 195 ft. (59.4m)

Weight

1,350 lbs. (612 kg), including pump, hoses, filter and control.

Ferrule Size

Type	Length	Diameter
B5	2 in. (51mm)	1.5 in. (38mm)
B6	2 in. (51mm)	1.5 in. (38mm)



21433 SW Oregon Street
 Sherwood, OR 97140 USA
 phone: 503.625.2560
 fax: 503.625.7269
 www.alliedsystems.com
 marketing@alliedsystems.com

DISTRIBUTED BY:

H4A Hydraulic Winch



Description

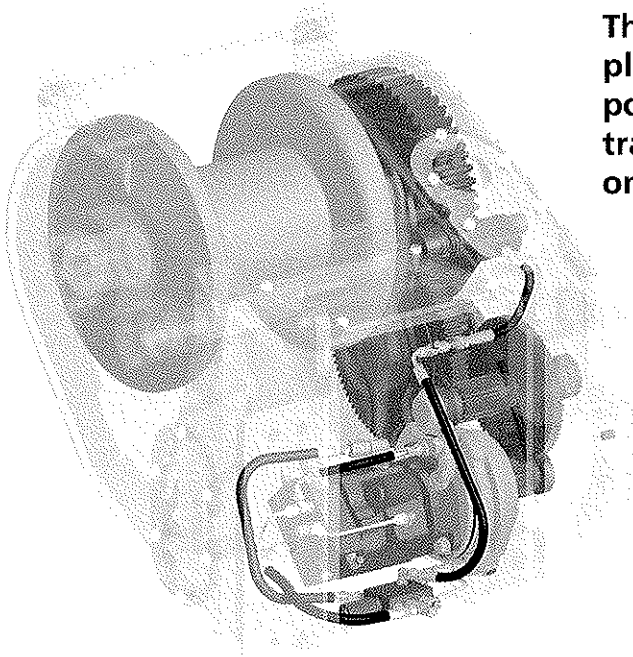

The H4A, an all-new hydraulic winch for simple field installation. Complete with all components to install on any 70-100 Hp track-type tractor. No need for "winch ready" package on tractor.

- Excels at precision control
- Two-speed motor
- One low-effort lever controls all functions: Brake-On, Power-In, Power-Out and Freespool

Features

- Motor turns only on demand—less wear and tear, quiet operation
- Single lever, finger-tip control
- Large cable capacity drum with increased throat clearance
- Welded steel frame with bolt-on attachments and for easy installation
- Two gear ratios available
- Large covers for easy service access

Options

- Four-roller fairlead, bolt-on
- Arch, bolt-on; two-way adjustable (back tilt and roller height)
- Drawbar, bolt-on
- Slow gear ratio
- H4AH High Performance (Hi-P) winch for frequent high speed, high line pull production work, such as logging
- Lower-cost H4AT Rescue winch for slow speed, high line pull equipment rescue applications

