



State of West Virginia
 Department of Administration
 Purchasing Division
 2019 Washington Street East
 Post Office Box 50130
 Charleston, WV 25305-0130

Request for Quotation

RFQ NUMBER
7011EC06

PAGE
1

ADDRESS CORRESPONDENCE TO ATTENTION OF:
BUYER 33 304-558-2402

VENDOR

*709051756 304-346-5301
 WV TRACTOR COMPANY
 PO BOX 473

 CHARLESTON WV 25322

SHIP TO

DIVISION OF HIGHWAYS
 EQUIPMENT DIVISION
 ROUTE 33
 BRUSHY FORK ROAD
 BUCKHANNON, WV
 26201 304-472-1750

DATE PRINTED	TERMS OF SALE	SHIP VIA	F.O.B.	FREIGHT TERMS
09/29/2010	Net 30 Days	Truck	Buckhannon	Prepaid
BID OPENING DATE: 11/10/2010		BID OPENING TIME 01:30PM		

LINE	QUANTITY	UOP	CAT NO.	ITEM NUMBER	UNIT PRICE	AMOUNT
0001	1	EA		760-06		
<p>75 HORSEPOWER TRACTOR/DOZER WITH WINCH AND BLADE</p> <p>OPEN END CONTRACT</p> <p>TO PROVIDE 75 HORSEPOWER TRACTOR/DOZER WITH WINCH AND BLADE FOR THE WEST VIRGINIA DIVISION OF HIGHWAYS. PER THE ATTACHED SPECIFICATIONS.</p> <p>MANDATORY PRE-BID</p> <p>A MANDATORY PRE-BID WILL BE HELD ON THURSDAY, 10/28 AT 11AM, 2019 WASHINGTON ST E., CHARLESTON WV 25305. ALL INTERESTED PARTIES ARE REQUIRED TO ATTEND THIS MEETING FAILURE TO ATTEND THE MANDATORY PRE-BID SHALL RESULT IN DISQUALIFICATION OF THE BID. NO ONE PERSON MAY REPRESENT MORE THAN ONE BIDDER.</p> <p>AN ATTENDANCE SHEET WILL BE MADE AVAILABLE FOR ALL POTENTIAL BIDDERS TO COMPLETE. THIS WILL SERVE AS THE OFFICIAL DOCUMENT VERIFYING ATTENDANCE AT THE MANDATORY PRE-BID. FAILURE TO PROVIDE YOUR COMPANY AND REPRESENTATIVE NAME ON THE ATTENDANCE SHEET WILL RESULT IN DISQUALIFICATION OF THE BID. THE STATE WILL NOT ACCEPT ANY OTHER DOCUMENTATION TO VERIFY ATTENDANCE. THE BIDDER IS RESPONSIBLE FOR ENSURING THEY HAVE COMPLETED THE INFORMATION REQUIRED ON THE ATTENDANCE SHEET. THE PURCHASING DIVISION AND THE STATE AGENCY WILL NOT ASSUME ANY RESPONSIBILITY FOR A BIDDER-S FAILURE TO COMPLETE THE PRE-BID ATTENDANCE SHEET. IN ADDITION, WE REQUEST THAT ALL POTENTIAL BIDDERS INCLUDE THEIR E-MAIL ADDRESS AND FAX NUMBER.</p>						

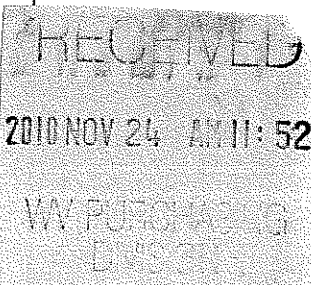

SEE REVERSE SIDE FOR TERMS AND CONDITIONS

SIGNATURE	TELEPHONE 346-5301	DATE 11/23/10
TITLE President	FAX 550621655	

ADDRESS CHANGES TO BE NOTED ABOVE

WHEN RESPONDING TO RFQ, INSERT NAME AND ADDRESS IN SPACE ABOVE LABELED 'VENDOR'

GENERAL TERMS & CONDITIONS
REQUEST FOR QUOTATION (RFQ) AND REQUEST FOR PROPOSAL (RFP)

1. Awards will be made in the best interest of the State of West Virginia.
2. The State may accept or reject in part, or in whole, any bid.
3. Prior to any award, the apparent successful vendor must be properly registered with the Purchasing Division and have paid the required \$125 fee.
4. All services performed or goods delivered under State Purchase Order/Contracts are to be continued for the term of the Purchase Order/Contracts, contingent upon funds being appropriated by the Legislature or otherwise being made available. In the event funds are not appropriated or otherwise available for these services or goods this Purchase Order/Contract becomes void and of no effect after June 30.
5. Payment may only be made after the delivery and acceptance of goods or services.
6. Interest may be paid for late payment in accordance with the *West Virginia Code*.
7. Vendor preference will be granted upon written request in accordance with the *West Virginia Code*.
8. The State of West Virginia is exempt from federal and state taxes and will not pay or reimburse such taxes.
9. The Director of Purchasing may cancel any Purchase Order/Contract upon 30 days written notice to the seller.
10. The laws of the State of West Virginia and the *Legislative Rules* of the Purchasing Division shall govern the purchasing process.
11. Any reference to automatic renewal is hereby deleted. The Contract may be renewed only upon mutual written agreement of the parties.
12. **BANKRUPTCY:** In the event the vendor/contractor files for bankruptcy protection, the State may deem this contract null and void, and terminate such contract without further order.
13. **HIPAA BUSINESS ASSOCIATE ADDENDUM:** The West Virginia State Government HIPAA Business Associate Addendum (BAA), approved by the Attorney General, is available online at www.state.wv.us/admin/purchase/vrc/hipaa.htm and is hereby made part of the agreement. Provided that the Agency meets the definition of a Cover Entity (45 CFR §160.103) and will be disclosing Protected Health Information (45 CFR §160.103) to the vendor.
14. **CONFIDENTIALITY:** The vendor agrees that he or she will not disclose to anyone, directly or indirectly, any such personally identifiable information or other confidential information gained from the agency, unless the individual who is the subject of the information consents to the disclosure in writing or the disclosure is made pursuant to the agency's policies, procedures, and rules. Vendor further agrees to comply with the Confidentiality Policies and Information Security Accountability Requirements, set forth in <http://www.state.wv.us/admin/purchase/privacy/noticeConfidentiality.pdf>.
15. **LICENSING:** Vendors must be licensed and in good standing in accordance with any and all state and local laws and requirements by any state or local agency of West Virginia, including, but not limited to, the West Virginia Secretary of State's Office, the West Virginia Tax Department, and the West Virginia Insurance Commission. The vendor must provide all necessary releases to obtain information to enable the director or spending unit to verify that the vendor is licensed and in good standing with the above entities.
16. **ANTITRUST:** In submitting a bid to any agency for the State of West Virginia, the bidder offers and agrees that if the bid is accepted the bidder will convey, sell, assign or transfer to the State of West Virginia all rights, title and interest in and to all causes of action it may now or hereafter acquire under the antitrust laws of the United States and the State of West Virginia for price fixing and/or unreasonable restraints of trade relating to the particular commodities or services purchased or acquired by the State of West Virginia. Such assignment shall be made and become effective at the time the purchasing agency tenders the initial payment to the bidder.

I certify that this bid is made without prior understanding, agreement, or connection with any corporation, firm, limited liability company, partnership, or person or entity submitting a bid for the same material, supplies, equipment or services and is in all respects fair and without collusion or fraud. I further certify that I am authorized to sign the certification on behalf of the bidder or this bid.

INSTRUCTIONS TO BIDDERS

1. Use the quotation forms provided by the Purchasing Division. Complete all sections of the quotation form.
2. Items offered must be in compliance with the specifications. Any deviation from the specifications must be clearly indicated by the bidder. Alternates offered by the bidder as **EQUAL** to the specifications must be clearly defined. A bidder offering an alternate should attach complete specifications and literature to the bid. The Purchasing Division may waive minor deviations to specifications.
3. Unit prices shall prevail in case of discrepancy. All quotations are considered F.O.B. destination unless alternate shipping terms are clearly identified in the quotation.
4. All quotations must be delivered by the bidder to the office listed below prior to the date and time of the bid opening. Failure of the bidder to deliver the quotations on time will result in bid disqualifications: Department of Administration, Purchasing Division, 2019 Washington Street East, P.O. Box 50130, Charleston, WV 25305-0130
5. Communication during the solicitation, bid, evaluation or award periods, except through the Purchasing Division, is strictly prohibited (W.Va. C.S.R. §148-1-6.6).



State of West Virginia
 Department of Administration
 Purchasing Division
 2019 Washington Street East
 Post Office Box 50130
 Charleston, WV 25305-0130

Request for Quotation

RFO NUMBER
7011EC06

PAGE
2

ADDRESS CORRESPONDENCE TO ATTENTION OF
BUYER 33 304-558-2402

*709051756 304-346-5301
 WV TRACTOR COMPANY
 PO BOX 473

CHARLESTON WV 25322

DIVISION OF HIGHWAYS
 EQUIPMENT DIVISION
 ROUTE 33
 BRUSHY FORK ROAD
 BUCKHANNON, WV
 26201 304-472-1750

VENDOR

SHIP TO

DATE PRINTED	TERMS OF SALE	SHIP VIA	FOB	FREIGHT TERMS
09/29/2010				

BID OPENING DATE: **11/10/2010** BID OPENING TIME **01:30PM**

LINE	QUANTITY	UOP	CAT NO	ITEM NUMBER	UNIT PRICE	AMOUNT
<p>ALL POTENTIAL BIDDERS ARE REQUESTED TO ARRIVE PRIOR TO THE STARTING TIME FOR THE PRE-BID. BIDDERS WHO ARRIVE LATE, BUT PRIOR TO THE DISMISSAL OF THE TECHNICAL PORTION OF THE PRE-BID WILL BE PERMITTED TO SIGN IN. BIDDERS WHO ARRIVE AFTER CONCLUSION OF THE TECHNICAL PORTION OF THE PRE-BID, BUT DURING ANY SUBSEQUENT PART OF THE PRE-BID WILL NOT BE PERMITTED TO SIGN THE ATTENDANCE SHEET.</p> <p>QUESTIONS: WRITTEN QUESTIONS WILL BE ACCEPTED THROUGH CLOSE OF BUSINESS (5:00 PM, EST) ON THURSDAY, 10/21/10.</p> <p>SEND QUESTIONS TO: PURCHASING DIVISION ATTENTION SHERI SLONE/CHUCK BOWMAN 2019 WASHINGTON STREET EAST CHARLESTON, WV 25305</p> <p>QUESTIONS MAY BE SENT VIA FAX, E-MAIL, OR REGULAR MAIL. E-MAIL: SHERI.D.SLONE@WV.GOV FAX: 304-558-4115</p> <p>IT IS THE VENDOR'S RESPONSIBILITY TO VERIFY THAT THEIR QUESTIONS HAVE BEEN RECEIVED BY CALLING 304-558-2402.</p> <p>EXHIBIT 2</p> <p>LIFE OF CONTRACT: THIS CONTRACT BECOMES EFFECTIVE ON AND EXTENDS FOR A PERIOD OF ONE (1) YEAR OR UNTIL SUCH "REASONABLE TIME" THEREAFTER AS IS NECESSARY TO OBTAIN A NEW CONTRACT OR RENEW THE ORIGINAL CONTRACT. THE "REASONABLE TIME" PERIOD SHALL NOT EXCEED TWELVE (12) MONTHS. DURING THIS "REASONABLE TIME" THE VENDOR MAY TERMINATE THIS CONTRACT FOR</p>						

SEE REVERSE SIDE FOR TERMS AND CONDITIONS

SIGNATURE	TELEPHONE	DATE
TITLE	FEIN	ADDRESS CHANGES TO BE NOTED ABOVE

WHEN RESPONDING TO RFQ, INSERT NAME AND ADDRESS IN SPACE ABOVE LABELED 'VENDOR'



State of West Virginia
 Department of Administration
 Purchasing Division
 2019 Washington Street East
 Post Office Box 50130
 Charleston, WV 25305-0130

Request for Quotation

RFQ NUMBER
7011EC06

PAGE
3

ADDRESS CORRESPONDENCE TO ATTENTION OF
BUYER 33
304-558-2402

VENDOR

*709051756 304-346-5301
 WV TRACTOR COMPANY
 PO BOX 473
 CHARLESTON WV 25322

SHIP TO

DIVISION OF HIGHWAYS
 EQUIPMENT DIVISION
 ROUTE 33
 BRUSHY FORK ROAD
 BUCKHANNON, WV
 26201 304-472-1750

DATE PRINTED	TERMS OF SALE	SHIP VIA	F.O.B.	FREIGHT TERMS
09/29/2010				

BID OPENING DATE: **11/10/2010** BID OPENING TIME **01:30PM**

LINE	QUANTITY	UOP	CAT NO	ITEM NUMBER	UNIT PRICE	AMOUNT
<p>ANY REASON UPON GIVING THE DIRECTOR OF PURCHASING THIRTY (30) DAYS WRITTEN NOTICE.</p> <p>UNLESS SPECIFIC PROVISIONS ARE STIPULATED IN THIS CONTRACT DOCUMENT, THE TERMS, CONDITIONS, AND PRICING SET HEREIN ARE FIRM FOR THE LIFE OF THE CONTRACT.</p> <p>RENEWAL: THIS CONTRACT MAY BE RENEWED UPON THE MUTUAL WRITTEN CONSENT OF THE SPENDING UNIT AND VENDOR, SUBMITTED TO THE DIRECTOR OF PURCHASING THIRTY (30) DAYS PRIOR TO THE EXPIRATION DATE. SUCH RENEWAL SHALL BE IN ACCORDANCE WITH THE TERMS AND CONDITIONS OF THE ORIGINAL CONTRACT AND SHALL BE LIMITED TO TWO (2) ONE (1) YEAR PERIODS.</p> <p>CANCELLATION: THE DIRECTOR OF PURCHASING RESERVES THE RIGHT TO CANCEL THIS CONTRACT IMMEDIATELY UPON WRITTEN NOTICE TO THE VENDOR IF THE COMMODITIES AND/OR SERVICE SUPPLIED ARE OF AN INFERIOR QUALITY OR DO NOT CONFORM WITH THE SPECIFICATIONS OF THE BID AND CONTRACT HEREIN.</p> <p>OPEN MARKET CLAUSE: THE DIRECTOR OF PURCHASING MAY AUTHORIZE A SPENDING UNIT TO PURCHASE ON THE OPEN MARKET, WITHOUT THE FILING OF A REQUISITION OR COST ESTIMATE, ITEMS SPECIFIED ON THIS CONTRACT FOR IMMEDIATE DELIVERY IN EMERGENCIES DUE TO UNFORESEEN CAUSES (INCLUDING BUT NOT LIMITED TO DELAYS IN TRANSPORTATION OR AN UNANTICIPATED INCREASE IN THE VOLUME OF WORK).</p> <p>QUANTITIES: QUANTITIES LISTED IN THE REQUISITION ARE APPROXIMATIONS ONLY, BASED ON ESTIMATES SUPPLIES BY THE STATE SPENDING UNIT. IT IS UNDERSTOOD AND AGREED THAT THE CONTRACT SHALL COVER THE QUANTITIES ACTUALLY ORDERED FOR DELIVERY DURING THE TERM OF CONTRACT, WHETHER MORE OR LESS THAN THE QUANTITIES SHOWN.</p>						

SEE REVERSE SIDE FOR TERMS AND CONDITIONS

SIGNATURE	TELEPHONE	DATE
TITLE	FEIN	ADDRESS CHANGES TO BE NOTED ABOVE

WHEN RESPONDING TO RFQ, INSERT NAME AND ADDRESS IN SPACE ABOVE LABELED 'VENDOR'



State of West Virginia
 Department of Administration
 Purchasing Division
 2019 Washington Street East
 Post Office Box 50130
 Charleston, WV 25305-0130

**Request for
 Quotation**

RFQ NUMBER
7011EC06

PAGE
4

ADDRESS CORRESPONDENCE TO ATTENTION OF:
BUYER 33 304-558-2402

VENDOR
 *709051756 304-346-5301
 WV TRACTOR COMPANY
 PO BOX 473
 CHARLESTON WV 25322

SHIP TO
 DIVISION OF HIGHWAYS
 EQUIPMENT DIVISION
 ROUTE 33
 BRUSHY FORK ROAD
 BUCKHANNON, WV
 26201 304-472-1750

DATE PRINTED	TERMS OF SALE	SHIP VIA	F.O.B.	FREIGHT TERMS
09/29/2010				

BID OPENING DATE: 11/10/2010 BID OPENING TIME: 01:30PM

LINE	QUANTITY	UOP	CAT NO	ITEM NUMBER	UNIT PRICE	AMOUNT
<p>ORDERING PROCEDURE: SPENDING UNIT(S) SHALL ISSUE A WRITTEN EQUIPMENT CONTRACT ORDER (FORM NUMBER WV-35) FOR COMMODITIES COVERED BY THIS CONTRACT. THE ORIGINAL WV-35 MUST BE SENT TO THE PURCHASING DIVISION OF THE DEPARTMENT OF ADMINISTRATION. AFTER APPROVAL AND ENCUMBRANCE, ONE COPY OF THE PURCHASE ORDER WILL BE RETURNED TO THE SPENDING UNIT AND ONE COPY FORWARDED TO THE VENDOR AS AUTHORIZATION FOR SHIPMENT. NO ORDER IS VALID UNLESS APPROVED AND ENCUMBERED BY THE PURCHASING DIVISION.</p> <p>BANKRUPTCY: IN THE EVENT THE VENDOR/CONTRACTOR FILES FOR BANKRUPTCY PROTECTION, THE STATE MAY DEEM THE CONTRACT NULL AND VOID, AND TERMINATE SUCH CONTRACT WITHOUT FUTHER ORDER.</p> <p>REV. 5/2009</p> <p>EXHIBIT 10</p> <p>7011EC06</p> <p>REQUISITION NO.:</p> <p>ADDENDUM ACKNOWLEDGEMENT</p> <p>I HEREBY ACKNOWLEDGE RECEIPT OF THE FOLLOWING CHECKED ADDENDUM(S) AND HAVE MADE THE NECESSARY REVISIONS TO MY PROPOSAL, PLANS AND/OR SPECIFICATION, ETC.</p> <p>ADDENDUM NO.'S:</p> <p>NO. 1 .X.....</p> <p>NO. 2 .X.....</p> <p>NO. 3 .X.....</p>						

SEE REVERSE SIDE FOR TERMS AND CONDITIONS			
SIGNATURE	TELEPHONE	DATE	
TITLE	FEIN	ADDRESS CHANGES TO BE NOTED ABOVE	

WHEN RESPONDING TO RFQ, INSERT NAME AND ADDRESS IN SPACE ABOVE LABELED 'VENDOR'



State of West Virginia
 Department of Administration
 Purchasing Division
 2019 Washington Street East
 Post Office Box 50130
 Charleston, WV 25305-0130

Request for Quotation

RFQ NUMBER
7011EC06

PAGE
5

ADDRESS CORRESPONDENCE TO ATTENTION OF
BUYER 33
304-558-2402

VENDOR

*709051756 304-346-5301
 WV TRACTOR COMPANY
 PO BOX 473
 CHARLESTON WV 25322

SHIP TO

DIVISION OF HIGHWAYS
 EQUIPMENT DIVISION
 ROUTE 33
 BRUSHY FORK ROAD
 BUCKHANNON, WV
 26201 304-472-1750

DATE PRINTED	TERMS OF SALE	SHIP VIA	F.O.B.	FREIGHT TERMS
09/29/2010				

BID OPENING DATE: **11/10/2010** BID OPENING TIME **01:30PM**

LINE	QUANTITY	UOP	CAT NO	ITEM NUMBER	UNIT PRICE	AMOUNT
	NO. 4 ..X.....					
	NO. 5					
<p>I UNDERSTAND THAT FAILURE TO CONFIRM THE RECEIPT OF TH ADDENDUM(S) MAY BE CAUSE FOR REJECTION OF BIDS.</p> <p>VENDOR MUST CLEARLY UNDERSTAND THAT ANY VERBAL REPRESENTATION MADE OR ASSUMED TO BE MADE DURING ANY ORAL DISCUSSION HELD BETWEEN VENDOR'S REPRESENTATIVES AND ANY STATE PERSONNEL IS NOT BINDING. ONLY THE INFORMATION ISSUED IN WRITING AND ADDED TO THE SPECIFICATIONS BY AN OFFICIAL ADDENDUM IS BINDING.</p> <p style="text-align: center;"><i>George Gray</i> SIGNATURE</p> <p style="text-align: center;">..... West Virginia Tractor Company COMPANY</p> <p style="text-align: center;">11/23/10 DATE</p> <p>NOTE: THIS ADDENDUM ACKNOWLEDGEMENT SHOULD BE SUBMITTED WITH THE BID.</p> <p>REV. 09/21/2009</p> <p>EXHIBIT 4</p> <p>LOCAL GOVERNMENT BODIES: UNLESS THE VENDOR INDICATES IN THE BID HIS REFUSAL TO EXTEND THE PRICES, TERMS, AND CONDITIONS OF THE BID TO COUNTY, SCHOOL, MUNICIPAL</p>						

SEE REVERSE SIDE FOR TERMS AND CONDITIONS

SIGNATURE	TELEPHONE	DATE
TITLE	FEIN	ADDRESS CHANGES TO BE NOTED ABOVE

WHEN RESPONDING TO RFQ, INSERT NAME AND ADDRESS IN SPACE ABOVE LABELED 'VENDOR'



State of West Virginia
 Department of Administration
 Purchasing Division
 2019 Washington Street East
 Post Office Box 50130
 Charleston, WV 25305-0130

Request for Quotation

RFQ NUMBER
7011EC06

PAGE
6

ADDRESS CORRESPONDENCE TO ATTENTION OF
BUYER 33 304-558-2402

VENDOR
*709051756 304-346-5301 WV TRACTOR COMPANY PO BOX 473 CHARLESTON WV 25322

SHIP TO
DIVISION OF HIGHWAYS EQUIPMENT DIVISION ROUTE 33 BRUSHY FORK ROAD BUCKHANNON, WV 26201 304-472-1750

DATE PRINTED	TERMS OF SALE	SHIP VIA	F.O.B.	FREIGHT TERMS
09/29/2010				

BID OPENING DATE: 11/10/2010 BID OPENING TIME 01:30PM

LINE	QUANTITY	UOP	CAT NO	ITEM NUMBER	UNIT PRICE	AMOUNT
<p>AND OTHER LOCAL GOVERNMENT BODIES, THE BID SHALL EXTEND TO POLITICAL SUBDIVISIONS OF THE STATE OF WEST VIRGINIA. IF THE VENDOR DOES NOT WISH TO EXTEND THE PRICES, TERMS, AND CONDITIONS OF THE BID TO ALL POLITICAL SUBDIVISIONS OF THE STATE, THE VENDOR MUST CLEARLY INDICATE SUCH REFUSAL IN HIS BID. SUCH REFUSAL SHALL NOT PREJUDICE THE AWARD OF THIS CONTRACT IN ANY MANNER.</p> <p>REV. 3/88</p> <p style="text-align: center;">NOTICE</p> <p>A SIGNED BID MUST BE SUBMITTED TO:</p> <p style="text-align: center;">DEPARTMENT OF ADMINISTRATION PURCHASING DIVISION BUILDING 15 2019 WASHINGTON STREET, EAST CHARLESTON, WV 25305-0130</p> <p>THE BID SHOULD CONTAIN THIS INFORMATION ON THE FACE OF THE ENVELOPE OR THE BID MAY NOT BE CONSIDERED:</p> <p>SEALED BID</p> <p>BUYER: 33</p> <p>RFQ. NO.: 7011EC06</p> <p>BID OPENING DATE: 11/10/2010</p>						

SEE REVERSE SIDE FOR TERMS AND CONDITIONS			
SIGNATURE	TELEPHONE	DATE	
TITLE	FEIN	ADDRESS CHANGES TO BE NOTED ABOVE	

WHEN RESPONDING TO RFQ, INSERT NAME AND ADDRESS IN SPACE ABOVE LABELED 'VENDOR'



State of West Virginia
 Department of Administration
 Purchasing Division
 2019 Washington Street East
 Post Office Box 50130
 Charleston, WV 25305-0130

Request for Quotation

RFQ NUMBER
7011EC06

PAGE
7

ADDRESS CORRESPONDENCE TO ATTENTION OF:
BUYER 33 304-558-2402

VENDOR

*709051756 304-346-5301
 WV TRACTOR COMPANY
 PO BOX 473
 CHARLESTON WV 25322

SHIP TO

DIVISION OF HIGHWAYS
 EQUIPMENT DIVISION
 ROUTE 33
 BRUSHY FORK ROAD
 BUCKHANNON, WV
 26201 304-472-1750

DATE PRINTED	TERMS OF SALE	SHIP VIA	FOB	FREIGHT TERMS
09/29/2010				

BID OPENING DATE: 11/10/2010 BID OPENING TIME 01:30PM

LINE	QUANTITY	UOP	CAT NO	ITEM NUMBER	UNIT PRICE	AMOUNT
BID OPENING TIME:				1:30 PM		
PLEASE PROVIDE A FAX NUMBER IN CASE IT IS NECESSARY TO CONTACT YOU REGARDING YOUR BID:						
				346-5305		

CONTACT PERSON (PLEASE PRINT CLEARLY):						
				Gary Grady		

***** THIS IS THE END OF RFQ 7011EC06 ***** TOTAL:						_____

SEE REVERSE SIDE FOR TERMS AND CONDITIONS

SIGNATURE	TELEPHONE	DATE
TITLE	FEIN	ADDRESS CHANGES TO BE NOTED ABOVE

WHEN RESPONDING TO RFQ, INSERT NAME AND ADDRESS IN SPACE ABOVE LABELED 'VENDOR'



State of West Virginia
 Department of Administration
 Purchasing Division
 2019 Washington Street East
 Post Office Box 50130
 Charleston, WV 25305-0130

Request for Quotation

RFQ NUMBER
 7011EC06

PAGE
 1

ADDRESS CORRESPONDENCE TO ATTENTION OF:
 BUYER 33
 304-558-2402

VENDOR

RFQ COPY
 TYPE NAME/ADDRESS HERE

West Virginia Tractor Company
 P.O. Box 473
 Charleston, WV 25322

SHIP TO

DIVISION OF HIGHWAYS
 EQUIPMENT DIVISION
 ROUTE 33
 BRUSHY FORK ROAD
 BUCKHANNON, WV
 26201 304-472-1750

DATE PRINTED	TERMS OF SALE	SHIP VIA	F.O.B.	FREIGHT TERMS
10/15/2010	Net 30 DAsy	Truck	Buckhannon	Prepaid

LINE	QUANTITY	UGP	CAT NO	ITEM NUMBER	BID OPENING TIME	UNIT PRICE	AMOUNT
					11/17/2010	01:30PM	

ADDENDUM NO. 1

THIS ADDENDUM IS ISSUED TO:

1.) TO CHANGE THE DATE AND TIME FOR THE MANDATORY PRE-BID MEETING,

MANDATORY PRE-BID DATE: 11/03/2010
 MANDATORY PRE-BID TIME: 9:00 AM

PRE-BID WILL BE HELD AT:

WV STATE PURCHASING DIVISION
 2019 WASHINGTON STREET, EAST
 CHARLESTON, WV 25305
 (BUILDING #15)

2.) TO EXTEND THE DEADLINE FOR TECHNICAL QUESTIONS,

DEADLINE FOR TECHNICAL QUESTIONS: 10/28/2010 AT THE CLOSE OF BUSINESS (5:00 PM)

3.) EXTEND THE BID OPENING DATE

BID OPENING DATE IS EXTENDED TO: 11/17/2010
 BID OPENING TIME REMAINS: 1:30 PM

***** END ADDENDUM NO. 1 *****

SEE REVERSE SIDE FOR TERMS AND CONDITIONS			
SIGNATURE <i>Paul W. Gray</i>	TELEPHONE 346-5301	DATE 11/23/10	
TITLE President	FEIN 550621655	ADDRESS CHANGES TO BE NOTED ABOVE	

WHEN RESPONDING TO RFQ, INSERT NAME AND ADDRESS IN SPACE ABOVE LABELED 'VENDOR'



State of West Virginia
 Department of Administration
 Purchasing Division
 2019 Washington Street East
 Post Office Box 50130
 Charleston, WV 25305-0130

Request for Quotation

RFQ NUMBER
7011EC06

PAGE
1

ADDRESS CORRESPONDENCE TO ATTENTION OF
BUYER 33 304-558-2402

VENDOR
*709051756 304-346-5301 WV TRACTOR COMPANY PO BOX 473 CHARLESTON WV 25322

SHIP TO
DIVISION OF HIGHWAYS EQUIPMENT DIVISION ROUTE 33 BRUSHY FORK ROAD BUCKHANNON, WV 26201 304-472-1750

DATE PRINTED	TERMS OF SALE	SHIP VIA	F.O.B	FREIGHT TERMS
11/16/2010	Net 30 Days	Truck	Buckhannon	Prepaid

BID OPENING DATE: 11/17/2010 BID OPENING TIME 01:30PM

LINE	QUANTITY	UOP	CAT NO.	ITEM NUMBER	UNIT PRICE	AMOUNT
ADDENDUM NO. 2						
THIS ADDENDUM IS ISSUED TO ADDRESS SPECIFICATION CHANGES AS DISCUSSED AND AGREED UPON DURING MANDATORY PRE-BID MEETING PER ATTACHED.						
BID OPENING DATE REMAINS: 11/17/2010						
BID OPENING TIME REMAINS: 1:30 PM						
***** END ADDENDUM NO. 2 *****						
0001	1	EA		760-06		
75 HORSEPOWER TRACTOR/DOZER WITH WINCH AND BLADE						
***** THIS IS THE END OF RFQ 7011EC06 ***** TOTAL:						

SEE REVERSE SIDE FOR TERMS AND CONDITIONS

SIGNATURE <i>Gayle Gray</i>	TELEPHONE 346-5301	DATE 11/23/10
TITLE President	FEIN 550621655	ADDRESS CHANGES TO BE NOTED ABOVE

WHEN RESPONDING TO RFQ, INSERT NAME AND ADDRESS IN SPACE ABOVE LABELED 'VENDOR'

GENERAL TERMS & CONDITIONS
REQUEST FOR QUOTATION (RFQ) AND REQUEST FOR PROPOSAL (RFP)

1. Awards will be made in the best interest of the State of West Virginia.
2. The State may accept or reject in part, or in whole, any bid.
3. Prior to any award, the apparent successful vendor must be properly registered with the Purchasing Division and have paid the required \$125 fee.
4. All services performed or goods delivered under State Purchase Order/Contracts are to be continued for the term of the Purchase Order/Contracts, contingent upon funds being appropriated by the Legislature or otherwise being made available. In the event funds are not appropriated or otherwise available for these services or goods this Purchase Order/Contract becomes void and of no effect after June 30.
5. Payment may only be made after the delivery and acceptance of goods or services.
6. Interest may be paid for late payment in accordance with the *West Virginia Code*.
7. Vendor preference will be granted upon written request in accordance with the *West Virginia Code*.
8. The State of West Virginia is exempt from federal and state taxes and will not pay or reimburse such taxes.
9. The Director of Purchasing may cancel any Purchase Order/Contract upon 30 days written notice to the seller.
10. The laws of the State of West Virginia and the *Legislative Rules* of the Purchasing Division shall govern the purchasing process.
11. Any reference to automatic renewal is hereby deleted. The Contract may be renewed only upon mutual written agreement of the parties.
12. **BANKRUPTCY:** In the event the vendor/contractor files for bankruptcy protection, the State may deem this contract null and void, and terminate such contract without further order.
13. **HIPAA BUSINESS ASSOCIATE ADDENDUM:** The West Virginia State Government HIPAA Business Associate Addendum (BAA), approved by the Attorney General, is available online at www.state.wv.us/admin/purchase/vrc/hipaa.htm and is hereby made part of the agreement. Provided that the Agency meets the definition of a Cover Entity (45 CFR §160.103) and will be disclosing Protected Health Information (45 CFR §160.103) to the vendor.
14. **CONFIDENTIALITY:** The vendor agrees that he or she will not disclose to anyone, directly or indirectly, any such personally identifiable information or other confidential information gained from the agency, unless the individual who is the subject of the information consents to the disclosure in writing or the disclosure is made pursuant to the agency's policies, procedures, and rules. Vendor further agrees to comply with the Confidentiality Policies and Information Security Accountability Requirements, set forth in <http://www.state.wv.us/admin/purchase/privacy/noticeConfidentiality.pdf>.
15. **LICENSING:** Vendors must be licensed and in good standing in accordance with any and all state and local laws and requirements by any state or local agency of West Virginia, including, but not limited to, the West Virginia Secretary of State's Office, the West Virginia Tax Department, and the West Virginia Insurance Commission. The vendor must provide all necessary releases to obtain information to enable the director or spending unit to verify that the vendor is licensed and in good standing with the above entities.
16. **ANTITRUST:** In submitting a bid to any agency for the State of West Virginia, the bidder offers and agrees that if the bid is accepted the bidder will convey, sell, assign or transfer to the State of West Virginia all rights, title and interest in and to all causes of action it may now or hereafter acquire under the antitrust laws of the United States and the State of West Virginia for price fixing and/or unreasonable restraints of trade relating to the particular commodities or services purchased or acquired by the State of West Virginia. Such assignment shall be made and become effective at the time the purchasing agency tenders the initial payment to the bidder.

I certify that this bid is made without prior understanding, agreement, or connection with any corporation, firm, limited liability company, partnership, or person or entity submitting a bid for the same material, supplies, equipment or services and is in all respects fair and without collusion or Fraud. I further certify that I am authorized to sign the certification on behalf of the bidder or this bid.

INSTRUCTIONS TO BIDDERS

1. Use the quotation forms provided by the Purchasing Division. Complete all sections of the quotation form.
2. Items offered must be in compliance with the specifications. Any deviation from the specifications must be clearly indicated by the bidder. Alternates offered by the bidder as **EQUAL** to the specifications must be clearly defined. A bidder offering an alternate should attach complete specifications and literature to the bid. The Purchasing Division may waive minor deviations to specifications.
3. Unit prices shall prevail in case of discrepancy. All quotations are considered F.O.B. destination unless alternate shipping terms are clearly identified in the quotation.
4. All quotations must be delivered by the bidder to the office listed below prior to the date and time of the bid opening. Failure of the bidder to deliver the quotations on time will result in bid disqualifications: Department of Administration, Purchasing Division, 2019 Washington Street East, P.O. Box 50130, Charleston, WV 25305-0130
5. Communication during the solicitation, bid, evaluation or award periods, except through the Purchasing Division, is strictly prohibited (W.Va. C.S.R. §148-1-6.6).



State of West Virginia
 Department of Administration
 Purchasing Division
 2019 Washington Street East
 Post Office Box 50130
 Charleston, WV 25305-0130

Request for Quotation

RFQ NUMBER
7011EC06

PAGE
1

ADDRESS CORRESPONDENCE TO ATTENTION OF
BUYER 33 304-558-2402

VENDOR

RFQ COPY

TYPE NAME/ADDRESS HERE

West Virginia Tractor Company
 P.O. Box 473
 Charleston, WV 25322

DIVISION OF HIGHWAYS
 EQUIPMENT DIVISION
 ROUTE 33
 BRUSHY FORK ROAD
 BUCKHANNON, WV
 26201 304-472-1750

DATE PRINTED	TERMS OF SALE	SHIP VIA	F.O.B.	FREIGHT TERMS
11/16/2010	Net 30 Days	Truck	Buckhannon	Prepaid

BID OPENING DATE: 11/24/2010 BID OPENING TIME 01:30PM

LINE	QUANTITY	UOP	CAT NO	ITEM NUMBER	UNIT PRICE	AMOUNT
ADDENDUM NO. 3						
THIS ADDENDUM IS ISSUED TO:						
EXTEND BID OPENING DATE: 11/24/2010						
EXTEND BID OPENING TIME: 1:30 PM						
*****END ADDENDUM NO 3*****						
0001	1	EA		750-06		
75 HORSEPOWER TRACTOR/DOZER WITH WINCH AND BLADE						
***** THIS IS THE END OF RFQ 7011EC06 ***** TOTAL:						

SEE REVERSE SIDE FOR TERMS AND CONDITIONS

SIGNATURE <i>Gaule Knox</i>	TELEPHONE 346-5301	DATE 11/23/10
TITLE President	FEIN 550621655	ADDRESS CHANGES TO BE NOTED ABOVE

WHEN RESPONDING TO RFQ, INSERT NAME AND ADDRESS IN SPACE ABOVE LABELED 'VENDOR'



State of West Virginia
 Department of Administration
 Purchasing Division
 2019 Washington Street East
 Post Office Box 50130
 Charleston, WV 25305-0130

Request for Quotation

RFQ NUMBER
7011EC06

PAGE
1

ADDRESS CORRESPONDENCE TO ATTENTION OF
BUYER 33 304-558-2402

VENDOR
709051756 304-346-5301 WV TRACTOR COMPANY PO BOX 473 CHARLESTON WV 25322

SHIP TO
DIVISION OF HIGHWAYS EQUIPMENT DIVISION ROUTE 33 BRUSHY FORK ROAD BUCKHANNON, WV 26201 304-472-1750

DATE PRINTED	TERMS OF SALE	SHIP VIA	F.O.B.	FREIGHT TERMS
11/22/2010	Net 30 Days	Truck	Buckhannon	Prepaid
BID OPENING DATE:	11/24/2010	BID OPENING TIME		01:30PM

LINE	QUANTITY	UOP	CAT. NO.	ITEM NUMBER	UNIT PRICE	AMOUNT
ADDENDUM NO 4						
THIS ADDENDUM IS ISSUED TO ADDRESS CORRECTION TO ITEM 7.5.4 OF SPECIFICATION, PER ATTACHED.						
*****END ADDENDUM NO 4*****						
0001	1	EA		760-06		
75 HORSEPOWER TRACTOR/DOZER WITH WINCH AND BLADE						
***** THIS IS THE END OF RFQ 7011EC06 ***** TOTAL:						

SEE REVERSE SIDE FOR TERMS AND CONDITIONS			
SIGNATURE	TELEPHONE	DATE	
<i>Gayle Gray</i>	346-5301	11/23/10	
TITLE	FEIN	ADDRESS CHANGES TO BE NOTED ABOVE	
President	590621655		

WHEN RESPONDING TO RFQ, INSERT NAME AND ADDRESS IN SPACE ABOVE LABELED 'VENDOR'

**GENERAL TERMS & CONDITIONS
REQUEST FOR QUOTATION (RFQ) AND REQUEST FOR PROPOSAL (RFP)**

1. Awards will be made in the best interest of the State of West Virginia.
2. The State may accept or reject in part, or in whole, any bid.
3. Prior to any award, the apparent successful vendor must be properly registered with the Purchasing Division and have paid the required \$125 fee.
4. All services performed or goods delivered under State Purchase Order/Contracts are to be continued for the term of the Purchase Order/Contracts, contingent upon funds being appropriated by the Legislature or otherwise being made available. In the event funds are not appropriated or otherwise available for these services or goods this Purchase Order/Contract becomes void and of no effect after June 30.
5. Payment may only be made after the delivery and acceptance of goods or services.
6. Interest may be paid for late payment in accordance with the *West Virginia Code*.
7. Vendor preference will be granted upon written request in accordance with the *West Virginia Code*.
8. The State of West Virginia is exempt from federal and state taxes and will not pay or reimburse such taxes.
9. The Director of Purchasing may cancel any Purchase Order/Contract upon 30 days written notice to the seller.
10. The laws of the State of West Virginia and the *Legislative Rules* of the Purchasing Division shall govern the purchasing process.
11. Any reference to automatic renewal is hereby deleted. The Contract may be renewed only upon mutual written agreement of the parties.
12. **BANKRUPTCY:** In the event the vendor/contractor files for bankruptcy protection, the State may deem this contract null and void, and terminate such contract without further order.
13. **HIPAA BUSINESS ASSOCIATE ADDENDUM:** The West Virginia State Government HIPAA Business Associate Addendum (BAA), approved by the Attorney General, is available online at www.state.wv.us/admin/purchase/vrc/hipaa.htm and is hereby made part of the agreement. Provided that the Agency meets the definition of a Cover Entity (45 CFR §160.103) and will be disclosing Protected Health Information (45 CFR §160.103) to the vendor.
14. **CONFIDENTIALITY:** The vendor agrees that he or she will not disclose to anyone, directly or indirectly, any such personally identifiable information or other confidential information gained from the agency, unless the individual who is the subject of the information consents to the disclosure in writing or the disclosure is made pursuant to the agency's policies, procedures, and rules. Vendor further agrees to comply with the Confidentiality Policies and Information Security Accountability Requirements, set forth in <http://www.state.wv.us/admin/purchase/privacy/noticeConfidentiality.pdf>.
15. **LICENSING:** Vendors must be licensed and in good standing in accordance with any and all state and local laws and requirements by any state or local agency of West Virginia, including, but not limited to, the West Virginia Secretary of State's Office, the West Virginia Tax Department, and the West Virginia Insurance Commission. The vendor must provide all necessary releases to obtain information to enable the director or spending unit to verify that the vendor is licensed and in good standing with the above entities.
16. **ANTITRUST:** In submitting a bid to any agency for the State of West Virginia, the bidder offers and agrees that if the bid is accepted the bidder will convey, sell, assign or transfer to the State of West Virginia all rights, title and interest in and to all causes of action it may now or hereafter acquire under the antitrust laws of the United States and the State of West Virginia for price fixing and/or unreasonable restraints of trade relating to the particular commodities or services purchased or acquired by the State of West Virginia. Such assignment shall be made and become effective at the time the purchasing agency tenders the initial payment to the bidder.

I certify that this bid is made without prior understanding, agreement, or connection with any corporation, firm, limited liability company, partnership, or person or entity submitting a bid for the same material, supplies, equipment or services and is in all respects fair and without collusion or Fraud. I further certify that I am authorized to sign the certification on behalf of the bidder or this bid.

INSTRUCTIONS TO BIDDERS

1. Use the quotation forms provided by the Purchasing Division. Complete all sections of the quotation form.
2. Items offered must be in compliance with the specifications. Any deviation from the specifications must be clearly indicated by the bidder. Alternates offered by the bidder as **EQUAL** to the specifications must be clearly defined. A bidder offering an alternate should attach complete specifications and literature to the bid. The Purchasing Division may waive minor deviations to specifications.
3. Unit prices shall prevail in case of discrepancy. All quotations are considered F.O.B. destination unless alternate shipping terms are clearly identified in the quotation.
4. All quotations must be delivered by the bidder to the office listed below prior to the date and time of the bid opening. Failure of the bidder to deliver the quotations on time will result in bid disqualifications: Department of Administration, Purchasing Division, 2019 Washington Street East, P.O. Box 50130, Charleston, WV 25305-0130
5. Communication during the solicitation, bid, evaluation or award periods, except through the Purchasing Division, is strictly prohibited (W.Va. C.S.R. §148-1-6.6).

WEST VIRGINIA DEPARTMENT OF TRANSPORTATION
DIVISION OF HIGHWAYS
EQUIPMENT DIVISION

BIDDER'S EVALUATION REPORT

PROCUREMENT SPECIFICATIONS FOR OPEN END CONTRACT
NO. 300-2-D

OPEN END CONTRACT
75 HORSEPOWER TRACTOR/DOZER WITH WINCH AND BLADE

NOTE TO BIDDER: Procurement Specification No. 300-2-D, Paragraph 2.0 recommends the completion and submittal of this Report with your bid. Purpose of this Report is to enable the West Virginia Division of Highways Evaluation Committee to make full and fair evaluation of the bid. Addendums in order, along with a summary of exception as a separate attachment, should be with Bidder's Evaluation Report. FAILURE TO SUBMIT THIS REPORT, COMPLETE IN ITS ENTIRETY, MAY SUBJECT THE BIDDER TO DISQUALIFICATION.

Reference Requisition No.: 7011EC06

Bidder's Name: West Virginia Tractor Company

Address: P.O. Box 473 Charleston, WV 25322

Telephone Number: 346-5301

Years Bidder has been registered to do business with the State of West Virginia: 28 YRS.

Years Company has been an authorized dealer for proposed unit: -1 YRS.

X3.2 Have you complied with all mandatory specifications? YES NO

X4.2 DELIVERY:

X4.2.1 Delivery date of completed representative unit: 120 Calendar Days After
Receipt of Purchase Agreement

X4.2.2 Delivery date of balance of completed units: 180 Calendar Days After Receipt of
Purchase Agreement

X5.0 AWARD CRITERIA;

X5.1 Price per unit: \$103,990.00
_____ per unit

X6.0 SPECIFICATIONS - GENERAL

X6.1 Manufacturer, model, series, and date of manufacture of proposed unit:

__Dressta TD-7 Series R__ tractor and Allied H4HA winch 2011 or later as ordered

Is descriptive literature, fully describing proposed unit attached to your bid? YES _____ NO

If not, why? _____

X6.2 Will the required number of service manuals, and complete parts list be delivered to the Equipment Division at Buckhannon upon completion of delivery of total units?

YES _____ NO

Will the required Equipment Preventive Maintenance Form (Section X6.2 of Bidders Evaluation Report) be provided upon inspection of the pilot unit? YES _____ NO

X6.2
2-10-00

EQUIPMENT PREVENTATIVE MAINTENANCE QUESTIONNAIRE

THIS FORM MUST BE COMPLETED IN ITS ENTIRETY BY SUCCESSFUL BIDDER OR MANUFACTURER'S TECHNICAL REPRESENTATIVE PRIOR TO DELIVERY OF PILOT MODEL TO THE WVDOH.

DESCRIPTION: _____ MAKE: _____

MODEL: _____ YEAR: _____ PURCHASE AMOUNT: _____

ENGINE: MAKE: _____ MODEL: _____ FUEL TYPE: _____

HORSEPOWER: _____ CYLINDER: _____ ENGINE SERIAL: _____

COOLING SYSTEM CAPACITY: _____

BELTS: DESCRIPTION: _____ PART NUMBERS: _____

GVW: _____ AXLE CAPACITY: FRONT: _____ REAR: _____

TIRES: FRONT MAKE & SIZE: _____

REAR MAKE & SIZE: _____

DIMENSIONS OF UNIT: LENGTH: _____ WIDTH: _____ LENGTH: _____

VENDOR CONTACT PERSON: _____ PHONE: _____

PARTS:

BATTERY MAKE: _____ MODEL: _____ CCA: _____

TOP OR SIDE POST: _____ DIMENSIONS: LENGTH _____ WIDTH _____ HEIGHT _____

SPARK PLUGS OR FUEL INJECTORS MAKE: _____ PART #: _____

FUEL PUMP OR INJECTION PUMP MAKE: _____ MODEL: _____

ALTERNATOR MAKE: _____ PART #: _____

STARTER MAKE: _____ PART #: _____

TURBO CHARGER MAKE: _____ PART #: _____

TRANS. MAKE: _____ MODEL: _____ AUTO/MANUAL: _____

HYDRAULIC PUMP MAKE: _____ MODEL: _____

FILTERS	MAKE	PART NO.	LUBRICANT	MANUFACTURER TYPE
---------	------	----------	-----------	-------------------

OIL	_____	_____	ENGINE	_____
-----	-------	-------	--------	-------

AIR INNER	_____	_____	TRANSMISSION	_____
-----------	-------	-------	--------------	-------

AIR OUTER	_____	_____	POWER STEERING	_____
-----------	-------	-------	----------------	-------

FUEL PRIMARY	_____	_____	HYDRAULIC	_____
--------------	-------	-------	-----------	-------

FUEL SECONDARY	_____	_____	DIFFERENTIALS	_____
----------------	-------	-------	---------------	-------

COOLANT	_____	_____	BRAKE FLUID	_____
---------	-------	-------	-------------	-------

HYDRAULIC	_____	_____	COOLANT	_____
-----------	-------	-------	---------	-------

OTHER	_____	_____	OTHER	_____
-------	-------	-------	-------	-------

X6.3 TRAINING:

Will training seminar be conducted on Preventive Maintenance, Operator and Mechanic Training YES NO

Will you conduct training with each purchase order against this open end contract?
 YES NO

Will training be conducted within 2 working days from the delivery of the pilot unit on the individual purchase order? YES NO

If NO, explain time frame _____

Will an Operator's Manual be furnished directly to Training Academy prior to the delivery of the pilot? YES NO

X6.4 If you are the successful vendor, will you furnish all training aids, i.e., videos, projectors, required in conducting the training? YES NO

X6.4.1 Will all manuals, booklets, etc. explaining preventive maintenance, operator procedures, and service schedule be delivered with each unit?
 YES NO
If NO, explain _____

X6.5 WARRANTY AND SERVICE POLICY

Will the warranty and service you provide comply with all areas as stated in Section 6.5 of specifications YES NO

Is warranty literature attached? YES NO

Is a minimum two (2) year bumper to bumper basic parts and labor warranty excluding abuse and normal wear items included?
 YES NO

Describe:
_____ Two years bumper to bumper parts and labor _____

X6.6 EVALUATION COMMITTEE REQUIREMENTS

Is all component specifications, product literature, component models provided for Evaluation Committee bid determination? YES NO

X6.7 Will all parts, equipment, accessories, material, design and performance characteristics not specified herein, but which are necessary to provide a complete unit, be furnished with the unit and conform in strength, quality of material, and quality of workmanship to those which are advertised and provided to the market in general by the unit industry? YES NO

X6.7.1 Are all parts and accessories adequate and regularly supplied as standard to be included except those which may be duplications of specifications herein, and except these by specification are not to be furnished? YES NO

X6.7.2 Are all standard safety features that are required by Federal and State statutes of law included? YES NO

X7.0 SPECIFICATIONS OF THE QUOTED UNIT:

The bidder should complete the following schedule in order for the Division to compare the actual bid unit to the specifications. Should the bidder except a requirement, then such exception may be only on the basis that such feature is not offered by the manufacturer. The Division will have the sole discretion as to whether the bidder's substitution meets the requirements of the specification.

Manufacturer: Dressta **Model:** TD-7 Series R

X7.1 Engine:

X7.1.1 Is engine diesel YES NO

X7.1.2 Engine horsepower: 80

X7.1.3 Engine flywheel power: 74 HP

X7.2 Weight:

X7.2.1 Operating weight: 17,800 lbs. plus winch (1350 lbs.) = 19,150 lbs.

X7.3 Transmission:

X7.3.1 Travel speed forward: 5.56 MPH/ 8.95 KM/h

X7.3.2 Travel speed reverse: 6.55 MPH/ 10.54 KM/h

X7.4 Cab/ROPS/FOPS:

XD7.4.1 Does unit have fully enclosed cab with air conditioning, ROPS, FOPS, and rear screen x YES NO

X7.4.1.1 Does ROPS meet SAE J397-Oct. 95, SAFJ1040 May 94, ISO3471-94 ISO 3164-95 Standards x YES NO

X7.4.1.2 Does FOPS meet SAEJ231-Jan.81, ISO 3449 Standards x YES NO

X7.5 Winch:

X7.5.1 Is winch hydrostatic with variable control x YES NO

X7.5.2 Drum Capacity: feet SEE ADDENDUM

X7.5.2.1 Winch rope diameter 5/8 inches with tail chain and hook x YES NO
Does it comply with winch specifications x YES NO

X7.5.3 Minimum line pull (full drum): lbs./ kg SEE ADDENDUM

X7.5.4 Maximum line speed (full drum): feet/min m/min
SEE ADDENDUM

X7.5.5 Does winch meet or exceed all OSHA safety requirements x YES NO

X7.6 Undercarriage:

X7.6.1 Shoe width: 15 inches/ 381 mm

X7.6.2 Does unit have standard rock guards on each end x YES NO

X7.7 Blade:

X7.7.1 Does unit have a 6 way blade x YES NO

PREBID ADDENDUM #2
70-11-EC06

OPEN END CONTRACT
75 HORSEPOWER TRACTOR/DOZER WITH WINCH AND BLADE

CHANGES TO BIDDER'S EVALUATION REPORT:

NO CHANGE REQUIRED:

X4.2 DELIVERY:

X4.2.1 Delivery date of completed representative unit: 120 Calendar Days After
Receipt of Purchase Agreement

X4.2.2 Delivery date of balance of completed units: 180 Calendar Days After Receipt of
Purchase Agreement

FROM:

X7.5.2 Drum Capacity: feet

TO:

X7.5.2 Drum Capacity: 277 feet How many feet spooled: 150 feet

FROM:

X7.5.2.1 Winch rope diameter 5/8 inches with tail chain and hook YES NO
Does it comply with winch specifications YES NO

TO:

X7.5.2.1 Winch rope diameter 5/8 inch cable with tail chain and hook
 YES NO
Does it comply with winch specifications YES NO

FROM:

X7.5.3 Minimum line pull (full drum): lbs./ kg.

TO:

X7.5.3 Minimum line pull (full drum) 22050 lbs.

7011EC06
Bidder's Evaluation

FROM:

X7.5.4 Maximum line speed (full drum): _____ feet/min _____ m/min.

TO:

X7.5.4 Minimum line speed (full drum): 110 ft. per minute

DELETE: (Duplicate)

X7.11 Preventive Maintenance and Operators Orientation/Training:

X7.11.1 Will manufacturer or dealer conduct seminar at Buckhannon YES ___ NO

X7.11.2 Will you furnish all training aids YES ___ NO

State of West Virginia

VENDOR PREFERENCE CERTIFICATE

Certification and application* is hereby made for Preference in accordance with *West Virginia Code*, §5A-3-37. (Does not apply to construction contracts). *West Virginia Code*, §5A-3-37, provides an opportunity for qualifying vendors to request (at the time of bid) preference for their residency status. Such preference is an evaluation method only and will be applied only to the cost bid in accordance with the *West Virginia Code*. This certificate for application is to be used to request such preference. The Purchasing Division will make the determination of the Resident Vendor Preference, if applicable.

1. Application is made for 2.5% resident vendor preference for the reason checked:
 Bidder is an individual resident vendor and has resided continuously in West Virginia for four (4) years immediately preceding the date of this certification; or,
 Bidder is a partnership, association or corporation resident vendor and has maintained its headquarters or principal place of business continuously in West Virginia for four (4) years immediately preceding the date of this certification; or 80% of the ownership interest of Bidder is held by another individual, partnership, association or corporation resident vendor who has maintained its headquarters or principal place of business continuously in West Virginia for four (4) years immediately preceding the date of this certification; or,
 Bidder is a nonresident vendor which has an affiliate or subsidiary which employs a minimum of one hundred state residents and which has maintained its headquarters or principal place of business within West Virginia continuously for the four (4) years immediately preceding the date of this certification; or,
2. Application is made for 2.5% resident vendor preference for the reason checked:
 Bidder is a resident vendor who certifies that, during the life of the contract, on average at least 75% of the employees working on the project being bid are residents of West Virginia who have resided in the state continuously for the two years immediately preceding submission of this bid; or,
3. Application is made for 2.5% resident vendor preference for the reason checked:
 Bidder is a nonresident vendor employing a minimum of one hundred state residents or is a nonresident vendor with an affiliate or subsidiary which maintains its headquarters or principal place of business within West Virginia employing a minimum of one hundred state residents who certifies that, during the life of the contract, on average at least 75% of the employees or Bidder's affiliate's or subsidiary's employees are residents of West Virginia who have resided in the state continuously for the two years immediately preceding submission of this bid; or,
4. Application is made for 5% resident vendor preference for the reason checked:
 Bidder meets either the requirement of both subdivisions (1) and (2) or subdivision (1) and (3) as stated above; or,
5. Application is made for 3.5% resident vendor preference who is a veteran for the reason checked:
 Bidder is an individual resident vendor who is a veteran of the United States armed forces, the reserves or the National Guard and has resided in West Virginia continuously for the four years immediately preceding the date on which the bid is submitted; or,
6. Application is made for 3.5% resident vendor preference who is a veteran for the reason checked:
 Bidder is a resident vendor who is a veteran of the United States armed forces, the reserves or the National Guard, if, for purposes of producing or distributing the commodities or completing the project which is the subject of the vendor's bid and continuously over the entire term of the project, on average at least seventy-five percent of the vendor's employees are residents of West Virginia who have resided in the state continuously for the two immediately preceding years.

Bidder understands if the Secretary of Revenue determines that a Bidder receiving preference has failed to continue to meet the requirements for such preference, the Secretary may order the Director of Purchasing to: (a) reject the bid; or (b) assess a penalty against such Bidder in an amount not to exceed 5% of the bid amount and that such penalty will be paid to the contracting agency or deducted from any unpaid balance on the contract or purchase order.

By submission of this certificate, Bidder agrees to disclose any reasonably requested information to the Purchasing Division and authorizes the Department of Revenue to disclose to the Director of Purchasing appropriate information verifying that Bidder has paid the required business taxes, provided that such information does not contain the amounts of taxes paid nor any other information deemed by the Tax Commissioner to be confidential.

Under penalty of law for false swearing (*West Virginia Code*, §61-5-3), Bidder hereby certifies that this certificate is true and accurate in all respects; and that if a contract is issued to Bidder and if anything contained within this certificate changes during the term of the contract, Bidder will notify the Purchasing Division in writing immediately.

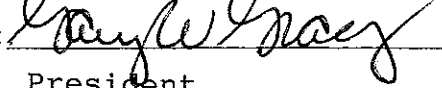
Bidder: West Virginia Tractor Company Signed: 
 Date: 11/23/10 Title: President

7011EC06

RFQ No. _____

STATE OF WEST VIRGINIA
Purchasing Division

PURCHASING AFFIDAVIT

West Virginia Code §5A-3-10a states: No contract or renewal of any contract may be awarded by the state or any of its political subdivisions to any vendor or prospective vendor when the vendor or prospective vendor or a related party to the vendor or prospective vendor is a debtor and the debt owned is an amount greater than one thousand dollars in the aggregate

DEFINITIONS:

"Debt" means any assessment, premium, penalty, fine, tax or other amount of money owed to the state or any of its political subdivisions because of a judgment, fine, permit violation, license assessment, defaulted workers' compensation premium, penalty or other assessment presently delinquent or due and required to be paid to the state or any of its political subdivisions, including any interest or additional penalties accrued thereon.

"Debtor" means any individual, corporation, partnership, association, Limited Liability Company or any other form or business association owing a debt to the state or any of its political subdivisions. "Political subdivision" means any county commission; municipality; county board of education; any instrumentality established by a county or municipality; any separate corporation or instrumentality established by one or more counties or municipalities, as permitted by law; or any public body charged by law with the performance of a government function or whose jurisdiction is coextensive with one or more counties or municipalities. "Related party" means a party, whether an individual, corporation, partnership, association, limited liability company or any other form or business association or other entity whatsoever, related to any vendor by blood, marriage, ownership or contract through which the party has a relationship of ownership or other interest with the vendor so that the party will actually or by effect receive or control a portion of the benefit, profit or other consideration from performance of a vendor contract with the party receiving an amount that meets or exceeds five percent of the total contract amount.

EXCEPTION: The prohibition of this section does not apply where a vendor has contested any tax administered pursuant to chapter eleven of this code, workers' compensation premium, permit fee or environmental fee or assessment and the matter has not become final or where the vendor has entered into a payment plan or agreement and the vendor is not in default of any of the provisions of such plan or agreement.

Under penalty of law for false swearing (*West Virginia Code* §61-5-3), it is hereby certified that the vendor affirms and acknowledges the information in this affidavit and is in compliance with the requirements as stated.

WITNESS THE FOLLOWING SIGNATURE

Vendor's Name: West Virginia Tractor Company

Authorized Signature: *Gayle W. Gray* Date: 11/23/10

State of West Virginia

County of Kanawha, to-wit:

Taken, subscribed, and sworn to before me this 23 day of ~~December~~ November, 2010

My Commission expires August 12, 2012

AFFIX SEAL HERE

NOTARY PUBLIC *Steven B. Basham*

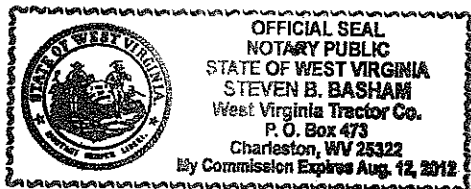

WEST VIRGINIA TRACTOR COMPANY

7011EC06 Exceptions to Specifications

- 7.3.1 Our forward speed is 5.56 MPH instead of 5.6 MPH.
- 7.3.2 Our reverse speed is 6.55 MPH instead of 6.0 MPH.
- 7.6.1 Our shoe width is 15" instead of 16".



SERVICE POLICY & PROCEDURE MANUAL

Warranty Policy

SUBJECT: STANDARD WARRANTY COVERAGE AND CONDITIONS

A. GENERAL PROVISIONS

The Company warrants to the Distributor all products (except items not covered listed in section C & E) sold under this Agreement to be free from defects in material and workmanship for the respective periods specified in paragraph B below, subject to the other terms specified hereafter.

B. BASIC WARRANTY

The warranty period for the machines, engines and parts shall terminate upon the expiration of one of the following periods:

1. For machines, unless specified in separate sales contracts, upon the expiration of a period of twelve **(12) months** after the date of delivery of the machine to the Customer, what is to be confirmed by Delivery Service Report, or a period of 24 months after the date of shipment of the machine from the Company to distributor whichever expires first.
2. For all replacement parts furnished pursuant to this warranty, upon the expiration of the remainder of the warranty period applicable to the machine in which such parts were installed.

C. CUMMINS ENGINE WARRANTY

This Basic Warranty does not apply to Cummins engines, whether or not such engines are installed in products or sold separately.

All Cummins engines are warranted by Cummins for a period of one year from the date of original delivery and their warranty is administered by local authorized Cummins Dealers.

D. ZF Warranty

Warranty Terms and Service Procedures for ZF Passau Transmissions WG210 and Axles MTL 3085, 3095, MT 3105, applied in Dressta Loaders.

1. Standard Warranty for ZF transmissions and axles in Dressta Loaders is identical as machine basic warranty, i.e. 12 months, following the date of machine delivery to the Customer.
2. ZF Extended Warranty.
Dressta and ZF offer Extended Warranty for 36 months or 5000 hours from D/D



TD-7R

CRAWLER DOZER
STD-LT-LGP

■ **Net Horsepower**
74 hp (55 kW)

■ **Blade Capacity**
1.81 yd³ (1.40 m³)
1.90 yd³ (1.45 m³)

■ **Operating Weight**
16,942 lb (7685 kg) STD
17,712 lb (8034 kg) LT
18,373 lb (8334 kg) LGP



TD-7R

CRAWLER DOZER

STD-LT-LGP

- Full power shift transmission
- Highly efficient torque converter
- Wet-type steering clutches and brakes
- Hydraulic lift, tilt & angle blade
- Left joystick for transmission and steering control

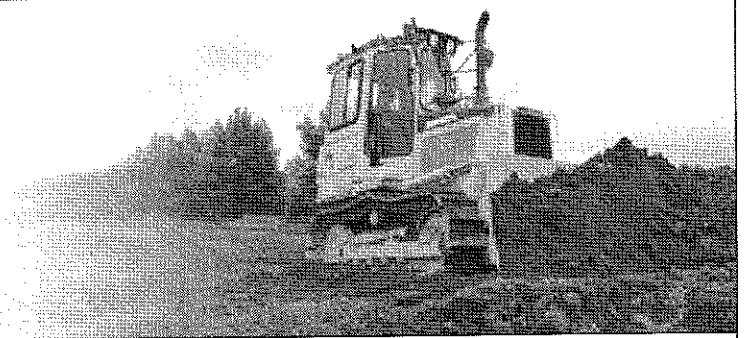

ENGINE

* Make and Model	CUMMINS QSB3.3
Type	In-line, 4-cylinder
Aspiration	Turbocharged and CAC
Fuel system	Electronic
Gross Horsepower, SAE J 1995	80 hp (60 kW)
Net Horsepower, SAE J 1349/ISO 9249	74 hp (55 kW)
Rated rpm	2200 rpm
Max. torque @1400 rpm	274 ft-lb (371 Nm)
Displacement	199 in ³ (3.3 l)
Bore and Stroke	3.74" x 4.53" (95 x 115 mm)
Air cleaner	two stage, dry type with service indicator

*Meets EU Stage IIIA and EPA Tier 3 emission regulations

TRANSMISSION & TORQUE CONVERTER

Modular countershaft type full power shift, electro-hydraulically actuated with 3 speeds forward, 3 reverse. Joystick control valve has electric transmission range shift control for up and down shifting. Single stage 11" (280 mm) torque converter with 1.986:1 stall ratio drives to transmission through a permanently lubricated double universal joint.

TRAVEL SPEEDS

Gear	Forward		Reverse	
	mph	(km/h)	mph	(km/h)
1 st	2.05	3.30	2.44	(3.93)
2 nd	3.39	5.46	4.02	(6.47)
3 rd	5.56	8.95	6.55	(10.54)

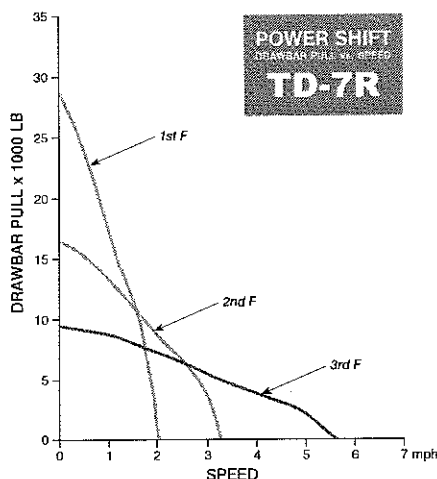

STEERING & BRAKING

Single stage planetary type, wet single disc steering clutches. Single disc, wet-type steering brakes. Steering clutches and brakes run in oil and are hydraulically actuated. Right foot pedal applies decelerator, center pedal applies disc brakes for downhill speed control and parking. Brakes are spring applied and hydraulically released. Parking brake is also applied by safety lever.

FINAL DRIVES

Single stage spur-gear drive to sprockets 5.08:1 reduction ratio. Final drive has metal face seals. Operates in oil for long life. Sprockets are replaceable without removing track frames.

TRACK FRAME

Heavy steel channel, rigid mount.

	STD	LT	LGP
Track rollers each side	5	6	6
Top idlers each side	1		
Front idlers (disc type)	casting		
All rollers and idlers	lifespan lubricated		

TRACKS

	STD	LT	LGP
Track shoe width	15" (381 mm)	15" (381 mm)	24" (610 mm)
Track shoes, each side	34	37	37
Ground contact area	2,160 in ² (1.4 m ²)	2,460 in ² (1.59 m ²)	3,936 in ² (2.54 m ²)
Ground pressure	7.84 psi (54 kPa)	7.20 psi (49.6 kPa)	4.67 psi (32.2 kPa)
Strutted track link pitch	6.5" (165 mm)		
Height of grouser	2.11" (53.6 mm)		
Track adjustment	full hydraulic		
Minimum ground clearance from bottom face of shoe	12.7" (323 mm)		
Recovery hitch-height from ground to centerline of clevis	18.8" (477 mm)		

REFILL CAPACITIES

	US gal	(Liter)
Fuel tank	45	(170)
Cooling system	4.0	(15.2)
Crankcase	1.8	(7.0)
Transmission & steering drive	17.2	(65)
Final drive, each side	2.5	(9.5)

OPERATING WEIGHT

Includes ROPS, hydraulic angle blade, standard equipment and full fuel.	
STD	16,942 lb (7685 kg)
LT	17,712 lb (8034 kg)
LGP	18,373 lb (8334 kg)

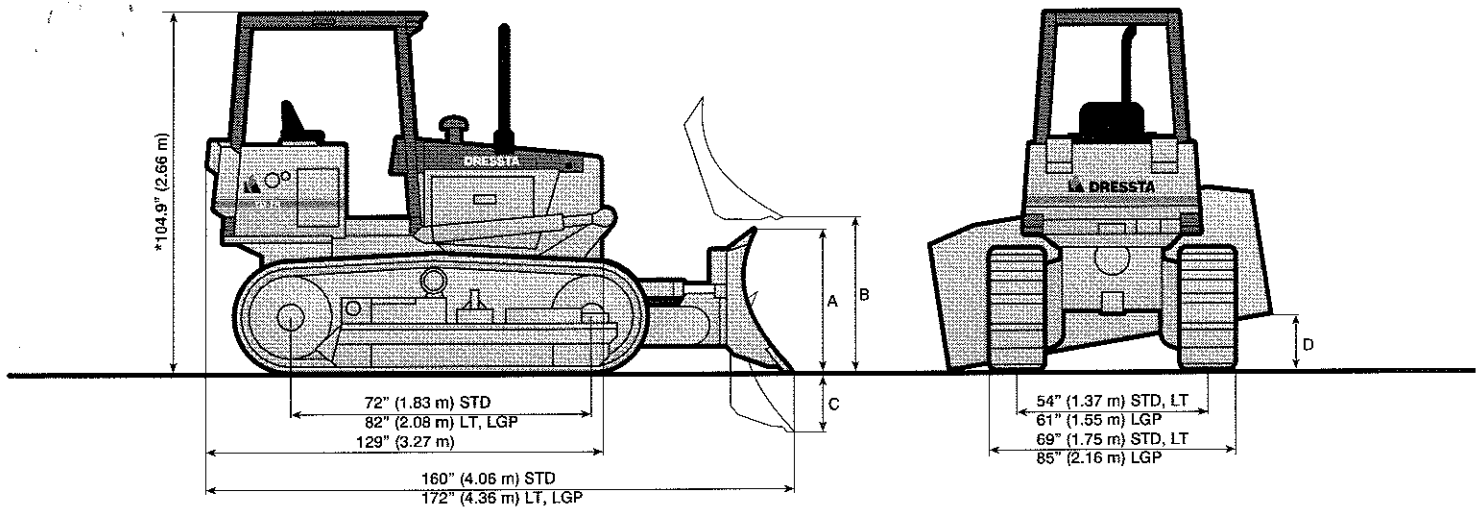

* Dimension includes 2.11" (53.6 mm) grouser height
 Overall height with Cab ROPS – 106.2" (2.70 m)

OVERALL DIMENSIONS WITH EQUIPMENT

Type of Track Frame	STD	LT	LGP
Length, with blade and drawbar	14'9" (4.50 m)	15'8" (4.78 m)	15'8" (4.78 m)
Width, blade angled	7'10" (2.39 m)	7'10" (2.39 m)	8'5" (2.57 m)
Width, blade straight	8'7" (2.62 m)	8'7" (2.62 m)	9'3" (2.82 m)

BLADE SPECIFICATIONS

Type of Track Frame	STD	LT	LGP
Blade capacity, SAE J1265	1.81 yd ³ (1.4 m ³)	1.81 yd ³ (1.4 m ³)	1.90 yd ³ (1.45 m ³)
Max. usable track shoe width	17" (432 mm)	17" (432 mm)	24" (610 mm)
Blade dimensions:			
– width over end bits	8'7" (2.62 m)	8'7" (2.62 m)	9'3" (2.82 m)
– height, struts centered A	2'9" (0.84 m)	2'9" (0.84 m)	2'9" (0.84 m)
Max. lift, straight B	37" (0.94 m)	35" (0.89 m)	35" (0.89 m)
Max. drop below ground level C	17.7" (0.45 m)	17.3" (0.44 m)	17.3" (0.44 m)
Max. tilt adjustment D	15.2" (0.39 m)	15.2" (0.39 m)	16.4" (0.42 m)
Blade angle, either side	25°	25°	25°

RIPPER SPECIFICATION

Type	Multi-Shank
Tool Beam	Shanks
Overall width	47" (1.40 m)
Cross section, height x width	6.0" x 6.0" (152 x 152 mm)
Ground clearance under tool beam	27.4" (696 mm)
Weight	Number of shanks per ripper, max. 5
Complete, including three shanks	950 lb (430 kg)
Each additional shank	20 lb (9 kg)
	Spacing center to center
	13" (330 mm)
	Penetration, max.
	11" (279 mm)
	Ground clearance, max. raised
	15.5" (394 mm)
	Shank positions (vertical)
	2

HYDRAULIC CONTROL SYSTEM

Pump, tandem gear	Cylinders, bore and stroke
Output @ 500 psi (3.45 MPa)	Lift (2)
& rated engine rpm	3.5" x 17.7" (89 x 449 mm)
19.9 gpm (75.2 l/min)	Angle (2)
Relief valve setting	3.0" x 13.9" (76 x 352 mm)
Blade lift & ripper	Tilt (1)
2,250 psi (15 512 kPa)	3.5" x 5.7" (89 x 144 mm)
Tilt	Reservoir with sight gauge, system capacity, right fender mounted,
2,250 psi (15 512 kPa)	includes cylinders & lines
	13.5 gal (51 l)

TD-7R

CRAWLER DOZER

STD-LT-LGP



STANDARD EQUIPMENT

- | | |
|--|--|
| <ul style="list-style-type: none"> • Air cleaner, dry type, with primary and safety elements and service indicator • Alarm, back-up • Alternator, 105 A • Antifreeze, -34°F (-37°C) • Battery, (1) 12 V, 815 CCA, maintenance free • Canopy ROPS (SAE J1040) with roof extension, roof headliner, mirror • Cooling module; includes radiator, transmission oil cooler and charge air cooler; isolation mounted • Cup holder • Decelerator – right pedal and brake – left pedal with safety lock, foot operated • Engine hood, solid • Engine side doors, perforated • Fan, blower • Filters, with "spin-on" elements, engine oil, fuel, power train, equipment hydraulic • Guards: crankcase with pull hook, instrument panel, lights, radiator, transmission, rock deflector, fan, fuel tank bottom and back-up alarm • Hitch, retrieval • Horn • Hydraulics, 3-spool valve, "T" control • Instruments:
Gauges: fuel level, coolant temperature, engine oil pressure, power train oil temperature, voltmeter, hourmeter | <ul style="list-style-type: none"> Warning lights: transmission filter service indicator, air filter and hydraulic filter service indicator • Lights, 2 front, 1 rear, halogen type • Muffler, underhood with exhaust pipe and elbow • Power train diagnostic check panel w/brake release port • Protection guard for fuel tank and filler • Radiator guard door, louvered • Seat belt (SAE J386) – 3" wide, retractable • Seat, suspension type with adjustable arm rests • Starting aid – air grid heater • Starting, 12 V • Steering & transmission, left hand single lever control, joystick w/safety lever • Strainer, fuel • Throttle control, L.H. location • Tools compartment • Torque converter, single stage • Track adjusters, hydraulic • Track chains, sealed & lubricated (LTS) with split master links, 37 links • Track frame, 5 rollers, 54" (1.37 m) gauge, rigid type, lifespan lubricated rollers and idlers, front and rear chain guides • Track frame covers • Track shoes, 15" (381 mm) • Transmission, full power shift, 3 speeds forward, 3 reverse • Water separator, fuel system |
|--|--|

OPTIONAL ATTACHMENTS

- | | |
|--|--|
| <ul style="list-style-type: none"> • Air conditioner/heater/pressurizer/defroster • Angle dozer 1.81 cu.yd (1.40 cu.m), inside arm w/hyd. tilt & angle, for STD • Angle dozer 1.81 cu.yd (1.40 cu.m), inside arm w/hyd. tilt & angle, for LT • Angle dozer, wide, 1.90 cu.yd (1.45 cu.m), inside arm w/hyd. tilt & angle, for LGP • Battery, cold start, 12 V, 960 CCA • Counterweights, front idler • Cab, ROPS with sound suppression, wipers (4) and washers, mirror, dome light & tinted safety glass • Defroster fan (for use w/cab) • Exhaust pipe, forestry (for use w/sweeps) • Fan, reversible • Guards <ul style="list-style-type: none"> – track roller, standard strength – track roller, full length, heavy duty type • Heater/pressurizer/defroster • Hood, perforated (blower fan recommended) • Hydraulics, 4-spool valve, 2 levers ("T" + single), for use w/ripper or auxiliary attachments • Limb risers, straight (not for use w/cab) • Lubricated track system, 37 links, for LT and LGP • Mirrors, 2 pcs, (for use w/cab) • Resonator, exhaust • Ripper, multi-shank w/3 teeth (provision for 5 teeth) | <ul style="list-style-type: none"> • Screening package, black painted (Canopy ROPS for screens installation must be ordered) <ul style="list-style-type: none"> – screens, front – screen, rear – doors and side screens w/third post – screen, overhead, for upper front lights protection • Sealed track system, 34 links, for STD • Sweeps, front (not for use w/cab) • Track frame for LT applications, 6 rollers, 54" (1.37 m) gauge, rigid type • Track frame for LGP applications, 6 rollers, 61" (1.55 m) gauge, rigid type • Track frame covers, LT • Track frame covers, LGP • Track shoes, set of 68, for STD <ul style="list-style-type: none"> – 15" (381 mm) w/mud relief – 17" (432 mm) • Track shoes, set of 74, for LT <ul style="list-style-type: none"> – 15" (381 mm) – 15" (381 mm) w/mud relief – 17" (432 mm) • Track shoes, set of 74, for LGP <ul style="list-style-type: none"> – 24" (610 mm) • Vandalism protection |
|--|--|

Specifications subject to change without notice. Illustrations may include optional attachments and accessories and may not include all standard equipment.
NOTE: Low Ground Pressure (LGP) tractors are designed for use in mud, snow and other soft ground applications.
Use in hard or rocky conditions will reduce undercarriage life and can cause damage to components.

DRESSTA NORTH AMERICA, LTD.

1327 BARCLAY BLVD.
BUFFALO GROVE, IL 60089
phone (847) 537 4783 fax (847) 537 2873
Toll free (877) DNA 2001
www.dresstanorthamerica.com

H4A Hydraulic Winch



Description

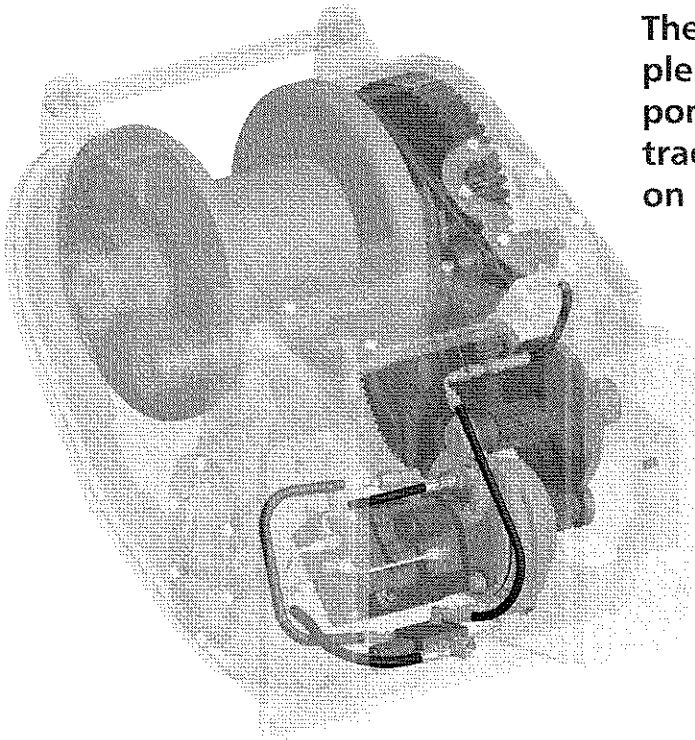

The H4A, an all-new hydraulic winch for simple field installation. Complete with all components to install on any 70-100 Hp track-type tractor. No need for "winch ready" package on tractor.

- Excels at precision control
- Two-speed motor
- One low-effort lever controls all functions: Brake-On, Power-In, Power-Out and Freespool

Features

- Motor turns only on demand—less wear and tear, quiet operation
- Single lever, finger-tip control
- Large cable capacity drum with increased throat clearance
- Welded steel frame with bolt-on attachments and for easy installation
- Two gear ratios available
- Large covers for easy service access

Options

- Four-roller fairlead, bolt-on
- Arch, bolt-on; two-way adjustable (back tilt and roller height)
- Drawbar, bolt-on
- Slow gear ratio
- H4AH High Performance (Hi-P) winch for frequent high speed, high line pull production work, such as logging
- Lower-cost H4AT Rescue winch for slow speed, high line pull equipment rescue applications

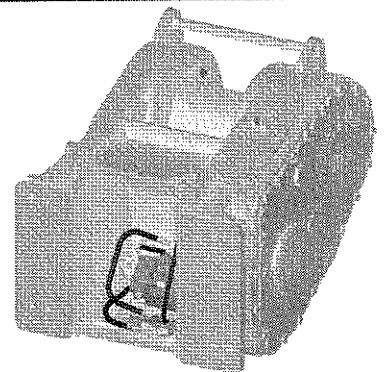

H4A Hydraulic Winch



Performance

Winch Model (Type)			H4AH (Hi-P)		H4AH (Hi-P)		H4AT (Rescue)		H4AT (Rescue)	
Winch Gear Ratio			94:1		116:1		116:1*		125:1*	
Winch Drive Motor Speed			HI	LO	HI	LO	HI	LO	HI	LO
Layer	Situation	Units								
Bare Drum	Max. Pull	Lbs.	18,150	38,600	22,350	47,500	17,000	39,700	3,300	32,150
		(Kg)	(8,233)	(17,509)	(10,138)	(21,546)	(7,711)	(18,008)	(1,497)	(14,583)
	Max. Speed	fpm	105	63	85	51	48	28	46	28
		(mpm)	(32.0)	(19.2)	(25.9)	(15.5)	(14.6)	(8.5)	(14.0)	(8.5)
Full Drum	Max. Pull	Lbs.	10,350	22,050	12,750	27,150	9,700	22,700	1,850	18,350
		(Kg)	(4,695)	(10,002)	(5,783)	(12,315)	(4,400)	(10,297)	(839)	(8,323)
	Max. Speed	fpm	184	110	149	89	84	50	81	48
		(mpm)	(56.1)	(33.5)	(45.4)	(27.1)	(25.6)	(15.2)	(24.7)	(14.6)

* Ratio 116:1 used on tractors with more than 3,300 psi, ratio 124:1 on tractors with less than 3,300 psi.

Dimensional Data

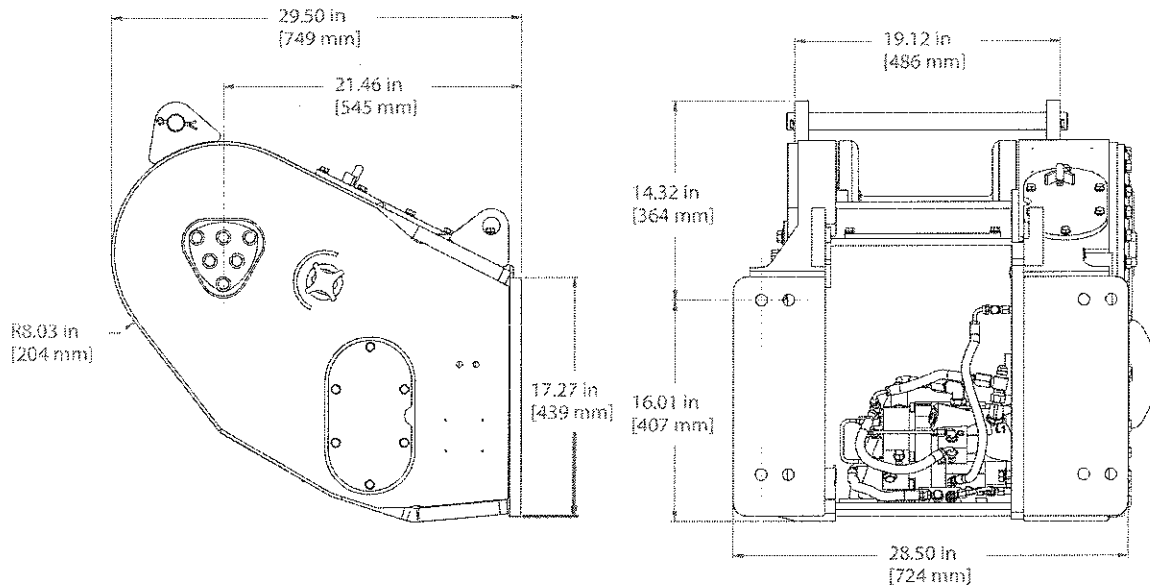

Specifications

Drum Size

Barrel Diameter8.00 in. (203mm)
 Barrel Length.....9.50 in. (241mm)
 Flange Diameter 16.00 in. (406mm)

Drum Capacity

5/8-inch (16mm) cable 277 ft. (84.4m)
 3/4-inch (19mm) cable 195 ft. (59.4m)

Weight

1,350 lbs. (612 kg), including pump, hoses, filter and control.

Ferrule Size

Type	Length	Diameter
B5	2 in. (51mm)	1.5 in. (38mm)
B6	2 in. (51mm)	1.5 in. (38mm)



21433 SW Oregon Street
 Sherwood, OR 97140 USA
 phone: 503.625.2560
 fax: 503.625.7269
 www.alliedsystems.com
 marketing@alliedsystems.com

DISTRIBUTED BY:



CONFIDENTIAL, FOR INTERNAL USE OF DRESSTA NORTH AMERICA LTD. AND ITS DISTRIBUTORS

Dressta History

The legacy of Dressta Dozers is rooted in the early years of the International Harvester Construction Equipment business. Our earliest Crawlers date from the late 1920's.



INTERNATIONAL CRAWLERS

Excavate for *Houses by the Block*

HOME BUILDERS know their business. They are experts in the use of modern methods and equipment to speed their work.

When they get the materials and tools they need, their unequalled skill, ingenuity and resourcefulness will quickly provide the housing facilities the people require.

Prezo! Houses in the modern manner!

Yes, hats off to the Builders of the Nation... and to the operators of INTERNATIONAL DOZER CRAWLERS who prepare the way. It's a winning combination... a winning team that will soon have houses built... houses by the block!

Good Evening - "Harvest of Iron"
 from *Harvest of Iron - America's Original Team*
 H&M, Newark

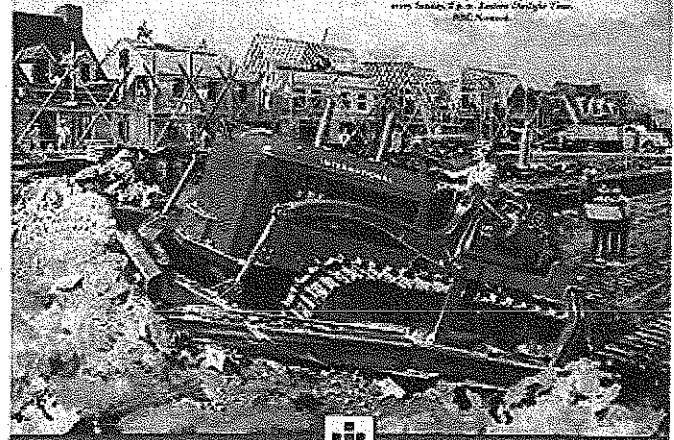

INTERNATIONAL Industrial Power

Now Appearing In
 SATURDAY EVENING POST—COLLIER'S WEEKLY—TIME—NEWSWEEK

The Plant

H&W - Stalowa Wola

Sales All Over The World

Brief Timeline

We have been in business since the 1920s as International Harvester, Dresser, Komatsu-Dresser, Komatsu and Dressta.

- 2007 Bolingbrook, Illinois Parts Depot opened to better serve Dressta customers
- 2005 HSW purchased the Komatsu portion of the joint venture. Komatsu and Dressta parts were serviced from the Komatsu parts facility in Ripley Tennessee.
- 2001 Komatsu and HSW agreed to separate Dressta and Komatsu sales divisions but continued to service all parts from the Komatsu facility in Ripley Tennessee
- 1998 Due to the acquisition of Dressta by Halliburton Corp. the Dresser brand changed to Dressta which was used in other parts of the world.
- 1985 Komatsu purchased the remaining Dresser interest in KDC. Machines were sold as Komatsu and Dresser branded products. Poland's HSW continued to build Dresser and some Komatsu machines
- 1983 Komatsu of Japan bought 40% of Dresser's Construction Equipment business. Machines were sold as Komatsu and Dresser brands
- 1980 International Harvester sold the construction equipment division to Dresser Industries of Dallas Texas. The machines were then branded as Dresser machines

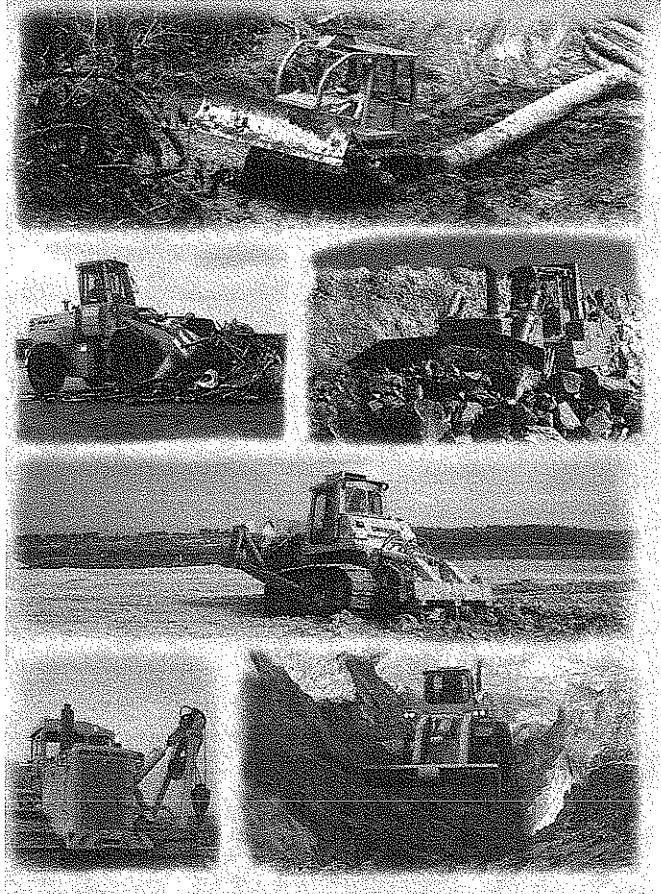

In the mid 1960's International Harvester began to ship components to HSW in Poland for assembly of dozers and likewise shipped components to Komatsu in Japan for assembly of loaders. Manufacturing continued at Libertyville and Melrose Park Illinois as well as other facilities around the world.