



State of West Virginia
 Department of Administration
 Purchasing Division
 2019 Washington Street East
 Post Office Box 50130
 Charleston, WV 25305-0130

Request for Quotation

RFQ NUMBER
 07110156

PAGE
 1

ADDRESS CORRESPONDENCE TO ATTENTION OF
 BUYER 33
 304-558-2402

RFQ COPY
 TYPE NAME/ADDRESS HERE

JAMATT INC.
 Route 1, 351 Cleman's Road
 Flemington, WV 26347

DIVISION OF HIGHWAYS
 DISTRICT SEVEN
 STORAGE YARD
 1205 US HWY 19 SOUTH
 WESTON, WV
 26452 304-269-0475

DATE PRINTED	TERMS OF SALE	SHIP VIA	FOB	FREIGHT TERMS
12/22/2010				

BID OPENING DATE: 01/26/2011 BID OPENING TIME 01:30PM

LINE	QUANTITY	UOP	CAT NO	ITEM NUMBER	UNIT PRICE	AMOUNT
0001	1	LB		570-84	\$19,220.70	\$19,220.70
TO PROVIDE STRUCTURAL STEEL FOR BEAR FORK W BEAM						
REQUEST FOR QUOTATION (RFQ)						
THE WEST VIRGINIA STATE PURCHASING DIVISION FOR THE AGENCY, THE WEST VIRGINIA DIVISION OF HIGHWAYS, IS SOLICITING BIDS FOR A CONTRACT TO PROVIDE STRUCTURAL STEEL FOR BEAR FORK W BEAM BRIDGE, PROJECT NO S311-8-5:23, PER THE ATTACHED SPECIFICATIONS.						
ALL MATERIAL ARE TO BE SHIPPED TO DISTRICT 7 STORAGE YARD, 1205 US HWY 19 SOUTH WESTON, WV 26452						
TECHNICAL QUESTIONS CONCERNING THIS SOLICITATION MUST BE SUBMITTED IN WRITING TO SHERI SLONE IN THE WEST VIRGINIA STATE PURCHASING DIVISION VIA MAIL AT THE ADDRESS SHOWN IN THE BODY OF THIS RFQ, VIA FAX AT 304-558-2596, OR VIA EMAIL AT SHERI.D.SLONE@WV.GOV. DEADLINE FOR TECHNICAL QUESTIONS IS 01/17/2011 AT THE CLOSE OF BUSINESS. ANY TECHNICAL QUESTIONS RECEIVED WILL BE ANSWERED BY FORMAL ADDENDUM TO BE ISSUED BY THE PURCHASING DIVISION AFTER THE DEADLINE HAS LAPSED.						
EXHIBIT 10						
REQUISITION NO.: 07110156...						

RECEIVED
 2011 FEB -1 A 10:16
 PURCHASING DIVISION
 STATE OF WV

SEE REVERSE SIDE FOR TERMS AND CONDITIONS			
SIGNATURE <i>James P. McHugh</i>	TELEPHONE 304-842-0367	DATE 01/29/2011	
TITLE PRESIDENT	FEIN 20-1894398	ADDRESS CHANGES TO BE NOTED ABOVE	

WHEN RESPONDING TO RFQ, INSERT NAME AND ADDRESS IN SPACE ABOVE LABELED 'VENDOR'

GENERAL TERMS & CONDITIONS REQUEST FOR QUOTATION (RFQ) AND REQUEST FOR PROPOSAL (RFP)

1. Awards will be made in the best interest of the State of West Virginia.
2. The State may accept or reject in part, or in whole, any bid.
3. Prior to any award, the apparent successful vendor must be properly registered with the Purchasing Division and have paid the required \$125 fee.
4. All services performed or goods delivered under State Purchase Order/Contracts are to be continued for the term of the Purchase Order/Contracts, contingent upon funds being appropriated by the Legislature or otherwise being made available. In the event funds are not appropriated or otherwise available for these services or goods this Purchase Order/Contract becomes void and of no effect after June 30.
5. Payment may only be made after the delivery and acceptance of goods or services.
6. Interest may be paid for late payment in accordance with the *West Virginia Code*.
7. Vendor preference will be granted upon written request in accordance with the *West Virginia Code*.
8. The State of West Virginia is exempt from federal and state taxes and will not pay or reimburse such taxes.
9. The Director of Purchasing may cancel any Purchase Order/Contract upon 30 days written notice to the seller.
10. The laws of the State of West Virginia and the *Legislative Rules* of the Purchasing Division shall govern the purchasing process.
11. Any reference to automatic renewal is hereby deleted. The Contract may be renewed only upon mutual written agreement of the parties.
12. **BANKRUPTCY:** In the event the vendor/contractor files for bankruptcy protection, the State may deem this contract null and void, and terminate such contract without further order.
13. **HIPAA BUSINESS ASSOCIATE ADDENDUM:** The West Virginia State Government HIPAA Business Associate Addendum (BAA), approved by the Attorney General, is available online at www.state.wv.us/admin/purchase/vrc/hipaa.htm and is hereby made part of the agreement. Provided that the Agency meets the definition of a Cover Entity (45 CFR §160.103) and will be disclosing Protected Health Information (45 CFR §160.103) to the vendor.
14. **CONFIDENTIALITY:** The vendor agrees that he or she will not disclose to anyone, directly or indirectly, any such personally identifiable information or other confidential information gained from the agency, unless the individual who is the subject of the information consents to the disclosure in writing or the disclosure is made pursuant to the agency's policies, procedures, and rules. Vendor further agrees to comply with the Confidentiality Policies and Information Security Accountability Requirements, set forth in <http://www.state.wv.us/admin/purchase/privacy/noticeConfidentiality.pdf>.
15. **LICENSING:** Vendors must be licensed and in good standing in accordance with any and all state and local laws and requirements by any state or local agency of West Virginia, including, but not limited to, the West Virginia Secretary of State's Office, the West Virginia Tax Department, and the West Virginia Insurance Commission. The vendor must provide all necessary releases to obtain information to enable the director or spending unit to verify that the vendor is licensed and in good standing with the above entities.
16. **ANTITRUST:** In submitting a bid to any agency for the State of West Virginia, the bidder offers and agrees that if the bid is accepted the bidder will convey, sell, assign or transfer to the State of West Virginia all rights, title and interest in and to all causes of action it may now or hereafter acquire under the antitrust laws of the United States and the State of West Virginia for price fixing and/or unreasonable restraints of trade relating to the particular commodities or services purchased or acquired by the State of West Virginia. Such assignment shall be made and become effective at the time the purchasing agency tenders the initial payment to the bidder.

I certify that this bid is made without prior understanding, agreement, or connection with any corporation, firm, limited liability company, partnership, or person or entity submitting a bid for the same material, supplies, equipment or services and is in all respects fair and without collusion or Fraud. I further certify that I am authorized to sign the certification on behalf of the bidder or this bid.

INSTRUCTIONS TO BIDDERS

1. Use the quotation forms provided by the Purchasing Division. Complete all sections of the quotation form.
2. Items offered must be in compliance with the specifications. Any deviation from the specifications must be clearly indicated by the bidder. Alternates offered by the bidder as **EQUAL** to the specifications must be clearly defined. A bidder offering an alternate should attach complete specifications and literature to the bid. The Purchasing Division may waive minor deviations to specifications.
3. Unit prices shall prevail in case of discrepancy. All quotations are considered F.O.B. destination unless alternate shipping terms are clearly identified in the quotation.
4. All quotations must be delivered by the bidder to the office listed below prior to the date and time of the bid opening. Failure of the bidder to deliver the quotations on time will result in bid disqualifications: Department of Administration, Purchasing Division, 2019 Washington Street East, P.O. Box 50130, Charleston, WV 25305-0130
5. Communication during the solicitation, bid, evaluation or award periods, except through the Purchasing Division, is strictly prohibited (W.Va. C.S.R. §148-1-6.6).



State of West Virginia
 Department of Administration
 Purchasing Division
 2019 Washington Street East
 Post Office Box 50130
 Charleston, WV 25305-0130

Request for Quotation

RFQ NUMBER
 07110156

PAGE
 2

ADDRESS CORRESPONDENCE TO ATTENTION OF
 BUYER 33
 304-558-2402

RFQ COPY
 TYPE NAME/ADDRESS HERE

SHIP TO

JAMATT INC.
 Route 1, 351 Cleman's Road
 Flemington, WV 26347

SHIP TO

DIVISION OF HIGHWAYS
 DISTRICT SEVEN
 STORAGE YARD
 1205 US HWY 19 SOUTH
 WESTON, WV
 26452 304-269-0475

DATE PRINTED	TERMS OF SALE	SHIP VIA	FOB	FREIGHT TERMS
12/22/2010				

BID OPENING DATE: 01/26/2011 BID OPENING TIME 01:30PM

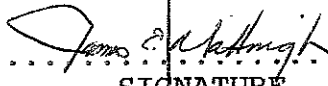
LINE	QUANTITY	UOP	CAT. NO.	ITEM NUMBER	UNIT PRICE	AMOUNT
<p>ADDENDUM ACKNOWLEDGEMENT</p> <p>I HEREBY ACKNOWLEDGE RECEIPT OF THE FOLLOWING CHECKED ADDENDUM(S) AND HAVE MADE THE NECESSARY REVISIONS TO MY PROPOSAL, PLANS AND/OR SPECIFICATION, ETC.</p> <p>ADDENDUM NO.'S:</p> <p>NO. 1 ✓</p> <p>NO. 2</p> <p>NO. 3</p> <p>NO. 4</p> <p>NO. 5</p> <p>I UNDERSTAND THAT FAILURE TO CONFIRM THE RECEIPT OF THE ADDENDUM(S) MAY BE CAUSE FOR REJECTION OF BIDS.</p> <p>VENDOR MUST CLEARLY UNDERSTAND THAT ANY VERBAL REPRESENTATION MADE OR ASSUMED TO BE MADE DURING ANY ORAL DISCUSSION HELD BETWEEN VENDOR'S REPRESENTATIVES AND ANY STATE PERSONNEL IS NOT BINDING. ONLY THE INFORMATION ISSUED IN WRITING AND ADDED TO THE SPECIFICATIONS BY AN OFFICIAL ADDENDUM IS BINDING.</p> <p style="text-align: right;">  SIGNATURE JAMATT, INC. COMPANY </p>						

SEE REVERSE SIDE FOR TERMS AND CONDITIONS

SIGNATURE	TELEPHONE	DATE
TITLE	FEIN	ADDRESS CHANGES TO BE NOTED ABOVE

WHEN RESPONDING TO RFQ, INSERT NAME AND ADDRESS IN SPACE ABOVE LABELED 'VENDOR'



State of West Virginia
 Department of Administration
 Purchasing Division
 2019 Washington Street East
 Post Office Box 50130
 Charleston, WV 25305-0130

Request for Quotation

RFQ NUMBER
 07110156

PAGE
 3

ADDRESS CORRESPONDENCE TO ATTENTION OF
 BUYER 33
 304-558-2402

RFQ COPY
 TYPE NAME/ADDRESS HERE

JAMATT INC.
 Route 1, 351 Cleman's Road
 Flemington, WV 26347

DIVISION OF HIGHWAYS
 DISTRICT SEVEN
 STORAGE YARD
 1205 US HWY 19 SOUTH
 WESTON, WV
 26452 304-269-0475

DATE PRINTED	TERMS OF SALE	SHIP VIA	FOB	FREIGHT TERMS
12/22/2010				

BID OPENING DATE: 01/26/2011 BID OPENING TIME 01:30PM

LINE	QUANTITY	UOP	CAT NO	ITEM NUMBER	UNIT PRICE	AMOUNT
<p>..... 01/29/2011</p> <p>DATE</p>						
<p>NOTE: THIS ADDENDUM ACKNOWLEDGEMENT SHOULD BE SUBMITTED WITH THE BID.</p> <p>REV. 09/21/2009</p> <p>BANKRUPTCY: IN THE EVENT THE VENDOR/CONTRACTOR FILES FOR BANKRUPTCY PROTECTION, THE STATE MAY DEEM THE CONTRACT NULL AND VOID, AND TERMINATE SUCH CONTRACT WITHOUT FURTHER ORDER.</p> <p>PREFERENCE FOR USE OF DOMESTIC STEEL PRODUCTS</p> <p>1. EXCEPT WHEN AUTHORIZED BY THE DIRECTOR OF THE PURCHASING DIVISION PURSUANT TO SUBSECTION 2 BELOW, NO CONTRACTOR MAY USE OR SUPPLY STEEL PRODUCTS FOR A STATE CONTRACT PROJECT OTHER THAN THOSE STEEL PRODUCTS MADE IN THE UNITED STATES. AS USED USED IN THIS CONTRACT,</p> <p>A. "STATE CONTRACT PROJECT" MEANS ANY ERECTION OR CONSTRUCTION OF, OR ANY ADDITION TO, ALTERATION OF OR OTHER IMPROVEMENT TO ANY BUILDING OR STRUCTURE, INCLUDING, BUT NOT LIMITED TO, ROADS OR HIGHWAYS, OR THE INSTALLATION OF ANY HEATIN OR COOLING OR VENTILATING PLANTS OR OTHER EQUIPMENT, OR THE SUPPLY OF AND MATERIALS FOR SUCH PROJECTS, PURSUANT TO A CONTRACT WITH THE STATE OF WEST VIRGINIA FOR WHICH BIDS WERE SOLICITED ON OR AFTER JUNE 6, 2001.</p>						

SEE REVERSE SIDE FOR TERMS AND CONDITIONS

SIGNATURE	TELEPHONE	DATE
-----------	-----------	------

TITLE	FEIN	ADDRESS CHANGES TO BE NOTED ABOVE
-------	------	-----------------------------------

WHEN RESPONDING TO RFQ, INSERT NAME AND ADDRESS IN SPACE ABOVE LABELED 'VENDOR'



State of West Virginia
 Department of Administration
 Purchasing Division
 2019 Washington Street East
 Post Office Box 50130
 Charleston, WV 25305-0130

Request for Quotation

RFQ NUMBER:
 07110156

PAGE:
 4

ADDRESS CORRESPONDENCE TO ATTENTION OF:
 BUYER 33
 304-558-2402

RFQ COPY
 TYPE NAME/ADDRESS HERE

SUBJECT

Flintington, WV E 8347
 Route 1, 351 Clement's Road

SUBJECT

DIVISION OF HIGHWAYS
 DISTRICT SEVEN
 STORAGE YARD
 1205 US HWY 19 SOUTH
 WESTON, WV
 26452 304-269-0475

LANMATT INC.

DATE PRINTED	TERMS OF SALE	SHIP VIA	FOB	FREIGHT TERMS
12/22/2010				

BID OPENING DATE: 01/26/2011 BID OPENING TIME 01:30PM

LINE	QUANTITY	UOP	CAT. NO.	ITEM NUMBER	UNIT PRICE	AMOUNT
				B.	"STEEL PRODUCTS" MEANS PRODUCTS ROLLED, FORMED, SHAPED, DRAWN, EXTRUDED, FORGED, CAST, FABRICATED OR OTHERWISE SIMILARLY PROCESSED, OR PROCESSED BY A COMBINATION OF TWO OR MORE OF SUCH OPERATIONS, FROM STEEL MADE BY THE OPEN HEARTH, BASIC OXYGEN, ELECTRIC FURNACE, BESSEMER OR OTHER STEEL MAKING PROCESS.	
				C.	"UNITED STATES" MEANS THE UNITED STATES OF AMERICA AND INCLUDES ALL TERRITORY, CONTINENTAL OR INSULAR, SUBJECT TO THE JURISDICTION OF THE UNITED STATES.	
2.					THE DIRECTOR OF THE PURCHASING DIVISION MAY, IN WRITING, AUTHORIZE THE USE OF FOREIGN STEEL PRODUCTS IF:	
				A.	THE COST FOR EACH CONTRACT ITEM USED DOES NOT EXCEED ONE TENTH OF ONE PERCENT (.1%) OF THE TOTAL CONTRACT COST OR TWO THOUSAND FIVE HUNDRED DOLLARS (2,500.00), WHICHEVER IS GREATER. FOR THE PURPOSES OF THIS SECTION, THE COST IS THE VALUE OF THE STEEL PRODUCT AS DELIVERED TO THE PROJECT OR,	
				B.	THE DIRECTOR OF THE PURCHASING DIVISION DETERMINES THAT SPECIFIED STEEL MATERIALS ARE NOT PRODUCED IN THE UNITED STATES IN SUFFICIENT QUANTITY OR OTHERWISE ARE NOT REASONABLY AVAILABLE TO MEET CONTRACT REQUIREMENTS.	
3.					A CONTRACTOR WHO USES STEEL PRODUCTS IN VIOLATION OF THIS SECTION MAY BE SUBJECT TO CIVIL PENALTIES PURSUANT TO WV CODE SECTION 5A-3-56.	

SEE REVERSE SIDE FOR TERMS AND CONDITIONS

SIGNATURE	TELEPHONE	DATE
TITLE	FEIN	ADDRESS CHANGES TO BE NOTED ABOVE

WHEN RESPONDING TO RFQ, INSERT NAME AND ADDRESS IN SPACE ABOVE LABELED 'VENDOR'



State of West Virginia
 Department of Administration
 Purchasing Division
 2019 Washington Street East
 Post Office Box 50130
 Charleston, WV 25305-0130

Request for Quotation

RFQ NUMBER
07110156

PAGE
5

ADDRESS CORRESPONDENCE TO ATTENTION OF
BUYER 33 304-558-2402

RFQ COPY

TYPE NAME/ADDRESS HERE

VENDOR

JAMATT INC.
 Route 1, 351 Cleman's Road
 Flemington, WV 26347

SHIP TO

DIVISION OF HIGHWAYS
 DISTRICT SEVEN
 STORAGE YARD
 1205 US HWY 19 SOUTH
 WESTON, WV 26452 304-269-0475

DATE PRINTED	TERMS OF SALE	SHIP VIA	FOB	FREIGHT TERMS
12/22/2010				

BID OPENING DATE: **01/26/2011** BID OPENING TIME **01:30PM**

LINE	QUANTITY	UOP	CAT. NO.	ITEM NUMBER	UNIT PRICE	AMOUNT
REV. 10/01/01						
NOTICE						
A SIGNED BID MUST BE SUBMITTED TO:						
DEPARTMENT OF ADMINISTRATION PURCHASING DIVISION BUILDING 15 2019 WASHINGTON STREET, EAST CHARLESTON, WV 25305-0130						
THE BID SHOULD CONTAIN THIS INFORMATION ON THE FACE OF THE ENVELOPE OR THE BID MAY NOT BE CONSIDERED:						
SEALED BID						
BUYER:				SHERI SLONE-FILE 33		
RFQ. NO.:				07110156		
BID OPENING DATE:				01/26/2011		
BID OPENING TIME:				1:30 PM		
PLEASE PROVIDE A FAX NUMBER IN CASE IT IS NECESSARY TO CONTACT YOU REGARDING YOUR BID:						
----- <u>304-842-2634</u> -----						

SEE REVERSE SIDE FOR TERMS AND CONDITIONS

SIGNATURE	TELEPHONE	DATE
TITLE	FEIN	ADDRESS CHANGES TO BE NOTED ABOVE

WHEN RESPONDING TO RFQ, INSERT NAME AND ADDRESS IN SPACE ABOVE LABELED 'VENDOR'

Bid Schedule for #

07110156

JAMATT INC.

6

Route 1, 351 Clemen's Road
Flemington, WV 26347

Item No.	Quantity	Description	Unit Price	Amount
1.	10,200	lb. W Shape Structural Steel AASHTO M270 Grade 50 5 pieces W-10 X 68, 30 ft. long.	# <u>132</u>	# <u>13,464⁰⁰</u>
2.	654	lb. Structural Steel Plate AASHTO M270 Grade 50 2 pieces 3/4" x 8" x 16' w/ 1 1/2" holes	<u>150</u>	<u>981⁰⁰</u>
3.	3,063	lb. Structural Steel Plate AASHTO M270 Grade 50 2 pieces 3/4" x 2' 6" x 20'	<u>140</u>	<u>4288²⁰</u>
4.	164.	lb. C Shape Structural Steel AASHTO M270 Grade 50 4 pieces C-6 X 13, 3' 1 3/4" long. (Diaphragm Assembly)	<u>175</u>	<u>287⁰⁰</u> 567⁰⁰
5.	21	lb. Structural Steel Plate AASHTO M270 Grade 50 8 pieces 3/8" x 3 1/2" x 7" w/ 13/16" holes (Diaphragm Assembly)	<u>150</u>	<u>3150</u>
6.	22	lb. Structural Steel Plate AASHTO M270 Grade 50 4 pieces 3/4" x 5" x 5" w/ 1 5/16" holes	<u>150</u>	<u>33⁰⁰</u>
7.	4	ea. Galvanized All-Thread Bars w/Double Nuts and Washer 1" x 18"	<u>20⁰⁰</u>	<u>80⁰⁰</u>
8.	16	ea. Exterior High Strength Bolt w/ nut and washer 3/4" x 2"	<u>350</u>	<u>56⁰⁰</u>
Total \$			<u>19,220⁷⁰</u>	

Note:

All Stringers, Abutment Caps, Back-wall Plates, and Guardrail Assemblies for Bear Fork W-Bridge Project No. S311-8-5.23 are to be fabricated in accordance with WVDOH Standard Specifications, Nov. 2010 Section 709.12 (see attachment). After fabrication, all steel shall be galvanized according to WVDOH Standard Specifications, Nov. 2010, section 689 (see attachment). All plans/drawings are also attached for reference. All cutting, drilling, welding and galvanizing shown on the plans shall be included in this price. Foreign steel will not be accepted. All lab reports must accompany the shipping ticket.

SECTION 689 METALIZING STEEL

689.1-DESCRIPTION:

This specification covers the requirements for thermal spray metallic coatings, with or without sealers or top coats, as a means to prevent corrosion of steel surfaces.

All work shall be done at the steel fabrication shop unless otherwise specified.

The requirements outlined in the Society of Protective Coatings Guide for "Thermal Spray Metallic Coating Systems" (SSPC CS-Guide 23.00) shall be followed and considered as part of this specification.

689.2-MINIMUM REQUIREMENTS:

All metalizing work shall be performed by a company with at least three years of experience in coating steel. Any company which is new to metalizing and does not have three years experience shall, prior to starting any work, submit written documentation of successful structural steel metalizing projects. This shall include the name of the owner of previous projects, number and location of jobs completed, and number of years experience. This document will be reviewed, verified, and approved by the Engineer prior to beginning any work. The company shall possess knowledge and experience in all areas of surface preparation and metalizing work.

Each spray operator shall be qualified to metalize in conformance with the latest edition of ANS/AWS C2.18. Spray operators not having evidence of qualification shall be prohibited from spraying.

689.3-MATERIAL:

Unless otherwise specified, the metallic coating to be applied shall be pure zinc, conforming to the requirements of ASTM B6.

The manufacturer shall furnish a Certificate of Analysis for each lot of material supplied. Each container or coil reel shall be properly labeled to identify component type, supplier, size, and wire lot number.

The size of wire material shall conform to the manufacturer's recommendations for the Arc Sprayed method.

The metalizing material shall satisfy the requirements for at least a Class B slip coefficient and creep resistant per Appendix A of the "Specification for Structural Joints Using ASTM A 325 or A 490 Bolts" by the Research Council on Structural Connections. The test results shall be provided to the Engineer by the contractor prior to the start of work.

689.4-APPLICATION OF METALLIC COATING:

The metalizing unit shall be an arc type gun manufactured by an established domestic company. The equipment shall be used in conformance with the manufacturer's recommendations. No surface shall be sprayed which shows any signs of rust, scale or moisture. All metalizing shall be applied at 8 - 14 mils (200 - 350 μm) with no individual reading less than 6 mils (150 μm) nor more than 16 mils (400 μm). Field and/or shop bolted contact surfaces shall have the coating applied in the range of 2 to 5 mils (25-125 μm) dry film thickness. At least one layer of coating shall be applied within four hours after blasting and the final

thickness within a maximum of eight hours of the blasting. The steel shall be cleaned with sharp, angular grit, to at least a near white finish meeting SSPC-SP-10. No shot will be allowed as the blasting abrasive. The profile of the anchor pattern shall be 2-4 mils (50-100 μm).

The top flange which will require shear studs shall have the metalizing applied at a minimum of 2 mils (50 μm) in order to prevent rusting. If applied in the shop, the studs shall be installed prior to metalizing. Metalizing of the studs is not required. If installed in the field, the shop applied metalizing on the top of the top flange shall be removed at the stud locations to bare metal prior to installation of the studs.

The contractor shall provide facilities to protect the finished metalized surface from damage during the blasting and thermal spraying work operations on adjacent areas. All damaged coated areas shall be properly repaired and remetalized at no additional cost to the Division.

Surfaces not intended to be metalized shall be suitably protected from the effects of the metalizing operations.

689.5-SEALERS AND TOP COATS:

The Division has the option of requiring a sealer and/or top coats over the metalizing. When this option is chosen, the requirements will be specified in the contract documents.

689.6-SHIPPING AND HANDLING:

All fully coated and cured assemblies shall be protected from handling and shipping damage with the prudent use of padded slings, dunnage, separators and tie downs. Loading procedures and sequences shall be designed to protect all coated surfaces. Any damaged areas shall be repaired in conformance with the manufacturer's recommendations or as directed by the Engineer.

689.7-FIELD TOUCH UP:

All touch up for metalizing shall be in conformance with the coaters recommendations.

689.8-METHOD OF MEASUREMENT:

The unit of measurement for "Metalizing Steel" shall be lump sum.

689.9-BASIS OF PAYMENT:

Basis of payment for "Metalizing Steel" shall be lump sum. Payment shall be full compensation for furnishing all the labor, tools, equipment, supplies, and incidentals necessary to complete the work herein prescribed.

689.10-PAY ITEMS:

Item	Description	Unit
689001-*	Metalizing Steel	Lump Sum
689002-*	Metalizing Steel With Sealer	Lump Sum
689003-*	Metalizing Steel With Sealer And Top Coats	Lump Sum

* Sequence Number

709.8-HIGH STRENGTH LOW ALLOY STRUCTURAL METAL:

High-strength structural steel for bridges shall conform to AASHTO M270, grades 50, 50W, or HPS 70W. High-strength steel for all other applications shall conform to AASHTO M222 (weathering) or AASHTO M223.

709.9-BLANK**709.10-GRAY IRON, MALLEABLE IRON AND DUCTILE IRON CASTINGS:**

Gray iron castings shall conform to the requirements of AASHTO M 105, Class No. 30.

Malleable iron castings shall conform to the requirements of ASTM A 47, Grade 32510. Castings shall be boldly filleted at angles, and the arrises shall be sharp and perfect.

Malleable iron castings for railings posts shall be Grade No. 32510 and shall be galvanized with hot-dipped zinc coating in accordance with AASHTO M 232.

Ductile iron castings shall conform to the requirements of ASTM A-536, Grade 80-55-6, 65-45-12 or 60-40-18.

The dimension tolerance for gray iron castings is $\pm 1/16$ inch per foot (5.2 mm per meter) and the weight tolerance is $\pm 5\%$.

All castings shall contain a manufacturer's heat number, lot number, or cast date. This identification shall be cast into the material at the time of manufacturer.

709.11-BLANK**709.12-STRUCTURAL AND EYEBAR STEEL:**

All structural steel for bridges shall conform to the applicable grade of AASHTO M270 that is specified in the Plans. When no specific grade is called for, AASHTO M270, Grade 36 shall be used. Non-designated structural steel in all other sections of the Specifications shall conform to ASTM A36.

709.13-STEEL FORGINGS AND STEEL SHAFTING:

709.13.1-Steel Forgings: Steel forgings shall conform to AASHTO M 102, Class E. They shall be bored as specified in 615.4.9.2. A record of the annealing or normalizing changes shall be furnished showing the forgings in such charge, the melt or melts from which they were secured and the treatment they received.

709.13.2-Steel Shafting: Cold finished carbon steel shafting shall conform to AASHTO M169 Grades 1016 through 1030, inclusive, unless otherwise specified.

709.14-STEEL CASTINGS:

Steel castings shall conform to the requirements of AASHTO, M 103, except steel produced by the converter process shall not be used. All steel castings shall be grade 65-35 (450-240). Sharp unfileted angles or corners shall not be permitted.

To reference the 2010 WVDOT Standard Specifications for Roads and Bridges visit the following site:

<http://www.transportation.wv.gov/highways/contractadmin/specifications/Documents/2010%20Standard%20Specifications%20Roads%20and%20Bridges/Complete%20Publications/2010StandardRoadsnBridges.pdf>

WEST VIRGINIA DEPARTMENT OF TRANSPORTATION DIVISION OF HIGHWAYS SUPERSTRUCTURE REPLACEMENT OF

BEAR FORK I-BEAM
STATE PROJECT NO. S311-8-5.23
C.R. 8 (SLS)
FREEMANS CREEK DISTRICT
GILMER COUNTY

PROJECT LENGTH

BRIDGE STA. 0+00.00 TO STA. 0+26.94 = 26.94 L.F. = 0.005 MI.
TOTAL LENGTH = 26.94 L.F. = 0.005 MI.

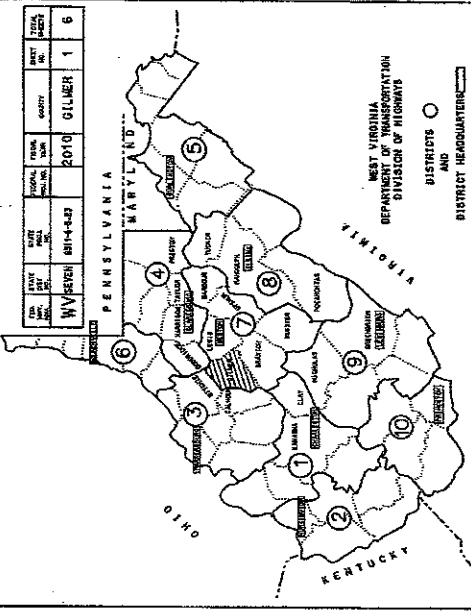
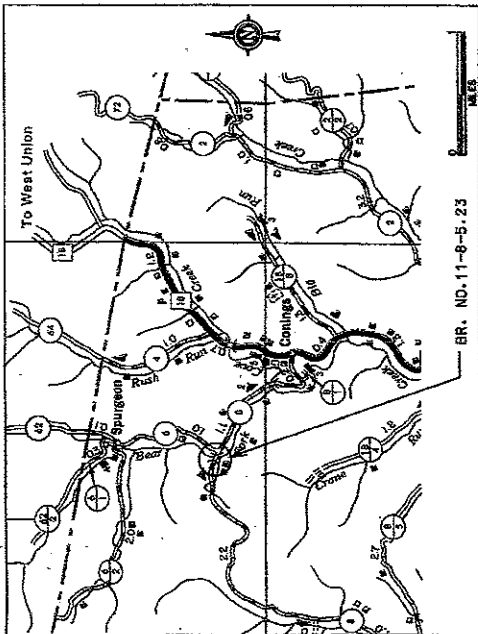

UTILITIES ENCOUNTERED:

- CONVENTIONAL SIGNS**
- STATE LINE
 - COMPARISON LINE
 - PROPOSED R/W LINE
 - PROPERTY LINE
 - EXISTING FENCE
 - EDGE OF STREAM
 - PROPOSED QUADRANT
 - EXISTING QUADRANT
 - RAILROAD
 - GAS LINE
 - WATER LINE
 - TELEPHONE LINE
 - TELEPHONE POLE
 - POWER POLE
 - CONDITIONED POWER AND TELEPHONE POLE
 - SHIELD
 - RIGHT OF WAY MARKER

TYPE OF CONSTRUCTION SUPERSTRUCTURE REPLACEMENT BR. NO. 11-8-5.23 (7917.1)

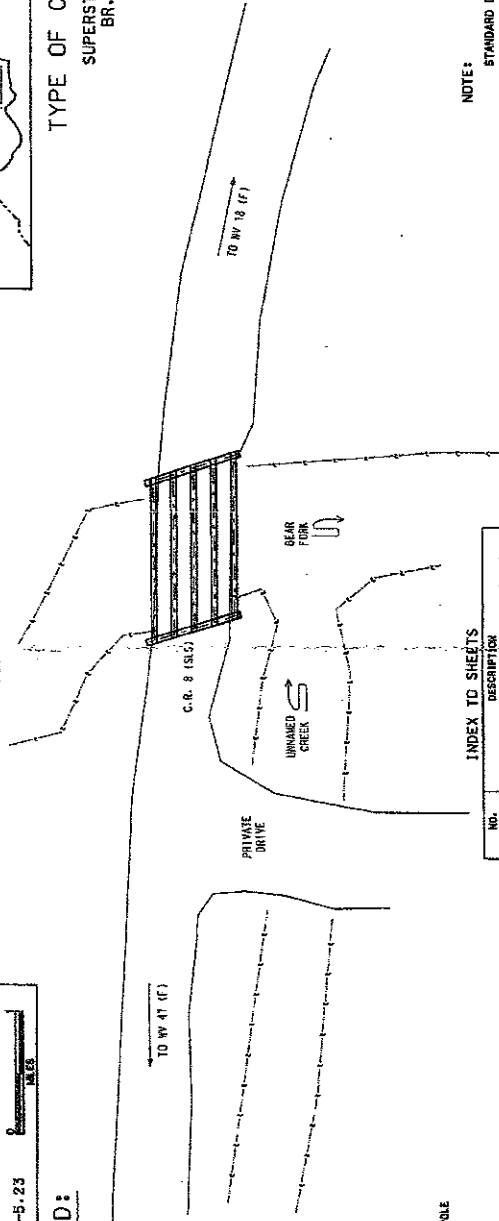

NO.	DESCRIPTION
1	TITLE SHEET
2	GENERAL NOTES
3	EXISTING ELEVATION MAP AND ROAD SECTION, ESTIMATE OF QUANTITIES, AND BIDDING PLAN
4	PROPOSED ROAD SECTION, SIDE, CROWN, AND BEARING DETAILS, ELEVATION THEM, ABUT., RETAINS, AND CURBROAD DETAILS.
5	ROLLING CURBROAD AND SIDE G.I.P. DETAILS.
6	
7	
8	
9	
10	

NOTE: STANDARD DETAIL BOOK VOLUME 1, DATED JAN. 1, 2000 & VOLUME 11 DATED JAN. 1, 1994, SHALL APPLY TO THIS PROJECT.

NO.	DATE
BR-2A	8-23

PREPARED BY:	DATE
BKR	05-10
CHECKED BY:	DATE
OPL	06-10
REVIEWED BY:	DATE
HRW	06-10

DESIGN DESIGNATION	BY	DATE
A.D.T. (2006)	50	
A.D.T. (2026)	50	
D.H.V.		
D.		
T.		
V.		

SECTION NAME	PAGE NUMBER	REVISIONS	DATE	BY

RECOMMENDED FOR APPROVAL: *Bradley J. Rere*
 RECOMMENDED FOR APPROVAL: *Ron Nielson*
 RECOMMENDED FOR APPROVAL: *Robert M. ...*
 APPROVED: *...*

I HEREBY CERTIFY THAT THIS IS A CORRECT COPY OF THE PLANS OF PROJECT S311-8-5.23
Dorson Davis 7-16-10
 DISTRICT ENGINEER

PROJECT NO.	PROJECT NUMBER	COUNTY	SHEET NO.	TOTAL SHEETS
1511-1-12	5111-1-12	CLINGER	7	6

GOVERNING SPECIFICATIONS

The governing specifications to be followed are the West Virginia Department of Highway Safety, Standard Specifications for Road and Bridge Construction, and the Standard Specifications for Road and Bridge Construction, published by the West Virginia Department of Highways, the former part and the latter part, as amended.

Contract Requirements and Specifications shall be the Specifications in effect on the last day of actual advertisement if they are in conflict.

DESIGN-NEW STRUCTURES

This bridge is designed to be in full load capacity, as well as for a 50-year service life.

Design Load: HS-20

Design Wind: 90 mph

Design Flood: 100 year return period

Design Ice: 6 inches

Design Temperature: 100°F

Design Seismicity: 0.15g

DESIGN-REHABILITATION AND STRENGTHENING

This bridge is designed for a design load of HS-20. Strengthening shall be in accordance with the Standard Specifications for Road and Bridge Construction, published by the West Virginia Department of Highways, the former part and the latter part, as amended.

CONCRETE (CAST-IN-PLACE)

Concrete shall be used in accordance with Section 505 of the Standard Specifications, unless otherwise specified. The concrete shall be placed and cured in accordance with the Standard Specifications for Road and Bridge Construction, published by the West Virginia Department of Highways, the former part and the latter part, as amended.

SUBSTRUCTURE CONCRETE (CAST-IN-PLACE)

Reinforcement in the substructure shall be Class A steel. The reinforcement shall be placed and cured in accordance with the Standard Specifications for Road and Bridge Construction, published by the West Virginia Department of Highways, the former part and the latter part, as amended.

SUBSTRUCTURE CONCRETE (CAST-IN-PLACE)

Reinforcement in the substructure shall be Class A steel. The reinforcement shall be placed and cured in accordance with the Standard Specifications for Road and Bridge Construction, published by the West Virginia Department of Highways, the former part and the latter part, as amended.

REINFORCING STEEL BARS

Reinforcing steel bars shall be furnished in accordance with Section 505 of the Standard Specifications, unless otherwise specified. The bars shall be placed and cured in accordance with the Standard Specifications for Road and Bridge Construction, published by the West Virginia Department of Highways, the former part and the latter part, as amended.

STRUCTURE-EXCAVATION FOOTINGS (FOUNDED IN ROCK)

Excavation shall be made in accordance with Section 505 of the Standard Specifications, unless otherwise specified. The excavation shall be founded in rock and shall be finished in accordance with the Standard Specifications for Road and Bridge Construction, published by the West Virginia Department of Highways, the former part and the latter part, as amended.

STEEL TOUGHNESS REQUIREMENT

The provisions of the ASTM A570 Specification for steel bars shall be followed. The steel bars shall be furnished in accordance with the Standard Specifications for Road and Bridge Construction, published by the West Virginia Department of Highways, the former part and the latter part, as amended.

PAINTING (NEW STRUCTURES)

Steel and lead painting shall be in accordance with Section 508 of the Standard Specifications for Road and Bridge Construction, published by the West Virginia Department of Highways, the former part and the latter part, as amended.

CLEANING AND PAINTING (EXISTING STRUCTURES)

Steel and lead painting shall be in accordance with Section 508 of the Standard Specifications for Road and Bridge Construction, published by the West Virginia Department of Highways, the former part and the latter part, as amended.

PREPARED ELASTOMERIC JOINT SEALER

The provisions of the ASTM A570 Specification for steel bars shall be followed. The steel bars shall be furnished in accordance with the Standard Specifications for Road and Bridge Construction, published by the West Virginia Department of Highways, the former part and the latter part, as amended.

STRUCTURE-EXCAVATION FOOTINGS (FOUNDED ON PILES)

Excavation shall be made in accordance with Section 505 of the Standard Specifications, unless otherwise specified. The excavation shall be founded on piles and shall be finished in accordance with the Standard Specifications for Road and Bridge Construction, published by the West Virginia Department of Highways, the former part and the latter part, as amended.

BRIDGE GUARDRAIL

The guardrail shall be in accordance with Section 505 of the Standard Specifications for Road and Bridge Construction, published by the West Virginia Department of Highways, the former part and the latter part, as amended.

STRUCTURAL STEEL

Structural steel shall be furnished in accordance with Section 505 of the Standard Specifications for Road and Bridge Construction, published by the West Virginia Department of Highways, the former part and the latter part, as amended.

STEEL GRID FLOORING (CONCRETE FILLER TYPE)

Steel grid flooring shall be furnished in accordance with Section 505 of the Standard Specifications for Road and Bridge Construction, published by the West Virginia Department of Highways, the former part and the latter part, as amended.

STEEL GRID FLOORING (OPEN TYPE)

Steel grid flooring shall be furnished in accordance with Section 505 of the Standard Specifications for Road and Bridge Construction, published by the West Virginia Department of Highways, the former part and the latter part, as amended.

MAINTAINING TRAFFIC

Traffic shall be maintained in accordance with Section 505 of the Standard Specifications for Road and Bridge Construction, published by the West Virginia Department of Highways, the former part and the latter part, as amended.

MAIL LAMINATED WOOD DECK

The deck shall be in accordance with Section 505 of the Standard Specifications for Road and Bridge Construction, published by the West Virginia Department of Highways, the former part and the latter part, as amended.

PRESTRESSED CONCRETE SUPERSTRUCTURE

Prestressed concrete superstructure shall be furnished in accordance with Section 505 of the Standard Specifications for Road and Bridge Construction, published by the West Virginia Department of Highways, the former part and the latter part, as amended.

GENERAL NOTES

The provisions of the ASTM A570 Specification for steel bars shall be followed. The steel bars shall be furnished in accordance with the Standard Specifications for Road and Bridge Construction, published by the West Virginia Department of Highways, the former part and the latter part, as amended.

GENERAL NOTES

The provisions of the ASTM A570 Specification for steel bars shall be followed. The steel bars shall be furnished in accordance with the Standard Specifications for Road and Bridge Construction, published by the West Virginia Department of Highways, the former part and the latter part, as amended.

NOTE SELECTION TABLE		CONTROL VALUE	
NO.	DESCRIPTION	MIN.	MAX.
1	PAINTING (NEW STRUCTURES)	1	1
2	DESIGN-NEW STRUCTURES	1	1
3	DESIGN-REHABILITATION AND STRENGTHENING	1	1
4	CONCRETE (CAST-IN-PLACE)	1	1
5	SUBSTRUCTURE CONCRETE (CAST-IN-PLACE)	1	1
6	REINFORCING STEEL BARS	1	1
7	STRUCTURE-EXCAVATION FOOTINGS (FOUNDED IN ROCK)	1	1
8	STEEL TOUGHNESS REQUIREMENT	1	1
9	BRIDGE GUARDRAIL	1	1
10	STRUCTURAL STEEL	1	1
11	STEEL GRID FLOORING (CONCRETE FILLER TYPE)	1	1
12	STEEL GRID FLOORING (OPEN TYPE)	1	1
13	MAINTAINING TRAFFIC	1	1
14	MAIL LAMINATED WOOD DECK	1	1
15	PRESTRESSED CONCRETE SUPERSTRUCTURE	1	1

THE WEST VIRGINIA DEPARTMENT OF TRANSPORTATION
DIVISION OF HIGHWAY STRUCTURES

STRUCTURE REPLACEMENT PLANS OF
BEAR FORK VI-BEAM
ON CH. 8 (IS)
OVER BEAR FORK
CLINGER COUNTY

BRIDGE NUMBER
11-0-123
(7811-1)

GENERAL NOTES

1. These items are for Review Only.

2. The provisions of the ASTM A570 Specification for steel bars shall be followed. The steel bars shall be furnished in accordance with the Standard Specifications for Road and Bridge Construction, published by the West Virginia Department of Highways, the former part and the latter part, as amended.

ESTIMATE OF QUANTITIES
 PROJECT NO. 3311-8-5-23
 FOR INFORMATION ONLY

DESCRIPTION	UNITS	NO. AND SIZE	TOTAL
DECK TIMBER	EA	2" X 6" X 18'	210
TIMBER CURB	EA	6" X 6" X 12'	2
TIMBER BLOCKOUT	EA	6" X 6" X 10'	4
NAILING CLIPS	EA	6" X 6" X 15'	4
STRINGERS	EA	20 FEET	100
BEARING PLATES	EA	18" X 6"	135
BACKWALL PLATES	EA	5'-10" X 6" X 20'	10200
W/ADDITIONAL ASSEMBLIES	EA	2'-3/4" X 8" X 15'	654
W/ADDITIONAL ASSEMBLIES	EA	2'-3/4" X 2" X 6" X 20'	3053
W/ADDITIONAL ASSEMBLIES	EA	4'-2"	4
W/ADDITIONAL ASSEMBLIES	EA	2" X 6" X 4'	85
W/ADDITIONAL ASSEMBLIES	EA	3" X 3" X 8'	4
W/ADDITIONAL ASSEMBLIES	EA	W/OUT AND WASHER	16
W/ADDITIONAL ASSEMBLIES	EA	1" X 18" LONG	16
W/ADDITIONAL ASSEMBLIES	EA	1" LONG	4

* -ALL STRUCTURAL STEEL SHALL CONFORM TO THE REQUIREMENTS OF ASTM A223 GRADE 50 AND SHALL BE GALVANIZED AND FABRICATED AS SHOWN ON SHEETS 4 & 5 OF 6. GALVANIZING SHALL CONFORM TO THE WOOD SPECIFICATIONS, JAN 2003, FOR SECTION 689.

SCOPE OF WORK

1. REMOVE EXISTING DECK AND SUPERSTRUCTURE.
2. PLACE AND WELD NEW STRINGERS AND BACKWALL PLATES.
3. PLACE NEW TIMBER DECK.
4. REPAIR SHOULDERS AND APPROACHES.
5. SITE DRESS, SEED, AND MULCH ALL DISTURBED AREAS.

WEST VIRGINIA DEPT. OF TRANSPORTATION
 DIVISION OF HIGHWAYS
 DISTRICT SEVEN

SUPERSTRUCTURE REPLACEMENT PLANS OF
 BEAR FORK W/BEAM
 ON C. C. B (SLS)
 OVER BEAR FORK
 GILMER COUNTY

REVISION DATE BY
 REVISION DATE BY
 BKR 05-10
 05-10
 06-10

CHECKED BY
 06-10

REVISION DATE BY
 06-10

EXISTING ELEVATION AND END VIEW OF
 ESTIMATE OF QUANTITIES & SCOPE
 OF WORK

SHEET 3 OF 6
 11-8-23
 7917-1

PROJECT NUMBERS	WV COUNTY SHEET OF
FEDERAL	GILMER 4
STATE	
DISTRICT	
SEVEN	6

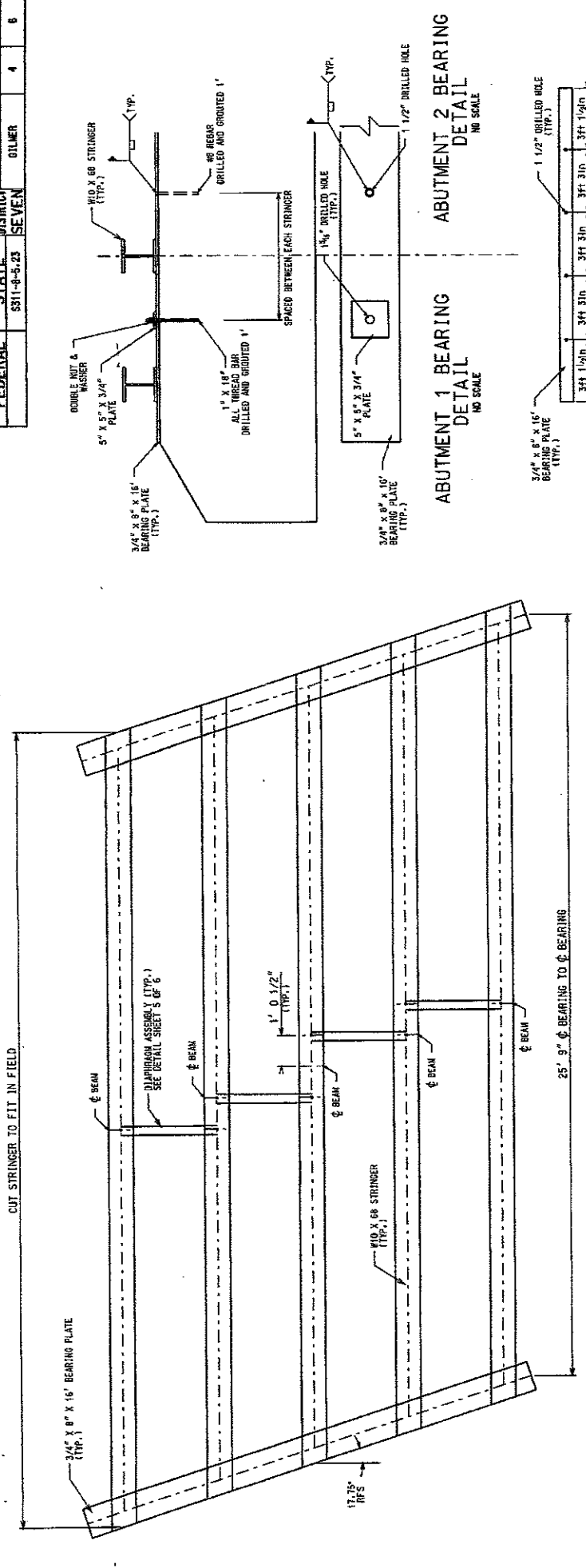

WEST VIRGINIA DEPT. OF TRANSPORTATION DIVISION OF HIGHWAYS DISTRICT SEVEN	
SUPERSTRUCTURE REPLACEMENT PLANS OF BEAR FORK W-BEAM BRIDGE OVER BEAR FORK GILMER COUNTY	
DESIGNED BY	6-10
CHECKED BY	06-10
APPROVED BY	06-10
SHEET 4 OF 6	PR. NO. 51-6-5-23 (7/17/11)

PROJECT NUMBERS	WV	COUNTY	SHEET	OF
FEDERAL	STATE	DISTRICT	5	6
S311-9-9-23	SEVEN	OTHER		

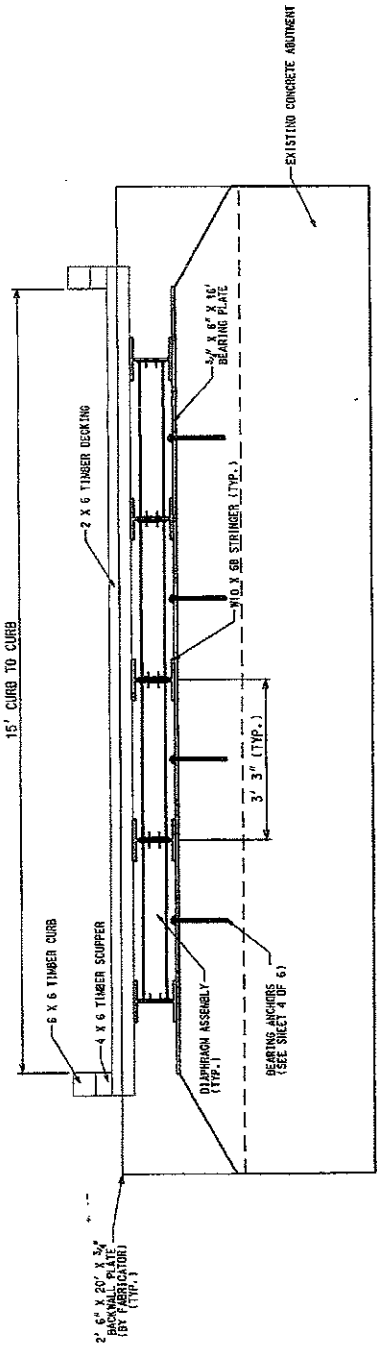

TYPICAL ABUTMENT DETAIL
NO SCALE

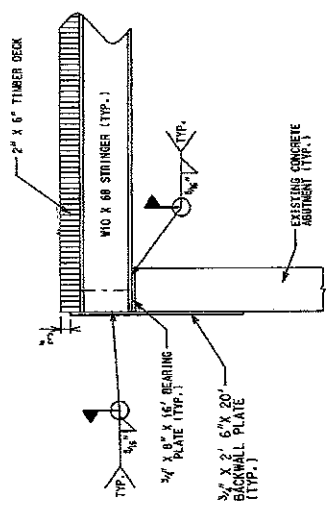

PROFILE WELD DETAIL
NO SCALE

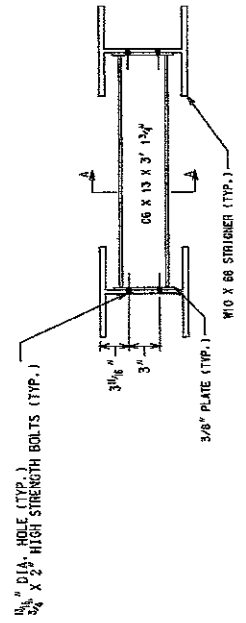

DIAPHRAGM ASSEMBLY DETAIL
NO SCALE

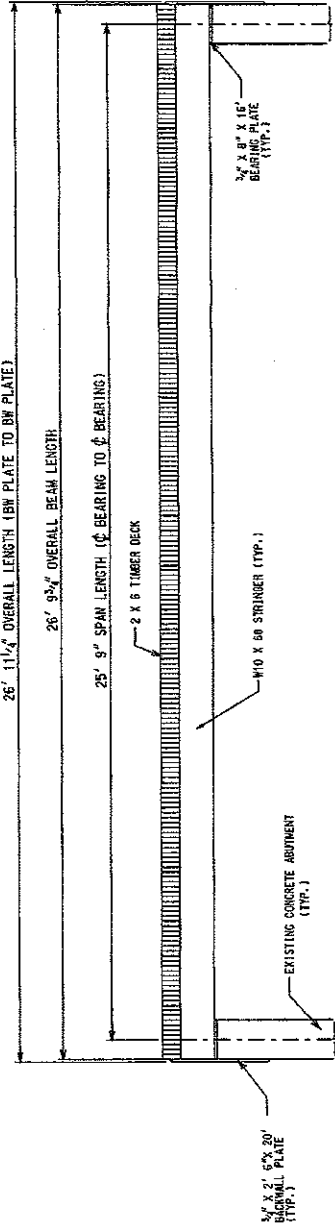
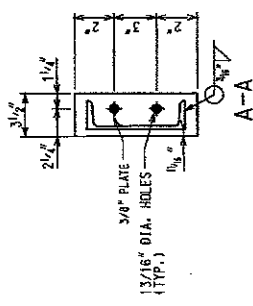

ELEVATION VIEW
NO SCALE

WEST VIRGINIA DEPT. OF TRANSPORTATION DIVISION OF HIGHWAYS DISTRICT SEVEN		SUPERSTRUCTURE REPLACEMENT PLANS OF BEAR FORK W-BEAM BRIDGE OVER BEAR FORK GILMER COUNTY	
REVISIONS DATE BY	05-10	05-10	06-10
DESIGN BY	05-10	05-10	06-10
CHECKED BY	05-10	05-10	06-10
DESIGNED BY	05-10	05-10	06-10
APPROVED BY	05-10	05-10	06-10
SCALE			
ELEVATION VIEW, ABUT. DETAILS, DIAPHRAGM DETAILS, & WELD DETAILS.		SHEET	5 OF 6
		DC-HO-11-4-6-23 (1977-11)	

PROJECT NUMBERS	WV DISTRICT	COUNTY	SHEET	OF
FEDERAL	STATE	SEVEN	6	6
S311-6-3-23		GILMER		

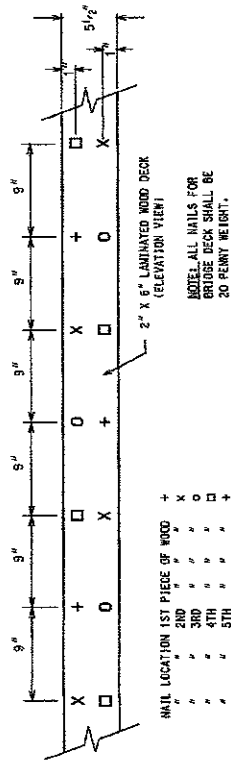

TIMBER DECK NAILING DIAGRAM
NO SCALE

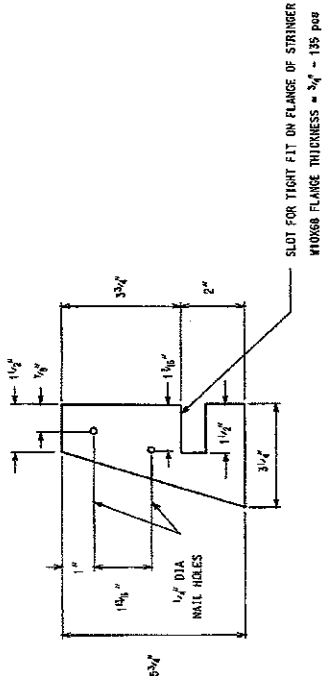

DECK ANCHOR PLATE DETAILS
NO SCALE

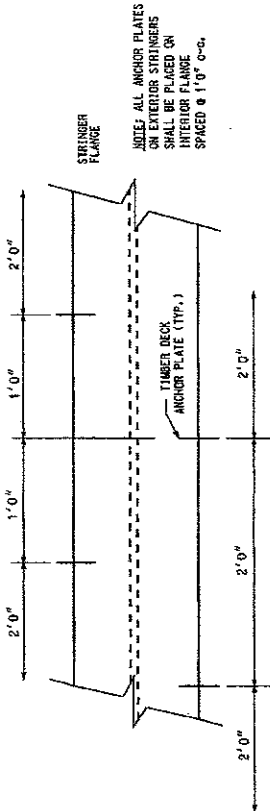

DECK ANCHOR PLATE SPACING DETAIL
(INTERIOR STRINGER)
NO SCALE

WEST VIRGINIA DEPT. OF TRANSPORTATION DIVISION OF HIGHWAYS DISTRICT SEVEN		SUPERSTRUCTURE REPLACEMENT PLANS OF BEAR FORK W-BEAM ON C.R. & (SLS) OVER BEAR FORK GILMER COUNTY	
REVISIONS DATE BY	DESIGNED BY	DATE	BY
	BR	05-10	BR
CHECKED BY	DATE	BY	
BR	05-10		
REVIEWED BY	DATE	BY	
BR	06-10		
MAILING AND DECK ANCHOR DETAILS		SHEET 6 OF 6	
		BR-HD.11-3-23 (1371.11)	



State of West Virginia
 Department of Administration
 Purchasing Division
 2019 Washington Street East
 Post Office Box 50130
 Charleston, WV 25305-0130

Request for Quotation

RFQ NUMBER
 07110156

PAGE
 1

ADDRESS CORRESPONDENCE TO ATTENTION OF
 BUYER 33
 304-558-2402

RFQ COPY
 TYPE NAME/ADDRESS HERE

VENDOR

JAMATT INC.
 Route 1, 351 Clemons Road
 Flemington, WV 26347

SHIP TO

DIVISION OF HIGHWAYS
 DISTRICT SEVEN
 STORAGE YARD
 1205 US HWY 19 SOUTH
 WESTON, WV
 26452 304-269-0475

DATE PRINTED	TERMS OF SALE	SHIP VIA	FOB	FREIGHT TERMS
01/21/2011				

BID OPENING DATE: 02/01/2011 BID OPENING TIME 01:30PM

LINE	QUANTITY	UCP	CAT. NO.	ITEM NUMBER	UNIT PRICE	AMOUNT
ADDENDUM NO. 1						
THIS ADDENDUM IS ISSUED TO						
1.) PROVIDE REVISED PLAN SHEETS						
2.) EXTEND THE BID OPENING DATE FROM						
01/26/2011 AT 1:30 PM TO 02/01/2011 AT 1:30 PM						
*****END ADDENDUM NO. 1*****						
0001	1	LB		570-84	\$19,220 ⁷⁰	\$19,220 ⁷⁰
TO PROVIDE STRUCTURAL STEEL FOR BEAR FORK W BEAM						
***** THIS IS THE END OF RFQ 07110156 ***** TOTAL:						\$19,220 ⁷⁰

SEE REVERSE SIDE FOR TERMS AND CONDITIONS

SIGNATURE <i>James C. Madhugh</i>	TELEPHONE 304-842-0367	DATE 01/29/2011
TITLE PRESIDENT	FEIN 20-1894398	ADDRESS CHANGES TO BE NOTED ABOVE

WHEN RESPONDING TO RFQ, INSERT NAME AND ADDRESS IN SPACE ABOVE LABELED 'VENDOR'

GENERAL TERMS & CONDITIONS REQUEST FOR QUOTATION (RFQ) AND REQUEST FOR PROPOSAL (RFP)

1. Awards will be made in the best interest of the State of West Virginia.
2. The State may accept or reject in part, or in whole, any bid.
3. Prior to any award, the apparent successful vendor must be properly registered with the Purchasing Division and have paid the required \$125 fee.
4. All services performed or goods delivered under State Purchase Order/Contracts are to be continued for the term of the Purchase Order/Contracts, contingent upon funds being appropriated by the Legislature or otherwise being made available. In the event funds are not appropriated or otherwise available for these services or goods this Purchase Order/Contract becomes void and of no effect after June 30.
5. Payment may only be made after the delivery and acceptance of goods or services.
6. Interest may be paid for late payment in accordance with the *West Virginia Code*.
7. Vendor preference will be granted upon written request in accordance with the *West Virginia Code*.
8. The State of West Virginia is exempt from federal and state taxes and will not pay or reimburse such taxes.
9. The Director of Purchasing may cancel any Purchase Order/Contract upon 30 days written notice to the seller.
10. The laws of the State of West Virginia and the *Legislative Rules* of the Purchasing Division shall govern the purchasing process.
11. Any reference to automatic renewal is hereby deleted. The Contract may be renewed only upon mutual written agreement of the parties.
12. **BANKRUPTCY:** In the event the vendor/contractor files for bankruptcy protection, the State may deem this contract null and void, and terminate such contract without further order.
13. **HIPAA BUSINESS ASSOCIATE ADDENDUM:** The West Virginia State Government HIPAA Business Associate Addendum (BAA), approved by the Attorney General, is available online at www.state.wv.us/admin/purchase/vrc/hipaa.htm and is hereby made part of the agreement. Provided that the Agency meets the definition of a Cover Entity (45 CFR §160.103) and will be disclosing Protected Health Information (45 CFR §160.103) to the vendor.
14. **CONFIDENTIALITY:** The vendor agrees that he or she will not disclose to anyone, directly or indirectly, any such personally identifiable information or other confidential information gained from the agency, unless the individual who is the subject of the information consents to the disclosure in writing or the disclosure is made pursuant to the agency's policies, procedures, and rules. Vendor further agrees to comply with the Confidentiality Policies and Information Security Accountability Requirements, set forth in <http://www.state.wv.us/admin/purchase/privacy/noticeConfidentiality.pdf>.
15. **LICENSING:** Vendors must be licensed and in good standing in accordance with any and all state and local laws and requirements by any state or local agency of West Virginia, including, but not limited to, the West Virginia Secretary of State's Office, the West Virginia Tax Department, and the West Virginia Insurance Commission. The vendor must provide all necessary releases to obtain information to enable the director or spending unit to verify that the vendor is licensed and in good standing with the above entities.
16. **ANTITRUST:** In submitting a bid to any agency for the State of West Virginia, the bidder offers and agrees that if the bid is accepted the bidder will convey, sell, assign or transfer to the State of West Virginia all rights, title and interest in and to all causes of action it may now or hereafter acquire under the antitrust laws of the United States and the State of West Virginia for price fixing and/or unreasonable restraints of trade relating to the particular commodities or services purchased or acquired by the State of West Virginia. Such assignment shall be made and become effective at the time the purchasing agency tenders the initial payment to the bidder.

I certify that this bid is made without prior understanding, agreement, or connection with any corporation, firm, limited liability company, partnership, or person or entity submitting a bid for the same material, supplies, equipment or services and is in all respects fair and without collusion or fraud. I further certify that I am authorized to sign the certification on behalf of the bidder or this bid.

INSTRUCTIONS TO BIDDERS

1. Use the quotation forms provided by the Purchasing Division. Complete all sections of the quotation form.
2. Items offered must be in compliance with the specifications. Any deviation from the specifications must be clearly indicated by the bidder. Alternates offered by the bidder as **EQUAL** to the specifications must be clearly defined. A bidder offering an alternate should attach complete specifications and literature to the bid. The Purchasing Division may waive minor deviations to specifications.
3. Unit prices shall prevail in case of discrepancy. All quotations are considered F.O.B. destination unless alternate shipping terms are clearly identified in the quotation.
4. All quotations must be delivered by the bidder to the office listed below prior to the date and time of the bid opening. Failure of the bidder to deliver the quotations on time will result in bid disqualifications: Department of Administration, Purchasing Division, 2019 Washington Street East, P.O. Box 50130, Charleston, WV 25305-0130
5. Communication during the solicitation, bid, evaluation or award periods, except through the Purchasing Division, is strictly prohibited (W.Va. C.S.R. §148-1-6.6).

WEST VIRGINIA DEPARTMENT OF TRANSPORTATION DIVISION OF HIGHWAYS SUPERSTRUCTURE REPLACEMENT OF

BEAR FORK I-BEAM
STATE PROJECT NO. S311-8-5.23
C.R. 8 (SLS)
FREEMANS CREEK DISTRICT
GILMER COUNTY

PROJECT LENGTH

BRIDGE STA. 0+00.00 TO STA. 0+26.94 = 26.94 L.F. = 0.005 MI.
TOTAL LENGTH = 26.94 L.F. = 0.005 MI.

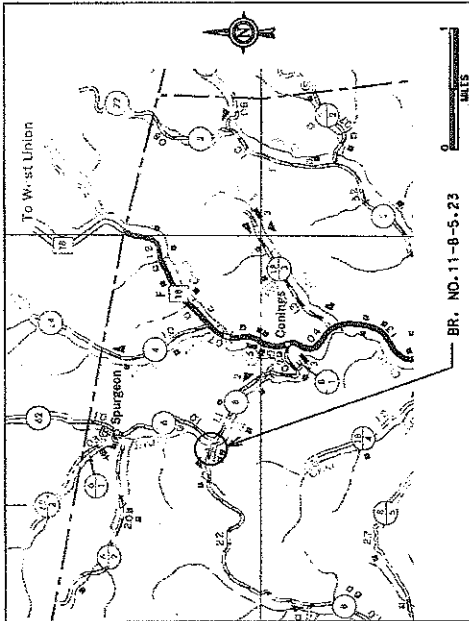

UTILITIES ENCOUNTERED:

- CONVENTIONAL SIGNS**
- STATE LINE
 - COUNTY LINE
 - CORPORATION LINE
 - PROPERTY LINE
 - EXISTING FENCE
 - DITCH OR STREAM
 - PROPOSED GUARDRAIL
 - EXISTING GUARDRAIL
 - RAILROAD
 - GAS LINE
 - WATER LINE
 - TELEPHONE LINE
 - TELEPHONE POLE
 - POWER POLE
 - COMBINED POWER AND TELEPHONE POLE
 - SHRUB
 - RIGHT OF WAY MARKER

STANDARD SHEETS

NO.	DATE
BR-2A	8-93

DESIGN DESIGNATION

A.P.T. (2006)	50
A.D.T. (2026)	60
D.H.V.	
D.	
T.	
V.	

INDEX TO SHEETS

NO.	DESCRIPTION
1	TITLE SHEET
2	GENERAL NOTES
3	EXISTING ELEVATION VIEW AND CROSS SECTION, CELESTIAL OF QUANTITIES AND SCOPE OF WORK.
4	PROPOSED CROSS SECTION, STEEL LAYOUT, AND BEARING DETAILS.
5	ELEVATION VIEW, ABUT. DETAILS, AND DIMENSION DETAILS.
6	MAILING ENVELOPE AND BICYCLE CLIP DETAILS.

PREPARED BY:	DATE
BKR	05-10
CHECKED BY:	DATE
OFL	05-10
REVIEWED BY:	DATE
TRV	06-10

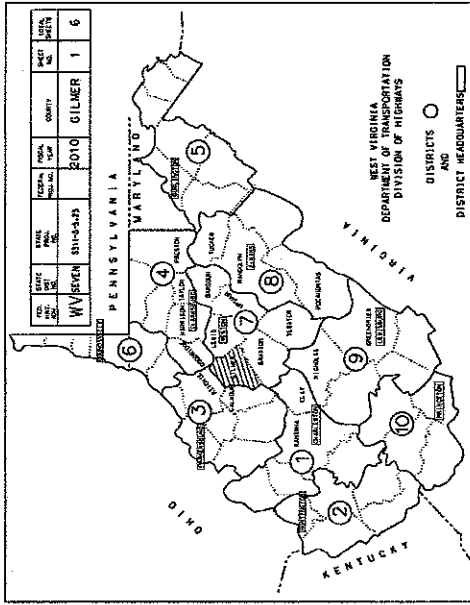

TYPE OF CONSTRUCTION
SUPERSTRUCTURE REPLACEMENT
BR. NO. 11-8-5.23
(7917.1)

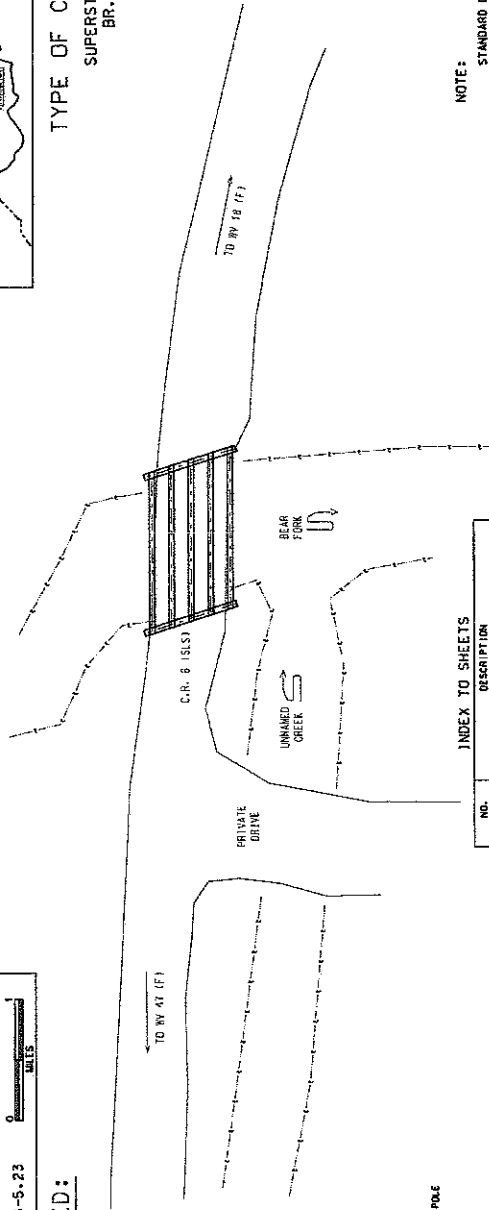

SCALE 1"=40'

NOTE:
STANDARD DETAIL BOOK VOLUME 1, DATED JAN. 1, 2000
& VOLUME 11 DATED JAN. 1, 1994, SHALL APPLY TO THIS
PROJECT.

REVISION NUMBER	REVISIONS	DATE	BY

RECOMMENDED	SECTIONS
RECOMMENDED FOR APPROVAL	DISTRICT MANAGER
RECOMMENDED FOR APPROVAL	DISTRICT HIGHWAY ENGINEER
APPROVED	COMMITTEE CHIEF OF HIGHWAYS

FOR REVIEW BY THE U.S. CORPUS OF
COPY OF THE PLANS OF PROJECT S311-8-5.23

EXECUTIVE SECRETARY

PROJECT NO. S311-8-5.23

TABLE NO.	PROJECT NUMBER	COUNTY	SHEET TOTAL
10-VA	5311-8-5-23	01060	2 of 6

GOVERNING SPECIFICATIONS

The governing provisions applicable to this project are the West Virginia Department of Highways Standard Specifications for the Construction of Highways, the Standard Specifications for the Construction of Bridges, and the Standard Specifications for the Construction of Structures, and the contract documents.

DESIGN-NEW STRUCTURES

This bridge is designed for an H-20 load having a design speed of 55 mph. The design speed shall be 55 mph unless otherwise specified. The design speed shall be 55 mph unless otherwise specified.

DESIGN-REHABILITATION AND STRENGTHENING

The bridge is to be rehabilitated and strengthened in accordance with the Standard Specifications for the Rehabilitation and Strengthening of Bridges.

CONCRETE (CAST-IN-PLACE)

Concrete shall be placed in accordance with the Standard Specifications for the Construction of Structures.

SUBSTRUCTURE CONCRETE (CAST-IN-PLACE)

Substructure concrete shall be placed in accordance with the Standard Specifications for the Construction of Structures.

PRESTRESSED CONCRETE SUPERSTRUCTURE

Prestressed concrete shall be placed in accordance with the Standard Specifications for the Construction of Structures.

REINFORCING STEEL BARS

Reinforcing steel bars shall be placed in accordance with the Standard Specifications for the Construction of Structures.

STEEL TOUGHNESS REQUIREMENT

The provisions of the AASHTO Specification in accordance with Article 804.9 of the Standard Specifications shall apply to those areas of structural steel as shown and/or designated by these plans.

PAINTING (NEW STRUCTURES)

Shop and field painting shall be in accordance with Section 805 of the current Standard Specifications for the Construction of Structures.

BRIDGE GUARDRAIL

The guardrail and terminal sections, posts and end sections shall conform to the Standard Specifications for the Construction of Structures.

STEEL GRID FLOORING (CONCRETE FILLED TYPE)

The steel grid flooring shall be installed in accordance with the Standard Specifications for the Construction of Structures.

STEEL GRID FLOORING (OPEN TYPE)

The steel grid flooring shall be installed in accordance with the Standard Specifications for the Construction of Structures.

CLEANING AND PAINTING (EXISTING STRUCTURES)

Cleaning and painting shall be in accordance with the Standard Specifications for the Construction of Structures.

MAINTAINING TRAFFIC

Traffic shall be maintained in accordance with the Standard Specifications for the Construction of Structures.

BRIDGE GUARDRAIL

The guardrail and terminal sections, posts and end sections shall conform to the Standard Specifications for the Construction of Structures.

STRUCTURAL STEEL

Structural steel shall be placed in accordance with the Standard Specifications for the Construction of Structures.

STEEL GRID FLOORING (CONCRETE FILLED TYPE)

The steel grid flooring shall be installed in accordance with the Standard Specifications for the Construction of Structures.

STEEL GRID FLOORING (OPEN TYPE)

The steel grid flooring shall be installed in accordance with the Standard Specifications for the Construction of Structures.

REINFORCING STEEL BARS

Reinforcing steel bars shall be placed in accordance with the Standard Specifications for the Construction of Structures.

STEEL TOUGHNESS REQUIREMENT

The provisions of the AASHTO Specification in accordance with Article 804.9 of the Standard Specifications shall apply to those areas of structural steel as shown and/or designated by these plans.

TABLE NO.	PROJECT NUMBER	COUNTY	SHEET TOTAL
10-VA	5311-8-5-23	01060	2 of 6

NAIL LAMINATED WOOD DECK

The bridge timber or lumber shall be selected for 100% pressure treated No. 2 Medium Grade or better, as specified in the Standard Specifications for the Construction of Structures.

BRIDGE GUARDRAIL

The guardrail and terminal sections, posts and end sections shall conform to the Standard Specifications for the Construction of Structures.

STEEL GRID FLOORING (CONCRETE FILLED TYPE)

The steel grid flooring shall be installed in accordance with the Standard Specifications for the Construction of Structures.

STEEL GRID FLOORING (OPEN TYPE)

The steel grid flooring shall be installed in accordance with the Standard Specifications for the Construction of Structures.

REINFORCING STEEL BARS

Reinforcing steel bars shall be placed in accordance with the Standard Specifications for the Construction of Structures.

STEEL TOUGHNESS REQUIREMENT

The provisions of the AASHTO Specification in accordance with Article 804.9 of the Standard Specifications shall apply to those areas of structural steel as shown and/or designated by these plans.

NOTE	YES	NO
1		
2		
3		
4		
5		
6		
7		
8		
9		
10		
11		
12		
13		
14		
15		
16		
17		
18		
19		
20		

THE WEST VIRGINIA DEPARTMENT OF TRANSPORTATION
DIVISION OF HIGHWAYS-STRUCTURES

REINFORCING STEEL BARS

STEEL TOUGHNESS REQUIREMENT

GENERAL NOTES

1. The provisions of the AASHTO Specification in accordance with Article 804.9 of the Standard Specifications shall apply to those areas of structural steel as shown and/or designated by these plans.

NOTE SELECTION TABLE

NOTE	YES	NO
1		
2		
3		
4		
5		
6		
7		
8		
9		
10		
11		
12		
13		
14		
15		
16		
17		
18		
19		
20		

CONTROL VALUE

CODE	VALUE
1	1000
2	1000
3	1000
4	1000
5	1000
6	1000
7	1000
8	1000
9	1000
10	1000
11	1000
12	1000
13	1000
14	1000
15	1000
16	1000
17	1000
18	1000
19	1000
20	1000

WEST VIRGINIA DEPARTMENT OF TRANSPORTATION
DIVISION OF HIGHWAYS-STRUCTURES
STANDARD BRIDGE PLANS
GENERAL NOTES
STANDARD SHEET BR-2A

PRESTRESSED CONCRETE SUPERSTRUCTURE

The provisions of the AASHTO Specification in accordance with Article 804.9 of the Standard Specifications shall apply to those areas of structural steel as shown and/or designated by these plans.

STEEL TOUGHNESS REQUIREMENT

The provisions of the AASHTO Specification in accordance with Article 804.9 of the Standard Specifications shall apply to those areas of structural steel as shown and/or designated by these plans.

PROJECT NUMBERS		WV	COUNTY	SHEET	OF
FEDERAL	STATE	DISTRICT	GILMER	3	6
S311-8-5-23		SEVEN			

ESTIMATE OF QUANTITIES
PROJECT NO. S311-8-5-23
FOR INFORMATION ONLY

DESCRIPTION	UNIT	QUANTITY	UNIT PRICE	TOTAL
DECK TIMBER	EA	2	11.00	22.00
TIMBER CURB	EA	6	1.00	6.00
TIMBER BLOCKOUT	EA	4	1.00	4.00
NAILS	EA	1	1.00	1.00
CLIPS	EA	1	1.00	1.00
STRINGERS	EA	1	1.00	1.00
WEARING PLATES	EA	1	1.00	1.00
BACKWALL PLATES	EA	1	1.00	1.00
DIAPHRAGM ASSEMBLIES	EA	1	1.00	1.00
BEARING ANCHOR PLATE	EA	1	1.00	1.00
STONE	EA	1	1.00	1.00
GABION BASKET	EA	1	1.00	1.00
GABION STONE	EA	1	1.00	1.00
1/2" X 2" HIGH STRENGTH BOLTS W/NUT	EA	16	1.00	16.00
1/2" X 2" HIGH STRENGTH BOLTS W/WASHER	EA	16	1.00	16.00
4# REBAR	EA	4	1.00	4.00

* - ALL STRUCTURAL STEEL SHALL CONFORM TO THE REQUIREMENTS OF ASTM A572 GRADE 50 AND SHALL BE HOT DIPPED GALVANIZED AND FABRICATED AS SHOWN ON SHEETS 4 AND 5 OF 6. GALVANIZING SHALL CONFORM TO ASTM A123 EXCEPT BOLTS AND NUTS WHICH SHALL CONFORM TO ASTM A153.

SCOPE OF WORK

1. REMOVE EXISTING DECK AND SUPERSTRUCTURE.
2. PLACE AND WELD NEW STRINGERS AND BACKWALL PLATES.
3. PLACE NEW TIMBER DECK.
4. REPAIR SHOULDERS AND APPROACHES.
5. SITE DRESS, SEED, AND MULCH ALL DISTURBED AREAS.

WEST VIRGINIA DEPT. OF TRANSPORTATION		DIVISION OF HIGHWAYS		DISTRICT SEVEN	
SUPERSTRUCTURE REPLACEMENT PLANS OF BEAR FORK W-BEAM ON C.R. 8 (SLS) OVER BEAR FORK GILMER COUNTY					
REVISED DATE BY	1/1	RMW	05-10	06-10	06-10
DESIGNED BY					
CHECKED BY					
DATE					
SCALE					
				SHEET 3 OF 6	
				11-8-23	
				7517.1	

EXISTING ELEVATION AND END VIEW OF
ESTIMATE OF QUANTITIES & SCOPE
OF WORK.

PROJECT NUMBERS	WV COUNTY	SHEET	OF
FEDERAL STATE	DISTRICT	4	6
3311-6-5-23	SEVEN	GILMER	

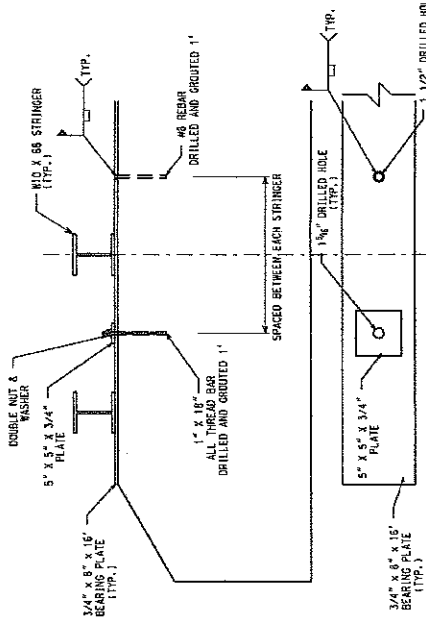
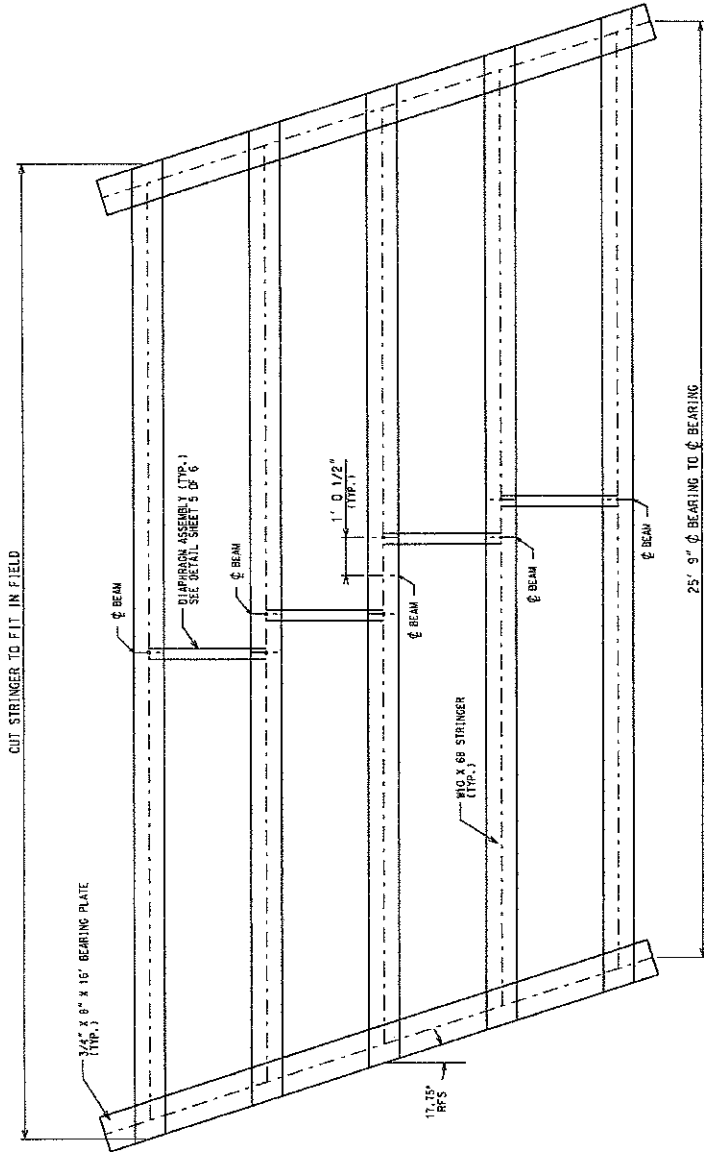

ABUTMENT 1 BEARING
DETAIL
NO SCALE

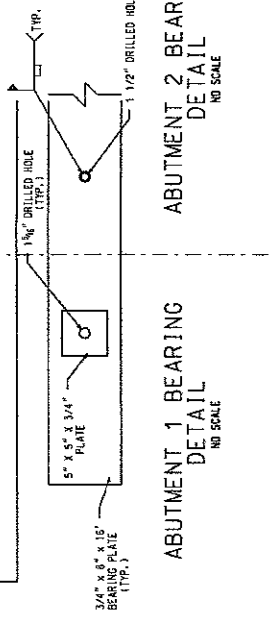

ABUTMENT 2 BEARING
DETAIL
NO SCALE



ABUTMENT BEARING PLATE
DETAIL
NO SCALE

STEEL LAYOUT
NO SCALE

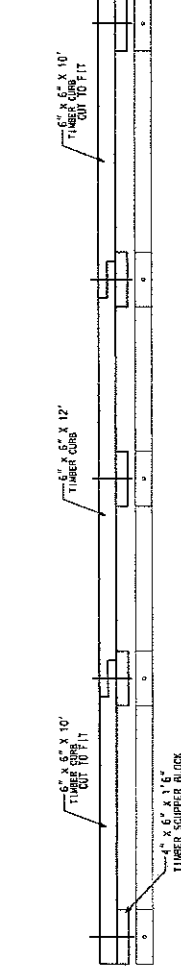

CURB LAYOUT
NO SCALE



CURB SPLICE DETAIL A
NO SCALE

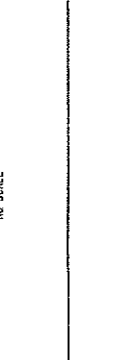

WEST VIRGINIA DEPT. OF TRANSPORTATION DIVISION OF HIGHWAYS DISTRICT SEVEN	
SUPERSTRUCTURE REPLACEMENT PLANS OF BEAR FORK W-BEAM BRIDGE OVER BEAR FORK GILMER COUNTY	
REVISIONS DATE BY	06-10
DESIGNED BY	06-10
DRAWN BY	06-10
CHECKED BY	06-10
APPROVED BY	06-10
BR. NO.	31-6-5-23
SHEET	4 OF 6
STEEL LAYOUT - CURB DETAIL - BEARING DETAIL	
17917.11	

PROJECT NUMBERS	WV	COUNTY	SHEET	OF
FEDERAL	STATE	DISTRICT		
5311-8-5-23	SEVEN	GILMER	5	6

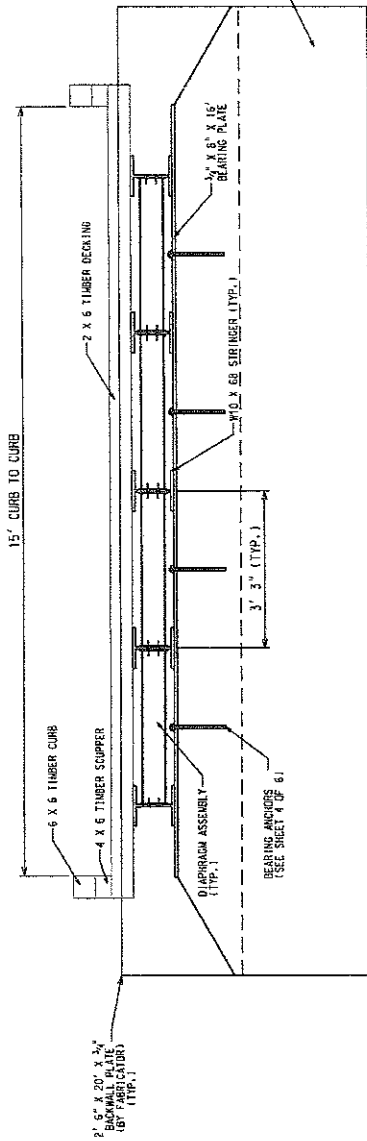

TYPICAL ABUTMENT DETAIL
NO SCALE

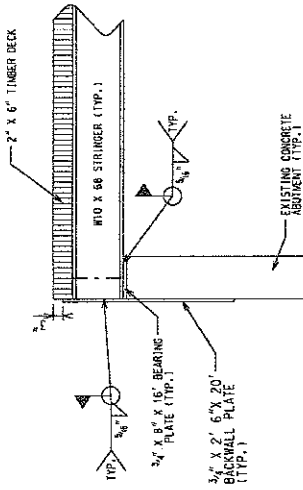

PROFILE WELD DETAIL
NO SCALE

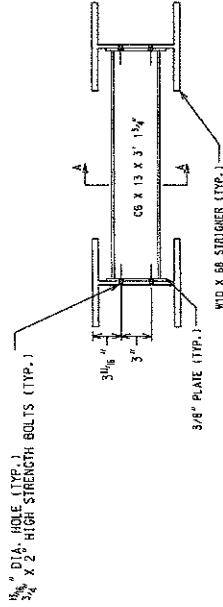

DIAPHRAGM ASSEMBLY DETAIL
NO SCALE

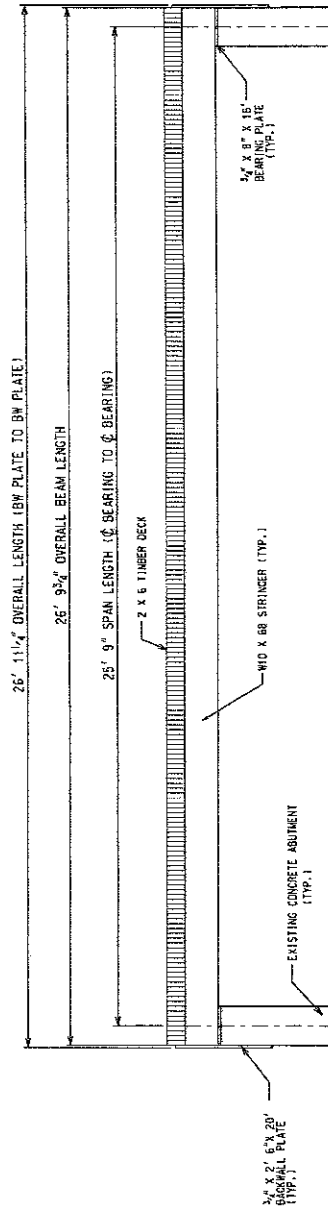

ELEVATION VIEW
NO SCALE

WEST VIRGINIA DEPT. OF TRANSPORTATION	
DIVISION OF HIGHWAYS	
DISTRICT SEVEN	
SUPERSTRUCTURE REPLACEMENT PLANS OF	
BEAR FORK W-BEAM BRIDGE	
OVER BEAR FORK	
GILMER COUNTY	
REVISIONS DATE BY	05-10
DRAWN BY	BKR
CHECKED BY	05-10
DESIGNED BY	06-10
REVIEWED BY	06-10
DATE	06-10

ELEVATION VIEW, ABUT. DETAILS, DIAPHRAGM DETAILS, & WELD DETAILS.	SHEET 5 OF 6
	BP-NO. 11-9-23
	(1917-11)

PROJECT NUMBERS		WV		COUNTY		SHEET	
FEDERAL		STATE		DISTRICT		OF	
S311-8-5-23		SEVEN		GILMER		6	

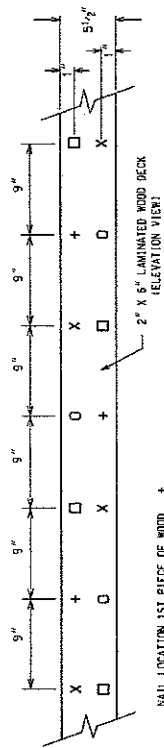

2" X 6" LAMINATED WOOD DECK
ELEVATION VIEW

NOTES: ALL NAILS FOR
BRIDGE DECK SHALL BE
20 PENNY WEIGHT.

NAIL LOCATION 1ST PIECE OF WOOD +
2ND " " " " X
" " " " " " O
" " " " " " O
" " " " " " O
" " " " " " O
" " " " " " O

TIMBER DECK NAILING DIAGRAM
NO SCALE

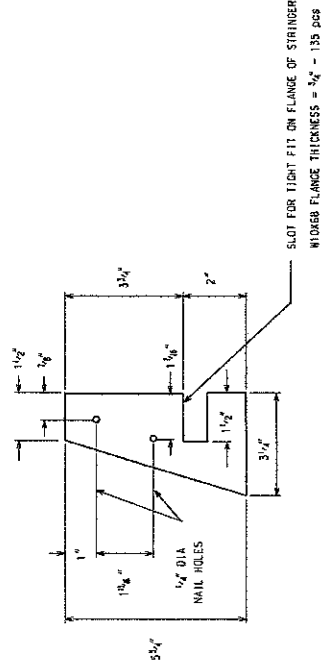

DECK ANCHOR PLATE DETAILS
NO SCALE

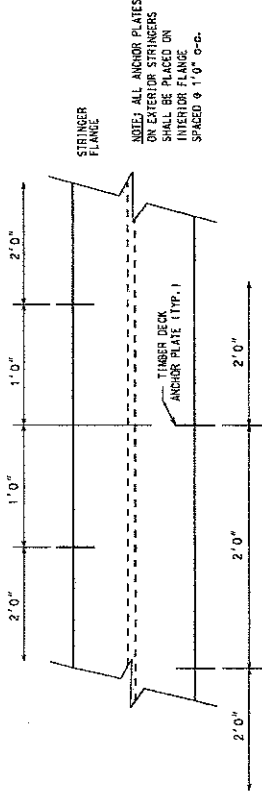

DECK ANCHOR PLATE SPACING DETAIL
(INTERIOR STRINGER)
NO SCALE

WEST VIRGINIA DEPT. OF TRANSPORTATION DIVISION OF HIGHWAYS DISTRICT SEVEN		SUPERSTRUCTURE REPLACEMENT PLANS OF BEAR FORK W-BEAM ON C.R. 8 (SLS) OVER BEAR FORK GILMER COUNTY		SHEET 6 OF 6 BR-ANG-11-8-5-23 (7911.1)	
REVISIONS	DATE BY	DESIGNED BY	DATE BY	CHECKED BY	DATE BY
	03-10	BKR	05-10		
	05-10		05-10		
	05-10		05-10		

VENDOR PREFERENCE CERTIFICATE

Certification and application* is hereby made for Preference in accordance with *West Virginia Code*, §5A-3-37. (Does not apply to construction contracts). *West Virginia Code*, §5A-3-37, provides an opportunity for qualifying vendors to request (at the time of bid) preference for their residency status. Such preference is an evaluation method only and will be applied only to the cost bid in accordance with the *West Virginia Code*. This certificate for application is to be used to request such preference. The Purchasing Division will make the determination of the Resident Vendor Preference, if applicable.

1. **Application is made for 2.5% resident vendor preference for the reason checked:**
 Bidder is an individual resident vendor and has resided continuously in West Virginia for four (4) years immediately preceding the date of this certification; **or,**
 Bidder is a partnership, association or corporation resident vendor and has maintained its headquarters or principal place of business continuously in West Virginia for four (4) years immediately preceding the date of this certification; **or** 80% of the ownership interest of Bidder is held by another individual, partnership, association or corporation resident vendor who has maintained its headquarters or principal place of business continuously in West Virginia for four (4) years immediately preceding the date of this certification; **or,**
 Bidder is a nonresident vendor which has an affiliate or subsidiary which employs a minimum of one hundred state residents and which has maintained its headquarters or principal place of business within West Virginia continuously for the four (4) years immediately preceding the date of this certification; **or,**
2. **Application is made for 2.5% resident vendor preference for the reason checked:**
 Bidder is a resident vendor who certifies that, during the life of the contract, on average at least 75% of the employees working on the project being bid are residents of West Virginia who have resided in the state continuously for the two years immediately preceding submission of this bid; **or,**
3. **Application is made for 2.5% resident vendor preference for the reason checked:**
 Bidder is a nonresident vendor employing a minimum of one hundred state residents or is a nonresident vendor with an affiliate or subsidiary which maintains its headquarters or principal place of business within West Virginia employing a minimum of one hundred state residents who certifies that, during the life of the contract, on average at least 75% of the employees or Bidder's affiliate's or subsidiary's employees are residents of West Virginia who have resided in the state continuously for the two years immediately preceding submission of this bid; **or,**
4. **Application is made for 5% resident vendor preference for the reason checked:**
 Bidder meets either the requirement of both subdivisions (1) and (2) or subdivision (1) and (3) as stated above; **or,**
5. **Application is made for 3.5% resident vendor preference who is a veteran for the reason checked:**
 Bidder is an individual resident vendor who is a veteran of the United States armed forces, the reserves or the National Guard and has resided in West Virginia continuously for the four years immediately preceding the date on which the bid is submitted; **or,**
6. **Application is made for 3.5% resident vendor preference who is a veteran for the reason checked:**
 Bidder is a resident vendor who is a veteran of the United States armed forces, the reserves or the National Guard, if, for purposes of producing or distributing the commodities or completing the project which is the subject of the vendor's bid and continuously over the entire term of the project, on average at least seventy-five percent of the vendor's employees are residents of West Virginia who have resided in the state continuously for the two immediately preceding years.

Bidder understands if the Secretary of Revenue determines that a Bidder receiving preference has failed to continue to meet the requirements for such preference, the Secretary may order the Director of Purchasing to: (a) reject the bid; or (b) assess a penalty against such Bidder in an amount not to exceed 5% of the bid amount and that such penalty will be paid to the contracting agency or deducted from any unpaid balance on the contract or purchase order.

By submission of this certificate, Bidder agrees to disclose any reasonably requested information to the Purchasing Division and authorizes the Department of Revenue to disclose to the Director of Purchasing appropriate information verifying that Bidder has paid the required business taxes, provided that such information does not contain the amounts of taxes paid nor any other information deemed by the Tax Commissioner to be confidential.

Under penalty of law for false swearing (*West Virginia Code*, §61-5-3), Bidder hereby certifies that this certificate is true and accurate in all respects; and that if a contract is issued to Bidder and if anything contained within this certificate changes during the term of the contract, Bidder will notify the Purchasing Division in writing immediately.

Bidder: JAMATT, INC. Signed: *Jenna E. Mattingly*
 Date: 01/29/2011 Title: PRESIDENT

*Check any combination of preference consideration(s) indicated above, which you are entitled to receive.

RFQ No. 07110156

STATE OF WEST VIRGINIA
Purchasing Division

PURCHASING AFFIDAVIT

West Virginia Code §6A-3-10a states: No contract or renewal of any contract may be awarded by the state or any of its political subdivisions to any vendor or prospective vendor when the vendor or prospective vendor or a related party to the vendor or prospective vendor is a debtor and the debt owed is an amount greater than one thousand dollars in the aggregate.

DEFINITIONS:

"Debt" means any assessment, premium, penalty, fine, tax or other amount of money owed to the state or any of its political subdivisions because of a judgment, fine, permit violation, license assessment, defaulted workers' compensation premium, penalty or other assessment presently delinquent or due and required to be paid to the state or any of its political subdivisions, including any interest or additional penalties accrued thereon.

"Debtor" means any individual, corporation, partnership, association, limited liability company or any other form or business association owing a debt to the state or any of its political subdivisions. "Political subdivision" means any county commission; municipality; county board of education; any instrumentality established by a county or municipality; any separate corporation or instrumentality established by one or more counties or municipalities, as permitted by law; or any public body charged by law with the performance of a government function or whose jurisdiction is coextensive with one or more counties or municipalities. "Related party" means a party, whether an individual, corporation, partnership, association, limited liability company or any other form or business association or other entity whatsoever, related to any vendor by blood, marriage, ownership or contract through which the party has a relationship of ownership or other interest with the vendor so that the party will actually or by effect receive or control a portion of the benefit, profit or other consideration from performance of a vendor contract with the party receiving an amount that meets or exceeds five percent of the total contract amount.

EXCEPTION: The prohibition of this section does not apply where a vendor has contested any tax administered pursuant to chapter eleven of this code, workers' compensation premium, permit fee or environmental fee or assessment and the matter has not become final or where the vendor has entered into a payment plan or agreement and the vendor is not in default of any of the provisions of such plan or agreement.

Under penalty of law for false swearing (West Virginia Code §61-5-3), it is hereby certified that the vendor affirms and acknowledges the information in this affidavit and is in compliance with the requirements as stated.

WITNESS THE FOLLOWING SIGNATURE

Vendor's Name: JANATT, INC.

Authorized Signature: Jane S. Mattingly Date: 01/29/2011

State of WEST VIRGINIA

County of Taylor, to-wit:

Taken, subscribed, and sworn to before me this 29 day of JANUARY, 2011.

My Commission expires November 29, 2020

AFFIX SEAL HERE

NOTARY PUBLIC Janeane B Mattingly

